

564

SCIENTIFIC LIBRARY



UNITED STATES PATENT OFFICE

GOVERNMENT PRINTING OFFICE

11-8625



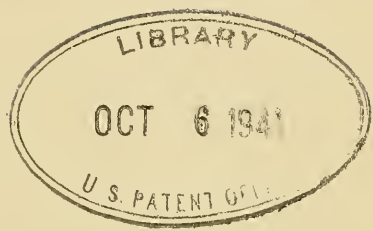

13

13

13

13

13

13

13

9

327508

Pat,

23- 1st 1

THE GARDENER'S MAGAZINE,

AND

REGISTER

OF

RURAL AND DOMESTIC IMPROVEMENT :

COMPRISING

TREATISES ON LANDSCAPE GARDENING,
ARBORICULTURE, FLORICULTURE, HORTICULTURE,
AGRICULTURE, RURAL ARCHITECTURE,
GARDEN STRUCTURES,
PLANS OF GARDENS AND COUNTRY RESIDENCES,
SUBURBAN VILLAS, &c.

ALSO

LISTS OF NEW AND RARE PLANTS, FRUITS AND VEGETABLES.

CONDUCTED BY

J. C. LOUDON, F.L.S. H.S. &c.

AUTHOR OF THE ENCYCLOPÆDIAS OF GARDENING, AGRICULTURE, &c.

VOL. VI.

NEW SERIES.

LONDON :

PRINTED FOR THE CONDUCTOR ;

AND SOLD BY

LONGMAN, BROWN, GREEN, AND LONGMANS,
PATERNOSTER ROW ;

AND A. AND C. BLACK, EDINBURGH.

1840.

~~XXXXXXXXXX~~

S B

403

.G-22

58
4
G-228
V. 6, new Ser.
1840
SCNHAB

P R E F A C E.

THE present volume concludes our Second Series. The Third Series will commence with No. I. on the 1st of January next; and when this Third Series has extended to five volumes, it will be concluded, and a Fourth Series commenced. In short, it is intended, that in future no series shall exceed five volumes; in order that possessors of any odd volumes or numbers of the work may, at a moderate expense, procure all the other volumes or numbers of the series to which what they belong. At the same time, this division of the work into different series will not prevent those who have taken it from the beginning from continuing the regular numeration of their volumes.

With the Third Series will be commenced a superior mode of arranging the contents, and other improvements will also be introduced.

J. C. L.

Weywater, November 15. 1840.

C O N T E N T S.

ORIGINAL COMMUNICATIONS.

	Page	Page
GENERAL SUBJECT.		
<i>Historical and Statistical.</i>		
A Summary View of the Progress of Gardening, and of Rural Improvement generally, in Britain, during the Year 1840; with some Notices relative to the State of both in Foreign countries. By the Conductor	617	
Provincial, Horticultural, Botanical, and Floricultural Societies, &c.	676	
<i>Historical, Critical, and Descriptive.</i>		
Descriptive Notices of Select Suburban Residences, with Remarks on each; intended to illustrate the Principles and Practice of Landscape-Gardening. By the Conductor.		
No. 14. Fortis Green, Muswell Hill, the Villa of W. A. Nesfield, Esq.	49	
No. 15. Kingsbury, the Residence of Thomas Harris, Esq.	233	
Notes on some Country Seats and Gardens in Lincolnshire, Derbyshire, Staffordshire, Warwickshire, Middlesex, Surrey, Kent, and Hertfordshire, from May to October, 1840:		
Harlaxton Manor; The Village of Harlaxton	329	
Hungerton Hall; Belton, near Grantham; Chatsworth; Chatsworth to Wootton Lodge, by Chesterfield and Derby; Wootton Lodge; Alton Towers; Trentham Hall; East Combe, near Blackheath; Woodlands, Blackheath; Charlton House; Belford; Belvidere, near Dartford; West Heath; Harringay House, near Hornsey; Arno's Grove, Southgate; Wood-		
lands; — Park, near Enfield; Beech Hill Park, near Potter's Bar; Leamington; Bradley House; Beech Lawn; The Priory; Danby Cottage; Radford Cottage; Cullis's Nursery; Theobald's, near Waltham Cross; Bayfordbury, near Hertford; Kew Gardens; Wilmot's Gardens, Isleworth; The Horticultural Society's Garden. By the Conductor	569	
The Derby Arboretum, founded by Joseph Strutt, Esq., containing a Catalogue of the Trees and Shrubs, the History and object of its Formation, the Reasons for the main Features of the Plan, and Directions for its future Management:—I. Catalogue of the Trees and Shrubs. II. History and proposed Management; the Object in View, Situation, and Instructions; Reasons for the Main Features of the Plan; Management of the Derby Arboretum. By the Conductor	521	
The Derby Arboretum, and probable Influence of Mr. Strutt's Example; with some Remarks on the Advantages that would result from uniting Horticulture with Botany in Public Gardens. By W.	59	
Notice of Visits by J. B. W.:		
To Eyewood and Presteign	377	
To Wentworth House	185	
To Wortley Hall	105	
Notice of a Visit to Milford Nursery	656	
Notice of the Plants which grow in the open Air in the Borromean Islands (Isola Bella and Isola Madre) in the Lago Maggiore. By Signor Giuseppe Manetti	241	
The Garden Literature of Italy. By Signore Giuseppe Manetti	70	
Observations on the present Appearance and		

Prospects of Gardening in the Canadas. By Alexander Gordon - 63
 On the Orange Groves of Canada -
 On the state of Gardening in North America - 660
 Notes on the Progress of Gardening in the United States during the Year 1840. By A. J. Downing, Esq., Newburgh, near New York - 642
 On the Gardening and Agriculture of Egypt, from Dr. Bowring's Report laid before Parliament - 645
 An Account of the Tea Plantation of Henry Veitch, Esq., in the Island of Madeira. Communicated by Mr. Veitch. - 113
 The Examination of Gardeners in Denmark. By A. Weibach - 108
 On Emigration, with reference to Gardeners, and on the Prospects of Botanical Collectors. By Peritus. Communicated by K. B. D. - 115
 On the Conduct of the Horticultural Society towards George Glenny, Esq., F. H. S. Communicated by Mr. Glenny - 16
 On the Preference for Scotch Gardeners. By J. Wighton, Gardener to the Earl of Stafford, Cossey Hall - 244

Science of Vegetable Culture.

Remarks and Observations suggested by the reading of Dr. Lindley's "Theory of Horticulture:" - Bottom Heat; Temperature and Protection from Frost; Colours of Plants; Moisture of the Soil and Watering; Atmospheric Moisture and Temperature; Ventilation; Germination and Maturation of Seeds; Seed-saving and Packing of Seeds; Growth by the Root; Action of Leaves, Action of Flowers; Propagation by Eyes; Propagation by Leaves; Propagation by Cuttings; Propagation by Layers and Suckers; Budding and Grafting; Pruning; Training; Potting; Transplanting; Preservation of Races by Seed; Improvement of Races; Hybridising and Cross-breeding; Principles of Resting; Soils and Manures. By R. Lymburn - 425
 Facts relative to the Fecundation of Flowers with Pollen which had been kept for some Weeks. By Hay Brown, Gardener, Stoke Edith Park, Herefordshire - 597
 On the Means of supplying Atmospheric Moisture to Hot-houses, including some Observations on the Use of Steam for that Purpose. By John Rogers, Jun., Esq., F. R. S. H. S., &c. - 281
 On moistening the Air in Hot-houses. By T. Appleby, Gardener to T. Brocklehurst, Esq. - 189
 Some Account of a Mode of warming and ventilating Hot-houses, invented and applied by John Penn, Esq., Engineer, &c., at his Residence at Lewisham, in Kent. By the Conductor - 120
 Mr. Wilmot's Opinion of Mr. Penn's Mode of heating and ventilating Hot-houses - 128
 Opinion of Mr. Penn's Mode of Heating, &c. By N. M. T. - 640
 On the Management of Conical Boilers, with some Observations on the comparative Strength and Economy of different Kinds of Fuel. By John Rogers, Jun., F.R.S. F.H.S. - 196
 On the Utility of Draining; with some Methods adapted for various Soils. By John Fish - 246
 On pulverising Soils as a Means of improving them. By John Fish - 383
 On Jauffret's Manure, Quénard's Manure, Clarke's desiccated Compost, Lance's Compost, &c. By the Hon. and Rev. W. Herbert, D.C.L., F.H.S., &c. - 290
 On the Causes of Canker in Fruit Trees. By John Jennings - 389

Destruction of Insects in Gardens.

On destroying Insects on Cacti. By M. Sello - 657

An effectual Mode of destroying the *Aphis lanigera*, or Woolly Blight, on Apple Trees. By N. T. - 110
 A Mode of destroying the White Bug in Hot-houses. By W. Anderson, F.L.S., Curator of the Chelsea Botanic Garden - 110
 A Method of preventing the Attacks of the Asparagus Fly. By M. Kerll. - 111

Garden Structures and Instruments.

Description of a Forcing-Pit, heated by hot Water. By John Rogers, Jun. - 139
 On the Conical Boiler for heating Hot-houses by hot Water. By D. Beaton - 129
 Description of the Conical Boiler and hot-water Apparatus invented by John Rogers, Jun., Esq., F.R.S. Communicated by Mr. Rogers - 132
 Description of a Glass Case for growing Plants in Rooms. By Sir John Robinson, Sec. F.S.E. - 117
 Notice of an Espalier Rail put up in Cossey Hall Gardens. By J. Wighton, Gardener there - 254
 Notice of an Improvement made in the Mode of fixing Mr. Booth's Wire Trellis for Espaliers. Communicated by W. B. Booth, F.H.S. - 16
 Description of the Hypsometer, an Instrument invented by John Sang, Esq., Land Surveyor, for taking the Heights of Trees, Buildings, and other Objects. Communicated by Mr. Sang, Land Surveyor, Kirkcaldy - 190
 Description of an Instrument used for taking the Heights of Trees. By H. W. Jukes, Esq. - 384

LANDSCAPE-GARDENING.

On propagating, and preserving through the Winter, tender Plants adapted for being turned out into Flower Gardens during Summer. By N. M. T. - 186
 Some Thoughts on the Effect of Shadows in Garden Scenery. By R. W. F. - 243
 On certain prevailing Errors in laying out and managing Flower Gardens. By Alexander Forsyth - 255

ARBORICULTURE.

Report on the new Species and Varieties of Hardy Trees and Shrubs raised in the Horticultural Society's Gardens since the last Report, made in October, 1838, and published in the *Gardener's Magazine*, vol. xiv. p. 581. Drawn up for the *Gardener's Magazine* by Mr. Gordon, Foreman of the Arboretum, by Permission of the Council of the Horticultural Society - 1. 631
 List of Part of the Trées and Shrubs furnished for the Arboretum of Joseph Strutt, Esq., at Derby, by Messrs. Whitley and Osborn, with their Ready-Money Prices. With Introductory Remarks by the Conductor - 73
 Notice of the Reception, by Nurserymen, of a Proposal to name Trees and Shrubs in their Collections; with an Examination of a "Popular Catalogue of Trees and Shrubs," published by Mr. Rivers, Jun. By the Conductor - 10
 Description of a Transplanting Machine invented by James Kidd, Gardener to Lord Kinnaird, Rossie Priory Gardens, Perthshire. By J. Kidd. - 252
 On the singular Origin of the Purple Laburnum, and on the New Field which it opens to the Horticulturist for the Production of Hybrid Plants. By the Hon. and Rev. W. Herbert, D.C.L., F.H.S., &c. - 289
 Postscript to Mr. Herbert's Article on *Cytisus Adami* in p. 289. By the Hon. and Rev. W. Herbert, D.C.L., F.H.S., &c. - 380
 Further Remarks on the *Cytisus Adami*. By the Hon. and Rev. W. Herbert, D.C.L., F.H.S. &c. - 381

On the Decay in growing Larch and Spruce Fir Trees. By J. Wighton - 385
 On the *Torreya taxifolia*, a new coniferous Tree of Florida. By A. J. Downing - 658

FLORICULTURE.

Botanical, Floricultural, and Arboricultural Notices of the Kinds of Plants newly introduced into British Gardens and Plantations, or which have been originated in them; together with additional Information respecting Plants (whether old or new) already in Cultivation; the whole intended to serve as a perpetual Supplement to the *Encyclopædia of Plants*, the *Hortus Britannicus*, the *Hortus Lignosus*, and the *Arboretum et Fruticetum Britannicum*, 18. 144. 201. 292. 343. 545. 592
 On Conservative Walls, and their Superiority, as Sources of Botanical and Floricultural Interest, to Green-houses and Conservatories. By the Rev. T. Bainbridge, M. A. - 23
 On raising Seeds received from the Swan River Colony. By J. Brewster, Gardener to Mrs. Wray, Oakfield Lodge, Cheltenham - 258
 On the Treatment of Cape Iridææ. By W. 257
 On a new Method of introducing Palms of large Size into Hot-houses. By Dr. John Lhotsky, F.H.S., of Bavaria, &c. - 596
 On grafting the *Acacia*. By John Brewster, Gardener to Mrs. Wray - 388
 Notes on *Cereus senilis* and some other Mexican Plants. In a Letter from Mr. Tate of the Botanic Garden, Sloane Street, to Mr. Beaton. Communicated by Mr. Beaton - 26
 Notice of a Plant of *Cereus grandiflorus*, at Eatington Park, Shipston on Stour. By W. Hutchinson, Gardener to E. J. Shirley, Esq., M.P. - 389
 Remarks on flowering the *Renanthera cocinea*. By J. Webster - 203
 On the Culture of the *Chrysanthemum*. By John Thackeray - 154
 Notice respecting some new hybrid Primroses raised between the Polyanthus and the Chinese Primrose. By James Seymour, Kitchen-Gardener to the Countess of Bridgewater, at Ashridge - 88
 On the Cultivation of the Carnation at Forres Nurseries. By John Grigor - 153
 Practical Observations on the Cultivation of the Hyacinth in Haarlem - 27
 A Year's Culture of the Hyacinth, as prac-

tised at Haarlem in Holland, beginning with the Season for Planting, in October - 81
 Observations on forcing Hyacinths - 31
 Observations on the Rotz, a Disease in Hyacinth Bulbs - 150
 On Hyacinths, the Flowers of which appear expanded in Water. By A. B. - 152

HORTICULTURE.

On the Shriveling of Grapes. By W. H. - 598
 On retaining the Tendril of the Grape Vine. By R. T. - 89
 On Melons. By Alexander Forsyth - 204
 On the Cultivation of the Alpine Strawberry in Pots. By James Seymour, Gardener to the Countess of Bridgewater, at Ashridge - 89
 On the Culture of the Chicory as a Winter Salad. By James Cuthill - 90
 On the Culture of Seymour's Superb White Celery. By J. Seymour - 91
 On sowing the Early Scarlet Horn Carrot as a main Crop; and on storing it in Winter. By James Seymour, Gardener at Ashridge Park - 207
 Some Remarks on the Culture of the White Carrot. By W. Masters, F.H.S., &c., of the Exotic Nursery, Canterbury - 209
 On the Turkey Onion. By James Alexander, late Gardener at Maeslough Castle - 207
 On the Jerusalem Artichoke. By Alexander Forsyth - 259
 On the Wild Potato (*Solanum tuberosum*). Translated from Pöppig's *Reise in Chile und Peru*, for the *Gardener's Magazine*, by J. L. - 259
 Some Account of a Method of growing and preserving New Potatoes for a Winter Supply. By Amaziah Saul - 390
 On the Culture and Preservation of Potatoes. By Robert Lymburn, Secretary to the Kilmarnock Horticultural Society - 210

BEE CULTURE.

On Apiarian Societies. By J. Wighton, Gardener to Lord Stafford, Cossey Hall, near Norwich - 591
 On Honey. By J. Wighton - 593

AGRICULTURE.

On Wire Field Gates. By George Buist - 193

REVIEWS.

Dr. Lindley's Theory of Horticulture - 155
 Organic Chemistry in its application to Agriculture and Physiology. By Justus Liebig, M.D. Ph.D. F.R.S., &c. - 604
 Vegetable Organography; or an Analytical Description of the Organs of Plants. By M. A. P. DeCandolle - 163
 Transactions of the Horticultural Society of London - 346. 394. 467
 On the growth of a peculiar Fir resembling the *Pinaster*, 394. *Clianthus puniceus*, 395. Experiments on the Cultivation of the Potato, 395. Causes of the Diseases and Deformities of the Leaves of the Peach Tree, 395. *Averrhoa carambota*, 397. *Chlidanthus fragrans*, 398. Causes of the premature Death of Part of the Moorpark Apricot, and some other Wall Fruit Trees, 398. On forcing Peaches and Nectarines, 399. On the Power possessed by Plants of absorbing coloured Infusions by their Roots, 401. On the Means employed in raising a Tree of the *Impératrice* Nectarine, 401. On the Cultivation of French Pears in Scotland, and on the Foundation and Management of Fruit Borders, 402. New Varieties of Fruit raised from Seed by T. A. Knight, Esq., 408. On Two Species of Insects found injurious to the Pear Tree, 408. Remarkable Va-

rieties of Fruits sent since 1831, 410. Supposed absorbent Powers of the Cellular Points, or Spongioles, of the Roots of Trees, and other Plants, 412. *Bignonia venusta*, 413. *Alströmérias*, 413. Means of destroying the Red Spider in the Melon Frame, 414. Experiments made in 1836 relative to the Cultivation of Potatoes, 415. On the Cultivation of the Melon in open Frames, 467. Cultivation of Figs, 468. Cultivation of the Cinnamon in England, 468. Six new Varieties of Vine recently introduced from Dukhum (Deccan), 468. Culture of the Strawberry, 469. *Cattleya guttata*, 470. Preservation of the early Foliage of Peach and Nectarine Trees, 470. New Method of destroying Insects in Stoves and Green-houses, 471. Economical Use of Melon Frames, 471. Propagation of Trees by Cuttings in Summer, 473. Cultivation of *Chlidanthus fragrans*, 474. Half-hardy species of *Salvia* called *Salvia patens*, 474. Effects produced on Plants by the Frost which occurred in England in the Winter of 1837-8, 475.
 A Pocket Dictionary, comprising the Names, History, and Culture of all Plants known in Britain; with a full Explanation of technical Terms. By Joseph Paxton, F.L.S.,

H.S., &c., assisted by Professor Lindley, Ph.D., F.R.S., &c.	557
Instructions in Gardening, for Ladies. By Mrs. Loudon	350
Every Lady her own Flower-gardener. By Louisa Johnson	660
The Floricultural Magazine and Miscellany of Botany. Edited by Robert Marnock	603
The Florist's Journal	602
Icones Plantarum rariorum Horti Regii Botanici Berolinensis. Figures and Descriptions of rare Plants in the Royal Botanic Garden at Berlin. By H. F. Link, Fr. Klotzsch, and Fr. Otto	556
Icones Plantarum; or, Figures, with brief descriptive Characters and Remarks, of new or rare Plants selected from the Author's Herbarium. By Sir William Jackson Hooker, K.H., LL.D., &c.	167
Traité de la Composition et de l'Ornement des Jardins, &c.	658
Design for laying out the Inner Circle of the Regent's Park as a Garden for the Royal Botanic Society of London	605
The Eastern Arboretum, or Rural Register of all the remarkable Trees, Seats, Gardens, &c., in the county of Norfolk. By James Grigor	352
The Eastern Arboretum, or Rural Register of all the remarkable Trees, Seats, Gardens, &c., in the County of Norfolk:—Trees and Gardens of Norwich, continued; Cossey Park; Dereham and its Neighbourhood. By James Grigor	600. 661
William May's Priced Catalogue of select Plants grown in the Hope Nursery, Looming Lane, Bedale, Yorkshire	605
Traité des Végétaux qui composent l'Agriculture, Horticulture, &c.	659
The Flora of Yorkshire. By Henry Baines	660
A History of British Ferns. By Edward Newman, F.L.S.	168
Annales des Sciences Physiques et Naturelles, d'Agriculture et d'Industrie, publiées par la Société Royale d'Agriculture de Lyon	553
A Flora of North America; containing abridged Descriptions of all the known indigenous and naturalised Plants growing North of Mexico; arranged according to the Natural System. By John Torrey and Asa Gray	558
Illustrations of the Botany and other Branches of the Natural History of the Himalayan Mountains, and of the Flora of Cashmere. By J. Forbes Royle, M.D., F.R.S., &c. &c.	348
Icones selectæ Plantarum quas in Prodomo Systematis universalis, ex Herbariis Parisiensibus præsertim ex Lessertiano descripsit Aug. Pyr. DeCandolle. Editæ a Benj. De Lessert	350
Exposition des Fleurs et d'autres Produits, &c. à Lyon	659
Monographie du Genre Camellia, &c. By the Abbé Berleze, 2d Edit.	664
The Surveyor, Engineer, and Architect; or London Monthly Journal of the Physical and Practical Sciences. By a Committee of Practical Surveyors, Engineers, and Architects	171
Illustrations of Indian Architecture. By M. Kittoe	356
Ricauti's Rustic Architecture. Parts I. and II.	355
History and Guide for drawing the Acanthus, and every other Description of Ornamental Foliage, by Rule. By J. Page, Ornamental Draftsman	355
A Treatise on Agriculture and Dairy Husbandry. By James Jackson	665
The Journal of the English Agricultural Society	169
Hints for the Use of Highland Tenants and Cottagers. By a Proprietor	214
Religion and Crime; or the Distresses of the People, and the Remedies. By John Minter Morgan	606

CATALOGUE.

Catalogue of Works on Gardening, Agriculture, Botany, rural Architecture, &c., lately published, with some Account of those considered the more interesting:—	32. 92. 216. 262. 296. 559
The Elements of Botany for Families and Schools	32
Verhandlungen der K.K. Landwirthschafts-Gesellschaft in Wien, &c.	298
Kollar's Treatise on Insects injurious to Gardeners, Foresters, and Farmers	92
Annual Flower Seeds, Fruit Trees, Seeds and Implements, and a List of Geraniums, sold by E. Sang and Sons	93
Johnson on increasing the Depth of Soils	216
Mrs. Loudon's Ladies' Flower-Garden of Ornamental Annuals	262
Mrs. Loudon's Ladies' Flower-Garden of Ornamental Bulbous Plants	263
Buist's American Flower-Garden Directory, &c. &c.	297
Appleby's Catalogue of Plants	217
Rivers's Rose Amateur's Guide, &c.	298
Sayers's Treatise on the Culture of the Dahlia and Cactus	559
Bridgeman's Florist's Guide	560
Rivers's descriptive Catalogue of Fruits	263
Rivers's descriptive Catalogue of Pears	263
Fruit Trees, by a practical Observer	263
Clark's Method of pruning and training Standard Apple Trees	263
Lindley's Appendix to the First Twenty-three Volumes of Edwards's Botanical Register	94
Torrey and Gray's Flora of North America	94
Webb's Otia Hispanica, seu Delectus Plantarum rariorum aut nondum rite notarum per Hispanias sponte nascentium	94
Mörch's Catalogus Plantarum Horti Botanici Hafniensis	34
Lemaire's Cactearum Genera nova Speciesque novæ, et omnium in Horto Monvilliano cultarum ex Affinitatibus naturalibus Ordinato nova Indexque Methodicus	32
Visiano's Della Origine ed Anzianità dell'Orto Botanico di Padova, &c.	297
Webb's Otia Hispanica, &c.	297
Burnett's Plantæ utiliores	297
Descrizione dei Funghi Mangerecci più comuni dell' Italia, e de' Velenosi che possono eo' medesimi confondersi, &c.	298
Francis's Grammar of Botany	560
Macgillivray's Manual of Botany	560
Agardh's Recensio Specierum Gen. Pteridis	33
Sheer's Kew and its Gardens	297
Brady's Visitor's Guide to Knole, in the County of Kent	35
Sproule's Treatise on Agriculture, adapted to the Soil and Climate of Ireland	34
Sir Humphry Davy's Elements of Agricultural Chemistry	95
Baydon's Art of valuing Rents and Tillages. By John Donaldson	94
Hodges's Use and Advantages of Pearson's Draining Plough	35
Transactions of the Society of Arts, Manufactures, and Commerce	298
The Sixth Annual Report of the Royal Cornwall Polytechnic Society	95
Daly's Revue générale d'Architecture et des Travaux Publics, &c.	85
London Architectural Precedents	267
Davy's Architectural Precedents	562
Ricauti's Rustic Architecture	561
Lewis's Illustrations and Description of Kilpeck Church, Herefordshire	561
Perkins's Improved Patent Apparatus for warming and ventilating Buildings	266
Parke's Report on A. M. Perkins's Patent Steam Boiler	299
Jones's Principles and Practice of Leveling	267
The Year-Book of Facts in Science and Art	267
Redfield's Remarks on Mr. Espy's Theory of Centripetal Storms, &c.	35

Drummond's Letter to Thomas Phillips, Esq. R.A., on the Connexion between the Fine Arts and Religion, and the Means of their Revival	- 551
Mallet's first Report upon Experiments upon the Action of Sea and River Water, &c.	- 34
Walker's Gatherings from Grave-Yards, particularly those of London	- 95
The British Almanack of the Society for the Diffusion of Useful Knowledge for the Year 1840	- 35
The Companion to the Almanack; or Year-Book of general Information for 1840	- 36
Twenty Years' Experience in Australia, &c.	299
Tims's Literary World	- 266
Taylor's Help to the Schoolmistress	- 562

LITERARY NOTICES.

The Gardener's Annual Register	- 607
Mrs. Loudon's Magazine of Gardening	- 607
Mrs. Loudon's Gardening for Ladies	- 267
Mrs. Loudon's Companion to the Ladies' Flower-Garden	- 267

MISCELLANEOUS INTELLIGENCE.

GENERAL NOTICES.

General Subject — *Historical*. The Penny Post, as a Gardening Measure, 96; Seeds received from Friends, A. G., 220; Seeds sent by Post, 268; Botanical and Horticultural Works, Amicus, 268; The most curious Gardens in Europe, especially in Britain, about the Year 1730, 223; Nurserymen's Catalogues, 97; The late Mr. Roscoe originally a Gardener, 219; The skilled Gardener, 669; Rural Enjoyment, 218; Clegg and Samuda's Atmospheric Railway, 564.

Scientific. Soil and Vegetation supplied by Nature with Sea Salt, Thomas C. Brown, 217; Influence of various Circumstances in the Growth of Plants in modifying their Physiological Action, 417; Excrementitious Exudations of the Roots of Plants, R. Lyburn, 218; Aiding the Germination of Seeds by Quicklime, R. Lyburn, 218; Preservation of Grain or Seeds, 669; Mudie's Views of the Adaptations of Nature in the Vegetable Kingdom, J. M., 220; New or concentrated Manures, John Spencer, 358; Effect of Light which has passed through coloured Glass on Plants, J. B. W., 301; The Effect of Light passing through coloured Glass on Plants, John Spencer, 419; Experiments with a Liquid obtained from Bones, R. Glendinning, 607; Supplying packed Plants with Water during long Voyages, 609; Burning Gas for warming Rooms or Greenhouses, 220; Temperature, 300; Temperature of Plants, 418; To destroy Worms, A Subscriber, 37; Sunk Waterholders, Samuel Taylor, 302; Calcareous Concretions on the Bottoms of Steam Boilers, &c., 97; Wooden Pavement for Streets, 564; Radiation from Trees, 97.

Landscape-Gardening and Garden-Architecture. — Glazing with Lead instead of Putty, Amicus, 299; Pocock's Patent Flexible Asphaltic Roofing, 269; The Triumphal Arch, 303; Ironwork coated with Gas Liqueur, Tar, or Pitch, P. S., 514; A Layer of Bitumen, a Preventative of the Ascent of Moisture in Walls, 564; Approach Roads, 564; Ornamental Pottery, 269; Caithness Flagstone, 97; Taste, 223; Welterstedt's patent Metal, 37; Preservation of Wood, 358; Preserving Wood, 302; Dry Rot, 609.

Arboriculture. — The Oak, 219; The Mistletoe, 219; Quercus Cerris, 219; A new Cedar, W. H. W., 419; Raising Coniferous Plants from Seed, 303; The Genus Faccinium, S. M., 303; Grafting the Lilac on the Ash, J. Scott, 37; Use of Lime in planting Trees, 37.

Floriculture. — *Clerodendron squamatum Vahl* and *Hort. Brit.*, speciosissimum *Paxt.*, D.

Traité de la Composition et de l'Ornement des Jardins	- 563
Paul's Catalogue of Roses	- 562
Drummond and Sons' Catalogue of Implements, Seeds, Plants, &c. for 1840	- 562
Drysdale and Lawson's Catalogue of Seeds, &c.	- 562
Carter's Catalogue of Dutch and Cape Flower Bulbs, for 1840	562
Catalogue des Plantes du Jardin de M. De Kwitka, situé à Osnowa aux Environs de Kharcow	- 563
Chevreul's De la Loi du Contraste simultané des Couleurs, &c.	- 563
Johnson and Shaw's Farmer's Almanac and Calendar, for 1841.	607
Lhotsky's Journey from Sydney to the Australian Alps	- 217
Audouin's Histoire des Insectes nuisibles à la Vigne, et particulièrement de la Pyrale, &c.	- 563
Report of the Society for obtaining free Admission to the National Monuments	- 563
Notice Biographique sur J. B. Huzard	- 563
Bibliothèque Huzard	- 563

Beaton, 268; Imported Orange Trees, G. M. Elliot, 268; Citrus nobilis, W. Brown, 224; The Leaves of Orange Trees, 224; *Beaumontia grandiflora*, D. Beaton, 419; *Musa superba Rox.*, 608; Preserving Dahlia Roots, T. Taylor, 224; New Fuchsias, 609; *Sálvia patens*, John Duncan, 224; *A'rabis purpurea*, 224.

Horticulture. — The Pommeral Pine-apple, W. Gordon, 609; The Swainston Seedling Strawberry, 609; Myatt's Pine Strawberry, 302; The Peach and the Nectarine the same species, T. C. Brown, 36; Superiority of Mr. Hoare's System of Pruning the Vine, T. C. Brown, 36; Mushrooms growing in the same Soil with Truffles, 420.

Agriculture. — Farms, 564; A Hand-Plough for stirring the Soil between Carrots, 302; New Kinds of Wheat, John Clarke, 38; The Rohan Potato, 98; *Màdia sativa*, W. T., 38; The Bokhara Clover, 666; *Sida Abutilon L.*, W. T., 38.

Domestic Economy. — Steele's improved Kitchen-Range, 513; Three new improved Kitchen-Ranges, W. Wilds, 39; Kirkwood's Stove, William Kirkwood, 39; White's Patent Stoves, J. M'Nab, 40; A Carriage Talking-Tube, 41; A Device for serving the Bees of any Hive with Food when they need it, J. D., 36; Pumpkin Sugar, 670.

Education. — Bury St. Edmunds Botanical Library, H. T., 43; The Hampstead public Library, 223; Cheap circulating Libraries, 222; Degradation, as an Element of Punishment, 41.

FOREIGN NOTICES.

ITALY.

Garden of Baron Zanoli, Giuseppe Manetti, 98; Villa Mallerio at Gernetto, 304; Villa Silva at Cinisello, 305; Communications from Monza, 304; Villa Litta, at Lainate, 306; the Garden of Cavaliere Dr. Luigi Sacco in Milan, 306; Imperial and Royal Villa, 225; Commercial Horticulturists in Milan, G. Manetti, 225; Root-grafting, Giuseppe Manetti, 309; *Pópulus fastigiata* at Pavia, 224; Milan, Brera, 225.

GREECE.

The Grecian Cottage of the present Day, 303; A Classical Lease, 226; A Group of Grecian Plants, 303; Mode of felling Trees in Greece, 225; The Corn-Drage of Greece, 226.

RUSSIA.

Gardening at Cronstadt, B. C., 41; Gardening in Moscow, 565; New *Ribes*, F. E. Wagner, 99.

MADEIRA.

Cinnamon and Tea Plantations, Henry Veitch, 358.

INDIA.

The Improvement of the Agriculture and Horticulture of India, 42.

NORTH AMERICA.

Great Price for a Plant of *Madura multicaulis*, 226; The largest Purple Beech and Cedar of Lebanon, Alexander Gordon, 565; Architecture and Gardening, 565; The Mascall Plant, J. M., 226.

AUSTRALIA.

Gardening at Sydney, John Thompson, 42.

DOMESTIC NOTICES.

ENGLAND.

General Subject.—Effects of the Winter of 1837–8, 667; Opening Public Gardens and Museums to all the Public, 361; Curtailing the alleged Species of Herbaceous Plants, 668; Gardener's Benevolent Association, 269; Prison Gardening, 44; The Chester Nursery, T. B., 44; The Horticultural Fête at Chiswick, May, 310, June, 360; The South London Horticultural Society's Show, 361; An Addition to the Regent's Park, 566; An additional Park in London, 565; Kew Gardens, 566; Public Park at Liverpool, 566; The Leeds Zoological and Botanical Gardens, 566; Gardening in the Neighbourhood of Liverpool, W. H., 269; Wreath of Flowers formed from dried Specimens, 101; Artificial Flowers and whole Plants made of Feathers, W. A. M., 312.

Landscape-Gardening.—Mr. Nichols of Blunderstone, as a Landscape-Gardener, T. Fenn, 44; Improvements at Bedgebury Park, Kent, T. B., 311; Enville, the Seat of the Earl of Stamford, in Worcestershire, L. P., 514.

Implements and Machines.—A new Hedge-Pruner, James Wright, 312; Mr. Read's Hydraulic Machines, J. R., 361.

Arboriculture.—Specimens of Trees and Shrubs received from the Sawbridgeworth Nursery, 100; Mr. Knight's Catalogue of Coniferae, 311; Trees and Shrubs in Croome Park, W. Clarke, 45; Cedar of Lebanon, its Varieties, J. B. W., 172; *Acer crêticum*, W. Clarke, 45; *Acer lobeli*, W. Clarke, 44; English Elms, 44; *Quercus pedunculata*, 668; A transplanted Mulberry Tree, which remained a Year dormant, T. Rutger, 566; Folding Swine among Oaks, Scott Portland, 101.

Floriculture.—*Rhododendron arboreum hybridum*, B. B. Billington, 269; *Wistaria sinensis*, W. Pamplin, jun., 311; The Caper, 46; Roses in November, 45; *Yucca gloriosa*, 101; *Rhodanthe Manglessii*, 45; *Victoria regia Lindl.*, 566; New Annuals raised in the Clapton Nursery, H. L., 45; Works on the Cacti, 311; *Rhizomorpha subterranea*, 173.

Horticulture.—A Fine-Fruit Company, 312; Berries of Black Hamburg Grapes, T. C., jun., 101; The Vine at Valentines, J. J., 311; A new Variety of Peach, 312; The Crop of Apples in Berkshire, 672.

Agriculture.—Pearson's Draining Plough, C. M. B., 102; The Knepp Castle Kidney Potato, 101; *Cannabis sativa* var. *gigantea*, W. P. Taunton, 609; The Bokhara Clover, 46; The Bokhara Clover, Samuel Taylor, 567; The Bokhara Clover, T. Taylor, 101; *Heracleum asperillum*, Bernard Saunders, 45; Naked Barley, or Barley-Wheat, Charles Aldermann, Kenbury, 312; The Rot in Sheep, J. D. C. Sowerby, 313.

Education.—State of Knowledge of the Middle Classes, in a Village in Suffolk, J., 174.

SCOTLAND.

Improvements at the Earl of Stair's, Wigtonshire, 567; Improvements at Thirlestaine Castle,

East Lothian, 567; The Ligneous Flora of the Shetland Islands, 102; Queen Mary's Tree, 362; A Weeping common Oak, Patrick Robertson, 567; *Gladiolus cardinalis*, 567; *Melilotus*, or Bokhara Clover, Archibald Gorrie, 610; Irrigating Meadows with Liquid Manure, 270; Sub-soil Ploughing, 102; Cottage Windows, 270.

IRELAND.

Belfast Botanical Society, 363; The Belfast Botanic Garden, 567; National Education in Ireland, 567.

RETROSPECTIVE CRITICISM.

Erratum, 272; Mr. Main's Theory of Vegetable Development, R. Lymburn, 325; Mr. Main's Theory of Vegetable Development, J. Main, 518; Moistening the Air of Hot-houses by Steam, John Lyons, 373; Constitutional Changes in Plants by being grown in Climates not natural to them, D. Beaton, 326; Anomalous Productions of Hybrids, Surreyensis, 568; The Construction of Mr. Penn's Hot-houses, 375; Bartram's Botanic Garden, J. M., 180; New Plants raised in the Birmingham Botanic Garden, David Cameron, 102; Disadvantage of a Gardener boarding with the House Servants of a Family, W. B., 180; Mr. Penn's Mode of Ventilating, &c., D. Beaton, 229; Remarks on Mr. Penn's Mode of Warming and Ventilating, J. R., 272; Mr. Penn's Mode of Warming and Ventilating, Benjamin Fowler, 323; On Mr. Penn's Method of Ventilation, and Mr. Rogers's Conical Boilers, William Anderson, 273; The Advantage of placing Hot-water Pipes higher than the Boiler, J. R., 322; Mr. Rogers's Boiler, and Mr. Beaton's Remarks, W., 227; The Conical Boiler of Mr. Rogers, W., 519; Proportion of Hot-Water Pipe required for heating, Alexander Forsyth, 103; The Grand Conservatory at Chatsworth, Alexander Forsyth, 103; The Grand Conservatory at Chatsworth, 180; The Conservatory at Chatsworth, Alexander Forsyth, 229; The Grand Conservatory at Chatsworth, Amicus, 275; Joyce's Stove, D. Beaton, 276; Glazing with Lead Lath instead of Putty, Veritas, 424; Sir John Robison's Plant Case, Sir John Robison, 230; The Plates to Prince Puckler Muskau's Hints on Landscape-Gardening, John Adey Repton, 615; An Attempt to build in Lincoln's Inn Fields, J. Main, 518; Paring the Verges of Walks, Alexander Forsyth, 103; Ricauti's Rustic Architecture, reviewed, S. J. Ricauti, 519; Large Trees, 181; *Pinus Pinsapo* and *P. cephalonica*, D. B., 277; *Pinsapo*, Vilmorin, 568; *Pöpuslus græca*, J. Mease, 231; *Ulmus fulva*, J. Mease, 231; Native Scotch Pine, R. Lymburn, 104; Mr. Rivers's Roses, 47; Grafting the Orange on the Pomegranate, J. M., 180; Inaccuracies in the Names of Fruit Trees, &c., E. B., 278; The Black Eagle Cherry, J. B. W., 520; The Elton and Black Eagle Cherries, T. R., 375; The Van Mons Leon Leclerc Pear, L. Leclerc, 616; Mr. Lymburn on the Culture and Preservation of the Potato, J. Main, 278; Mr. Lymburn on the Potato, D. B., 277; Storing Carrots for Winter Use, John Pearson, 47; Mr. Gorrie's Horsehoe, 48; Naked Barley, 672; Yellow Clover and Black Nonsuch, 278; The Calling of the Queen Bee, W. Dunbar, 181; Habits of the Jackdaw, John Wighton, 275; Braithwaite's Kitchen-Range, G. M. Braithwaite, 321.

Mr. Main's Remarks on a Review of some of his Works which appeared in the "Athenæum," 517.

Regulations for the internal Administration of the Garden of the Hort. Soc. of London, 318.

The Royal Botanic Garden at Kew, 183. 232. 590.

Botanical Garden (Kew). Copy of the Report made to the Committee appointed by the Lords of the Treasury in January, 1838, 365.

The West London Gardeners' Association for mutual Instruction, 175. 177. 313. 371. 420. 611.

The Royal Botanic Society of London, Inner Circle, Regent's Park, 514.
The Competition Designs for laying out the Gardens of the Royal Botanic Society of London, in the Inner Circle, Regent's Park, 321.
Royal Caledonian Horticultural Society, P. N. 174.
Caledonian Horticultural Society, 270.

QUERIES AND ANSWERS.

Alton Towers, 280; Syon House Gardens, James Allen, 48; Winter Garden of Petersburg, Surreyensis, 280; The Plant Naras, J. B. W., 327; Names of Insects, J. O. W., 104; the Coccus on the Larch, F., 326; Adaptiveness of Trees and Shrubs to Soils, E., 326; The Curl in the Leaves of Vines, a Subscriber, 568; The Cause of the Curl in the Leaves of Vines, 674; Moorpark Apricot, W. Brown, 376; Stock for the Moorpark Apricot, J. W. D., 280; A new

System of cultivating Frame Potatoes, T. R., 376; Yellow Dutch Turnip, N. T., 104; Roughhead's Swedish Turnip, D. R., 48; A clothly Substance, white above and greenish beneath, L. R., 375; M. J. Berkeley, 376.

BIOGRAPHY.

Mr. Smith of Monkwood, Ayrshire, 46; Contributions towards a Life of Lancelot Brown, Esq., the celebrated Landscape-Gardener, and Thos. Whately, Esq., the Author of *Observations on Modern Gardening*, 327; Biographical Memoirs of Charles Aug. Skellin, Superintendent of the Royal Gardens of the Kingdom of Bavaria, 674.

OBITUARY.

Death of Baron Jacquin, 104; Allan Cunningham, 48.

LIST OF ENGRAVINGS.

No.	DIAGRAMS.	Page
35—57.	Details of Wire Field Gates	194—196
53.	Illustrative of the Mode of naming Plants at the Derby Arboretum	523
61—68.	Sections of Sash-Bars	572—578
62.	Sections of Glass, showing the difference in thickness	572
70.	Lines showing a Mode of arranging Walks on a Lawn	587
71.	Section of Ground, showing a Sunk Fence	589
72.	Beds intended for Flowers in the Royal Botanic Garden, Regent's Park	606
73.	Beds proposed for Flowers in the Royal Botanic Garden, Regent's Park	606
INSTRUMENTS, IMPLEMENTS, UTENSILS, AND MACHINES.		
5—7.	Views and Section of Kirkwood's Stove	39, 40
14—51.	A Brick Tally in use at the Derby Arboretum	74—521
15—18.	Details of a Glass Case for growing Plants in Rooms	117—119
23—28.	Views and Plans of Rogers's Conical Boiler and Hot-Water Apparatus	133—136
31—34.	Sang's Hypsometer	191, 192
38.	Chimney to Rogers's Conical Boiler	197
42.	Trough for supplying Atmospheric Moisture to Hot-houses	284
43.	Section of Perkins's Double Boiler	325
45.	Read's Barrow Engine	361
47, 48.	Details of an Instrument for taking the Heights of Trees	384, 385
PLANTS.		
40.	<i>Laurus nobilis</i>	242
44.	<i>Cynodon Dactylon</i>	349
46.	Queen Mary's Thorn	362
49.	<i>Pinus Pinaster Lemoniana</i>	394
73, 74.	<i>Torreya taxifolia</i>	659

No.	GARDEN STRUCTURES.	Page
1—3.	Details of a Wire Trellis, erected at Carclew	16—18
19—22.	Plans and Sections of Hot-houses, illustrative of Mr. Penn's Mode of Warming and Ventilating	122—127
29, 30.	Plan and Section of a Forcing Pit, heated by Hot-water	140, 141
41.	Section of a Hot-house illustrative of Mr. Penn's Mode of Warming and Ventilating	272
63—66.	Elevation, Plan, and Sections of a Conservative Wall at Chatsworth	573, 574
67.	Section of a Hot-house, showing a Mode of covering with a Thatched Roof	578
69.	Section of a Bonnet-roofed Plant-house	579
PLANS OF GARDENS AND COUNTRY RESIDENCES.		
4.	Plan of House and Gardens, showing the site of a Conservative Wall	25
18—10.	Plan of the Grounds at Fortis Green, the Villa of W. A. Nesfield, Esq.	50—52
12.	Ground Plan of the House and Gardens at Fortis Green	55
52.	Plan of the Derby Arboretum	522
55.	Plan, Sections, and Elevations of the Ground at the Derby Arboretum	536
VIEWS OF BUILDINGS AND GARDEN SCENERY.		
11.	View from the Lawn Front of Fortis Green	53
13.	Entrance Front of Fortis Green	56
39.	View of Isola Bella	241
54.	One of the Pavilions at the Derby Arboretum	535
56.	Design for a Statue and Stone Seats for the Derby Arboretum	537
57—60.	Views of the Lodges and Entrances to the Derby Arboretum	538—541

LIST OF NEW AND RARE PLANTS

FIGURED IN THE BOTANICAL PERIODICALS FOR THE YEAR 1840.

<i>Ranunculaceæ.</i>	
AQUILEGIA	
brachyceras	☞ □ North of Europe - 546
fragrans	☞ □ Himalayas - 546
glauca	☞ □ Himalayas - 546
CLEMATIS	
lathyridolia	☞ Δ - - - - 19

<i>Pitiosporicææ</i>	
SO'LLYA	
linearis	☞ □ Swan River - 145
<i>Malvaceæ.</i>	
ABUTILON	
striatum	☞ □ Brazil - 19

X LIST OF NEW AND RARE PLANTS FIGURED IN 1840.

HIBISCUS	multifidus	☞ □	Swan River	- 343	GESNERIA	cochlearis	✱ ⊠	Organ Mountains	- 202
NUTTALLIA	malvaeflora	⊠ ⊠	Texas	- 201		mollis	☞ ⊠	Caraccas	- 548
<i>Balsamineæ.</i>					<i>Gesneriæcæ.</i>				
IMPATIENS	glandulifera	⊠	Nepal	- 293	SINNINGIA	Youngiana	⊠	hybrid	- 294
	macrochila	⊠	India	- 145	<i>Ericæcæ.</i>				
	picta	☉ ?	East Indies	- 19	ERICA	Macnabiana	☞ □	hybrid	- 548
	tricornis	⊠	India	- 145	<i>Epacrtiæcæ.</i>				
<i>Rutæcæ.</i>					CYSTANTHE				
CORREA	Harrisii	☞ □	hybrid	- 293	sprengeloides		☞ □	Van Diemen's	- 594
	longiflora	☞ □	hybrid	- 593	Land				
LEMONIA	spectabilis	☞ □	Cuba	- 593	<i>Apocynæcæ.</i>				
<i>Rhamnæcæ.</i>					MANDEVILLA				
CEANOTHUS	pallidus	☞ -	-	- 293	suavolens		⊠	Buenos Ayres	- 147
<i>Leguminosæ.</i>					<i>Asclepiadæcæ.</i>				
ACACIA	dentifera	☞ □	Swan River	- 547	GONOLOBUS	hispidus	☞ ⊠	Brazil	- 202
CYCLOGYNE	canescens	☞ □	Swan River	- 593	<i>Bignoniæcæ.</i>				
DILLWYNIA	speciosa	☞ □	? New South Wales	- 201	BIGNONIA	Twediiana	⊠	Buenos Ayres	- 549
HARDENBERGIA	digitata	⊠	Swan River	- 593	<i>Cobææcæ.</i>				
LUPINUS	Barkèriæ	☞ □	Mexico	- 19	COBÆA	macrostema	⊠	Guayaquil	- 147
	leptocarpus	⊠	Mexico	- 546	<i>Polemoniæcæ.</i>				
PHYSOLEPIDIUM	carinatum	⊠	King George's Sound	- 547	PHLOX	Coldryana	☞ □	hybrid	- 594
<i>Onagræcæ.</i>					<i>Convolvulæcæ.</i>				
LOPEZIA	lineata	☞ □	Mexico	- 457	BATATAS	betacea	✱ ⊠	Demerara	- 594
<i>Melastomæcæ.</i>					IPOMOEA				
LASIANDRA	petiolata	☞ □	? Brazil	- 19	Learii		⊠	Ceylon	- 147
<i>Philadelphæcæ.</i>					longifolia		⊠	Mexico	- 295
DEUTZIA	corymbosa	☞ □	Nepal	- 146	<i>Boraginæcæ.</i>				
<i>Passifloræcæ.</i>					CYNOGLOSSUM				
PASSIFLORA	Mooreana	⊠	Buenos Ayres	- 146	longiflorum		☞ ⊠	Cashmere	- 549
	verrucifera	⊠	? Brazil	- 547	<i>Solanæcæ.</i>				
<i>Portulacæcæ.</i>					FABIANA				
PORTULACA	Thellusonii	⊠	South of Europe	- 343	imbricata		☞ □	Chili	- 21
<i>Cactiæcæ.</i>					SOLANUM				
CEREUS	latifrons	☞ □	South America	- 548	angustifolium		☞ □	Buenos Ayres	- 594
	leucanthus	☞ □	Chili	- 202	uncinellum		☉ ✱	-	- 202
	Martianus	☞ □	Mexico	- 19	<i>Scrophulariæcæ.</i>				
	multiplex	☞ □	South Brazil	- 293	SALVIA	linarioides	☞ □	? South America	- 295
<i>Rubiæcæ.</i>					VERBA SCUM				
BOUVARDIA	angustifolia	☞ □	Mexico	- 343	tauricum		⊠	? hybrid	- 295
	splendens	☞ □	? Mexico	- 146	<i>Labiatæcæ.</i>				
<i>Dipsacæcæ.</i>					ORTHOStYPHON				
MORINA	longifolia	☞ ⊠	India	- 344	incurvus		☞ ⊠	Sylhet	- 344
<i>Compôsilaæcæ.</i>					<i>Verbenæcæ.</i>				
CENTAUREA	pulchra	⊠	Cashmere	- 294	VERBENA		ameana	☞ □	? Mexico
DAHLIA	glabrata	⊠	Mexico	- 294	<i>Acanthæcæ.</i>				
ECHINACEA	dubia	✱ ⊠	Mexico	- 146	GOLDFUSSIA	glomerata	☞ □	Sylhet	- 148
HYMENOXYS	californica	⊠	California	- 594	PHLOGACANTHUS	curviflorus	☞ □	Sylhet	- 202
LIASTRIS	propinqua	☞ ⊠	North America	- 594	THUNBERGIA	aurantiaca	⊠	C. G. H.	- 147
STEVIA	breviaristata	⊠	South America	- 294	<i>Begoniæcæ.</i>				
<i>Lobeliæcæ.</i>					BEGONIA				
LOBELIA	igneæ	☞ ⊠	Mexico	- 20	Barkeri		☞ □	Mexico	- 148
<i>Orchidæcæ.</i>					<i>Scitaminæcæ.</i>				
					CURCUMA				
					Roscoæana		☞ ⊠	East Indies	- 149
					<i>Iridiæcæ.</i>				
					GELASINE				
					azurea		☞ □	South America	- 149
					PATERSONIA				
					sapphirina		☞ □	Swan River	- 22
					RIGIDELLA				
					flammea		☞ □	Mexico	- 203
					<i>Orchidæcæ.</i>				
					AGANISIA				
					pulchella		☞ ⊠	Demerara	- 344

BRASAVO'LA					
glauca	£	☒	Mexico	-	- 550
venosa	£	☒	Honduras	-	- 550
CAMARO'TIS					
purpurea	£	☒	East Indies	-	- 203
CATASE'TUM					
integerrimum	£	☒	Guatemala	-	- 550
Russellianum	£	☒	Guatemala	-	- 148
CATTLE'YA					
Aclandæ	£	☒	Brazil	-	- 551
CYNO'CHUS					
maculata	£	☒	La Guayra	-	- 149
CYMBI'DIUM					
pendulum	£	☐	Nepal	-	- 295
CYRTOCHI'LUM					
mystacinum	£	☒	Peru	-	- 21
DENDRO'Bium					
Cambridgeanum	£	☒	Khoseea	-	- 149
Devonianum	£	☒	Khoseea	-	- 551
EPIDE'NDRUM					
cephiforme	£	☒	Mexico	-	- 21
densiflorum	£	☒	Mexico	-	- 295
glumaceum	£	☒	Brazil	-	- 148
Parkinsonianum	£	☒	Mexico	-	- 148
vitellinum	£	☒	Mexico	-	- 344
GALEA'NDRA					
Baferi	£	☒	Guiana	-	- 552
GRAMMATOPHY'LLEUM					
multiflorum	£	☒	Manilla	-	- 21
LE'LIA					
cinnabarina	£	☒	Rio Janeiro	-	- 595
rubescens	£	☒	-	-	- 551
MAXILLA'RIA					
cucullata	£	☒	America	-	- 148
MILTO'NIA					
candida	£	☒	Brazil	-	- 21
MONACHA'NTHUS					
longifolius	£	☒	Mexico	-	- 550
roseo-âlbis	£	☐	Brazil	-	- 296
MYA'NTHUS					
spindus	£	☒	Brazil	-	- 344
ONCI'OIDIUM					
Batemanianum	£	☒	Mexico	-	- 148
Huntianum	£	☒	Brazil	-	- 344
jachyphyllum	£	☒	Mexico	-	- 550
ODONTOGLO'SSUM					
maculatum	£	☐	Mexico	-	- 296
RODRIGUE'ZIA					
crispa	£	☒	Brazil	-	- 552
SACCOLA'BIUM					
denticulatum	£	☒	Khoseea	-	- 552
SATY'RIMUM					
pustulatum	♣	☐	Cape of Good Hope.	-	- 203
ZYGOPETALUM					
africanum	£	☒	Sierra Leone	-	- 550
<i>Amaryllidææ.</i>					
CALOSTE'MMA					
carneum	♠	☒	Australia	-	- 345
PENTLA'NDIA					
miniata	♠	☒	Peru	-	- 23
SPREKE'LLIA					
cybister var. brevis	♠	☒	S. Amer.	-	- 346
STENOME'SSON					
latifolium	♠	☒	Lima	-	- 346
<i>Asphodelææ.</i>					
THYSANO'TUS					
intricatus	♣	☐	Swan River	-	- 23
<i>Bromeliææ.</i>					
ÆCHME'A					
suavoelens	♣	☐	Brazil	-	- 150
<i>Commelineæ.</i>					
SPIRONE'MA					
fragrans	♣	☒	Mexico	-	- 553
TRADESACA'NTIA					
spicata	♣	☒	Mexico	-	- 23
tumida	♣	☒	Mexico	-	- 553

LIST OF PLANTS

MENTIONED OR TREATED OF IN THE PRESENT VOLUME.

The word “cult.” occurring after any species or variety indicates that there is an article on its culture.

A List of new Species and Varieties of Hardy Trees and Shrubs, raised in the Horticultural Society's Gardens in 1839 - page 1—10	
In 1840 - - - - - 631—640	
List of Part of the Trees and Shrubs in the Derby Arboretum - - - - - 75—80	
List of Plants in the Garden of Baron Zanoli 98	
List of Plants in the Borromean Islands 241—243	
List of Ericas arranged in Sections, with a view to Propagation - - - - - 316	
<i>A'bies</i> álba - - - - - 568	
canadensis - - - - - 306. 659	
cephalónica (now <i>Picea</i> cephalónica) - 304. 656	
Douglàsii - - - - - 656	
excelsa - - - - - 581	
<i>Clanbrasiliana</i>	
stricta - - - - - 304	
foliis variegatis - 304	
monströsa - - - - - 304	
pygmaea - - - - - 304	
tenuifolia - - - - - 304	
Menziësi - - - - - 656	
Smithiana - - - - - 656	
<i>Abutilon</i> striatum - - - - - 19	
vitifolia - - - - - 546	
<i>Acacia</i> affinis - - - - - 338	
cyclops - - - - - 338	
dentifera - - - - - 547	
diffusa - - - - - 338	
hastulata - - - - - 271	
pendula - - - - - 15	
pulchella - - - - - 338	
saligna - - - - - 547	
<i>Acanthophippium</i> bicolor - 310	

List of Plants geographically arranged, with Observations upon the Effects produced on them by the Frost, which occurred in England, in the Winter of 1837-8 - 483—502	
Catalogue of Trees and Shrubs in the Derby Arboretum - - - - - 523—532	
List of Plants growing against a Conservative Wall at Chatsworth - - - - - 574—577	
<i>A'canthus</i> mollis - - - - - 344	
<i>A'cer</i> crëticum - - - - - 45	
heterophyllum - - - - - 45	
Lobëlii - - - - - 44	
obtusatum - - - - - 44	
platanoides - - - - - 44	
Pseudo-Plátanus striatum - - - - - 601	
ovatum - - - - - 44	
<i>Aconitum</i> ovatum - - - - - 546	
<i>Actæ'a</i> spicata - - - - - 664	
<i>Adenocarpus</i> Boissieri - 94	
<i>Æchmæa</i> Mertensis - - - - - 150	
suavoelens - - - - - 150	
<i>Aërides</i> odoratum 310. 360.	
514	
<i>Æ'sculus</i> Hippocastanum - 354	
<i>Aganisia</i> pulchella - - - - - 344	
<i>Agapanthus</i> umbellatus - 582	
<i>Agaricus</i> campestris - - - - - 271	
<i>Allamãnda</i> cathartica - - - - - 236	
verticillata - - - - - 306	
<i>Allium</i> azurëum - - - - - 553	
Cæpa sterilis - - - - - 663	
carulëscens - - - - - 553	
cæruleum - - - - - 553	
<i>A'lnus</i> jorullensis - - - - - 295	
<i>A'loe</i> plicatilis - - - - - 681	
<i>Alströmëria</i> <i>Pelegrina</i> - 413	
álba - - - - - 413	
acutifolia - - - - - 413	
edulis - - - - - 413	
Hookëri - - - - - 413	
Ligtu - - - - - 413	
pallida - - - - - 413	
psittacina - - - - - 413	
pulchella - - - - - 413	
<i>Altingia</i> (<i>Araucaria</i>) excelsa 506	
<i>Amaltea</i> acrisincola - - - - - 306	
<i>Amaryllis</i> formosissima - 345	
<i>solandraeflora</i> - - - - - 150	
<i>Amygðalus</i> glandulosa - - - - - 167	
orientalis - - - - - 305	
<i>Anagallis</i> alternifolia - - - - - 549	
cærulea - - - - - 303	
<i>Andropogon</i> Cálamus aro-	
maticus - - - - - 349	
<i>Angræ'cum</i> bilobum - - - - - 552	
<i>Anöna</i> <i>Cherimölia</i> - - - - - 652	
<i>Anthëricum</i> reflexum - - - - - 23	
<i>Anthoxánthum</i> odoratum - 670	

<i>A'porum indivisum</i> - 552	<i>Brom. An. rotunda</i> - 306	<i>Cean. pallidus</i> - 293
<i>leonis</i> - 552	<i>rùbra</i> - 306	<i>papillosus</i> - 167
<i>Aquilegia brachyceras</i> - 546	<i>Broughtonia aurea</i> - 293	<i>thyrsiflorus</i> - 293
<i>fragrans</i> - 546	<i>Bröwnca grändiceps</i> - 237	<i>Cedrea odorata</i> - 652
<i>glauca</i> - 546	<i>Brugnansia sanguinea</i> - 689	<i>Cedrus Deodara</i> - 481
<i>pubiflora</i> - 546	<i>Brunsfelsta undulata</i> - 420	<i>Libani</i> - 173, 565
<i>A'rabis hispida</i> - 664	<i>Brunsvigia Josephinae</i> - 475	<i>Centauria pulchra</i> - 294
<i>purpurea</i> - 224	<i>Burlingtonia candida</i> - 360	<i>Cerasus Laurocerasus</i> 418, 482
<i>A'rachis hypogaea</i> - 309	<i>Calamus Rölång</i> - 306	<i>Cerasus grandiflorus cult.</i> 389, 597
<i>Arãlia japonica</i> - 657	<i>Calanthe discolor</i> - 595	<i>latifrons</i> - 548
<i>Araucaria Dombeyi</i> - 481	<i>Calceolaria arachnoidea</i> - 555	<i>leucanthus</i> - 202, 294
<i>imbricata</i> - 306, 588	<i>pinuata</i> - 555	<i>Martianus</i> - 20
<i>A'rbutus americana</i> - 605	<i>plantagina</i> - 555	<i>múltiplex</i> - 293
<i>Andrachne</i> - 45	<i>rugosa</i> - 555	<i>oxypetalus</i> - 548
<i>laurifolia</i> - 20	<i>Calluna vulgaris</i> - 102	<i>senilis</i> - 26
<i>U'nedo</i> - 600	<i>Calostemma carneum</i> - 345	<i>speciosissimum</i> - 310
<i>Arctostaphylos alpina</i> - 112	<i>Camardis purpurea</i> - 293	<i>Ceroxylon andicola</i> - 482
<i>nitida</i> - 294	<i>Camellia japonica</i> 158, 270, 306, 307	<i>Chamaerops humilis</i> - 481, 482
<i>U'va ursi</i> - 102, 605	<i>admirabile</i> - 307	<i>Cheilanthes formosa</i> - 102
<i>Ardisia elegans</i> - 689	<i>alba plena</i> - 307	<i>Cheiranthus annuus</i> - 99
<i>paniculata</i> - 237	<i>althæaflora</i> - 307	<i>Cheirostemon platanoides</i> 27
<i>Artemisia granatensis</i> - 94	<i>anemoneflora</i> - 307	<i>Chelone centranthifolia</i> - 394
<i>Asclepias tuberosa</i> - 65	<i>anulata</i> - 307	<i>Chenopodium Quinda</i> - 301
<i>Asterotrichon sidoides</i> - 557	<i>Chandlerii</i> - 611	<i>Chionanthus virginicus</i> - 181
<i>Atraphaxis spinosa</i> - 657	<i>Colvilli</i> - 611	<i>Chlidanthus fragrans</i> - 398, 474
<i>A'triplex Halmi</i> - 476	<i>conchiflora</i> - 307	<i>Chrysanthemum leucanthemum</i> - 554
<i>Attalia funifera</i> - 596	<i>coronata</i> - 307	<i>sinense</i> - 272
<i>Averrhoa Carambola</i> - 397	<i>Donklæri</i> - 235	<i>Chrysophyllum Cainito</i> - 652
<i>Azalea hybrida</i> - 271	<i>Elena</i> - 307	<i>Chysis braetescens</i> - 552
<i>indica</i> - 310	<i>Fanny</i> - 307	<i>laevis</i> - 552
<i>indica alba</i> - 271	<i>fasciculata</i> - 307	<i>Cineraria lanata</i> - 594
<i>laterflia</i> - 310	<i>finbriata</i> - 235	<i>Cirrhopetalum auratum</i> - 551
<i>variegata</i> - 310	<i>Gray's Invincible</i> - 235	<i>picturatum</i> - 551
<i>pænicica</i> - 271	<i>imbricata</i> - 235	<i>vaginatum</i> - 595
<i>procumbens</i> - 102	<i>alba</i> - 235	<i>Cistus Fumana</i> - 303
<i>sinensis</i> - 511	<i>King</i> - 235	<i>Citrus madariensis</i> - 306
<i>Bambusa arundinacea</i> - 652	<i>Lady Hume</i> - 235	<i>nobilis</i> - 224, 306
<i>Banksia Lambertii</i> - 306	<i>Maria Elisabetta</i> - 307	<i>sinensis</i> - 306
<i>latifolia</i> - 306	<i>minima</i> - 307	<i>Cleisostoma latifolium</i> - 552
<i>speciosa</i> - 654	<i>odorata Hyacintii</i> - 307	<i>maculosum</i> - 296
<i>Barringtonia speciosa</i> - 237	<i>violacea tubiflora</i> - 307	<i>Clématis angustifolia</i> - 19
<i>Bartsia alpina</i> - 664	<i>paradisica</i> - 307	<i>cirrhuosa</i> - 220
<i>Balatas betacea</i> - 20, 594	<i>pæonicæflora</i> - 611	<i>lathyriifolia</i> - 19
<i>edulis</i> - 594	<i>alba</i> - 235	<i>Sieboldtii</i> - 361
<i>Beaumontia grandiflora</i> - 236, 419	<i>Raniæsi</i> - 307	<i>Cleome lutea</i> - 546
<i>Begonia Barkeri</i> - 148	<i>rùbra maxima</i> - 307	<i>Clerodendron hastatum</i> - 237
<i>macrophylla</i> - 102	<i>simplex</i> - 307	<i>paniculatum</i> - 268
<i>Mejeri</i> - 148	<i>Tirzi</i> - 307	<i>phlomoides</i> - 237
<i>punctata</i> - 557	<i>tricolor</i> - 235	<i>speciosissimum</i> - 268
<i>Benthàmia fragifera</i> - 240, 347	<i>triumphans</i> - 235	<i>squamulata</i> - 268
<i>Berberis Aquifolium</i> - 11	<i>variegata</i> - 611	<i>Clèthra arborea</i> - 294, 305
<i>arctica</i> - 605	<i>plena</i> - 307	<i>mexicana</i> - 294
<i>fascicularis</i> - 11	<i>venosa</i> - 307	<i>Clianthus puniceus</i> 104, 395, 689
<i>ovalis</i> - 605	<i>Woodsi</i> - 235	<i>Clitantes humilis</i> - 22
<i>Bétula alba</i> - 102, 667	<i>Candollea Cunninghamii</i> - 168	<i>lutea</i> - 22
<i>péndula</i> - 667	<i>Cannabis sativa, var. gigantea</i> - 609	<i>Macleanica</i> - 22
<i>Bhojpáttra</i> - 595	<i>Cárica Papaya</i> - 652	<i>Cobea acuminata</i> - 147
<i>papyracea</i> - 595	<i>Carya olivæformis</i> - 225	<i>lutea</i> - 147
<i>Bigonia equinoctialis</i> - 549	<i>Caryopteris mongolica</i> - 99	<i>macrostema</i> - 147
<i>Tweediana</i> - 549	<i>Caryota Onites</i> - 206	<i>scandens</i> - 147, 295
<i>venusta</i> - 236, 413, 689	<i>urens</i> - 306	<i>stipularis</i> - 294
<i>Billardiæra fusiformis</i> - 145	<i>Castanea vesca</i> - 307	<i>Coccoloba emarginata</i> - 306
<i>Bixa Orsellana</i> - 652	<i>Catasetum barbatum</i> - 22	<i>pubescens</i> - 306
<i>Blètia secunda</i> - 551	<i>callosum</i> - 595	<i>Cocos nucifera</i> - 596
<i>Tankervillea</i> - 689	<i>cernuum</i> - 22	<i>Cœlogyne Cummingii</i> - 595
<i>Bolbophyllum limbatum</i> - 595	<i>cornutum</i> - 595	<i>elata</i> - 21
<i>Boronia serrulata</i> - 237	<i>deltoidæum</i> - 551	<i>ocellata</i> - 21
<i>Bouvardia angustifolia</i> - 243	<i>integerrimum</i> - 550	<i>trinervis</i> - 595
<i>splendens</i> - 146, 548	<i>purpurascens</i> - 550	<i>Coffea arabica</i> - 652
<i>triphylla</i> - 146, 343, 548	<i>viridiflorum</i> - 550	<i>occidentalis</i> - 374
<i>Brachycome iberidifolia</i> - 548	<i>longifolium</i> - 22, 550	<i>Collinsia bicolor</i> - 394
<i>Brasavola glauca</i> - 345, 550	<i>proboscideum</i> - 22	<i>grandiflora</i> - 584
<i>nodosa</i> - 203	<i>ruseo-album</i> - 550	<i>Combrum purpureum</i> - 235
<i>venosa</i> - 203, 550	<i>Russellianum</i> - 148	<i>Comparètia rosea</i> - 595
<i>Brassia Lanceana viridiflora</i> - 295	<i>saccatum</i> - 595	<i>Conanthera Echeandia</i> - 376
<i>verrucosa</i> - 295	<i>spinosum</i> - 550	<i>Conferva rivularis</i> - 23
<i>Bromelia Andras</i> - 306	<i>tridentatum var. floribundum</i> - 595	<i>Convòlvulus Batatas</i> - 306
<i>antlqua</i> - 306	<i>trulla</i> - 595	<i>scoparius</i> - 657
<i>barbadensis</i> - 306	<i>Cattleya Aclandiae</i> - 551	<i>Cornus grandis</i> - 294
<i>coccinea</i> - 306	<i>guttata</i> - 470	<i>suecica</i> - 664
<i>jamaicensis</i> - 306	<i>labiata atrosanguinea</i> - 295	<i>Corrae a Harrisii</i> - 293
<i>malabárica</i> - 306	<i>Móssiæ</i> - 310, 595	<i>longiflora</i> - 593
<i>Mertensis</i> - 150	<i>Ceanothus azureus</i> - 167, 293	<i>pulchella</i> - 293, 593
<i>Montserrat</i> - 306	<i>ovatus</i> - 293	<i>speciosa</i> - 293, 593, 689
<i>Providenza</i> - 306		<i>Coryanthes macrantha</i> 310, 345
		<i>maculata</i> - 345

Cor. speciosa var. álba	- 345	Drímys Wínterí	- 590	Fúchsia multiflóra	- 609
(orydalis flávula	- 19	Drósera rotundifólia	- 313	péndula terminalis	- 609
Cosmèlia rúbra	- 689	Dryas octopétala	- 664	Standfíshí	- 679
Cotonáster rotundifólia	- 293	Echeandía terniflóra	- 23	stylósa conspicua	- 609
denticuláta	- 293	Echeverría secundá	- 593	Fumária capreoláta	- 303
Cratægus æstivális	- 559	Echinácea dúbia	- 146	Galeándra Baúeri	- 552
arboréscens	- 559	heterophýlla	- 146	Gardoquia multiflóra	- 21
berberifólia	- 559	Echinocáctus cornígera	- 26	Gárrya elliptica	- 240
Crús-gállí	- 354, 559	leucánthus	- 202	laurifólia	- 295
Douglásii	- 559	múltiplex	- 293	Gaulthéria Shállon	- 589
flabelláta	- 559	Staplesiæ	- 27	Geissómèria longifólia	- 608
gláucia	- 11	Edwárdsia chilénsis	- 672	Gelasine azúrea	- 149
Lambérti	- 605	microphýlla	- 672	grandiflóra	- 150
lineáris	- 559	Elæagnus argénteá	- 45	núda	- 150
mexicána	- 605	Elæís guineénsis	- 596	punctáta	- 150
obcordáta	- 605	E'mpetrum nígrum	- 102	purruclucána	- 150
ovalifólia	- 559	E'pácris campanuláta álba	- 271	texána	- 150
Oxyacantha	- 102	impresá	- 271	Genísta bracteoláta	- 293
péndula regnæ	- 363	variábilis	- 270	Gentiána vérna	- 604
prunifólia	- 559	Epidéndrum amphiglóttis	- 270	gléida	- 147
punctáta	- 354	Trinitátis	- 552	Gesnéria cochleáris	- 202
rivuláris	- 559	bractéscens	- 551	móllis	- 548
sanguinea	- 559	cepifórme	- 21	Gigantina conférta	- 297
unilaterális	- 559	cochleátum	- 552	gaditána	- 297
Cre mastostémón capénsis	- 556	densiflórum	- 295, 552	Gíla tricolor	- 394
Cunninghámia sinénsis	- 481	falcatum	- 203	Gladiolus cardinális	- 567
Cupressó lusitánica	- 419, 656	floribúndum	- 552	communis	- 303
sempervirens stricta	- 656	frágrans	- 21, 148	Gleditschia micracantha	- 100
torulosa	- 586, 653	glumáceum	- 148	sinénsis	- 100
Curcúma lóna	- 652	incumbens	- 345	triacanthos	- 437
Roscoeána	- 149	invérsum	- 21	Gloxínia cauléscens	- 194
Cáscuta europæa	- 555	lancifólium	- 552	speciosa	- 147, 294
mlnor	- 555	Parkinsoniánum	- 148, 203	cauléscens	- 147
Cýcas revóluta	- 652	péndulum	- 295	Goldfússia capitáta	- 148
Cyclogýne canéscens	- 293, 593	Stamfordiánum	- 345	glomeráta	- 148
Cycnódus Loddigésii	- 360	vitellium	- 345	Gonolobus hispídus	- 202
maculáta	- 149	Epiphora pubéscens	- 551	Grammatophýllum multi-	
Cymbidium crassifólium	- 295	Epiphýllum Akermánni	- 551	fórum	- 21
mádidum	- 149	máior	- 310	Grevillea dúbia	- 295
péndulum	- 295	Jenkiúsdni	- 597	Griffithsia flabelláta	- 297
pubéscens	- 595	látifrons	- 548	Schousbœi	- 297
Cýnodon Dáctylon	- 349	speciosum	- 689	Gymnócladus canadénsis	- 225
Cynoglossum longifórum	- 549	E'ria planicaulis	- 148	Habránthus cearénsis	- 150
Cyrtánthus Smithiánum	- 150	Erica arístata	- 548	Hæmánthus toxicárius	- 475
Cyrtóceras reflexum	- 549	cinérea	- 102	Halézia tetráptera	- 600
Cyrtocóchilum bictioniénsis	- 550	élegans	- 310	Hardenbèrgia digitáta	- 547, 593
maculátum var. Russel-		Hartnélli	- 310	Hèdera Hèlix	- 102
iánum	- 345	hyemális	- 271	Heimia salicifolia	- 590
mystacnum	- 21	infáta fimbriáta	- 294	Heracleum aspèrrimum	- 45
Russèlii	- 345	Lambertiána rubéscens	- 549	gigántum	- 336
Cystánthe sprengelióides	- 594	Macnabiána	- 548	Hibbertia virgáta	- 167
Cýtisis Adámi	- 289, 381	mirábilis	- 310	Hibiscus multifídus	- 343
Labúrnum	- 381, 556	Tétralix	- 102	violáceus	- 689
purpúreus	- 289, 381, 556	Thunbèrgia	- 310	Wráyæ	- 546
racemósus	- 293	vágans	- 476	Hippeástrum anómalum	- 346
scariósus	- 306	vestita	- 310, 689	solandraflórum	- 150
tribracteolátus	- 94	Ericaálton Sollyánum	- 349	Hohenbèrgia strobilícea	- 557
Wéldení	- 104	Eucalyptus paniculáta	- 305	Hólcus cæspitósus	- 94
Dáhlia Barkèria	- 20	resinifera	- 305	Sórghum	- 648
glabráta	- 294	robústa	- 305	Hórdeum Ægoceras	- 349
Dámara austrális	- 304	Eugènia nervosa	- 306	cælestè	- 669
Delessèria interrúpta	- 297	Eupatórium odoratíssimum	- 45	distichum	- 312
Delphinium chinénsis fl. pl.	- 546	Euphórbia amygdalóides	- 479	núdum	- 673
mesoleúcum	- 672	Brídní	- 239	núdum	- 312
Dendróbium ámplum	- 551, 596	jacquiniaflóra	- 239	trifurcátum	- 674
æ'mulum	- 551	pheníceá	- 240	vulgære nádum	- 673
Cambridgeánum	- 149	spléndens	- 239, 689	Hotèia japoníca	- 19
denúdim	- 482	Eùthales macrophýlla	- 548	Hòvea Cèlsi	- 689
Devonánum	- 551	Fabiána imbricáta	- 21	Hóya carnosa	- 686
fimbriátum	- 149	Fàgus sylvática	- 565, 600	coriáceá	- 549
formósum	- 21	sylvática atropurpúrea	- 225	Hydrocótyle vulgáris	- 313
herbáceum	- 551	sylvática purpúrea	- 565	Hymenocállis Harrisidána	- 345
Pierárdi	- 271	Fernandèzia lunifera	- 22	rotáta	- 345
plicátile	- 149	Ficus Sycómorus	- 601, 650	Hymenóxys califórnicá	- 594
revólutum	- 551	elástica	- 652	Hypphæne coriáceá	- 660
tères	- 551	Fúchsia arboréscens	- 238	Impatiens glanduligera	- 293
vaginátum	- 595	delvinénsis	- 689	longicórnu	- 145
Dendrochilum filifórme	- 551	Devónia	- 679	macrochila	- 145
Deutzia corymbosa	- 146, 605	erécta	- 609	Nolitángere	- 146
parviflóra	- 146	excorticáta	- 238	picta	- 19, 145
unduláta	- 605	floribúnda magna	- 609	trícornis	- 145
Dicrýpta discolor	- 22	fúlgens	- 146, 238, 689	Impoæa Batátas	- 237
Dillýrnia speciosa	- 201	globosa	- 146, 686	Leárii	- 147, 549, 604
Dinèma palæceum	- 551	fúlgida supérba	- 609	longifólia	- 295
Dionæa muscipula	- 689	grandiflóra máxima	- 609	púrگا	- 20
Dioscòrea aculeáta	- 652	longifólia élegans	- 609		
Diplopéltis Hugèlii	- 19				

<i>Ip. rubro-cærulea</i> - - - 147	<i>Mah. fasciculãris</i> - - - 100	<i>Onc. ornithorhynchum</i> - - 148
<i>Iris deflexa</i> - - - 345	<i>røpens</i> - - - 589	<i>pachyphýllum</i> - - - 550
<i>frãgrans</i> - - - 150	<i>fasciculãris</i> - - - 100	<i>pállidum</i> - - - 550
<i>germãnica</i> var. <i>nepa-</i>	<i>Málva crispa</i> - - - 38	<i>papillo</i> - - - 202
<i>lønisa</i> - - - 345	<i>mauritiãna</i> - - - 38	<i>ramòsum</i> - - - 550
<i>Hùmci</i> - - - 345	<i>moschãta</i> - - - 201	<i>ròscum</i> - - - 148
<i>nepalønisa</i> - - - 345	<i>peruviãna</i> - - - 38	<i>stramineum</i> - - - 202
<i>reticulãta</i> - - - 552	<i>Mammillãria latispina</i> - 26	<i>Ophèlia purpurãscens</i> - 549
<i>sibirica</i> - - - 156	<i>rãdiãns</i> - - - 658	<i>Opúntia ferox</i> - - - 482
<i>Ismèni calathina</i> - - - 475	<i>Mandevilla suavolens</i> - 147	<i>Ornithògalum umbellatum</i> 303
<i>deflexa</i> - - - 22	<i>Manglìtia glabrãta</i> - - 202	<i>Orobãnce minor</i> - - - 554
<i>Knighiti</i> - - - 345	<i>Marãnta arundinãcea</i> - 652	<i>Orthosiphon incúrvus</i> - 344
<i>Jãtropa pandurãfolia</i> - 237	<i>Mãrica hùmilis</i> var. <i>lũtea</i> - 552	<i>Osbèckia canescens</i> - - 20
<i>Jãncus conglomerãtus</i> - 259	<i>lũtea</i> - - - 552	<i>O'xalis crenãta</i> - - - 446
<i>polycèphalus</i> - - - 664	<i>Maxillãria aromãtica</i> - 552	<i>geniculãta</i> - - - 556
<i>Juniperus communis</i> - 102	<i>cucullãta</i> - - - 148	<i>Ottønisa</i> - - - 556
<i>excelsa</i> - - - 656	<i>Macièri</i> - - - 552	<i>tuberosa</i> - - - 301
<i>phœnicea</i> - - - 656	<i>Skinneri</i> - - - 552. 677	<i>Oxyãnthus versicolor</i> - 548
<i>thurifera</i> - - - 656	<i>tenuifolia</i> - - - 552	<i>Pœonia Moitani</i> 305. 451. 481
<i>virginiãna</i> - - - 225	<i>Medicãgo lupulina</i> - - 278	<i>Pancrãtium luteum</i> - - 22
<i>Justicia curviflora</i> - - 202	<i>Melaleuca Cajaputi</i> - - 652	<i>rotatum</i> - - - 345
<i>Kadsãra japonica</i> - - 638	<i>Mèlia Azèderach</i> - - - 305	<i>Pandãnus odoratissimus</i> - 306
<i>Kennedyã glãbra</i> - - - 689	<i>Melilotus álba altissima</i> - 610	<i>sylvèstris</i> - - - 306
<i>Marryãttã</i> - - - 689	<i>mørbea</i> - - - 16. 567	<i>Passiflora alãta</i> - - - 236
<i>rubicũnda</i> - - - 689	<i>leucãnthã</i> - - - 610	<i>cærulea</i> - - - 146
<i>Kleinhhõfia hõspita</i> - - 306	<i>officinãlis</i> - - - 46	<i>edulis</i> - - - 547
<i>Labãrnium bullãtum</i> - - 609	<i>Melocãctus vivipara</i> - - 482	<i>incarnãta</i> - - - 547
<i>Læ'lia cinabãrina?</i>	<i>Mèspilus canariønisa</i> - - 45	<i>kermesina</i> - - - 236
<i>álva</i> - - - 22	<i>Meyera Hawtaynedãna</i> - 594	<i>Mooreana</i> - - - 146
<i>rubescens</i> - - - 203. 551	<i>Micròstyli histionãnthã</i> - 556	<i>verrucifera</i> - - - 547
<i>superba</i> - - - 345	<i>Miltõnia cãndida</i> - - - 21	<i>Patersõnia sapphirina</i> - 22
<i>Lagerstrœ'mia índica</i> - 23. 306	<i>cãndida flavescens</i> - 296	<i>Paulõwnia imperiãlis</i> - 657
<i>regina</i> - - - 306	<i>Mimulus cardinãlis</i> - - 408	<i>Pèganum Hãrmala</i> - - 556
<i>Lãlage ornãta</i> - - - 238	<i>Monacãnthus longifolius</i> - 550	<i>Pentlãndia miniãta</i> - - 23. 360
<i>Lãrice americana rubra</i> - 304	<i>ròsc-ãlbus</i> - - - 296. 550	<i>Pentstèmon argutus</i> - - 147
<i>europeã sibirica</i> - - 304	<i>viridis</i> - - - 551	<i>gentianõides coccinea</i> - 45
<i>Lasiãndra Maximiliãna</i> - 20	<i>Morinã longifolia</i> - - - 344	<i>Petrœa Staplècie</i> - - - 27
<i>petiolãta</i> - - - 19	<i>Mormòdes buccinãtor</i> - 149	<i>Phacèlia tanacetifolia</i> - 394
<i>Zãurus nõbilis</i> - - - 100	<i>Moròdechys capitãta</i> - 168	<i>Phalænõpsis amãbilis</i> - 310
<i>Pèrsica</i> - - - 301	<i>Morus álba</i> - - - 307	<i>Pharbitis Læari</i> - - - 549
<i>Lawrènciã spicãta</i> - - 168	<i>cucullãta</i> - - - 307	<i>Phylãdelphus mexicanus</i> - 293
<i>Lemõnia spectãbilis</i> - - 593	<i>Morettiãna</i> - - - 508	<i>Phlõx Coldryãna</i> - - - 594
<i>Lennèa umbellãta</i> - - 557	<i>multicaulis</i> - 226. 307. 308	<i>cordãta</i> - - - 594
<i>Lepismium communè</i> - - 20	<i>papyrifera</i> - - - 45	<i>Phlogacãnthus curviflorus</i> 202
<i>Leptodermis lanceolãta</i> - 20	<i>Seringeãna</i> - - - 554	<i>Phœ'nix dactylifera</i> - - 650
<i>Leptosiphon androsãceus</i> - 394	<i>tinctõria</i> - - - 652	<i>Photinia serulãta</i> - - - 671
<i>densiflorus</i> - - - 394	<i>Musa Cavendishii</i> - - 609	<i>Phytolobium carinãtum</i> - 547
<i>Leptòtes bicolor</i> - - - 149	<i>paradiasiãca</i> - - - 609	<i>Phyteuma albidiflorum</i> - 225
<i>Liatris hirsuta</i> - - - 594	<i>rosãcea</i> - - - 609	<i>puichellum</i> - - - 146
<i>propinqua</i> - - - 594	<i>superba</i> - - - 608	<i>Picea cephalõnica</i> 296. 568. 656
<i>spicãta</i> - - - 594	<i>Muscãri botryõides</i> - - 303	<i>pectinãta tortuõsa</i> - 304
<i>Lichen radicifõrmis</i> - 174	<i>comsum</i> - - - 303	<i>Pinsãpo</i> - - - 94. 296. 658
<i>Zigistrium chinènsè</i> - - 45	<i>Mýnthus cernuus</i> - - - 310	<i>Webbiãna</i> - - - 588
<i>lũcium</i> - - - 672	<i>spindus</i> - - - 344. 550	<i>Pimelèa incãna</i> - - - 21
<i>Lilium eximium</i> - - - 346	<i>Mycarãntes obliqua</i> - - 595	<i>nivea</i> - - - 21
<i>lancifolium</i> - - - 449	<i>Mýrtus Pimènta</i> - - - 652	<i>Pincknèya pübens</i> - - - 306
<i>speciosum albiflorum</i> - 203	<i>Nelãmbium álbum</i> - - - 304	<i>Pingufcula vulgãris</i> - - 313
<i>Liparis Walkèrie</i> - - - 21	<i>speciosum</i> - - - 689	<i>Pinus australis</i> - - - 549
<i>Liriõdendron Tulipifera</i> - 600	<i>rùbrum</i> - - - 304	<i>austriãca</i> - - - 656
<i>Lissãnthè stellãta</i> - - - 146	<i>Nemõphila insignis</i> - - 294	<i>Banksiãna</i> - - - 656
<i>verticillãta</i> - - - 202	<i>Nephrodium fũlvum</i> - - 361	<i>canariønisa</i> - - - 656
<i>Lissochilus parviflorus</i> - 345	<i>Nicotiãna rustica</i> - - - 410	<i>Cèmbra</i> - - - 659
<i>Littæa geminiflora</i> - - 306	<i>Tabãcum</i> - - - 410	<i>sibirica</i> - - - 304
<i>Lobèlia discolor</i> - - - 556	<i>Nitrãria Schõberi</i> - - 657	<i>cephalõnica</i> - - - 277
<i>igneã</i> - - - 20	<i>Nuttãllia malvãeflora</i> - 201	<i>Chýlla excelsa?</i> - - - 304
<i>multiãdra</i> - - - 146	<i>Nymphæa carulea</i> - - - 288	<i>microcarpa</i> - - - 304
<i>Lonicera Periclymenum</i> - 102	<i>Oberõntia cylindrica</i> - 203	<i>serõtina</i> - - - 304
<i>Lopezia lineãta</i> - - - 293. 547	<i>Octomèria diãphana</i> - - 22	<i>Coùteri</i> - 304. 550. 590. 656
<i>Lõtus ornithopodiõdes</i> - 42	<i>Odontoglõssum bictoniènsè</i> 550	<i>excelsa</i> - - - 656
<i>Lublinã atropurpũrea</i> - 99	<i>Clowèsi</i> - - - 22	<i>filifolia</i> - - - 549
<i>Lupulus Barkèrie</i> - - - 19	<i>grãnde</i> - - - 345	<i>Lambertiãna</i> - - - 652
<i>leptocãrpus</i> - - - 546	<i>maculãtum</i> - - - 296	<i>Laricio</i> - - - 652
<i>rivularis</i> - - - 546	<i>Enothèra biønns</i> - - - 555	<i>Lemoniãna</i> - - - 395
<i>Lýchnis diũrna</i> - - - 447	<i>O'lea fragrans</i> - - - 359	<i>longifolia</i> - - - 656. 689
<i>Lycopodium complanãtum</i> - 580	<i>Olfuã capènsis</i> - - - 556	<i>macrocarpa</i> - 550. 588. 590
<i>Lysimãchia atropurpũrea</i> - 99	<i>Oncidium altissimum</i> - 148	<i>monticola</i> - - - 656
<i>brachystachys</i> - - - 99	<i>Batemanianum</i> - - - 148	<i>nepalønisa</i> - - - 306
<i>Mãdia sativa</i> - - - 38	<i>carthaginènsè</i> - 344. 556	<i>nigra</i> - - - 432
<i>Magnõlia auriculãta</i> - - 481	<i>Cavendishianum</i> - - 550	<i>Pallasiãna</i> - - - 656
<i>conspicua</i> - - - 481. 584	<i>divaricãtum</i> - - - 310	<i>palũstris</i> - - - 549
<i>Soulangeãna</i> - - - 584	<i>excavãtum</i> - - - 22	<i>pãtula</i> - - - 304
<i>glãuca</i> - - - 481	<i>Harrisonianuw</i> - - - 550	<i>Pinãster Lemonianus</i> - 395
<i>grandiflora</i> - 305. 420. 600	<i>Huntianum</i> - - - 344. 550	<i>Pinãster variegãtus</i> - 304
<i>macrophylla</i> - - - 584	<i>incúrvus</i> - - - 595	<i>Pinsãpo</i> - - - 277
<i>Thompsoniãna</i> - - - 481	<i>Inslèayi</i> - - - 202	<i>ponderosa</i> - - - 304
<i>tripètala</i> - - - 481	<i>Lanceanum</i> - - - 360. 408	<i>pumilio</i> - - - 656
<i>Mahõnia Aquifolium</i> - 100. 589	<i>nubigenum</i> - - - 482	<i>Sabiniãna</i> - - - 588. 590. 656

<i>Pin. Stròbus pygmæa</i> - 304	<i>Rob. hisp. mājor</i> - 13	<i>Spir. sorbifolia</i> - 547
<i>sylvëstris</i> - 666	<i>inermis</i> - 13	<i>vacciniiflora</i> - 202
<i>Pistácia officinarum</i> - 306	<i>rùbra</i> - 13	<i>vacciniifolia</i> - 547
<i>Pittòsporum Tobira</i> - 305	<i>viscosa</i> - 13	<i>Spiránthes Lindleyana</i> - 557
<i>Pleurothállis pachyglòssa</i> - 552	<i>alba</i> - 13	<i>Spironëma fràgrans</i> - 346, 553
<i>scábripes</i> - 22	<i>Rodriguezia crispa</i> - 22, 552	<i>Sprekèlia cybister</i> var. brè.
<i>seriàta</i> - 595	<i>laxiflora</i> - 22	<i>vis</i> - 346
<i>Podocarpus taxifolius</i> - 660	<i>Rondeletia odorata</i> - 360	<i>formosissima</i> - 398
<i>Polemoniùm caruleum</i> var.	<i>Ròsa canina</i> - 309	<i>glauca</i> - 552
<i>grandifolium</i> - 344	<i>multiflora</i> - 309	<i>Stanthòpea gravèolens</i> - 551
<i>Pòpulus canescens</i> - 666	<i>odoratissima</i> - 309	<i>insignis</i> - 174
<i>fastigiata</i> - 224	<i>sarmentacea</i> - 664	<i>Martiana</i> - 551
<i>græca</i> - 231	<i>tomentosa</i> - 102	<i>saccata</i> - 551
<i>Portulaca Thellusonii</i> - 343	<i>Rùbus arcticus</i> - 168	<i>Státice arborea</i> - 608
<i>grandiflora rùtila</i> - 343	<i>Gunnianus</i> - 168	<i>Stenomèsson latifolium</i> - 346
<i>Potentilla fruticosa</i> - 664	<i>Ruellia achyranthifolia</i> - 549	<i>Stephanòtis follicularis</i> - 360
<i>Pòthos digitata</i> - 306	<i>australis</i> - 549	<i>Stercùlia platanifolia</i> - 225
<i>Pourrètia carulea</i> - 150	<i>élegans</i> - 549	<i>Stèvia breviaristata</i> - 294
<i>Pronàya élegans</i> - 657	<i>parviflora</i> - 549	<i>Stranvæ'sia glaucescens</i> - 11
<i>Psidium pomiferum</i> - 652	<i>Rùscus aculeatus</i> - 476	<i>Strelitzia júncea</i> - 237
<i>Ptèlea trifoliata</i> - 45	<i>Saccolabium compressum</i> - 149	<i>Stromatophæ'ria multiceps</i> - 390
<i>Paya Altensteinii</i> - 556	<i>denticulatum</i> - 552	<i>Styrax officinale</i> - 303
<i>carulea</i> - 150	<i>guttatum</i> - 360	<i>Tacsonia pinnatistipula</i> - 236
<i>Pyrus Polveria</i> - 605	<i>præmorsum</i> - 360	<i>Tanacetum longifolium</i> - 344
<i>Bolwylliana</i> - 605	<i>Salisbùria adiantifolia</i> - 225	<i>Taxus baccata</i> - 659
<i>Quercus Brantii</i> - 344	<i>Sàlix aquatica</i> - 102	<i>fastigiata</i> - 656
<i>Cèrris</i> - 219, 559, 600	<i>aurita</i> - 102	<i>canadensis</i> - 660
<i>fastigiata viridis</i> - 100	<i>fùsa</i> - 102	<i>montana</i> - 659
<i>heterophylla</i> - 100	<i>herbacea</i> - 102	<i>nucifera</i> - 660
<i>Flex</i> - 100, 666	<i>Salsòlia genistoides</i> - 92	<i>Tèctona grandis</i> - 652
<i>palustris</i> - 584	<i>Sàlvia bicolor</i> - 549	<i>Terminalia angustifolia</i> - 306, 652
<i>pedunculata</i> - 354, 665, 672	<i>fùlgens</i> - 475	<i>Tetracarpæa tasmànica</i> - 168
<i>pedunculata pèndula</i> - 567	<i>hians</i> - 549	<i>Tetramèrium odoratissi-</i>
<i>règia</i> - 344	<i>Hornlnum</i> - 303	<i>mum</i> - 374
<i>rígida</i> - 344	<i>leucantha</i> - 475	<i>Thalictrum cultratum</i> - 343
<i>Ròbur</i> - 665	<i>leucocéphala</i> - 475	<i>Theophràsta americana</i> - 306
<i>rùbra</i> - 656	<i>linarioides</i> - 295	<i>Thunbèrgia alata</i> - 148
<i>rugosa</i> - 101	<i>longiflora</i> - 475	<i>aurantiaca</i> - 347
<i>sessiflora</i> - 354, 583, 668	<i>pàtens</i> - 45, 224, 475	<i>grandiflora</i> - 181
<i>tinctoria</i> - 656	<i>pátula</i> - 21	<i>Hawtayneana</i> - 594
<i>virens</i> - 100	<i>persicifolia</i> - 475	<i>Thysanòtus intricatus</i> - 23
<i>Ranunculus àcris</i> - 418	<i>phœnicea</i> - 475	<i>Tilia americana</i> - 100
<i>Renanthera coccinea, cult.</i> - 203	<i>pubescens</i> - 475	<i>europæa grandifolia</i> - 100
<i>Rhipidodèndron plicatilis</i> - 657	<i>Règia</i> - 475	<i>Tillandsia dianthoida</i> - 306
<i>Rhinanthus mājor</i> - 664	<i>Sèssel</i> - 475	<i>Tofèldia palustris</i> - 664
<i>Rhizoctonia Medicaginis</i> - 555	<i>speciosa</i> - 475	<i>Torrèya taxifolia</i> - 658
<i>Crocòrum</i> - 555	<i>Sarcánthus oxyphylus</i> - 552	<i>Tradescàntia iridescens</i> - 346
<i>Rhizomòrpha subterranea</i> - 173	<i>pállidus</i> - 595	<i>spicata</i> - 23
<i>Rhodánthe Manglesi</i> - 45	<i>rostratus</i> - 552	<i>tùmida</i> - 553
<i>Rhododèndron Acklandi</i> - 481	<i>Sarcòchilus unguiculatus</i> - 552	<i>Treviana coccinea</i> - 548
<i>album</i> - 686	<i>Satyrion pustulatum</i> - 203	<i>Trientalis europæa</i> - 664
<i>altaclerense</i> - 237	<i>Saxifràga umbròsa</i> - 664	<i>Trifolium involucratum</i> - 547
<i>arboreum</i> 271, 305, 310, 477, 481, 594, 598, 657, 681, 686	<i>hirculus</i> - 664	<i>macrocalyx</i> - 168
<i>hybridum</i> - 269	<i>Schizòndtus tomentòsus</i> - 547	<i>procumbens</i> - 278
<i>caucasicum</i> - 548	<i>Scflia officinale</i> - 303	<i>Trigonidium ringens</i> - 551
<i>hybridum</i> - 548	<i>Scòttia dentata</i> - 237	<i>Triptilion spinosum</i> - 548
<i>màximum</i> - 311	<i>Sedum Cotyledon</i> - 418	<i>Triticum sativum</i> - 38
<i>pònticum</i> - 352	<i>multicaule</i> - 548	<i>Tropæ'olum tricolòrum</i> - 311
<i>albiflorum</i> - 548	<i>villòsum</i> - 664	<i>tuberòsum</i> - 271, 446
<i>Rhus Còtinus</i> - 514	<i>Sempervivum variegatum</i> - 681	<i>U'lex europæa</i> - 102, 481
<i>Ribes aureum</i> - 12	<i>Senècio Heritièr</i> - 594	<i>strictus</i> - 481
<i>glutinòsum</i> - 394	<i>Shepherdia canadensis</i> - 45	<i>U'lmus campèstris</i> - 44, 473
<i>malvaceum</i> - 11, 394	<i>Sida Abùtilon</i> - 38	<i>alba</i> - 44
<i>nigrum</i> - 99	<i>vitifolia</i> - 546	<i>acutifolia</i> - 44
<i>petraeum</i> - 664	<i>Silène régia</i> - 68	<i>stricta</i> - 44
<i>rùbrum</i> - 99	<i>Sinningia velutina</i> - 294	<i>virens</i> - 44
<i>speciosum</i> - 12	<i>Youngeana</i> - 294	<i>viminalis</i> - 44
<i>Rigidèlia flàmmea</i> - 203, 345	<i>Sisyriuchium majale</i> - 557	<i>fùlva</i> - 231
<i>Robèrgia Pànca</i> - 306	<i>Solàndra guttata</i> - 27	<i>glabra</i> - 473
<i>Robinia Pseud-Acacia</i> - 13	<i>Solanum angustifolium</i> - 594	<i>mājor</i> - 44
<i>Ps. amorphæfolia</i> - 13	<i>macranthum</i> - 594	<i>pèndula</i> - 44
<i>crispa</i> - 13	<i>tuberòsum</i> - 259, 204	<i>vègeta</i> - 44
<i>echinata</i> - 13	<i>uncinellum</i> - 202	<i>montana</i> - 44, 600
<i>floribunda</i> - 13	<i>Sòllya angustifolia</i> - 145	<i>crispa</i> - 44
<i>formosissima</i> - 13	<i>heterophylla</i> - 145	<i>fastigiata</i> - 44
<i>gracilis</i> - 13	<i>linearis</i> - 19, 145	<i>mājor</i> - 44
<i>heterophylla</i> - 13	<i>Sophòra japonica pèndula</i> - 657	<i>minor</i> - 44
<i>microphylla</i> - 13	<i>Sòrbus aucuparia</i> - 102	<i>pèndula</i> - 44
<i>procera</i> - 13	<i>Sparaxis grandiflora</i> - 257	<i>rugosa</i> - 44
<i>pyramidalis</i> - 13	<i>tricolor</i> - 257	<i>suberosa</i> - 473
<i>sophoræfolia</i> - 13	<i>Spàrtium æthnense</i> - 281	<i>vulgàris</i> - 44
<i>spectabilis</i> - 13	<i>Specklinia obovata</i> - 22	<i>foliis variegatis</i> - 44
<i>tortuosa</i> - 13	<i>Spiræa barbata</i> - 19	<i>alba</i> - 44
<i>longifolia</i> - 13	<i>ftsa</i> - 593	<i>Faccinnum humifusum</i> - 268
<i>dùbia</i> - 13	<i>laxiflora</i> - 202	<i>Imrayi</i> - 168
<i>hispida</i> - 13	<i>Lindleyana</i> - 547	<i>Myrtillus</i> - 102
	<i>rotundifolia</i> - 547	<i>Nàpus</i> - 594

Vallöta purpürea - - - 475	Viétoria régia - - - 566	Yúcca gloriösa - - - 101
Vánda Roxbürgüü - - - 310	Vínca májör - - - 479	Zámia angustifolia - - - 90
téres - - - 360. 551	Víola flavicórnis - - - 672	púngens - - - 306. 365
Verbáscum táuricum - - - 295	canina - - - 672	Ziétia lævigáta - - - 546
Verbéna amœ'na - - - 147	Vítex A'gnus cástus - - - 99	Zingiber officinális - - - 652
Metúndres - - - 361	Wistária Consequána - - - 686	Zizyphus nepalénsis - - - 306
teucríóides - - - 147	sinénsis - - - 311	Zygotépalum africanum - - - 590

LIST OF FRUITS.

Apples: —	Gooseberries: —	Pears: —
Adam's Pearmain - - - 264	Pitmaston Green Gage 264	Beurré de Noirochain - - - 266
Annat Scarlet - - - 175	Taylor's Bright Venus 264	Beurré Rance - - - 271
Boston Russet - - - 264	Grapes, <i>cult.</i> - 89. 435. 598. 613	Bringewood - - - 408
Braddick's Nonpareil - - - 264	Ahbec - - - 469	Broom Park - - - 408
Downton Pippin - - - 410	Black Damascus - - - 571	Brougham - - - 408
Dutch Mignonne - - - 264	Black Esperione - - - 176	Brown Beurré - - - 402. 411
Forman's Crew - - - 264	Black Frontignan 265. 176	Cardillac - - - 174
Fulwood - - - 271	Black Hamburg - 61. 101.	Chaumontel - - - 402
Herefordshire Pear-	- 265. 570	Colmar - - - 402
main - - - 264	Black Lombardy - 61. 265	Crassane - - - 402. 411
Hughes's Golden Pippin 264	Black Morocco - - - 265	Croft Castle - - - 408
King Pippin - - - 264	Black Muscadel - - - 107	Double fleur - - - 174
Maclean's Favourite - 410	Black Prince - 107. 176	Duchesse d'Angoulême
Margil - - - 264	Black Raisin - 107. 265	- - - 174. 616
Nonpareil - - - 271	Black Tripoli - - - 571	Dunmore - - - 408
Old Golden Pippin 264. 271.	Cannon Hall Muscat 61. 265	Eyewood - - - 408
410	Charlesworth Tokay - 411	Incomparable Beurré - 266
Old Nonpareil - - - 264	Grizzly Frontignac - 265	Jargonelle - 390. 402. 411
Orange Btenheim - - - 271	New Black Cluster - 411	March Bergamot - 408
Oslin - - - 264	Oldaker's West's St.	Moccas - - - 408
Pomme-roy - - - 271	Peter's - - - 107	Monarch - - - 408
Red Cluster - - - 271	Purple Constantia 265. 570	Monsieur le Curé - 410
Ribston Pippin 61. 264. 271.	Stillwell's Sweetwater - 571	Oakley Park Bergamot 408
278	Syrian - - - 571	Pengethley - - - 408
Spencer Pippin - - - 271	Tokay - - - 265	Poire de Cleon - - - 410
Sudbury Beauty - - - 410	West's St. Peter's 265. 571	St. Germain - - - 402
Summer Golden Pippin 264	White Constantia - - - 570	St. Lezin - - - 410
Sweezy Nonpareil - 264	White Frontignan 265. 570	Summer Bergamot - 290
Winter Redstreak - 271	White Muscadine - - - 176	Swan's Egg - - - 390
Yorkshire Green - 271	White Muscat 176. 265. 411.	Uvedale's St. Germain - 410
Apricots: —	570	Van Mons Léon le
Breda - - - 264	White Portugal - - - 571	Clerc - - - 174. 616
Brussels - - - 61. 278	White Raisin - - - 266	Windsor - - - 390
Early Red - - - 264	White Sweetwater 265. 570	Pines: —
Hemskirke - - - 264	Wortley Hall - - - 107	Pommerail - - - 609
Large Peach - - - 264	Melons, <i>cult.</i> - - - 204	Queen - - - 129
Large Red - - - 264	Egyptian Green Flesh 422.	Plantain: —
Moorpark 61. 264. 278. 280.	424	Dacca - - - 175
376	Ispahan - - - 422. 468	Plums: —
Turkey - - - 264	Kew Cantaloup - - - 424	Denyer's Victoria - 266
Cherries: —	King's Favourite - - - 424	Dunmore - - - 408
Belle de Choisy - - - 264	Old Scarlet Flesh - - - 422	Green Gage - - - 266
Bigarreau - - - 520	Romana - - - 423	Impératrice - - - 61. 278
Black Eagle 264. 375. 462.	Mulberry - - - 566	Reine Claude - - - 266
520	Mûsa. See Plantain.	Pumpkin - - - 670
Black Tartarian - 264	Nectarines: —	Strawberries: —
Downton - - - 264	Impératrice - - - 401	Alpine, <i>cult.</i> - 89. 609
Early Purple Guigne - 264	Violette hátive - - - 266	American Scarlet - 266
Elton - - - 264. 375	Orange - - - 224. 268. 660	Black Roseberry - 266
Kentish - - - 520	Peach, <i>cult.</i> - - - 399	Coul late Scarlet - 266
May Duke - - - 520	Bellegarde - - - 266	Elton's Seedling - - 296
Morello - - - 582	Gallade - - - 266	Garnstone Scarlet - 266
Dates - - - 649	New variety - - - 312	Grove End Scarlet 266. 470
Figs - - - 582	Pears: —	Keen's Seedling, <i>cult.</i> 469.
Nerri, <i>cult.</i> - - - 468	Althorp Crassane - 412	582. 609.
Gooseberries: —	Autumn Bergamot 390. 411	Kew Pine - - - 582
Crompton's Sheba	Bergamotte de Pâques 402	Myatt's Pine - 296. 302. 411
Queen - - - 264	Beurré de Flandres - 266	Swainston Seedling - 609

LIST OF CULINARY VEGETABLES.

Artichoke, Jerusalem, <i>cult.</i> 259	Caper, <i>cult.</i> - - - 46	Celery: —
Asparagus - - - 156	Carrot - - - 47. <i>cult.</i> 207. 302	Seymour's White, <i>cult.</i> 91
Beet - - - 666	Early Dutch Horn - 461	Turnip-rooted - - - 296
Borecole - - - 296	White, <i>cult.</i> - - - 209	Chicory, <i>cult.</i> - - - 90
Broccoli - - - 41	Wild - - - 296	Gourd - - - 296
Brussels Sprouts - 57, 461		Mushrooms - 271. <i>cult.</i> 371. 420

Onions : —	437. 650	Potatoes : —		Spinach	437
Potato	663	Rohan	98	Truffles	420
Turkey, <i>cult.</i>	207	Sweet	296	Turnips, <i>cult.</i>	472
Peas	433	Wild	259	Roughhead's Swedish	48
Potato, <i>cult.</i> 210. 277. 278. 346. 376.		Scotch Kale	57	Yellow Dutch	104
<i>cult.</i> 390. <i>cult.</i> 395. <i>cult.</i> 415		Shallot	296		

LIST OF AGRICULTURAL PLANTS.

Clover : —		<i>Hörd</i> , <i>vulgäre</i>	674	<i>Melilotus arbdrea</i>	567. 610.
Bokhara	46. 101. 670	<i>nüdum</i>	673		670
Black nonsuch	278	<i>trifurcätum</i>	674	<i>officinälis</i>	46
yellow	278	Indian Corn	670	<i>Triticum sativum</i>	38
<i>Hördeum distichum</i>	31½	Madder	649	Wheat, new kinds of	38
<i>nüdum</i>	673	<i>Mädia sativa</i>	38		

LIST

OF HORTICULTURAL, BOTANICAL, AND FLORICULTURAL SOCIETIES.

Aberdeenshire Hort.	686	Fête Champêtre in the Bel-	690	Pitlessie Hort.	688
An dover Hort.	680	fast Bot. Gard.	690	Pittville Hort. Assoc.	680
Barrowford Pink Show	681	Fife Hort. and Flor.	687	Redford and Bawtry Hort.	682
Bath Royal Hort. and Bot.	682	Forres and Nairn Hort.	688	Royal Hort. Soc. of Ireland	690
Bath Hort.	683	Gateshead Ancient Florists'		Royal Perthshire Hort.	688
Beeston and Chilwell Flower		Society	680	Salop Flor. and Hort.	682
Show	682	Grantham Flor. and Hort.	682	Sandbach Flor. and Hort.	676
Berks Royal Hort.	676	Grantham Carnation Show	682	Sheffield Hort.	684
Biggleswade Hort.	676	Guernsey Hort.	685	Sheffield Class Dahlia Show	684
Birmingham Grand Dahlia		Hampstead Flor.	682	Sheffield Tulip Show	684
Exhibition	684	Hants Hort.	680	Sheffield Pink Show	684
Birmingham Gooseberry		Hartwell Gooseberry Show	676	South Essex Hort.	680
and Flower Show	684	Heath Tulip Show	684	St. Andrew's Hort.	682
Brechin Hort.	688	Herts Hort.	680	and Flor.	682
Bristol and Clifton Dahlia		Hexham Flor. and Hort.	682	St. Andrew's Hort. and Flor.	688
Show	683	Hinckley Hort. and Flor.	682	Stafford Flor. and Hort.	683
Burton-upon-Trent Hort.	683	Horncastle Flor. and Hort.	682	Stamford Flor. and Hort.	682
Caledonian Hort.	685	Huntingdonshire Hort.	681	Stirling Hort.	690
Cambridge Florists' Soc.	676	Ipswich Flor.	684	St. Neot's Hort.	681
Cambridge Annual Dahlia		Jersey Agric. and Hort.	685	Stockport Annual Tulip	
Show	676	Kelso Hort.	689	Show	676
Cambridge Hort.	676	Kennoway Flor. and Hort.	687	Stowmarket Hort. Soc.	684
Cheltenham Hort. and Flor.	680	Kent and Canterbury Flor.		Sunderland Flor. and Hort.	680
Chester Flor. and Hort.	676	and Hort.	681	Trecan Cottage-Gardening	677
Chesterfield Gooseberry		Kilkenny Hort.	690	Uttoxeter Hort. and Flor.	684
Show	678	Kilmadock and Kincardine		Vale of Evesham Hort. and	
Cirencester Hort.	680	in Monteith Cottage, and		Flor.	684
Cirencester Hort. Associa-		Farm Garden	687	Wakefield Flor.	684
tion	680	Kingston Flor. and Hort.	684	Wallington Pink Show	684
Clackmannanshire Hort.	686	Leicestershire Flor. and		Warrington Tulip and Hort.	681
Cornwall Royal Hort.	676	Hort.	682	West Kent Pnk	681
Coventry Hort.	684	Lynn Hort.	682	West London Amateur	
Croydon Dahlia Show	684	Maidstone Hort.	681	Dahlia	682
Derby Gooseberry Show	678	Market Drayton Hort. and		West Renfrewshire Hort.	689
Devon and Cornwall Royal		Flor.	682	Whitefield Pansy Show	682
Hort.	678	Melbourne Flor. and Hort.	682	Whitehaven Flor. and Hort.	678
Doncaster Hort.	684	Melbourne Gooseberry Show	682	Wilts Hort.	684
Dover Hort.	681	Metropolitan Soc. of Florists	682	Winchester Pansy Show	680
Dumfries and Galloway		Middleton Tulip Show	682	Winchester Auricula Show	680
Hort.	686	Middleton Gooseberry Show	682	Wingham Hort. and Flor.	681
Dundee Flor. and Hort.	688	Newcastle Bot. and Hort.	682	Wolverhampton Hort.	684
East Surrey Florists' Soc.	687	Norfolk and Norwich Hort.	682	Wolverhampton Tulip Show	684
Eltham Hort. and Flor.	681	Norwich Flor. and Hort.	676	Worcestershire Hort.	684
Exeter Hort.	680	Norwich Dahlia Show	682	Wrexham Hort.	685
Exeter Grand Dahlia Ex-		Nottingham Flor. and Hort.	682	York Hort.	684
hibition	680	Old Lenton Gooseberry		York Hort. Exhibition	684
Falkirk Hort.	689	Show	682	York Amateur Flor.	684
Felton Flor.	682	Oxfordshire Hort.	682		

1840. DEC.

LIST OF GARDENS AND COUNTRY SEATS.

Abbotsbury - - - 477	Dean - - - 331	Hatfield - - - 331
Alton Towers - 103. 230. 280.	Deepdene - - - 311	Hayes - - - 328
- - - 342. 580	Downton Castle - - - 396	Highbere - - - 493
Apthorpe - - - 331	Dropmore - - - 8. 476	Holkham Hall - - - 666
Arboretum, Derby - 15. 47. 59.	Dyrham Park - - - 90	Holland Park - - - 566
- - - 73. 521	Dysart House - - - 271	Holyrood - - - 362. 563
Arno's Grove - - - 584	Earlham Hall - - - 600	Hoole House - - - 586
Arundel Castle - - - 477	East Comb - - - 342. 581	Hopetoun - - - 174
Ascot Place - - - 586	Eatington Park - - - 389	Horsforth Hall - - - 265
Ashridge - - 24. 88. 90. 207	Elvaston Castle - - - 572	Howick Hall - - - 196
Aylsham - - - 668	Enville - - - 514	Hungerton Hall - 329. 342. 569
Bagshot Park - - - 593	Eyewood - - - 377	Hyde Park - - - 566
Bayfordbury - - - 588	Fence - - - 189	Kensington Palace - 566
Bedgebury Park - - - 311	Fonthill - - - 586. 615	Kenwood - - - 90
Beech Hill - - - 342	Portis Green, Muswell Hill 49	Keswick - - - 662
Beech Hill Park - - - 584	Porton Cottage - - - 672	Kingsbury - 20. 131. 229. 233.
Beech Lawn - - - 585	Gardens : -	277. 293. 345. 419. 548
Belford - - - 342. 583	Imperial Vienna - - 597	Kirby - - - 331
Belsay Castle - - - 476	Kensington - - - 570	Knepp Castle - - - 35. 101
Belton - - - 571	Leeds Zoological and	Knightley Park - - - 510
Belvidere - - - 342. 583	Botanical - - - 566	Knole - - - 35. 331
Belvoir Castle - - - 332	London Horticultural - 21.	Knypersly - - - 596
Benacre Hall - - - 44	23. 75. 139. 146. 156. 202,	Langley Farm - - - 479
Bicton - - - 484. 608	203. 209. 263. 293. 295. 305.	Langley Hall - - - 44
Billingbear Park - - - 672	318. 346. 347. 394. 477. 541.	Leeds Abbey - - - 327
Blackheath Park - - - 121	591. 595. 672.	Levens Hall - - - 663
Blagdon - - - 674	Royal, Bavaria - - - 674	Lime Grove - - - 566
Blaize Castle - - - 337	Surrey Zoological - - 361	Litchurch Villa - - - 101
Blickling - - - 331	Allen, Hon. W. - - - 66	Littlecote - - - 331
Botanic Gardens : -	Anderson, David, Esq. 271	Longleat - - - 331
Bartram's - - - 180	Balfour, James, Esq. - 271	Maslough Castle - - - 207
Bath - - - 43	Beacon, Rev. Frederick 476	Margam - - - 498
Belfast - - 363. 484. 567	Brignold, S., Esq. - 600	Melville House - - - 275
Birmingham - 19. 102. 150.	Chalmers, Mrs. - - - 410	Merevale Hall - - - 224
- - - 501. 546	Child, —, Esq. - - - 470	Moseley Hall - - - 599
Calcutta - - - 608	Crookshanks, Hon. G. - 66	Newington Lodge - - - 270
Cambridge - - - 479	Dunn, Hon. J. H. - - - 66	Nurseries : -
Carlsruhe - - - 578	Fox, —, Esq. - - - 484	Adams's - - - 67
Chelsea - - - 110. 361	Friend, John, Esq. - 312	Albion (Stoke Newington)
Edinburgh - 175. 295. 608	Garnier, Rev. J. - - - 489	- - - 269
Gilbault's - - - 68	Goodenough, Asa, Esq. 69	Bagshot - - - 146
Glasgow - 20. 147. 294. 476	Gurney, Mrs. Jane - 600	Barrett's (Wakefield) - 299
Glasnevin - - - 476. 594	Hamilton, Peter, Esq. - 66	Belonge's - - - 67
Kew - 183. 184. 232. 365.	Harrison, Will., Esq. - 489	Berkhamstead - - - 45
505. 566. 586. 590. 601. 675	Hawley, Ira, Esq. - - - 67	Blinkbonny - - - 68
Leyden - - - 578	Hewitt, Rev. Augustus 480	Canterbury 44. 47. 209. 541
Liverpool - - - 361	Ives, F., Esq. - - - 600	Chandler's - - - 201
Munich - - - 578	Jarvis, W. B., Esq. - 67	Chester - - - 44
Newburgh - - 645. 658	Johnson, Mr. - - - 567	Clapton - - - 45. 238. 343
Regent's Park - 183. 232.	Markland, Hon. Geo. - 66	Clarendon (Jersey) - 174
321. 514. 605	M'Nab, Sir Allen Napier 65	Colvill's (King's Road) 126
Saharumpore - - - 4	Merry, R., Esq. - - - 600	Cullis's - - - 586
Sheffield - - - 59. 294	Molson, John, Esq. - 69	Durham Down - - - 486
St. Augustine - - - 662	Nesbitt, Mrs. Hamilton 502	Exeter - - - 310. 593
St. Petersburg - - 546	Penn, John, Esq. - - - 120	Fleming's - - - 67
Sloane Street - - - 26	Powell, Hon. Chief Jus-	Forest's (Kensington) - 240
Trinity College - 476. 546	tice - - - 67	- - - 609
Boultonbrook - - - 379	Robinson, Hon. Chief	Forres - - - 153
Bowood - - - 358. 419	Justice - - - 67	Fulham - 11. 47. 73. 363.
Bracondale - - - 610	Rogers, John, Esq. - 477	- - - 541
Bradley House - - - 585	Sacco, Dr. - - - 306	Hammersmith - 565. 675
Bramshill - - - 331	Strutt, Edward, Esq. - 121	Handsworth - - - 98
Brereton - - - 331	Strutt, George, Esq. - 121	Hooker's - - - 476
Bromley Hill - - 24. 45	Strutt, Jedediah, Esq. - 121.	Hope - - - 605
Burghley House - - - 331	- - - 126	Inverleith - - - 270
Bury Hill - - - 413	Sutor, —, Esq. - - - 65	Jeckell's - - - 67
Caen Wood - - - 566	Taylor, A. Esq. - - - 600	Kilmarnock - - - 97
Calderstone - - - 476	Unthank, C. W. Esq. - 600	Knight's Exotic - 147. 238.
Carclaw - 17. 23. 476. 549. 593	Vivian, John Henry - 477	268. 311. 346. 572
Castle Ashby - - - 331. 670	Warner, W. L., Esq. 601	Lavender Hill - - - 311
Castle Hill - - - 391	Wauchope, John, Esq. - 271	Leith Walk - - - 46
Castle Martyr - - - 611	Wells, Hon. Joseph - 66	Loddiges - - - 114. 201
Catton - - - 600	Willmore, John, Esq. - 149	Logan's - - - 67
Charlton House - - 342. 582	Winnett, Major - - - 65	Mackie's - - - 476. 548
Chatsworth - 163. 107. 180. 186.	Wise, Rev. H. - - - 411	Mansfield's - - - 67
203. 229. 275. 354. 377. 572	Zanoli, Baron - - - 98. 304	Mill End - - - 490
Claremont - - - 476. 581	Garnstone Park - - - 172	Milford - - - 37. 656
Closeburn - - - 302	Gosford House - - - 270	Montreal - - - 68
Cobham Hall - - - 331	Grove Hill - - - 502	Norbiton - - - 311
Coliseum - - - 586	Hafield - - - 419	Pine-Apple - - - 1. 343
Cosseley Hall 244. 254. 276. 388.	Hafton Gardens - - - 567	Ripon - - - 594
391. 393. 601	Hagley - - - 352	Rollison's - - - 501
Cowdray - - - 331	Hardwick - - - 331	Sawbridgeworth - 11. 47.
Croome Park - - - 44. 45	Harlaxton Manor - - - 329	100. 263. 541
Danby Cottage - - - 586	Harringay - - - 342. 584	Shepherd's - - - 68

Nurseries, <i>cont.</i>	Ripley Castle	-	-	269	Town Close	-	-	600
Southampton	Rolleston Hall	-	-	476	Trent Park	-	-	342
St. Helier (Jersey)	Rosemont	-	-	594	Trentham Hall	-	-	342. 580
Taunton	Rose Park	-	-	271	Valentines	-	-	311
Oakfield Lodge	Rossie Priory	-	-	252	Valley Field	-	-	402
Oak House	Scone Palace	-	-	250	Vine Cottage	-	-	129
Ochertyre House	Sketty Hall	-	-	476	Wardour Castle	-	-	586
Osberton	Somerford Hall	-	-	476	Warwick Castle	-	-	615
Owston	South Lodge, Enfield	-	-	328	Welbeck	-	101. 177. 399.	594
Pain's Hill	Spofforth	-	150. 235. 346.	476	Wemys Castle	-	-	271
Penllegare	Springfield	-	-	102. 616	Westworth House	-	-	185. 550
Penrice Castle	Stoke Edith Park	-	-	597	West Heath	-	-	583
Pitfour	Stoneham Park	-	-	476	Westwood	-	-	331
Pitmaston	Stow	-	46. 327.	588	Whitmore Lodge	-	-	145
Priory	Stratton Park	-	-	667	Woburn	-	143. 202. 295.	476
Radford Cottage	Studley Royal	-	-	384	Wollaton	-	-	331. 590
Rashton	Syon	-	48. 123. 131. 344.	590	Woodlands	-	-	582. 584
Ravingham Hall	Temple Newsham	-	-	331	Woodton Lodge	-	-	342. 579
Redleaf	Theobald's	-	-	587	Workshop Manor	-	-	477
Regent's Park	Thirlestaine Castle	-	-	567	Wortley Hall	-	-	105

LIST OF BOOKS REVIEWED OR NOTICED.

- Agardh's *Reценso Specierum Generis Pteridis*, 33.
- Annales des Sciences Physiques et Naturelles d'Agriculture, &c. de Lyon, 358.
- Appleby's Catalogue of Plants, 217
- Anon. A Hand-book for Cultivators of Fruit Trees, 263. 517.
- Anon. Annual Report of the Royal Cornwall Polytechnic Society, 95.
- Anon. Companion to the Almanack for 1840, 35.
- Anon. Design for laying out the Garden of the Royal Botanic Society of London, 605.
- Anon. Edinburgh Quarterly Journal of Agriculture, 213.
- Anon. Elements of Botany for Families and Schools, 32.
- Anon. Hints for the Use of Highland Tenants and Cottagers, 214.
- Anon. Journal of the English Agricultural Society, 169.
- Anon. London Architectural Precedents, 267.
- Anon. The British Almanack for 1840, 35.
- Anon. The Penny Magazine, 222.
- Anon. The Year-Book of Facts, 267.
- Anon. Transactions of the Horticultural Society of London, 346. 394. 467.
- Anon. Transactions of the Society of Arts, 298
- Anon. Transactions of the Imperial and Royal Agricultural Society of Vienna, 298.
- Anon. 'Twenty Years' Experience in Australia, 299.
- Anon. Regulations for the internal Administration of the Garden of the Horticultural Society of London, 318.
- Anon. Report of the Society for obtaining free Admission to the National Monuments, 563.
- Baines's Flora of Yorkshire, 660.
- Berlèze's Monographie du Genre *Camellia*, &c., 668.
- Brady's Visitor's Guide to Knowle, 35.
- Bridgeman's Florist's Guide, 560.
- Buist's American Flower-Garden Directory, 297.
- Burnett's Illustrations of Useful Plants, employed in Medicine, 297.
- Carter's Catalogue of Bulbs, 562.
- Clark's Method of Pruning and Training Standard Apple Trees, 263.
- Curtis's Botanical Magazine, 18. 145. 201. 292. 343. 545. 592.
- Daly's Revue Générale d'Architecture et des Travaux Publics, &c., 35.
- Davy's Agricultural Chemistry, 95.
- Davy's Architectural Precedents, 562.
- DeCandolle's Vegetable Organography, 163.
- De Lessert's Figures of select Plants from the Herbariums of Paris, 350.
- Donaldson's Baydon's Art of valuing Rents, &c., 94.
- Drummond and Sons' Catalogue of Implements, Seeds, Plants, &c., 562.
- Drummond's Letter to Thomas Phillips, Esq., R.A., on the Connexion between the Fine Arts and Religion, 561.
- Drysdale and Lawson's Catalogue of Seeds, &c., 562.
- Exposition de Fleurs, &c., de Lyon, 663.
- Francis's Grammar of Botany, 560.
- Grigor's Eastern Arboretum, 352. 600. 665.
- Hodges's Use of Pearson's Draining Plough, 35.
- Hooker's *Icones Plantarum*, 167.
- Hooker's Journal of Botany, 300.
- Jackson's Treatise on Agriculture and Dairy Husbandry, 669.
- Johnson and Shaw's Farmer's Almanack, 607. '1
- Johnson's, Louisa, Every Lady her own Flower-Gardener, 660.
- Johnson, On increasing the Depth of Soils, 216.
- Jones's Principles and Practice of Levelling, 267.
- Kittoe's Illustrations of Indian Architecture, 356.
- Knowles and Westcott's Floral Cabinet, 18. 145.
- Kollar's Treatise on Insects, 92.
- Lemaire's *Cactearum Genera nova, Species, &c.*, 32.
- Lewis's Illustrations and Description of Kilpeck Church, Herefordshire, 561.
- Lhotsky's Journey from Sydney to the Australian Alps, 217.
- Liebig's Organic Chemistry, 604.
- Lindley's Appendix to the Botanical Register, 94.
- Lindley's Botanical Register, 18. 145. 201. 292. 343. 545. 593.
- Lindley's Report on the Botanic Garden at Kew, 365.
- Lindley's Theory of Horticulture, 92. 155. 425.
- Link, Klotzch, and Otto's *Icones Plantarum rariorum Horti Regii Botanici Berolinensis*, 554.
- Loudon's Arboretum Britannicum, 11.
- Loudon's Edition of Repton's Landscape-Gardening, 262.
- Loudon's Suburban Gardener, 24.
- Loudon's, Mrs., Companion to the Ladies' Flower-Garden, 267.
- Loudon's, Mrs., Gardening for Ladies, 267. 350.
- Loudon's, Mrs., Ladies' Flower-Garden of Ornamental Annuals, 19. 262. 292.
- Loudon's, Mrs., Ladies' Flower-Garden of Ornamental Bulbous Plants, 263.
- Loudon's, Mrs., Magazine of Gardening, 607.
- Macgillivray's Manual of Botany, 560.
- Main's Forest Pruner, 517.
- Mallet's Experiments upon the Action of Sea and River Water, 34.
- Marnock's Floricultural Magazine, 603.
- Maund's Botanist, 18. 145. 292. 343. 545. 593.
- Maund's Botanic Garden, 18. 145. 292. 545.
- May's Catalogue of Plants, 605.
- Mörch's Catalogus Plantarum Horti Botanici Hafniensis, 34.
- Morgan's Religion and Crime, 606.

- Morton's Report on the present State of Whitfield Farm, 2 6.
 Mudie's Florist's Journal, 602.
 Mudie's Surveyor, Engineer, and Architect, 171.
 Mudie's Views of the Adaptations of Nature in the Vegetable Kingdom, 220.
 Newman's History of British Ferns, 163.
 Page's History and Guide for Drawing the Acanthus, 355.
 Parke's Report on Perkins's Patent Steam Boiler, 299.
 Pauls's Catalogue of Roses, 562.
 Paxton's Botanical Dictionary, 557.
 Paxton's Magazine of Botany, 13. 132. 145. 201. 292. 343. 545. 593.
 Perkins's Patent Apparatus for Warming and Ventilating Buildings, 266.
 Redfield's Remarks on Mr. Espy's Theory of Centripetal Storms, 35.
 Ricauti's Rustic Architecture, 355. 519. 561.
 Rivers's Catalogue of Trees and Shrubs, 10.
 Rivers's Descriptive Catalogue of Fruits, 263.
 Rivers's Rose Amateur's Guide, 298.
 Royle's Natural History of the Himalayan Mountains, 318.
 Sang's Catalogues of Flower Seeds, Geraniums, Fruit Trees, Seeds, and Implements, 93.
 Sayer's American Flower-Garden Companion, 559.
 Sayer's Treatise on the Culture of the Dahlia and Cactus, 559.
 Sheer's Kew and its Gardens, 297.
 Sproule's Treatise on Agriculture, 34.
 Taylor's Help to the Schoolmistress, 562.
 The Gardener's Annual Register, 607.
 Tim's Literary World, 266.
 Tollard's Traité des Végétaux qui composent l'Agriculture, &c., 663.
 Torrey and Gray's Flora of North America, 94.
 Traité de la Composition et de l'Ornement des Jardins, &c., 662.
 Vilmorin's Bon Jardinier, 296.
 Visiano's Origin and Antiquity of the Botanic Garden of Padua, 297.
 Vittadini's Description of the Eatable and Poisonous Sorts of Fungi common in Italy, 298.
 Walker's Gatherings from Grave-Yards, 95.
 Webb's Selection of rare Plants indigenous to Spain, 94. 297.

LIST OF CONTRIBUTORS.

- A. B., 152. A. G., 220. Alexander, James, 207.
 Allen, James, 48. Amicus, 268. 275. 300.
 Anderson, W., 110. 275. Appleby, T. 189. A Subscriber, 37. 568.
 Bainbridge, Rev. T., 23. B. C., 42. Beaton, D., 26. 129. 155. 229. 277. 326. 420. Berkeley, M. J., 258. 376. Billington, B. B., 269. Braithwaite, G. M., 231. Brewster, J., 388. Booth, W. B., 16. Brown, T. C., 36. 218. Brown, W., 224. 376. Brown, Hay, 597. Buist, George, 193.
 Cameron, David, 103. Clarke, John, 38. Clarke, W., 44. 45. C. M. B., 102. Conductor, 10. 37. 41. 42. 43. 45. 46. 47. 48. 73. 97. 100. 101. 102. 104. 110. 115. 120. 180. 184. 220. 223. 233. 268. 269. 270. 278. 280. 302. 303. 310. 312. 322. 325. 329. 358. 362. 375. 418. 514. 517. 519. 521. 564. 565. 566. 567. 569. 609. 616. 617. Cuthill, J. 90.
 D. B., 268. 272. Downing, A. J., 658. D. R., 48. Dunbar, W., 183. Duncan, John, 224.
 E., 326. E. B., 278. Elliott, G. M., 269.
 F., 326. Fenn, T., 44. Fish, John, 246. 383.
 Forsyth, Alexander, 103, 104. 153. 204. 230. 255. 259. Fowler, Benjamin, 324.
 Glenny, George, 16. Glendinning, R., 608. Gordon, Alexander, 63. 565. 660. Gordon, G., 1. Gordon, W., 609. Gorrie, Archibald, 610. Grigor, John, 153.
 Herbert, Hon. and Rev. W., 289. 290. 380. 381. H. L., 45. H. T., 43. Hutchinson, W., 389.
 Jennings, John, 389. J. J., 311. J., 174. J. B. W., 105. 173. 185. 302. 327. 377. 520. J. D., 37. J. L., 27. 31. 81. 111. 150. 259. 657. 670. J. M., 181. 222. 227. J. O. N., 104. J. P. W., 656. J. R., 273. 323. 361. Jukes, H. W., 384. J. W. D., 280.
 K. B. D., 115. Keene, W., 611. Kenbury, Charles, 313. Kidd, J., 252. Kirkwood, William, 40.
 Leclerc, L., 616. Lowndes, R., 672. L. P., 514. L. R., 376. Lymburn, R., 104. 210. 218. 326. 425. Lyons, John, 375.
 Main, J., 50. 517. Manetti, Giuseppe, 70. 99. 225. 241. 310. Masters, W., 209. M'Nab, J., 41. Mease, J., 231. Munro, J., 670.
 Nesfield, W. A., 49. N. M. T., 186. 640. N. T., 104. 110.
 Pamplin, W., junior, 311. Pearson, John, 48. P. N., 175. 272. Portland, Scott, 101. P. S., 514.
 Repton, John Adey, 615. Ricauti, S. J., 519. Robertson, Patrick, 567. Robison, Sir John, 117. 230. Rogers, John, 159. 196. 281. R. T., 89. Rutger, T., 566. R. W. F., 243.
 Sang, John, 190. Saeul, Amaziah, 390. Saunders, Bernard, 45. Scott, J., 37. Seymour, James, 83. 89. 91. 207. S. M., 303. Sowerby, J. D. C., 313. 517. Spencer, John, 358. 419. Surreyensis, 280. 568.
 Taylor, Samuel, 101. 224. 502. 567. Taunton, W. P., 609. T. B., 44. 311. T. C., 101. Thackeray, John, 154. Thompson, John, 43. Tongue, R., 672. T. R., 375. 376.
 Veitch, Henry, 113. 360. Veritas, 424. Vilmorin, 568. 672.
 W. A. M., 311. 312. 360. W., 59. 229. 257. 520. Wagner, F. E., 100. W. B., 180. Webster, J., 203. Weilbach, A., 108. W. H. 269. 598. W. H. W., 419. Wighton, J., 244. 252. 276. 385. 391. 393. Wilmot, J., 123. Wilds, W., 39. Wilson, William, 674. Wright, James, 312. W. T., 38.

THE SUBURBAN HORTICULTURIST;

Being an Attempt to explain the whole Science and Art of Horticulture to those who have hitherto been without experience or practice. By J. C. LONDON.

To be published monthly, and completed in twelve Numbers. No. 1., Price 1s. will appear on the 1st of January, 1841.

THE LADIES' MAGAZINE OF GARDENING,

With coloured Plates of new or rare Flowers, and with numerous woodcuts.

No. 1., Price 1s. 6d., will be published on the 1st of January next. To be continued monthly. Publisher, W. SMITH, 113. Fleet Street. Editor, Mrs. LONDON.

THE
GARDENER'S MAGAZINE,
JANUARY, 1840.

ORIGINAL COMMUNICATIONS.

ART. I. *Report on the new Species and Varieties of Hardy Trees and Shrubs raised in the Horticultural Society's Gardens since the last Report, made in October, 1838, and published in the "Gardener's Magazine,"* vol. xiv. p. 581. Drawn up for the "Gardener's Magazine" by Mr. GORDON, Foreman of the Arboretum, by Permission of the Council of the Horticultural Society.

RANUNCULA CÆÆ. — *Clématis gràta* Wall. This species was raised from Himalayan seeds presented to the Society by Dr. Royle; it is quite hardy, and a free grower, flowering in October. The flowers are small, like those of *C. virginiana*, to which it seems nearly related, but with much smaller leaves. It was received by the Society under the name of *C. nepalensis*, but upon flowering it proved to be *C. gràta* of Dr. Wallich; *C. nepalensis* being one of those species which, like *C. montana* Wall., flower in May. It is not yet introduced.

Clématis [cirrhòsa] polymórpha Lodd. This is, I think, only a large, but very distinct, variety of *Clématis calycina* Ait., with large spotted flowers, and foliage double the size. It is probably the true *Clématis baleárica* of Persoon, as one of the plants in the Society's collection was received from the Hon. W. Fox Strangways as the true *C. baleárica*. The specific name *baleárica* is often applied to *C. flámmula rotundifòlia*, which is the same as *C. fràgrans*, the subevergreen variety of *C. flámmula*.

Clématis Hendersònnii Chandler. This beautiful hardy creeper should be in every collection, and trained on every suburban cottage, for it is one of the most ornamental of the genus, with large bright purple flowers, which are produced in profusion from June to September. It appears as if it had been raised between *C. integrifòlia* and *C. Viticèlla*, but it is decidedly ligneous. It was raised by Mr. J. A. Henderson, F.H.S., Pine-apple Place. The plants in the Society's collection were presented by Messrs. Chandler and Mr. Henderson.

Clématis [campaniflòra] parvisflòra Dec. The Society is indebted to the late M. Fischer of Göttingen for this ? species. It is very nearly related to *C. campaniflòra* *Arb. Brit.* p. 242.,

but has flowers only one half the size, and the plant is of slenderer growth; but the colour of the flowers and the plant in other respects is nearly the same, and it is probably only a variety of *C. campaniflora*.

The following prove to be the same as *Clématis campaniflora* *Arb. Brit.*, viz. *C. viornoides* *Schrader* and *C. Viticélla baccata* *Dec.*

BERBERA`CÆ. — *Bérberis* [?] *ibérica*] *glauca* *Booth*. This is a distinct but rather slender plant, with small but very glaucous leaves, and is nearly related to *B. ibérica*. It was received from Messrs. Booth of Hamburg, but it is in other collections under the false name of *B. ilicifolia*; but the true *B. ilicifolia* of Forst. is the same as the *B. heterophylla* of Juss., a plant found near the Straits of Magellan, while the present plant is probably from the Altai or Caucasus.

Bérberis caroliniana *Nutt.* This is only a variety of *B. canadensis* (or rather of *B. vulgàris*), with long narrow leaves; and, as a variety of the common berberry, is very distinct and rather singular.

Bérberis [*vulgàris*] *provincialis* *Schrader*. This ? species has dark brown shoots, with few spines, red fruit, and rather shining leaves, which are retained longer than on most of the varieties of *B. vulgàris*. It seems as if it were intermediate between *B. vulgàris* and *B. sinensis*, and it is probably only a rather distinct variety of *B. vulgàris*. The plant was received from the late M. Fischer of Göttingen, as the true *B. provincialis*; that generally sold in nurseries for *B. provincialis* not being different from *B. vulgàris*.

Bérberis [*vulgàris*] *lucida* *Schrader*. This is only the common *Bérberis vulgàris*, with rather larger and brighter leaves.

Bérberis [*vulgàris*] *emarginata* *Willd.*, *Arb. Brt.* p. 303. This is only a rather strong-growing variety of *B. vulgàris*, but not very distinct. It was received from M. Fischer of Göttingen.

Bérberis [*vulgàris*] *spatulata* *Schrader*. This also is only a very slight variety of *B. vulgàris*.

ACERA`CÆ. — *A`cer* [*eriocarpa*] *Pàvia* *Booth*. This is only a variety of *A. eriocarpa*, with the leaves a little more divided, and the upper surface wrinkled like some of the pavias, which I suppose induced Messrs. Booth to give this variety of (Sir Charles Wager's) maple so absurd a name.

A`cer [*campêtre*] *taurica* *Dr. Fischer*. This seems to be one of the endless varieties of *A`cer campêtre*, with less divided and larger leaves, but decidedly only a variety of the common maple.

RHAMNA`CÆ. — *Ceanòthus thyrsiflorus* *Lindl.* This handsome species is very distinct from *C. azureus*. It has much smaller and rounder leaves, and rather flat panicles of bright blue flowers. It is the *C. ovatus cyaneus* of the Continental col-

lections, and was presented to the Society by Messrs. Booth and Messrs. Baumann.

LEGUMINOSÆ.—*Sophora heptaphylla* Bentham. A small-flowering species, probably from China, which has proved quite hardy, but of little beauty. It flowers in October.

Genista tinctoria flore pleno. This pretty double-flowered variety of the common dyer's broom was received from Messrs. Young of Epsom.

Eysenhardtia amorphoides Lindl., Bot. Reg. Miscell. 55. 1839, H. et B., vol. vi. t. 592., Don's Mill. vol. ii. p. 234. A very curious and ornamental plant raised from Mexican seeds, presented to the Society by G. F. Dickson, Esq., F.H.S. It is hardy, and resembles a small-leaved species of *Amorpha*, with numerous spikes of small flowers.

ROSA CÆ.—*Spiræa adiantifolia* is the same as *S. vacciniifolia* Don.

Spiræa laxiflora Lindl., Bot. Reg. Miscell. 89. 1839. This species very much resembles in foliage and habit *S. vacciniifolia* Dec., but has rather large loose panicles of white flowers. It was raised in the garden of the Society, from seeds, presented by the Hon. East India Company, from the North of India.

Spiræa cuneifolia Wall., Bot. Reg. Miscell. 87. 1839. This is the same as those sold in the nurseries about London under the following names:—*S. argentea*, *S. nutans*, and *S. canescens*. The first name (*argentea*) belongs to a plant from New Granada, H. et B. vol. vi. t. 562., not yet introduced; the others are names applied by different authors. *S. cuneifolia* is quite hardy, and is a native of the North of India.

Spiræa Lindleyana Wall. This fine species belongs to the section *Sorbària*, with large pinnate and finely serrated leaves. It is very hardy, and a great addition to this beautiful family of shrubs. Raised in the garden of the Society, from seeds received from Dr. Royle.

Cratægus [spathulata] georgica Lodd. (not of Douglas). This is certainly distinct from *C. microcarpa* Lindl., which is *C. spathulata* Arb. Brit., but nothing more than a variety of that species, with the leaves five-lobed, on longer footstalks, and rather smaller, while those of *C. microcarpa* are mostly three-lobed, and broader. *C. microcarpa* and this variety were the only *Cratægi* killed in the Society's very extensive collection by the winter of 1837–8.

Cratægus pectinata of some collections is the same as *C. coccinea corallina* Arb. Brit.

Cratægus fusca Jacq. Plants were raised from seeds received from Baron Jacquin, under the above name; they have large prominent buds and cut leaves, like *C. nigra* or *C. purpurea*.

Cotoneaster [(r) buxifolia] marginata Lindl. This pretty plant

comes nearest to *C. buxifolia*, with rather larger leaves, which are covered thickly on the under side and margin with a dense white tomentum. It was raised in the garden from seeds, sent to the Society by Dr. Falconer, from the Saharanpore Botanic Garden.

Cotoneaster denticulata H. et B. vol. vi. t. 556. This distinct species was raised from seeds collected by M. Hartweg, the Society's collector in Mexico; and, as the Society has distributed a large quantity of the seeds to the Fellows of the Society, it will soon become common. It is probably not so hardy as the other species of *Cotoneaster*, not one of which was killed by the winter of 1837-8 in the Society's garden.

PHILADELPHA`CEÆ. — *Deutzia corymbosa* Lindl., Bot. Reg. Miscell. No. 49. 1839. This I mentioned in my report of last year (Vol. XIV. p. 582.) under the name of *D. canescens Sieboldt*; but, when the plants flowered in the Society's collection, they proved to be the same as *D. corymbosa Royle*, figured in *Royle's Illustrations*, plate 46. fig. 2.

GROSSULA`CEÆ. — *Ribes* [*Grossularia*] *himalayanum* Royle. This was raised from seeds presented to the Society by Dr. Royle, and seems hardly different from the *R. Grossularia*.

SAXIFRA`GEÆ. — *Hydrangea alissima* Wall. This curious species was raised in the garden of the Society, from seeds sent by Dr. Falconer, the superintendent of the Hon. E. I. Comp. Botanic Garden at Saharanpore; but the plants are too small at present for me to say more than to record its introduction.

CAPRIFOLIA`CEÆ & LONICE`REÆ. — *Lonicea Ledebourii* Eschsch. This very distinct species comes nearest to the *L. involucrata*, but is quite distinct; it has much smaller leaves, and yellower flowers. The plant was received from Messrs. Booth.

Caprifolium (sempervirens) Brownii. This is a fine variety of the trumpet honeysuckle raised by Messrs. Brown of Slough, and which, I think, should bear their name, as indicating the place of its origin. It has larger and rather brighter flowers than the common one, and, as a variety, is a great acquisition.

ERICA`CEÆ. — *Andromeda Drummondii?* Hooker. This distinct species was given to the Society by Mr. J. Cunningham of Edinburgh. It is rather a slender-growing plant, with the young leaves covered, as well as the young shoots, with a scurf like those of an *Elæagnus*.

Arbutus speciosa Dickson. This beautiful species has long, lanceolate, finely serrated leaves, glaucous on the under side, and bright green on the upper. It will probably form a large bush, or small tree. It was raised in the garden of the Society, from seeds, presented by G. F. Dickson, Esq. F.H.S., collected in Mexico.

Pernettya Cummingii Lodd. This is nearly related to *P.*

mucronàta, but differs from that species in having larger, less serrated, and more ovate leaves. It was given to the Society by Messrs. Loddiges.

SOLANA`CEÆ.—*Lycium rigidum* Booth. This very distinct species has rather long linear leaves and stiff shoots, resembling *L. ãfrum* in having its glaucous appearance. It is probably a native of China or the North of India, and was presented to the Society by Messrs. Booth of Hamburg.

ELÆAGNA`CEÆ.—*Elæagnus parvifolia* Royle. This was raised from seeds for which the Society is indebted to Dr. Royle, who has been the means of introducing so many fine plants from the North of India. It is very distinct, with small round leaves, and said to be quite hardy. There is a figure of it in Dr. Royle's beautiful *Illustrations of the Flora of Northern India*, t. 81. fig. 1.

Elæagnus [hortensis] songárica Fisch. This is only a variety of *E. hortensis*. It was received from Dr. Fischer.

ULMA`CEÆ.—*Plánera ulmifolia* Baumann, *Plánera Gmèlini* Arb. Brit. This seems only a dwarf variety of *P. Richárdii*, but rather distinct; at all events it is as distinct as many of the kinds of *Ulmus* which are recorded in books as distinct species. It seems to be the same as *P. aquática*, which is one of the synonymes of *P. Gmèlini* in *Arb. Brit.*

BETULA`CEÆ.—*Philippodéndron betuloides*. This is the *Bétula bélla* of Messrs. Booth, and of other Continental collections, and is the plant which so much noise was made about at Paris two years ago, "it being then named to compliment their citizen king," and having there just flowered, for the first time, I believe, in Europe. It is also known under the name of the New Zealand Birch, but the plant is not hardy, being destroyed by a few degrees of frost.

CORYLA`CEÆ.—*Quercus falkenbergénsis* Booth, Arb. Brit. vol. iii. p. 1926. This appears to be only one of the varieties of *Q. sessiliflora*, with rather narrower leaves; and, like some of the other varieties it retains its leaves longer, and in mild winters would no doubt become subevergreen. This is one of the so-called distinct species introduced to the Woburn collection about two years back. The plant in the Society's collection was presented by Messrs. Booth.

Cárpinus Carpinizza Jacquin. This is rather a distinct and curious spreading plant, resembling *C. Bétulus*, but with the leaves more pointed, and numerous small shoots; and is said to be better adapted for making hedges than the common hornbeam, and particularly dwarf ones. It was received from Dr. Fischer and Baron Jacquin.

TAXA`CEÆ.—*Tárus nucífera* Pers. This plant has proved perfectly hardy, and should be in every choice collection of hardy

trees and shrubs. It certainly appears more like a species of *Taxodium* than of *Taxus*.

CONIFERÆ.—*Pinus Gerardiana* *Arb. Brit.* p. 2254. Leaves 3 in a sheath. The seeds from which the Neoza pine was raised in the garden of Society, and for the first time true, were received from His Excellency Lord Auckland, who transmitted them overland to Dr. Lindley; he being aware, before he left England, that all the plants sold by the nurserymen, or raised by private individuals, under the above names, were nothing more than *P. longifolia*. The young plants are very robust, and, like those of *Abies Smithiana*, the points of the young plants recurve towards the ground, a thing I never observed before in any of the true pines. This species is quite hardy.

Pinus Teocôte *Arb. Brit.* p. 2266. Leaves 3 in a sheath. A large quantity of cones of this species, received from M. Hartweg, were distributed by the Society. It is a very distinct 3-leaved species, with very small cones, remarkably like those of the *P. sylvestris*. The drawing of the cone in the *Arb. Brit.* is too large, and is probably that of *P. leiophylla*. It is from the Ocotillo, and grows from 40 ft. to 50 ft. high. The seeds have vegetated freely.

Pinus patula *Arb. Brit.* p. 2267. Leaves 3 in a sheath. This is another pine, of which a large quantity of the seeds were distributed by the Society. It is a 3-leaved species, with the cones growing in clusters of six or eight; they are very hard, of a yellowish brown colour, mostly horn-shaped, and from 3 to 4 in. long. It is from Guajoloté, growing 60 or 70 feet high. The seeds have vegetated freely.

Pinus Hartwegii *Lindl. Bot. Reg. Miscel.* 95. 1837. Leaves 4—5 in a sheath. This very handsome pine was collected by M. Hartweg for the Society, and in compliment to him it has been named by Dr. Lindley. It is very curious in having the leaves mostly four in a sheath, but sometimes five. The cones are 4 in. long, slightly curved, tapering to a point, and of a dark brown colour, with the scales nearly flat. M. Hartweg sent it from the Campanario, where he found it a tree 40 or 50 feet high, and beginning to appear where the oyamel, or *Abies religiosa*, ceases to grow, about 9000 ft. above the sea, and hence it will prove hardy. The seeds have been distributed largely, and have vegetated tolerably well.

Pinus Devoniana *Lindl., Bot. Reg. Miscel.* 96. 1809. Leaves 5 in a sheath. This noble species of pine has the leaves five in a sheath, and nearly a foot long. The cones are about 10 in. long, 3½ in. broad at the base, and tapering to a blunt point, with the scales nearly flat. It is the "Pino blanco," or "Pino real" of the Mexicans, and was raised in the garden of the Society from seeds collected by M. Hartweg, who describes it

as a hardy tree from 60 ft. to 80 ft. high, found on the Ocotillo, between Real del Monte and Regla. Dr. Lindley has given it the above name, in compliment to His Grace the Duke of Devonshire, P.H.S. The seeds have vegetated freely.

Pinus Russelliana Lindl., Botanical Reg. Miscel. 97. 1839. Leaves 5 in a sheath. This fine pine has the leaves five in a sheath, and rather slender. The cones are about 8 in. long, 2 in. broad at the base, and terminating in a point, with the scales elevated into a small pyramid. It was found by M. Hartweg on the road from San Pedro to San Pablo, and by him transmitted to the Society, and the seeds have been largely distributed to the Fellows of the Society. Dr. Lindley has named it in compliment to the late Duke of Bedford. The seeds have grown freely.

Pinus macrophylla Lindl., Bot. Reg. Miscel. 98. 1839. Leaves 5 in a sheath. This splendid pine seems to be very scarce, as M. Hartweg only found one small tree. The leaves on the specimens sent home are in fives, 14 or 15 inches long, very robust, and resembling those of the pinaster. The cones are about 6 in. long, and 3 in. broad at the base, tapering to a point; the scales are strongly hooked backwards, like those of *Pinus Coulteri*, and are very hard. The seeds have grown remarkably well.

Pinus Pseudo-Strobilus Lindl., Bot. Reg. Miscel. 99. 1839. Leaves 5 in a sheath. This is another of M. Hartweg's very valuable new pines, with the leaves in fives, about 6 in. long, glaucous, and very slender. The cones are about 5 in. long, pointed, and curved, with the scales nearly flat. It is very common at Anganguco, about 8000 ft. above the sea, and no doubt will prove quite capable of enduring even such severe winters as that of 1837-8. The seeds have grown well.

Pinus apulcensis Lindl., Bot. Reg. Miscel. 100. 1839. Leaves 5 in a sheath. This very distinct species has the leaves in fives, much shorter than any of the preceding, and very glaucous. The cones are also much smaller, being rather larger than a hen's egg; they are ovate, covered closely with pyramidal elevations, which are sometimes prolonged into a hook, particularly those nearest the base and point. M. Hartweg found it growing 50 ft. high in the ravines near Apulco. (*Don*, in the last edition of *Sweet's Hort. Brit.*, has called this *P. acapulcensis*, but probably by mistake.)

Pinus oocarpa Schiede, Bot. Reg. Miscel. 23. 1839, Gard. Mag. vol. xv. p. 237. fig. 44. Leaves 5 in a sheath. This species has the leaves about 8 or 10 inches long, very slender, and five in a sheath. The cones are egg-shaped (as the name implies), very hard, above the middle size, and the scales slightly elevated and very smooth, having the appearance of being varnished. The cones are mostly solitary. It was found by M. Hartweg, near

the Volcano of Jorulla, forming a tree from 30 ft. to 40 ft. high; and Dr. Lindley thinks that it is one of the less hardy species. The seeds have vegetated freely.

Pinus Llaveana Schiede, Arb. Brit. p. 2267., and Gard. Mag. vol. xv. p. 128. fig. 23. Leaves 5 in a sheath. M. Hartweg has sent to the Society a large quantity of seeds of this species. The seeds are very large, and he says they are sold in the markets of Mexico as those of the stone pine in the South of Europe. The seeds are tolerably good, and have vegetated. This species grows from 15 ft. to 20 ft. high on the Cardonal, near Zimapan. You mentioned in Vol. XIV. p. 530. that Messrs. Low had raised a large number of plants of this species from imported seeds; but this is not the case, as I called there a short time ago, and, on examining their young Mexican pines, I found those which were raised were probably *P. Teocôte*, or *leiophýlla*, or perhaps a new species, with very small cones. [The information was given to us; we did not see the young plants.]

Pinus Montezimæ Arb. Brit. p. 2272. Leaves 5 in a sheath. This is another of M. Hartweg's large collection of Mexican pines, with five leaves in a sheath, and the cones very like, but about double the size of, those of *P. Hartwegii*. The reduced figure of the cone, fig. 2184. of the Arb. Brit., is very good, but fig. 2185. is doubtful. The tree grows from 40 ft. to 50 ft. high, on the road to the Sumate. The seeds have grown freely.

Pinus leiophýlla Schiede, Arb. Brit. p. 2273. Leaves in a sheath. This is another of M. Hartweg's collection of Mexican pines, with very small cones and long slender leaves. It is the "Ocote chino" of the Mexicans, and a most valuable timber tree, growing from 60 ft. to 100 ft. high, and the timber is so hard as to resist the carpenter's plane. Its chief range is about 7000 ft. above the level of the sea, on the mountains of Anganguco. It is most probably very different from the *P. leiophýlla* of Mr. Lambert, of which there are plants at Dropmore; but, as there has been a large quantity of good cones sent home by M. Hartweg, and distributed by the Society, it will soon become common in collections, by which it will be seen whether or not it is distinct. The seeds have vegetated freely.

Pinus Kesiya Royle. This species was raised from seeds presented to the Society by Dr. Royle, F.H.S. The cones resemble those of *P. insignis*, but they are not near so large, much flatter, and the scales not so prominent. It is very distinct in the cone from any previously sent from India.

Pinus pérsica Strangways, Gard. Mag. vol. xv. p. 130. This was raised from seeds presented to the Society by the Hon. W. F. Strangways. The young plants seem very like those of *P. halepensis* or *marítima*, but the cone is that of *P. Pináster*, with the seeds particularly spotted. The seeds have vegetated particularly well.

Pinus Hartwègii, *P. Devoniàna*, *P. Russelliàna*, *P. macrophýlla*, *P. Pseùdo-Stròbus*, and *P. apulcènsis* being entirely new species, are fully, both botanically and otherwise, described by Dr. Lindley, in the *Botanical Register* for August, 1839, p. 62. [By permission of the council of the Horticultural Society, we have had drawings taken of all the above specimens; and, as soon as they are engraved we shall publish them in an article supplementary to our *Arboretum Britannicum*, similar to that given in our preceding Volume, p. 118. and 236.]

Abies orientàlis Gard. Mag. vol. xv. p. 225. This is a very pretty and rather slender dwarf spruce, very like some of the varieties of the *Abies álba*, or white American spruce, but decidedly not a variety of the common spruce, as supposed by some. The Society received a plant about four years back from Dr. Fischer, and also some seeds from the Hon. W. F. Strangways, and lately a plant of the true *A. orientàlis* from Mr. Joseph Knight, F.H.S., all of which, I think, proves that it is only a variety of, or a nearly related species to, the white American spruce, and not to the common spruce.

Picea religìosa H. et B., Arb. Brit. p. 2349. The seeds of this beautiful fir, the pride of the Mexicans, have at last been introduced by M. Hartweg, who transmitted to the Society a large quantity of the cones, and it will now soon become common in all good collections. The leaves are, according to the specimens sent along with the seeds, about the size and shape of those of *A. Douglàssi*; but rather glaucous on the under side. The cones are about the size and shape of those of the cedar of Lebanon [whence we conclude it to be a *Picea*, not an *Abies*], but longer. It is the oyamel fir of the Mexicans, and is used for adorning their churches on the days of their saints, and hence the name. It was found by M. Hartweg on the mountains of Anganguco, at an elevation of 8000 or 9000 feet, attaining an immense size, 5 or 6 feet in diameter, and about 150 ft. high. He says it will prove quite hardy, and a very valuable timber tree. The seeds have grown tolerably well.

Picea Pinsàpo, Gard. Mag. vol. xv. p. 109. 187. 238. and 339. This, I think, is very nearly, if not identically, the same as *A. cephalónica*. It was first sent to the Society in the autumn of 1837, by Professor DeCandolle, as the Mount Atlas cedar or *P. Pinsàpo*; and last year by Mons. Vilmorin of Paris, as *Abies Pinsàpo*. I have raised some hundreds of both *A. cephalónica* and *Pinsàpo*, and I cannot see any distinction.

CUPRESSINÆÆ. — *Thuja Wareàna* Booth Cat. This plant seems not distinct from *T. orientàlis tatàrica* Arb. Brit. vol. iv. p. 2459. It was received from the Messrs. Booth.

Cuprèssus thurífera Bot Reg. Miscel. 101. 1839. The seeds from which this species was raised in the garden of the Society

were sent by M. Hartweg, who found it growing near Anganguco and Tlalpujahua, forming a tree 50 or 60 feet high.

Juniperus taúrica. The plants of this variety were raised from seeds presented by the Hon. W. F. Strangways, and seem tolerably distinct, but certainly nothing more than a variety of *J. Oxýcedrus Arb. Brit.* vol. iv. p. 2494. ; and, I think, should be named *J. Oxýcedrus taúrica*, rather than elevated to the rank of a species. May it not be *J. drupácea*?

Juniperus squamòsa Wall. This distinct species was raised from Indian seeds three or four years back, in the garden of the Society, and is a dwarf trailing robust species, resembling in habit *J. nàna*, but with the sharp-pointed leaves of the *J. comùnis*. It is perfectly hardy, and easily propagated by cuttings.

Juniperus daúrica. All the plants received at the garden, both from Messrs. Booth and others, have proved to be identically the same as *J. nàna*.

Juniperus tetragòna Bot. Reg. Miscel. No. 102. 1839, Gard. Mag. vol. xv. p. 242. This beautiful dwarf juniper was raised from seeds transmitted to the Society by M. Hartweg, who found it on his road from Real del Monte to Chico. It has quadrangular branches and small glaucous berries, and grows 4 or 5 feet high.

Juniperus fláccida Bot. Reg. Miscel. No. 103. 1839, Gard. Mag. vol. xv. p. 241. The seeds from which this was raised were transmitted to the Society by M. Hartweg, who found it growing in the neighbourhood of Regla. It forms a small tree from 15 ft. to 20 ft. high, with weeping branches, and glaucous fruit as large as a hazel nut.

SMILACEÆ. — *Smilax maculàta* Royle. This species has rather small, spotted, but very much pointed, leaves. It was raised from seeds, sent to the Society by Dr. Falconer, from the North of India.

There are still four or five other new species of *Pinus* in the garden of the Society, two of which are Mexican, and one from the mountains of Honduras ; but, having no names with the seeds, I refrain from saying more about them until another season.

Horticultural Society's Garden, Nov. 24. 1839.

ART. II. Notice of the Reception, by Nurserymen, of a Proposal to name Trees and Shrubs in their Collections ; with an Examination of a " Popular Catalogue of Trees and Shrubs," published by Mr. Rivers, Jun. By the CONDUCTOR.

[THE following article appeared in the *Gardeners' Gazette* of November 30th, with the exception of some additional matter here inserted.]

IN our preceding Volume (p. 517.) we offered to lend our assistance in naming collections of trees and shrubs in public gardens and nurseries, our

object being, as there stated, to second the influence of the *Arboretum Britannicum*, in introducing a correct and uniform nomenclature. As it may be interesting to some of our readers to hear how these "Proposals" have been received by nurserymen, we shall here state the general result up to this time.

The only London nursery establishment that has accepted our proposals is that of Messrs. Whitley and Osborn of Fulham; and we have accordingly examined the principal genera of trees and shrubs in their nursery, and a catalogue of these, with the same names as in the *Arboretum Britannicum*, is now printing, and will very shortly make its appearance. It is but justice to Messrs. Whitley and Osborn to state that, before they heard of our proposal, they had carefully compared their plants with the figures in the *Arboretum Britannicum*, as well as with the living specimens in the Horticultural Society's garden, so that in the genera *Acer*, *Cratægus*, *Pyrus*, &c., we found scarcely a single error. On the whole, being well acquainted with the nomenclature used in all the nurseries in the neighbourhood of London, we can confidently state that the nomenclature of the Fulham Nursery is by far the most correct.

With respect to the country nurserymen, several have corresponded with us on the subject of our "Proposal." One or two intend to have their collections completed from the Fulham Nursery, and to print catalogues with the nomenclature of the *Arboretum Britannicum*; others have sent up specimens to be named, and some few have sent for copies of the *Arboretum*, in order to ascertain the correct names of those trees and shrubs which they already have.

One or two nurserymen, both in town and country, have published short catalogues of their trees and shrubs without any authorities for the names; but of these nurserymen and their catalogues, we shall, with one exception, take no notice, because we can on no account approve or recommend them. The exception we allude to is Mr. Rivers, junior, of Sawbridgeworth, who has just printed what he calls *A Popular Catalogue of Trees and Shrubs*, which, in so far as it may obtain circulation, will have a tendency to defeat all the objects which we have had in view in publishing the *Arboretum Britannicum*. In Mr. Rivers's catalogue no distinction whatever is made between species and varieties, and no authorities are given for the names; so that, in point of real information, it is not a whit in advance of the nurserymen's catalogues of the last century. But, that we may not make any assertion respecting this catalogue, without proving what we say to be correct, we shall proceed to examine it; and, in order to give the reader Mr. Rivers's reasons for publishing it, we shall commence with the following quotation from his first page:—

"In the following catalogue, the name by which the different families of plants is best known is given first in the column.

"The genus under which they are arranged in Loudon's *Arboretum Britannicum* is in a parenthesis to the right; and when different from that under which they are arranged here, it is given and marked 'A. B.'

"Owing to the numerous changes that have taken place in the nomenclature of plants lately, these references have become quite necessary. Those beautiful shrubs well known as *Berberis fascicularis*, *Berberis Aquifolium*, &c. &c., are now *Mahonias*; and cases like this are very numerous, of plants, after being cultivated for many years, and having become well known under their first Latin name, being at once transferred by botanists to some fresh genus, much to the inconvenience of cultivators. Thus, that pretty evergreen, *Cratægus glauca*, is now *Stranvæsia glaucescens*; and the confusion in the genera and species of *Cratægus*, *Pyrus*, *Amelanchier*, *Mespilus*, &c., &c., is boundless. It may serve to illustrate how far this rage for change extends, when it is stated that the well-known genus *Ribes* is now divided by the Continental botanists into seven distinct genera, viz. *Adenobotrya*, *Calobotrya* (under which is placed *Ribes malvaceum*), *Chrysobotrya* (which includes

Ribes aureum), Coreosma, Grossularia, Rebes, and Robsonia: under the last is ranged our Ribes speciosum. The confusion arising from this incessant change has so inconvenienced many genuine lovers of hardy trees and shrubs, persons who love their gardens, but have not leisure to refer to botanical works, that I have been induced to make this first attempt to form a Popular Catalogue, with a few leading descriptions and directions for culture."

The trite observations against changes of names contained in this most illogical paragraph only show that Mr. Rivers belongs to the stationary school; but granting, for argument's sake, that the confusion exists to which he alludes, what has his "Popular Catalogue" to do with it?

"The confusion arising from this incessant change," he says, "has so inconvenienced many genuine lovers of hardy trees and shrubs, persons who love their gardens, but have not leisure to refer to botanical works, that I have been induced to make this first attempt to form a Popular Catalogue."

From this it is presumed, we are to understand, that the "Popular Catalogue" is to lessen "the confusion" proceeding from "incessant change," and to supply what could only before be obtained by "referring to botanical works." Now, to do this, we should think the first object would be, to endeavour to assign distinct names to distinct things; and, consequently, as species are more distinct than varieties, that they would have been named in such a manner as to show that they were species. This is always done in those botanical works to which, we presume, Mr. Rivers refers; and, in addition to this, the authorities for the names are always given. Instead of doing this, however, Mr. Rivers has not only confounded species and varieties, but he has introduced many of the latter hardly worth keeping distinct. Let us take for example the very first genus in his catalogue, which is given as under:—

" ACACIA (ROBINIA)

1 amorphæfolia.	13 macrophylla, or grandiflora.
2 crispa.	14 microphylla.
3 dubia.	15 pendula.
4 echinata.	16 procera.
5 floribunda.	17 pyramidalis.
6 formosissima.	18 sophoræfolia.
7 gracilis.	19 spectabilis.
8 heterophylla.	20 tortuosa.
9 hispida, or Rose Acacia.	21 tortuosa longifolia.
10 hispida major.	22 variegata.
11 inermis.	23 viscosa.
12 inermis rubra.	24 viscosa alba.

"No 9. to No. 13. inclusive are the only shrubs in this family: they form beautiful bushes, and also pretty standards for lawns: but the extremities of their shoots require pinching off in June; the wind will not then break them, and they will put forth a crop of autumnal flowers. All the other varieties are trees adapted to the background of shrub borders."

The first remark that we have to make is on the choice of the name Acacia for this genus. It is no doubt very generally given to it, as an English name: but, as there is another genus called by botanists *Acacia*, the second in Mr. Rivers's list, would it not have had a greater tendency to prevent that "confusion" which Mr. Rivers deplures, even if he did not choose to give the first its universally adopted botanical name, "Robinia," to have made choice of some of its other English names, as few plants have more popular synonyms; such as False Acacia, American Acacia, or Locust Tree. Besides this, there is a glaring absurdity in giving the Latin specific names to the popular English one; for no botanist, since the time of Linnæus, has ever called the Robinia, Acacia. With respect to the twenty-four kinds of Acacia enumerated in the above list, there are only five of them (8, 9, 11, 20, 23) that have any pretensions to be considered as species; the rest are varieties chiefly of *R. Pseud-Acacia*, but some of them, such as *inermis rubra*, *pyra-*

midàlis, tortuosa longifòlia, variegàta, &c., are so slightly marked, that, to a person wishing either to simplify or to select, they are not worth notice. Add to this, that some of the names, such as macrophýlla, péndula, and variegàta, belong alike to varieties of more than one species, as may be seen by referring to our *Arboretum Britannicum* or *Hortus Lignosus*.

Some persons who purchase a few trees and shrubs may be thought to care very little about their names, provided the plants are handsome; but this is by no means always the case, for the first question that is asked of the gardener, by any lady or gentleman who has been struck with the appearance of any plant, is, "What is its name?" But, supposing that some masters or mistresses care little about the names of their plants, is it nothing to prevent young gardeners from acquiring correct ideas of nomenclature?

If Mr. Rivers, instead of giving his list of Acacias, had enumerated the same plants in the following manner, his readers would have had something tangible to go upon; and, when they ordered plants, the nurserymen applied to would at least have been able to find out what was wanted: —

ROBÍNIA Pseùd-Acàcia	Ro. Pseùd-Ac.
amorphaefòlia <i>Link.</i>	grácilis
críspa <i>Dec.</i>	heterophýlla
microphýlla <i>Lod.</i>	pyramidàlis
procèra <i>Lod.</i>	dùbia <i>Fauc.</i>
sophoraefòlia <i>Lod.</i>	inérmis <i>Dec.</i>
spectàbilis <i>Dum.</i>	rùbra
tortuosa <i>Dec.</i>	híspida <i>L.</i>
longifòlia	màjor
echinàta <i>Lod.</i>	viscòsa <i>Vent.</i>
floribúnda	álba
formosíssima	

It appears, by this list, that no fewer than fourteen of Mr. Rivers's twenty-four kinds are varieties of the common Pseùd-Acàcia; and every one at all acquainted with that tree knows that the difference between the varieties is for the most part so very slight, as to be hardly worth keeping distinct. In short, any one may obtain as many varieties as he chooses, by sowing a bed with the seed, and selecting the most distinct of the seedlings. Is it not therefore likely to increase confusion, rather than to lessen it, to mix fourteen obscure varieties with five distinct species? If Mr. Rivers had even given all the varieties of Robínia Pseùd-Acàcia together, the confusion would have been less; but nothing can be worse than the manner in which he has jumbled them together in his list. After giving two varieties of Robínia Pseùd-Acàcia, he introduces a distinct species, R. dùbia; then he gives five varieties of R. Pseùd-Acàcia, next two species and their varieties (No. 9 to No. 13, inclusive); then he recurs to R. Pseùd-Acàcia, and gives four or five more varieties of that species (for R. péndula may belong to several species); next follows the species R. híspida; and, between that and the concluding species R. viscòsa, is introduced R. variegàta, which may belong to all or any of the species, there being rose acacias with variegated leaves, as well as common acacias. What is the confusion produced in botany by the changes of names alluded to by Mr. Rivers, compared with the confusion which this mode of confounding the names of trees and shrubs and varieties and species in nurserymen's catalogues will produce in nurseries, gentlemen's gardens, and in the minds of young gardeners? The changes introduced by botanists have at least the advancement of science for their object, but what object Mr. Rivers can have in view, we leave it for our readers to determine. For our own parts, we confess it baffles our penetration; as we cannot think so ill of him as to suppose that he wishes to induce his customers to purchase, as distinct species, plants differing in little else but the names he has thought proper to assign to them; and, as to the confusion which he deplures, instead of being lessened, it appears to us to be greatly increased.

All we know is, that the advancement of science is not the object, for science Mr. Rivers avowedly sets at defiance.

We have now, we trust, proved that Mr. Rivers has "confused" the genus *Robinia*, instead of throwing any light upon it; and we can assure our readers that he has done the same to an equal or greater extent with every genus introduced into his catalogue.

It would take too much time to review all Mr. Rivers's lists, but we shall say a few words on his manner of treating the genus *Cratægus*, because we have pointed out the confusion which exists in that genus in nurserymen's catalogues, in our article above referred to. Of this genus Mr. Rivers enumerates forty-two kinds; and, as in the case of *Acacia* and indeed, of all the other genera in his catalogue, he makes no distinction between species and varieties. Of his forty-two kinds no fewer than fourteen are varieties of the common hawthorn, some with Latin and others with English names; and these are interspersed throughout the list, so that they excite no suspicion of their being, with two or three exceptions, nearly all the same tree under different appellations. The following quotation will show the manner in which the English and Latin names of the different kinds of hawthorn are jumbled together:—

"Crimson or new scarlet, double pink, double white, Glastonbury, scarlet, upright (*stricta*), weeping, yellow-berried, *celsiana*, *laciniata*, *lutescens*, *pectinata*, *pterifolia*."

The whole of the genera in the catalogue are treated in the same manner, and English names and scientific names, species and varieties, are mixed up together in a manner that makes one laugh at the idea of the catalogue being intended to promote clearness and order. In short, if Mr. Rivers had entitled his catalogue "An Attempt to perpetuate the present Confusion which exists in the Nomenclature of Trees and Shrubs in Nurserymen's Catalogues, and to puzzle intending Purchasers," it would have given a much more correct idea of his performance than the title he has affixed to it. It is true that there is a class of men, to which Mr. Rivers seems to belong, who resolutely shut their minds against all improvements; descendants of those botanists who, in the days of Linnæus, reprobated the great Swede for his innovations and love of change, and of those politicians who, in the time of Elizabeth, fancied that the state would be ruined by Sir Hugh Myddelton's plan of bringing water to our houses by pipes, instead of water-carriers. Such men always have been, and always will be, behind their times; but mankind will not wait for them, and if they do not advance, they will be left behind. But, even supposing Mr. Rivers and his followers should adopt any particular set of names, new or old, that they may fancy, where would have been the harm of distinguishing between species and varieties? And, in short, in what respect would doing this have rendered the catalogue less "popular" or less "useful?"

We shall now attempt to show the effect Mr. Rivers's catalogue is likely to have on an intending purchaser. Suppose any person, having already a common *Robinia Pseud-Acacia* in his grounds, wishes to purchase another plant of the same genus, but, for the sake of variety, as different from the one he has as possible; at all events, a different species. How, we would ask, is he to do this from Mr. Rivers's catalogue? It is evident from the list, that the chances are two to one that he purchases, not a distinct species, but a variety of what he already has; or, supposing any person to wish to select half a dozen of different *Robinias*, surely it would be more desirable that he should have one of each species, than that he should have them all, or nearly all, varieties of one species, which, if he follows Mr. Rivers's list, it is extremely probable will be the case.

Even a worse case might, however, occur than this. Supposing a person "loving his garden," but not having "leisure to refer to botanical works," who had the common *Robinia*, and who, misled by Mr. Rivers's list into a belief that *Acacia* was the botanical name of the genus, were to order *Acacia*

péndula from his nurseryman, what would he get? Certainly not any kind of *Robínia*, but probably the *Acàcia* péndula of our *Hortus Britannicus*, an Australian shrub, which, so far from requiring the culture recommended by Mr. Rivers for his genus *Acàcia*, would, if planted out without protection, be probably killed by the first frost. If this be a means of lessening confusion, it is certainly rather difficult to discover in what manner it acts.

It now only remains for us to notice Mr. Rivers's intended attack on botanists for their "incessant changes," which he very inappropriately illustrates by Spach's division of the genus *Ribes*. Had Mr. Rivers been as thoroughly acquainted with the subject as he apparently wishes his readers to suppose him, he would have known that Spach's divisions have not been adopted even by "Continental botanists."

We might say much more on this subject, but we think we have proved that Mr. Rivers's catalogue, so far from lessening, is likely to increase the confusion that at present prevails respecting the names of trees and shrubs. The evil, however, great as it is, cannot be of long duration; for, from the rapidly increasing desire for the study of botany, and the equally rapidly increasing taste for arboriculture, the purchasers of trees and shrubs will soon know too much to be misled, in spite of all the efforts which those of the stationary school are making to retain them in ignorance.

We have not yet said anything respecting Mr. Rivers's "Directions for Culture," and we shall only notice the note to his genus *Acàcia*. He says the "trees are adapted to the background of shrub borders." Now this is a point which we dispute, both with reference to taste and to culture. A background to shrubs ought to be composed of trees with dense opaque foliage, such as the oak and the beech, or of evergreens, such as the Lucombe oak, &c.; and not of trees with open light foliage that may be seen through, like that of the robinia. With respect to culture, the roots of trees suitable for the background of a shrubbery ought to be such as descend, like those of the oak or the chestnut, and not such as spread immediately under the surface of the ground, like those of the robinia or the elm; which would soon ruin any border of shrubs, by depriving their roots of the greater portion of their nourishment. The errors in Mr. Rivers's notes are, however, scarcely worth noticing, when compared with those in his list of names.

But what we most deplore about Mr. Rivers's catalogue is, the baneful effect it must have on the minds of young gardeners wherever plants have been named according to it. The mere circumstance of a young man just beginning to acquire a knowledge of plants, being left to infer that it is of equal importance to distinguish between fourteen varieties of *Robínia* *Pseùd-Acàcia*, as it is between all the species of the genus, is enough to fill the mind with despair, and either deter a young man from further pursuit, or leave him to conclude that it is in vain for him to acquire anything like botanical accuracy. The Babel-like confusion, however, which prevails in Mr. Rivers's catalogue, being now pointed out, both in this Magazine and in the *Gardeners' Gazette*, it will be the fault of young gardeners themselves if they are misled by it.

Such an attempt as that of Mr. Rivers tends to show the great advantages that will result to gardeners and nurserymen from the establishment of public arboretums, with the plants correctly named, in different parts of the country; and it is a great satisfaction to us to know that the Derby Arboretum is in a central situation, and on what will shortly be the main road from London to Edinburgh and Glasgow, and from London to Liverpool and Dublin; and hence, that it will probably be visited by gardeners and nurserymen from all parts of the island.

It may be useful to those purchasers of trees and shrubs who wish to have correct names with them, to be informed that the whole of the collection in the Derby Arboretum, amounting to about a thousand species and varieties, was furnished, with very few exceptions, by Messrs. Whitley and Osborn of the Fulham Nursery.

Bayswater, Nov. 27. 1839.

ART. III. *On the Conduct of the Horticultural Society towards George Glenny, Esq., F.H.S.* Communicated by Mr. GLENNY.

I LAST year put up with many slights from the Horticultural Society, and among them that of exclusion from prizes, on the ground that I had refused one of their medals; nevertheless, I continued to send through the season some of the most important plants for exhibition.

On Tuesday last I sent four plants not very common, and on the contrary three of them were rather remarkable; but, notwithstanding everything else in the room was noticed by Dr. Lindley, my plants were not mentioned.

Now, I ask your readers whether such conduct is justifiable towards a Fellow of the Society, who has a right, as a partner, to his equal share of any profits and privilege the Society can boast?

It is true, I have condemned many acts of the Council and the servants, but though you may do these things more gently than I have done, you have, as a public journalist, exercised the privilege of condemnation and approval as every other independent writer would; and it should be remembered that I never advanced a fact that I was not at the time ready to prove.

Worton, Dec. 6. 1839.

ART. IV. *Notice of an Improvement made in the Mode of fixing Mr. Booth's Wire Trellis for Espaliers.* Communicated by W. B. BOOTH, F.H.S.

SINCE I forwarded the account you have published in Vol. XV. p. 630. of a wire trellis for espaliers, and the mode of erecting it, I have adopted another contrivance (*fig. 1.*) for fixing on the ends of the wires to draw them up, instead of the twisted

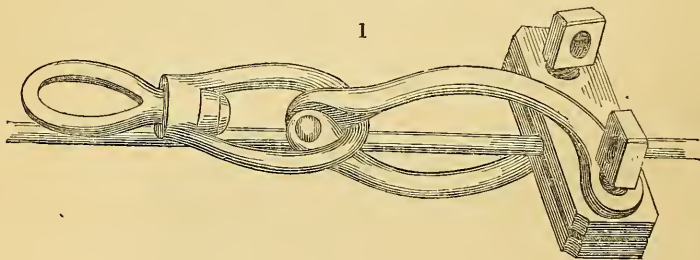

rope yarn formerly mentioned as having been used for that purpose. Perhaps it has little of novelty to recommend it to your notice; but any merit which it may possess belongs to Peter Copland, the blacksmith here, by whom it was constructed.

As it answers its purpose extremely well, and may probably be useful to others, I have great pleasure in supplying you with the accompanying sketch (*figs. 1. and 3.*) and description of it. It consists of two flat pieces of iron (*fig. 3. a a*), $2\frac{1}{2}$ in. long, $1\frac{1}{4}$ in. wide, and half an inch thick, having a couple of holes for the screws (*c c*), and a groove (*b b*) across the middle of each, nearly deep enough to receive the thickness of the wire. Two round claws (*d d*), 4 in. long, with a joint at (*f*) and a hole (*c c*) at the extremity of each, which is flattened for the purpose, are curved in such a manner that one of the ends may be screwed on the upper side, and the other on the lower side, of the two flat pieces, and by means of an eye and swivel, it can then be attached to the hook (*h*) of the instrument shown in *fig. 151.* in Vol. XV. p. 632. The annexed sketch (*fig. 1.*), representing the whole when screwed on the wire, will, however, convey a much better idea of the thing than any description.

Carclew, Dec. 4. 1839.

ALLOW me to point out a mistake of your engraver in the sketch of the wire trellis in Vol. XV. p. 632. By *fig. 153.* it would appear as if the blocks of stone, into which the uprights and stays are fixed, rested on a foundation of masonry: but this is not the case; the stones being so large and heavy, as to require nothing more than to be bedded in the places where they are intended to remain. To any practical person, such a foundation as is represented will appear quite unnecessary, but the fear of its misleading others has induced me to trouble you with this explanation.

Fig. 2. is the figure to which Mr. Booth refers, corrected agreeably to his directions. It may be useful to some of our readers to be informed that Mr. Booth's espalier trellis can be put up in any part of the kingdom by workmen sent from the

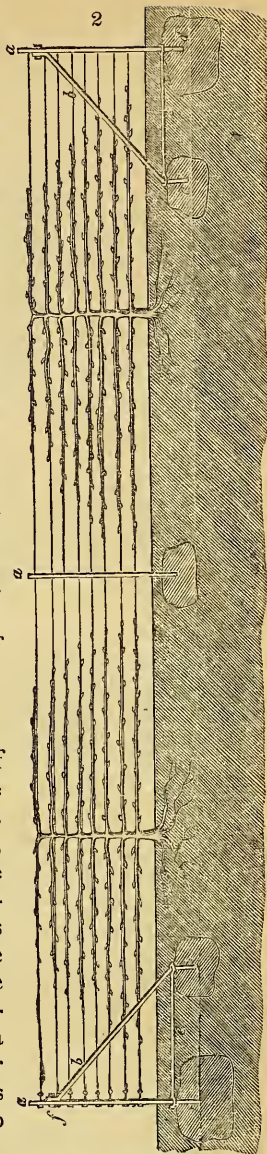

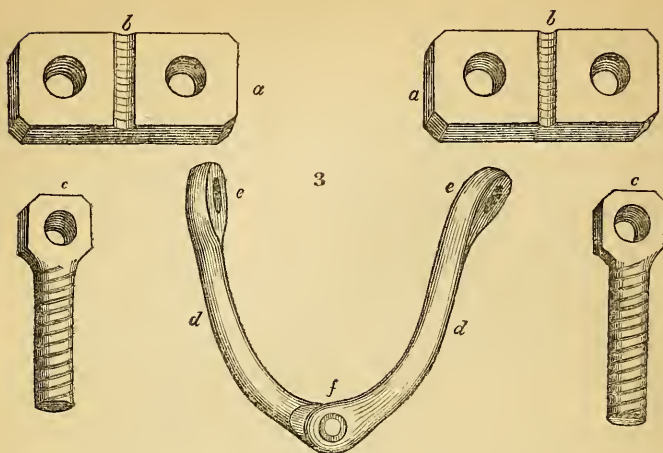

manufactory of Mr. Porter, No. 81. Upper Thames Street. When once properly known, we think those trellises will be preferred to all others. — *Cond.*

ART. V. *Botanical, Floricultural, and Arborescultural Notices of the Kinds of Plants newly introduced into British Gardens and Plantations, or which have been originated in them; together with additional Information respecting Plants (whether old or new) already in Cultivation: the whole intended to serve as a perpetual Supplement to the "Encyclopædia of Plants," the "Hortus Britannicus," the "Hortus Lignosus," and the "Arboretum et Fruticetum Britannicum."*

Curtis's Botanical Magazine; in monthly numbers, each containing seven plates; 3s. 6d. coloured, 3s. plain. Edited by Sir William Jackson Hooker, LL.D., &c.

Edwards's Botanical Register; in monthly numbers, new series, each containing six plates; 3s. 6d. coloured, 3s. plain. Edited by Dr. Lindley, Professor of Botany in the London University.

Paxton's Magazine of Botany, and Register of Flowering Plants; in monthly numbers; large 8vo; 2s. 6d. each.

The Floral Cabinet; in monthly numbers, 4to; 2s. 6d. each. Conducted by G. B. Knowles, Esq., M.R.C.S., F.L.S., &c., and Frederick Westcott, Esq., Honorary Secretaries of the Birmingham Botanical and Horticultural Society.

The Botanist; in monthly numbers, each containing four plates, with two pages of letterpress; 8vo; large paper, 2s. 6d.; small paper, 1s. 6d. Conducted by B. Maund, Esq., F.L.S., assisted by the Rev. J. S. Henslow, M.A., F.L.S., &c., Professor of Botany in the University of Cambridge.

Maund's Botanic Garden, or Magazine of Hardy Flower Plants cul-

tivated in Great Britain; in monthly numbers, each containing four coloured figures in one page; large paper, 1s. 6d.; small, 1s. Edited by B. Maund, Esq., F.L.S.

The Ladies' Flower Garden of Ornamental Annuals; in 4to numbers, monthly; 2s. 6d. each. By Mrs. Loudon.

RANUNCULA'CEÆ.

1631. CLEMATIS
+lathyrifolia Bess. Lathyrus-leaved ☿ Δ or 4 jn.au W ... 1836. D.S. co Bot. reg. 1839, 61.

A hardy herbaceous species of Clematis, with the leaves and fruit of *C. angustifolia*, but with much larger flowers, which are white, and arranged in a loose corymbose panicle. (*Bot. Reg.*, Nov.)

Fumariaceæ.

2047. CORYDALIS 31573 flavula Bot. Gard. no. 718.

Pittosporaceæ.

Sollya linearis Lindl. The flowers of this species are of the deepest and richest blue; the leaves are linear, or linear-lanceolate; and the fruit "much shorter and thicker." (*B. M. R.*, No. 132., Nov.)

Malvaceæ.

3489. ABUTILON
striatum Dicks. striated ☿ □ or 4 mr R.Y Brazil 1837. C co Botanist, no. 144.

The stem of this very elegant plant is scarcely shrubby, and the branches are very slender. It grows freely, and produces a great abundance of flowers. It is a native of Brazil, where it has a very extensive range; having been found on the Organ Mountains by Mr. Gardiner, and on the banks of the Rio Negro by Mr. Tweedie. (*Bot.*, Nov.)

Sapindaceæ.

3543. DIPLOPELTIS 29841 Hugèlii Bot. Reg., 1839, t. 69.

This very curious Swan River plant "proves to be a hardy green-house shrub," with pink flowers, "growing about 3 ft. high, and flowering in April and May. It requires the same treatment as such Cape plants as the hebenstreitias, striking freely from cuttings of the young wood; and it will bear to be planted out in the open border in summer. (*Bot. Reg.*, Dec.)

Balsaminaceæ.

698. IMPATIENS
picta Know. & West. pointed ?○ ?□ 2 jn Pk E. Indies 1837. S p Fl. cab. no. 123.

One of the East Indian species of Impatiens, raised from seeds presented to the Birmingham Botanic Garden by Dr. Royle. By some odd mistake, the natural order of this plant is marked in the *Floral Cabinet* as Leguminosæ § Ldteæ. (*Flor. Cab.*, Dec.)

Leguminosæ.

1985. LUPINUS
Barkeriæ Know. & West. Mrs. Barker's ☿ □ or 4 my.jn P,pk Mexico 1837. [cab. no. 122. D co Flor.]

A handsome suffrutescent species of Lupinus, a native of Mexico. It grows freely, and the stem is much branched. (*Fl. Cab.*, Nov.)

Rosaceæ.

1515. SPIRÆA 30755 barbata
Synonyme: Hoteia japónica Mor. & Decaisne.

Dr. Lindley, having received some ripe seeds of this plant from India, states that they "have an abundance of fleshy albumen, surrounding a straight cylindrical embryo, rather more than half their length." They are smooth and scobiform, with a lax testa, "prolonged at each end into a tapering withered sac." (*B. M. R.*, No. 133., Nov.)

Melastomaceæ.

+ LASIANDRA Dec. (From *lasios*, hairy, and *aner, andros*, applied to the stamens; there being a tuft of hair on the filaments of some of the species.)

+ petiolata Graham petiolated ☿ □ or 5 jn.jy Pa.P ?Brazil 1836. C co Bot. mag. 6673.

A very beautiful stove shrub, which Sir W. J. Hooker supposes to be the same as *L. Maximiliàna* Mart., a native of Brazil. The species is easily propagated by cuttings; and it produced abundance of its splendid flowers in the Glasgow Botanic Garden, in June and July, in stove heat. (*Bot. Mag.*, Dec.)

1181. OSBE'CKIA 30391 canescens *Fl. Cab.* no. 123.

Cactàcea.

1472. CERREUS

Martiànus Zucc. *Dr. Von Martius's*  or 2 ap Pk Mexico 1838. C p.l.s *Bot. mag.* 3768.

A species nearly allied to *C. flagellifórmis*, but with a somewhat erect stem. The flowers are long, tube-shaped, and pink; and the young fruit is green, about the size of a large nut, "and partially clothed with persistent tufts of hairs." It is a native of Mexico, and flowers abundantly during the summer months. (*Bot. Mag.*, Dec.)

1472. CERREUS 28290 squamuldsus.

Synonyme: *Lepismium commune* Dec., *Bot. mag.* t. 3763.

Rubiàcea.

Leptodermis lanceolata Wall. A nearly hardy small shrub, with bright strongly veined leaves, "and pale yellow flowers, tinged with purple. It is something like a cream-coloured bouvardia." (*B. M. R.*, Nov.)

Compósitæ.

2363. DA'HLIA 29803 *Barkèriæ* *Fl. Cab.* no. 127.

2373. ZA'MIA 21633 *angustifolia* L., *Fl. gard.* t. 35. f. 3.

Lobeliàcea.

609. LOBELIA

igneæ Hort. fiery  or 4 aus S Mexico 1838. D and C 1 *Paxt. mag. of bot.* vi. p. 247.

A very showy *Lobelia*, sent to England by Mr. Mackay of Liège, in 1838, and said to be raised from seeds received from Mexico. It appears more tender than its congeners, and has hitherto been kept in the stove; but Mr. Paxton thinks that it will succeed in a green-house, if carefully "protected from the frost, and very cautiously supplied with water. A damp atmosphere must be especially avoided." It is propagated by suckers, which it sends up in great abundance from the roots, or by "cuttings, taken from those shoots which do not flower, or from which the blossoms are timely plucked." (*Paxton's Mag. of Bot.*, Dec.)

Ericàcea.

1345. ARBUTUS 11075 *laurifolia* *Bot. Reg.* 1839, t. 67.

"This plant was introduced from Mexico by the last Lord Napier, and given to Mr. Lambert, who is of opinion that it is the true *A. laurifolia* of Linnæus's *Supplement*;" and in this opinion Dr. Lindley appears to agree. (*Bot. Reg.*, Dec.)

Convolvulàcea.

+ *Ipomœa púrga* Wend. Some confusion has arisen respecting the plant which produces the jalap, though all agree that it is a species of *Convolvulus* or *Ipomœa*. The fact is, that several Mexican plants belonging to this order are used for producing the drug; but it is from the fleshy root of *Ipomœa púrga* that the principal supply is derived. This plant has lately flowered in the garden of Thomas Harris, Esq., Kingsbury; and Mr. Beaton observes that "it seems to require a cool atmosphere, and plenty of room at the roots. . . . In the stove it grows too vigorously, without any disposition to flower." (*B. M. R.*, No. 136., Nov.)

+ *Batàtas betàcea* Lindl. A very beautiful species with pale violet flowers, having a deep purple eye. The root is tuberous, and resembles that of the red beet, both in size and colour. It blossoms profusely, and appears to prefer a cool atmosphere; though it is a native of Demerara. It came to England in 1838, a root having been accidentally imported among some orchideous plants. (*B. M. R.*, No. 152., Dec.)

Solanaceæ.

+ FABIANA Ruiz & Pavon. (In honour of *F. Fabiano*, a Spanish botanist.)
imbricatâ Ruiz & Pavon scaly z \square or 3 my W Chile 1838. C p.s Bot. reg. 1839, 59.

A very pretty little Chilian shrub, with scaly leaves like a *Thûja*, and white heath-like flowers, which it produces in great profusion. In its native country it grows on the sandy banks of rivers. It requires the protection of a greenhouse in winter, but in summer "it should be turned out of doors, but not exposed to too bright sunshine." It is propagated by cuttings, and should be grown in a mixture of peat and sand. There are plants in the nurseries of Messrs. Lucombe and Pince at Exeter, and Messrs. Rollisson of Tooting. (*Bot. Reg.*, Nov.)

Labiâtæ.

76. SA'LIVIA 719 pátula *Bot. Gard.* 714.

3451. GARDOQUIA 29981 multiflora *Part. Mag. of Bot.* vi. p. 223.

Thymelææ.

87. PIMELEA 805 incana *Bot.* no. 147.

This plant is stated in the *Botanist* to be the same as the *P. nívea* of the *Floral Cabinet*; the plant there figured not being the true *P. nívea* of Labillardière. (*Botanist*, Dec.)

Orchidæcæ.

2554. EPIDENDRON (*Encyclia*)
cepifôrme Hook. Onion-rooted y \square or 3 my O Mexico 1838. D p.r.w Bot. mag. 3765.

A very splendid species of Epidendron, belonging to the division considered as a new genus by Sir W. J. Hooker, under the name of *Encyclia*; but which Dr. Lindley thinks will not stand, and which Sir W. J. Hooker himself appears to have abandoned. The present species is a native of Mexico, whence it was sent, in 1838, by Mr. Parkinson, the consul there, to the late Duke of Bedford, at Woburn. (*Bot. Mag.*, Dec.)

+ *inversum* Lindl. A native of Brazil, nearly related to *E. frâgrans*. "The flowers are straw-coloured, with a few purple streaks on the column, and at the base of the lip, and have a heavy not very pleasant smell, something like that of ground ivy." Dr. Lindley proposes to include all the species of Epidendron, of which *E. frâgrans* may be considered the type, in one section under the name of *Osmôphytum*. (*B. M. R.*, No. 135., Nov.)

2542. CÆLOGYNE 29735 ocellata *Bot. Mag.* t. 3767.

elâta Lindl. This species has lately flowered in the Horticultural Society's Garden. "The leaves are more than a foot long," and the flowers are white, "stained with yellow near the point of the lip, and having an unpleasant smell, very like that of the berberry blossom." (*B. M. R.*, No. 151., Dec.)

376. LI'PARIS 30190 Walkeriæ *Bot. Mag.* 3770.

3566. GRAMMATOPHYLLUM [65; and *Paxt. mag. of bot.* vi. p. 217.
multiflorum Lindl. many-flowered y \square or 2 Br.G Manilla 1838. D p.r.w Bot. reg. 1839.

"This plant has very much the aspect of a gigantic *Cymbidium*, with long coriaceous leaves, distichous at the base." The raceme is large and handsome, but the flowers themselves want brilliancy of colour. (*Bot. Reg.*, Dec., and *Paxt. Mag. of Bot.*)

3538. CYRTOCHYLUM
mystacinum Lindl. whiskered y \square or 12 Y Peru 1837. D p.r.w Bot. reg. 1839, 62.

A curious little plant, a native of Peru, imported in 1837. When this plant was first mentioned in the miscellaneous matter of the *Botanic Register* for 1838, the flowers were described as "bright yellow white-coloured," instead of "bright yellow whole-coloured." (*Bot. Reg.*, Nov.)

2547. DENDROBIUM 29818 formosum.

5393. MILTONIA [vi. p. 241.
cândida Lindl. white-tipped z \square or 2 n Y.r.w Brazil 1838. O p.r.w *Paxt. mag. of bot.*

A very handsome species, flowering abundantly. (*Paxt. Mag. of Bot.*, Dec.)

+ *Specklînia obovâta* Lindl. "A small Brazilian plant, with the appearance of a *Pleurothâllis*." (*B. M. R.*, No. 137., Nov.)

Rodriguezia laxiflora Lindl. A pale-green-flowered Brazilian plant, "with a very lax nodding spike." (*B. M. R.*, No. 130., Nov.)

+ *crîspa* Lindl. The flowers have a crisped appearance, and "are sea-green, bordered with yellow;" their fragrance resembles that of primroses. A native of Brazil. (*B. M. R.*, No. 139., Nov.)

+ *Catasêtum proboscideum* Lindl. Nearly related to *C. cernuum* and *C. barbâtum*, of which last it may prove merely a variety. (*B. M. R.*, No. 140., Nov.)

longifolium Lindl. This plant has lately flowered at Battersea. The flowers are very numerous, and are produced on a drooping raceme; they are of a bright orange, bordered with violet. (*B. M. R.*, No. 154.)

Lælia flava Lindl. A native of Mexico, which, though it has been several years in England, flowered for the first time at Carclew, in the autumn of 1839.

+ *Dicrÿpta discolor* G. Lodd. Remarkable for the colour of the under side of the leaves, which is a deep purple. "The flowers are orange-coloured, and about the size of those of *D. Baûeri*." (*B. M. R.*, No. 145., Dec.)

+ *Octomèria diâphana* Lindl. A pretty little plant, with nearly transparent flowers, which are white and scentless. A native of Brazil. (*B. M. R.*, No. 146., Dec.)

+ *Fernandèzia lunifera* Lindl. The flowers are very large, and have a pair of supernumerary lobes at the base of the labellum, which "stand erect, like two curved horns." It is a native of Brazil, where it is found on trees. (*B. M. R.*, No. 147., Dec.)

Oncidium excavatum Lindl. "This fine Peruvian plant has flowered with Messrs. Loddiges. It has yellow flowers spotted with brown, and is easily known by the base of the labellum being very convex, a little hollowed out in front, and excavated with a deep pit on the under side." (*B. M. R.*, No. 150., Dec.)

Odontoglóssum Clowèsi Lindl. A Brazil plant, with "large strong flowers, yellow mottled with brown, while the lip is white, with a rich violet base." (*B. M. R.*, No. 153., Dec.)

+ *Pleurothâllis scâbrîpes* Lindl. A curious little plant, a native of Brazil, which flowered at Carclew in 1839. The flowers are small, of a dingy yellow, with reddish purple lines. (*B. M. R.*, No. 155., Dec.)

Iridacææ.

1907. PATERSONIA
sapphirina Lindl. sapphire $\frac{3}{4}$ 1 fl.au B Swan River 1837. s.p Bot. reg. 1839, 60.

Nothing can be more beautiful than the rich deep blue of the flowers of this plant, but, unfortunately, they are of very short duration. It is a native of the Swan River Colony, whence it was introduced by Mr. Mangles. (*Bot. Reg.*, Nov.)

Amaryllidacææ.

Clitánthes W. Herb. "The name *Clinánthus*, which was given from the obliquity which the flowers in Ruiz's specimen of his undescribed *Pancrâtium luteum* had taken in drying, is changed for *Clitánthes*, from *klitus*, a mountainous declivity, and *anthos*, a flower." Dr. Lindley describes three species, viz., *C. humilis*, *C. Macleánica*, and *C. lutea*, of which he had received notices from the Hon. and Rev. W. Herbert. They are all natives of Lima. (*B. M. R.*, No. 141., Nov.)

+ *Ismène defléxa* W. Herb. This species forms a connecting link between the genera *Ismène* and *Elisèna*. There are, indeed, several species of these two genera so closely allied, that it seems probable that the latter genus will merge into the former. Under this head, Mr. Herbert observes that "every *Ismène* delights in white sand, and every *Hymenocállis* in strong alluvial soil, and immersion in water." (*B. M. R.*, No. 142., Nov.)

*PENTLANDIA W. Herb. (In honour of J. B. Pentland, Esq., Consul-General in Peru.)
 miniata W. Herb. red-lead coloured ♂ Δ or 1 au.s R Peru 1839. O co Bot. reg. 1839, 68.
 P. m. 1 lacunda W. H.; P. m. 2 Suliváitca W. H. (Commodore Sullivan's.)

There are two forms of this species, differing very slightly from each other. The first was found in Cusco, in Peru, and was sent to Spofforth, under the name of the red narcissus, by J. B. Pentland, Esq., in compliment to whom the genus is named; and the other was found by Commodore Sullivan, during his command on the west coast of South America, in 1837. Both varieties flowered for the first time in England in August, 1839. (*Bot. Reg.*, Dec.)

Asphodelaceæ.

1050. THYSANOTUS
 intricatus Hort. intricate-stemmed $\text{3} \sqcup$ or $\frac{3}{4} \text{jl}$ P Swan River 1838. D [of bot. vi. p. 243.
 s.l.p Paxt. mag.

This little plant, though its stems are very slender, has them so curiously interlaced that they support themselves. Seeds of it were sent home from the Swan River in 1838. It is grown in sandy loam and peat, and requires plenty of water during the growing season, with perfect drainage. (*Paxt. Mag. of Bot.*, Dec.)

Echeandia terniflora Ort. Conanthera Echeandia Pers.; Anthéricum reflexum Cav. This singular plant flowered at Carlew in June, 1839. It is a native of Mexico, and was introduced in 1837. (*B. M. R.*, No. 144., Nov.)

Commelinaceæ.

1000. TRADESCANTIA
 spicata Know. & West. spiked $\text{y} \square$ or 150 P Mexico 1837. D co Fl. cab. no. 144.

A singular species, with an upright stem, and rather small dark purple flowers. A native of Mexico, introduced in 1837. (*Floral Cab.*, Nov.)

ART. VI. *On Conservative Walls, and their Superiority, as Sources of Botanical and Floricultural Interest, to Green-houses and Conservatories.* By the Rev. T. BAINBRIDGE, M.A.

I HAVE often wondered that more has not been said in your Magazine, than has hitherto appeared, on the subject of conservative walls. No one who has watched, for the last six or seven years, the conservative wall in the Horticultural Society's garden, can have failed to be struck with the great beauty and variety, joined to rarity, which that wall has displayed. Not only may the plants of the South of Europe, which are too tender to stand in the open garden, be brought to flower and fruit against such walls, but almost all the shrubs and trees of New Holland and Australia will grow against them with great vigour in the summer season; and, even if they are killed down to the ground during winter, if their roots are kept dry and protected through that season, they will spring up again the following summer with vigour. How different the appearance of the acacias and eucalypti of New Holland, when grown against such walls in the open air, from what they are when grown in pots under glass! The appearance made by the common myrtle, the pelargonium, the passion-flower, the loquat, the camellia, Lagerstrœmia indica, metrosideros, melaleuca, myoporum, and hundreds of others that will readily occur to every gardener, when planted against such walls, and properly treated, surpasses,

in my opinion, every other kind of botanical enjoyment which a garden has hitherto afforded. Even Chinese chrysanthemums and dahlias, when trained against such walls, have a very splendid appearance; and, under a slight projecting roof, I have known the dahlia saved from the frost, and continuing to show flower till Christmas, and the chrysanthemums till the middle of January. In a word, I consider a conservative wall as a very superior source of enjoyment to either a green-house or a conservatory; unless, indeed, these structures (as they are at Ashridge, and more particularly at Bromley Hill) are so connected with the living-rooms of the house, as to form a part of the suite of rooms.

I should therefore wish to see the subject of conservative walls taken up by yourself or by some of your practical readers, and the proper construction of such walls, the mode of planting them, the kind of plants suitable, and the management throughout the year, pointed out. In all this bearing in mind, that, while a green-house, or even a pit or any other glazed structure, is attended with some extra expense at first, and a good deal of expense annually to keep them in repair, the conservative wall may form a part of the boundary of the garden or pleasure-ground, or a screen to offices, or a connecting line of architecture between the house and offices, while its annual repairs may be considered as next to nothing. Only let the subject of conservative walls be once thoroughly entered into by gardeners and their employers, and I feel certain that the result will be one of the greatest additions that have been made to gardening enjoyments since the invention of green-houses.

London, Nov. 1839.

IN the *Suburban Gardener* we have, on various occasions, recommended a conservative wall; and, in *fig. 4.* we have slightly indicated a conservative wall, serving to connect the house with the offices and the kitchen-garden. In this plan, *a* is the entrance portico to the house; *b* the drawingroom, with three windows at one end opening down to the floor, and serving also as doors connecting this room with the conservatory. In the conservatory there is a broad walk down the middle (*c*), terminating in a door in the centre of its semicircular end; outside of which are steps descending to a circular basin and fountain, beyond which is the walk (*e*) in front of the conservative wall (*b b*); which wall commences at the conservatory, and extends to the kitchen-garden. The walk in front of this wall terminates in an archway (*i*), which forms the main entrance to the kitchen-garden; and on the lawn, in the angle at the left, is the symmetrical flower-garden (*l*). There is a walk at *k*, communicating with the other parts of the ground; and the wall on the right of that walk is also conservative, with a broad border between it and the walk, which can be heated below by pipes of hot water, conducted through a stratum of broken stones or bricks. Hot water is preferred to steam, as causing less expansion, and consequently less risk of derangement in the conducting pipes. The mass of stones, when once heated, will be several days in parting with that heat, unless in the case of heavy rains; so that, throughout the summer, the fire will only be required twice or thrice a week; and in spring, autumn, and winter the plants are supposed to be removed to a house. On the border,

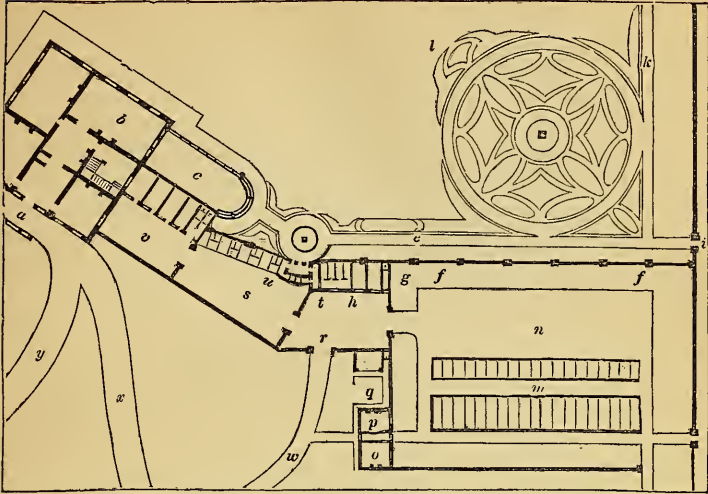

thus heated, melons, pine-apples, bananas, and a variety of other tropical fruits and flowers can be grown in the summer season, as if they were in their native country; the only evils to be guarded against being high winds and hail storms.

Opposite the fountain there is an open loggia with a seat; and on each side of this loggia is a small door, the one forming an entrance for the mistress to the poultry-yard, and the other an entrance for the master to the stables; here are also summer water-closets. In the reserve garden, the hot-houses and pits are shown at *m*; and the open area for composts, manure, &c., at *n*; *o* is the gardener's kitchen; *p* his living-room; and *q* his private garden, near which are a fuel-shed and a privy; *r* is the entrance to the stable court, in which, at *t*, there is the private entrance mentioned above, from the loggia. The stables, the two coach-houses, and a privy for the men-servants, are shown to the right and left of each. Here, also, is the fireplace to the flue in the conservative wall, and to the boiler which heats the tropical border. The poultry court is shown at *s*; and at *u* the private entrance to it from the loggia. The poultry-yard is supplied with water from the overflowing of the basin and fountain, carried to it under ground. The poultry have access to the stable court through a small opening in the wall, that can be closed at pleasure; and to the open lawn, and the kitchen court, through other similar openings. The kitchen court is shown at *i*; near which there is a servants' entrance from the approach. Part of the branch road leading to the stables is shown at *w*; part of the approach at *x*; and part of the sweep round the oval at *y*.

The conservative wall (*ff*) should not be a common erection, presenting only a flat perpendicular surface and a horizontal line at top: it may have piers at regular distances, terminating in caps surmounted by vases, above the height of the wall, but arranged in form and proportion so as to harmonise with the conservatory and the house. In the case of a Gothic or Elizabethan building, these piers and their terminating ornaments should, of course, vary accordingly. Instead of piers, the face of the wall might be broken by arched recesses; and, while a more delicate kind of plant was trained against that part of the wall which formed the back of each recess, a more hardy sort might be trained against the projections between them. We have seen a wall of this sort at Genoa, on which all the recesses were covered with roses, and the piers

with ivy; the effect of which was beautiful, as the roses continued in flower throughout the year. The same effect might be produced in England, by having the wall flued, and protected by matting during severe weather. Where the style was Gothic, the wall might be covered with a series of piers and intersecting arches; and, if the piers and impostes of the arches were covered with ivy, and the rest of the wall with deciduous plants, the effect, more particularly in winter, would be very striking. An excellent plan for varying such a wall is, to form the ground plan in a zigzag line, with piers at the angles; in which case, the length of each angle may be 10 ft., and the deviation from a straight line from 2 ft. to 3 ft. In going along the walk in front of such a wall, one series of angles would meet the eye; and, in returning, another series. Another plan is, to have the wall straight, and a temporary or permanent roof projecting from it. In this case, if the roof were permanent, it ought to be composed of glazed sashes, which might be taken off in the summer season, and used for growing melons, leaving the pillars and rafters which supported the sashes as fixtures; and these might be covered with rapidly growing climbing plants. Such a roof ought to extend over the walk, in order that the latter may be used during rainy weather in summer; and that, during the most severe frosts in winter, it may afford a somewhat more temperate place for taking exercise than in the open air. The most complete glazed veranda of this kind would be one where the whole of the skeleton framework, as well as the sashes, might be removed in summer, without leaving any marks to disfigure the scene, and replaced every autumn. A temporary veranda, in which the framework is to be covered with hurdles clothed with thatch, or with canvass fixed to framework or oiled paper, forms a very good protection for plants while in their dormant state; but requires to be removed much sooner in spring when they begin to grow, than a glass roof; because, when the plants begin to grow under an opaque roof, they become etiolated and blanched for want of light. In general, conservative walls should be flued, in order to give the gardener the power of assisting the ripening of the wood in autumn; and, in this case, the fireplace might be conveniently situated behind the wall, as indicated in the plan, at *g*, where it is placed in the corner of the stable buildings. A conservative wall may often form one of the sides of a range of office buildings; and this is the case with a part of the wall we are now describing, which forms the side wall to the stable (*t*) and coach-house (*h*).

ART. VII. *Notes on Cereus senilis and some other Mexican Plants.*

In a Letter from Mr. Tate of the Botanic Garden, Sloane Street, to Mr. Beaton. Communicated by Mr. BEATON.

I BEG to inform you that the first *Cereus senilis* I ever saw came to this country in September, 1823, also *Mammillaria latispina* [*Echinocactus cornigera* Dec.], and several other new species, which were introduced and presented to me by R. P. Staples, Esq., who was appointed consul-general of Mexico, after his first commercial trip there. I also purchased the same species of Mr. Bullock, in the following month of the same year, and it was described by Mr. Haworth in the *Philosophical Magazine* for 1823, from the specimens brought over by Mr. Bullock. I was extremely desirous that the *Cereus senilis* should be named after Mr. Staples, but Mr. Haworth said he could not consistently do so, as he believed it a true *Cereus*; and as Humboldt had previously described it as *Cereus senilis*, he

could not alter it; but, as you have discovered it to be a true *Echinocactus*, you may, consistently with botanical usage, adopt the name of *Echinocactus Staplèsia*, and affix that of *Cereus senilis* as a synonyme. Dr. Hooker, in his *Botanical Miscellany*, mentions that Mr. Cruikshanks discovered one in Peru, which I suppose you mean as the Brazilian species.

When Mr. Staples left Mexico for England, wishing to carry into effect my request of importing the hand plant [*Cheirostemon platanoides* *H. et B.*], he obtained several living plants, and planted them in a tub. Two days previous to his departure, he sent off a muleteer with a box of *Cacti* slung on one side, and the tub of hand plants on the other. The fellow, finding that one side of his load was considerably heavier than the other, emptied the major part of the earth, so as completely to destroy the young plants. You may perceive it was well the *Cacti* were not the heaviest, otherwise he would have taken them out, to do justice to his beast. On the arrival of Mr. Staples at Xalapa, he found all his hand plants dead. However, as it happened, I brought the first hand plant to this country from Mons. Cels of Paris, in the autumn of 1832, and had it in the market twelve months before Mr. Staples left Mexico.

Late in the evening, Mr. Staples, walking out in the suburbs of Xalapa, discovered the plant which has since borne his name, *Petrèa Staplèsia*; and he was so delighted with it, that he instantly dug up some young plants with the point of a sword, and made several dried specimens of its racemes of flowers upwards of 3 ft. long, which are now in the herbarium of Mr. Lambert. He (Mr Staples) also found the *Solandra guttata* of the *Botanical Register* at the same place, full in flower, and imported it with the *Petrèa*.

Although Humboldt had the credit of first describing most of the plants above mentioned, and enriched various herbariums with fine specimens of each, the British public and Europe owe their early introduction in a living state to the generous disposition of Mr. Staples, who must have expended a considerable sum in transporting them from Mexico to England.

Botanic Garden, Sloane Street, Sept. 16. 1839.

ART. VIII. *Practical Observations on the Cultivation of the Hyacinth in Haarlem.*

(Translated from the "Verhandlungen des Vereins," &c., of Frankfort on the Maine. By J. L.)

THE hyacinth likes a very sandy, well-prepared, fine, and light soil, without any appearance of stones or gravel, and which

consequently looks exactly as if it had been passed through a fine sieve. All kinds of loam or stiff soil which bind so closely together that, when dry, the wind cannot separate the particles as it does sand, must be avoided. No kind of red, bluish, or blackish soil will produce perfect hyacinths; but one is considered particularly good, which is light grey, and which resembles fine, very sandy, and light garden mould. This sand, which is very light of itself, is made still lighter by the addition of the thin sand of the Dutch downs (*Dünensande*), which is of a pale yellow colour, very fine, and contains neither stones nor gravel; and, as this sand constitutes the principal part of the mixture of soil, if nature denies us a supply of it at home, we must search for it in other places, or try to prepare one like it. Various soils have been used for this purpose, but the preference is given to a pale yellow river sand, to which is added a third of leaf mould. The bed is then prepared by putting into it a layer of cow-dung 1 in. thick, 5 or 6 inches under the bulbs, and filling it in with the prepared soil. This cow-dung must be quite pure, and not mixed with straw, or any other substance.

The soil, in consequence of the annual dunging, becomes by degrees too rich; in which case, the best way is, to take out some of the soil, and put in fresh sand. In Holland, however, they do not take out any soil, but only add sand, because by raising the bed, the danger of the water in the soil is avoided. In that country they have much to contend with in keeping the water from the soil; which circumstance must naturally occasion a great variation in the art of cultivating the hyacinth in drier soils. For example, in Holland, they dig the soil 5 or 6 feet deep, which would be unnecessary were it not that by this means the soil, which was stiff and sour from the water, becomes drier and lighter, and therefore better adapted for the escape of the injurious water and for evaporation. In countries where no such accumulation of water is to be feared, the soil need only be dug to the depth of 4 ft. or even 3 ft.

As the cultivation of the hyacinth has not made such advances in any part of the world as in Holland, by describing the soil, climate, and treatment of it in that country, it will enable those in other climates, with a use of their own understandings, to practise the art.

In preparing the soil, particular attention must be paid to two rules:—1. That, for the space of four years previously to planting, no horse-dung, nor any dung of a heating quality, must be mixed with the soil. 2. That no hyacinths must be grown in it oftener than once every four years. The latter rule must be particularly attended to; because, if planted a year earlier, the decayed remains of the old bulbs would communicate the

rot or other diseases to the newly planted bulbs. This being understood, a bed is planted the first year with hyacinths, the second with tulips, the third with narcissus, &c. ; and it would be desirable if something similar were planted even the fourth year. The bed, however, is generally prepared for hyacinths this year as follows :— Between December and February the ground is dug 5 or 6 feet deep ; and, when too much water is apprehended, a drain is dug all round the bed, and filled with wood or stones, and then covered up. In March every square yard is manured with four handbarrowfuls of pure cow-dung (without straw), dug in a foot deep. During the summer, vegetables or annuals are grown on the bed, which do not exhaust the soil too much. The following autumn (therefore the fifth), the soil is dug $1\frac{1}{2}$ or 2 feet deep ; and the manure, which was put in in spring, must be well mixed and worked in, that it may lie nearly a foot deep in the earth. When such a drain is not made, a trench is used, 2 ft. wide and $1\frac{1}{2}$ ft. broad, and left open, so that the water collected in it may be taken out.

When the above operation is performed, the bulbs must be prepared for planting in the beginning of October. This preparation consists in examining whether the bulbs are perfectly healthy ; because, if they are unhealthy, they not only will not flower, but will infect those near them. It is necessary, therefore, in the first place to be acquainted with the diseases they are liable to, which are :— 1st, the white rotz ; 2d, the black rotz ; 3d, the rot ; 4th, mould ; 5th, consumption or wasting ; 6th, shrinking ; and 7th, excess of offsets (*Durchwachs*).

1st. The white rotz is known by a resin which generally oozes from the upper part of the bulb, and also from the side, and which, about this time of the year (October), is of a hard consistency, not unlike the resin that flows from trees. The white rotz also assumes the appearance of a white slimy substance, and has a very unpleasant smell, which is particularly evident when the bulb is cut open ; and bulbs in this state should be thrown away without hesitation. The danger attending this disease will be treated of in another place.

2d. The black rotz is more difficult to know than the white rotz ; because, as soon as the bulb is taken out of the ground and kept dry, the rotz dries up also. The stool or plate of the bulb (that is, the point from which the roots proceed downwards), on the side, appears as if eaten out, and the scales at that part have dry black edges. When, therefore, there is but little of this disease in the bulb, it is more difficult to be ascertained ; and it must be particularly looked for, when the bulbs are about to be put in the ground, as it will not only destroy the infected bulb, but all those that are healthy near it. A bulb so attacked must therefore be thrown away.

3d. The rot is easily known when it is once fairly begun. It is generally found in the scales near the heart of the bulb; and, to discover it, the point of the bulb should be cut off horizontally with a sharp knife. If the bulb is affected with this disease, a yellowish or brownish stripe will be seen between the scales; and all the part thus discoloured should be cut away, till it is completely eradicated; but when it reaches farther than the half of the bulb, it is past remedy, and the bulb must be thrown away. Great care, however, must be taken, in cutting off the point of the bulb, not to injure the germ which has formed inside it; and when this is likely to be the case, the cuts ought to be made not horizontally, but in a slanting direction towards the point of the bulb; so as not to run any risk of cutting off the extremity of the incipient flower. It frequently happens that these stripes are but very little distinguished from the colour of the healthy part of the bulb; and, therefore, great attention is necessary, that they may not be overlooked. When two, three, or more stripes are seen round the heart of the bulb, it is generally past recovery; but if they are found far from the heart, and consequently near the outer scales, they can all be cut away, with the exception of such as have reached the stool and attacked it. Above all, care must be taken that neither the germ nor the stool of the bulb are injured; but all parts round them can be cut away.

4th. The mould is only found on the outer or inner part of the first four scales, and it is not considered a dangerous disease, but must be removed by taking off those scales that are attacked.

5th. Consumption or wasting is indicated by never-varying yellowish or brownish spots in the scales near the heart. This disease is not exactly a dangerous one, but is rather an indication of a weak flower, which is very frequently the case with several sorts; for example, the Grand Vainqueur, Staaten General, &c. These spots might go through the whole bulb without being injurious, therefore they are not to be compared with the stripes of the disease called the rot.

6th. Shrinking (*Verkrüppelung*) is indicated by spots similar to those above mentioned, only they are much larger. This disease generally draws the whole bulb in a slanting direction, and a part of it appears as if eaten out. The bulb loses its usual round form. This is similar to the disease called wasting, but in a greater degree, and is with great difficulty got rid of; therefore, if you wish to have good strong plants, it is better to throw those away that are attacked with this disease.

7th. Excess of offsets (*Durchwachs*) only takes place in bulbs capable of producing flowers. The offsets come out at the sides, or through the stool or plate, and the parent bulb becomes divided into a number of young ones. When this is the case,

it is left exactly as it is, and is planted like the others; and, although it will not flower, it will produce a great many young bulbs.

These are the principal characteristics of the diseases to which bulbs are liable. When you wish to increase them, great care must be taken, while they are out of the ground, not to pull off the small white offsets that have sprung out at the sides, and from the stool of the bulb; because this treatment, even if it does not injure the parent bulb, is sure to destroy the young ones, which would not be the case if they were allowed to remain on another year. When the young ones are older, and are become strong, they will have stools of their own, from which roots will proceed; and when in this state, they may without danger be separated from the parent bulb.

When the bulbs have been all carefully examined, they are planted thirty-six hours afterwards at the latest; because, as they have been probably very much cut, a longer delay would cause a reappearance of the mould, which would terminate in destroying them.

In our next Number will be given a year's culture of hyacinths, as practised in Holland; beginning with the season for planting in October.

ART. IX. *Observations on forcing Hyacinths.*

(Translated from the German, by J. L.)

IN order to make hyacinths flower in the beginning of December, they should be planted the beginning of August, and the pots plunged in the open air to such a depth that they may be covered with mould to the depth of 4 in.

They should be taken out again about the middle or end of October, put in warm tan or sand in a hot-house, near the sashes, and kept moist. The best sorts for this purpose are the Single blue January, Single blue Gallas, Single blue Impériale, and the Single white Impériale. The best kind of tulip for the same purpose is the Duc van Tholl.

If these sorts are treated in this manner, and kept moist and warm, they will not fail to flower about the beginning or middle of December. Many other sorts may be brought into flower about the beginning of January.

Those forced hyacinths which are intended to flower in February and March, should be planted in September and October, or even about the middle of November; the pots being plunged in the open air, and covered with mould. A bed should be made the beginning of January, consisting of horse-dung,

4 or 5 feet deep ; it should remain in that state about a week, and then as much mould added as will cover the pots when they are sunk in it. The pots should be now all put in, and the sash raised 4 or 5 inches, to admit air both night and day, so that the steam generated by the heat may readily escape. This must not be neglected even during frosty weather ; otherwise the hyacinths will be burnt.

During a severe frost it may be thought that admitting the air is quite unnecessary, but it must not be omitted, only hanging cloths over the opening ; as if air be not admitted, all the hyacinths will be found burnt up the following morning.

REVIEWS.

ART. I. *Catalogue of Works on Gardening, Agriculture, Botany, Rural Architecture, &c., lately published, with some Account of those considered the more interesting.*

THE Elements of Botany for Families and Schools. Published under the direction of the Committee of General Literature and Education, appointed by the Society for promoting Christian Knowledge. 4th edition, small 8vo, pp. 139, numerous woodcuts. London, 1839.

One of the best little books of the kind which we have seen, embracing structure, physiology, and classification. At the end there is a useful list of plants, in four columns, the first containing the English or popular names of all the plants, the products of which, or any part of which, are in use in the arts, or in general economy ; the second, their scientific name ; the third, the name of the natural order to which they belong ; and the fourth, their Linnæan class and order. Besides the woodcuts, representing leaves, buds, roots, &c., there are pictorial representations of Dicotyledonous and Monocotyledonous plants.

Cactearum Genera nova Speciesque novæ, et omnium in Horto Monvilliano cultarum ex Affinitatibus naturalibus Ordinatio nova Indexque Methodicus. Auctore C. Lemaire. 8vo, pp. 115. Paris, 1839.

This is an attempt at a new arrangement of the Cactææ, in which the genera are disposed in linear series, by their affinities, and separated into two tribes by their mode of germination. The author develops his plan as follows.

“The Cactææ separate themselves, at first sight, into two divisions ; one consisting of plants with elongate stems, leafy or leafless, jointed or continuous ; the other of plants with stems low or nearly wanting, globose, simple or branched : thus, by easy and convenient comparison, they are linearly arranged in the most natural manner.” After long and anxious pondering on the best way of separating the series into these divisions by a botanical character at once simple and precise, “the mode of germination flashed across his mind, and his heart leaped for joy.” The author proceeds : “Having discovered this guide, I formed all the caulescent Cactææ with true foliaceous cotyledons into my first tribe, which I named Phyllariocotyledonæ ; and the globose or stemless with true tuberculate cotyledons into my second, which I named Phymatocotyledonæ. From this character flows the following physiological law : ‘Amongst the Cactææ, the form of the cotyledons indicates the habit, and consequently the mode of vegetation, of the future plant, and affords the best character for separating them into two natural tribes.’

“The germination of Cactææ may be divided into three periods common to

both tribes, although the result is diametrically opposite in each; the stem in the first being long, and upright or creeping; in the second globular, simple, branched or many-headed. The genus *Pilocereus*, which forms the passage from the one tribe to the other, is the only exception. During the first period, in both tribes, the seed swells, the epispERM separates from the hilum, and the descending stem issuing from the widening fissure turns towards the earth; at the same time, the ascending stem rises, carrying up the torn epispERM. During the second period, the tribes begin to differ in appearance. The epispERM has fallen off, and the ascending stem has become a primordial merithallium; but, in the *Phyllariocotyledonæ*, it bears on its summit two ovate and slightly acute cotyledons, while in the *Phymatocotyledonæ* they are distinctly tuberculate. In both the descending stem becomes the root, and buries itself in the soil preparatory to the emission of radicles. This latter operation seems subject to the evolution of the cotyledons; for after a short time, in both tribes, these recede from each other, and some very minute radicles appear round the root, and then, opposite to the cotyledons, are seen the two earliest tubercles bearing the rudiments of bundles of prickles, which, evolving themselves opposite and alternately, form at length the future stem. During the third period, the difference between the tribes is striking. In the *Phyllariocotyledonæ*, the foliaceous cotyledons are obliterated; the merithallium is nearly buried in the soil, and becomes the true collar; whilst between the two cotyledons peaks up the caulicula already indicated by the first two fascicles, and afterwards increased by the spiral evolution of new ones. In the *Phymatocotyledonæ*, on the other hand, the merithallium arises from new tubercles, bearing bundles of prickles, becomes globular from the continuous evolution of others, and finally increases to a caulicula, more or less globose, and always buried. Thus it is easily perceived that each tribe has a peculiar and opposite mode of germination."

Such is the reasoning by which the author supports his theory. To show how he carries it out in practice would take up too much space in a work devoted more to the garden than the study. We must therefore content ourselves with stating that, of his two tribes, the first, or *Phyllariocotyledonæ*, contains six genera; *Peirésia* Plum., *Opúntia* Tourn., *Lepismium* Pfeiff., *Hariöta* Adans., *Epiphýllum* Herm., and *Cereus* C. Bauh.; the second, or *Phymatocotyledonæ*, seven; *Echinonyctánthus* Lem., *Echinocactus* L. & O., *Mammillária* Haw., *Anhalónium* Lem., *Melocactus* C. Bauh., *Pilocereus* Lem., and *Astróphytum* Lem., the place of the last uncertain.

Recensio Specierum Generis Pteridis. Auctore Jac. G. Agardh. 8vo, pp. 86. Lund, 1839.

The object of the work is to rescue the genus *Pteris* from the confusion into which it had fallen, in consequence of the number of new species added since the revision of Willdenow. For this purpose Dr. Agardh, not content with the Swedish collections, travelled into England, Scotland, France, and Germany, to scrutinise the rich herbariums to be found in those countries. His original design was to publish a monograph of the genus; but, in the meantime, the appearance of the valuable work of Presl rendered such an undertaking unnecessary, and the doctor contracted his views to a searching examination of the species. Presl had, in the professor's opinion, pushed the use of venation too far in employing it as a generic diagnostic; and, by so doing, had formed genera which the latter has reunited to *Pteris*, confining this character to the discrimination of subdivisions of genera only. He divides the genus into four sections, of the value of which the subjoined characters will give an idea.

1. *Eùpteris*. Petioles fascicled, greenish or straw-coloured, rarely purplish; a transverse section of the fascicle of vessels having the shape of a horse-shoe, frequently incurved at the apex. Fronds pinnate; veins parallel, approximate, simple or 1—2-forked, rarely anastomosing at the apex or the basal ones forming an arch. Species 1—53.

2. *Ornithópteris*. Petioles scattered, green or straw-coloured; fascicles of

vessels numerous, much separated. Fronds becoming decomposed and leathery; veins parallel, approximate, many times forked, prominent on the under surface, and depressed above. Species 54—61.

3. *Litobròchia*. Petioles fascicled, greenish or straw-coloured; a transverse section of the fascicle of vessels having a wavy horseshoe shape. Fronds more or less divided; veins reticulated. Species 62—89.

4. *Histiópteris*. Petioles scattered (?) generally shining-coloured; a transverse section of the fascicle of vessels having a wavy horseshoe shape. Fronds decomposed, pinnate; pinnules pinnatifid, the lowest on each pinna heteromorphous: basal veins arched; secondary forked, free or anastomosing. Species 90—94.

A second part, comprising the cognate genera, is promised.

Catalogus Plantarum Horti Botanici Hafniensis. Conscriptis O. J. N. Mörch, Hortulanus. Pamp. 8vo, pp. 102. Copenhagen, 1839.

The arrangement is alphabetical, and includes house as well as hardy plants. The total number of species and varieties is about 8000. The garden appears rich in hardy herbaceous plants, including grasses. Of *Alliums* there are above seventy species, of *Achillæa* above fifty, of *Amaránthus* nearly fifty, of *Agróstis* twenty-five, of *Aíra* sixteen, *Acer* eighteen, *Acácia* about forty sorts, and so on.

A Treatise on Agriculture, adapted to the Soil and Climate of Ireland, comprehending the Nature, Properties, and Improvements of Soils; the Structure, Functions, and Cultivation of Plants; and the Husbandry of the domestic Animals of the Farm. By John Sproule. 8vo, pp. 709, numerous wood-engravings. Dublin, 1839.

“The object of the author has been to present the farmer with a manual to which he might at all times refer with safety, embracing every department of his profession, describing every operation which he has to perform, and, as far as the practical character of the work would admit, showing the connection which should subsist between the theory and practice of the art.

“In the execution of this task, various authorities, oral and written, have been consulted; from which numerous and important additions have been made to the work. Reference has not always been made to these, it being conceived, that no useful purpose would be served thereby, and that the space thus taken up could be much more profitably occupied. The works consulted without acknowledgement being always made, are, the *Encyclopædia of Agriculture*, the *Quarterly Journal of Agriculture*, Lawson’s *Agriculturist’s Manual*, Low’s *Elements of Practical Agriculture*, Lindley’s *Introduction to Botany*, and Youatt’s valuable *Treatises on the Domestic Animals*.

“The author has also to express his obligations to Mr. Campbell and Mr. Maxwell; the former, head farmer, and the latter, head master of the Templemoyle Seminary, for several alterations and additions to the manuscript before going to press.” (Pref. vii.)

The volume, in bulk and general appearance, has a close resemblance to Low’s *Agriculture*, reviewed in our Vol. XIV.; and, on comparing the contents of both volumes, we find the same headings in each, only differently arranged. It is but justice to Mr. Sproule, however, to state that, though he has imitated, he has not exactly copied, and that his imitation is sufficiently artistical to constitute a distinct book.

First Report upon Experiments upon the Action of Sea and River Water, &c. By R. Mallet, M.R.I.A., &c. Pamp. 8vo, 1 plate. London, 1839.

The action of salt water on iron is much greater than that of fresh water; but all the different phenomena which take place have not been yet satisfactorily accounted for. This report briefly recapitulates all that has been hitherto published on the subject, and points out the track of experiment that ought to be pursued in future investigations.

The Use and Advantages of Pearson's Draining Plough. By T. L. Hodges, Esq., M.P.

This plough has been described and figured in the *Encyclopædia of Agriculture*, 2d edit. p. 710. We should be glad to know from any correspondent whether it is much used, as we know only of one instance, that of Sir C. M. Burrell, Bt., M.P., at Knepp Castle.

The Visitor's Guide to Knole, in the County of Kent, with Catalogues of the Pictures contained in the Mansion; a Genealogical Descent of the Sackville Family; and Biographical Notices of the principal Persons whose Portraits form Part of the Collection. By J. H. Brady, F.R.A.S. Illustrated with engravings on wood by Bonner, Sly, and others. Foolscap 8vo, numerous woodcuts.

A very interesting guide to one of the most remarkable old family mansions, or we might even say palaces, in England. The biographical notices of the portraits are very curious, and the descriptions of old trees, and other particulars in the park and gardens will amuse the gardener; while the architect will be instructed by the engravings of different parts of the house, and of the ancient furniture, more particularly of the fireplace, fire dogs, chairs, tripods, masks, sconces, &c.

Remarks on Mr. Espy's Theory of Centripetal Storms, &c. By W. C. Redfield. Pamp. 8vo, pp. 32. New York, 1839.

Mr. Redfield endeavours to show the physical impracticability of a centripetal movement in the atmosphere, over a surface of several hundred miles in diameter, towards the centre of a storm; alleging that, instead of the accumulation which must inevitably result from a centripetal movement in the air, its state of diffusion, or centrifugal movement, is known by the indications of the barometer to be unusually increased. To understand the subject thoroughly, the pamphlet must be studied in all its details.

Revue générale d'Architecture et des Travaux Publics, &c. General Review of Architecture and Public Works; a Journal for Architects and Engineers, Antiquaries, Builders, and Proprietors. Conducted by M. César Daly, Architecte. No. I. Imp. 4to, pp. 64, 3 lithographs and numerous woodcuts. Paris, 1839.

This is the commencement of an architectural magazine, and it promises to be one of a very superior description, in point of paper, printing, and engravings. This first number, after a general introduction pointing out the importance of the art of building, contains articles on the history of Byzantine architecture, illustrated by five plans and three elevations of celebrated Byzantine churches or cathedrals; on the importance of architectural museums; the theory of suspension bridges; on a new system of carpentry in wood and in iron; on bitumens, and the different modes of employing them; and, lastly, one on certain buildings, built of unburnt bricks, found in the South of Russia. The bricks are formed of compressed earth, and the walls bear a close resemblance to those built in the *en pisé* manner of the French. This article, as well as the last, is illustrated with several wood-engravings. The number concludes with several pages of reviews and miscellaneous intelligence, including a review of a work by M. Tessereng on the public works of Belgium and France. To all engaged in building or engineering pursuits, and to country gentlemen who wish to keep pace with the progress of the times in their knowledge of territorial improvement, such a periodical cannot but be acceptable: to those who have a taste for architecture it must be more especially interesting.

The British Almanack of the Society for the Diffusion of Useful Knowledge, for the Year 1840. Sm. 8vo, pp. 96. London, 1839.

The Companion to the Almanack; or Year Book of general Information for 1840.
Sm. 8vo, pp. 263. London, 1839.

These volumes possess their usual value as almanacks, though the *Companion* contains rather less than it did last year of matter which can be rendered directly available to the gardener as such. There is, as usual, an excellent article on metropolitan improvements, and on the churches and other public buildings erecting in different parts of the country. Next year, we hope this article will contain some account of the public gardens or arboretums forming in different parts of the country, as at Leeds, Bath, Newcastle, Edinburgh, Derby, &c.; and by that time, also, we hope the garden in the Inner Circle, Regent's Park, will have made some progress.

MISCELLANEOUS INTELLIGENCE.

ART. I. *General Notices.*

THE Peach and the Nectarine the same Species. — Dec. 1. 1835. Planted twenty stones of peaches, which had been kept in sand since August last. Sept. 1839. These stones came up the following summer; one of the trees bore fruit in 1838, and proved to be a nectarine of excellent flavour; another tree fruited this year (1839), and is also a nectarine (free stone) of excellent quality; proving the correctness of your opinion, "that the peach and nectarine are essentially the same species." Query? As far as this goes, is it not evidence that the smooth-skinned peach, or nectarine, is the more original? — *T. C. Brown. Farther Barton, near Cirencester, July, 1838.*

Superiority of Mr. Hoare's System of pruning the Vine. — Three years since, I transplanted a vine of several years' growth, preserving the roots as long and uninjured as possible, against the wall of a barn in a southern aspect. The ground was previously trenched to the depth of 2 ft., the bottom being dry, and the soil calcareous. This vine was managed according to the plan recommended by Mr. Hoare; two shoots being left last autumn for bearers, and two cut down for new wood. This spring, the two shoots, each having twelve buds, with the buds on the stools, and one or two pushed from the old stem, produced 152 bunches, most of them very large. Six other vines, managed on the same plan, were full of promise, and no instance of failure occurred. This success, coupled with the simplicity of Mr. Hoare's system of pruning, strongly recommend it for adoption. If generally followed, grapes would be as common in England as gooseberries and currants; would that we were equally sure of ripening them! — *Id.*

A Device for serving the Bees of any Hive with Food when they need it. — Let the crown of the hive be perforated with a circular opening $2\frac{1}{2}$ in. across. Provide an instrument of the following structure, which can only be made in a finished manner by a turner: — A circular wooden dish, $7\frac{1}{2}$ in. across, $2\frac{1}{4}$ in. in external height, and $1\frac{3}{4}$ in. in internal depth; its floor perforated in the centre by a cylindrical funnel $1\frac{5}{16}$ in. in height, as measured from the floor of the basin, and about 2 in. over. The interval between the wall of the dish and the wall of the funnel is to contain the food designed for the bees. A circular board, $6\frac{1}{4}$ in. across, not quite $\frac{2}{8}$ of an inch thick, perforated with numerous holes, arranged in four concentric circles, and with a large hole in its centre, $2\frac{3}{8}$ in. across, which admits the funnel through it, is provided to float on this food. A lid, $6\frac{5}{8}$ in. across, $\frac{2}{8}$ or more of an inch in thickness, and furnished in its central part with a circular pane of glass, about $3\frac{1}{2}$ in. across, covers the funnel, float, and food, and is received into a ledge, made about $\frac{2}{8}$ of an inch deep on the inner edge of the top of the wall of the dish. In applying the instrument, the base of the funnel is placed over the opening in the top of the hive. The bees pass up the funnel, whose height allows them free passage between the top of it and the lid: they descend to the surface of the floating board, and take their food through the holes perforated in it. The glass in the lid allows the person who has the care of the bees to see when

they need a fresh supply of food; and the lid and the floating-board have each an upright peg or two fixed in them to enable him to remove either at pleasure. The advantage of the whole machine is, it enables the bees of the hive to which it is applied to take their food without being exposed to the weather, or without molestation from the bees of other hives.

I understood Mr. Levett to deem himself the inventor of this excellent instrument; and this may be quite true, for no one who knows Mr. Levett will doubt his veracity; but there may have been other inventors of it. On my describing the instrument to Mr. James Barrett of Bury St. Edmunds he stated that his late employer, the present Sir Thomas George Cullum, Bart., had possessed a similar instrument nine or ten years ago, but with the lid made wholly of glass. A neighbour of Mr. Levett's turns and makes the bee-dishes, and sells them at 3s. 6d. each. Mr. Levett spoke very approvingly of Jonas de Gelien's work called the *Bee-Preserver* (London, 1829, 8vo, pp. 134, price 3s.). — *J. D.*

To destroy Worms. — A correspondent has sent us M'Dougal's recipe, which is: — Roll the lawn twice; then water it with lime water, at the rate of one pint of lime to ten gallons of water. The operation, twice performed, will destroy every worm, without injuring the grass. Or, mix a quarter of an ounce of corrosive sublimate with three gallons of water, and the same effect will be produced. — *A Subscriber.*

Wettested's patent Metal. — We recommend gardeners who are curious in making tallies for plants in pots to make trial of this metal. It will take the impression of types or figures almost as well as lead, while it is stiffer, and less likely to bend by frost or heat. It appears, also, to be equally durable as lead. We are not aware that it has yet been tried for piping, either for heating by hot water, or conveying water under ground for fountains, &c., but we think it well deserves a trial for these purposes. — *Cond.*

Grafting the Lilac on the Ash. — This season I grafted the different species of lilac upon the common ash, in accordance with some information I received from a friend (Mr. Wolff, jun.), while I lived in Paris. I do not recollect to have seen any account of any one having tried the same in this country. We had grafted here about three dozen ashes, varying from 4 ft. to 10 ft. in height with the common and Persian lilac; and I am happy to say that the result has exceeded my most sanguine expectations; for we have now growing about twenty fine healthy plants, with branches from 1 ft. to 18 in. long, which I hope, in another year, to see covered with bloom. They were grafted in April, after the lilacs had made considerable shoots. I would therefore advise that the scions be taken off in January or February, in order to retard their vegetating too soon for the stocks. Would not the pendulous ash form a beautiful object by having its branches grafted with Persian lilac? — *J. Scott. Millford Nursery, Sept. 7. 1839.*

Use of Lime in Planting Trees. — In most plantations there is a loss of about 8 per cent on the plants, from frost or other causes, and the great object of the forester is to accelerate and secure their growth the first year. On this head we can give a useful hint from the experience of Darnaway. One hundred and fifty acres have, within the last two or three years, been planted there without a single instance of loss, and this has been achieved by a very simple process, which merits the name and the honours of a discovery. It is merely putting a small quantity of lime into the hole in which the plant is laid. About four bushels of lime will suffice for an acre: it is thoroughly mixed and incorporated with the mould, before the plant is inserted. The effect of the lime is to push on the growth of the plant in its first and most precarious stage: new fibres begin to form and ramify from the taproot, and not only is the growth of the plant secured, but it is advanced in a double ratio, compared with the ordinary system where no lime is used. We saw this process in operation two years ago, and were not a little anxious as to the result of the lime. We had great faith in the sagacity and practical knowledge of Mr. Cutlar, the forester, but we confess we had a doubt that

liming the plant would force it on prematurely, and that after a brief season of remarkable growth it would be found deficient in stamina, and decline as rapidly as it had arisen. Experience and observation have dispelled these fears. The plants are thriving steadily and vigorously in the most exposed parts of the forest; and, the dangerous period of their existence being over, there seems no doubt that they will continue to assert and maintain their superiority of growth over their brethren of the forest. Indeed, we anticipate that in a short time lime will be universally used for this purpose, as it is in the operations of agriculture. The person that first used lime for manuring his land in Ross-shire was Major Mackenzie of Fodderty, and many of his neighbours shook their heads in wonderment and pity at the adoption of such a scheme for "burning up the land." The worthy major, however, triumphed over all the unbelievers of the district, and has lived to see the universal adoption of lime, as well as another potent auxiliary of the soil, bone dust. May we not hope for a similar result as to the application of lime in our forest plantations? With respect to quality of soil, we need only remark that, wherever ferns grow strong and abundantly, oaks will thrive and prosper; and it is on a soil of this description that lime has been found to answer in the nurture of plants. (*Inverness Courier*, Oct. 16. 1839.)

New Kinds of Wheat. — I herewith give you the particulars of the cultivation of fifty-five sorts of wheat which you so kindly submitted to me for experiment. The conclusion arrived at from the cultivation of the small wheats (*Triticum sativum*) may be briefly stated, viz. that they are every one inferior to the most approved sorts grown in the district, with which they were compared. The Blé de Lammas rouge sans barbe is probably the best, being hardy, healthy, and productive, and the grain being of good quality, but it is deficient in produce of straw, and from its velvety chaff is liable to be damaged from wet in harvesting. The Poulards or Rivets promise better. Three varieties I have chosen for further experiment; Patineillé blanc d'orient, for its superior grain, Poularde d'Auvergne à epilony, for early maturity and productiveness, and also Blé de St. Helena. I need scarcely say that the experiment has been highly interesting in affording an opportunity for observation, and especially in exemplifying the difference of habit in the same plant, some varieties being found so much more liable to be affected by mildew, red gum, fly, or lodging, than others. — *John Clarke. Saffron Walden, Nov. 15. 1839.*

Sida Abùtilon L., a malvaceous annual, has lately been brought into culture by W. Taylor, F.L.S., of Holbrooke, near Ipswich. From experiments it appears that the plants succeed best when sown in May, as they arrive at perfection in three months and a half. The quantity of seed required for an acre, when sown in drills, is about 8 lb. Mr. Taylor sowed 5 rods of ground at Old Brompton, which produced 50 lb. of fibre, or at the rate of 15 cwt. of saleable fibre per acre. Some of the fibre he had manufactured into excellent ropes, by Mr. Buckingham, hemp and flax manufacturer, Broad Street, Bloomsbury. The maceration of the smaller stalks is finished in about six days, and of the larger in twelve days. *Málva crísipa*, *M. peruviàna*, and *M. mauritiàna* also produce fibre which might be applied to the same purpose as that of *Sida Abùtilon*; more especially *Málva crísipa*, a very common annual in British gardens. — *W. T. London, Nov. 1839.*

Màdia satíva. — This new oil plant, first brought into notice in this Magazine by M. Hertz of Stuttgart, has been grown on a considerable scale last summer, by Mr. Taylor, at Holbrooke, near Ipswich. One acre of very poor stiff clay loam, which otherwise would have been left a naked fallow, was sown on March 5. with 5 lb. of seed; and, about the middle of August, the crop was mown and dried like hay, and carried to the barn and threshed. The produce was 33 bushels of fine seed: 8 bushels of this seed weigh 320 lb.; and 320 lb. yielded 50 lb. of oil, and 108 lb. of oilcake. The total produce of the acre was 250 lb. of oil, and 410 lb. of oilcake. The oil is worth 5s. a gallon of 7 lb.; so that, independently of the value of the oil-

cake as food for cattle, and of the straw as manure, the oil produced nearly 9*l.* per acre. — *W. T. London, Nov. 1839.*

Three new improved Kitchen-Ranges. — I have within the last week seen in operation three different specimens of an improved kitchen-range (said to be “patented”), and all founded on the Arnott principle of economising the fuel used, and giving the utmost effect to the heat produced. The first is the invention of Mr. Brown, an ironmonger of Luton, Beds. Its appearance is that of an ordinary range with oven and boiler, with the front and top of the fire-grate shut in, and the space beneath the bottom also partially enclosed. The fireplace is cased with fire-brick on the back and sides, and an iron plate forms the front, which, becoming red hot, supplies the heat necessary for roasting; when not in use for that purpose, it is screened by an outer plate sliding in grooves on either side: a portion of the top plate is removable to afford an opportunity of boiling, frying, broiling, &c. The fire plays round the oven, and partly under the boiler, and the vapour escapes by a pipe into a chimney or otherwise. The top forms a hot plate. The space under the grate bottom in front is enclosed in part with talc, and the drawer for receiving the ashes occupies the remainder. There can be no doubt of the improvement effected in this range in the avoidance of smoke and dust, economy of fuel, &c., over the common range; the oven and boiler appear to act as well, too, in every respect; and the inventor assured me that he had roasted a leg of mutton by the red-hot plate of 19½ *lb.* weight. This range is made in different sizes, and sold at from 7 to 10 guineas each.

The second, viz. Wright’s Kitchen-Range (see Vol. XV. p. 728.), is to be seen in operation daily in Arthur Street, near the Monument. The only difference between it and the above appears to be, that in the latter the front of the fire-grate is enclosed with talc, and through this talc it is said that sufficient heat is radiated to roast meat. It is also provided with the necessary appurtenances for boiling, steaming, frying, and broiling. These included, the price is from 30 to 40 guineas.

The third kitchen-range is now exhibiting in White Lion Court, Cornhill. It dispenses with the means of roasting, and has two ovens in the larger-sized range, and only one in the smaller. It has a boiler above the oven, and a hot-closet under. This is also fitted with stew-pans and fish-kettle, the top forming a hot plate. The price of the smaller ones is 13*l.*; that of the larger from 35*l.* to 45*l.* — *W. Wilds. Hertford, Dec. 1839.*

Kirkwood’s Stove. — This stove consists of two distinct parts. An outside

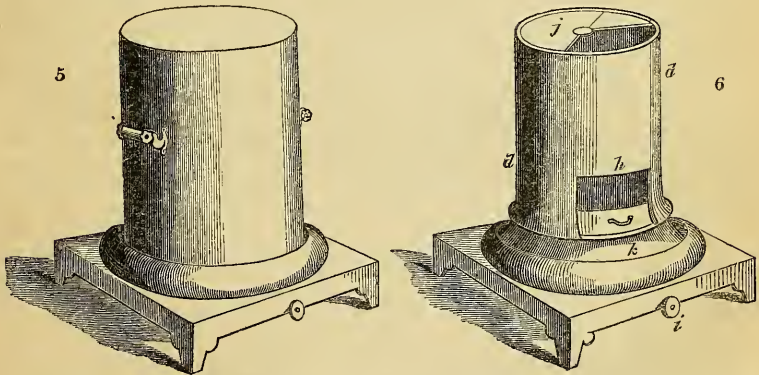

case of thin sheet iron, which may be removed at pleasure; and an inside stove or fire-place which may be used either with or without the outside case.

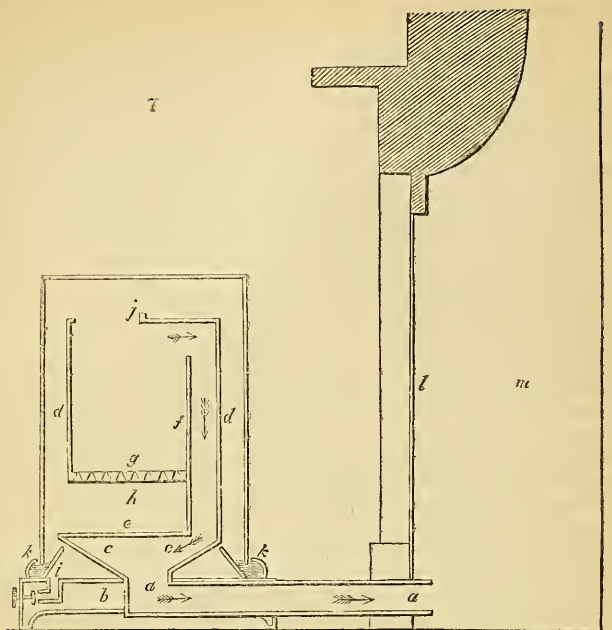

Fig. 5. is a perspective view of the stove with its case; fig. 6. a view of the stove or fireplace with the case removed; fig. 7. a section showing its construction. The arrows mark the direction of the smoke in the descending flue. *a* is the smoke-pipe that enters the chimney (*m*) at the bottom, which may in ordinary cases be closed by an iron plate (*l*). The smoke-pipe enters through the bottom plate of the stove (*b*), in which is a groove (*kk*) filled with sand to receive the bottom of the outside case. *cc* is a conical piece with a ledge to receive the cylindrical trunk (*dd*) which forms the fireplace; *c* a plate forming the bottom of the ashpit and part of the flue; *f* a plate which forms the back of the fireplace, and also part of the flue; *g* the fire-grate; *h* the ashpit; *j* the cover of the stove, half of which turns on a centre, and may be left more or less open, and by which, also, the fuel is introduced. *i* is the valve by which air is admitted to the stove, when the outside case is in use. Now, it will be observed, when the outside case is on, no air can come at the fire but what is admitted through the valve (*i*), and the rate of combustion will be accordingly; also, by partially opening the top (*j*) of the fireplace, a considerable quantity of the air admitted into the case will descend through the flue, without coming in contact with the burning fuel. The heat thus communicated to the outside case may be very moderate, while a sufficiently high temperature may be maintained in the inside stove, and also in the chimney, to insure an ascending current that will completely carry away all the noxious products of the combustion. It will be clearly seen, that the principle of this stove consists in enclosing the body of the fireplace with an air-tight case much larger than the fireplace itself, removable at pleasure, and not in contact or connected with it: so it will be of no consequence in what form the inside stove is made, but it may, by modifying its form, be rendered subservient to many domestic and useful purposes.—*William Kirkwood. Edinburgh, July, 1839.*

White's Patent Stoves.—A printed notice respecting these stoves has been

kindly sent us by Mr. M'Nab of the Experimental Garden, Inverleith. Mr. White is an ironmonger in Haddington, and uses these stoves for heating public buildings, dwelling-houses, and plant structures. When Mr. M'Nab called on him, he found one of his stoves in a pit, and another in a vinery; and the general impression on Mr. M'Nab's mind is, that the stove is admirably adapted for horticultural purposes, where coke or cinders can be procured as fuel; for, like Kirkwood's stove, and Arnott's, it will not succeed with any kind of fuel that will run or cake. We have written to Mr. White for a sketch of his stove, and the prices of different sizes; and in the mean time we conclude with the following quotation from Mr. M'Nab's paper.

“Of late years I have visited most of the stoves and green-houses of eminence in this country, where I had an opportunity of witnessing all the varieties of heating by steam, hot water, and flues; and in all the waste of fuel is considerable, notwithstanding that every new method tries to vie with the preceding in saving of fuel. In all, the expense of apparatus is great; and the apparatus is often so complicated, that its management must only be intrusted to very careful individuals; whereas, Mr. White's apparatus is not expensive, and the management can be wholly intrusted to female servants or boys, as there is no possibility of its going wrong, or of the fire going out before all the coke is consumed. The consumption of coke entirely depends on the quantity of air allowed to enter. Large stoves will be found very advantageous to those houses intended for the growth of tropical orchideous plants; and the smaller stoves, from their simplicity and cheapness of fuel, and trifling cost of erection, will be found highly desirable to those individuals wishing small green-houses for their own amusement.” — *J. M'Nab. Edinburgh, Sept. 10. 1839.*

A Carriage Talking-Tube, as a substitute for the common checkstring, is a very great improvement, especially for invalids. It may be described as merely a tubular string, which, by applying the lips at one end, may be spoken through to the coachman, who holds the other end in his hand. It is made chiefly of India rubber, was invented in Paris, and is manufactured in London by Carson and Fink, in Bond Street.

Degradation, as an Element of Punishment. — There appears to me to be an essential, almost obvious, yet much overlooked error, in annexing unnecessary degradation to punishment, which cannot be too strongly pointed out and deprecated. It is vice that degrades; and though punishment, as presupposing past vice and present subjection, is, by the prejudices rather than the reason of mankind, considered degrading also; yet, being of the nature of an atonement, it ought not, abstractly, to wear this aspect (any more than the payment of a just debt, or other compensation for wrong inflicted); and in the case of our children, and others in whom we are really interested, it does not wear it; the natural impulse and principle of kind and judicious parents being not to aggravate the infliction of punishment by disdain, but, on the contrary, to prove, by concurring care and kindness, that it is awarded on principle, and not in passion. (*Australiana*, by Capt. Maconochie.) Thanks to the enlightened and benevolent individual who gave utterance to this sentiment, the mere hearing of which does the heart good. Would that it were universally believed and acted on, not only in the case of governments and their subjects, but in that of masters and servants or apprentices. — *Cond.*

ART. II. Foreign Notices.

RUSSIA.

CRONSTADT, October, 1839. — How often do I muse, recollecting your beautiful gardens in England, which hardly acknowledge the chilling blasts of winter; whose evergreens cheat one into the idea of eternal spring! How different here! My trees have lost almost all their leaves; all my hardiest vegetables are crowded into the back of my green-houses; my broccoli packed

together to be roofed with mats against the snow, and all around me wearing the appearance of desolation. In two or three weeks the ground will put on its white livery, and we shall not behold the face of the earth till the middle of April. Thus gardening is much more difficult with us than in your far happier climate; for every thing tender here, if not housed, is destroyed during the winter, and, when the sun resumes its vigour, all bursts upon us like thought.

I have been much struck by a letter published in the Russian papers, by a retired officer residing on his estates, stating that a peasant in his neighbourhood cured the hydrophobia, but, as always is the case, kept his secret. On getting some of his powders, he found seeds among them which had not been pounded. He sowed them, and produced the *Lôtus ornithopodioides*, which, and similar plants gathered in the fields, he dried, when the seeds ripened, in a cool oven, and then pounded all but the root to powder. He administered a soup-spoonful to man and to the smaller animals, and two to the larger ones. He has cured several of the latter, and one man; and begs the medical people throughout the empire to give the thing a trial, and let him know the result. It is inconceivable how many excellent remedies the peasantry in this country possess, if they were only known. I have two instances among my own relations. A very clever medical man had exhausted every remedy to cure an inveterate ague without success; whereas, a peasant removed the complaint immediately. The other was a man-servant, whose arm, on account of a number of sores, the medical men had condemned to be amputated. As he would not consent, a woman took him in hand, and effected a cure, and his arm is as healthy as mine.

I have not time to go through the remedies against the black insect on cherry trees [? the slimy grub, *Tenthrèdo céra*si]; but, finding my gardener had neglected them, I got angry, and reflecting that they had moist glutinous jackets, I took handfuls of the dry mould about the trees, dusted them heartily, and they all disappeared. This is an easy way of clearing cherry trees. — *B. C.*

INDIA.

‡ *The Improvement of the Agriculture and Horticulture of India* is now assiduously attended to by the East India Company, who are inviting botanists and cultivators to send seeds of every description of useful plant to the Company's house in London; and who, on their part, are distributing an immense number of seeds of all kinds from different parts of the extensive territory under their government. The superintendence of this department is delegated to Professor Royle; than whom there is not a more liberal-minded, intelligent, and active individual connected with the Society's affairs. — *Cond.*

AUSTRALIA.

Castlereagh Street, Sydney, May 4. 1839. — I rode down to Mr. M'Leay's villa, at Elizabeth Bay (see Vol. XIII. p. 587.), some four or five months ago, and was really never more enchanted with any spot in my life; certainly I do not remember any place, either in Great Britain or Ireland, with which I was so much taken at first sight. After passing along a dull road, in a rough unfinished state, a turning brings you near the house; and you look down on the gardens that decline towards the bay, glimpses of which you catch through the trees; the gardens being relieved by two or three masses of stonework, one a beautiful bridge, and the others, I conclude, the walls of tanks. You then come upon the house, a square building with a dome. The most striking part of the effect here is a lawn extending before the house, without a shrub or flower, and terminating in a dwarf stone wall, slightly curved, and with scroll ends, from which there are steps leading into the gardens below. From this lawn you get an extensive view of the harbour, the view being confined on each side by the foliage of the trees; and, below, a thousand hues of trees and shrubs seem to tempt you to wander into a garden of delicious shade and coolness. The house was in an unfinished state; and all behind it

and on the sides still in the rough. The only perfect parts appeared to be the lawn and garden; indeed, the garden was in a very forward state eleven years ago. It occurred to me, that it was the introduction of the stonework that made this place so striking; aided, perhaps, by the great descent from the house to the water.

You are anxious to be informed of the difference between a villa in the neighbourhood of Sydney and one at Camberwell or Peckham; particularly as to the laying out of the gardens, and the kinds of shrubs and flowers. There is not, to the best of my recollection, any great difference. The laying out is similar; the difference in the flowers, &c., consists in the presence of large luxuriant masses of geraniums [pelargoniums] and roses; and the shrubs are mostly such as have been allowed to remain in the ground since it was in a wild state, mostly casuarinas and banksias. Occasionally the young gums (Eucalypti) are left, and make a pleasant variety in the tree way. There is not much of the cottage style introduced for our villas; they are mostly square houses of two stories. This, I believe, is the most economical form of construction, and consequently adopted by our great folks.

The droughts to which we are so continually subject render abortive all attempts at maintaining a garden in the English style; and point out to me, that stonework, and terraces, and large shady trees, the characteristics of Hindostanee gardens, are more suited to our climate than English lawns and flower-beds. You seem to be labouring under an impression that we are much warmer here than is the fact. Doubtless, when the colony commenced, and before there were any clearings to admit the winds, it was very hot: but the climate has now changed; considerable refrigeration has resulted from the clearings, and now we have fires for six months in the year. I have a fire-place for coals in every room of the house I now reside in in Sydney. The increased refrigeration does not appear to have any effect upon the droughts, which are occasioned by our position, and by the absence of any high mountains. Further to the north, where you would expect more heat and less moisture, they have more rain, and intense frosts on the high lands. In my opinion, neither the Port Philip country nor Australia Felix will by and by be thought half so much of as our northern districts. There is more rain, more elevation, more variety, in a geological point of view, not only in composition but in construction, and all the productions of the tropics may be grown in the neighbourhood of wheat and barley; whilst the elevation of the interior affords ample grazing tracts for sheep, which are not so subject to disease as they are in the south, in consequence of the excessive droughts and cold, and occasionally excessive rains. To the north, a river has been latterly explored at Shoal Bay. This proves to be the largest river, or, rather, salt-water inlet, in the whole colony; being a mile wide for eighty miles up, and deep water, with a magnificent country. We expect that all the wool from Liverpool Plains and that country will now be shipped from this river. — *John Thompson.*

ART. III. Domestic Notices.

ENGLAND.

A SUBSCRIPTION Botanic Garden at Bath may now be considered as fairly established; our correspondent Mr. W. H. Baxter, the son of Mr. Baxter of the Oxford Botanic Garden, author of that excellent work *British Flowering Plants*, being appointed curator. — *Cond.*

Bury St. Edmunds Botanical Library. — A library being indispensable to a botanic garden professing to cultivate the more rare and beautiful plants of recent introduction, and the present mode of publishing periodicals being too expensive and voluminous for individuals, it is proposed to devote a room in the garden (accessible to subscribers only, at 5s. per annum, payable to the curator) for the reception of works already in possession of the superintendent; and to enable him, should a sufficient number of subscribers be obtained, to furnish additional means of practical information, by introducing all the standard publications. — *H. T. Nov. 4. 1839.*

The *Chester Nursery*, containing upwards of 70 acres, was purchased by Messrs. F. and J. Dickson, in 1836; and a correspondent informs us that it is now laid out and arranged in a manner superior to most nurseries in this kingdom. Along the main walks, there are specimen trees and shrubs of all the finer kinds; and so favourable are the soil and situation, and so mild the climate, that the plants scarcely suffered anything from the winter of 1837–8. The number of species and varieties of *Coniferæ* in this nursery exceeds a hundred, of every one of which there is a specimen planted out. — *T. B. Manchester, Dec. 1839.*

Mr. Nichols of Blundestone, as a Landscape-Gardener. — This gentleman, the author of *Village Memoirs*, displayed great taste in laying out grounds. His own residence, Blundestone, near Lowestoft, is mentioned by Gray and others as a remarkably beautiful place, and it was entirely his own creation. Though a clergyman, as well as a man of property, he not only found time to improve his own estate, but, as Mr. Fenn informs us, he “planned the grounds of a great number of gentlemen in his neighbourhood: as Sir Thos. Gooch, Benacre Hall; Sir Edmund Bacon, Raveningham Hall; Sir Thos. Beauchamp, Proctor, Langley Hall; and many others.” — *T. Fenn. Beccles, Oct. 29. 1839.*

Prison Gardening. — In the New Prison, Clerkenwell, one prisoner is employed as a gardener. He cultivates the prison garden, the produce of which is principally for the use of the governor; it also furnishes celery, leeks, and parsley for the prisoners' soup. Other prisoners are occasionally employed to assist the gardener, and for the sake of their health. (*Fourth Report of the Inspectors of the Prisons of the Metropolis*, as quoted in the *Morn. Chron.* Oct. 30.)

English Elms. — We are anxious to draw the attention of nurserymen, and country gentlemen who are planters, to the different varieties of English elm grown in the Canterbury Nursery. These varieties have been described in Vol. XIII. p. 28., and also in our *Arboretum*, vol. iii. p. 1373.; but the elm is such an influential tree in the scenery of every country in which, as in England, it is generally planted, and it is so peculiarly an English tree, that it will bear being brought more than once or twice before our readers. Having to order a collection of these elms from Mr. Masters, for the Derby Arboretum, we requested him to send us specimens of this year's shoots of average length of his different species and varieties, and the following are the measurements :

U'LMUS.	Summer shoot of 1839.			Summer shoot of 1839.	
	ft.	in.		ft.	in.
campéstris <i>Arb. Brit.</i> p. 1375	3	6	montàna	-	-
álba, p. 1375	-	3 10	rugòsa, p. 1398	-	3 6
acutifòlia, p. 1375	-	4 6	màjor, p. 1398	-	4 10
strícta, p. 1375	-	3 6	mínor, p. 1398	-	3 0
virens, p. 1375	-	4 6	péndula, p. 1398	-	2 0
viminàlis, p. 1375	-	3 0	fastigiàta, p. 1399	-	4 0
suberosà vulgaris, p. 1395	-	5 0	críspsa, p. 1399	-	1 6
fòliis variegàtis, p. 1395	-	1 6	glàbra végeta (the Hunting-		
álba, p. 1395	-	2 0	don elm), p. 1404	-	7 0
montàna, p. 1398	-	3 9	màjor, p. 1404	-	4 6
			péndula, p. 1405	-	5 0

The comparative growth of these elms will be displayed in the Derby Arboretum, and, we trust, be the means of the more general introduction in plantations of the more rapid-growing kinds. — *Cond.*

Acer Lobèlii. — This species, though one of the most beautiful of the acers, with a leaf having the fine shining surface of *A. platanoides*, and the texture of *A. obtusatum*, with a striped bark like that of *A. striatum*, is almost unknown in the nurseries. It may be interesting to cultivators to be reminded that there is a large tree of it in the collection at Croome, near Worcester, from which grafts, we should suppose, might be obtained; and in some years it ripens seeds. — *W. Clarke. Croome Park, Oct. 12. 1839.*

A'cer créticum.—If any doubt exists in the mind of any person, that this species is the same as *A. heterophyllum*, they may satisfy it at this moment at Syon, and also at Croome. At the former place, the large tree, perhaps the largest and the best grown in the world, has all the leaves on its branches lobed, and those on the suckers rising from the collar of the tree all oblong lanceolate. At Croome the tree has been clipped, and on the upper part of it the leaves are lobed, while, on all the places most cut with the shears, they are oblong, twice or thrice the length of the lobed leaves, and without the least appearance of lobes. — *W. Clarke. Croome Park, Oct. 12. 1839.*

Trees and Shrubs in Croome Park which suffered by the winter of 1837–8. — *Ptèlea trifoliàta*, *Mésipulus canariénsis* [?], *Shephèrdia canadensis*, *Elæagnus argentea*, *Morus papyrifera*, several rhododendrons, azaleas, and andromedas. *A'rbutus Andrâchne* much hurt. *Ligústrum chinense*, 15 ft. high, killed. *Eriobótrya japónica*, against a wall in a warm situation, killed. Many common and Portugal laurels and laurustinuses killed to the ground, and many alive and doing well. All the large cypresses that you so much admired are alive, and looking well. — *Id.*

Heraclèum aspèrrimum.—About two years ago I received from Mr. William Christy three seeds of *Heraclèum aspèrrimum*, which I immediately sowed, and have now a most gigantic plant of it growing in my nursery grounds. Its height is 10 ft. ; the flower stem, which supports several lateral shoots, is 16 in. in circumference, producing 36 umbels of beautiful white flowers, which are now beginning to set their seed. The circumference of the plant at the extremity of its leaves is 60 ft. The whole together forms a magnificent *coup d'œil*, and is strikingly grand. If you think this worth publishing in your valuable Magazine, it is at your service, or if you should wish any of the seeds, I shall be most happy to send you a quantity as soon as they are ripe. — *Bernard Saunders. Sept. 1839.*

We have had *H. aspèrrimum* 12 ft. high, and it has grown 14 ft. high in a moist situation at Bromley Hill. — *Cond.*

New Annuals raised in the Clapton Nursery. — *Eupatòrium odoratissimum Graham*, raised from seeds received from Mr. Morrison, Real del Monte in Mexico, along with seeds of *Sálvia patens*, *Péntstemon gentianòides coccinea*, and many other good-looking plants, which have not yet flowered. A new *Trachymène* [*Didiscus*], and a new and curious *Lobèlia*, both raised from seeds sent direct to us from the Swan River by Mr. Drummond. The *Trachymène* is a very beautiful plant, only differing from *T. cærùlea* in its colour, which is pink ; and if sown early in the spring on a slight hot-bed, and planted out in May, it will make a fine addition to our border annuals. — *H. L. Clapton Nursery, Nov. 23. 1839.*

Rhodánthe Manglèsii.—A specimen was presented to us by Captain Mangles, about 18 in. high by 14 in. broad, with above a 1000 flowers expanded, and twice as many in the bud. The plant was brought to this extraordinary size by Mr. Goode, foreman to Mr. Henderson, of the Pine-apple Nursery, Edgware Road. The seeds were sown April 5, in peat, with a little loam, in pots. In May, the plants were transplanted, while in the seed-leaf, and they were subsequently shifted six different times till about the middle of August : they were in No. 16 pots (6 in. across), and in the degree of perfection mentioned. The *Rhodánthe Manglèsii* has a great tendency to grow upwards without extending in breadth, but this is counteracted by frequent transplanting, so as never to allow the roots completely to fill the pot. (See *Ladies' Flow. Gard.*, p.199.)

Roses in November.—A correspondent informs us that one of the best shows of roses which he has ever seen in autumn was this year growing in Messrs. Lane's Nursery, at Great Berkhamstead, where they continued producing their flowers contemporaneously with dahlias, till they were destroyed by frost. We ourselves saw nearly 50 varieties of roses from the above nursery, exhibited at the Horticultural Society's rooms in Regent Street on November 3. ; many of them were large and showy, the colours chiefly red and scarlet, or red and purple, and some of them were very fragrant. — *Cond.*

The Bokhara Clover.—Mr. Gorrie, jun., took a specimen to the Highland and Agricultural Society's show, at Inverness, from plants grown by his father, raised from the seeds we sent him. The specimen, Mr. Gorrie, sen., informs us, was about 5½ ft. high, with numerous branches of from 18 in. to 2 ft. in length; the plant having grown unsurrounded by others. It was just coming into flower about the 20th of September. It had numerous thick, strong, white, stringy roots, apparently perennial; leaves longer and narrower, and of a lighter pea-green colour than those of *Melilotus officinalis*. Pods racemose, orbicular, small, 2-seeded. Style persistent; flowers small, white. Stipules lanceolate. From the plant flowering the first year, Mr. Gorrie thinks it cannot be the *M. arborea*. It possesses, he says, an estimable property not common to other melilots; viz., that cattle eat it freely. Should it turn out a perennial, or even a biennial, Mr. Gorrie thinks it may prove useful in alternate husbandry. A patch of plants were eaten readily by cows in the beginning of August, and the second cutting on September 23. was 2 ft. high. — *Cond.*

The Caper is so rare in England, that I cannot help taking notice of it in a particular manner, having myself brought it to perfection in England without the trouble of hot-beds or green-houses, and I believe I was the first that has made the caper familiar to our climate. It is now about four years since my friend Mr. Balle, of Camden House, received some caper seeds from Italy, which I then sowed in the scaffold holes of his garden walls, to imitate, as near as possible, the method of their growth about Toulon, and at the same time put several of the seeds into a hot-bed; the consequence was, that those which were sown in the wall rubbish shot near 6 in. the same summer, and the few that came up in the hot-bed were scarce 3 in. high the first year, although they were housed with the tenderest exotic plants, and those in the walls stood the winter without shelter. The second year those plants in the walls made shoots of a foot in length, while those in the pots hardly added 2 in. to their height. The third year, in April, I cut the shoots of the foregoing summer from the plants that were abroad, leaving only a bud or two of each near the original stem, which, the same summer, made shoots nearly 3 ft. long, to the number of about forty upon each plant, and put out buds for blossoms; but the plants in the pots did not advance above 2 in. In short, the last year, one single plant in the wall had not less than a quart of blossom buds upon it fit to pickle, and the plant perfected some of its fruit. Thus, if the plant be headed down in the spring like a willow, it will every summer make a beautiful bush, and afford as good capers as grow in Italy. (*Bradley's Works of Nature*, 1721, p. 36.)

ART. IV. *Mr. Smith of Monkwood, Ayrshire.*

MR. SMITH is one of the most enthusiastic practical botanists that Scotland can boast of; and, being now 80 years of age, has through unavoidable circumstances been reduced to a state which claims the sympathy of all his friends. Whoever is personally acquainted with the man, will not require another word said in his behalf. To those who are not, we submit the following brief notice, drawn up from a private letter of his friend and neighbour, Mr. Skinner, and from personal knowledge. Mr. Smith is a native of Ayrshire, in which country, after going through the regular routine of an apprentice and journeyman gardener, he went to England in pursuit of professional improvement, and worked at Stow, Syon House, and in several metropolitan nurseries. He was some years superintendant of the London Botanic Gardens, under the celebrated Mr. Curtis, founder and author of the *Botanical Magazine* and *Flora Londinensis*, from whose kindness, when he returned to Ayr in 1784 to commence business as a nurseryman, he received 700 species of hardy plants, which formed the foundation of the first public collection of any note made in Scotland. In 1786, Messrs. Dickson of the Leith Walk Nurseries, Edinburgh, purchased 400 species from him; and many

other British collections are indebted to him for plants which he received from London, or obtained from other sources. A more enthusiastic and disinterested botanist never existed. The sight of a new plant had the power of enchantment over him, and so completely engrossed every feeling of his heart, that pecuniary matters never entered his thoughts. He was unwearied in his instruction and assistance to young gardeners; and, in order to induce the youth of his native country to cultivate the study of botany, he offered in 1828, by advertisement in the Ayr newspapers, to supply any parochial school in Ayrshire with a collection of plants scientifically arranged, to illustrate the *Linnæan System of Botany*, free of expense. This offer, he often regrets, was not accepted or acknowledged, even in a single instance. With all this, the retired habits and extreme modesty and amiability of his character, joined with great cheerfulness, and a degree of enthusiasm that nothing can surpass, endeared him to all with whom he was personally acquainted. We shall never forget the reception which he gave us at Ayr, and at Monkwood, in 1831. Mr. Smith's offer to supply collections of plants to parochial schools, at a time when the idea of having school gardens was quite new in this country, is alone sufficient to hand down his name to posterity, not only as an enlightened, liberal, and most benevolent man, but as one in advance of the age in which he lived. That such a man should suffer in the decline of life, and at the age of 80 years, for want of encouragement, is a most lamentable circumstance, though by no means uncommon. Happily there are men who can sympathise with his condition, and we hope to see a practical proof of this, in such a liberal subscription as will put Mr. Smith and his family, for his future days, beyond the reach of want. The names of subscribers will be received by Mr. Skinner, Ayr; and we know the liberality and kindness of nurserymen sufficiently well, to foresee that they will not only subscribe, but promote the scheme of the committee by every means in their power. Let it be recollected that, in conformity with the advertisement, every subscriber will receive a collection of plants, according to the sum he may subscribe.—*Cond.*

ART. V. *Retrospective Criticism.*

MR. RIVERS'S Roses.—In noticing (p. 10.) that the collection of trees and shrubs for the Derby Arboretum was supplied by Messrs. Whitley and Osborn of Fulham and Mr. Masters of Canterbury, we inadvertently omitted to state that we ordered a miscellaneous collection of roses from Mr. Rivers of Sawbridgeworth, amounting to 100 kinds. These roses form no part of the scientific collection, the genus *Rosa* in that collection being entirely supplied from the Fulham Nursery, but are merely for the purpose of adding to the variety of a miscellaneous border of trees and shrubs, which forms the boundary to the Arboretum, and which is intended to shut out the surrounding buildings. We think this notice due to Mr. Rivers; because, though we shall oppose his *Popular Catalogue of Trees and Shrubs* by every means in our power, we shall, as heretofore, recommend his *Catalogue of Roses* as the best that we know of among the rose catalogues of English nurserymen.—*Cond.*

Storing Carrots for Winter Use.—In Vol. XV. p. 605., Mr. A. Forsyth recommends that carrots should be stowed away for winter use with about an inch of top to each; I beg to say that I have practised the reverse of this mode for a number of years with complete success. Instead of leaving 1 in. of top to each carrot, I have the whole crown cut off, or, as the men term it, cut in to the quick. This prevents the carrots from vegetating in the spring, and thus preserves the saccharine matter, as well as the pure flavour of the carrot, till June, or longer; properties that render carrots, when preserved in this manner, far superior to carrots that are either sown in hot-beds during the spring, or those that have stood out during the winter; neither of which kinds do I ever grow, except in case of a short supply of the others.

I have recommended the same plan to be adopted in stowing Swedish turnips that are intended for spring consumption; and this plan is very much approved of in this neighbourhood; as, when they are brought out of the store in March and April, they will be found to possess all the feeding qualities that they did when stowed away. The only, but very important, thing to be guarded against is, not to allow them to be put too thick together; as in that case they would heat and spoil.

The north side of barns or other buildings is the best situation; as, if even the heaps are exposed to a few sunny days in spring, their sloping sides would absorb sufficient heat to cause the interior mass to commence heating, particularly where the soil is of a dark colour. — *John Pearson. Kinlet, Nov. 5. 1839.*

Mr. Gorrie's Horse-hoe. — In our notice of the Highland Society's transactions at Inverness, as copied from a newspaper (Vol. XV. p. 531.), Mr. Gorrie is said to have received a medal for having invented a new horse-shoe; but that gentleman informs us, that it was not a horse-shoe, but the model of a horse-hoe, for which he received the medal. — *A. G. Sept. 24. 1839.*

ART. VI. *Queries and Answers.*

Syon House Gardens. — From your having, in the *Arboretum Britannicum*, given figures and descriptions of so many trees growing at Syon, you must necessarily be well acquainted with the gardens and grounds of that celebrated place; and, as these are not shown to the public, I, in common with a number of your readers, should feel greatly obliged if you would publish some account of them in your Magazine. By some who have seen them, they are described as a model of good taste and high keeping; and by others, the trees are said to be crowded together, and the more rare kinds greatly injured by the commoner sorts. The rockwork, also, is much talked of; but above all the magnificent conservatories. We should all much like, and probably we should be greatly instructed by, your opinions on these matters; for though we cannot see Syon, there is no reason that I know of, why we should not hear of it, and profit from what we hear whether it be good or bad. — *James Allen. London, Dec. 6. 1839.*

Roughead's Swedish Turnip. — Mr. Roughead, seedsman, Haddington, informs us, that he has paid great attention to the selection of his variety of Swedish turnip for the last ten years, and been always successful in preserving the variety pure, till lately; when a ninth part of the plants showed the appearance of rape in their foliage; the bulb not swelling as in that variety. He wishes to be informed of the probable cause of the degeneracy, seeing that he bestowed the usual care in selecting the roots for the seed, and in planting them at what he found, from experience, to be a sufficient distance from all other plants of the *Brassica* tribe. — *D. R. Haddington, September 11. 1839.*

ART. VII. *Obituary.*

ALLAN CUNNINGHAM, the colonial botanist at Sydney, died there on the 27th of June. His death was in consequence of a series of colds caught during the rainy season, in his last unfortunate travels in New Zealand. A biographical notice of Mr. Cunningham will be found in the *Athenæum* of Dec. 14., and a short notice in the *Literary Gazette* of the same date; but a much more complete biography will shortly be prepared, which it will be our melancholy duty to lay before our readers. — *Cond.*

THE
GARDENER'S MAGAZINE,
FEBRUARY, 1840.

ORIGINAL COMMUNICATIONS.

ART. I. *Descriptive Notices of select Suburban Residences, with Remarks on each; intended to illustrate the Principles and Practice of Landscape-Gardening.* By the CONDUCTOR.

No. 14. FORTIS GREEN, MUSWELL HILL, THE VILLA OF
W. A. NESFIELD, ESQ.

“A happy rural seat, of various view.” — *Milton.*

MR. NESFIELD has long been well known as a landscape-painter of eminence, and as connected with the Society of Painters in Water-Colours. He has lately directed his attention to landscape-gardening, and that with so much success, that his opinion is now sought for by gentlemen of taste in every part of the country. His own villa at Finchley is in a singularly rural peaceful situation, rarely to be met with so near London: it is laid out with appropriate taste, and the grass field, forming part of it, is managed in such a manner as actually to be a source of profit. We were so much gratified with the appearance of this villa, and with Mr. Nesfield's sheep-farming, that we prevailed upon him to favour us with a plan and some sketches of the former, and with an account of his mode of managing the latter, which he has very kindly done, and we now lay these before our readers. [This article was prepared, and set up in type, for our *Suburban Gardener*, in the summer of 1838, but the engravings were not ready in time to admit of its publication in that work.]

Fig. 13. in p. 56. is a view of the entrance-front of this villa, the ground occupied by which consists of two portions, represented in *figs. 8.* and *9.* The narrow portion, next the public road, shown in *fig. 8.*, contains the approach, the house, the kitchen-garden, and the flower-garden; and the wider portion (*fig. 9.*) shows the paddock, or sheep pasture. The whole lies on a gentle declivity, facing the south; the farther extremity of the field being probably 50 ft. below the level of the road, at the entrance-gate at 1, in *fig. 8.*

In *fig. 8.*, the ground plan of the narrow part of Mr. Nesfield's grounds, are the following details, furnished by Mr. Nesfield:—

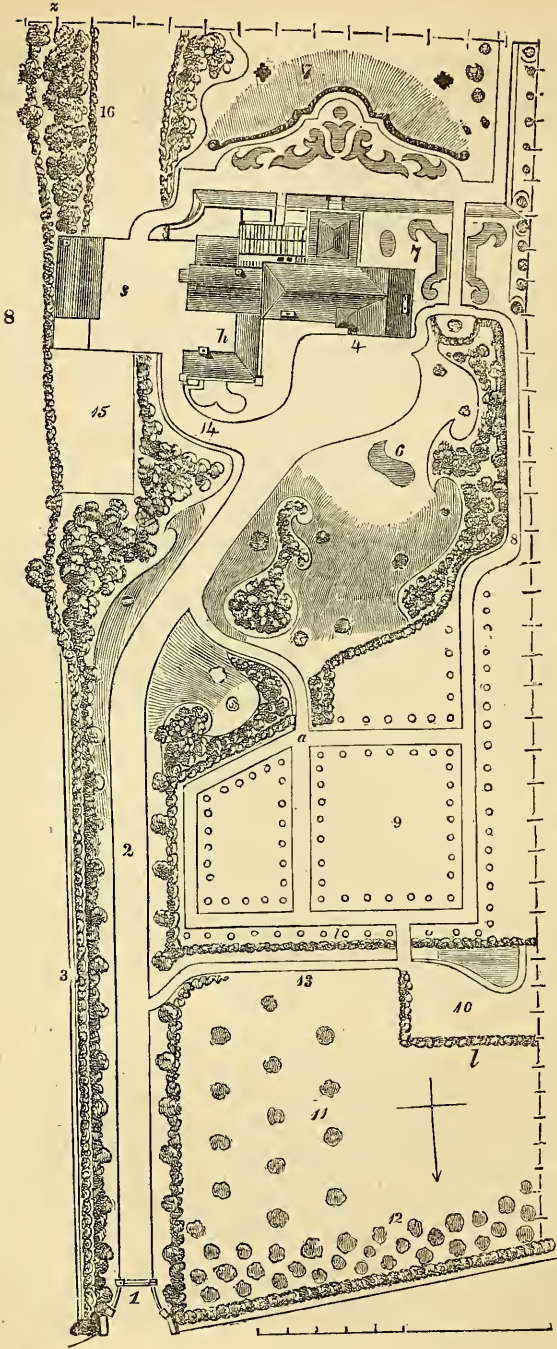

Plan of the Grounds at Fortis Green.

This sketch represents the narrow portion next the public road. Fig. 9, in p. 51, is a continuation of the plan; and, had our space permitted, should have crossed the present page at the top, uniting the shrubbery 16 at 2.

1, Entrance by a close gate, 6 ft. 6 in. high.

2, Avenue of sycamores, bounded on each side by a laurel hedge cut nearly perpendicular, like a clipped hedge, and allowed to be high enough to screen the kitchen-garden, &c. There are other laurel hedges in the kitchen-garden marked *l*.

3, Boundary, consisting of a quick fence and ditch.

4, Entrance front of the house.

5, Lawn, which descends very rapidly to the flat surface upon which is placed the house. In consequence of the frontage being so long and narrow, it was impossible to place the house upon the level (i. e. where the lawn is separated from the kitchen-garden), because the south view, which is extremely desirable, would have been contracted to nearly half the width which is now seen; and, as the kitchen-garden and other requisites would have destroyed the character of the view from the south, which now in itself assumes the appearance of a park-like field, there was no alternative, but that of adopting the different sites indicated on the plan, for the lower flower-garden, kitchen-garden, &c.; particularly as there is no view northwards. The objection, therefore, of descending to the carriage-sweep in front of the house, is accounted for.

6, Dug ground, containing a variety of ornamental trees and shrubs, the margins are devoted to low flowering shrubs, &c.

7, Flower-garden, upon two levels.

8, Walk connecting the kitchen-garden with the flower-garden, along a row of lime trees.

9, Kitchen-garden, having a holly hedge from the gardener's entrance (*a*) to the yew hedge near the corner of the house (*b*); the remaining hedges are all common laurel.



Portion of the Grounds at Fortis Green.
This cut should cross the top of page 52, joining fig. 8. at *

- 10, Melon ground and pond.
 11, Orchard, and potato and mangold wurzel ground, &c.
 12, Belt of spruce and Scotch firs.
 13, Gardener's communication with the public road, when manure and other materials for the gardens are wanted to be brought in.
 14, Approach to the stable-yard.
 15, Grass drying-ground, on a lower level than the approach, and screened by a dense mass of evergreens, &c.
h, House-yard. *s*, Stable-yard.
 16, in *figs.* 8. and 9., Boundary plantation, fenced towards the field with furze (kept clipped), concealing from the flower-garden a sheep-hut and little stack-yard (*x*).
 17, in *fig.* 9., Groups of thorns and other trees.

The frontage of the villa adjoining Mr. Nesfield's at *c* in *fig.* 10. is the same size as his own; and, as both places were built by the same architect (A. Salvin, Esq., Mr. Nesfield's brother-in-law), and laid out at the same time, care was taken that where the ground was planted thickly in one villa, it was planted thinly in the other, and *vice versa*; so that each villa might aid the other in producing its general effect, and in sacrificing as little ground as possible in planting.

The field belonging to Mr. Nesfield embraces the frontage of both houses; and the land attached to both, being $8\frac{1}{4}$ acres, is subdivided as shown in *fig.* 10. In this figure, *a b* show the land occupied by Mr. Nesfield, and containing in all $4\frac{1}{4}$ acres, *a* being that part which comprises the house, kitchen-garden, &c., and *b* being the grass field; *c* is the house and garden of the adjoining occupier; and *d* his grass field, to which he has access by the road *e*; *f* is the public road, and *g g* are the entrance-gates to the two houses. This arrangement (on purchasing the land) was made in order that each house might enjoy the effect of space as much as possible, and, by dividing the ground with the wire fence (*h*), which is scarcely visible from either house, the breadth of effect is not cut up, as it would have been, had the division been made longitudinally. The boundary hedge (*i*) winds considerably, and there are several very fine trees in it, which, in consequence of the winding, group most admirably, as shown in the view, *fig.* 11. The wood at *k*, in *fig.* 10., belongs to the Earl of Mansfield's grounds, at Kenwood, and, together with the spire of Highgate church, adds greatly to the beauty of the landscape, as shown in the view above referred to (*fig.* 12.).

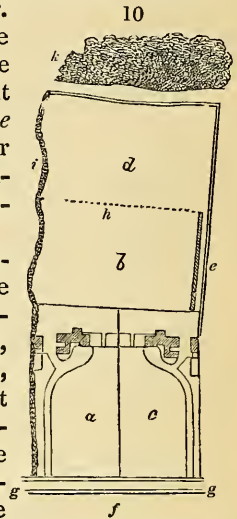

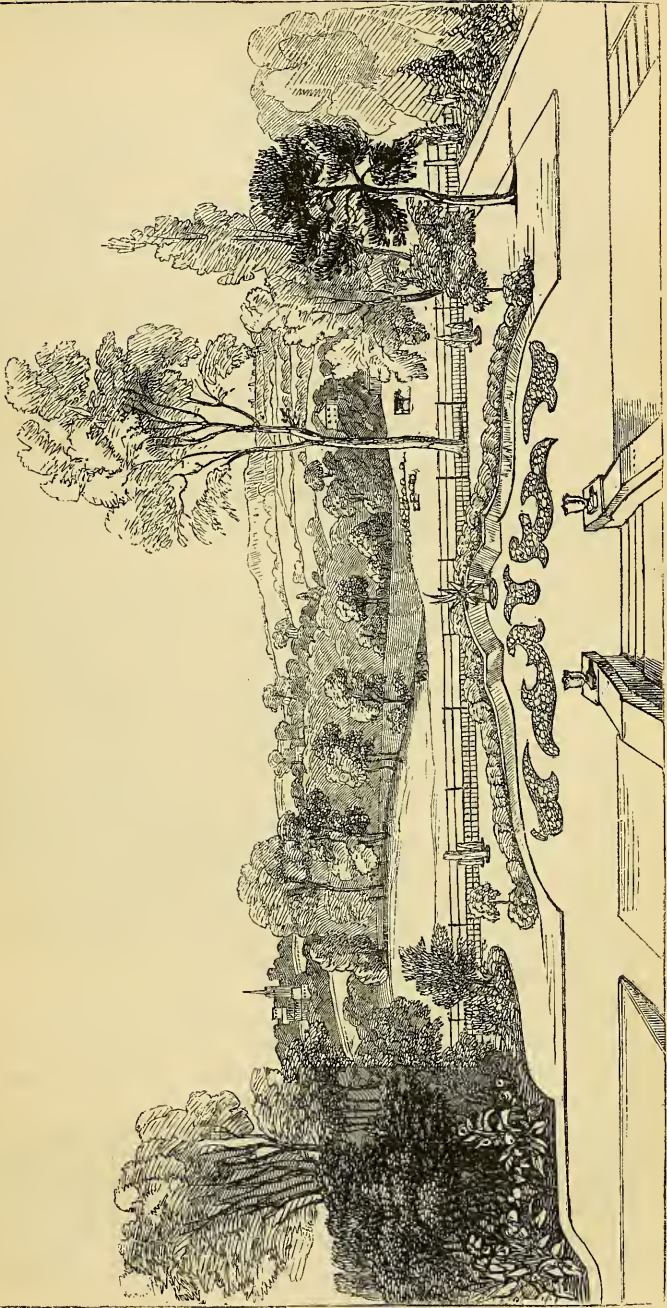

View from the Lawn Front of Fortis Green.

Fig. 12. is a ground plan of Mr. Nesfield's house and flower-garden on a larger scale.

a, Drawing-room. *aa*, Green-house. *b*, Dining-room.
c, Passage. *d*, Staircase. *e*, Porch. *f*, Closet.
g, Way to cellar, from kitchen and glass closet. *h*, Kitchen.
i, Scullery. *k*, Stairs to servants' rooms. *l*, Laundry.
m, Store-room. *n*, Tool-house, at the end of which is the stoke-hole to the green-house. *o*, Passage to the yard. *p*, Larder.
q, Coal-hole. *r*, Wash-house. *s*, Pump. *t*, Yard.
u, Stable. *uu*, Dung-pit. *v*, Walk from the entrance-front to the flower-garden.

w, Walk connecting the kitchen-garden with the flower-garden.

x, Gate in the wire fence which separates the flower-garden from the field.

y, Entrance to the field, from a small paddock communicating with the stable-yard.

z, Shrubbery, and boundary fence.

1, Steps from the drawing-room. 2, Beds for low flowers, on gravel, and edged with box. 3, Aloe-tub.

4, A mound, raised 18 in., having its interior slope as steep as it will stand (that is, with a base of 2 ft.). Upon the top is a hedge of dwarf China roses, jasmines, and sweetbriars, kept 18 in. high, and terminating in each end in a small circle, out of the centre of which rises a standard rose tree. The exterior slope, as indicated by the shading, is long, and gradually diminishes, like a glacis, till it imperceptibly unites with the common level.

5, Beds for groups of dahlias on grass, the highest plants being in the middle of the beds.

6, Dug border, in front of a plantation of evergreens and low deciduous flowering trees, for high and low perennials, and annual flowers.

7, Dug borders for perennials, annuals, &c., and plants out of the green-house.

8, Dug borders for low flowers, all upon grass. The two conical trees shown at the steps, are arbor vitæ.

9, Dug borders, on grass, for high flowers, &c. Next to the palings are various deciduous trees and evergreen shrubs; and the palings are covered with common laurels, trained like fruit trees. This paling is of common Baltic deal, Kyanised, but not painted, and it appears to stand very well.

10, Mulberry tree.

11, Yew hedge, to separate the flower-garden from the entrance-front.

12, Sloping bank of turf, having a rise of 3 ft. on a base of 7 ft. This slope was formed in consequence of the house standing on an inclined plane.

The house now has the effect of standing on a horizontal platform.

13, Steps leading from the lower to the upper flower-garden.

14, Wall to the offices, which containing no windows is covered with peach, nectarine, and apricot trees. Flowering creepers might be substituted; or it might be treated as a conservative wall, and covered with myrtles, camellias, oleanders, fuchsias, &c.

Management of the Grass Field. The total quantity of land at Fortis Green is $4\frac{1}{4}$ acres, of which $1\frac{1}{4}$ acre is occupied by the house, pleasure-ground, kitchen-garden, shrubberies, &c., and 3 acres are exclusively devoted to sheep.

There are two modes of stocking a farm with sheep upon a small scale.

First Method. Buy in September, or in the beginning of October, three ewes in lamb, per acre, at 25s. each, which will, on an average, produce four lambs an acre, in February (though there are frequently five or six). These lambs will be fat in

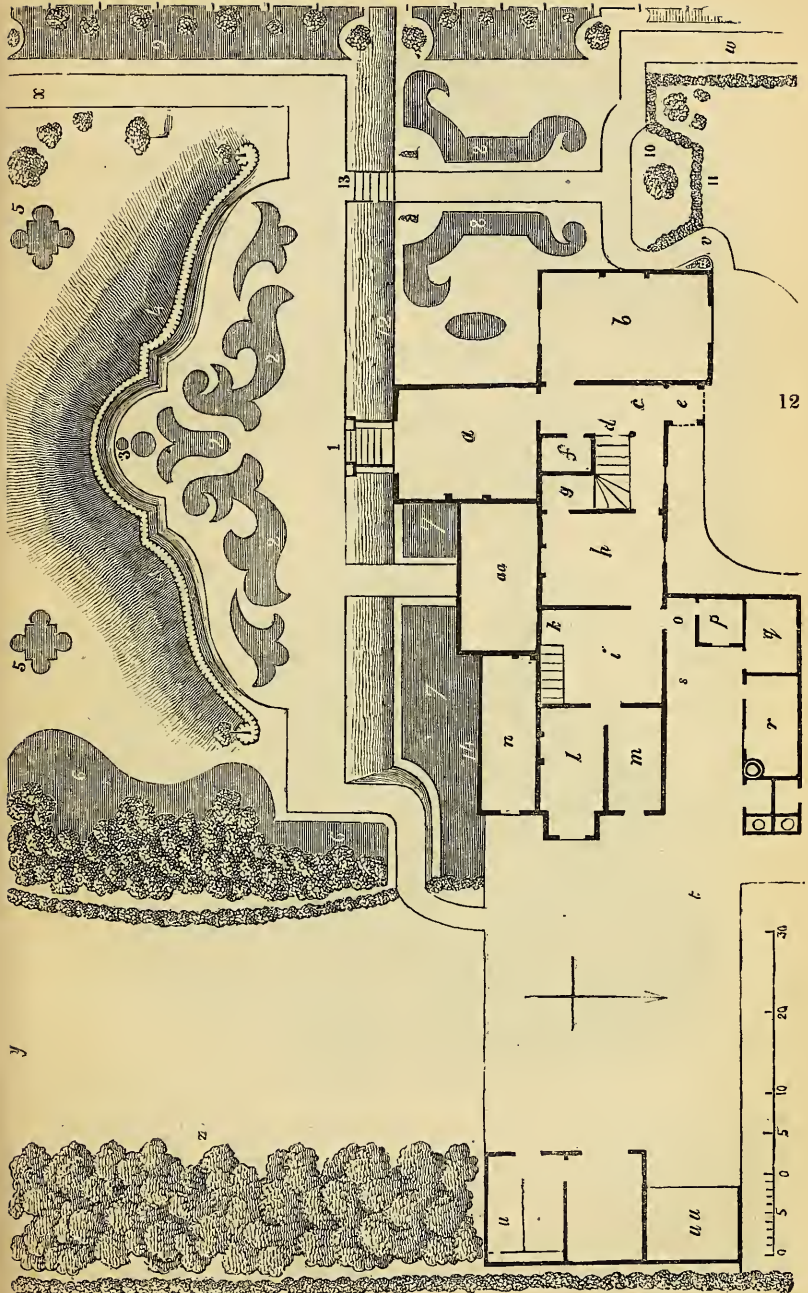

E 4

13

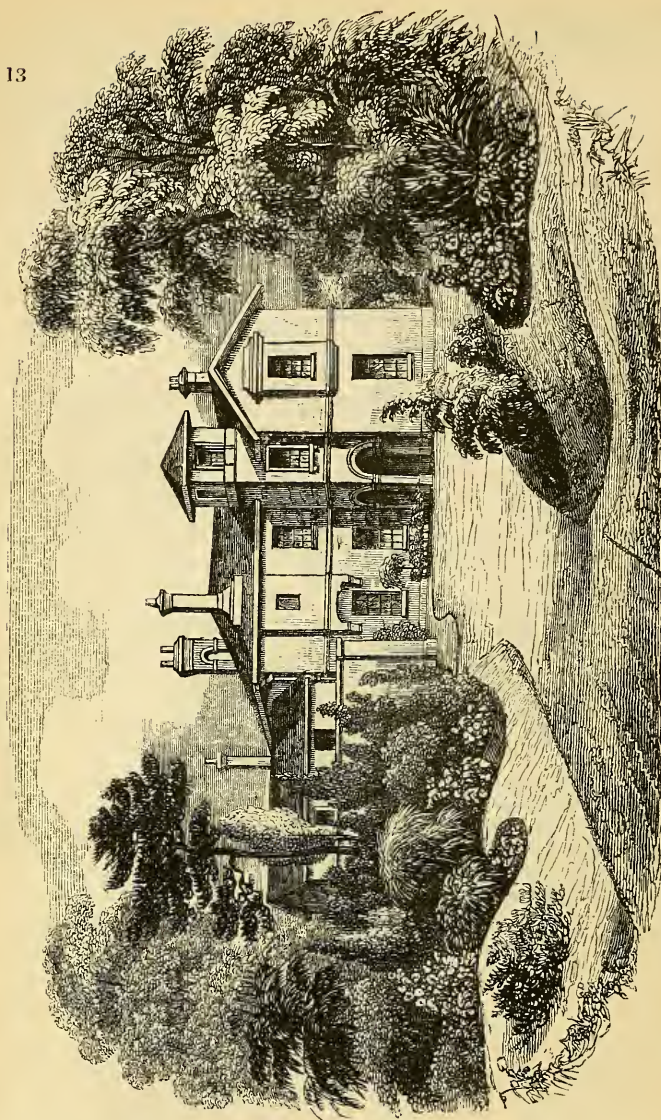
*Entrance Front of Fortis Green.*

May, or early in June, and will sell for 27s. each. The fleece of each ewe will weigh about 4 lb., and will sell for 1s. per lb.; and, nine or ten weeks after the lambs are gone, the ewes themselves will sell for 30s. each. This is a fair average, if the season is mild; but, as that cannot always be reckoned upon, it is prudent to grow mangold wurzel or Swedish turnips in some corner

of the garden, which, with a truss of hay (rowens) to each sheep, will provide for the winter, when the ground is covered with snow; and thus the ewes will be kept in good condition, and be better prepared to afford milk for the lambing season. Spare Brussels sprouts and Scotch kale are very useful to give to the ewes after lambing, as they are extremely productive of milk, but *too much* is apt to induce rot, therefore caution is required.

The account on this first mode will therefore run thus:—

	£	s.	d.
Four lambs, at 27s. each	5	8	0
Wool of three ewes, 4s. each fleece	0	12	0
Profit upon three ewes, at 5s. each	0	15	0
	<hr/>		
	6	15	0
Deduct			
Clipping and washing, 6d. per head	0	1	6
Hay, one truss per head, at 2s. 6d.	0	7	6
Salesman's commission and driving, 7d. per head	0	1	9
	<hr/>		
	0	10	9
	<hr/>		
Clear profit per acre	6	4	3
Acres	-	-	3
	<hr/>		
	£18	12	9

Second Method. This is rather more profitable, with less risk in lambing, and also with less consumption of winter food. It consists in buying in autumn, as above, only two ewes per acre. The fair way, however, of reckoning upon this plan will be best made upon the three acres, because six ewes will, upon the average, produce 8 lambs, which are not divisible by three, without a fraction. Then, in March, buy eight tegs (that is the last year's late lambs), at 25s. each, the wool of which is more valuable than that of ewes by 3s. per fleece. The tegs will sell in autumn for 36s. per head.

The account upon this second method runs thus:—

	£	s.	d.
Eight lambs, at 27s. each	10	16	0
Wool of six ewes, at 4s. each	1	4	0
Profit upon the six ewes, at 5s.	1	10	0
Wool of eight tegs, at 6s. per fleece	2	8	0
Profit upon eight tegs, at 11s.	4	8	0
	<hr/>		
	20	6	0
Deduct			
Hay for six ewes, at 2s. 6d.	0	15	0
Clipping for 14 ewes and tegs, 6d.	0	7	0
Salesman's commission and driving, 7d. per head for 14	0	8	2
	<hr/>		
	1	10	2
	<hr/>		
Clear profit upon three acres	£18	15	10

Of course an inexperienced person should employ a respectable

salesman in Smithfield, who will always be able to supply, when wanted, at about the above prices, though sometimes ewes are bought for 23s. each; and, if not convenient to the owner of the land to sell to his own butcher, the same salesman will sell them at 6d. per head commission, which is not deducted in the above accounts, because it can seldom happen that a butcher who is dealt with the year round will refuse to buy and give credit against his account.

The above modes of stocking apply only to good land in the neighbourhood of London, particularly if it is dry and has sweet herbage.

In the spring, when there is a prospect of a very abundant supply of grass, the three acres may carry nine tegs, if the ewes and lambs are in capital condition; overstocking, however, even with one head, is hazardous. On a small scale, like that in question, it is very desirable to divide the land by hurdles, so that the stock may be changed every ten days; since nothing advances sheep more rapidly than a "fresh bite," and the grass by this means is also less wasted.

Sometimes six ewes in eight will have twins; and an instance even more prolific than this occurred this season in a paddock on Muswell Hill, where four Leicester ewes produced eight lambs, which sold for 27s. each.

	£	s.	d.
Hence, eight lambs, at 27s. - - - - -	10	16	0
Wool of four ewes, at 4s. - - - - -	0	16	0
Profit on four ewes, at 5s. - - - - -	1	0	0
	12 12 0		
Deduct			
Hay, 2s. 6d. - - - - -	0	10	0
Clipping, &c., 6d. - - - - -	0	2	0
Commission, &c., 7d. - - - - -	0	2	4
	0 14 4		
Clear profit from 4 ewes - - - - -	£	11	17 8

Should there be more mangold wurzel or Swedes grown than are wanted, the overplus is always extremely saleable to cow-keepers, the former from 2l. to 3l. per ton, according to the abundance or scarcity of turnips.

Sheep are kept at Fortis Green, in preference to a cow, because the family is small, and, the neighbourhood abounding in farms, the supply of milk and butter is cheaper than were it the produce of the three acres, considering the constant attendance, risk, and trouble, incidental to cow-keeping; whereas sheep are very ornamental, and give no trouble worth naming.

Fortis Green, Muswell Hill.

ART. II. *The Derby Arboretum, and probable Influence of Mr. Strutt's Example; with some Remarks on the Advantages that would result from uniting Horticulture with Botany in Public Gardens.*
By W.

MR. STRUTT has made a munificent gift to the people of Derby, and there are two reasons for supposing that his liberality will not be thrown away. In the first place, you, Sir, have the laying out of the grounds, which will therefore become a model for all similar localities. Secondly, I hear that Mr. Strutt has made it an imperative condition that the garden shall be open to the public two days in the week, one of which is Sunday. If this is true, the artisans of Derby will enjoy a rare opportunity of expanding their minds by the contemplation of nature, and of refining and cultivating their taste by frequent observation of the noblest combinations of artistical gardening. That such an institution, thus auspiciously commenced, may be adequately supported, must be the ardent wish of every friend to popular improvement. For my own part, I confess I would rather that a town should never undertake or commence a public garden, than carelessly, ignorantly, or indolently, suffer it, when once completed, to go to decay. Such, I much fear, will be the fate of the noble and, in some respects, unparalleled Botanical Garden of Sheffield, upon which, in a late Number, you bestowed high and well-deserved commendation. Should that be the case, the fault will certainly not be with the working classes, who have as yet not been allowed to contribute towards its support; for, to a mechanic, the payment of a shilling, and exclusion on Sunday, the only day on which he has leisure for the contemplation of nature, form a violent prohibition against entering its precincts. At present the funds are very low, so low indeed that I hear it is doubtful how much longer they will suffice to keep the garden open. Evidently, then, the wealthier and middle classes of Sheffield are apathetic; they know not the value of the jewel which has fallen into their keeping. Such is but too generally the case with the inhabitants of our commercial towns; they toil all their lives for wealth, which, when accumulated, they know not how to enjoy. But why not allow the working classes an opportunity of one day in the week breathing a pure atmosphere, while they contemplate the wild grandeur of the Hallamshire hills, or gaze with wonder on the products of distant lands? Why not open the garden on a Sunday at a moderate charge? Alas! clerical bigotry forbids this simple, obvious, and effective means of recruiting the dwindled funds of the institution. The glories of nature are doomed to be a sealed book on the Sabbath, while the doors of the alehouse are left open to invite the listless passer-by. Thus are men debarred from rational and elevating

employment of their faculties, cut off from the influences which would humanise and civilise them, actually driven into temptation, forced into vicious courses, then lectured on the exceeding depravity of their nature, and punished for the commission of crimes which, under other circumstances, they might have abhorred. It is said that many clergymen are shareholders in the garden, and that it is owing to their votes or influence that it is closed on Sunday. I most sincerely hope that the reverend gentlemen will be so severely mulcted by their own foolish policy, worthy only of the dark ages or of a savage country, that in the course of time more enlightened notions may penetrate their crania through the medium of their pockets.

I am straying however, though not very widely, from the more immediate object of this letter, which was to suggest, with all due deference to your superior knowledge and experience, an addition to the usual contents of a botanical garden. I am inclined to think that, if hot-houses, and the fruit department in general, formed a part of the plan, the garden would be much more efficiently supported than those establishments usually are. In a manufacturing town, there is only a small minority who can be brought to perceive the use of any thing which does not either help to put money into their pockets, or to procure some palpable pleasure of the senses. That science (except the department which invents spinning-jennies) or art should be included in the category of the useful, utterly passes their comprehension, for they have yet to learn that the use of all created existences is to form, expand, and elevate the mind of man. To such men, botany seems as useless as astrology, and a collection of ferns or Orchidaceæ as little to be prized as an assortment of weeds. But it will be found to be far otherwise with fruit; there are few palates so obtuse as to be insensible to the charms of the perfumed grape, or not to prize the melting and the juicy peach. Many there are, therefore, who would encourage the cultivation of fruit, who would think themselves mad were they to give a single shilling towards a mere botanical garden. I am not sure whether a compliance with my suggestion might not even double the number of subscribers.

I think, too, the plan would be useful for other reasons. If both the forcing department and the management of the walls, were, as they ought to be, scientifically attended to, they would form at once a school for the young men employed on the premises*, and a model which all gardeners in the neighbourhood might advantageously and with confidence consult. Secondly, an opportunity would be afforded of studying the varieties of

* By the way, might not a horticultural school be advantageously appended, by taking, on the payment of a premium, other young men besides those absolutely necessary to keep the grounds in order?

each fruit tree, of classifying and ascertaining the qualities of those already known, of introducing new varieties; and, lastly, of reducing into order the apparently impenetrable chaos of synonymes, which presents so formidable an obstacle to the successful cultivation of this department of horticulture.

In your *Encyclopædia of Gardening* you allude to the imperfect knowledge possessed of the varieties of the vine. Now, it appears to me, that, if those places where botanical gardens are established would generally attend to this subject, and communicate with each other and with the Horticultural Society of London, much might be done to clear up all such difficulties. Thirdly, besides increasing our actual knowledge, this plan would greatly facilitate the diffusion of new and superior varieties. Although the practice of forcing has of late years become much more general than formerly, and few gardens are now without glass, it is to be feared that the quality of the fruit has by no means kept pace with the quantity. In grapes, especially, most people in limited establishments seem to content themselves with Black Hamburg, and one or two of the commoner white sorts. One of the principal reasons why rare and valuable kinds are not more commonly cultivated is, undoubtedly, the difficulty of procuring them genuine from country nurseries. Their lists abound, it is true, in names, but their grounds are miserably defective in the reality; and certainly nothing can be more disheartening to a purchaser, than, after having paid a high price for pretended choice sorts, and after having watched them for years with anxious care, to find that both his money and his pains have been thrown away upon either common or worthless varieties. On a small scale, this has happened to me. A Cannon Hall turns out a Black Hamburg, a Black Lombardy the same; some apricots purchased for Moor Park are Brussels, and a Ribston Pippin is some other unknown sort. A gentleman in this neighbourhood, of great horticultural skill, has for years been making a collection of choice plums, but he has long given up applying to the nurserymen, finding, as he says, that they always send him something, which, though dignified with the appropriate name, partakes of the qualities of the sloe and the damson. His plan is, whenever he meets with fruit of which he approves, to get grafts, and transfer them to his garden. In this manner he has succeeded in procuring the *Impératrice*, from a noble tree at Darnington, which annually produces abundant crops. But, although this method may with advantage be followed by those who have great horticultural zeal and skill, it is evidently unsuited for persons who wish to attain the same results with less trouble, and in a shorter time. If, however, at Liverpool, Birmingham, Sheffield, Derby, and all other botanical gardens, there were extensive depôts of all the most

approved varieties of fruit, kept in pots, for the convenience of customers, both nurserymen and proprietors of gardens would have an opportunity of procuring them at pleasure, and with full confidence in their being genuine. Or it might be found more convenient for one garden to confine itself to grapes, while another took peaches, a third hardy wall fruit, &c. As to expense, I can hardly anticipate any material addition, for the sale of fruit and young trees would evidently repay a part, at least, of their culture, while it is also possible that the subscriptions might be so much increased as to leave a profit. The example set to the nurserymen of precision and care in the selection of the sorts, would be an important lesson to them, and of no small service to the conduct of their business. It is a common complaint among these gentlemen, I understand, that small encouragement is shown to them, except to a few of the most celebrated in the vicinity of the metropolis. If so, it must be their own fault. Let them show a good article, and they will be certain to find plenty of customers. When a nurseryman once establishes a high name, he has always more orders than he can execute. But, as the public become enlightened, they grow more and more intolerant of Peter Pindar's razors, made to sell, not to shave. In short, the dealer in fruit trees will find it his best policy to imitate the industry of the dealer in florist's flowers, and in ornamental plants in general.

I cannot conclude this long, and I fear tedious, letter, without adverting to the subject of agricultural seeds. To obtain in their highest perfection every plant used in agriculture is evidently an object of the first importance. How much yet remains to be done, even in vegetables the most extensively cultivated, is demonstrated by Colonel Le Couteur's experiments on wheat. That enterprising and skilful agriculturist has proved that not only the produce per acre, but the quality and quantity of flour to be obtained from a given portion of wheat, are influenced, to a degree almost incredible, by the purity of the seed; that is, by its being of superior quality, and of one and the same kind. He has also shown, in a masterly and satisfactory manner, the essential differences in yield, straw, quality, &c., among several varieties not usually known. Now, there can be no doubt, that, were the same process pursued with other vegetables, similar results would be obtained; and we should find that our commonly cultivated varieties of almost every field plant might be improved to an almost indefinite extent. Nothing would give me greater pleasure than if you, or any of your correspondents, would suggest some plan of effectually preserving the labours of such men as Colonel Le Couteur, and also of imitating his efforts by applying similar means to other vegetables. The problem seems to be, "How is pure

seed of the best varieties of known plants, as well as of species yet untried, to be produced with certainty, and on a scale adapted to the wants of the farmer?" It is from the art of horticulture, rather than from that of agriculture, that any such improvement will probably emanate. Messrs. Lawson have already furnished an important contribution, but who will continue their labours, by continuing to experiment on the most important plants in the *Manual*?

Near Doncaster, Dec., 1839.

ART. III. *Observations on the present Appearance and Prospects of Gardening in the Canadas.* By ALEXANDER GORDON.

HAVING occasionally troubled you with some passing remarks on the state of gardening in the United States of America, I now send you some observations on the present appearances and prospects of horticulture in the Canadas. In the years 1833 and 1834 I lived in the upper province, yet my sphere of observation was too limited to warrant my then attempting anything like a general statement; but, during the past summer, I have traversed the provinces to the extent of from 1000 to 1200 miles, and I believe my tour included all those places where gardening has received any attention, further than the planting of an orchard, or growing a few culinary vegetables.

My tour in the Canadas commenced at the justly celebrated Falls of Niagara, and thence to the city of Toronto. From Toronto I explored the country on to Hamilton, and from the latter place I traversed the shores of Lake Erie, and ultimately on to Lake Huron. From Lake Huron I returned to Toronto, but by a different route; and from that city I continued my journey on to Montreal, diverging, of course, very considerably from any given route. During this wide range, I believe I embraced almost every town or village of any importance. You will perceive that in the following remarks it frequently occurs, that a large tract of country is passed over without receiving even the slightest notice; the cause is obvious. The duties imposed on settlers in a new country are very multifarious; and absolute necessities must naturally give precedence to every other consideration. The clearing of lands occupies considerable time; and, even when there is a latent taste for the art, gardening will naturally be nearly, if not entirely, neglected, except so far as its productions are subservient to some useful purpose. But when the harassing fatigues of a new settlement are, in some measure, overcome, then the man of refined taste will follow the natural bent of his inclinations; and, in the soil where grew the sturdy oak, there the fragrant rose, the gay lily, and the showy tulip will display their beauties, and exhale their fragrance around. The former wilds will display the ornamented parterre, and the corduroy roads must yield to gravel walks. Still, these metamorphoses, as I before remarked, must be the result of time; and, as much of my tour was through a country which has been but very recently a desert wild, the barrenness of gardens will be easily accounted for.

I shall commence my observations at Lake Huron, but, for a considerable tract of the most fertile country in the provinces, I am sorry to say my field is narrow, nay, in fact, without a single place worthy of even a passing notice. The western district in the province of Upper Canada has peculiar advantages for horticulture, and I venture to prognosticate it will, at no far distant day, stand high in the cultivation of choice fruits and vegetables. When the settlers properly appreciate the benefits which horticulture, when systematically conducted, is capable of extending to a country; when wealth shall enable the community to call into active exertion the latent powers and susceptibilities

with which nature has gifted this rich gem of the British crown, then we may here expect to see the choicest fruits and vegetables growing in full perfection under the influence of a Canadian sun. This district, from its southerly position, enjoys the mildest and most genial climate in all the Canadas; for harbours and water privileges of the most excellent description; thus rendering it a grand emporium for the interests of agriculture, manufacture, and commerce. On the north, it is washed by the waters of Lake Huron; on the west, it is only separated from an extensive and wealthy tract of the American frontier by the river St. Clair, Lake St. Clair, and the Detroit; on the south, by Lake Erie, and on the east by the flourishing district of London; while its interior is traversed by two of the finest streams in the province.

Goderich. — Ten or twelve years ago, and this tract of land, termed the Huron tract, was literally untrodden by the feet of Europeans, yet such is the rapid march of British industry and perseverance, under the guidance of the Canada Company, that several flourishing towns now exist on it; among which Goderich stands proudly preeminent, indicating a rapid march to wealth and refinement. The town is situated on the shores of Lake Huron, and I was agreeably surprised to find a few spots ornamented with some of Flora's beauties; and, what was well worthy of imitation, several indigenous species were flourishing most vigorously in one or more gardens. I spent some days in this part of the country with Mr. M——, a Scotchman, enthusiastically fond of gardening, and from whose precepts and example I anticipate a good result. It was truly gratifying to witness the kindness and unanimity existing among the inhabitants of this place; which prompt them to display the most friendly attention to strangers, thus at once attesting their own respectability, and that genuine British hospitality extends itself even to the forests of Canada.

Sandwich is a town of considerable size, but, to a gardener, it has not one interesting quality. *Chatham*, in like manner, is also quite barren as regards gardening productions. From this place, along the margin of the Thames, to London, the singularly favourable nature of the country induced settlers, at an early period in the history of the province, to locate in it; yet such has been the lethargy of the settlers, that even now it cannot boast of any one production peculiar to itself, except tobacco and a few fruits. I am happy, however, to say that, in the early part of 1837, an Agricultural and Horticultural Society was organised in the western district, from which much good was justly anticipated; but, like every public improvement in Upper Canada, it has been completely paralysed by the recent disturbances in the colonies. About twenty miles above Chatham, on the river Thames, I found a very flourishing Indian village, which displayed a degree of neatness and comfort rather uncommon among the aborigines. This was, I understood, attributable to the exertions of a clergyman established in the village, and who was indefatigable in promoting the temporal, as well as the spiritual, interests of this Indian community. Nearly opposite to this village, I came to a small natural opening. I had experienced high gratification, during the previous part of my tour, from the botanical treasures which had come under my observation; but in this sweet spot I found the beauties of a vast extent of country concentrated, as it were, into a focus, even some species I never before had found north of Virginia were flourishing here in great perfection. To expatiate on the richness of this spot, according to its merits, would occupy too much space, and, in fact, my descriptive powers are incompetent to the task; it would require the pen of poetic inspiration, properly to describe its unrivalled charms. I rambled admiring, until darkness obscured the diversified hues of the various species, and even then I could not leave the spot. To me it possessed an indescribable fascination; so, in order to renew my researches with Aurora's

earliest dawn, I took shelter for the night in the centre of a thick group of *Asclèpias tuberosa*, which abounded here. Many were my anxious looks for the return of day; and when it arrived I resumed my botanic rambles, and the sun had nearly sunk once more below the horizon, ere I could tear myself away from this enchanting place.

London. — London stands within the forks of the river Thames, where both branches of the river meet. The Thames is a lovely stream, abounding with scenes at once delightful and enchanting. London is centrally situated, and a very flourishing place; the most eligible that I know in the provinces, for the establishment of a nursery, &c., there being nothing of the sort within 150 miles at the lowest calculation. Had I been disposed to adopt a local habitation in the Canadas, this would be the spot which I most certainly should prefer. In all probability the Thames will soon be rendered navigable for steam-boats to the very town of London, which will give a great impulse to its trade, and assuredly its natural capabilities must soon be brought into operation in this improving age.

St. Thomas's is twenty miles from London. Here I found a fair prospect of future excellence; several spots were gaily ornamented with vines and creepers; and a considerable number of showy plants decorated various gardens. My mind was cheered with these trifles; I recollected

“The noblest states from small beginnings rise,
The nestling eagle flutters ere it flies.”

Brentford. — This is a place of considerable size. I found one practical gardener had established himself here, but received no encouragement. Need I add more as to its gardening propensities. Major Winnet has a respectable garden, but his example does not seem to have had much influence.

Ancaster. — Simmons, Esq., Dr. T. Rolph, and several other gentlemen, have given a considerable impulse to gardening in this village. Mr. Simmons has introduced various fruit trees, ornamental trees and shrubs, through Mr. George Charlwood, of Covent Garden, London; and here, as at several other places in America, I had the most convincing proof of that gentleman's extreme care and successful mode of packing. A very large quantity of trees were shown me by Mr. Simmons, jun., which had been ordered from Mr. Charlwood some years ago. They had arrived too late for the inland navigation that fall, and consequently had to remain at New York for the winter. When forwarded in the spring, they arrived at Ancaster in most excellent order, and several were, when I saw them, in a bearing state, healthy, and vigorous. The seat of Mr. Sutor, from Morayshire, Scotland, is near to Ancaster, situated in a lovely dale. Mr. Sutor has a very good garden, in which both trees and vegetables grow most luxuriantly; and the ornamental department has not been neglected. A large collection of flowers were well grown, and judiciously arranged.

Hamilton. — Sir Allan Napier M^cNab has a garden of considerable size, and is now forming various terraces, shrubberies, flower-gardens, and all the other ornamental appendages to a large establishment; Sir Allan's being, I suppose, the most extensive in either of the Canadas. The kitchen-garden is large, and contained some well-grown crops. Near to Sir Allan's, another gentleman, whose name I unfortunately have forgotten, has extensive grounds. Considerable taste is displayed in laying out the place; and method and arrangement are prominent features. The kitchen-garden was in most excellent order, the weeds were decidedly below your economic point; the crops excellent, and the whole concern did great credit to Mr. Gordon, the gardener. I may here remark that I never had a more convincing proof of the benefits derived from selecting trees from a nursery in a more northern latitude than that in which they are to be planted, than came under my observation while examining the trees in this garden. The proprietor had selected the choicest fruits from nurseries in the United States, and at Montreal; and, although the trees from the latter place were not so vigorous when they arrived at Hamilton, no sooner

did they experience the effects of a genial sun and milder climate, than they left those from the States far behind. Peter Hamilton, Esq., has a very good garden here, but this season he has no gardener. On the whole, I do not think there is such a spirit for gardening in Hamilton now, as there was five years ago; as then there were three professional gardeners in places. It is astonishing that a spot so divinely beautiful has not attracted people of fortune to settle there; as there is the most romantic scenery in the background, and Lake Ontario in front, with views the most superlatively sublime.

Dundas. — Dundas is near to Hamilton, and bids fair to compete with it. There are several very spirited individuals at Dundas, and they have displayed a taste in gardening matters far beyond mediocrity. I will now introduce a few remarks respecting the gardening around the Falls of Niagara, with the view of bringing the country regularly before me. Some time ago, a city was contemplated here on an extensive scale, which induced several gentlemen of fortune to locate themselves in this delightful and far-famed region. Lieutenant-General Murray, Dr. Mewburn, Captain Green, Dr. Clark, Mr. Robinson, &c., have all done something in the way of introducing fruit trees, and ornamental trees and shrubs, and although there is nothing very particular at either place, yet it is very gratifying to see gentlemen using their best efforts by precept and example. Queenston and Niagara I pass over, and proceed to the capital of Upper Canada, the city of Toronto.

Toronto. — Of the spirit that exists in this city and its vicinity for horticulture, I feel myself tolerably competent to speak, having some years ago established myself there; and, in justice to the ladies and gentlemen, I must confess, I experienced a support far beyond my most sanguine expectations; but, my *penchant* for exploring the forest, and viewing Nature in her luxuriant wildness, preponderated, and I relinquished the fair prospects of a good business, to gratify my wandering mania. At that time, the province was under the government of the amiable and philanthropic Sir John Colborne. From His Excellency I met with every encouragement. He generously remitted the duties on my introductions; and every novelty was purchased freely. Finding such a predilection for gardening pursuits, I suggested the propriety of establishing a Horticultural Society. The Society was organised with His Excellency as patron; and never did I experience greater satisfaction than attended my duties as corresponding secretary. Subscriptions were freely made, and promptly paid. A public garden was proposed by His Excellency, and several of the leading members of the legislature; every circumstance promised success. I left the Society in a most flourishing state, but on my return, the past summer, I found it had shared the fate of many similar institutions, and that it had passed into the vale of oblivion. Among various gardens in the neighbourhood of Toronto, I may enumerate the following as the most deserving of notice.

The Hon. W. Allen has a very extensive garden and pleasure-grounds. The pleasure-grounds are laid out in good taste, and kept in most excellent order. Mrs. Allen is a great admirer of plants, and displays a most judicious taste in her selections of them.

The Hon. George Markland has a very neat spot, which contains a small green-house, in which I saw some very choice plants, and several fine specimens.

The Hon. George Crookshanks has also a green-house connected with his establishment, and spares no expense in procuring every desirable article.

The Hon. Joseph Wells. — Colonel Wells has an extensive garden, decidedly the best collection of fruits I met with. Here I found everything in first-rate order; “a place for everything, and everything in its place.” System and regularity was conspicuous in the whole establishment, even to the arrangement of the implements in the tool-house. Col. Wells is much attached to horticulture, and was a warm patron of the Toronto Horticultural Society.

The Hon. John Henry Dunn has a well-kept garden, containing some fine specimens of hardy shrubs, a good collection of herbaceous plants, and choice annuals.

The Grounds of the late Hon. Chief-Justice Powell include a very large kitchen-garden, judiciously cropped. Here I found a very extensive assortment of grape vines, with a most excellent crop.

The Hon. Chief-Justice Robinson has a sweet place, including a beautiful lawn, and shrubberies of considerable extent.

W. B. Jarvis, Esq. The seat of this gentleman contains some very picturesque scenery; its capabilities have been managed with a masterly hand, and, when finished, the effect, as a whole, will be very imposing. Mrs. Jarvis is a most enthusiastic votary at the shrine of Flora, and her arrangements are guided by just principles; expense is no barrier. Alive to every improvement, Mrs. Jarvis may justly be considered one of the most munificent patronesses of gardening in the province.

These by no means comprise all the gardens in this city and its vicinity, but they may be considered as the principal of those deserving of any particular notice.

In the Nursery Line, Mr. Mansfield has a rising establishment; and, from his strenuous exertions and persevering zeal, it will soon stand second to none. Messrs. Westland and Leslie are in the seed line. Mr. Fleming has recently established himself at Toronto, where he has a flourishing little place, including a green-house and seed-shop; and Mr. Logan has very recently built a green-house. Mr. Adams has an establishment at some distance from Toronto, which is the oldest in this section of the country; but I am sorry to say, from some cause or other, it is not so well supported as its long standing might lead us to infer.

From Toronto I bent my steps to Kingston. In passing through *Whitby*, thirty miles below Toronto, I was very much gratified to witness a very prevalent taste for flowers, conspicuous at almost every house, either more or less. The buildings were of the best description, with fine improved farms, and everything indicating not only comfort, but refinement. Near to *Coburg*, I accidentally, without any previous information, observed a green-house attached to a farm-house. This aroused my curiosity, and I walked boldly forward to ascertain the proprietor, whom I found to be a Mr. Jeckell from England, and a practical gardener. Mr. Jeckell has a good garden, and a tolerable collection of exotics, the demand for which is not very great, but still there is an occasional call for such articles. Coburg is a very prosperous town, and contains several good gardens, some of which I found in excellent keeping.

From Coburg I passed through Colborne, Bellville, Napanee, and Bath, on my way to Kingston, in neither of which places did I find a garden worthy of notice.

On reaching *Kingston*, I hoped to find something to make amends for late deficiencies; but, judge of my astonishment when I ascertained that there was not a single garden in the whole town; at all events, not one that I considered worthy of the name, and I can safely assert I had by this time become not over fastidious. Mr. Belonge has a small spot, which contains two green-houses, and these cover more than half his garden; his collection of pelargoniums is rather extensive, and he has also a considerable number of the *Cacti*. The plants were in good condition. I re-potted and accurately named the whole collection. Mr. Belonge informed me his sales were very limited, and that he keeps up the collection principally for his own amusement and recreation. There are several vegetable gardens, but nothing approaching even the semblance of a nursery.

Brockville, about fifty miles below Kingston. — Gardening, I found, had received some little attention here; and there were three or four men employed occasionally for a few months during spring and in the early part of the summer, but then their services were dispensed with.

At *Osnabrook*, about fifty miles farther, I found a very excellent garden, of considerable extent, with a durable stone wall around the whole. This garden belonged to Ira Hawley, Esq. The assortment of fruits was excellent, with a very good collection of roses and herbaceous plants, and the whole in

very good order. This was the last place worthy of notice, until my arrival at Montreal. Immediately on my arrival at that city I repaired to

The Blinkbonny Garden, the establishment of Mr. Robert Cleghorn, whom I had long known by reputation. Blinkbonny Garden is, without doubt, the oldest nursery establishment in the Canadas. Mr. Cleghorn came to Montreal about forty years ago, and thirty-five years have elapsed since he commenced the Blinkbonny Garden. A combination of circumstances has induced the owner to convert the grounds into a garden of pleasure or promenade. It is peculiarly rich in indigenous specimens. Mr. Cleghorn's botanical knowledge is extensive and various. I seldom, if ever, during my various peregrinations (and they have not been on a very limited scale), met with any one gifted with the powers of memory to such an extent. Plants that he has not seen since he left England; circumstances of the most trifling import connected with his early studies, and the whole routine of nursery operations when he was in England, are quite fresh in his memory. The inhabitants of Montreal have it now in their power, in the Blinkbonny Garden, to combine science with pleasure. Its numerous shady walks and rural retreats render it a desirable field of recreation for the citizens in general; while its rich and botanical stores eminently adapt it to the pursuits of the scientific. Among many other natives of great beauty I was particularly struck with the splendour of the *Silène régia*. It was in a large mass, above 6 ft. high, and its vivid scarlet blossoms displayed the brilliancy of their colours in great perfection. Mr. Cleghorn some years ago relinquished the cultivation of exotics entirely.

Mr. George Shepherd, Nurseryman, Seedsman, and Florist.— This gentleman commenced business in Montreal in 1834, and his exertions have had a most influential effect on the minds of the gardening community and amateurs in general. Mr. Shepherd's experience in the botanic gardens at Edinburgh, and thirteen years as foreman and sole manager of the extensive nurseries of Mr. Lawson in the same city, speaks for itself as to his practical knowledge and experience. Independently of his superiority in that respect, his zeal and perseverance, combined with the most perfect amenity, have obtained for him a patronage he well deserves. The collection of plants is peculiarly adapted to the taste of the inhabitants of Montreal. Neither labour nor expense is spared, in order to obtain every desirable variety of fruits, plants, and seeds. The plants display a degree of health and vigour quite unrivalled. Mr. Shepherd has just added a large-sized show-house to his exotic department; thus affording to the inhabitants of Montreal a novel specimen of gardening architecture. Mr. Shepherd's knowledge of the local plants of Canada and their localities, for the short period of his sojourn here, is most astonishing. Situated in a rich botanical section of the country, and possessing the most indefatigable perseverance in collecting, Mr. Shepherd would be, in my opinion, a most desirable correspondent for European nurserymen and amateurs to apply to when collections of Canadian plants or seeds are required.* Three points struck me forcibly in Mr. Shepherd's system; accuracy, superior articles, and punctuality. To this I may add the attention shown to every visiter, and the free disposition to communicate information on every subject connected with horticulture. Mr. Shepherd has a seed establishment distinct from the grounds. It is the only shop solely appropriated to the vending of seeds in Montreal.

Gilbault's Botanic Garden.— It is no novelty for me to find, on the transatlantic shores, even from those I should have imagined incapable of deception,

* Since writing the above, I have seen some packages of native plants put up by Mr. Shepherd for Europe. I have had considerable experience in that line myself; yet I confess that, in Mr. Shepherd's superior mode of packing, I learned a lesson well worthy of imitation, and one which I shall not soon forget.

high-sounding scientific names applied to establishments of the most meagre description; but the ultimatum of this misnaming was never brought before me so palpably as on my visit to the above-named establishment. The name itself was prepossessing; and, added to this, I had read an advertisement stating that it contained fifty thousand species. I considered this a misprint, until other circumstances convinced me it was an intended deception to catch the ignorant and unsuspecting. Judge of my astonishment, when I found the whole collection comprised in the small compass of from 700 to 900 pots; and, as near as I could judge, comprising from sixty to seventy species, and the whole in the worst possible condition. Mr. Gilbault is a perfect stranger to me, but it is impossible to censure in sufficiently strong terms the impropriety of deluding the community by such fallacious advertisements. My indignation is so strong on this topic, that I will not trust my pen any more on the subject of Gilbault's Botanic Garden.

Mr. M'Kenzie and Mr. M'Carracher have establishments, but they are chiefly in the culinary line. As respects the private gardens about Montreal, they are numerous; but, as a description of them was published in a former number of the *Gardener's Magazine*, a repetition from me is perfectly unnecessary; more so as these contain nothing particular to merit attention, if I except a green-house in the gardens of John Molson, Esq., and a range of forcing-houses belonging to Asa Goodenough, Esq. There are various amateurs who do much to keep the spirit for horticulture alive; would they were equally numerous and indefatigable in other parts of the country!

Montreal has long been celebrated for large cabbages. I recollect hearing them extolled in Scotland twenty-five years ago. I have certainly seen some fine specimens this autumn, some of them weighing from 40 lb. to 45 lb., and of a very excellent flavour; they are an improved variety of the Drumhead.

A propos to the gardening and botany of Montreal, in the suburbs of Montreal lie the remains of poor Pursh. Pursh, who had done so much for the elucidation of the botany of America, lies here; with no monument, not even a tablet, to point out the last resting place of this most enthusiastic, most indefatigable man. Far be it from me to depreciate the valuable services of my countryman, Mr. David Douglas, but, were these two eminent botanists compared together, who would lose by the comparison, Pursh or Douglas? Yet the former is passed over in silence, while the latter is to be rendered immortal. I sincerely hope this brief allusion to the subject will not be considered obtrusive; and if it would only induce some more influential person to take up the matter, and verify the old adage, "Better late than never," it certainly would, in my opinion, be only awarding a just tribute to departed worth. I have the most positive proofs that if a subscription were commenced by European botanists, it would be warmly responded to by various individuals in Montreal.

In conclusion, I would beg leave to state that I never was an advocate for gardeners coming to this country to act as serving-gardeners. The more I see of the country, the more I am convinced of the correctness of my former conclusions. No man who has filled a respectable gardener's situation in Great Britain can ever feel satisfied with the generality of American situations. I believe it was old Mr. Fraser who, after travelling far and wide, gave it as his firm conviction, there was no place in the world like England for a serving-gardener. I shall only add that, if gardeners will emigrate, let them by all means give the States the preference; for the Canadas ought to be every gardener's last resource.

It was my intention to add a little information on the localities of some Canadian favourite plants; but I fear I have already extended this too far. Probably, next season, I may send you a tolerably complete list, with such information as I may deem of importance.

Montreal, Nov. 16. 1839.

ART. IV. *The Garden Literature of Italy.* By Signore GIUSEPPE MANETTI, of the Administration of the Imperial and Royal Gardens, Monza, near Milan.

THE delay in sending you the list of Italian authors who have written on gardening was occasioned by the difficulty I experienced in obtaining biographical notices of all those authors; and, notwithstanding the careful research which I have made, assisted by a learned friend interested in the subject, I have found much less information than probably you expected.

1. *Peter Crescenzi*, senator of Bologna; born 1230, died 1312. In consequence of his *Opus Ruralium Commodorum*, which he wrote, he is considered as the restorer of the art of agriculture of the thirteenth century. The above-named work is divided into twelve books, eight of which are consecrated to gardening; it has been translated anonymously into Italian by so excellent a hand, as to be considered a text-book of the language.

2. *Marino Angione* published in terza rima, *Il Giardino, in tre Parti diviso*, "The Garden, divided into three Parts." Naples, 1490.

3. *M. Bartholomew Taegio* wrote the dialogue *La Villa*, "The Villa;" a work dedicated to the most excellent and renowned Emperor Ferdinand I. Printed by Francis Moscheni, Milan, 1559, in 4to. *Taegio* does not, however, treat of the art of gardening, but of the pleasures of the villa; and names a vast number of gardens situated in Milan and its vicinity, sometimes mentioning the trees and flowers found in them.

4. *Mark Bussato* published, in 1592, *Il Giardino di Agricoltura*, "The Garden of Agriculture;" in which he treats of all that is necessary for a gardener to know. Venice, by Fiorino, 1592.

5. *Joseph Falcone* wrote *La nuova, vaga, e dilettevole Villa*, "The new, beautiful, and delightful Villa." Venice, 1601, 8vo.

6. *M. John Baptist Barpo* of Belluno published *Le Delizie ed i Frutti dell' Agricoltura e della Villa*, "The Delights and the Fruits of Agriculture and the Villa." In three books, explained in particular descriptions. Venice, 1634, 8vo. The last twelve descriptions consist of flower and kitchen gardens.

7. *Father John Baptist Ferrari*. Born at Siena; entered the Society of Jesuits in 1607; was made professor of Hebrew in the college at Rome. *Ferrari* wrote the *Flora, seu de Florum Cultura*. Rome, 1633, 4to. This treatise is divided into four books, and translated from Latin into Italian by Lewis Aurelius Perugino. Rome, Falcioli, 1638, with plates by Guido Reni, Peter Berrettini of Cortona, and Andrew Sacchi. A rather scarce book. *Ferrari* also wrote the *Hesperides, sive Malorum aureorum Cultura*, in four books. Rome, 1646; in folio, with 101 copperplates, engraved by Bloemaerk.

8. *Friar Augustine Mandirola* wrote *Manuale dei Giardinieri*, "Manual for Gardeners," in four books; in which is taught, 1. the method of cultivating rare bulbs; 2. the cultivation of flowers with roots (herbaceous plants?); 3. the method of propagating the orange and citron tribe. Vicenza, by Rosso, 1652. This work is extracted from the *Florum Cultura* of *Father Ferrari*.

9. *Bartholomew Clarici* wrote *Istoria e Coltura delle Piante*, "History and Cultivation of Plants." Venice, 1726. "We have in Italy some authors who have written well on the cultivation of flowers; but none better or more extensively, and with more perspicuity, than *Clarici*. His treatise on the orange and citron tribe, which forms the fourth part, is a work unique of its sort." Thus speaks *Philip Re* of *Clarici*, as related by *Bartholomew Gamba*, in his work, *Serie dei Testi di Lingua Italiana*, "Series of the Standard Works of the Italian Language, &c." Venice, 1828.

10. *Philip Arena* published *Della Natura e Coltura de' Fiori*, "On the Nature and Culture of Flowers." Palermo, 1768, in three volumes, with many plates.* *Arena* is the best Italian florist whom the eighteenth century has

* It is a singular circumstance, which cannot be accounted for, that the work of *Arena* has three different titlepages. In one, with the date Palermo,

produced. His work is divided into two parts; in the first of which he speaks of the nature of flowers physically, and in the second of their cultivation. This second part is in a great measure taken from the *Flora* of G. B. Ferrari, but without adopting the puerilities of the latter. Perhaps Arena was the first in Italy who defended the theory of the sexes in plants." (See Gamba, in his work already quoted.)

11. *Casimir Affaitati. L'Ortolano in Villa, e l'accurato Giardiniere in Città, "The Kitchen-Gardener in the Villa, and the perfect Gardener in the City."* Vercelli, 1775.

12. *Abbé Gaetano Sestor. Sull'antica Origine dell'Agricoltura, dei Giardini, &c. "On the remote Origin of Agriculture, of Gardens, &c."* A historical dissertation. Turin, 1776.

13. *Francis Brochieri. Nuovo Metodo adattato al Clima del Piemonte per coltivare gli Ananussi senza Fuoco, "New Method of cultivating the Pine-apple without Fire Heat, adapted to the Climate of Piedmont."* Turin, 1777.

14. *Joseph Piccioli. La Coltura dei Fiori e degli Ananassi senza Stufa, "The Culture of Flowers and Pine-apples without Stoves."* Florence, 1797, Anthony Joseph Pagani.

15. *Peter John Piacenza. Esame sui Giardini Antichi e Moderni, "Enquiry into Ancient and Modern Gardens."* Milan, Bolzani, 1805.

Piacenza demonstrates that the invention of modern gardening is not due to the English. He derives it from Asia, and shows that it was known and practised by the Romans. He concludes that the Italians were the instructors of the English in this branch of gardening; since, for several centuries back, gardens of this sort have been formed in Italy.

16. *Dell'Arte de' Giardini Inglesi, "Of the Art of English Gardens:"* anonymous, but which is known to be by *Count Hercules Silva*, a Milanese. There are two editions: one of the year 1809, in one volume 4to; the other in 1813 (by Vallandi), in two vols. 8vo, with 46 plates. This work is taken in a great measure from the *Théorie des Jardins, &c.*, "Theory of the Art of Gardens, &c.," by M. C. L. Hirschfeld, in five vols. 4to.

17. *Chev. Hippolitus Pindemonte, a Veronese. Sui Giardini Inglesi e sul Merito in ciò dell'Italia. "On English Gardens, and of the Merit due to Italy in this respect."* This is a dissertation which is to be found in the *Transactions of the Academy of Padua*. It was also printed separately in that city, I think in 1818; and Silvestri of Milan inserted it in the *Prose e Poesie campestri, "Rural Prose and Poetry,"* of Pindemonte, published by him in 1827. Pindemonte also translated the *Georgics* of Virgil, with the addition of some unedited fragments, and many learned notes on rural affairs.

18. *Lewis Mabil.* Born in Paris, August 1752; died in Padua in 1836. His father having settled in Italy in 1757, he received his education at Padua, where his master was the celebrated Stellini. He devoted himself to the study of agriculture; considerably improved his family estate; and used every endeavour for the establishment of agrarian societies, with the intention of polishing country-people, and altering their inveterate and prejudicial customs in rural economy. In 1761 he was received into the Academy of Padua, with the title of corresponding associate. He filled various honourable situations, in which he gave proofs of his profound knowledge. Latterly he was Professor in the University of Padua. He published the *Teorica dell'*

1768, Arena is called Philip, with the title of Father of the Society of Jesus. In another, also dated Palermo, 1768, Arena is called Ignatius, and is entitled Priest, Doctor of Sacred Theology, and Canon of the renowned college of his native country. In the third, with the date (undoubtedly false) of Cosmopoli, 1771, the work is again attributed to Philip Arena, of the Society of Jesus, Professor of Mathematics. But, on comparison being made, it is always found to be the same work.

Arte dei Giardini, "Theory of the Art of Gardening." Bassano, 1801. Besides this, he wrote *Mabiliana*, or *Varia Selva*, "Various Dissertations on agricultural Subjects, Botany, &c." *Istruzioni ai Coltivatori della Canapa nazionale*, "Instructions to the Cultivators of native Hemp." Padua, 1785. *Mezzi di diffondere tra i Villici le migliori Istruzioni Agronomiche*, "Helps for diffusing among the Country-people the best Instructions on rural Affairs." (In *Griselini's Italian Journal*, fasc. iii. second series.) *Sull' Indole de' Giardini*, "On the Soils of Gardens." Verona, Mainardi, 1817: and various other literary publications.

The above-mentioned minor works of Pindemonte, and the *Theory of the Art of Gardening* by Mabil, were united in a single volume, and printed in Verona in 1817 by Mainardi, to which were added two Academical Papers by the Abbé Melchior Cesarotti.* Upon them, Cesarotti, after having given an account of these works, concludes that gardens in the modern style ought not to be called English, but Italian. To corroborate this conclusion with the authority of the English themselves, Pindemonte quotes at the end of the volume, Eustace's *Classical Tour in Italy*. (*A Classical Tour through Italy* in 1802, by the Rev. John Chetwode Eustace. Third edition, revised and enlarged, &c., 1815, vol. iii.) Mr. Eustace, far from recognising in Milton the origin of English gardens, as most of his countrymen do, attributes it to our Torquato Tasso; for, after saying that "the description of the terrestrial Paradise of Milton is considered as the model of modern parks," adds, "that this is more suitably applied to that of the garden of Armida, not only because our poet furnished Milton with some of the principal features of his description, but because he really laid the first foundation of the art, and comprehended it in a single most ingenious line, with which he concludes the picture of the most beautiful of landscapes.

"L' Arte che tutto fa, nulla si scopra,"

"Art which does all is not discovered."

"If, therefore," says Pindemonte, "the English ultimately confess that the invention of these gardens belongs to Tasso, and if Tasso merely described the park of Turin, it consequently ensues that that park was really a garden in the modern style."

With respect to the park at Turin, there is a memoir by the late Professor of Padua, Vincent Malacarne, read by him in that academy, and which by some is said to have been afterwards printed by Bodoni, but which is not found in the catalogue of Bodoni's books, in which it is proved (exactly what the aforesaid Cesarotti declares in his second article before mentioned) by this authentic document, that Italy, the original mother and mistress of all the fine arts, was also the mother of modern gardening; making it appear that, long before the time of Bridgman, whom the English acknowledge as the founder of the new style of gardens, and of Kent, the supreme legislator of the art, there existed in Piedmont, not far from Turin, a garden exactly of that description, of great extent, most varied, calculated to excite the most interesting sensations, and worthy of being a model for all gardens; contrived by, and executed under the order of, Emanuel, first Duke of Savoy. The garden is no longer in existence; but there is still extant (says Cesarotti) an exact description of it by Aquilino Coppino, a writer of the sixteenth century, and professor at Pavia, in a Latin letter, breathing the sentiments of enthusiasm with which this delightful scene had inspired him; of which letter Malacarne gives a paraphrase.

19. *Philip Re*. Born at Reggio, in Lombardy, March 20. 1763; died May 20. 1817, in Modena. He was Professor in the Lyceum of Reggio in 1791; in 1806, decorated with the iron crown, enrolled in the Society of Forty; in 1812, elected a member of the Italian Institute. By this author we have *Il Giardiniere avviato nella sua Professione*, "The Gardener learned in his

* Art. xvi. in 1795, and art. xviii. in 1798, in vol. ii. of the *Transactions of the Academy*, by Cesarotti; Pisa, 1803.

Profession." Milan, 1812, Silvestri. From this work may be obtained much information concerning the art of gardening, and those authors who treated of it ; and much more from the *Dizionario ragionato di Libri d'Agricoltura, Veterinaria, e di altri Rami d'Economia campestre, ad Uso degli Amatori delle Cose agrarie e della Gioventù*, "Descriptive Dictionary of Books on Agriculture, the veterinary Art, and other Branches of rural Economy, for the Use of Amateurs of rural Affairs and of Youth." Venice, 1808, 4 vols. in 16mo. The same author published, besides these two works, the following : *Proposizioni teoriche pratiche di Fisica vegetabile*, "Theoretical and practical Propositions of Vegetable Physiology." Reggio, 1795, 8vo. *Elementi di Agricoltura*, "Elements of Agriculture." Parma, 1798, 2 vols. *Arte di supplire alla Mancanza di Foraggi*, "Art of supplying the Deficiency of Fodder." Pavia, 1802. *Prolesione alle Lezioni di Agraria*, "Prousions at the Lectures of Agriculture." Bologna, 1804. *Memoria sull' Agricoltura delle Montagne Reggiane del Dipartimento di Crostolo*, "Memoir on the Agriculture of the Mountains of Reggio, in the Department of Crostolo." Milan, 1805. *Saggio di Nosologia vegetabile*, "Essay on Vegetable Nosology ;" inserted in the 12th vol. of the *Transactions of the Italian Society*, Modena, 1805. *Elementi di Giardinaggio*, "Elements of Gardening." *Lettera al Signor Gagliardo sulle Opere agrarie del Crescensi*, "Letter to M Gagliardo on the Agricultural Operations of the Crescensi District ;" inserted in the 10th vol. of Gagliardo's *Biblioteca di Campagna*, "Country Library." *Lettera sul Male che guasta il Frumento, detto Golpe in Toscana e Marzetto in Lombardia*, "Letter on the Disease which destroys Wheat, called Golpe (rust) in Tuscany and Marzetto in Lombardy ;" in the 1st vol. of the *Giornale di Agricoltura*, "Journal of Agriculture." *Lettere Tre sopra alcuni Oggetti relativi all' Agricoltura Italiana*, "Three Letters on Subjects relating to Italian Agriculture." *Dell' Utilità della Teorica agraria*, "On the Utility of Agricultural Theory." *Elementi di Economia campestre ad Uso de' Licei d'Italia*, 1808, "Elements of rural Economy for the Use of the Colleges of Italy, 1808." *Lettera sull'Erba medica*, "Letter on the medicinal Grass." *Annali dell' Agricoltura del Regno d'Italia*, "Annals of the Agriculture of the Kingdom of Italy." 1809 to 1814, vol. 22. " *Saggio della Poesia didascalica-georgica degli Italiani*, "Essay on the didactic-georgic Poetry of the Italians." *Elogio di Pietro Crescenzi*, "Eulogium on Peter Crescenzi." Bologna, 1812. *Istruzione sul Modo di coltivare il Cotono* "Instructions in the Method of cultivating Cotton." *De' Letami*, "On Manures." *Delle Terre coltivabili e del Modo di conoscerle*, "On Soils fit for Cultivation, and Manner of growing them." *Saggio sul Pomo di Terro*, "Essay on the Potato." *Sulle Malattie delle Pianta*, "On the Diseases of Plants." *Saggio storico sullo Stato e sulle Vicende dell' Agricoltura antica dei Paesi posti fra l' Adriatico, l'Alpe, e l' Appennino*, "Historical Essay on the State of ancient Agriculture, and Matters relating thereto, in the Countries situated between the Adriatic, the Alps, and the Apennines."

These are the notices which I have been able to procure, and I flatter myself that they are exact and complete. I have not spared pains in obtaining them from authentic sources ; and, not trusting to my own exertions, I enlisted, as I said before, some learned men into my service, who were of great assistance to me. I have not restricted myself to those authors who have written solely on ornamental gardens, and their works ; but have thought it advisable to include those authors, and their works, who treat of gardening in general, as you will perceive by this list. — *Monza, Aug. 10. 1839.*

ART. IV. *List of Part of the Trees and Shrubs furnished for the Arboretum of Joseph Strutt, Esq., at Derby, by Messrs. Whitley & Osborn, with their Ready-Money Prices.* With Introductory Remarks by the CONDUCTOR.

THE most common ostensible objection to planting collections of trees and shrubs is, the alleged high price of all kinds for

which there is not a constant demand ; though the real objection is sometimes the ignorance of the gardener of the names of rare trees and shrubs, and of their culture ; or his want of enthusiasm in his profession. The present article will show that the objection of high price is an erroneous one ; for in the following list we have nearly eight hundred different kinds, which have cost only 79*l.* 18*s.* Each of the plants sent to the Derby Arboretum had the name written in pencil on a wooden tally previously rubbed with white lead, and the tally tied to the plant with copper wire. Besides which, a list, with the scientific name of each plant, the English name, the native country, height, year of introduction, natural order, &c., from which the permanent labels were to be printed, was made out by Messrs. Osborn, correctly spelt and accented, and sent to Derby along with the plants ; and from this list the labels hereafter mentioned were printed on cards by a printer in Derby, and the accentuations put on with the pen. Thus the trouble attending the execution of this order was much greater than in ordinary cases, notwithstanding the low prices charged. It is to be observed that the bargain was made that the bill should be paid as soon as the plants were delivered, free from all discount, and that this was done accordingly.

Though Messrs. Whitley and Osborn's list is given here alphabetically, as it stands in their catalogue, yet the plants are arranged in Mr. Strutt's Arboretum according to the natural system ; and to each a brick tally is attached, similar to the one represented in *fig.* 14.

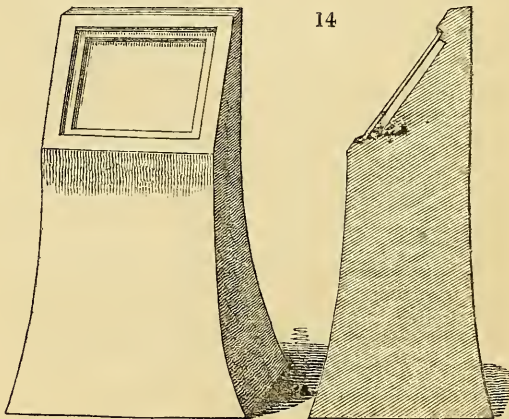

These brick tallies are placed about 5 ft. distant from the plant, on a foundation which is prepared in the following manner :— The ground, having been trenched for the trees or shrubs, must

necessarily be soft; and, therefore, the first step is to render it firm. If very soft, a square of the surface, 15 in. on the side, may be rammed so as to lower it 6 in. below the general surface; but, if not very soft, then 3 in. in depth over a square 15 in. on the side may be removed, and the bottom of this square rammed so as to lower it 3 in. more; in all 6 in. This square excavation must be beat to a perfect level, and next two bricks are to be laid flat on it, side by side. On the centre of this floor of bricks, the brick tally is to be set; and, if thought necessary, it may be fixed with a little Roman cement. This being done, the surface soil is to be filled in, and closely rammed round the bricks, and over them also, so as to cover them to the depth of 3 or 4 inches. The use of the flooring of bricks is to prevent the tally from sinking, or from leaning to one side. The name is printed on a card, and the panel in which it is placed receives previously three coats of paint; and another coat is given to the exterior surface, after the glass is put in and puttied. The cost of the bricks, at Derby, is about 3*l.* per thousand. If the bricks were heated and dipped in oil, or painted with tar or gas liquor, or if they were glazed with the glaze sometimes given to pantiles, their durability would be greatly increased, and the paper card would run less risk of damage from the brick absorbing water from the soil. We have sent one of these tallies to the Hort. Soc., Lawson's Agricultural Museum, Edinburgh, the Adelaide Gallery, the Polytechnic Institution; and, through the kindness of Mr. Strutt, we have still a few more that we shall be happy to send as specimens, either to individuals or public bodies, who may intend to plant Arboretums or name collections. Such are the permanency of the beauty and instruction, and also the economy in keeping in order, of a collection of trees and shrubs, as compared with the beauty and cost of keeping of a collection of herbaceous plants; that, when these properties of an arboretum become known, we hope that one will be considered as essential to a gentleman's country residence, as a flower-garden; and altogether indispensable to a public garden.

Abies D. Don excelsa communis Arb. Brit. 6d., ex. Clanbrasiliana Arb. Brit. 5s., alba Michx. 2s. 6d., nigra Ait. 2s. 6d., Smithiana Wall. 5s., canadensis L. 1s. 6d.

Acer L. tataricum L. 1s. 6d., spicatum L. 1s. 6d., striatum L. 1s. 6d., macrophyllum Pursh 2s. 6d., platanoides L. 1s., p. Lobelii 5s., p. laciniatum Dec. 3s. 6d., saccharinum L. 1s. 6d., Pseudo-Platanus L. 9d., P. albo variegata 1s. 6d., P. purpurea Hort. 2s. 6d., obtusatum Kit. 1s. 6d., circinatum Pursh 5s., eriocarpum Michx. 1s. 6d., rubrum L. 1s., monspessulanum L. 1s., campêtre L. 1s., creticum L. 1s. 6d.

Adenocarpus Dec. intermedius Dec. 2s. 6d.

Æsculus L. Hippocastanum L. 1s., H. variegatum 2s. 6d., (H.) ohioensis Michx. 2s. 6d., (H.) rubicunda Lois. 2s. 6d., (H.) glabra Willd. 2s. 6d., (H.) pallida Willd. 2s. 6d., (H.) Lyonii Hort. 2s. 6d.

Ailántus Desf. glandulosa Desf. 1s. 6d.

Alnus Tourn. glutinosa Gartn. 9d., g. laciniata Willd. 1s. 6d., g. quercifolia Willd. 1s. 6d., g. oxyacanthifolia 1s. 6d., incana Willd. 1s. 6d., cordifolia Lodd. 1s. 6d., viridis Dec. 1s. 6d.

- Amelánchier *Med.* (v.) *Botryàpium Dec.* 1s. 6d., (v.) *sanguínea Dec.* 2s. 6d., (v.) *ovális Dec.* 1s. 6d., (v.) *flórida Lindl.* 2s. 6d., f. *parvifólia* 2s. 6d.
- Amórpha *L.* *fruticósa L.* 1s., f. *Lewisii* 1s., (f.) *glàbra Desf.* 1s.
- Ampelópsis *Michx.* *hederàcea Michx.* 1s., (h.) *hirsùta Donn* 2s. 6d., *bipinnàta Michx.* 2s. 6d.
- Amýgdalus *Tourn.* *nàna L.* 2s. 6d., *commùnìs amàra Dec.* 3s. 6d., c. *dúlcis Dec.* 3s. 6d., c. *macrocárpa Ser.* 3s. 6d., *orientàlis Ait.* 2s. 6d.
- Aràlia *L.* *spinòsa L.* 1s. 6d.
- A'rbutus *Camer.* *U'nedo L.* 1s. 6d., *U. rùber Ait.* 3s. 6d., *U. plènus Ait.* 3s. 6d., *hýbrida Ker* 3s. 6d., *Andràchne L.* 5s., *procèra Douglas* 5s.
- Arctostáphylos *Adans.* *U'va úrsi Spreng.* 2s. 6d.
- Aristolòchia *L.* *sìpho L' Hèrit.* 2s. 6d.
- Aristotèlia *L' Hèrit.* *Mácuì L' Hèrit.* 1s. 6d., *M. foliis variegàtis* 1s. 6d.
- Armeniàca *Tourn.* *dasycárpa Pers.* 2s. 6d.
- Artemísia *Cass.* *Abrótanum L.* 9d., *A. tobołskiànnum Hort.* 9d.
- Atràgene *L.* *alpina L.* 1s. 6d., *sibírica L.* 1s. 6d.
- A'triplex *L.* *portulacóides L.* 1s.
- Aúcuba *Thunb.* *japónica Thunb.* 1s. 6d.
- Azàlea *D. D n* *procúbens L.* 3s. 6d.
- Báecharis *R. Br.* *halimifólia L.* 1s.
- Bérberis *L.* *vulgàris L.* 1s. 6d., v. *álba* 1s. 6d., *canadénsis Mill.* 1s. 6d., *ibérica Stev.* 2s. 6d., *sinénsis Desf.* 2s. 6d., *dúlcis Swt.* 5s., *heterophýlla Juss.* 3s. 6d., *em-petrifólia Lam.* 5s., *asiática Roxb.* 2s. 6d., *aristàta Dec.* 1s. 6d.
- Bétula *Tourn.* *álba L.* 9d., *á. pèndula Sm.* 1s., *á. urticifólia* 2s. 6d., *pùmila L.* 1s. 6d., *nàna L.* 1s. 6d., (*á.*) *populifólia Ait.* 1s., *laciniàta* 2s. 6d., *papyràcea Ait.* 2s. 6d., *lènta L.* 1s. 6d.
- Bòrya *W.* *ligústrina Willd.* 1s. 6d.
- Broussonètia *Vent.* *papyrifera Vent.* 1s. 6d.
- Búxus *Tourn.* *sempervirens arboréscens Mill.* 1s., s. *marginàta Hort.* 1s., s. *myrti-fólia Lam. Ency.* 1s.
- Callúna *Sal.* *vulgàris decúbens Don's Miller* 1s. 6d., v. *flòre plèno Don's Miller* 1s. 6d., v. *fóliis variegàtis Don's Miller* 1s. 6d., v. *coccínea Don's Miller* 1s. 6d.
- Calóphaca *Fisch.* *wolgárica Fisch.* 5s.
- Colycánthus *Lindl.* *flóridus L.* 1s. 6d.
- Caragàna *Lam.* *arboréscens Lam.* 1s. 6d., (a.) *Altagàna Poir.* 2s. 6d., *frutéscens Dec.* 1s. 6d., *pygmæ'a Dec.* 2s. 6d., *spinòsa Dec.* 2s. 6d., *tragacanthóides Poir.* 2s. 6d., *Chamlágu Lam.* 1s. 6d.
- Cárpinus *L.* *Bétulus L.* 9d., *americàna Michx.* 2s. 6d.
- Càrya *Nutt.* *álba Nutt.* 2s. 6d.
- Cassàndra *D. Don* *calyculàta D. Don* 2s. 6d.
- Castànea *Tourn.* *vésca Gærtn.* 1s. 6d., v. *asplenifólia* 2s. 6d., v. *variegàta* 2s. 6d.
- Catálpa *Juss.* *syringæfólia Sims* 1s. 6d.
- Ceanòthus *L.* *americànus L.* 1s.
- Cèdrus *Barrel.* *Libàni Barr.* 5s.
- Celástrus *L.* *scàndens L.* 1s. 6d.
- Céltis *Tourn.* *occidentàlis L.* 1s. 6d., o. *cordàta Willd.* 1s. 6d., *crassifólia Lam.* 1s. 6d.
- Cephalánthus *L.* *occidentàlis L.* 1s. 6d.
- Cérasus *Juss.* *vulgàris flòre plèno Hort.* 1s. 6d., v. *fóliis variegàtis Hort.* 3s. 6d., (v.) *semperflòrens Dec.* 1s. 6d., *serrulàta G. Don* 1s. 6d., *Pseudo-Cérasus* 2s. 6d., *Chamaécérasus Lois.* 2s. 6d., *prostràta Ser.* 2s. 6d., *depréssa Ph.* 1s. 6d., *pygmæ'a Lois.* 1s. 6d., *nìgra Lois.* 2s. 6d., *japónica Lois.* 2s. 6d., j. *múltiplex Ser.* 2s. 6d., *Mahàleb Mill.* 2s. 6d., *Pàdus Dec.* 9d., *P. bracteòsa Ser.* 1s. 6d., *virginiàna Michx.* 1s., *lusi-tànica Lois.* 1s. 6d., *Laurocérasus Lois.* 6d., *angustifólia Hort.* 9d.
- Cércis *L.* *Siliquástrum L.* 1s. 6d.
- Chimonánthus *Lindl.* *fràgrans Lindl.* 2s. 6d., *lùteus Hort.* 2s. 6d.
- Chionánthus *L.* *virgínica L.* 2s. 6d.
- Cístus *L.* *créticus L.* 1s. 6d., *obtusifólius Swt.* 1s. 6d., *corbariénsis Pourr.* 1s. 6d., *oblongifólius Swt.* 1s. 6d.
- Clématis *L.* *Flámmula L.* 1s., *orientàlis L.* 1s. 6d., *Vitálba L.* 9d., *virginiàna L.* 1s. 6d., *triterinàta Dec.* 1s. 6d., *flórida Thunb.* 1s. 6d., f. *flòre plèno* 1s. 6d., *Vitiécèlla cærúlea* 1s. 6d., v. *purpúrea* 1s. 6d., v. *múltiplex* 1s. 6d., *montàna Ham.* 1s. 6d.
- Clèthra *L.* *alnifólia L.* 1s. 6d.

- Colùtea *R. Br. arborescens L. 9d., (a.) cruènta Ait. 1s.*
 Comptònia *Banks asplenifòlia Banks 1s. 6d.*
 Corèma *D. Don álba D. Don 2s. 6d.*
 Coriària *Niss. myrtifòlia L. 1s. 6d.*
 Còrnus *L. alternifòlia L. 9d., sanguínea L. 9d., s. fòliis variegàtis 1s., álba L. 9d., á. sibírica 9d., (á.) strícta Lam. 2s. 6d., (á.) circinàta L'Hérit. 1s. 6d., más L. 1s. 6d.*
 Coronilla *Neck. E'merus L. 1s.*
 Còrylus *L. Avellàna L. heterophýlla 1s. 6d., A. purpùrea 1s. 6d., Colúrna L. 2s. 6d., rostràta Ait. 1s.*
 Cotoneàster *Med. vulgàris Lindl. 1s. 6d., (v.) tomentòsa Lindl. 1s. 6d., (v.) laxiflòra Jacq. 3s. 6d., frígida Wall. 2s. 6d., (f.) affinis Lindl. 2s. 6d., acuminàta Lindl. 2s. 6d., nummulària Lindl. 1s. 6d., rotundifòlia Wall. 1s. 6d., (r.) microphýlla Wall. 1s. 6d.*
 Cratægus *Lindl. coec'nea L. 1s. 6d., c. corállina 2s. 6d., c. indentàta 2s. 6d., c. máxima 2s. 6d., glandulòsa W. 2s. 6d., g. subvillòsa 2s. 6d., punctàta rubra Pursh 2s. 6d., p. strícta Hort. 2s. 6d., p. áurea Pursh 2s. 6d., pyrifòlia Ait. 1s. 6d., macracántha Lodd. 2s. 6d., Crús-gállii spléndens Dec. 2s. 6d., C. pyracanthifòlia Dec. 2s. 6d., C. salicifòlia Dec. 2s. 6d., (C.) ovalifòlia Horn. 2s. 6d., (C.) prunifòlia Bosc 2s. 6d., nigra Waldst. & Kit. 2s. 6d., purpùrea Bosc 2s. 6d., p. altàica 2s. 6d., Douglàsii Lindl. 2s. 6d., flàva Ait. 1s. 6d., (f.) lobàta Bosc 2s. 6d., trilobàta Lodd. 2s. 6d., apiifòlia Michx. 2s. 6d., a. minor 2s. 6d., cordàta Mill. 2s. 6d., spatulàta Elliot 2s. 6d., (A.) marocèana Pers. 3s. 6d., Arònia Bosc 2s. 6d., orientàlis Bosc 2s. 6d., o. sanguínea 2s. 6d., tanacetifòlia Pers. 2s. 6d., t. glàbra Lodd. 2s. 6d., t. Leeàna 2s. 6d., heterophýlla Flugge 2s. 6d., Oxyacántha obtusàta Dec. 1s. 6d., O. laciniàta Arb. Brit. 1s. 6d., O. eriocàrpa Lindl. 2s. 6d., O. Oliveriàna Arb. Brit. 1s. 6d., O. melanocàrpa Arb. Brit. 1s. 6d., O. áurea Hort. 1s. 6d., O. múltiplex Hort. 1s. 6d., O. ròsea Hort. 1s. 6d., O. punicea Lodd. 2s. 6d., O. p. flòre plèno 3s. 6d., O. fòliis argènteis Hort. 1s. 6d., O. strícta Lodd. 2s. 6d., O. reginæ Hort. 1s. 6d., O. præcox Hort. 2s. 6d., O. monógyna Arb. Brit. 1s. 6d., O. apétala Lodd. 1s. 6d., parvifòlia Ait. 3s. 6d., virgínicia Lodd. 3s. 6d., mexicàna Moc. & Sesse 2s. 6d., Pyracántha Pers. 1s. 6d.*
 Cuprèssus *L. sempervirens L. 1s. 6d., s. horizontàlis Mill. Dic. 1s. 6d., thyòides L. 2s. 6d.*
 Cydònia *Tourn. vulgàris pyrifórmis 2s. 6d., sinénsis Thouin 2s. 6d., japónica Pers. 1s. 6d., j. flòre álbo 2s. 6d.*
 Cýtisus *Dec. álbus Link 1s., incarnàtus 2s. 6d., Labúrnum L. 1s., L. quercifòlium Hort. 1s. 6d., L. purpuràscens 1s. 6d., (L.) alpínum Mill. 1s., (L.) a. pèndulus 2s. 6d., nígricans L. 9d., sessilifòlius L. 9d., s. álbus Hort. 2s. 6d., purpùreus Scop. 1s., supínum Jacq. 9d., capitàtus Jacq. 9d., polýtrichus Bieb. 1s., biflòrus L'Hérit. 9d.*
 Dabec'cia *D. Don polifòlia D. Don 1s. 6d., p. flòre álbo Sut. 1s. 6d.*
 Dáphne *L. Mezèrum L. 1s., M. flòre álbo 1s. 6d., M. autumnàle 2s. 6d., pòntica L. 1s. 6d., Cneòrum L. 1s. 6d.*
 Deutzia *Thunb. scàbra Thunb. 1s. 6d.*
 Diervíllia *Tourn. canadénsis Willd. 1s.*
 Diospýros *L. Lòtus L. 2s. 6d., virginiàna L. 2s. 6d.*
 Dírea *L. palústris L. 3s. 6d.*
 Elaeágnus *Tourn. horténsis angustifòlia Bieb. 1s. 6d.*
 E'mpetrum *L. nigrum L. 2s. 6d.*
 E'phedra *L. monostàchya L. 2s. 6d.*
 Erica *D. Don Tétralix L. 1s. 6d., T. álba 1s. 6d., cinèrea L. 1s. 6d., c. atropurpùrea 1s. 6d., c. álba 1s. 6d., ciliàris L. 1s. 6d.*
 Euónymus *Tourn. europæus L. 9d., e. nànum Lodd. 1s. 6d., e. frúctu álbo Lodd. 1s. 6d., verrucòsus Scop. 1s. 6d., latifòlius C. Bauh. 1s. 6d., americànum L. 2s. 6d.*
 Fàgus *L. sylvàtica L. 9d., s. purpùrea Ait. 1s. 6d., s. fòliis variegàtis 1s. 6d., s. heterophýlla 2s. 6d., s. cristàta 3s. 6d., s. pèndula 2s. 6d.*
 Fontanèsia *Lindl. phillyreòides Labill. 1s.*
 Fothergílla *L. alnifòlia L. 1s. 6d.*
 Fráxinus *Tourn. excélsior L. áurea Willd. 2s. 6d., e. críspera Arb. Brit. 2s. 6d., e. verrucòsa Desf. 2s. 6d., e. nàna Lodd. Cat. 2s. 6d., (e.) heterophýlla Vahl. 2s. 6d., (e.) parvifòlia Willd. 1s. 6d., lentisefòlia Desf. 2s. 6d., l. pèndula 3s. 6d., (americàna Willd.) pubescens Walt. 2s. 6d., (a.) sambucifòlia Vahl 2s. 6d., (a.) juglandifòlia Lam. 2s. 6d., (a.) epíptera Vahl 2s. 6d., (a.) ovàta Bosc 2s. 6d., (a.) pannòsa Vent. & Bosc 2s. 6d.*
 Gárrya *Doug. elliptica Doug. 2s. 6d.*

- Gauthèria *L. Shallon Pursh* 2s. 6d.
 Genísta *Lam. radiàta Scop.* 1s. 6d., prostràta *Lam.* 1s. 6d., procúbens *Waldst. & Kit.* 1s.
 Gledítschia *L. triacánthos L.* 1s. 6d., sínensis *Lam.* 2s. 6d., s. purpúrea 3s. 6d.,
 (s.) fèrox *Desf.* 3s. 6d., cáspica *Desf.* 2s. 6d.
 Gordònia *Ellis pubéscens Ph.* 2s. 6d.
 Gymnócladus *Lam. canadénsis Lam.* 2s. 6d.
 Gypsocállis *Sal. vágans Sal.* 1s., cárnea *D. Don* 1s. 6d.
 Halèsia *Ellis tetráptera L.* 2s. 6d., díptera *L.* 2s. 6d.
 Halimodéndron *argéteum* 2s. 6d.
 Hamamèlis *L. virgínica L.* 2s. 6d.
 Hédera *Swartz Hélix L.* 1s., *H. canariénsis Dec.* 1s. 6d., *H. fòliis argéteis* 1s. 6d.
 Helíánthemum *Tourn. cànum Dunal* 1s., cròceum *Pers.* 1s., vulgàre *Gært.* 1s.,
 surrejànum *Mill.* 1s., macránthum *Swt.* 1s., m. múltiplex *Swt.* 1s., rhodánthum *Dunal*
 1s., canéscens *Swt.* 1s., mutàbile *Pers.* 1s., sulphúreum *Willd.* 1s., venústum *Swt.* 1s.,
 Milleri *Swt.* 1s.
 Hibíscus *L. syriacus fòliis variegàtis* 1s. 6d., s. flòre variegàto 9d., s. flòre pur-
 púreo 9d., s. flòre rùbro 9d., s. flòre álbo 9d.
 Hippóphae *L. Rhamnòides mas L.* 1s. 6d., salicifòlia *D. Don* 1s. 6d.
 Hydránga *L. arboréscens L.* 1s., nívea *Michx.* 1s. 6d., quercifòlia *Bartram* 2s. 6d.
 Hypéricum *L. 'elàtum Ait.* 1s., hircínium *L.* 9d., calycínium *L.* 9d., prolíficum *L.* 9d.
 Ilex *L. Aquifòlium L. heterophýllum* 2s. 6d., *A. serratifòlium* 2s. 6d., *A. crispum*
 2s. 6d., *A. fèrox* 2s. 6d., *A. senéscens* 2s. 6d., *A. álbo marginàtum* 2s. 6d., *A. aúreo*
 marginàtum 2s. 6d., *A. aúreo píctum* 2s. 6d., *A. fèrox argéteum* 2s. 6d., *A. f.*
 aúreum 2s. 6d., *A. fructu lùteo* 2s. 6d., baleárica *Desf.* 2s. 6d., opàca *Ait.* 2s. 6d.,
 Cassine *Ait.* 3s. 6d.
 Itea *L. virgínica L.* 2s. 6d.
 Jasmínium *Forskøel frúticans L.* 1s., hùmile *L.* 1s. 6d., officinàle *L.* 1s.
 Jùglans *L. règia L.* 2s.
 Juníperus *L. commúnis L.* 1s., c. suécica *Mart.* 1s. 6d., c. nàna *Willd.* 2s. 6d.,
 virginiàna *L.* 1s. 6d., Sabìna *L.* 1s. 6d., *S. tamariscifòlia Ait.* 2s. 6d., *S. fòliis varie-*
 gàtis *Mart.* 2s. 6d. *S. prostràta* 2s. 6d., phœnícea *L.* 5s., recurva *Ham* 3s. 6d., chin-
 énsis *L.* 2s. 6d.
 Kálmia *L. latifòlia L.* 2s. 6d., gláuca *Ait.* 1s. 6d.
 Kérria *Dec. japónica Dec.* 1s. 6d., j. flòre plèno 6d.
 Koelreutèria *Laxm. paniculàta Laxm.* 1s. 6d.
 Làrix *Tourn. europæa Dec.* 9d.
 Làurus *Plin. nóbilis L.* 1s. 6d., n. salicifòlia *Swt.* 1s. 6d., Sássafras *L.* 7s. 6d.,
 Benzòin *L.* 2s. 6d.
 Lèdum *L. palústre L.* 1s. 6d.
 Leucóthoe *D. Don spinulòsa G. Don* 2s. 6d.
 Ligústrum *Tourn. vulgàre Trag.* 6d., v. xanthocárpum 6d.
 Líquidámbar *L. Styracífua L.* 2s. 6d., imbérbe *Willd.* 1s. 6d.
 Liriodéndron *L. Tulip'fera L.* 2s. 6d.
 Lonícera *Desf. Periclymenum L. serótinum Ait.* 1s., *P. bélgicum* 1s., *P. quer-*
 cifòlium *Ait.* 9d., gràta *Ait.* 1s., tatárica *L. rubriflòra Dec.* 9d., pyrenàica *L.* 1s. 6d.,
 alpígena *L.* 1s. 6d., cærúlea *L.* 1s. 6d., ibérica *Bieb.* 1s.
 Lýcium *L. bárbarum L.* 9d.
 Maclùra *Nutt. aurantiaca Nutt.* 2s. 6d.
 Magnòlia *L. grandiflòra L.* 2s. 6d., g. obovàta *Ait.* 3s. 6d., g. exoniénsis *Hort.*
 3s. 6d., gláuca *L.* 3s. 6d., g. Thompsoniàna 7s. 6d., acuminàta *L.* 2s. 6d., (ac.)
 cordàta *Mx.* 3s. 6d., conspícua *Salisb.* 5s., purpúrea *Bot. Mag.* 1s. 6d., (p.) grácilis
 2s. 6d.
 Mahònia *Nutt. Aquifòlium Nutt.* 2s. 6d., rèpens *G. Don* 3s. 6d.
 Malachodéndron *Cav. ovàtum Cav.* 2s. 6d.
 Menispèrmm *L. canadense L.* 1s. 6d.
 Menzièsia *Smith globulàris Salisb.* 2s. 6d.
 Méspilus *Lindl. germànica L.* 2s. 6d., Smithii *Dec.* 2s. 6d.
 Mòrus *Tourn. nìgra Poir.* 5s., álba *L.* 1s.
 Myrica *L. Gále L.* 1s. 6d.
 Myricària *Desv. germànica Desv.* 1s.
 Negúndo *Mench fraxinifòlium Nutt.* 1s., f. crispum *G. Don* 1s. 6d.

- Onònis L. fruticòsa L. 1s. 6d.*
O'rnus Pers. europæa Pers. 2s. 6d., (e.) rotundifòlia Pers. 2s. 6d.
O'strya Willd. vulgàris Willd. 1s., (v.) virgínica Willd. 1s.
Oxycóccus Pers. macrocárpus Pursh 1s. 6d.
Pæónia L. Moútan papaverácea And. 5s., Báńksii And. 3s. 6d.
Paliúrus L. aculeátus Lam. 2s. 6d.
Pàvia Boerh. rùbra Lam. 2s. 6d., r. hùmilis 2s. 6d., r. h. péndula 2s. 6d., flàva Dec. 1s. 6d., díscolor Sut. 2s. 6d., hýbrida Dec. 2s. 6d., neglécta G. Don 2s. 6d., macrocárpa Hort. 2s. 6d., macrostàchya Lois. 1s. 6d.
Períploca L. græca L. 1s. 6d.
Pernéttya Gaud. mucronàta Gaud. 2s. 6d.
Pérsica Tourn. vulgàris flòre plèno Hort. 2s. 6d.
Philadélphus L. coronàrius L. 9d., c. flòre plèno Lodd. 9d., c. variegátus Lodd. 1s. 6d., verrucòsus Schrad. 9d., (v.) latifòlius Schrad. 9d., láxus Schrad. 9d., (l.) grandiflòrus Willd. 9d., hirsùtus Nutt. 9d.
Phillyrea Tourn. angustifòlia L. 2s. 6d., latifòlia L. 2s. 6d., (l.) oblìqua Ait. 1s. 6d.
Picea D. Don pectinàta 1s., balsàmea L. 1s.
Pinus L. sylvéstris L. 6d., (s.) pumílio Hænke 2s. 6d., p. Mùghus 2s. 6d., ìnops Ait. 1s. 6d., Larício Poir. 1s. 6d., (L.) austriaca Hoss 1s., (L.) Pallasiàna Lamb. 2s. 6d., Pináster Ait. 1s. 6d., Pínea L. 1s. 6d., Cémbra L. 2s. 6d., Stròbus L. 9d.
Pistàcia L. Terebínthus L. 2s. 6d., Lentíscus L. 3s. 6d.
Plánera Gmel. Richárdi Michx. 1s. 6d.
Plátanus L. orientàlis L. 1s. 6d., occidentàlis L. 1s. 6d.
Pópulus Tourn. álba L. 1s., trémula L. péndula 1s., græca Ait. 1s., nìgra L. 1s., n. salicifòlia 2s. 6d., monolífera Ait. 1s., m. mas 1s., m. Lindleyàna 1s., fastigiàta 1s., heterophýlla L. 5s., balsamífera L. 1s., cándicans Ait. 1s.
Potentilla L. fruticòsa L. 9d.
Prúnus L. decíduus Dec. 1s. 6d., verticillátus L. 1s. 6d.
Prúnus Tourn. spinòsa flòre plèno 1s. 6d., doméstica myrobàlana 2s. 6d., marítima Wangenheim 2s. 6d.
Ptèlea L. trifoliàta L. 2s. 6d.
Pýrus Lindl. com. fòlius varieg. 2s. 6d., (c.) nivàlis L. 1s. 6d., (c.) salicifòlia L. 1s. 6d. (c.) amygdalifórmis Vil. 2s. 6d., sínensis Lindl. 2s. 6d., bollwylleriàna Dec. 1s. 6d., variolòsa Wall. 2s. 6d., (m.) prunifòlia W. 1s. 6d., (m.) baccàta L. 1s. 6d., rivularis Doug. 1s. 6d., coronària L. 1s. 6d., spectàbilis Ait. 1s. 6d., A'ria Ehrh. 1s. 6d., A. latifòlia H. S. 1s. 6d., (A.) intermèdia Ehrh. 1s. 6d., (A.) vestità Wall. 2s. 6d., torminàlis Ehrh. 1s. 6d., pinnatífida Ehrh. 1s. 6d., aucupària Gærtn. 1s., americàna Dec. 2s. 6d., Sórbus Gærtn. 1s., lanuginòsa Dec. 1s. 6d., spùria Dec. 1s. 6d., spùr. péndula 1s. 6d., arbutifòlia L. 1s. 6d., a. serótina Lindl. 2s. 6d., (a.) floribúnda Lindl. 2s. 6d., (a.) depréssa Lindl. 2s. 6d., pùbens Lindl. 2s. 6d., grandifòlia Lindl. 2s. 6d., Chamæmèspilus Lindl. 2s. 6d.
Quércus L. pedunculàta Willd. fastigiàta 3s. 6d., p. heterophýlla 5s., p. fòlius variegátis 3s. 6d., p. purpùrea 3s. 6d., sessiliflòra Sal. 2s. 6d., pyrenàica Willd. 2s. 6d., E'sculus L. 2s. 6d., Cérris L. 1s. 6d., C. variegàta 5s., C. austriaca 3s. 6d., C. fulhaménsis 3s. 6d., C. Lucombeàna crispa 3s. 6d., Æ'gilops L. 2s. 6d., Æ. péndula 3s. 6d., álba 1s. 6d., macrocárpa 3s. 6d., Prínus L. 3s. 6d., rùbra L. 5s., coccínea Willd. 1s. 6d., palústris Willd. 2s. 6d., Phéllus L. 3s. 6d., I'lex L. 1s. 6d., gramúntia L. 3s. 6d., coccífera L. 3s. 6d., Süber L. 1s. 6d., Túrneri Willd. 3s. 6d.
Rhámnus Lam. Alatérus L. 1s., A. fòlius aúreis 1s. 6d., hýbridus L'Hérit. 1s. 6d., cathárticus L. 1s., saxátilis L. 1s., Erythròxylon Pall. 1s. 6d., alpinus L. 9d., Frángula L. 1s. 6d., latifòlius L'Hérit. 1s. 6d.
Rhododèndron L. pónticum L. 1s. 6d., p. Smíthii 5s., p. azalèoides 2s. 6d., máximum L. 2s. 6d., (m.) purpùreum G. Don 3s. 6d., catawbiénse Michx. 2s. 6d., punctàtum Andr. 3s. 6d., ferrugíneum L. 2s. 6d., (? f.) hirsùtum 1s. 6d., dàuricum L. 1s. 6d., flávum G. Don 1s. 6d., nudiflòrum coccíneum 2s. 6d., viscòsum Torr. 2s. 6d., Rhodòra G. Don 2s. 6d.
Rhús L. Cótinus L. 1s. 6d., typhìna L. 9d., glàbra L. 1s. 6d., g. coccínea 1s. 6d., venenàta Dec. 2s. 6d., radicans L. 2s. 6d., Toxicodèndron L. 2s. 6d., suavèolens Ait. 2s. 6d.
Ribes L. setòsum Lindl. 1s., triflòrum W. 1s., (t.) nìveum Lindl. 1s., (t.) Cynós-bati L. 1s., (t.) divaricàtum Dougl. 9d., speciòsum 1s. 6d., Diacántha L. 9d., lacústre Poir. 1s., rùbrum L. fòlius álbo variegátis 9d., (r.) alpinum L. 1s., (r.) petræum

Wulf. 9d., (r.) multiflorum *Kit. 1s.*, punctatum *R. & P. 1s.*, nigrum *L. f. foliis variegatis 9d.*, (n.) triste *Pall. 9d.*, (n.) grandiflorum *9d.*, (n.) parviflorum *9d.*, cereum *Dougl. 1s. 6d.*, sanguineum *Pursh 9d.*, s. glutinosum *Benth. 1s.*, s. malvaceum *Benth. 1s.*, s. atrorubens *Hort. 9d.*, aureum præcox *Lindl. 9d.*, a. serotinum *Lindl. 9d.* (a.) tenuiflorum *Lindl. 9d.*, (a.) flavum *Coll. 9d.*

Robinia L. Pseùd-Acacia L. 1s., *P. umbraculifera Dec. 3s. 6d.*, *P. tortuosa Dec. 2s. 6d.*, *P. sophoræfolia 1s. 6d.*, *P. macrophylla 1s. 6d.*, *P. microphylla 1s. 6d.*, (*P.*) viscosa *Vent 1s. 6d.*, hispida *L. 1s. 6d.*, h. rosea *1s. 6d.*, h. macrophylla *1s. 6d.*

Rosa Tourn. ferox L. 1s. 6d., bracteata *Wendl. 1s. 6d.*, cinnamomea *Besl. 1s.*, sulphurea *Ait. 1s.*, spinosissima *L. 1s.*, damascena *Mill. 1s.*, centifolia provincialis *Mill. 1s.*, villosa *L. 1s.*, rubiginosa *L. 1s.*, canina *L. 1s.*, indica *L. 1s.*, sempervirens *L. 1s.*

Rubus L. laciniatus W. 1s. 6d., spectabilis *Ph. 1s.*, fruticosus *L. pompomius 1s. 6d.*, f. foliis variegatis *1s. 6d.*, f. leucocarpus *1s. 6d.*, odoratus *L. 1s.*, nutkanus *Moc. 1s.*

Ruscus L. aculeatus L. 6d., *Hypoglössum L. 1s.*, racemosus *L. 1s.*

Salisburya Sm. adiantifolia Sm. 3s. 6d., a. fem. *3s. 6d.*

Salix L. purpurea L. 1s. 6d., triandra *L. 1s. 6d.*, pentandra *L. 1s. 6d.*, Meyeriana *Willd. 1s. 6d.*, babylonica *L. 1s. 6d.*, b. crispa *Hort. 1s. 6d.*, decipiens *Hoff. 1s. 6d.*, fragilis *L. 1s. 6d.*, Russeliæna *Sm. 1s. 6d.*, alba *L. 1s. 6d.*, vitellina *L. 1s. 6d.*, acuminata *Sm. 1s. 6d.*, Pontederæna *Willd. 1s. 6d.*, aurita *L. 1s. 6d.*, caprea *L. 1s. 6d.*

Sambucus Tourn. nigra L. 1s., n. leucocarpa *1s.*, n. laciniata *1s.*, racemosa *L. 2s. 6d.*

Shepherdia Nutt. argentea Nutt. 1s. 6d., canadensis *Nutt. 2s. 6d.*

Smilax L. aspera L. 1s. 6d., Sarsaparilla *L. 2s. 6d.*, rotundifolia *L. 2s. 6d.*

Sophora R. Br. japonica L. 1s., j. pèndula *10s. 6d.*

Spartium Dec. junceum L. 1s., j. flore pleno *2s. 6d.*

Spiræa L. opulifolia L. 9d., chamædrifolia *L. 9d.*, (c.) ulmifolia *Scop. 9d.*, trilobata *L. 9d.*, hypericifolia *Dec. 9d.*, corymbosa *Raf. 9d.*, bella *Sims 1s.*, salicifolia *L. 9d.*, tomentosa *L. 1s.*, lævigata *L. 1s.*, ariæfolia *Smith 1s.*, sorbifolia *L. 1s.*

Staphylæa L. trifolia L. 1s., pinnata *L. 1s.*

Stuartia virginica 3s. 6d.

Symphoricarpos Dill. vulgæris Michx. 9d., v. foliis variegatis *1s. 6d.*, racemosus *Michx. 1s.*

Syringa L. vulgæris L. 9d., v. alba *9d.*, Josikæa *Jacq. 2s. 6d.*, persica *L. 9d.* p. alba *9d.*, p. laciniata *9d.*, rothomagensis *Renault 9d.*

Tamarix Desv. gællica L. 9d.

Taxus L. baccata L. 2s. 6d., b. fastigiata *2s. 6d.*, (b.) canadensis *Willd. 3s. 6d.*

Taxodium Rich. distichum Rich. 2s. 6d., d. sinense pèndulum *5s.*

Thuja L. occidentalis L. 1s. 6d., orientalis *L. 2s. 6d.*, o. tatarica *2s. 6d.*

Tilia L. europæa L. microphylla 1s. 6d., e. platyphylla *1s. 6d.*, e. rubra *1s. 6d.*, e. laciniata *1s. 6d.*, e. aurea *1s. 6d.*, (e.) alba *Waldst. & Kit. 2s. 6d.*, americana *L. 2s. 6d.*, pubescens *1s. 6d.*

Ulex L. europæa L. 9d., e. flore pleno *1s.*, stricta *1s. 6d.*

Vaccinium L. Myrtillus L. 1s., cæspitosum *Michx. 1s. 6d.*, resinosum *Ait. 2s. 6d.*, *Arctostaphylos L. 2s. 6d.*, (?A.) padifolium *Sm. 2s. 6d.*, *Vitis idæa L. 2s. 6d.*, ovatum *Pursh 3s. 6d.*

Viburnum L. Tinus L. 1s., T. lucida *Ait. 1s.*, Lentago *L. 1s. 6d.*, (L.) prunifolium *L. 1s. 6d.*, lævigatum *Willd. 1s.*, dentatum *Lin. 1s.*, O'pulus stérilis *Dec. 9d.* *Vinca L. major L. 6d.*, minor foliis argenteis *9d.*

Virgilia L. lutea Michx. 1s.

Vitis L. vinifera apiifolia Hort. 2s. 6d., Labrusca *L. 3s.*, cordifolia *Michx. 3s.*, riparia *Michx. 3s.*

Wistaria Nutt. frutescens Dec. 1s. 6d., chinensis *Dec. 2s. 6d.*

Xanthorhiza L. apiifolia L'Hérit. 1s. 6d.

Xanthoxylum L. fraxineum Willd. 2s. 6d.

Yucca L. gloriøsa L. 5s., recurvifolia *Salisb. 5s.*, flaccida *Haw. 1s. 6d.*

Zenobia D. Don speciosa D. Don 2s. 6d., s. pulverulenta *Pursh 2s. 6d.*

All the plants sent to the Derby Arboretum were, from preference, chosen of small size, as most likely to be taken up with roots proportionate to their tops, and consequently to live and thrive in their new situation.

We may state here of Messrs. Whitley and Osborn's *Catalogue*, just published, that it contains the names, correctly spelt and accented, and with the same authorities as in our *Arboretum Britannicum*, of above 1400 species and varieties; of every one of which, without a single exception, they have plants in their nursery, or had at the time the *Catalogue* was published. So particular are Messrs. Whitley and Osborn in this respect, that they have not included in their list about fifty kinds, the plants of which they procured from other nurseries. Of these 1400 kinds Messrs. Whitley and Osborn can send out, this season, 1300 sorts for the sum of 160*l.* Next year the collection will be increased by the addition of all the new species and good varieties that can be got; and the whole will be assiduously propagated, so as to produce healthy vigorous young plants for sale.

In directing attention to Messrs. Whitley and Osborn's *Catalogue*, we think we are doing a service both to nurserymen and country gentlemen; for from this *Catalogue* both can select as complete a collection of plants as can be desired, and with names which, we state without hesitation, are more correctly applied than those to be found in any other nursery whatever. In all probability there are various nurseries where some of the plants may be sold as cheap as in the Fulham Nursery; but assuredly we do not know of one, where so complete and so correctly named a collection is to be procured at so low a price. As we have been partly the means of inducing Messrs. Whitley and Osborn to adopt the nomenclature of our *Arb. Brit.*, we feel bound strongly to recommend them, and their *Catalogue of Trees and Shrubs*, to the public.

Bayswater, Jan. 1840.

ART. VI. *A Year's Culture of the Hyacinth, as practised at Haarlem in Holland, beginning with the Season for Planting, in October.*

(Translated from the *Verhandlungen des Vereins*, &c., of Frankfort on the Maine. By J. L.)

OCTOBER. — The Dutch method of planting bulbs is of all methods the best. The whole piece of ground allotted for them is divided into beds. The first bed is dug from 3 to 5 inches deep (according to the strength or kind of bulb to be planted), and this quantity of earth that is dug out is conveyed to the further side of the last bed in the piece of ground. The bed which has had this earth taken from it is equally raked, and divided into rows, when the bulbs are placed gently upon it. The second bed is then dug out in like manner, and the earth which is taken from it is used for covering the bulbs in the first bed; and in this manner they proceed to the last bed, which is covered with the earth of the first bed, which was deposited

there. When there is but one bed to be planted, it is advisable, if not thought too much trouble, to put a layer of sand where the bulbs are to be placed, or only a little on the very spot on which each bulb is to be placed.

With regard to the space between each bulb, eight of those that are capable of producing flowers are planted on the extent of $3\frac{1}{2}$ ft.; but they must always be put nearer or further apart, according to the strength of the bulbs. Very small bulbs, or those not capable of producing flowers, are not planted singly, but are sown in rows, as it is of no consequence whether the sides or points of these bulbs are next the ground.

Those kinds which grow high and strong should, in general, be planted the deepest, that is, 5 or 6 inches deep. Those kinds that grow low should not be planted so deep; but those kinds which are liable to produce an excess of offsets (*Durchwachs*) must be planted the deepest of all, viz. 6 in. Among the latter may be mentioned in particular *l'Amie du Cœur*. It must also be particularly observed, that, when the soil is stiff, the bulbs must not be planted so deep as when the soil is light. It can be best ascertained during the warm days in spring, if the bulbs have not been planted deep enough; because, when that is the case, the leaves begin to flag; while those that are too deep in the soil assume a yellowish appearance. They then become rather smaller than larger, and have a withered appearance. Those of a very small sort are generally not planted so deep as the other kinds; such as *la Duchesse de Parma*, *la Marquise de la Coste*, *le Bonaparte*, *le Roi Sphéros*, *le Kaiser Alexandre*, &c.

The weather should be dry during the time of planting. If there is a continuance of rain after a space of fourteen days, it is very injurious; because, as the germ prevents the bulb from being completely closed, the water finds its way in, and causes the bulb to rot.

Forced hyacinths should be planted in a lighter soil, because it makes them flower sooner; and those bulbs which are difficult to flower, or which are apt to flower late, should have a light dry soil. Care must be taken, as already observed, that bulbs are not planted again on the same bed for the space of five years; and every year a change of soil must be given, either lighter or stiffer; such as, if the previous soil had been light, it should now be very light, or a stiff soil: but it must be remembered that all those with white flowers do not generally do so well in a stiff soil as most of those with blue flowers, and all those kinds which are apt to have the rot must very seldom be planted in a stiff soil. Yet bulbs which are grown in a stiff soil sometimes, to our great astonishment, produce beautiful flowers; but they generally perish before the next time of plant-

ing; and in general, when you have been so unfortunate as to plant in too stiff a soil (which may be known by the luxuriance of the leaves), it is better to take the bulbs up before they have done growing, as they would be sure to become wrinkled, and perhaps mouldy, afterwards.

November and December. — These are the principal operations for hyacinths during the month of October; and during November the same may be continued, if not finished in October. The weeds, also, must be all taken out from those beds where the bulbs are planted; and the beds must then be nicely raked, and made ready for covering, in case of frost in December. This covering is made of reeds, and the covering which was used for the former year is now put under the new one, so that the whole becomes several inches thick. There is a covering also on the sides of the trenches, fastened down by means of pegs. When there is a continuance of rain, the trenches are filled with water, which must immediately be removed.

January and February. — During the months of January and February, the ground in which hyacinths are to be planted in the following October must be deeply dug, and where the beds are planted, the water must be carefully removed from the trenches.

March. — When frost is no longer apprehended, the covering of the beds may be taken off; but great care must be taken not to remove it too soon, that it may not be necessary to put it on again. After all the beds have been carefully cleaned and raked, they are watered with a mixture of cow-dung and water, which forms a slight crust on the surface, and prevents the wind from causing any irregularity on the beds. That piece of ground which, in the previous months, had been deeply dug and intended for hyacinths the next year, should now be manured as above described, with four wheelbarrowfuls of pure cow-dung to the square yard, which is dug in 1 ft. deep.

April. — Time of flowering. At this time the plants should be carefully examined, to see if by any accident one or two of a different kind have been mixed with those that are pure, and to mark them out. After the bulbs have flowered, the flower-stalks should be cut off, to make the leaves grow stronger, and laid in a place where they can do no injury; because, should they be brought again to the hyacinth beds, they would cause all the bulbs to rot. They cannot even be used as manure for trees, &c.; because, if they are not poisonous, they at least always contain a corrosive property, and to such a degree, that in the month of October the labourers, after working five or six hours among them, become red and fiery all over, and are in very great pain during all this month, till this labour terminates. This pain even prevents sleep.

There are some kinds, and particularly those that have small

bulbs and full strong flowers (so much so, that the flower is out of proportion with the bulb), that should have the flower-stalk cut off as soon as the flowers have expanded, in order that the plant may not die of exhaustion. *Henri IV.* belongs to this kind. It is rather expensive, but very beautiful.

A strong wind after flowering is very injurious; because, as the bulbs are then only beginning to increase in size, the wind blowing them backwards and forwards must retard their growth, and be very injurious to them generally. This is generally obviated by thick edges or palings; and, where there are only a few beds, they can be protected with less trouble.

May. — Attention must be paid in this month to keep the bulbs free of weeds, and to see that none of their leaves are hanging down here and there, which is a sign that the bulbs have not been deep enough planted.

June. — Time for removal. Those bulbs which are in too stiff a soil are generally taken out in the beginning of June, while they are still increasing in size. This must not be neglected; because, although they may appear fine large bulbs, they would, if suffered to exhaust themselves, either wither on the drying-boards, or, for the most part, would perish the following year. They are easily known by their very luxuriant and beautiful growth at this time (the beginning of June), in a soil which is not sufficiently sandy, or contains too much rich or stiff soil; and their beautiful growth must not induce you to let them remain longer in it, as mischief would be sure to follow. It is, indeed, very possible, that the bulbs may afterwards shrivel in some degree, and become mouldy by being disturbed while they are increasing in size; but, as this can be remedied by cleaning and trimming them carefully, there is nothing to be dreaded.

Those plants which are only moderately luxuriant may remain in the ground till the end of June; but the usual time is the middle of this month. A yellow or withered appearance at the tips of the leaves is a sure sign that they have done growing; and, when this is the case, it is advisable to take them out. Dry weather, during this operation, is indispensably necessary; therefore, when there is not a continuation of fine weather, every moment of dry weather or sunshine should be taken advantage of; but in very warm situations, where the sun has too great a power on the sand, care must be taken that those bulbs which are taken out and laid on the ground do not perish by the too great heat of the sun. In that case, this operation should be performed in the morning.

The manner of taking out the bulbs in Holland is nearly as follows: — First, all the leaves are pulled up in the same way as you would pull out weeds. The bulb remains in the ground,

and the leaves break off exactly at the point or summit of the bulb, which it is very necessary to preserve. When the leaves are removed, the bulbs are immediately taken out; and this must not be delayed even to the following day, because, when the leaves are taken away, and wet weather follows, the moisture penetrates into the bulb and makes it sickly. If they have been planted in rows, and in good order, they are easily found again. You must kneel down and take out the first row, and so on till you come to the end of the bed, laying them all in the foot-path. When the bed is empty, it must be raked smooth all over, and a strip in the middle, about a foot and a half broad, made flat and firm by means of a board being pressed upon it, or the back of a spade. On this smooth part of the bed the bulbs must be placed in rows, keeping each sort separate; but care must be taken at all times to lay those that are diseased by themselves, so that they may not infect the others; and, lest any of those that are diseased may have been overlooked when they are laid to dry, they should be so placed that one bulb may not touch the others. It often happens, when the leaves are pulled off, as above described, that they do not come entirely from the point of the bulb, in which case they must be cut, as they would rot off afterwards, and run the risk of destroying a whole bed of bulbs in the course of a few days by the rotz. When they are laid on the strip of ground to dry, the root ends of the bulbs must be turned towards the south, as by this means the rays of the sun will have a greater effect upon them.

When the bulbs are placed on the strip of ground along the middle of the bed, the earth from both sides is thrown over them two or three inches thick. The Dutch expression for this is, lying in the *Käuil* (cool). The length of time they lie in the *Käuil* depends upon circumstances. If the bulbs are large and well grown, they should only lie about a fortnight, because if they are kept longer in it, they are in danger of having the rotz; but, if they are of a moderate size, they should remain in it three or four weeks. A good deal also depends upon the weather; because during damp weather, or when it varies from moist to warm weather, they must all be taken out sooner, so as not to run the danger of a very serious loss.

There are two artificial methods of propagating bulbs in Holland: one is by means of crosscuts (*Kreuzschnitte*), the other by hollowing out the bulb (*Höhlung*). Those bulbs that are to be propagated by means of crosscuts must undergo the operation before they are laid in the *Käuil*.

The strongest and most healthy bulbs must be chosen for either of these operations, as that is the only chance of obtaining young healthy bulbs. Therefore, when you select bulbs for

propagating, and are convinced that they are perfectly healthy, without cutting any part off, make four crosscuts in the root end half-way up the bulb, after which the bulbs should be laid in the *Käuil*, and taken out again like the others.

These cuts open pretty wide the same autumn, and send out young bulbs at the cut scales. They must then be planted in this state by themselves; and the next year, after having been dried on the boards, they are separated and trimmed. While they are increasing in size, very little foliage, or none at all, appears on the surface of the bed, as the old bulb has no longer any influence, and the young ones only exert their strength towards their own increase.

The manner of propagating by hollowing out the bulb shall be treated of presently.

July. — According to the above-mentioned treatment, the removal of the bulbs from the *Käuil* takes place either in the beginning or the middle of this month. You must take care that the weather is fine, so as not to run the risk of a serious loss, and also that the rays of the sun do not fall for too great a length of time on the bulbs, because it might easily happen that great injury might be done, particularly between eleven and three o'clock, and it is therefore better that this work should be performed every morning between five and eleven. The removal of the bulbs from the *Käuil* is easily understood. The two or three inches of earth that were thrown over the bulbs are raked off, when the bulbs are easily taken out; they are then laid separately, so that the air and the sun may dry them in the course of two or three hours. They are afterwards put into a parchment-sieve, and carefully shaken, which frees them of all the dry roots and scales. If the sieve is not of parchment, it may be of any soft material, and the sides should be stuffed, to prevent the bulbs from sustaining any injury. They are then brought into the bulb-house and laid on the drying-boards, where they may lie close to each other, but not on each other. Whenever the bulbs are handled, great care must be taken that all those that are diseased or dead, and particularly those that have the rotz, are removed from the others.

The beds which are now empty may be planted with vegetables.

August. — Time of packing. Those bulbs that are intended for sale must be selected and examined as above mentioned, to see that none are sickly among them. If this month be not moist, propagating by means of hollowing out the bulb may be performed; but, if the contrary, it must stand over, and, when this is the case, it is better to wait till the following August. It is very desirable, as has been already mentioned, that healthy and strong bulbs should be chosen for propagating, as it not only

insures healthy young ones, but a greater number of them. The manner of hollowing out the bulb is as follows:—

Place your thumb on the root end of the bulb, and cut round it with a sharp knife, hollowing out the plate or root end as far as the middle of the bulb, and when the knife has passed in a circular direction round the bulb, be particularly careful to take it out again where the incision began, or rather so to perform this circular cut, that the plate extending half-way into the bulb may fall out of itself. As this operation causes a great deal of moisture to flow from the bulb, and also a great degree of danger of its rotting away, it is therefore very advisable that it should not be undertaken during moist weather. The hollowed out part of the bulb ought not to be touched either with the finger or any thing else, and the best way is to strew a dry board with fine dry sand, to lay the bulbs upon it, and to turn the hollowed out part to the sun.

The sun dries them, and also the heart, which extends as far as the point (Nase) of the bulb, and which was not removed when the bulb was hollowed out, but now becomes detached by the heat of the sun, and can be taken away with a chip of wood. When the hollowed part is properly dried, some shelves, or a stand, should be prepared in a very dry place, and strewed with very fine and dry sand 1 in. thick, on which should be laid the hollowed out bulbs till they are planted. If the weather is dry, they ought to have air; but, if it is moist, the air should be excluded.

In some places the hollowed out plates are used, because these also produce young ones; but they are in general not much valued, and are often thrown away, as the young bulbs are never vigorous.

When the hollowed out bulbs are set in the sun, care must be taken that they are not burnt when the sun is too hot, in which case they should be put in a green-house behind the sashes. They must be looked at at least twice a day, because they very soon begin to rot; and, if this is neglected for one or two days, a very serious injury may be sustained.

If any of them should have begun to rot, the part should be cut off if possible, and the bulb replaced in the sun and air; but still an injury is sustained, as the number of young bulbs will be diminished. A great many young ones, as small as grains of corn, are found on the scales before planting, which should be planted rather sooner than any of the others.

When this kind of propagating proves successful, a great many young ones are obtained, but it generally takes four or even five years to bring them to perfection; whereas those that are obtained by the crosscuts only take three years, but not

nearly so many young ones are obtained. Those which are raised from hollowing out, as well as those from the crosscuts, do not produce any leaves on the surface of the bed the first year. Both should be planted separately, in a suitable part of the garden, and in the kind of earth used for hyacinths.

September. — Packing should go on during this month; and it must be particularly remembered that all those beds on which hyacinths or other bulbs are to be planted must now be dug $1\frac{1}{2}$ or 2 feet deep, so that planting may begin in the following month. These beds, which had been already dug deep in the months of January and February, and in which (as has been mentioned) the dung was dug 1 ft. deep, were cropped with vegetables or annuals during summer.

ART. VII. *Notice respecting some new hybrid Primroses raised between the Polyanthus and the Chinese Primrose.* By JAMES SEYMOUR, Kitchen-Gardener to the Countess of Bridgewater, at Ashridge.

I ENCLOSE three blossoms of seedling *Primula*; one a fine lilac, which was raised between a dark polyanthus and a fringed Chinese primrose; and the other two, shades of pale lilac, the result of a cross of the pink variety of Chinese primrose with the white. I have other seedlings, the produce of a cross between the common primrose and *Primula sinensis*; their foliage partakes much of that of the common primrose, but they have not yet flowered.

To have good *Primula* plants to bloom early in the autumn, I sow the seed about the middle of February, in a light sandy soil, in pans well drained, placed in a frame with a gentle heat, and where they can have both air and light. When the plants come up, and are large enough for potting, I prick them out into small pots in a compost of leaf-mould, white sand, bog soil, virgin loam, and a little sheep's dung, mixed all well together. The plants are kept growing, and shifted into larger pots as they require; taking care not to give them too large a pot at once, and to keep them well drained. I give the plants occasionally a little sheep-dung water, which I have found is of great use. They must not want water at any time, and yet too much must not be given to them at once; for, if the soil be suffered to become sodden at any time, the plants are apt to give way at the collar; and if, after being wet, they are suddenly dried, and exposed to a hot sun, it does them much harm, and particularly if they are in bloom, as the flowers are then sure to fall off. When I want a few plants more bushy than usual, and to flower in the winter and spring, I cut the flower stems out in the autumn. The pots ought to be pretty well filled with roots before the winter; as this will prevent the plants from damping off. I likewise make a sowing in June, to have them in bloom late in the spring; always selecting the best-shaped flowers, with good colour, and fringed, for saving seed from. I generally impregnate the pin-eyed ones by taking the pollen of a superior rose-eyed one with a penknife, and putting it upon the stigma of the other; to impregnate the rose-eyed ones, I put my mouth to the flower, and gently draw my breath, and return it into the bloom. If I want a fine specimen plant in bloom, I take a pair of grape scissors and thin the blooms, as well as the flower stalks, altogether.

The changeable-flowered variety, which changes from a pure white to a rosy pink, had 9 flower stems, with 58 flowers in bloom, and 71 buds; making a total of 129 buds. Flowers 2 in. in diameter; leaves 5 in. each way. Plant

2 ft. across, and $8\frac{1}{2}$ in. in height (I do not let the flower stems have more than one to two trusses of blooms on each), in a 24-sized pot. Feb. 28. 1839.

The dark-flowered variety had 7 flower stems, with 43 flowers in bloom, and 64 buds, making a total of 107 buds; average size of the blooms $1\frac{1}{4}$ in. in diameter. Plant $7\frac{1}{2}$ in. in height; 16 leaves upon the plant, $5\frac{3}{4}$ in. each way. Rose eye. Leaves drooping, and very much cut; centre stem 13 flowers in bloom, and 13 buds, total 26 buds. Plant 15 in. across, in a 32-sized pot. Feb. 25. 1839.

Frithsden Gardens, Ashridge, Great Berkhamstead, Jan. 10. 1840.

ART. VIII. *On retaining the Tendril of the Grape Vine.* By R. T.

IN the remarks which have come within my reach, on the culture of grapes, I have never seen any thing respecting the propriety of retaining or taking off the tendril or clasper, which grows on the bunch, and which, if left on, usually perishes. I mean if under glass; as, if it is on the open walls, it will be frequently found to twist round the nails or shoots of the vine, and thus support the bunch; but, owing to the bunches hanging down, it seldom happens that there is anything within the reach of the tendril to which it can cling, and consequently it dies. Whether there are any cultivators who endeavour to preserve it, considering it essential, I do not know; but, as we are taught to believe that the Great Creator has made nothing in vain, I am inclined to think that even this is worthy of notice. I believe it will be found that most people take the tendril off; as some say it draws the nourishment from the bunch; but I am inclined to think otherwise: and I wish to call the attention of your readers to it at this time, as the forcing season is coming on; and, if hitherto they have taken no notice of it, they will (some of them, at least) I hope, turn their attention to it, and report accordingly.

I have taken up the subject in consequence of hearing a person say, when walking through the viney, and seeing the tendrils taken off without any apparent injury, that he had been told that if they were taken off the bunches would go blind. This we are sure would not be the result; but I would ask, of what use is the tendril, when at so early a stage it is so common to see it wither away under glass, and at the same time, if out of doors, and able to lay hold of any thing, it will remain with the bunch through every stage, growing with its growth, and, at last, ripening with it? Not wishing the above remark to be useless, I paid some little attention to it through the summer, by placing some of the bunches so that the tendrils should come in contact with the wires or shoots, and in some cases twisted them once or twice round; and, from what I observed, I am confirmed in the opinion, that they should never be taken off: but, as I do not wish any one to believe it without further proof, I hope some one will be induced, as well as myself, this spring, to give it a fair trial, as it will cause but little trouble and may be useful.

Middlesex, Dec. 27. 1839.

ART. IX. *On the Cultivation of the Alpine Strawberry in Pots.*

By JAMES SEYMOUR, Gardener to the Countess of Bridgewater, at Ashridge.

I sow the seeds in boxes, about the middle of February, in a light sandy soil, and place the box upon a flat hot-water pipe, in a viney, where it is not too hot; taking care to sow the seed very thin, and to cover it very slightly. The seed should be saved the year previous to sowing. I always save my own seed, from some of the largest and earliest fruit, as there is much difference in the shape and size of this kind of strawberry. The soil I use is a

mixture of loam, leaf-mould, cucumber-soil, and white sand, well incorporated together. The plants must be pricked out into boxes, and, when large enough, potted into small pots well drained; and they must be shifted as they may require it, till they are potted into 24- and 16-sized pots. They will require to be smoked frequently to destroy the aphides. They are best grown under glass, either in frames, or in a vinery where they can have plenty of air and light. In July they will perhaps require to be placed in a shady place out in the open air; the pots had better be placed upon boards, slates, or something of that sort, to prevent the roots from getting through; and occasionally watered with dung-water. I always cut off the runners, and likewise the flower stems, till about August; and I find that the fruit is much improved by thinning out a portion of the blooms and stems; and by attending to this point there may be good fruit from September to January. I place in August and September a portion of the plants upon a peach-house shelf, where they have always plenty of air and sun, and are sheltered from heavy showers of rain. I keep the plants upon shelves by the front sashes of a fig-house, for the late crops. In 1837, by this method, I had alpine strawberries particularly fine, and till after Christmas; and at that season of the year they are a great acquisition at a dinner party. I gathered a very nice dish on the 31st ult., and have plants in fruit and blossom at this time, 10th January, 1840.

Alpine Strawberries in the open Ground.—The plants that have been forced, I have planted out in the open quarter in rows 2 ft. 6 in. apart, and plants 2 ft. apart in the rows, in the spring; the ground being well dunged and dug in the autumn and winter previous. At the time of planting I point in a little sand; and I put the balls entire from the pots into a trench prepared for them. The runners must always be taken off; and also the flower stems, till they may be wanted for fruit. I let a few plants go to flower, and ripen fruit, to succeed the other sorts; so that I have had strawberries from the forced plants (Keen's seedling, &c.), till they came from the south borders, quarters, north borders, then alpiners; and, when they were killed by the frost, I then had my plants in pots, ready to succeed them, to this time. I have saved some seed from the alpiners, which have been crossed by the old Carolina. I gathered from 112 ft. of rows of strawberry plants, 56 pints of strawberries, besides what were spoiled with rain, &c. I think it would be useful to put straw, fern, &c., between the rows, to keep the fruit clean; and, if there were a thin board to stand on, the ground would not be trodden so solid. The plant will require plenty of water in hot weather.

Frithsden Gardens, Ashridge, Jan. 10. 1840.

ART. X. *On the Culture of the Chicory as a Winter Salad.*

By JAMES CUTHILL.

THE specimen of chicory root which I exhibited in the Horticultural Society's Rooms in December was 15 in. long, and of proportionate thickness; and it was allowed by Dr. Lindley to be a very superior sort of chicory. The doctor, when speaking of it, observed that in general chicory was not liked, on account of its being so very bitter; the same was stated by Mr. Johnson, at a lecture he gave at Kennington Horns; but not a single gardener knew it in either of the rooms, and some went so far as to say that it was a bad specimen of a white carrot. Now, I grew chicory for four years at Dyrham Park, and it was very much liked by all the family, and no one prided himself more on a good salad than Captain Totter; and, on company days, the empty salad bowl showed how much it was liked by the company. Now, I have another proof that chicory is not disliked on account of its bitterness, and that is, my friend Mr. Cockburn at Kenwood has grown it for some years, and his noble master very much approves of it; and I am sure the persons who partake of this salad at Kenwood must be very numerous. I

hope the above proofs will induce gardeners to give the chicory a fair trial. I have never talked with any traveller who has not always praised the foreign salads, which every body knows are principally composed of chicory; and is it reasonable to suppose that an English gentleman will give the foreigners great credit, and condemn the same article in England? No, no; it is the gardener's fault. My time of sowing chicory is about the first of June, either by broadcast or drills. When the plants are up, thin them to 1 ft. apart, and keep the ground free from weeds; take the roots up in November, and lay them by exactly like beet roots. When the endive is over, plant your chicory in 16-sized pots, five in each pot. Cover the plants over with 24-sized pots. Exclude all air, place them in a forcing-house or frame, and each pot will afford three or four cuttings. Experience will soon teach how many pots will be required. A dark mushroom-house, where a fire is kept, is excellent for growing chicory, without a border made on purpose; a cellar is also a good place for growing the main supply for spring, but it will not do to trust to a cellar for an early crop, it being too cold. I grew chicory in a cellar at Dyrham Park, and the produce was immense in March and April, from two to three hundred roots. I have saved the true sorts of chicory, and shall have a good supply of seed for 1841.

Love Walk, Denmark Hill, Camberwell, Jan. 1840.

ART. XI. *On the Culture of Seymour's Superb White Celery.*

By JAMES SEYMOUR.

THIS celery, raised by my father in 1830, is noticed in the *Gardener's Magazine* for 1839, p. 96., where the dimensions and weight to which it has been grown are mentioned. I sow the seed for the first crop in the first week in February, in boxes filled with light rich loam; the top soil being finely sifted. I place them on a flue in a pine-pit, taking care that the soil does not get dry. When the plants are ripe, I remove the boxes to a vinery. When the plants are in rough leaf, I have them pricked into a frame, placed on a slight hot-bed. As soon as they are 5 or 6 inches high, and sufficiently hardened, I finally plant them out in the trenches, 9 in. apart, in a mixture of fresh loam, rotten dung, and a small quantity of sheep-dung. The second crop I sow the first week in March, and treat them in a similar manner.

I have my trenches made 2 ft. wide, 1 ft. deep, and 8 ft. apart from centre to centre. They are thrown out in the autumn for my first crop; and I then occupy the ridges with hand-glass cauliflowers for my main crop. I have the trenches thrown out about Christmas, and occupy the ridges with early peas, from which I have had the finest crops I ever saw. The trenches I have made as near a water tank as possible, that they may receive an abundant supply during summer, for without this fine celery cannot be grown.

I dug up two heads of Seymour's superb white celery on September 12. 1839, which weighed, when dressed for table, 4½ lb. Two heads, on the 19th of November, 4¾ lb., ready dressed. By superior cultivation it has been grown much finer than I have grown it. Mr. J. Kingston, mentioned in your vol. for 1839, p. 96., has grown it, averaging the weight of each head, and taking two rows of 24 yds. in length each row, from 9 lb. to 10 lb. after the soil and outside leaves have been taken off. Mr. G. Seymour (a cousin of mine) has grown it rather larger, the plants in both cases being received direct from my father.

One great advantage of growing this celery is, that it is never hollow in the leaf-stalk, and is less liable to run than any other I have heard of. Last year, out of two rows, each 30 yds. long, planted from the first sowing, I had but three plants run. The red sort does not stand so well as the white for an early crop, but much better for a late one; it being more hardy and equally fine in flavour.

This sort has been grown by our family for nine or ten years, and by a few friends who have received plants from us in the spring, not having seed for distribution. It is rather shy in producing seed; I believe my father has not been able to save any for several years, which is one reason the sort is so little known, and so sparingly given to the public, and until last year it was not to be had of any seedsman. Messrs. Brown, at Egyptian Hall, Piccadilly, had a small quantity of seed of the red sort; and Mr. J. Lane, nurseryman and seedsman of Great Berkhamstead, Herts, informs me, he has been fortunate enough to save a small quantity of seed of the white sort, by planting a few plants given to him by me on a south border, and he intends sending it out this spring at 2s. 6d. per packet.

I hope my brother gardeners will endeavour to procure this sort as soon as possible, and save seed from it, so that it may soon get into the hands of all seedsmen.

Kitchen-Garden, Ashridge, Dec. 1839.

REVIEWS.

ART. I. *Catalogue of Works on Gardening, Agriculture, Botany, Rural Architecture, &c., lately published, with some Account of those considered the more interesting.*

THE Theory of Horticulture; or, an Attempt to Explain the Principal Operations of Gardening upon Physiological Principles. By John Lindley, Ph.D. F.R.S., &c. 8vo, pp. 387, numerous woodcuts. London, 1840.

The name of the author is a sufficient guarantee for the excellence of this work, which will henceforth be considered essential to the library of every gardener, young and old. It combines the essence of all that has been written by Mr. Knight on vegetable physiology, and of much that has appeared in other works, foreign and domestic, together with the author's experience, observation, and reasoning. This book, Dr. Lindley's *Introduction to Botany*, Kollar's *Insects*, and the Second Part, containing the Natural Arrangement, of our *Hortus Britannicus*, form a garden library that may be said to contain the essence of every other book that a gardener can want.

A Treatise on Insects injurious to Gardeners, Foresters, and Farmers. By Vincent Kollar, Curator of the Royal Cabinet of Natural History at Vienna, and Member of many learned Societies. Translated from the German, and illustrated with engravings, by J. and M. Loudon. With Notes by J. O. Westwood, Esq., F.L.S., &c., Secretary to the Entomological Society. Small 8vo, pp. 377, numerous woodcuts. London, 1840.

We have announced this work as forthcoming in our preceding volume, and also strongly recommended it there, having perused great part of it in manuscript. The treatise is exceedingly valuable in itself from the many original observations which it contains, and which are not to be found in any other work whatever; and this value is greatly increased to the English reader by the notes of Mr. Westwood; and to the practical gardener, forester, and farmer, by the numerous and beautiful wood-engravings. The value of the work to practical men may be judged of by the following summary of its contents:—

Introduction. On the advantages of studying entomology by the gardener, agriculturist, and forester, and on the method of doing so. Sketch of insects, and their classification, transformations, food, distribution and habitat, uses, means of defence against.—Section I. Subsect. 1. Insects which do not live on the body, but are troublesome from their attacks on man, containing 13 articles. 2. Insects which live on domestic animals, containing 9 articles. 3. Insects, not parasitical, but which sometimes

attack domestic animals, containing one article on the Hungarian gnat. 4. Insects which injure bees, containing 6 articles. — Section II. Insects which injure grain in a growing state, and in the granary; and which are injurious to meadows, fodder plants, and culinary vegetables. Subsect. 1. Insects which injure grain, containing 11 articles. 2. Insects injurious to meadows, containing 4 articles. 3. Insects injurious to culinary vegetables, containing 20 articles. — Section III. Insects which injure the vine, green-house, and hot-house plants, orchards, and woods. Subsect. 1. Insects which injure the vine, containing 6 articles. 2. Insects which particularly injure green-house and hot-house plants, containing 11 articles. 3. Insects injurious to fruit trees, containing 37 articles. 4. Insects which are destructive to woods and forests. A. Insects destructive to deciduous trees, containing 4 articles. B. Insects destructive to the pine and fir tribe, containing 20 articles.

If we were asked what book we would recommend to a young gardener to study entomology as a science, we should recommend the elementary works of Mr. Westwood and Mr. Inghen; but, if the question were how to get a practical knowledge of insects, and the mode of defeating their attacks, without much study of technicalities, we should unquestionably recommend Kollar, as by far the best book for the practical gardener, forester, and farmer, hitherto published in the English language. This work, and Dr. Lindley's *Theory of Horticulture*, are two of the best gardening books that have been published for several years.

Annual Flower Seeds sold by E. Sang and Sons, Nursery and Seedsmen. Square 12mo, pp. 14. Kirkcaldy, 1840.

Fruit Trees grown by E. Sang and Sons, Nursery and Seedsmen. Square 12mo, pp. 19. Kirkcaldy, 1839.

Seeds and Implements sold by E. Sang and Sons, Nursery and Seedsmen. pp. 35. Kirkcaldy, 1840.

A List of Geraniums cultivated and sold by E. Sang and Sons. 4to. Kirkcaldy, 1840.

We received the above little books under a cover, open at both ends like those put on newspapers, with the words "Paid — under 2 oz." at the top of the cover, and the words "E. Sang and Sons' Catalogues for 1840," printed at the bottom. The package was pre-paid 4d. We mention this as a hint to other nurserymen.

The Catalogue of Annuals is got up with great taste. There is a table of packets from No. 1. to No. 8., varying in price from 6d. to 16s.; the first containing four "of the prettiest sorts," and the last, No. 8., containing one hundred "of the prettiest sorts," which, at 16s., is less than 2d. a sort. The names of the 100 are given, and afterwards 229 sorts of annuals are shortly described. We have no doubt that half a dozen seeds of the whole of these 229 sorts might be obtained for 2l. and that they would not weigh more than a prepaid fourpenny letter. So great a number of sorts would make a magnificent display in a flower-garden, without the aid of either perennials or bulbs; and the beauty of annuals is, that they will grow and flower in all climates from the frigid to the torrid zone.

The Fruit Tree Catalogue, by means of abbreviations, and a column of remarks, contains a great deal of information, and the selection of fruits is peculiarly adapted for Scotland.

The Catalogue of Seeds and Implements contains a Kitchen-garden Kalendar, arranged on one side of a folding leaf about the size of an octavo page, which is a model of comprehensiveness and condensation. The Catalogue of Implements is the most complete one which we have ever seen. It contains about 150 articles, with their prices varying from 3d., the price of a common dibble, to 22s. that of a brass syringe. Messrs. Sang's example, we trust, will be followed by many other nurserymen, and prove beneficial to all.

Appendix to the First Twenty-three Volumes of Edwards's Botanical Register ; consisting of a complete Alphabetical and Systematical Index of Names, Synonyms, and Matter, adjusted to the present State of Systematical Botany ; together with a Sketch of the Vegetation of the Swan River Colony. With nine coloured Plates, containing eighteen coloured Figures of Plants, and with four Woodcuts. By John Lindley, Ph. D., F.R.S. and L.S., Professor of Botany in University College, London, &c. &c. 8vo, pp. 58. London, 1839.

This work is most interesting on account of its letterpress, and the very beautiful coloured plates by which it is illustrated ; and, as containing an Index to the whole of the *Botanical Register*, it will be found of the greatest value to the possessors of that work, and indeed to botanists generally. We have only therefore to repeat the strong recommendations which we gave of it in our preceding volume.

A Flora of North America ; containing abridged Descriptions of all the known indigenous and naturalised Plants growing north of Mexico ; arranged according to the Natural System. By John Torrey and Asa Gray. Parts I. and II. 8vo, pp. 360. New York, 1838.

This work is to consist of three closely printed 8vo volumes of about 550 pages each. The first volume will comprise the exogenous polypetalous plants, and of it two parts have already appeared. Judging from these parts, and the high reputation of the authors, there is every reason to believe that the work will be worthy of the present state of scientific and practical botany in America. In the two parts before us, we are happy to observe a disposition to simplify and combine, rather than to multiply species and varieties. The reductions which have taken place in the genera *Vitis*, *Ampelopsis*, and especially *Rhus*, are in our opinion extremely judicious. Those in *Vitis*, we think, might even have been carried farther. After this *Flora* is completed, the next grand step of the Americans will be to collect all the plants of their country into one garden, and there cultivate and study them ; but this cannot be expected to be done soon in a new country, when it has not yet been done in Europe. In the meantime the botanists of every country will hail the appearance of this new *Flora of North America* with satisfaction, and anxiously desire its completion.

Otia Hispanica, seu Delectus Plantarum rariorum aut nondum rite notarum per Hispanias sponte nascentium. Auctore Philippo Barker Webb. Partus I. "A Selection of the rarer or imperfectly known Plants indigenous to Spain. By Philip Barker Webb." 1839. Fol. pp. 8 ; five folio plates, besides an ornamental title. Paris, Brockhouse ; London, Coxhead.

The plates are of *Hólcus cæspitosus* Boiss., *Artemisia granatensis* Boiss., *Cýrtis tribracteolátus* Webb, *Adenocárpus Boissièrei* Webb, and *Salsóla genistóides* Poir. A page of letterpress is devoted to the description of each species ; and, in p. 6, 7, 8., there is a revision of the *Chenopodiáceæ* of Spain. *Adenocárpus* Boissièrei being found between 4000 ft. and 5000 ft. above the level of the sea, along with *Píceá Pinsàpo*, will, in all probability, prove as hardy as that species in British gardens.

Bayldon's Art of valuing Rents and Tillages, and the Tenant's Right on entering and quitting Farms, explained by several Specimens of Valuations, and Remarks on the Cultivation pursued on Soils in different Situations. Adapted to the Use of Landlords, Land-Agents, Appraisers, Farmers, and Tenants. Fifth edition, rewritten and enlarged. By John Donaldson. 8vo. London, 1840.

Bayldon's *Rents and Tillages* have been many years before the public, and the work may now be said to be rewritten by one of the best practical agriculturists in the country. Mr Donaldson is a native of the South of Scotland, and has

had the management of large farms, and extensive estates, such as those of London Castle in Ayrshire, and Donnington Park in Leicestershire, both in Scotland and England. The excellent forms for account-books which he has given at the end of this volume are so superior to those generally published, that we consider them alone worth the price of the book.

Elements of Agricultural Chemistry; in a Course of Lectures for the Board of Agriculture, delivered between 1802 and 1812. By Sir Humphry Davy, Bart., L.L.D., F.R.S., Foreign Associate of the Institute of France, &c. The sixth edition. 8vo. London, 1839.

A standard work, brought down to the present time by Dr. Davy, the author's brother. Any recommendation of this volume is altogether unnecessary. We are glad to see it in a form and at a price which will render it purchasable by those who have hitherto not been able to procure it.

The Sixth Annual Report of the Royal Cornwall Polytechnic Society, 1838. 8vo, pp. 204, seven plates. Falmouth.

Though this volume contains articles chiefly interesting to the engineer, yet there are some which concern the gardener and the farmer. Among these is Polkinhorn's machine for cleansing corn. This machine consists of two parts: first, a vertical axis, carrying a stone which revolves in a wire sieve, and has an opening in the centre for the corn to pass through; and, secondly, a similar axis, carrying a very thickly haired brush. The corn is conducted to the rubbing-stone by a sloping screen, kept in motion; which, in its passage, separates the larger particles of dirt from the corn. The corn is then rubbed in its passage under and round the stone; after which it is rubbed in the brush sieve, and passed through it, thus becoming thoroughly cleansed from smut and other impurities. An easy means of recording the state of the weather is given by our esteemed correspondent Mr. Sopwith, which is very ingenious; and Bain's Duplicator, a simple and correct apparatus for copying plans, maps drawings, &c., is described.

Gatherings from Grave-Yards, particularly those of London; with a concise History of the Modes of Interment among different Nations, from the earliest Periods; and a Detail of dangerous and fatal Results produced by the unwise and revolting Custom of inhuming the Dead in the midst of the Living. By G. A. Walker, Surgeon. 8vo. London, 1840.

This is a book of extraordinary interest; detailing facts, incredible, if they were not proved beyond a doubt. The author is of opinion that our present and past mode of burying the dead has been a vast and constantly operating cause of disease and death for centuries; and it is impossible to read his work without agreeing with him. His book, indeed, ought to be read by every clergyman; and, as gardeners are frequently called on to lend their assistance in laying out cemeteries, they also ought to peruse it. We certainly think that it will have some influence on the government; and we most ardently desire that it may, without loss of time, be the means of doing away altogether the practice of having burial grounds in towns or cities, and that of burying in churches, either in town or country. We conclude with a short extract, and our warmest commendations:—

“The customs of different nations respecting interment show that in every country danger was apprehended from the proximity of the dead to the living. Experience justified the apprehension; and the French government stands preeminent in its arrangements to secure the health and, consequently, the happiness of its members. The dead interred within their cities have been removed; public cemeteries have been established at a distance from towns; sanitary laws have been enacted and rigidly enforced. New York, Pennsylvania, and a few other states, have followed the example; but England yet

retains within the bosom of her population the germs, the nuclei, of diseases; the food, if not the principles, of malignant epidemics. To what cause is this supineness on the part of the British government to be attributed."

MISCELLANEOUS INTELLIGENCE.

ART. I. *General Notices.*

THE Penny Post, as a Gardening Measure.—We cannot sufficiently express our gratitude to Mr. Hill for having devised this measure, and to the present chancellor of the exchequer, Mr. Baring, for having carried it into execution in such a prompt, straight-forward, and efficient manner. What we especially admire in the carrying of it into execution is, that no exclusive privileges have been reserved for any class, from the sovereign to the meanest subject. The humblest journeyman gardener may now send a letter as cheaply as the peer or M. P. his master. But the benefits to be derived from the new system of postage are not confined to the mere cheapness of letters. By introducing the principle of charging by weight, money may be sent to any amount, and in any intermediate sum between a fourpenny-piece and a five pound note. A journeyman gardener in London may enclose a half-crown to his parent in the remotest corner of Ireland for 2*d.*, and five or six packets of seeds may be sent any where for 1*d.* Indeed, with respect to seeds, if a little trouble were taken by the sender, several hundreds of sorts might be sent to any distance within the British Islands for a penny, thus:—Take a sheet of letter paper, and with a rule and pencil divide the second page into squares of half an inch each, leaving a margin all round the page of half an inch. This will give 238 squares for as many different kinds of seeds. On the first page, at the back of each square, write a number; and on the fourth page write a list of the numbers, and the kinds of seeds to be placed on each square. Then, having the seeds ready, and also some paste or gum water, put a coating of paste or gum over one row of squares, and place a few seeds of the kinds corresponding to the numbers and list on each square, gently pressing them down so that they may stick in the paste or gum. Having covered all the squares in this manner, paste or gum the margin which was left all round, and also paste or gum the opposite or third page. Then gently press the two pages together, so as to retain all the seeds in their places; and fold up the letter, and put it in an envelope. If the sender is accustomed to write a small hand, the names might be written on the squares instead of the numbers, and a list and envelope rendered unnecessary. The postage of a letter, so charged, if prepaid, will not exceed a penny. We have tried it to the extent of seventy-three kinds of annuals, which we happened to have by us, and which we sent on January 11th to our correspondent Dr. Edmonston at Barasound, in the Shetland Islands. When the letter arrives, it is not necessary to separate the pages, and pick out the seeds. Tallies with numbers or names being prepared, each square may be clipped off by itself and sown, paper, seeds, and paste together; the moisture of the soil will soon release the seeds, and the gum or paste will serve as nourishment to them.

Scions and cuttings may be sent in letters, being previously painted over with a wash of paste mixed with loam, to prevent evaporation; and even roots and young plants, not even excepting dahlia roots or sets of choice sorts of potatoes. Dried specimens may also be sent from one botanist to another to a great extent, even for 1*d.*, the dimensions of the letter containing them not being larger than that of an octavo page. To nurserymen and florists the new system will be of immense advantage, by enabling them to send their catalogues in every direction; while collectors of plants receiving such catalogues, when they see a kind mentioned in them of which they are doubtful,

may write for a specimen, or for a scion, or for seeds. Another great advantage of the system is, that by means of the adhesive stamp the sender of a letter may not only pay it, but enclose a stamp in order to pay the answer, and thus make sure of it. For example, A sees a particular variety of turnip seed advertised by B, a seedsman in Aberdeen; he encloses a shilling and a fourpenny stamp, and begs to have a shilling's worth of the seed of this turnip by return of post. In short, the sources of benefit and enjoyment of the penny post as a gardening measure are too numerous to describe, even limiting our views to Britain; but, when we consider that other civilised countries speedily imitate all our leading measures, the benefits which will arise from the penny post may be said to be universal. — *Cond.*

Caithness Flagstone. — This promises to be the best flagstone for paths in hot-houses, where stone is used for that purpose, and for the walks of kitchen or flower gardens. Its advantage over every other kind of stone at present used for foot pavements is, that it does not absorb moisture either from the ground beneath, or from the atmosphere above; in consequence of which, dust or dirt never adheres to it, and therefore any footway in the open air so paved can never get into that disagreeable condition called greasy. The Arbroath pavement does not absorb moisture from below, but it wears faster than the Yorkshire pavement. The Caithness pavement has one quality which, it must be acknowledged, is rather against it; that is, it cannot be cut with a chisel, but is sawn on the joints or lines of separation between the laminæ. There is a machine at the quarry in Caithness which both saws and polishes. The kitchen and passages of the house of Sir John Robison of Randolph Crescent, Edinburgh, which is a model for every thing relating to arrangement and comfort, are paved with the Caithness stone, and in the lobby it forms a beautiful mosaic work with marble. An account of this house will be given in the *Supplement to the Encyclopædia of Cottage Architecture*, which will appear in April next. The Caithness stone may be ordered from John Milne, Esq., Architect, 45. Princes Street, Edinburgh; and specimens of it may be seen in our garden. — *Cond.*

Radiation from Trees. — As a proof of the cold produced in solid substances by radiation in a clear atmosphere, Dr. Guérin has ascertained, as had been previously done by Wells, that the temperature of trees and shrubs is much inferior to that of the air. On January 24. 1827, at seven A. M., the air being $11^{\circ} 3'$ cent., the snow adhering to the branches of a cypress and other plants and shrubs was $14^{\circ} 5'$ and 15° , that is to say, $3^{\circ} 5'$ lower than the air. (*Jameson's Edin. Journ.*, Oct., 1830, p. 376.)

Calcareous Concretions on the Bottoms of Steam Boilers, &c. — A simple and very efficacious method is now known of preventing the incrustations in question; it is, to add from 26 lb. to 33 lb. of potatoes to the water in a boiler which consumes from 55 lb. to 66 lb. of coals per hour. The boiler may then be employed for twenty or thirty days without being cleaned, and without any fear of a calcareous deposit. After this time the mud must be thrown away, and the same quantity of potatoes again be added. It appears that the fecula, by dissolving in the water, renders this sufficiently viscous to prevent the deposition of the calcareous matter. Flour would produce the same effect, and much less of it would be required. A few days after the steam boiler designed to heat the Exchange in Paris was brought into use, it was perceived that there was a hole in the bottom. The fire was extinguished; and it was found, upon emptying the boiler, that the metal was burnt in a place where a rag (chiffon) had been deposited, which had been forgotten when the apparatus was set up. (*Foreign Quarterly Review*, April, 1829, p. 317.)

Nurserymen's Catalogues. — We are informed by Mr. Lymburn, president of the Kilmarnock Horticultural Society, that Messrs. Allan, Foulds, and Son, Nurserymen, Kilmarnock, have regulated their nomenclature in conformity with that of our *Arboretum Britannicum*. (*R. L. Dec.* 18. 1839.) The same has been done with an extensive collection of *Cratægus* in the Taunton

Nursery, by Mr. John Young; and by Alexander Pope and Sons of the Handsworth Nursery, Birmingham. — *Cond.*

The Rohan Potato. — A specimen has been sent us by Dr. Mease, from Philadelphia, who states that Mr. Bucl of Albany had 525 lbs. (9 bushels by measure), from 12 lb. planted. The tubers were divided into sets of two eyes each, and the sets planted in hills 4 ft. apart every way. 59 lb., planted by the editor of the *New England Farmer*, produced 790 lb. Various other instances of the productiveness of the Rohan potato are given by Dr. Mease, but, as the variety is already well known in Europe, we forbear quoting them. For feeding cattle the variety promises much from the bulk produced; but it is unfit for the table, and it appears doubtful to us, whether more nutritive matter per acre may not be obtained from several varieties the produce of which is not nearly so bulky. We can send a few sets of this American Rohan potato to any one who will pay the postage. — *Cond.*

ART. II. Foreign Notices.

ITALY.

MONZA, December 28. 1839. — Being apprehensive that the grafts of the *Pópulus fastigiata* fem., which I forwarded last year to Mr. Bentham, had not arrived safely, I sent two months ago a packet of them by a friend of mine, thinking that he was soon to go to London; but he now writes to me from France that he does not intend going to London at all, but will return to Monza. In the letter which accompanied the grafts, I gave an account of the Baron Zanoli's garden; and, knowing how much you are interested in any horticultural notices of my country, I flatter myself I am gratifying your wishes, in sending a copy of it by post. This will be followed in a few days by another notice of the exotic plants which grow in the open air in the two islands of Borromeo in the Lago Maggiore, to which I shall add the representation of an *Altíngia excélsa* [*Araucária excélsa*], which thrives in that delightful climate.

The garden of Baron Zanoli is situated at a short distance from Sesto St. Giovanni, on the high road from Milan to Monza. It is of small extent, but well laid out, and rich in fine plants, such as *Laúrus caroliniána*, *Comptònia asplenifòlia*, *Juniperus lycia*, *Cuprèssus Tournefortii*, *Táxus sibírica*, *T. macrophýlla*, *T. nerifòlia*. There are tufts of *Andrómeda*, among which are *A. arbórea*, *A. calycina*, *A. speciòsa*, *A. acuminàta*, *A. racemòsa*, *A. floribúnda*, &c., azaleas, rhododendrons, kalmias, *Pæðonia Moútan*, *P. Moútan papaveràcea*, *P. Moútan rósea*, &c., which adorn it greatly with their superb flowers; and, as the proprietor cultivates the science with great ability, he arranges the whole in so judicious a manner as to create a magical effect. Among the pines, in which the baron greatly delights, and to complete the collection of which he spares neither money nor pains, there are some species which, for the beauty of their foliage and fruit, perfectly enchant me. Your admirable *Arboretum et Fruticetum Britannicum* served him as a guide, and by the help of this work he has compiled so ingenious a catalogue, that, by referring to it, he can tell in an instant the species which he possesses, and those which are still wanting to complete his collection. He intends, when his pines have attained considerable age and strength, to have portraits of them made, and to publish the figures, with an accompanying description of them. May his love for arboriculture serve as an incentive to my rich compatriots! Here follows the list of the species which he possesses: —

Pinus sylvéstris, *P. s. horizontalis*, *P. s. uncinàta*, *P. s. rigénsis*, *P. s. genevénsis*, *P. s. genevénsis brevifòlia*, *P. s. scariòsa*, *P. s. intermèdia*, *P. pumilio*, *P. p. Físcheri*, *P. p. Mùghus*, *P. Banksiàna*, *P. inops*, *P. mitis*, *P. púngens*, *P. Laricio*, *P. L. corsicàna*, *P. L. caramànica*, *P. L. calábrica*, *P. L. austriaca*, *P. L. pyrenàica*, *P. L. altíssima*, *P. L. taúrica*, 6 ft. high, *P. L. Pallasiàna*, 3 ft. high, *P. L. resinòsa*, *P. Pináster*, *P. P. marítima mìnor*, *P. P. ma-*

rítima màjor, *P. P. nepalénsis*, 2 ft. high, *P. P. Massoniàna*, 3 ft. high, *P. Pinea*, *P. halepénsis*, *P. brútià*, *P. nootkaténsis*, 2 ft. high, *P. monti na*, *P. uralénsis*, 1½ ft. high, *P. romàna*, 6 ft. high, *P. echinàta*, *P. monteriénis* [?], 6 ft. high, *P. embrunénsis* [?], 4 ft. high, *P. racemòsa*, *P. Tæ'da*, *P. rígida*, *P. Sabiniàna màjor*, 4 ft. high, *P. S. mìnor*, 2 ft. high, *P. S. var.* 1½ ft. high, *P. Colúteri*, 3 ft. high, *P. longifòlia*, 4 ft. high, *P. Gerardiàna*, 2 ft. high, *P. austràlis*, *P. excélsa*, 2 ft. high, *P. canariénsis*, *P. sinénsis*, 12 ft. high, *P. insígnis*, 2 ft. high, *P. Llaveàna*, 1½ ft. high, *P. Michaúxii*, 4 ft. high, *P. Cembra*, *P. Stròbus*, *P. S. compréssa*, 1½ ft. high, *P. S. elàta*, 2 ft. high, *P. S. excélsa*, 2 ft. high, *P. S. Lambertiàna*, 1½ ft. high, *P. S. monticòla*, 1½ ft. high. *A. bies excélsa*, *A. e. pèndula*, *A. e. Claubrasiliàna*, *A. álba*, *A. á. nana*, *A. nigra*, *A. n. rùbra*, *A. n. cærùlea*, *A. Smithiàna*, 2 ft. high, *A. orientàlis*, 2 ft. high, *A. Douglàsü*, 2 ft. high, *A. Menzièsi*, 2 ft. high, *A. canadénsis*, *A. monocaulon* [?], 2½ ft. high, *Picea pectinàta*, *P. cinèrea*, *P. Pìchta*, 2 ft. high, *P. balsàmea*, *P. Fraseri*, *P. nóbilis*, 1½ ft. high, *P. Webbiàna*, 5 ft. high, *P. Píndrow*, 3 ft. high, *P. reli-giòsa*, 2 ft. high, *P. Nòvæ Hollandiæ*, 2 ft. high, *P. Fórsteri*, 2 ft. high, *P. Hudsoniàna*, 3 ft. high. *Làrix europæ'a*, *L. e. pèndula*, *L. e. fl. rùbro*, *L. e. fl. álbo*, *L. e. sibìrica*, *L. e. dahùrica*, 2 ft. high, *L. Americàna*, 12 ft. high, *L. a. pèndula*, 2 ft. high. *Cèdrus Libàni*, *C. Deodàra*, 4 ft. high. *Araucària brasiliàna*, *A. excélsa*. (*Altingia excélsa*), *A. Cunninghàmia*. *Cunninghàmia sinénsis*. I have given the height of those only which I consider the most rare.

The Marquis Cosmo Ridolfi of Florence continues to obtain abundant produce from the batata (*Convolvulus Batàtas*, vel *Ipomœa Batàtas*), so much so, that this year he has sold some hundred pounds' weight of them. He has besides found that this climber is very useful as fodder, as its numerous branches, which contain a great quantity of starch, furnish abundant and excellent food, best adapted for cows, as it considerably augments the quantity of milk, at the same time rendering it of better quality. — *Giuseppe Manelli*.

RUSSIA.

Riga, Dec. 15. 1839.—With regard to what is new in horticulture and botany, you are too well informed of all that is interesting on these subjects, for me to furnish you any thing worthy of notice. However, I cannot help mentioning a shrub which we received from the Caucasus a year ago. It is a *Ribes*, which an officer, a friend of ours, sent us; and he says the fruit is black, like that of *Ribes nigrum*, with the taste of the common currant (*Ribes rùbrum*). We have not yet been able to prove the veracity of the assertion, as it has not yet borne fruit; but, as the person who sent it can have no motive for leading us into error, we feel inclined to give credit to it. I hope it will have fruit next year, and, as I know that such a shrub is not yet cultivated in Europe, we will be most anxious to send you a detailed description of it, so that you may insert it in your Magazine. With respect to the leaves, and the general appearance of the shrub, it is exactly a medium between *R. nigrum* and *R. rùbrum*; and the leaves have a great resemblance to *R. nigrum*, but they have not the same smell. I will send you a full description of it, if it answers our expectations. We have received some other plants which I do not remember to have seen in London, but they may have been introduced since I was there; such as *Caryóptis mongólica*, a beautiful undershrub, said to have blue flowers, resembling those of the *Vitex Ágnus cástus*. We have also two *lysimachias*, I do not know if they are natives of Russia; *Lysimàchia atropurpùrea* [*Lubínia atropurpùrea*, a Cape perennial figured in Sweet's *B. F. G.*], with purple flowers; and *Lysimàchia brachýstachys*, from China, with white flowers. We are so far behind England in point of culture, that it is out of my power to communicate any thing of the most trifling interest, but there is one kind of culture that I did not see so successful as with us; and that is of the *Cheiránthus ànnuus*. When travelling through France and Germany, I never saw such fine stocks as those belonging to my father, who bestows the greatest care upon them. He is now very celebrated for them, and we send some of them to England, and to Scotland particularly, every year. There

are Scotch captains who never leave Riga without taking some with them. I regret exceedingly that I did not send you some along with the caviare. You would have been convinced of the fact by sowing them yourself, or by giving them to your friends. Although England has so many interesting plants, I always think that the stock deserves a place in every garden as an ornamental plant. Next year I shall take the liberty of sending you some seeds, and we will be very much pleased if you will make a trial of them.

The past summer was wet, but the autumn was very dry and pretty warm. The vines on the walls of our house ripened their fruit very well, which is not the case every year. The winter has not been severe as yet; there has, however, been 13° of Reaumur, and a little snow.

With the caviare you will receive a jar of little fishes, which are called here kiloströmlinge; they are taken at Rival, and preserved by laying them in alternate layers with pepper and other spices, including the leaves of the *Laurus nobilis*. They are sent in these glass jars to every part of Europe, being used like the little fishes called sardines (*Clupea Melletta* L., *Engraulis Melletta* Cuv.), and are esteemed a great delicacy, particularly at Paris. — *F. E. Wagner.*

The caviare or caviar, our readers are aware, is the roe of the sturgeon, esteemed a very great delicacy by most people. It has long been sent to London in a compressed and dried state, but has lately been sent quite fresh, as it is used in Riga and Petersburg. It is an admirable substitute either for butter or meat, or both, at breakfast, and for soup or fish at dinner. There is nothing in the way of fish that we consider at all equal to it. At present it is only imported by a few Italian warehousemen, and the only one we happen to know, who does so, is Mr. Ball, 81. New Bond Street, who sells it in small casks at 15s. each; each cask containing about 3 lb. The kiloströmlinges, or, as the English in Riga call them, kilkie, are nothing more than our sprats (*Clupea Sprattus* L.), and they form an excellent substitute for the anchovy or sprat of the South of Europe. They may also be obtained of Mr. Ball. — *Cond.*

ART. III. Domestic Notices.

ENGLAND.

SPECIMENS of Trees and Shrubs received from the Saubridgeworth Nursery.—*Mahonia Aquifolium*, *M. fascicularis*, and Mr. Rivers's new hybrid *M. repens-fascicularis*, as we propose to call it, between the last species and *M. repens*: the leaflets of this hybrid are much larger than those of *M. Aquifolium*, and they are not quite so glaucous beneath as in that species. *Gleditschia micracantha*: young wood very thorny; thorns small, and yet branched. *G. sinensis*, raised from seeds received from France: "a slow-growing variety or species totally different from that described in the *Arboretum*." Mr. Rivers has sent us a rooted plant of this *Gleditschia*, which we shall plant and examine when it is in leaf. A shoot of the large-leaved European lime: vigorous, with large buds, but clearly nothing more than *Tilia europæa grandifolia*. A shoot of *Tilia americana*: readily distinguished from the other by its rough grey speckled bark. *Quercus Flex*, several varieties: one of the large round-leaved, with the leaves 3½ in. long, and 2½ in. broad; another the small round-leaved, with leaves not above half the size, but of the same proportion as to length and breadth. A narrow-leaved variety, called the willow-leaved *Quercus heterophylla*, from New Holland, which appears to us to be *Quercus virens*, a native of North America; curled-leaved Lucombe oak, a different variety from that which we received from Mr. Pince; and the broad-leaved Fulham oak, with leaves rather broader than the species: one of these measures 3½ in. broad, and 5½ in. long. Turner's evergreen oak, a very handsome specimen with large fine deep green leaves. *Quercus fastigiata viridis*; named *viridis*, we presume, from the green colour of the young

shoots. *Quercus rugosa* Willd. (*Arb. Brit.*, p. 1941.), a species of which various worked plants have lately been imported from the Continent, and are to be obtained in different nurseries.—*Cond.*

Folding Swine among Oaks. — A paragraph having gone the round of the newspapers on this subject, we applied to the Duke of Portland to ascertain how far it was true. His Grace states in answer, that thirty swine were folded under some oaks thirty years old which did not grow well, and fatted under their cover. The effect of their manure, His Grace informs us, will probably not be seen for a year or two; but the same process having been applied some years before under similar circumstances, was found to have a very good effect. — *Scott Portland. Welbeck, Jan. 8. 1840.*

A Wreath of Flowers formed from dried Specimens was shown us some months ago by Mrs. Bateman of Litchurch Villa, Derby; a lady remarkably fond of flowers, and possessing much skill and taste in drying them and displaying them on paper. Mrs. Bateman uses no extraordinary means of drying, but takes care to gather the flowers when they are perfectly free from exterior moisture, and to place them immediately between the leaves of a book, where they soon dry, retaining their colours. The next process in forming a wreath is to make a selection of leaves and forms, so as to combine in one wreath as great a variety of forms and colours as possible, without any apparent incongruity of either; and in this part of the process Mrs. Bateman excels, displaying a degree of taste which one only expects to find in a practised artist or decorator. One of the wreaths was exhibited at a meeting of the Horticultural Society, Jan. 20., and was much admired.—*Cond.*

The Bokhara Clover. — The penny post is a great and glorious measure; and one, the advantages of which will not and cannot be appreciated until the people have become fully acquainted with the mode of working it. In a gardening point of view, consider the immense privilege thus conferred on us amateurs, as well as professionalists, by the establishment of the principle of weight, which enables us to interchange small packets of seeds, and even small roots and slips of plants. The Bokhara clover, for instance, you were kind enough to send me last year, of which I have saved a few seeds; and which I shall be equally ready to distribute (so far as they will go) as I was to receive, to any one disposed to make trial of it. I agree, in the main, with all that Mr. Gorrie has said of it, and believe it to be a valuable addition to our green crops for cutting and stall feeding; a conclusion, I admit, I was very slow to come to, because I knew, from experience, that the melilot tribe in general is by no means relished by cattle. It has every appearance of a perennial, and the roots are stronger and thicker than those of lucerne. The weight per acre, too, must, I should imagine, far exceed that of a crop of lucerne; but time alone can determine its real value. I have taken up and transplanted my little patch of roots, some of which I have given to a neighbour, who was struck with its appearance last autumn. — *S. Taylor. Whittington, Stoke Ferry, Norfolk, Jan. 10. 1840.*

Yucca gloriosa in the garden of Sir R. E. Eden, Bart., Windlestone Castle, near Durham, last autumn produced a flower stem 14 ft. 6 in. high, on which 673 flowers expanded in the course of three weeks. (*York Herald*, as quoted in *Morn. Chron.*, Jan. 9. 1840.)

Berries of Black Hamburg Grapes, measuring 4 in. in circumference, have lately been grown by Thomas Clarke, jun., in a metallic house erected by his father, the eminent hot-house builder of Birmingham. — *T. C., jun. Birmingham, Dec. 6. 1839.*

The Knepp Castle Kidney Potato. — This is a large potato of the kidney kind, very mealy, and superior in flavour to any kidney which we have before tasted. The taste of the farina, and also its pure white, come near those of the West India yam. The eyes of the tubers are remarkably full, in consequence of which very little waste is made in paring them before boiling. The sample was sent us by Sir C. M. Burrell, Bart., M.P., in whose garden at Knepp Castle, near Horsham, Sussex, they have been grown for twenty years, without

degenerating in the slightest degree. We have sent sets by post to several correspondents, and some in packets to others. — *Cond.*

Pearson's Draining Plough has been used extensively by Sir C. M. Burrell in clayey soil, at Knepp Castle, near Horsham, in Sussex, by which the land has been increased in value one third. The drains are made in parallel lines about $8\frac{1}{2}$ ft. apart; they are from 24 in. to 26 in. deep; a tile is laid in the bottom; and, charging at the rate of 2s. a day per horse, the total cost, the tiles being made on the spot, is about 52s. per acre. — *C. M. B. Dec. 1839.*

SCOTLAND.

The Ligneous Flora of the Shetland Islands. — Dr. Edmonston of Baltasound has sent us a list of plants observed by his son Thomas, a boy 14 years of age, in the Shetland Islands, accompanied by dried specimens of the whole. This is the first attempt at a regular flora of these islands, and it is supposed to include nearly all the species which are indigenous there. The list is arranged, first according to the Linnæan system, with the habitats; and secondly, according to the natural system, with the names only. We regret we have not room for details, but we may state that the total number of species is 250; and that the ligneous plants are as follows: — *Leguminosæ*: *Ulex europæa*. *Araliæ*: *Hédera Hélix*. *Caprifoliæ*: *Loníçera Periclymenum*. *Rosacæ*: *Sórbus aucupária*, *Rósa tomentósa*, *Cratægus Oxyacántha*. *Vaccinæ*: *Vaccínium Myrtillus*. *Ericæ*: *Azàlea procumbens*, *Arctostáphylos Uva úrsi*, *A. alpina*, *Erica cinèrea*, *E. Tétralix*, *Callúna vulgáris*. *Empétreæ*: *E'mpetrum nigrum*. *Amentacæ*: *Bétula álba*, *Sálix fúscá*, *S. auríta*, *S. aquática*, *S. herbácea*. *Cupressinæ*: *Juníperus communis*. In all 20 species. Let us hope that some patriotic individual, native of, or settled in, Shetland, will multiply the ligneous flora ten or twenty fold, which now, by the penny post, he might do by procuring seeds from the London or Edinburgh seedsmen. A horticultural society established in Shetland, or an arboretum planted there, would be delightful news. We have sent the specimens and the lists to Mr. Charlesworth, the conductor of the *Magazine of Natural History*. — *Cond.*

Subsoil-Ploughing. — Mr. Smith of Deanston had offered a set of premiums to ploughmen for expertness and effect in subsoil-ploughing, and a match took place accordingly, on the 12th of December last, in the neighbourhood of Stirling, at which four prizes were awarded. The ground was divided into different lots, and these were drawn for by the candidates. The ploughs were of different forms, but in general heavy, with a long beam, and they were generally drawn by four horses. "This exhibition, upon the whole, did great credit to the ploughmen, and showed again forcibly to the public the power and efficacy of the subsoil plough, in producing, at a cheap rate, a thorough movement of the subsoil. The efficacy of such movement in improving the productiveness of the soil was most apparent in an adjoining field, where Mr. Gray pointed out to those present two equal divisions, the whole having been thoroughly drained, and one of the divisions having been subsoiled, while the other remained in its original state." (*Stirling Journal*, Jan. 10.) — *Cond.*

ART. IV. Retrospective Criticism.

NEW Plants raised in the Birmingham Botanic Garden. (Gard. Mag., 1839, p. 626.) — The list of plants in a living state in this garden, with their native country and year of introduction, which was handed to you when you last visited us, I had no intention of claiming as being all raised here. The appropriately named *Begónia macrophýlla*, with a leaf now measuring 21 in. long and 15 in. broad, was first grown by George Barker, Esq., of Springfield, near Birmingham, from tubers imported by himself from Mexico. The *Cheilanthes farinósa* was raised from seeds obtained from a dried frond from the East Indies, by J. Riley, Esq., Papplewick, near Nottingham; who has been very successful, at different times, in raising ferns from seeds obtained

from foreign specimens. — *David Cameron. Birmingham Botanic Garden, Dec. 14., 1839.*

Proportion of Hot-Water Pipe required for heating. — In the *Gardener's Magazine* for 1839, p. 565., it is stated that the rule there given may safely be taken by gardeners, &c. Now this rule gives only one twentieth part enough for stoves, and about one fourteenth part enough for green-houses. I speak from experience and calculation. You will see the extravagance of the rule by the following application of it. If the pipes that are about to be laid down at Chatsworth, in the new conservatory, were laid in a common hot-house, say 12 ft. wide, 12 ft. high at back, and 5 ft. at front, then, according to the rule, they would heat green-houses extending over twenty-four acres; and, if the houses were in one line, they would be nearly eighteen miles long. — *Alexander Forsyth. Alton Towers, Cheadle, Staffordshire, Dec. 19. 1839.*

The Grand Conservatory at Chatsworth. — In the *Gardener's Magazine* for 1839, p. 450., the Chatsworth Conservatory is said to be executed "with a degree of taste, science, and economy that will surprise every one." Leaving the science, elegance, &c., in abler hands, I only want to show you that the ridge-and-furrow roof is not economical. I was not fortunate enough to see Counsellor Harrison's ridge-and-furrow hot-houses at Cheshunt, although I lived some years in that neighbourhood, which you praised so much in the *Gardener's Magazine* for December, 1839; but I have seen the originals at Chatsworth, and from them I will make my calculations: and, lest you or any one should construe this into an ill-natured criticism on the works at Chatsworth, I will just premise that I called there in the autumn, and experienced the greatest kindness; and was quite astonished at the extent, variety, and high keeping of that most interesting garden. It is, therefore, the system of building hot-houses in ridges and furrows that I object to, as being anything but economical, and not against the princely garden structures erected by the noble duke, under the direction of Mr. Paxton. It is a standing principle among those who study economical hot-house-building, that a rood of glass should roof a rood of ground, and, *ergo*, an acre of ground might be roofed by an acre of glass. Now, let us take the new conservatory at Chatsworth for an example, and suppose its section represented by a circle, of which the side ailes are quadrants, and the centre aile a semicircle. It will thus form a circle, whose diameter will be one half of the real width of the house. Suppose, then, the diameter 1; then the width of the house will be 2, and the circumference of the circle, or the length over the roof across the house, will be 3; and, at the lowest rate, the ends and extras will amount to one part more. This gives just double the area of the floor, for a roof whose section is as above. Now for the furrows; and suppose them to form with the horizon the three sides of an equilateral triangle, you will see that this just doubles it again. So I conclude that, if this rough calculation be anything near the truth, this roof would cover nearly four acres of glass, certainly not less than three, to light and heat one acre of land; and, leaving the circular section altogether out of the question, the ridge and furrow alone would take twice the glass necessary for a plain roof, which is found to answer every purpose quite as well; and, certainly, in houses of ordinary shape and size, like Mr. Harrison's, it is more simple and rational. — *Idem.*

Paring the Verges of Walks. — In different places in the *Gardener's Magazine*, you say verges of walks should be clipped and kept green, and not pared to the raw earth. Now this is not fair argument, because, when the verge is deep enough to have raw earth so conspicuous, the walk wants more gravel to raise it up to within 1 in. of the grass level; and if the verges of walks thus filled are not nicely pared every spring, as well to regulate the lines and curves as to cut the roots of grass, which otherwise would intrude upon the gravel, they would cause fifty per cent more labour to keep the walks neat through the summer. A deep raw edge is detestable in a garden, and a deep green edge is worse where labour is scarce, as it takes great labour to clip it, and gives the walks a sunken and worn out appearance. Think not by this that I

approve of paring 2 or 3 inches of the verge every time. It is perfectly possible to pare for seven years, and yet not widen the walk 1 in. after all; and those gardeners that cannot keep a walk without widening it, and keep verges with very little clipping, should read, mark, and learn. If I had leisure, I should like to hint at various items, such as Counsellor Harrison's coal-box, an article, doubtless from his own design, now employed as a hot-house boiler, &c.; but this, and various matters, I must defer for the present. — *Alexander Forsyth. Dec. 19. 1839.*

Native Scotch Pine. — After your able article in the *Arboretum* on this subject, little need be added; yet I may mention it as my opinion, founded on observation, viz., that the three varieties of the late Mr. Don of Forfar, that is, those with upright, horizontal, and pendent branches, merely denote the youth, maturity, and decay of the tree. The horizontal or mature state, of course, contains the best timber: decaying trees will produce most seed; but the most vigorous seedlings will be the produce of cones taken from trees in a state of maturity. — *R. Lyburn. Kilmarnock, Dec., 1839.*

ART. V. *Queries and Answers.*

NAMES of Insects. — The species of wasp of which the nest was formed in the branches of the larch fir is the *Vespa británnica* of Dr. Leach, so called because this species has not yet been found on the Continent. The insects among the leguminous seeds are specimens of one of the many species of *Bruchus*, which feed, both in the larva and perfect state, on the seeds of these plants. Those on the *Clíánthus puníceus* are a species of *Coccus*, which it would be necessary to study in a living state before their specific name could be determined. The same remark may also be made on those sent by J. B. W., which infest the pear and the manettia. All these species are doubtless distinct. — *J. O. W. Dec. 31. 1839.*

The Yellow Dutch Turnip. — This turnip, so highly recommended in the early editions of your *Encyclopædia of Gardening*, I cannot find in the catalogues of either provincial or London seedsmen. Can you inform me where it may be procured? — *N. T.*

The yellow Dutch turnip is nothing more than the common yellow turnip; the seed of which, having formerly been chiefly procured from Holland, thus obtained the name of Dutch. It is little grown in England in gardens, but much esteemed and generally cultivated in Scotland. It may be had from most London and all Edinburgh seedsmen. By enclosing 6d. and a twopenny stamp in a prepaid penny letter to Mr. Sang of Kirkaldy, a packet of the genuine Dutch yellow turnip may be had, by return of post, sufficient for two sowings in an ordinary garden. — *Cond.*

ART. VI. *Obituary.*

DEATH of Baron Jacquin. — *Vienna, Dec. 11.* Universal regret is excited by the death of Baron von Jacquin, who has been carried off by an apoplectic fit, at the age of 74. His celebrated father attained the age of 90. The loss of the learned world will be the more severely felt, as his house was, for a long series of years, the rendezvous of all the most eminent characters in literature and science. He was, in every respect, a highly accomplished and most honourable man. (*Leipsic Allgemeine Zeitung*, as quoted in the *Times* of Dec. 23. 1839.) Since we commenced the *Gardener's Magazine*, we have received many favours from this excellent man; the last of which was a beautiful drawing of *Cýtisis Wéldenî*, which arrived simultaneously with the above account of his death. — *Cond.*

THE
GARDENER'S MAGAZINE,
MARCH, 1840.

ORIGINAL COMMUNICATIONS.

ART. I. *Notice of a Visit to Wortley Hall.* By J. B. W.

WORTLEY HALL, the seat of Lord Wharnclyff, is about eight miles north-west of Sheffield, on the Penistone road. The country thereabout is beautifully diversified with hill, dale, and wood; and the soil, although apparently not of the best quality, is well adapted for forest trees, oak especially, which in some of the neighbouring woods is very fine timber. The house at Wortley Hall stands on the side of some rising ground at the verge of the park; and, from its elevated position, overlooks nearly the whole of the park, as well as an extensive tract of country towards the east and south-east; in other directions the view is very limited. The mansion is a handsome stone building, of modern construction; having, I believe, been built within the last half century. In the disposition of the approach road some of the errors deprecated in former parts of this Magazine are observable. A high ridge of ground rises considerably above the house, in the direction from which carriages approach it; the road, therefore, descends abruptly instead of ascending to the mansion, whereby its apparent height, and consequently its dignity, are lowered. Perhaps, however, this defective arrangement is rather attributable to the situation and plan of the house. A low and narrow stone terrace immediately connects the house with the pleasure-grounds, which extend round three sides of the house; on the other side the various offices are placed. In general arrangement, and also in many minor details, these grounds might be greatly altered for the better: one obvious improvement would be, the removal of a heavy mass of laurels that disfigures the lawn on the south front of the house. There is no regular flower-garden, but small plots, widely separated, are interspersed through the pleasure-ground; one in the geometrical style, in which the beds are very properly edged with stone, in preference to box or flowering plants, has been recently formed. The green-house, which stands in a sheltered corner of the pleasure-ground, is of a style by no means

common in plant structures; and which, whatever may be its advantages in other respects, has certainly no great architectural beauty to recommend it. It is long and narrow, with a span roof, some ten or twelve feet high at the crown; and, as much space is lost in the interior by the fantastical form of the stage, it perhaps contains the fewest plants, in proportion to the surface of glass, of any plans that have yet been contrived. In front of this green-house there is a small flower-garden, in which handsome half-hardy plants, such as verbenas, petunias, lobelias, &c., together with the most showy annuals, are grown; and the whole plot is bounded by a semicircular line of dahlias. The effect of this garden must be very pleasing when in the height of its beauty; and the plan is worthy of imitation in similar situations. Behind the green-house, in an enclosed space, a botanic stove has lately been built on the same plan as the green-house, except the interior arrangement, which, in this house, is well contrived; the larger plants being placed on a raised bed along the middle of the house, and the less vigorous species ranged on wide shelves fixed along the sides. It is intended to train climbers upon the rafters, to make a partial shade for the *Orchidaceæ* and ferns, of which a collection is begun. An insignificant plant-house stands in a nook of the shrubbery, at some distance from those above mentioned: this, if removed to a more appropriate situation, might be of some use; but in its present place it is merely an eyesore. Another reprehensible structure is a kind of framework for climbing roses, having in the centre, and being also surrounded by, raised beds of earth, supported by stakes driven into the ground, in the true cockney style. On each side of the principal walk leading to the kitchen-garden, there is a wide flower-border, in which dahlias, backed by a row of hollyhocks and fronted by showy annuals, are grown in summer: this, likewise, is a feature worthy of adoption in places where such a vista would not be at variance with the general arrangement of the grounds; for a walk along an avenue of beautiful plants must be productive of a high degree of pleasure, even to those who do not admire flowers individually.

The only water I observed near the mansion is a sort of basin in the pleasure-ground, from which the house and offices are supplied. This basin might have been made ornamental, had its margin been varied so as to resemble a natural pond, instead of which, it is quite as artificial in character as the reservoir in the Green Park, being similar in shape, and moreover edged with dressed stones, which rise eight or nine inches above the level of the ground: the edging is intended to prevent reptiles from getting into the water.

There are but few fine trees in these grounds; I observed, however, a very large oak at one end of the basin, and in an-

other place an old Spanish chestnut, a tree which is seldom seen of large size in the North of England. In a sheltered corner near the house are two large plants of the Double red Camellia, which have stood out several winters without any protection; and although much injured in the winter of 1837-8, they are now growing vigorously. A plant of the Double white variety, that grew between the other two, was totally killed in that winter; thus confirming the remark of the Honourable W. Herbert (quoted in Dr. Lindley's excellent paper on the effect of the severe cold on plants, lately published in the *Horticultural Transactions*), that some varieties of *Camellia* are much hardier than others.

In the kitchen-garden, which is conveniently situated close to the stables and near the mansion, there are several forcing-houses, together with some useful pits for the culture of pine-apples and melons. In one of the vineries a few imperfect berries remained of the Wortley Hall seedling grape, which is said to have been originated at this place; but I am inclined to think, judging, however, from an imperfect specimen of the fruit, that this grape is not absolutely distinct from the Black Muscadel of the *Horticultural Society's Catalogue*, otherwise known as the Black Raisin; and, if I do not greatly mistake, as the *Eshcollata supérba* of Money. In the wood and leaves, all the plants I have seen under the above names so closely resemble each other, that I cannot perceive any essential difference. Whilst upon the subject of grapes, I will take this opportunity of recommending, as an excellent late variety, the Oldaker's West's St. Peter's of the *Hort. Soc. Cat.*, and of this Magazine. In Mrs. Lawrence's garden, at Studley, I lately saw fruit of this variety hanging in the same house with fruit of the Black Hamburg, to which the St. Peter's was then decidedly superior in condition, and consequently likely to keep till a later period; in fact, Mr. Cuthbertson has such confidence in its merits, that he intends to destroy the Hamburgs and other sorts in his late house, and to replace them with the St. Peter's. At Chatsworth, there is a whole house of the St. Peter's, which in the end of November appeared likely to keep, at least, two or three months later. Is this grape the true St. Peter's? or is it a distinct sort, and "St. Peter's" merely a synonyme of the Black Prince? At all events, its present absurd name of Oldaker's West's St. Peter's ought to be immediately changed or curtailed.

When the present gardener (Mr. Law) came to this place, two years ago, the pine plants were eaten up by the white scale, and, as the best and cheapest method of cure, they were all consigned to the dunghill, and a new stock procured, which are now healthy and thriving.

A peach-house is glazed on the plan patented by Mr.

Harrison, which, I believe, was noticed in detail in this Magazine, when first brought before the public. Its appearance exteriorly is very neat, but I was told that the plan does not answer well in practice, owing to the difficulty of taking the copper fastenings out of the bars, when repairs are necessary. Here it was that Harrison (who was many years gardener at Wortley) wrote his celebrated *Treatise on Fruit Trees*; and, knowing this, I, of course, expected to find the wall trees, if not absolutely models of perfection, at least much superior to those usually seen in gardens; instead of this being the case, however, I found some of the most unsightly and ill-managed specimens of pruning and training that ever disgraced a gentleman's wall; so infinitely wide is the difference between theory and practice.

The gardens altogether appear to have been formerly neglected; but, under the able superintendence of Mr. Law, they will doubtless be greatly improved.

Herefordshire, Jan. 14. 1840.

ART. II. *The Examination of Gardeners in Denmark.*

By A. WEILBACH.

AN examination for gardeners has been established in Denmark since the year 1811, an account of which is given by Mr. Lindegaard, in the *Gard. Mag.* for 1828, p. 76. This system of examination was in 1833 considerably altered, as will be seen by the following statement.

The examination is divided into two classes: I. for ordinary gardeners; and II. for artist-gardeners.

I. The examination for *ordinary gardeners* consists in:

a. A practical trial, by which the gardener is required to show the necessary skill in the pruning and grafting of trees, the knowledge of seeds of culinary vegetables, and the quantity of each of these required to a certain piece of ground; and, lastly, the knowledge of the common fruits and flowers. And,

b. A theoretical trial, which is only verbal, and where the gardeners are required to understand:

1. The laying out and managing of a common kitchen-garden; under which are included the raising of seeds, the management of hot-beds, and the culture of melons.
2. The laying out and management of a stock-ground and an orchard; under which is included the training of trees to walls.
3. The culture of the common ornamental plants in the open air, as well as in pots.

- II. The examination for *artist gardeners*, which is a condition for being royal gardener, consists in :
- a. *A practical trial*, similar to the above mentioned, but on a larger scale.
 - b. *A theoretical trial in writing*, by which the gardeners have to answer six questions in the different branches of gardening, viz. three general and three special questions ; and at the same time draw a sketch of the laying out of a given piece of ground.
 - c. *A verbal theoretical trial*, by which the gardeners are required to show that they have :
 1. A knowledge of the management and composition of the soil.
 2. A knowledge of botany, especially those parts of botany which are essential for a gardener to know.
 3. Land-surveying, as far as it is necessary for a gardener.
 4. The laying out and management of a kitchen-garden on a larger scale than is required for an ordinary gardener.
 5. The laying out and management of an extensive orchard ; together with the knowledge of the different varieties of fruits.
 6. The laying out and management of a large flower-garden with rare flowers, which the gardener must know, and whose cultivation he must understand.
 7. The management of a forcing-garden, consisting of fruits, culinary vegetables, and flowers ; together with the construction of forcing-houses and pits.
 8. The culture of hot-house and green-house plants, and the construction of such houses.
 9. Every thing required for the laying out of grounds on an extensive scale.
 10. The management of a stock ground for fruit trees, and other trees and shrubs, on a large scale.

The gardeners are examined in the different divisions, in the same order as they are here enumerated ; and if they do not succeed in the first or second trial, they will not be allowed to proceed to the following one, but be rejected. There are five examiners, viz. four royal gardeners, and the professor of botany. The questions and answers are put down in a book by a secretary, and are preserved together with the written answers.

The examination is public, and every body is allowed to attend it. It takes place in the month of September ; this time of the year being preferred as the most convenient for gardeners entering on situations.

These are the alterations made in the former system of exa-

mination; in other respects it is quite in the same manner as mentioned by M. Lindegaard, in the volume and page above quoted.

Horticultural Society's Garden, Dec., 1839.

THE above is given exactly as translated from the Danish by M. Weilbach, a most intelligent young Danish gardener now in England for his improvement, and who came to us strongly recommended by the celebrated writer on botanical geography, Professor Schouw. — *Cond.*

ART. III. *An effectual Mode of destroying the Aphis lanigera, or Woolly Blight, on Apple Trees.* By N. T.

THERE are many methods for destroying the mealy insect, *Aphis lanigera*, on apple trees; some of which are troublesome, and some dirty ones. I here send you a more simple one; which you may perhaps think worth inserting in your *Gardener's Magazine*. It is the brown impure pyroligneous acid; which may be had at the manufactory of this acid at a trifling cost. I have an apple tree which was nearly destroyed by this insect: by brushing it once over with the acid, about three or four years ago, the insects immediately disappeared. A few days after, some more made their appearance, which were perhaps so protected in the cracks of the rough bark, that the acid had not reached them. Having brushed these over, they have never appeared since.

This acid may also be applied, with the same effect, for the destruction of all other insects on the stems and branches of plants; but it cannot be safely applied to those on the leaves or flowers. For the destruction of these, the mixture [chiefly tobacco water] in Vol. VI. for 1830, p. 553., may be used, which is equally efficacious, as I had long experienced before I sent you the receipt. It has been said, that tobacco water itself will answer the same purpose; but I find it will not answer by immersion, except when used hot, and it is more expensive; whereas the other, in which a small quantity of tobacco water is used, and the cost of the other ingredients is a mere trifle, may be used either hot or cold, with the same effect.

Jan. 11. 1840.

ART. IV. *A Mode of destroying the White Bug in Hot-houses.* By W. ANDERSON, F.L.S., Curator of the Chelsea Botanic Garden.

I KNOW of no better method to publish any thing of importance in gardening, than through your widely circulating *Gar-*

dener's Magazine. You know that Mr. J. T. Mackay, of the Botanic Garden, Dublin, was seeing many gardens in Flanders last summer. In his return home he called here; and, when conversing on what he had seen, he said, he "had not learned any thing new:" after a little, however, he said, "One thing I noticed that was new; I had not seen the white bug, and, after several enquiries, I found that they syringed their plants with lime water." Of course I must try the truth of this prescription; but I have been at a loss how to economise the hot lime, knowing how little of it the water carries, and to have it always fresh when wanted. I consulted with the chemical gentlemen at the Hall, where it was proposed to mix a little black sulphur with the lime before being put into the water.

Our mode of preparing it is in this way. We have a large garden-pot, or a pail, into which we put half a pint of pulverised Dorking lime, with about half an ounce of black sulphur: after being well mixed, we add four gallons of water, stir it well, then let it settle, and, when clear, we take M'Dougal's syringe, and throw it under the leaves, by syringing from the back path of the house first, then the front; and, as the lime will take another dose of water, we use this in the second hot-house. We have been using this syringing for the last three months, and there is not a bug, red spider, or thrips to be seen in either house.

It must also be observed, that although the above is good, yet it is requisite to look to such plants, or parts of plants, as the syringe never reaches; but M'Dougal's inverted syringe, used with care, will do much. We syringe twice a week with this lime water, and once or twice a week with pure water, just about four o'clock, when the fire-heat rises in the houses for the night. We expect soon to leave off this lime water, as we have subdued all our noxious insects for the present. I expect it will also be useful for the American white bug on the apple trees; and I wish that some of your readers would try it with a syringe.

Chelsea Botanic Garden, Jan. 20. 1840.

ART. V. *A Method of preventing the Attacks of the Asparagus Fly.*
By M. KERLL.

(Translated from the German, for the *Gardener's Magazine*, by J. L.)

IN the *Transactions* of the Prussian Horticultural Society (vol. ii. p. 396.) there is a notice of the asparagus fly (*Tephritis asparagi*), that scourge of the asparagus bed, in which it is stated as follows:—"An effective method has never yet been discovered for the destruction of the devastating larvæ of this

fly. The only one yet in practice is to cut off all the shoots of the asparagus to the end of May; but where, on account of seed-beds and newly formed beds, this method cannot be employed, the asparagus must be left to its fate."

After having struggled in vain, for the space of eight years, against the attacks of this fly, and having also applied all sorts of offensively smelling substances with a view to the destruction of the insect, but without success, the thought struck me, that I might, perhaps, sooner attain the end in view, by operating on the insect's sense of sight. For this purpose I set apart a bed of asparagus, which had been sown five years, the two last of which it had suffered severely from the fly. In the beginning of April I stuck in the pine branches close together (which, in winter, had been used as a covering) all along both sides of the rows of asparagus. Their points met close together over the plants, at a height of from 28 in. to 36 in., and formed a thick dark foliage. I had at first but little confidence in the attempt, because I was afraid of finding, as might be supposed, an immense number of the fly under the foliage; but in this I was mistaken. The fly, on the contrary, hastened from the dark shade to broad daylight, and, as long as the plants vegetated under the foliage, no shoots were attacked by it; but as soon as the tops penetrated through the covering to the open day, they became infested by the fly. If the shoot had already begun to branch out, only the twig that was attacked died; the others vegetated well, and no larvæ were found in the stems. It happened, also, that some shoots burst through the sides of the covering, the tops of which, when they had only just begun to branch out, were likewise immediately attacked by the fly, and suffered exceedingly. When I examined the passages of the larvæ, I found, to my great satisfaction, that, instead of extending as far down as the surface of the ground, they regularly terminated where the stem began to be woody.

When the asparagus, therefore, has attained the height of 12 or 18 inches, and the stem become woody, it will no longer suffer any material injury from the fly: at least, I found it so from my own experience; also, that seedlings suffer little from the fly the first year or two, as the shoots then consist of little else than cellular tissue.

The fly seems to dislike shade and moisture. I never could find any during wet weather, and when the sky was cloudy they were very seldom seen. It is, therefore, very possible, that the fly might be warded off by planting some kind of early-growing vegetables between the rows of asparagus, as a shade; such as artichokes or early peas. Unfortunately, I have no longer an opportunity of making more experiments, and, therefore, sincerely pe that others will do so, and communicate the results to the

public: and I have now only to add, with respect to the above-mentioned notice of this fly, that the search for it need not be limited, as there stated, to the month of May, as I have continually found it throughout the month of June; and in the preceding year it continued to be very numerous and destructive to the middle of July. I did not find that it lays its eggs in the earth, as stated in the above notice, but on the shoots of the plant itself, on which they may be distinctly seen; and the wound on the shoot effected by the ovipositor causes it to die completely off.

ART. VI. *An Account of the Tea Plantation of Henry Veitch, Esq., in the Island of Madeira.* Communicated by Mr. VEITCH.

DR. LIPPOLD, as you requested, has visited my plantation of tea, and will, I conceive, report to you that he never saw a plantation of any kind in a more thriving condition. The plants are both beautiful and luxuriant, and he saw them covered with flowers, and with the ripe seeds not yet fallen and new ones formed. He took samples of all, which he will, no doubt, preserve with his usual ability, and forward them to you. I have four different qualities of plants: the green, the black or bohea, the gunpowder, and the sasanqua; but I have not been able to prepare tea from the last. The leaf is too fleshy and brittle, and I have not succeeded in destroying its herbaceous taste, by any process that I have as yet tried. Of the other kinds, the green tea is the most robust; some of the old plants being from 7 ft. to 8 ft. high, and from 4 yards to 5 yards in circumference. The black is next in height, but it has scarcely half the spread of the former; while the gunpowder is by far the smallest, only growing from 4 ft. to 5 ft. high, and its leaves are not half the size of the others. The sasanqua is a very wide-spreading plant, but its branches are unable to support themselves, and might be trained along walls to a great extent; it has handsome double white flowers, while those of the other kinds have single flowers.

The plantation is situated at my country residence in the mountains of this island, called the *Jardin da Serra*, or garden of the hills, in a sheltered valley, about 3000 ft. above the level of the sea, where snow sometimes falls, but lies for a very short time, and where there are frequent hoar or white frosts, but never ice. It is considerably above the cultivated vine-grounds, and where grapes will not grow; though the luxuriance of geraniums, fuchsias, hydrangeas, and many other green-house, and even some tropical plants, is surprising. The plantations are on terraces, on the side of a hill; and the edges of the walls have hedges of gooseberries and currants. This proves that the tea plants are

of a much hardier growth than has hitherto been conceived; and they even succeed as an underwood, for some of the plants which are placed under the shade of chestnut trees are quite as healthy as the others.

The green-tea plant produces abundance of seeds, but the bohea flowers later, and its seed does not, consequently, set so well; the gunpowder, however, gives flowers almost all the year round, and is seldom to be seen without flowers and seeds in all their stages of ripeness; the sasanqua, from its double flowers, rarely produces seed.

My plantation was begun in 1827, and I received the few plants, viz. 16 in number, with which I commenced it, partly from Messrs. Loddiges of Hackney, and partly from China direct. I have now about 500 full-grown plants, and about as many more ready to plant out, with the means of multiplying them by seed and layers to any extent; but, unless I can succeed better in the manufacture of the leaves, and at far less expense than I do at present, it will never turn out a profitable speculation to me, though it may likely prove an advantageous one in future for the island, when practice and experience may have produced greater expertness, and furnished a more perfect knowledge of the preparation; for though I can make excellent tea by merely drying the leaves, yet to roll them up is both so tedious and difficult, without the destruction of at least two thirds of the quantity, by being broken and reduced nearly to dust, that it costs me more than the price of a pound of tea to prepare one, reckoning the leaves worth nothing. It is evident, therefore, that though I have obtained almost every information that books can teach me on the subject of preparation, much real information and practical knowledge are still wanting.

As I have proved that the tea plant is exactly suited to the climate of the mountains of this island, and is a much hardier plant than has hitherto been imagined (so much so, indeed, that it will not succeed in my garden in Funchal), I should be glad if, through your Magazine, I could obtain information from any person who has seen the thorough process of drying in China, for no other information could be of the least use to me; being convinced, notwithstanding the variety or different species of plants, that it is the mode of manufacture that produces the different qualities of tea that come to our market, and that, consequently, all kinds might be produced from the same plant, notwithstanding that in different districts (as in the case of cheese in England) are produced peculiar qualities. I have little doubt, however, that if I had hitherto had leisure to give more attention to the preparation, I should ere this have arrived at greater perfection in rolling up the leaves; for it is only since my retirement from my official duties of Her Majesty's agent and consul-

general at this place, that I have been able to devote my personal attention to this object. I shall be glad to afford you any farther information that you may wish on the subject.

Madeira, Nov. 26. 1839.

WE received from Dr. Lippold the specimens alluded to, which are of most extraordinary vigour. With respect to manufacturing the tea, Mr. Veitch is doubtless acquainted with Mr. Bruce's *Remarks on the Manufacture of Tea, and on the Tea Plantations in Assam*, which he will find, accompanied with an original map of the tea district, in Jameson's *Journal* for January, 1840, p. 126. — *Cond.*

ART. VII. *On Emigration, with reference to Gardeners; and on the Prospects of Botanical Collectors.* By PERITUS. Communicated by K. B. D.

I DON'T think I would have troubled you so soon again, had it not been for your asking my opinion as to your emigrating? I should decidedly say no. There may certainly be some difference between your plans and those of others who have gone out in search of plants, and thereby to make a livelihood; but still, the uniform want of success, hitherto, ought to make any one very cautious, and calls for much careful consideration ere such a step is taken. Take poor Drummond's case: he went out under most auspicious circumstances, and was well patronised; and his plants, both living and dried, were eagerly bought up; and yet he was unable to realise even his very moderate desire, to purchase and stock a few acres, and to settle with his family. Look also at Douglas: he barely got a living at the best, and was often in most distressing circumstances; and that, too, after sacrificing his health in search of plants. Others I might mention, but they all tell one melancholy tale. And as to patronage, what is it? Parties die, fashions (for there is a fashion even in flower-growing) alter, and tastes vary; and then, when, perhaps, you have embarked all your energies in the work, thrown up all your prospects for its sake, you discover your mistake. Nay, tell me, if you can, of one instance which has been successful. Perhaps you may cite Australia as a place where a gardener might do well. He is, perhaps, in receipt of large wages, or may *apparently* be doing well; and yet look at the heavy prices he has to pay for the necessaries of life. Besides, the states of Central America are the most unsettled of all the portions into which Spanish America was split; and, unless by your influence over a number of individuals, you can hardly

consider your life safe, and must join either one side or other in the horrible intestine war which continually rages there. Not only these things compel me to dissuade you from emigrating, but I think, with your talents, you may look forward to doing much better in England. There are curatorships of botanic gardens now and then vacant* ; nursery establishments either to be disposed of, or opened with every prospect of success : and I would advise you to look to these rather than emigration. However, I can only judge from report, and there are many who can form an opinion much better than myself, and who, no doubt, will gladly give you their advice. Tweedie was an old man when he went to Buenos Ayres ; he depends upon the profits of a store which his family attend to for his support, and not his plants. Matthews and Bridges both, I believe, had other sources of income than the plants and animals, &c., they sent over. Cuming is the only one of collectors that has made any thing, and that was by his shells and corallines.† How his trip to the Philippines may turn out, I don't yet hear. — makes little but what barely keeps him ; indeed, a gentleman wrote me, only a short time ago, that it would require every exertion to enable him to continue his researches since the death of the Duke of Bedford, who subscribed largely to his mission. You ask what he is doing ? Little, I fear, in the way of plants : there was a collection of seeds and some plants received from him a few weeks ago, and something is expected shortly. Apropos to emigration, I have sent to a relative for a copy of a letter on the subject of emigration to Australia, written by a friend who had been many years in India, and who was desirous of investing his large capital in that “land of promise,” which contains some good remarks on the fine stories we read of the settlers there ; and, if I receive it, I shall enclose it to you : at any rate, I must write to you again in a day or two, when you shall have it.

Feb. 5. 1840.

* A propagator who could furnish the councils or committees of such gardens, the London and Caledonian Horticultural Gardens included, with the lowest estimate at which common plants could be propagated and brought to market, would have a better chance of a curatorship than a skilful or scientific gardener.—*K. B. D.*

† Mr. Cuming had his first ideas of gathering plants from Mr. Anderson, during Captain King's voyage. Anderson went out one day looking after plants, and met Cuming among the rocks at Conception, looking for shells, &c. They were strangers to each other, but felt the greatest delight, when they found they were from the same country, and almost on the same pursuit, on this savage and inhospitable coast. Ever since this circumstance, they look on each other as two brothers ; and Cuming learned from Anderson how to dry plants, and the other duties of a collector.—*K. B. D.*

ART. VIII. *Description of a Glass Case for growing Plants in Rooms.*
By Sir JOHN ROBISON, Sec. R.S.E.

I HAVE been getting up a plant case of the kind described in the *Gardener's Magazine* for 1839 (p. 481.), in which I think I have introduced some essential improvements: 1st, instead of an expensive brass frame for small panes of crown glass, I have substituted four sides and a flat top of plate glass, which, requiring only corner astragals and a top frame of wood, is cheaper than the other, and greatly better looking. The sketch *fig. 15.* will serve to give you some idea of it. The principal innovation is, in providing for the perfect isolation of the air within the case from commixture with the air of the apartment it may be placed in. It appearing to me that the contraction of bulk consequent on re-

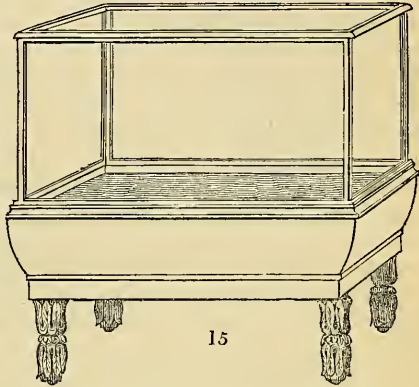

duction of temperature during the night, must necessarily cause an introduction of air from the apartment at a time when it was most likely to be contaminated with sulphuretted hydrogen from the gas lights and other causes, I have introduced a small tube through the bottom of the case, passing upwards to the surface of the soil. On the exterior end of this tube there is a coupling screw, by means of which I connect it with a flat bag of McIntosh cloth hung under the case, half-full of good air at the time of its attachment: the alterations of bulk consequent on changes of temperature, therefore, are provided for by the dilatation or shrinking of the bag, and no pressure is ever exerted to pass air through the joints of the case. Unless, therefore, the plants themselves cause a *permanent* change in the constitution of the air (which some of the best-conducted experiments seem to render improbable), it will remain unvitiated, and be subjected to those compensating changes only which the plants appear to make in light and darkness.

I do not mean to fill the case with permanent plants until May next, and in the mean time shall make use of it to flower hyacinths, &c. If you have attended to the subject of Mr. Ward's system, and should choose to suggest any experiments which the condition of this case may render practicable, I shall be happy to undertake them for you on your explaining your wishes.

Dec. 28. I have filled the case for three quarters of its depth with soil, have set on it several hundred bulbs (from snowdrops up to hyacinths, &c.), and have filled all the interstices between the bulbs with green moss. I have given only two gallons of water (Mr. Ellis's appeared to me rather moist), and have closed all up: some time must elapse before any judgement can be formed from the appearance of the vegetation; but already the circulation of the water is beautifully shown by the condensation on the glass plates, and the trickling down of the miniature rain. In the morning the glass plate which is nearest to and parallel with the window-sash, and which has consequently been losing most heat, exhibits both the condensation and running down of the water in a remarkable degree; while the inner plate, receiving heat from the air of the room, or by radiation from the objects near it, remains quite clear. I have planted a few bulbs in another receptacle (and in the same way as to soil and moss), by keeping which in the same room, but exposed to the air in the usual way, some judgment may be formed of the relative advantages of these different modes of raising such plants.

In the sketches (*figs. 15. to 18.*) I have not represented the outlets for superfluous water which are much in the same way as Mr.

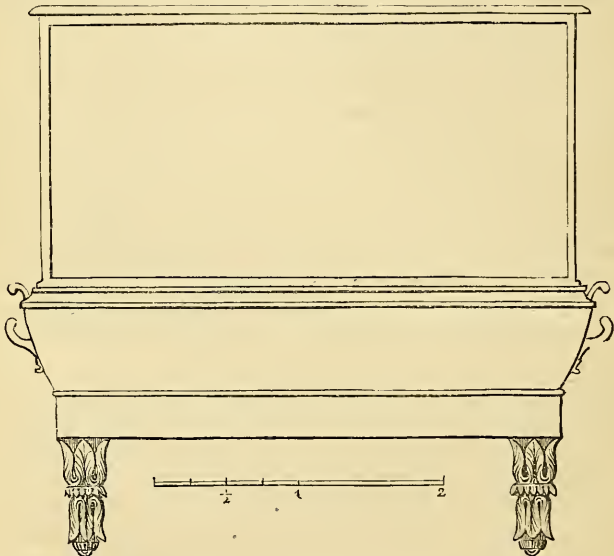

Ellis's above referred to. Neither have I shown the contrivance for maintaining the identity of the air first enclosed in the case; it would have confused the drawing, and will be easily understood from description. The size of the plates of the sides and top of

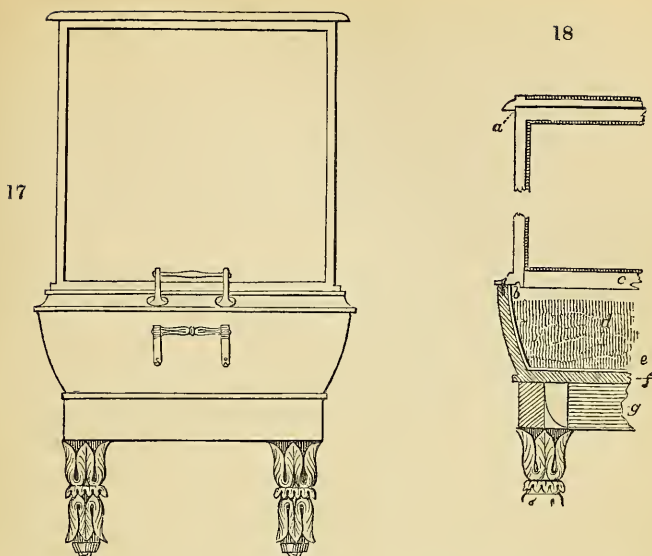

figs. 17, 18. is 3 ft. $7\frac{1}{2}$ in. by $22\frac{1}{4}$ in. A piece of tinned brass tube, a quarter of an inch in diameter, and a foot long, is passed through the bottom of the soil trough at one corner, and soldered to the lead lining. The part of the tube within the trough rises perpendicularly, and ends a little above the level of the surface of the soil. The shorter portion, which is without the bottom of the trough, is turned horizontally, and terminates in a brass connecting screw, to which a corresponding screw of a small stopcock is attached; to this stopcock a second stopcock, previously inserted in the end or corner of a M'Intosh air-pillow, is to be screwed on. This air-bag should be of such dimensions that it may be concealed within the frame on which the soil trough stands, in the hollow of which it may be supported by tapes or strings passed from side to side under the bag. At the time the bag is attached to the stopcock on the brass tube, the temperature of the air in the conservatory should be observed, and if it be at or near its maximum of elevation (and the air consequently near its maximum of dilatation), the bag should be nearly full of air; and *vice versa*, if the temperature be low, the bag should be very flaccid when attached, in order that it may have capacity to receive the air expelled from the case when dilatation takes place on the temperature being raised. By this means the air contained within the case and bag, though constantly changing place, will never communicate with the external air, and its identity will be maintained with considerable exactness.

The double stopcock will afford the means of occasional separation of the bag, and of examination of the contained air under the influence of different circumstances.

In the section *fig. 18. a* shows the check or rebate in the top, which lifts up, and is faced with wash-leather; *b*, the drip for the condensed moisture from the glass; *c*, the glass frame screwed down on the soil box, with a slip of wash-leather between them; *d*, the soil in the box; *e*, the lining of lead, with an inner lining of thin wood; *f*, the bottom of the soil box; and *g*, the frame on which the whole rests.

As before observed, I planted the case with some hundreds of bulbs of various sorts on December 28.; and, at the same time placed some of the same bulbs in earth in garden pots, and others in water glasses. Those in the case are distinctly gaining on those in the pots and glasses, and will flower before them. The case stands in a window, facing a little to the eastward of south, and gets what sunshine the season affords. There is no fire in the room, and the temperature near the window rarely exceeds 60° ; the pots and glasses are in a window looking N.N.W., but have the advantage of from 2° to 3° of higher temperature during the day; in the night time the whole house is nearly uniform, at from 57° to 60° [being heated by one of Silvester's cockles, as will be described in our *Supplement to the Encyclopædia of Cottage Architecture*].

I have heard lately of some curious cases of the roots of plants running to a distance in search of bones, and then insinuating themselves into every crevice within them. I recollect also observing at Malmaison that many plants which had been inserted in skulls of animals, were flourishing in a remarkable manner. This leads me to ask you whether bones and bone-dust have been much tried in horticulture, and whether you would counsel me to try some in the case, when in May next it is prepared for its permanent inhabitants. [We shall be glad of a hint on this subject, or on any other relative to this article, from any correspondent.]

Edinburgh, Randolph Crescent, Jan. 20. 1840.

ART. IX. *Some Account of a Mode of warming and ventilating Hot-houses invented and applied by John Penn, Esq., Engineer, &c., at his Residence at Lewisham, in Kent.* By the CONDUCTOR.

THE first attempt that was made to heat hot-houses by hot air was, we believe, made by Dr. Anderson, in a green-house attached to his dwelling-house at Isleworth, about 1802, as described in his *Description of a Patent Hot-house*, published in

1803. The next was by Mr. Stewart, in the large conservatory at Mr. Angerstein's at Blackheath Park, about 1803, for which a patent was taken out by Mr. Stewart. Both these houses we saw in 1803. Neither of these modes of heating by hot air was considered at the time as completely successful: in one case, we believe, because the air was heated by smoke flues, and consequently was too dry; and in the other, on account both of the means (the heat of the sun) and the arrangements being inadequate. Some time afterwards, but at what period we are uncertain, the Messrs. Strutt of Derby applied their cockle to heating hot-houses by a current of air brought from without, with a power of stopping the supply from without, and reheating the air of the house. A vinery at St. Helen's, the seat of Edward Strutt, Esq., M. P., and one at Bridge Hill, Belper, the seat of George Strutt, Esq., continue to be so heated; and Jedediah Strutt, Esq., has recently heated several hot-houses by this mode, at his residence in the village of Belper, which, as observed in our volume for 1839, p. 448., appeared to answer perfectly, when we saw it in May last; an arrangement being made by which the heated air passes over water, and thus becoming charged with moisture, the defect attendant on all the preceding modes appeared to be remedied. The large conservatory at the Grange was heated by hot air from one of Mr. Strutt's cockles combined with steam, by the late Mr. Sylvester, in 1825, as noticed by us in our first volume, p. 112. Such is the amount of our present recollections on the subject of heating hot-houses by hot air.

Mr. Penn's mode of heating and ventilating by hot air differs from the above modes, in the heating body being pipes of hot water, and in the great simplicity of the arrangements. It appears to us to effect the object much more completely than by any other mode that we have seen; the great simplicity of the arrangements being such, that, as it appeared to us, no repairs can be required for a number of years to come, not, indeed, till the pipes are worn out. This constitutes its superiority to the mode of heating at Belper and the Grange, which appeared to us rather more intricate.

The section, *fig.* 19., will show Mr. Penn's mode of heating almost without explanation. The pipes of hot water which heat the air are shown at *a*; the opening by which the air enters the house, at *b*; *c* is a grating by which the air is drawn in again, and conveyed along the drain *d*, to be reheated by the pipes, and again rarefied so as to reenter at *b*. By these simple and obvious means, the air is in a state of continual circulation, as shown by the arrows in the section. The degree of heat in the house is regulated by shutting, partially or wholly, the openings (*b*) by covers which are fitted to each. The drains (*d*) are made at greater or less distances according to the heat required; and, when

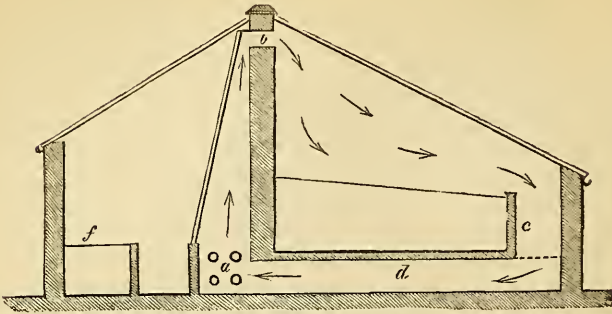

extra-moisture is wanted, water is poured through the grating (*c*), so as to cover the bottom of the drain. In Mr. Penn's hot-house, in which he grows orchidaceous plants, the drains are about 6 ft. apart, about 18 in. deep, and 1 ft. wide; in his green-house, they are about 12 ft. apart; and in his pine-pit, the pines being plunged in tan, they are about 7 ft. apart. In a span-roofed hot-house for botanic or stove plants, the hot-water pipes are ranged along the centre of the house; and the tubes in which the hot air ascends from the pipes are of boards, and fixed immediately over them, under the ridge of the roof, with their tops reaching to within 2 ft. of the glass. In the pine-stove, the hot-water pipes are under the back path, and the tubes, which are of boards about 18 in. broad, by 9 in. deep, are placed against the back wall in the inside of the house, each having a cover that takes off by the hand. In those houses that have back sheds, the tubes are in the outside of the back wall, as shown in *fig. 19.* at *c*. The shed has a double roof to retain the heat; and the border, shown at *f*, is used for forcing sea-kale, rhubarb, &c., and for raising small salading. Care is taken in forming the drains that they shall open to the pipes, not directly under the upright tubes, but in the space between them, as shown in *fig. 20.*, in which *g g* are the drains; *h*, the situation of the gratings over them; *i*, the situation of the tubes; and *k*, the hot-water pipes. The object of this arrangement is, to allow the air from the drains to pass a short distance along the hot-water pipes, so as to be reheated before it ascends to enter by the openings *b*. When it appears desirable to change the air of the house, this is not done by opening the sashes in the usual way, but by taking the stoppers out of two openings into the back drain which contains the hot-water pipes, one at each end, and communicating with the open air. These openings are so small, that each may be filled up with a brick, and made air-tight by a little clay. It ought to be observed, that the wooden tubes by which the hot air ascends are all made perfectly

20

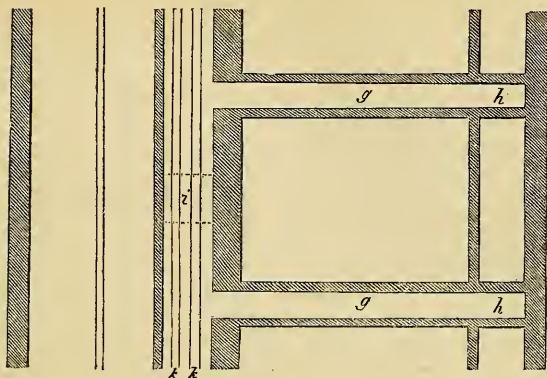

air-tight; those in the sheds, being of rough boards rudely joined, have the joints covered with strong paper pasted or glued on: if the openings were carried up in the wall, of course this case would not be requisite. This description and these diagrams have been made entirely from recollection of a visit made to Mr. Penn, in company with Mr. Wilmot of Isleworth, on February 5th, in which Mr. Penn kindly showed and explained everything; and therefore they must not be considered as exact, but merely as giving a general idea of what has been effected.

Though Mr. Penn only began his improvements not quite three years ago, and has not yet completed all his experiments, he has already heated several hot-houses for different noblemen and gentlemen by his mode; and some, such as one at Syon House, have been heated after Mr. Penn's mode (though imperfectly), by others who have seen or heard of it, and endeavoured to possess themselves of the invention, without understanding it. Houses have been heated by Mr. Penn, for the Earl of Clare, in Ireland; the Earl of Dartmouth, Blackheath; Charles Perkins, Esq., Southend, Kent; — Palmer, Esq., Bromley; — Keats, Esq., Forest Hill; General Sir More Disney, Acton; Charles B. Curtis, Esq., Acton; John Wilmot, Esq., Isleworth, and others. He has also warmed the dwelling-house of B. Wood, Esq., M. P., Eltham Place; and that of — Crowley, Esq., Croydon; as well as his own billiard-room, at Lewisham. All Mr. Penn's plant-houses at Lewisham, as well as his billiard-room, though scattered up and down his garden, are heated from one small boiler.

It may be useful to state that Mr. Penn, being an engineer, and in a very large way of business as a manufacturer of steam-engines, and all sorts of machinery, and having large iron-works, being a man of large property, and being, besides, most anxious

and enthusiastic for the propagation of his plan, will carry it into execution in any part of the United Kingdom at less cost, and, as being the inventor, more successfully, than is likely to be done by any other person whatever.

We shall now state what we consider to be the principal advantages of Mr. Penn's improvement.

1. The heat of air in motion, whether dry or charged with moisture, is never felt by the human body to be so hot or oppressive as when it is stagnant. This every one will recollect to be the case, when he thinks of what were his feelings during a hot summer's day, when there was no breeze, and when there was a breeze. We could not have believed that the difference would have been so great in a hot-house, had we not experienced it. We remained in Mr. Penn's orchidaceous house about half an hour, with the temperature about 80° , and in his pine-pit about the same time, without feeling the slightest inconvenience; so much so, that we could have passed the day, with pleasure, in such a temperature. We felt as if we were in the open air, in a fine summer's day, and experienced none of the disagreeable effects of stagnant and sometimes fetid air, which are so often experienced in hot-houses, particularly in those in which the *Orchidaceæ* are grown. The same thing, Mr. Penn observed, had been noticed by a number of persons, including ladies, who stated that they could never remain more than a few minutes in their stoves at home, while they could have remained all day, and even slept, in Mr. Penn's. An analogous effect was experienced at the North Pole, by Captain Parry and his companions: when the air was perfectly still, the extreme cold of that region was bearable; but the moment the slightest breeze arose, it became intolerable. We had no means of trying the moisture of the air by a hygrometer, but that the moisture must have been considerable, was evident from the water in the drains, and the dew on the plants.

This alteration in the sensible effect produced by hot moist air on the human frame, we consider to be the great advantage of Mr. Penn's improvement, because it will henceforth render plant stoves of every kind, including even orchidaceous houses, fit for being entered into, and even lingered in, by the most delicate, as well as the most robust, constitutions.

2. By the circulation of the air, blossoms of every kind will be made to set better, fruit will be produced of higher flavour, and leaves and blossoms of more intense colour. We had a proof of these results. In one house there were strawberry plants in pots just going out of flower, and Mr. Wilmot, who was present, declared that the fruit was as well set as if the plants had been in the open air, though the sashes of the house had not been opened, nor any fresh air admitted but what entered through

the laps of the glass or by the occasional opening of the door, since the strawberry plants were introduced. Some queen pines had ripe fruit, and one of them being cut and tasted, Mr. Wilmot pronounced it to be far superior in flavour to any queen pine that he had ever tasted at this season of the year. See Mr. Wilmot's letter, which forms the succeeding article.

3. A great saving of heat in the case of forcing all trees or plants which can be trained on walls or trellises, and in the case of ornamental stove trees or shrubs that can be so trained. The manner in which this can be effected is, by planting the trees against a perpendicular wall or trellis, or against a wall or trellis with any required degree of slope, and covering the wall or trellis with glass; the border having a vacuity underneath it, so as completely to isolate the roots, and admit, by the general arrangement already described, of a constant circulation of warm moist air between the glass and the wall, between the upper surface of the border and whatever covering may be placed over it, and underneath the border. In consequence of this arrangement, a very small volume of air requires to be heated, while the circulation of the air is more certain of passing through among the leaves, blossoms, and fruit. The border where this system is adopted may either be covered with a boarded roof at the distance of 1 or 2 feet from the soil, or with glass sashes at the same distance; and, in the latter case, the surface of the border may be used as the surface of a hot-bed, and pots of strawberries or other plants set on it to be forced, or sown or planted in it to be grown. The only disadvantage attending this arrangement is, that the trees trained against the wall can only be examined by persons outside the glass, and, consequently, that when they are to be watered or pruned the glass must be removed. Even in large houses or pits, where pots of strawberries or kidneybeans are placed immediately under the glass, only a stratum of 1 or 2 feet in depth will require to be heated; and, by arrangements, that object can easily be effected. For example, a temporary flooring of boards under the plants trained, or under the pots of strawberries or kidneybeans, with the joints made airtight by strips of paper or canvass glued on, would be sufficient. In some cases, a bed of earth, which might serve as the border for roots of vines or peaches, would render this temporary flooring of boards unnecessary.

4. All the plants, including cucumbers, which were in fruit, and some shrubs which were in flower, were in remarkably vigorous health; so that the circulation of the air, independently of all other circumstances, seems to produce a positive benefit to the plants. The blossoms of the Persian lilac, when forcing, are generally without fragrance, but Mr. Wilmot and ourselves found that this was not the case here. In short, as Mr. Wilmot

observes in his letter, all forcing will henceforth be a farce where Mr. Penn's mode of heating and ventilating is not adopted.

5. Mr. Penn's improvement can be added to any house or pit already existing, whatever may be its form or dimensions; though, of course, with more advantage in the case of some forms than others. Mr. Penn also informs us that a house that has been already heated by hot water or steam can be rearranged according to his plan, and the same boiler and pipes used.

6. In the atmosphere of London, where the air is charged with soot and smoke, Mr. Penn's improvement will admit of forming a green-house or stove with much purer air than could be obtained by admitting the external atmosphere according to the usual means of ventilation, which would not only be better for the plants, but for persons going in to examine them.

Of course such an improvement as Mr. Penn's, which has only been made about three years, admits of an endless variety of modifications. For example, all the shutters to the tubes might be regulated by a self-acting apparatus, so as without personal attention to keep the house constantly at any required temperature. A long cylindrical tin tube, air-tight, placed horizontally against the back wall, with an accurately fitted piston, might be the moving power; or a thermometer on Kewley's principle, with a cylinder and piston acted on by water supplied from a cask on the top of the wall of the house, as exemplified in 1819 in Colvill's Nursery, King's Road, and described in our *Encyclopædia of Gardening*, edit. 1835, p. 558. By means of such an apparatus, the forcing might go on for days together without any attention from the gardener, provided fuel and water were supplied to the boiler; and by a self-supplying hopper, and the use of coke or anthracite coal, the fire would not require attention more than once or twice a day. By a very simple arrangement of the piston of the tin cylinder, or by Kewley's regulating thermometer to operate on a piston to be raised by water, a damper might be opened or shut, so as in some degree to regulate even the fire. In this way a gentleman or lady, with the assistance of a house servant, might be in a great measure their own gardener. The common fruit-wall of a garden might have upright sashes placed in front of peach trees or vines, the hot-water pipes placed behind, and the hot air brought up as shown in *fig. 21*. Then, if the border were supported on flagstone, like that of Mr. Jedediah Strutt at Belper (see our volume for 1839, p. 448.), the whole mass of soil and roots might be heated as completely as if they were in a pot. The border might be covered with horizontal glass, with the exception of a part close under the upright glass, to be boarded as a path; and under the horizontal glass, pots of strawberries might be placed, early potatoes planted, or cucumbers and other dwarf or spreading articles

grown. In *fig. 21.* *a* is the front glass, nearly upright, and consequently well adapted for winter forcing, when the sun is low, and will strike it nearly at a right angle; *b* is the path of boards under which sea-kale, chic-cory roots, &c., in pots might be forced; *c*, the horizontal glass over the border; and *d*, the gratings to the drains.

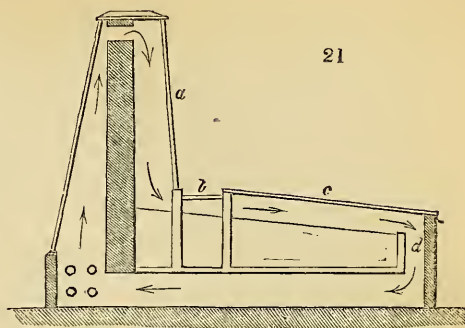

The direction of the current of air is shown by the arrows. *Fig. 22.*

shows part of the ground plan, in which *ee* are the drains, *ff* the situation of the gratings, *g* the hot-water pipes, and *h* the air-tube. A thermometer, and a hygrometer acting by gravity, might be hung inside the front glass, and inspected by walking along the boarded path. When pruning or watering was required, the warmest moments of a fine day should

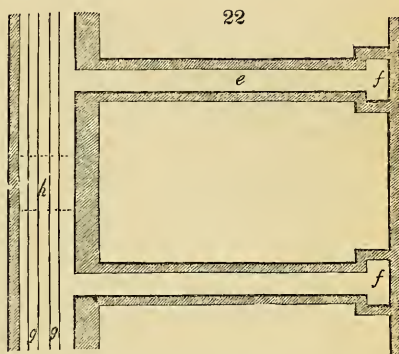

be chosen, and the sashes opened one by one for a few minutes. Fumigation by tobacco might be performed when necessary, by burning the tobacco over the hot-water pipes; and it is almost unnecessary to observe that the atmospheric moisture might be increased to any desirable extent, by throwing down water among these pipes, so as to cover the bottom of the drains.

To prove the rapidity of the circulation, it is only necessary to throw a piece of burning paper among the pipes, or a little rose water or fragrant oil over them, when in a few seconds the smoke or the fragrance will be perceived over the front path. To make this construction and arrangement economical, shutters of boards, or of hurdles covered with bark, reeds, or straw, should be adopted both for the front and horizontal glass.

About the end of the last century, an attempt was made in the neighbourhood of Bristol by Dr. Pritchard and others, and revived again by a Lincolnshire gentleman, to enclose a large space, cover it with glass, and heat the interior to the temperature of Madeira, as a substitute for that climate to invalids: the plan did

not succeed, for want, among other causes, of efficient ventilation, combined with adequate heat; but by Mr. Penn's plan all difficulty on that point will be readily overcome. Suppose, however, that the plan had no other advantages than that of rendering the air of orchidaceous houses and stoves agreeable to the feelings, instead of being oppressive and unbearable; that result alone would be sufficient to constitute it one of the greatest improvements that have hitherto been made in the production of artificial climates for plants.

In conclusion, we have only strongly to recommend all such persons as may be disposed to try Mr. Penn's plan, to apply to Mr. Penn himself; not only because he must necessarily understand his own plan better than any other person, but that, being an independent man, and most eager for the celebrity attendant on the dissemination of his plan, he is most likely to carry it into execution cheaper than any other tradesman can do. Indeed, Mr. Penn authorises us to state that he will carry his plan into execution any where in the United Kingdom; and, after a year's trial, if it should not give entire satisfaction, he will take the apparatus back again, and replace whatever apparatus may have been there before, entirely at his own expense. We are the more particular in stating this, because, from the circumstance of Mr. Penn's not having taken out a patent, and the invention being likely to come into universal use, there will, as in the case of Arnott's stoves, be numbers of imitators, and pretenders to improvements, who do not understand even the first principles on which the arrangement acts. With the most noble and disinterested views, and apparently, also, with views the most judicious with reference to the public good, Dr. Arnott left his improvement open to the competition of every ironmonger; in consequence of which, every ironmonger constructed Dr. Arnott's stoves, and by far the greater number of them spoiled them. It would have been much better for the public had the doctor taken out a patent. We wish Mr. Penn had done so; but, since he has not, we consider it our duty most strongly to warn the public against employing others to execute the plan of an inventor, when they can get it executed by the inventor himself, and that with the advantages above stated. We have only to add that Mr. Penn undertakes to construct all kinds of hot-houses, whether of timber, or of iron or other metal. — *Bayswater, Feb. 8. 1840.*

ART. X. *Mr. Wilmot's Opinion of Mr. Penn's Mode of heating and ventilating Hot-houses.* Communicated by Mr. WILMOT, F.H.S., &c.

As you have written to me on the subject of Mr. Penn's principle in heating hot-houses, pits, &c., and expressed a wish for my opinion thereon, I will endeavour to convey it in a few words.

About the middle of April last, Mr. Penn had twenty large pine plants from out of my houses, a number of which were queens; and it is universally acknowledged that at this season of the year the queen pine is of little value, in size, appearance, or flavour, rarely seen to swell the pips prominently, or to come of a good colour. The result of Mr. Penn's principle, in this instance, has fully confirmed my opinion that forcing *is a farce* without it. My pines, in the same pit from which Mr. Penn had his plants in April last, are now ripening, and some cut, swelled, as they usually are, to about a pound and a half each, and with a flavour little better than a Swedish turnip. Those at Mr. Penn's (one of which you and I partook of yesterday) possessed every property of a queen pine. It was well swelled, of a most beautiful colour; and its flavour was equal to any queen pine ripened in August. Mr. Penn's pretensions to horticulture are certainly very limited. He knows but little about forcing; the gardener that grew the plants, less. Such being the case, it can only be the system which has produced such an effect on the size and flavour of the pine. This system, I am happy to say, has far exceeded my most sanguine expectation, and as it must be seen, fully to appreciate its value, I shall be happy to exhibit it in action to the horticultural world about April next, when I shall invite all friends to horticulture to see it at work in my extensive forcing establishment. — *Isleworth, Feb. 6. 1840.*

P.S. The man that grew the pine plants having lately left Mr. Penn, I cannot accuse his present gardener of want of ability.

ART. XI. *On the Conical Boiler for heating Hot-houses by hot Water.*
By D. BEATON.

IF the reader will turn to the 13th volume of this Magazine, at page 298., he will find drawings and descriptions of the original conical boiler, which was invented in 1835, at New York, in the United States, by a lad only 18 years of age. This useful invention, which is destined to make an entire revolution in the system of heating by hot water, created little interest at that time in Britain, and might have passed down the current of oblivion like the mere bubble of a season, had it not been for the ingenuity and perseverance of J. Rogers, Esq., F.H.S., Vine Cottage, Sevenoaks, Kent. Under this gentleman's directions it was greatly improved by Mr. Shewin, ironmonger, of the same place. The credit of bringing this boiler prominently before the British public is therefore due to Mr. Rogers.* He presented

* Since Mr. Beaton sent us this article he has supplied us with the following note. "I have since learned that, as far as Mr. Rogers is concerned, it

one of these boilers to the council of the Horticultural Society, and its merits were satisfactorily proved in the Society's Garden, and made known to the fellows, and ultimately to the public at large, through the *Gardener's Gazette*, *Gardener's Magazine*, Paxton's *Magazine of Botany*, and other periodicals, all of which overlooked the original inventor so far as to allow him no share of the merit of this very useful invention.

The boiler is yet susceptible of improvement. In its present form it is made up of two concentric cones, joined at top and bottom by flanges sufficiently wide to leave a space of one or two inches between them for the water. The fire is applied in the inner cone. There is a defect in the outset, which is soon detected in practice. As soon as the fire begins to burn clear in the inner cone, the heat is generated faster than the small body of water can absorb it, and steam is soon produced. There is a small pipe fixed in the top of the boiler with a steam valve to guard against accidents. By close attention to the fuel and damper, this steam might be avoided, and only as much heat produced as could be absorbed by the water; but this requires too great a nicety for so simple an apparatus. Instead of having the inner part of the boiler a cone, let us have it more of a cylindrical form: this would reduce the size of the fire and the surface to be heated, and it would increase the space for the water in the same ratio. Probably some modification of this kind would simplify the working of the boiler by producing no more heat than is absorbed by the water. At any rate, we must get rid of the steam, at least till the water in all the pipes is heated to 200°.

It were desirable that those who use this boiler, and think they could suggest any improvements, would convey their ideas to Mr. Shewin, as above, or to some other enterprising iron-monger or engineer, in order that we may have the benefit of this most excellent invention to the fullest extent. The very great saving in fuel, the almost entire absence of smoke, and the ease with which it can be attended, will cause it to supersede all other forms of boilers now in use; and there is no reason why it should not be made sufficiently large to suit houses of any size. An article, like this boiler, which must soon come into universal use, will, no doubt, be taken up by several tradesmen for the sake of profit, and several modifications of it in consequence

was an invention to which Mr. Rogers was led by a series of experiments founded on certain principles, and having a certain object in view. Mr. Rogers tried a vertical cylinder first, which did not answer perfectly, wasting much heat. He then employed a cone, which succeeded better. But for Mr. Shewin's perseverance in accomplishing the object in cast iron, it is doubtful whether it would ever have become of general service; as Mr. Rogers's original boiler was made of copper, which was much more expensive, and, as it proved, much less durable, than iron. — *D. B.*"

will soon be before the public ; it is therefore but justice that Mr. Hogg, the original inventor, should have his share of the merit.

I suggested to Mr. Shewin this week to make small boilers, or rather steamers, on this principle, for steaming houses and frames in summer, when no fires are at work, and for smoking houses or frames by the steam of tobacco liquor ; or by a decoction of common tobacco leaves. This is a novel plan for destroying insects, but I am fully satisfied it would answer better than the present mode of smoking. The vapour would condense and fall down on the plants in the form of dew, whereas smoke soon finds its way out at every crevice. Many other decoctions or solutions might be tried in this way, for the destruction of scale, bug, or even wood-lice, when something effectual for the destruction of these creatures might be found out, and on which the operative chemist might try his ingenuity. I saw a vessel in shape between a tea-kettle and watering-pot used for steaming houses twenty years ago. Many other contrivances for the same purpose have been tried since, and found to be very beneficial ; that by Mr. Forest, at Syon Gardens, is very effectual ; but this by the conical boiler is the simplest and cheapest that can be used. A gentleman in this neighbourhood used a most elaborate and expensive machine for the same purpose last summer, and with perfect success. The conical boiler, for these purposes, should have the inner or furnace part in the form of a cylinder, from 6 in. to 10 in. wide, and from 10 in. to 14 in. high ; the outer part may either be a cylinder or cone, at pleasure ; the top should screw on, and have a short pipe fixed in it for filling it, to which another pipe of the required length, and with a universal joint, should be fixed for conveying the steam into the house or frame, which might be done through a pane of glass in front, or in any other way more convenient. A movable sheet-iron box should be attached to the bottom to receive the ashes, and the whole might be mounted on a barrow similar to that of a small watering engine : such a boiler or steamer might be got for 40s. or 50s., and it would last two or three lifetimes if properly taken care of. What a nice plan for smoking or rather steaming cucumbers, melons, and heaths, which do not like smoke ! I hope Mr. Shewin will attend to these suggestions : every one having house-plants would soon possess one. It might even be taken to the peach wall ; and, by means of the universal joint, a stream of tobacco steam could easily be directed against all parts of the trees ; and the same way with standard roses, &c. By the same means a house could be filled with any sweet odours, to keep down any disagreeable smell from tan, dung, flues, &c. ; but I believe I have said enough in its praise to draw public attention to it.

Kingsbury Gardens, Jan. 1840.

ART. XII. *Description of the Conical Boiler and hot-water Apparatus invented by John Rogers, Jun., Esq., F.R.S.* Communicated by Mr. ROGERS.

I HAVE much pleasure in furnishing you with a description of my conical boiler, of which you are pleased to express so favourable an opinion. The apparatus, as at present constructed in cast iron, is the result of a series of experiments, which have engaged my attention at intervals during the last five years. My first attempts were made in 1835, with a cylindrical boiler of tinned iron, of which an account was published in Paxton's *Magazine of Botany*, for March, 1836. The experience thus attained led me to adopt a conical instead of a cylindrical furnace; and, in a paper published in the same work, in March, 1837, my boiler had assumed very nearly its present form. Various difficulties, however, arose in the construction of the apparatus. Copper, the material which I had employed in my second boiler, in the hope that it would prove durable, was corroded in a few months, by the sulphur disengaged from the coke; while the expense and difficulty of casting such peculiar forms in iron deterred me from employing that material, especially as it was a matter of considerable doubt whether its unequal expansion would not cause such a boiler to break, or become leaky. At length, after some other unsuccessful experiments which it is unnecessary to detail, the ingenuity and perseverance of Mr. Shewin, an ironmonger of this town, have succeeded in overcoming the difficulty of casting in iron, and a boiler has been produced which combines strength and solidity with the advantages previously attained. The only point in which the iron is inferior to copper is, that the greater thickness of the metal does not allow the heat to be transmitted from the fuel quite so rapidly. In practice, however, this is scarcely perceptible, and is far more than compensated by the superior strength, economy, and durability of the iron boilers. Indeed, I believe that those in copper could never have been made generally useful; for, besides their liability to wear out, on which experience a little varies, they were very easily injured by rough usage.

As many of your readers are probably unacquainted with the apparatus, I shall endeavour to give a description of it in its present form, with such plans and particulars as may enable them to judge how far it is applicable to their purposes, and, if necessary, to erect it themselves.

Fig. 23. is a front view of the boiler as at present constructed in cast iron. The interior, a sugarloaf-shaped cone (indicated by the dotted lines), being the furnace, which is filled with fuel through its upper orifice (*a*). A circular fire-grate is fixed just within the bottom of the boiler; and the aperture *b*, seen in

front is intended solely to remove clinkers which may form, or fuel when the fire is extinguished; at other times it is closed with a fire-brick plug, and should never be opened except when absolutely necessary. My original boiler had no such opening, and was fitted with a revolving grate, which overturned to empty the furnace; but various inconveniences, and the frequent breaking of the pivots on which the gratings swung, have led me, somewhat unwillingly, to adopt the present alternative.

For a side view of the boiler see *fig. 26.*, where it is represented as attached to a range of pipe. *f* and *r* are the flow and return pipes, and *d* a flange for examining and cleansing the boiler when necessary. Into this flange is fixed a small pipe, which, being connected upwards with the supply cistern *e*, and downwards with the cock or tap *h*, serves to fill and empty the apparatus. The supply cistern (*e*) acts also as an expansion cistern, to receive the volume of water increased by heat.

Fig. 24. shows the most convenient mode of setting the above, exhibited by a front view. A solid base being built with an

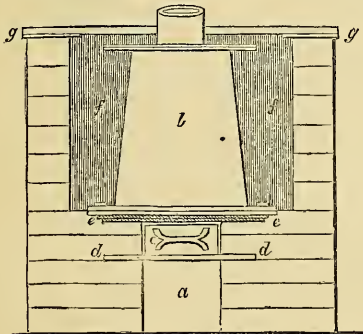
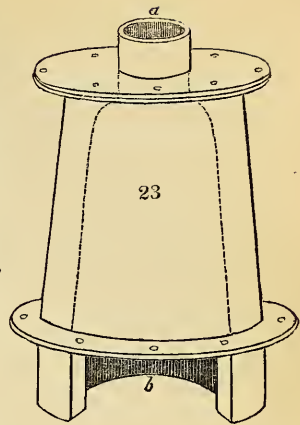

24



aperture in its centre open to the front, as high as the desired depth of the ash-pit, the boiler is fixed upon it, and the brick-work carried up to its lower flange or rim. The side walls should then be raised, in 4-inch work, level with the top of the boiler, as represented in *fig. 24.* *a* is the ash-pit; *b* the boiler; *c* the aperture in front of the boiler, closed with fire-brick; *ee* and *dd*

two bars, one supporting the fire-brick plug, and the other fitting to the rim of the boiler to support a slate which closes the front as in *fig. 24*. *ff* (*fig. 22*.) is the chamber around the boiler, filled with sawdust as a non-conductor of heat; and a layer of sawdust extends over the top of the boiler, under the slate slab *g g*, which is fitted over the brickwork, an aperture being cut in it to allow the throat of the furnace to pass through.

Fig. 25. gives the same view farther completed: the front of the chamber is closed with a slab of slate, and on the slab which covers the boiler is erected a chimney, having a feeding-door, through which fuel is supplied, placed in its sloping face directly over the mouth of the furnace. This chimney must not exceed 4 or 5 feet in height, and its area must in no case exceed the area of the mouth of the furnace. That here represented, viz. a brick base, with a piece of 4-inch iron pipe about 3 ft. in length, will probably be found most convenient, unless a movable chimney be preferred. This chimney should be fitted with a damper just below the iron part, to give greater command of the draught. The aperture of the boiler, which is closed with fire-brick, and the front of the ash-pit, should also be closed by a door or blower, having a regulator to admit or exclude draught. A blower is preferable to a door, as hinges are always liable to rust, and then break or strain; and it is important to be able to close the ash-pit pretty accurately.

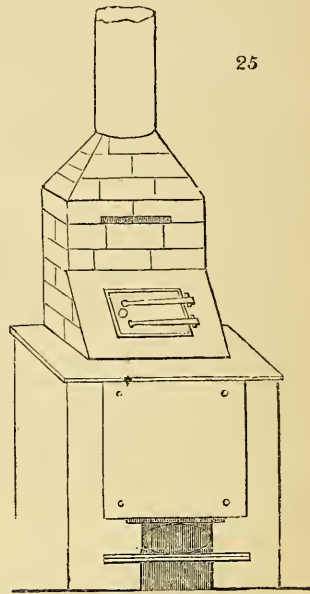
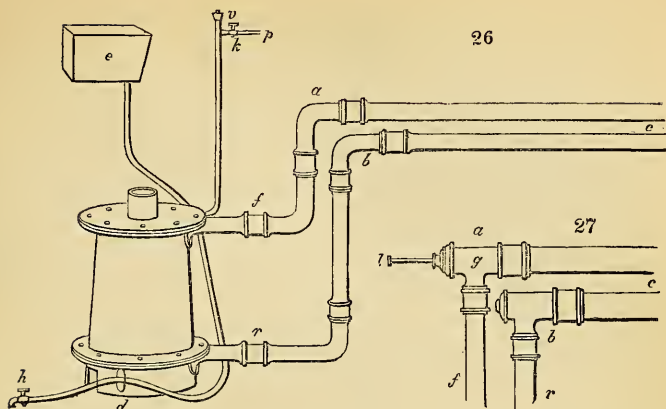

Fig. 26. shows the relative position of the boiler and pipes, and the mode of attaching and arranging them. In the first place, the whole of the pipes should, if possible, be above the boiler. One foot is sufficient, but when convenient, the higher the better. When 2- or 3-inch pipe is employed, the pipes may rise uniformly about 1 in. in 20 ft. from *a* and *b* to *c*; on which, being thus the highest point of the pipes, an air-cock is placed. But, if 4-inch pipes be employed, it is better that *a* should be the highest point, and the air-cock placed there; and that the pipes should fall uniformly 1 in. in 20 ft. from *a* to *c*, and from *c* to *b*: indeed this is generally the best arrangement, where not inconvenient. From *b* the return-pipe *r* should descend either perpendicularly, or with



as steep an inclination as possible, to the bottom of the boiler. The supply cistern (*e*) must be so placed that its bottom is not lower than the highest point of the pipes. The top of the steam-valve (*v*) should be level with the top of the supply cistern. Just below the valve, on the steam-pipe, may be fixed a small cock (*k*), connected with a pipe laid into the house, by which, whenever the water boils, the house may be steamed. In small apparatus this will happen pretty frequently, but in large houses, in order to insure this advantage, a stopcock or sluice should be placed on the flow-pipe (*f*), by which, the circulation being intercepted, the water in the boiler may at any time be raised to the boiling point in a few minutes.

Fig. 27. represents a contrivance which is not liable to any of the defects of stopcocks, which impedes the circulation less than any except large sluices, and which is comparatively unexpensive. The hollow plug *g* (*fig. 27.*) is fitted with a valve, perfectly watertight. This valve is opened and shut by the handle sliding through a stuffing-box in the end of the plug. By closing it the gardener may at any time cause the water in the boiler to boil, when, by opening the cock *k*, he admits as much steam to the house as may be desired. A small pewter pipe $\frac{3}{8}$ in. diameter is sufficiently large to conduct steam into the house, and its flexibility renders it very convenient. Where this arrangement is adopted, the supply cistern must be larger than is otherwise necessary, and should contain 10 or 12 gallons. The steam-pipe, also, should be placed on the top of the boiler, and be of sufficient diameter to allow the water and steam to separate, that the former may not be blown out through the pipe along with the steam; and the valve should be loaded with a few ounces of lead.

Fig. 28. exhibits the apparatus, with the addition of a reservoir; this in small pits is very desirable, and I have always

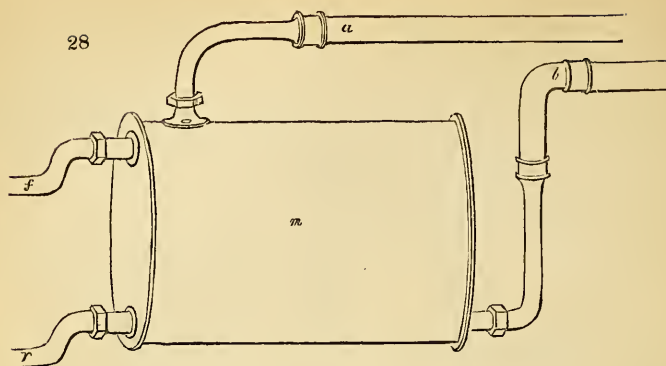

employed it in my own. The letters indicate the same objects as in *fig. 26.*, except *m* the reservoir, which may be formed of thin copper in the form of a cylinder, and should be packed in a wooden or brick case, in sand or sawdust, which supports its shape, protects it from accident, and prevents the heat from escaping. All the communication pipes in this case may be of lead, and fitted with union joints, which render the fitting exceedingly easy. In my apparatus a lead pipe of $1\frac{1}{4}$ in. diameter supplies 40 ft. of radiating surface, and my reservoir contains about four times as much as my pipes. Reservoirs may be made of iron, but, though rather less expensive, they are so heavy and unwieldy that they could hardly be used; and the expense of attaching the pipes would greatly exceed the cost of copper. I have a 72-gallon reservoir, a cylinder 4 ft. long by 2 ft. in diameter, which cost complete, with two $1\frac{1}{4}$ -inch union joints, *5l. 5s.*

The foregoing directions will, I believe, enable any intelligent gardener to plan and put up an apparatus for himself.

It remains that I should say something respecting fuel: any sort except wood and caking coal may be employed. The best of all is anthracite or Welsh coal, but a little coke is necessary to light it; the next best is coke; and next to this, cinders. I arrange them thus, in the order of their strength; but for ordinary purposes nothing is better than cinders, — nay, even coke breeze, or small refuse coke, the value of which is next to nothing, may be burnt in these furnaces, but in that case they require 8 or 10 feet of chimney. Where it is required to produce strong heat rapidly, coke must be employed; but it is not a good fuel to maintain heat, as it allows too much draught, and burns away. Welsh coal has not this fault, and is a very durable fuel, peculiarly well suited to these boilers. When the fire is first lighted it should be allowed to burn brisk and clear, till the fuel in the bottom is well ignited; it may then be filled up to the

throat of the furnace, when it will last through the night. In filling, care, of course, must be taken that the fuel is not so small and dusty as to stop the draught. Where cinders are used they should be well sifted. The proper management of these boilers may be best secured by explaining the principle upon which they are constructed. As fuel cannot be consumed without air, if a furnace be constructed of considerable depth, and filled with fuel, and air be admitted only at the bottom, that fuel alone is consumed which lies immediately on the bars, and first receives the draught of air. The fuel above, provided it transmits the air, becomes red-hot, or nearly so, but does not consume until that below it is destroyed. In this manner, one of these conical furnaces being lighted and filled with fuel, that portion in the upper part of the furnace which cannot burn absorbs the heat of the burning fuel below, and radiates or transmits it to the water on every side. So perfect is this absorption of heat, that for several hours after the furnace has been filled up with cinders, though there may be a fierce fire below, little or no heat escapes by the chimney, the whole being taken up by the surrounding water. The economy, therefore, of fuel in such an apparatus is very great; and it is also evident that excess of draught must be carefully guarded against, so much only being allowed as will consume the fuel steadily, which is easily learned by experience. The necessity, also, of keeping the aperture in front close, so that air enters the furnace only through the ash-pit, is hence evident. The water, it will be observed, is in close and immediate contact with the red-hot fuel on all sides, no black smoking coals intervening, as in most kinds of boilers; hence the great power in proportion to their size.

Economy of fuel is not, however, the sole or principal advantage of these boilers; their great recommendation is the long duration of steady heat which they insure without attendance. When properly managed, they may be depended upon for maintaining heat 12 hours untouched. This to many amateurs, who do not command the services of a resident gardener, is invaluable. In the next place, they are applicable to houses and pits on the smallest possible scale; a three-light pit may be kept at a temperature as uniform as that of the largest hot-house, without any trouble by night. It was for a purpose of this kind that I was originally led to devise them, and I have for three years past cultivated *Orchidææ* in a small house not 12 ft. square in this manner. My gardener does not live on the premises; and the temperature, as ascertained by a double self-registering thermometer, rarely varies 5° during the night.

It is to be observed, that, as the quantity of heat produced depends upon the quantity of fuel consumed, each boiler must contain, at one charge, fuel sufficient to supply the pipes to

which it is attached with heat for twelve hours ; it is, therefore, necessary that the size of the boilers be proportioned to the work they have to do. They are cast in the following sizes, which have been found most generally useful : —

10-inch furnace, working	40 ft. to 60 ft.	4-inch pipe.
13-inch do. do.	60 ft. to 120 ft.	do.
15-inch do. do.	120 ft. to 200 ft.	do.

Where the quantity of pipe exceeds the above amount, two boilers have hitherto been employed ; but there is no reason why an 18-inch should not be cast, if a sufficient demand arose for them : boilers of this size have been found very effective in copper ; and a 21-inch, cast in iron for Mr. Wilmot of Isleworth, worked exceedingly well. The numbers affixed to the boilers above are such as they will work properly and efficiently at all times. I am aware that some of the above dimensions have been found to do a good deal more work than is here allotted to them ; but this has only been by increasing the draught, and producing more intense combustion, a great deal of heat at the same time escaping by the chimney. When thus employed, the peculiar advantages of these boilers are lost ; fuel is burnt to waste, and consumed so rapidly that they do not maintain their heat as long as is desirable. Duration of heat and economy of fuel I consider paramount objects.

The only case in which stronger draught may be allowed is where the fire works into a flue in the house : but the objection of the rapid consumption of fuel is not thus removed ; nor can I generally recommend this arrangement, though sometimes convenient.

When the 10-inch boiler is employed to small quantities of pipe, it must be fitted with a reservoir, as in *fig.* 28. In this manner it may be made to work as low as 15 or 20 feet of 4-inch pipe.

4-inch pipe is taken as a standard, because each foot of it contains about one square foot of radiating surface. Of 3-inch, one third more, and of 2-inch, double the quantity, may be considered as the equivalents of the above amounts.

Before quitting the subject, I ought to observe that these boilers are so constructed that they can be cleaned out ; and, if necessary, they can be taken to pieces, to remove any calcareous deposit which may in time take place in them. It is, however, particularly desirable, in these, as in all hot-water apparatus, that nothing but pure rain or pond water should be employed. Where the boilers are employed for steaming, this precaution is particularly important, otherwise calcareous incrustation must take place. To prevent leaves, dirt, &c., getting down the pipe of the supply cistern, it should be guarded by a double cap of

pierced zinc; one movable, that the gardener may cleanse it if clogged, and the other fixed.

The advantages of these conical boilers are no longer matter of speculation or experiment. My own, and several others constructed under my instructions, have been in use between three and four years. Of the iron ones very many have been erected in the course of the last eighteen months, and are highly approved; although few of them possess all the advantages which experience has since combined in the form now described. They are peculiarly adapted for those purposes where perpetual heat is required, for plant stoves, pineries, and forcing-frames; also for small propagating-houses, or preserving-pits. To pits in general, from their small size, and from the small expense incurred in setting them, a recommendation not heretofore noticed, they are peculiarly applicable, and have been extensively applied. That employed in the half-hardy pit in the Horticultural Society's Garden, at Chiswick, is a fair specimen of their application, though that boiler is capable of doing considerably more work than is now allotted to it.*

Sevenoaks, February 7. 1840.

ART. XIII. *Description of a Forcing-Pit heated by hot Water.*

By JOHN ROGERS, JUN.

THE cultivation of melons, cucumbers, and pines by steam, instead of by dung or tan, has long been successfully practised in those establishments, which are of sufficient magnitude to admit of the introduction of steam apparatus. But steam-boilers exist in comparatively few gardens, and in many places where they were formerly employed they have given place to the more economical and commodious contrivance of hot water. It has become, therefore, an important consideration, to devise the best mode of employing this last agent to supply at once top and bottom heat, combined with that degree of moisture requisite in early forcing; and, as yet, such a contrivance seems to be a desideratum in horticulture.

The annexed sketches are the plan and section of a pit, by which it is proposed to attain these objects in the most efficient and economical manner, and at the same time to secure certain other effects which may by some persons be deemed of con-

* I annex, according to your request, the prices of the conical boilers, with which Mr. Shewin has furnished me: — 10-inch, 4*l.* 10*s.*; 13-inch, 6*l.*; 15-inch, 7*l.* 10*s.* The fittings, comprising doors, dampers, &c., all things, in short, peculiar to the apparatus as above described, vary from about 1*l.* 5*s.* to 1*l.* 15*s.*, according to the size, and the articles required. The appendages for steaming the house are not included in the above.

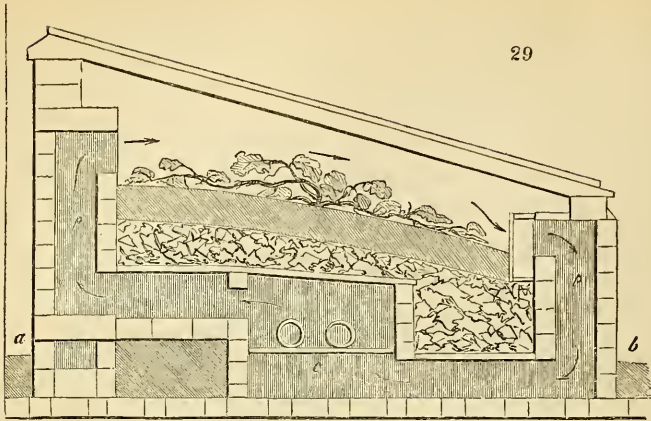

Section of proposed Pit on the line *a b* of fig. 30.

The arrows indicate the course of the circulating current.

siderable value. There is nothing in the plan which lays claim to novelty; it professes merely to be a combination of various expedients, already severally in use, but which have not, it is believed, been hitherto applied to any very efficient purpose.

Fig. 29. is a section of the proposed pit, which is supposed to be built entirely above ground; brick on edge with hollow walls. This mode of construction is not essential to the plan, but its economy recommends it whenever a pit is to be built anew.

Fig. 30. is a plan of the same, and *a b* is the line of the section shown in *fig. 29*. The following details will be best understood by keeping both plan and section in sight.

At certain intervals, say every 3 ft. 8 in. or 4 ft., corresponding with the rafters which support the lights, a hollow pilaster (*p p* in *fig. 30.*) is carried up inside the pit, projecting from the wall, the thickness of one brick only, and so constructed as to have no communication with the general cavity of the wall; and an aperture is left in each of these pilasters, both at top and bottom, inside the pit. Along the centre of the pit, also above ground, is constructed a flue of 4-inch work, 2 ft. wide, and 18 in. deep, having an aperture at bottom corresponding with each aperture of the pilasters on the front, or lower, side of the pit, and an aperture just below its upper edge corresponding with each pilaster along the back; and these apertures are respectively to be connected by means of small brick flues, or, cheaper and better, by 6-inch draining-tiles, with the apertures in the pilasters with which they correspond. The space between the flue and the back wall may be filled up with earth or rubbish, and trodden firm before the cross flues are laid; that between the flue and the front wall should be filled with brickbats, stones, or with

30

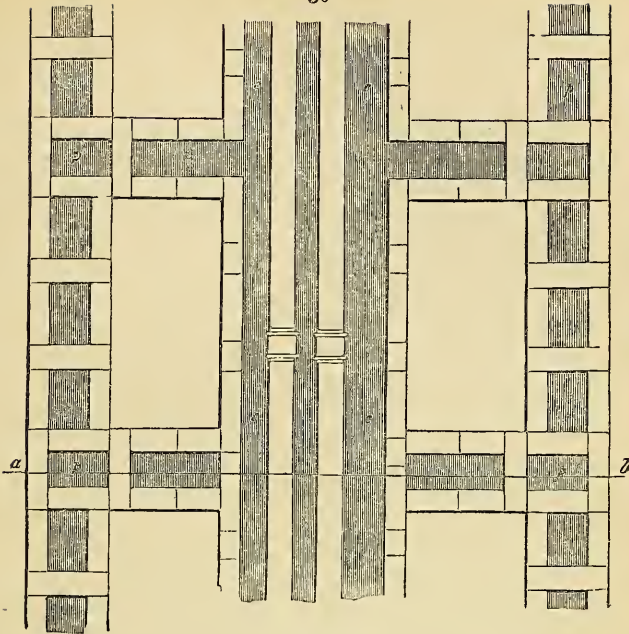

Ground Plan.

p p, Hollow pilasters; *c c*, air-chamber, or flue for the pipes.

coarse dry rubbish. The heating-pipes, which should be not less than a pair of 4-inch pipes for a pit whose lights are 6 ft. long, are to be laid as usual, on small piers about 9 in. above the floor of the flue, which should be paved with bricks or tiles, or else trodden very firm. The flue is then to be covered in with $\frac{3}{4}$ -inch slate (Valencia slate is best and strongest) in slabs. The apertures of the flues leading to the back pilasters must be 3 in. below the top of the flue, to retain a stratum of heated air in contact with the slate; and the pilasters should correspond with the rafters of the pit, thus interfering least with the general arrangement. The boiler, for which purpose one of the conical boilers described p. 132. is admirably adapted, must be placed in an ash-pit, sunk at one end of the pit; unless, indeed, hot water can be laid on from some existing apparatus near at hand.

In finally preparing the pit for the operations of culture, the space between the flue and the front of the pit is to be filled, and the whole surface of the pit over the flue is to be covered, with stones or brickbats free from dirt, and coarse gravel, diminishing in size upwards till they be of the size of pigeon's eggs or rather less. The depth of this layer over the flue should not exceed a foot;

over this should be placed a layer of turf with its grassy side downwards, where it is intended to cultivate melons or cucumbers; for pines or plants in pots, fine gravel or coal-ashes should be employed, in which the pots might be plunged. The pit is now complete. When the fire is kindled and the pipes heated, the air in the flue or chamber *c* being heated, will rise to the top of the flue, and imparting some of its heat to the slate above, will proceed up the cross flue and pilaster *p*, and be poured out into the pit; its place below being supplied by the cooler air from the front, or lower, side, descending by the hollow pilaster in front to be heated in its turn by the pipes below. The slate, being an excellent conductor, will transmit abundance of bottom heat. It will, of course, take a few days, after the apparatus is set at work, before the mass of rubbish, &c., becomes thoroughly warmed, after which it will be subject to little variation.

All moisture in the pit, produced by watering or otherwise, will gradually sink down to the central flue, towards which the floor of the pit should slope from both sides. On arriving at this flue the moisture will be immediately taken up by the air heated by the pipes, and, being brought up as it circulates, will be deposited by the cooling air in the pit above. The arrows in *fig. 29.* indicate the course of the circulating air.

By this arrangement, it will be perceived, three things are attained: bottom heat; top heat, with an atmosphere constantly moist; and, finally, a constant circulation of air. Unless I am much mistaken, supposing the pit to be 6 ft. wide and 3 ft. high at back, and 1 ft. 3 in. in front, above the mould, the whole atmosphere of such a pit would pass through the flues once in every two minutes, when the apparatus was in full work, thus producing a constant and vigorous circulation. Further, if it be desired to change a portion of the air continually, small apertures to the outward air may be made in the front descending flues; a small portion of fresh air will then pour in, continually mingling with the descending air, and ascending heated into the pit, supplying the place of that which will escape through unputtied laps, and various crevices. The internal areas of the pilaster flues should not be less than 6 in. square, which they may be according to the proposed plan; and the cross flues and the apertures into the pit must have the same area. If it be found that, with this area or aperture, the heat produced by the pipes is brought up too rapidly, not leaving sufficient bottom heat, and overheating the top, these apertures may be diminished. If they be too small, an inequality will arise between the temperature of the back and front of the pit, caused by an excessive difference of the ascending and descending air. The total heat brought up will be the same, for, as the heat increases, the velocity with which the air will ascend will increase also; but, if apertures of

the size above recommended be employed, there will not be 2° difference between the front and back of the pit. In order the better to disperse the ascending currents, it may be well that the aperture, instead of opening directly into the pit, should have a semicylindric draining-tile placed in front of it, to throw its draught right and left: but this is an unnecessary refinement; a pair of 4-inch pipes will, I believe, be found sufficient for cucumbers, melons, or pines, in a 6-foot pit. My experience shows me they will produce 30° of temperature, which, as such pits are always covered at night in frosty weather, would be quite sufficient, except for very early forcing; for which purpose two pair (i. e. four rows) of 3-inch pipes would be preferable.

There is one portion of the above-suggested plan so evidently borrowed from an arrangement employed by Mr. Penn of Lewisham, at Wilmot's of Isleworth, and probably elsewhere, that it appears due to Mr. Penn both to acknowledge the source from which it is derived, and to point out, at the same time, wherein I conceive the proposed plan an improvement upon his.

Mr. Penn lays his pipes in flues, or tunnels, as above described, either at the front or back of the house, and causes the air to circulate in tunnels passing under the house. The arrangement is ingenious, and the circulation very complete; but considerable expense is incurred, and it does not appear that any great advantage is attained by it. It is stated that a very salutary circulation of air is obtained; but precisely the same circulation takes place in every house heated by pipes, only more freely if the pipes are not encased: any one who has steamed a house by syringing the pipes can bear testimony to the rapid circulation of the atmosphere, ascending along the roof, and descending by the back, till it returns across the house, or along the floor to the pipes.

Now, in the arrangement of the pit above suggested, there is a reason for encasing the pipes in a flue; viz., to obtain from them bottom heat, an advantage neither obtained nor sought in Mr. Penn's arrangement. A collateral advantage is the getting rid of the pipes, which are always exceedingly in the way in a small pit, burning up the plants near them. A third great advantage is, the constant supply of moisture brought up from below by the air, all the moisture of the pit draining down to the pipe flue; and a fourth, the regular circulation, an advantage which I am not disposed to despise, though I do not think it of such value as to be worth much expense in attaining.

In conclusion, I would remark that any existing pit may be fitted up on the principle above recommended, simply by building a centre flue, and forming the cross and ascending flues of draining-tiles.

It may be objected to this plan, that the ascending flues should be at the front rather than at the back, lest the upper part of

the pit should be warmer than the front. The extreme rapidity of the circulation, already alluded to, is a complete answer to this objection; but, further, any other arrangement of the circulation than that above suggested would be prejudicial, and lead to precisely the opposite results to those intended. In the first place, instead of a great, there would be but a small, difference between the height of the ascending and descending columns, and, consequently, a much slower circulation. In the next place, if the descending flues were at the bottom of the back instead of at the front, and the heated air entered in front, it would immediately rise to the upper part of the pit, and there accumulate its heat, while the whole surface occupied by the plants would be covered by the coldest air. Moreover, the earth at back being always higher than the front, the coldest air would not flow away to be reheated, but would lie all along the front of the pit, and scarcely circulate at all; whereas, by the arrangement proposed, the coldest air will always descend to be heated, while the influx of warm air, constantly encountering the warmest air which has risen to the top, will beat it down, and mingle it with that below. This is, perhaps, theory, but it is theory based on experience, and I have no hesitation in saying that such would be the effects.

I am induced to make these remarks, because the objection combated above is very likely to occur to any intelligent person perusing this plan; and has, in fact, already been made to me by one to whose judgment I should, without good cause to show to the contrary, willingly defer.

It would prolong a paper already of unseemly length, to point out the manifold convenience of such a pit. Its application to pines and Orchideæ, strawberries, &c., is obvious: it may also be employed as a preserving pit; for, when the apparatus is in full work, the bottom heat alone, with the assistance of a mat, would keep out any frost from a part devoted to geraniums: while, the air-flues of that part being closed, the heating power of the pipe corresponding with them would be expended with accumulated force of circulated air in the forcing-pits which were at work, supplying them with more than their average amount of heat at a season when they most require it.

Sevenoaks, February 9. 1840.

ART. XIV. *Botanical, Floricultural, and Arboricultural Notices of the Kinds of Plants newly introduced into British Gardens and Plantations, or which have been originated in them; together with additional Information respecting Plants (whether old or new) already in Cultivation: the whole intended to serve as a perpetual Supplement to the "Encyclopædia of Plants," the "Hortus Britannicus," the*

“*Hortus Lignosus*,” and the “*Arboretum et Fruticetum Britannicum*.”

Curtis's Botanical Magazine; in monthly numbers, each containing seven plates; 3s. 6d. coloured, 3s. plain. Edited by Sir William Jackson Hooker, LL.D., &c.

Edwards's Botanical Register; in monthly numbers, new series, each containing six plates; 3s. 6d. coloured, 3s. plain. Edited by Dr. Lindley, Professor of Botany in the London University.

Paxton's Magazine of Botany, and Register of Flowering Plants; in monthly numbers; large 8vo; 2s. 6d. each.

The Floral Cabinet; in monthly numbers, 4to; 2s. 6d. each. Conducted by G. B. Knowles, Esq., M.R.C.S., F.L.S., &c., and Frederick Westcott, Esq., Honorary Secretaries of the Birmingham Botanical and Horticultural Society.

The Botanist; in monthly numbers, each containing four plates, with two pages of letterpress; 8vo; large paper, 2s. 6d.; small paper, 1s. 6d. Conducted by B. Maund, Esq., F.L.S., assisted by the Rev. J. S. Henslow, M.A., F.L.S., &c., Professor of Botany in the University of Cambridge.

Maund's Botanic Garden, or Magazine of Hardy Flower Plants cultivated in Great Britain; in monthly numbers, each containing four coloured figures in one page; large paper, 1s. 6d.; small, 1s. Edited by B. Maund, Esq., F.L.S.

PITTOSPORA[\]CEÆ.

3484. SO[\]LLYA
linearis Lindl. narrow-leaved 𐀀 𐀁 or 5 s.n B Swan River 1839. C l.s.p Bot. reg.

The present species differs from *S. heterophylla* in the intense blue, large size, and great abundance of its flowers, and in its “exceedingly narrow leaves, which have no appearance of having been ever serrated.” It is also “a more slender-looking plant.” It was found in the Swan River Colony by Drummond and others, and was introduced by Robert Mangles, Esq., of Sunning Hill. Cuttings root slowly. Under this head, Dr. Lindley mentions that the plant called *Sóllya angustifolia*, the *Billardiëra fusiformis* of Labillardière, proves to be a very slight variety of *S. heterophylla*, having nothing to distinguish it from that plant but “a few long hairs on the young twigs, and on the back of some of the leaves, of which there is a trace on the younger leaves of *S. heterophylla* itself.” (*Bot. Reg.*, Jan.)

Balsaminacææ.

698. IMPA[\]TIENS
+macrochlla Lindl. long-lipped O or 8 jl.au Pk India 1839. S co Bot. reg. 1840, 8.

A tall, and rather weedy-growing plant, with very large pink flowers. A native of the North of India, and requiring no other care than sowing in the open ground. (*Bot. Reg.*, Feb.)

+tricornis Lindl. three-horned O or 6 jn.au Y India 1839. S co Bot. reg. 1840, 9.

A very beautiful yellow-flowered species, which derives its name of three-horned from the shape of the flowers. Under this head, Dr. Lindley remarks, that the *I. picta* of the *Floral Cabinet* (see p. 19.) is the *I. longicornu* of Dr. Wallich. A very interesting quotation is given from a paper on the genus *Impatiens*, written by Dr. Wight, which appeared in the *Madras Journal* for January, 1837; by which it appears, that “at least a hundred species occur in those districts, from which Roxburgh described only three.” Many of these grow in situations having a mean summer temperature, “not exceeding 70°, if so much.” Dr. Wight mentions one circumstance which, “in a physiological point of view, is exceedingly curious. It is, that most of the

species from the colder regions of the Himalaya Mountains, correspond with the European *I. Nolitangere*, in the forms and dehiscence of their capsules; that is, they split from the base, rolling the segments towards the apex, while those of the warmer regions split from the apex, and roll their segments towards the base." (*Bot. Reg.*, Feb.)

Onagræcæ.

1188. *FUCHSIA* *fùlgens* globòsa *Bot. Reg.* 1840, 2.

A very handsome hybrid, raised from seeds of *F. globòsa* fecundated with the pollen of *F. fùlgens*, and "completely intermediate between the two parents." "It was raised by Mr. John Standish, nurseryman, Bagshot." It is an "exceedingly free bloomer, with a stiff, erect habit of growth," and the whole "plant is very handsome." (*Bot. Reg.*, Jan.)

Philadelphæcæ.

3543. *DEUTZIA* *corymbòsa* *R. Br.* *corymb-flowering* 卐 or 5 jn W Nepal 1838. C co *Bot. reg.* 1840, 5.

A very beautiful species of *Deutzia*, forming a handsome bush 4 or 5 feet high, covered with a profusion of white, lemon-scented flowers, in loose corymbs. The plant grows well in the open border; but it may be forced in the same manner as Persian lilacs, &c., and it is a valuable plant for that purpose. It was introduced by Mr. H. Low of Clapton, who received it from Dr. Von Sieboldt; and there are plants in the Horticultural Society's Garden. Dr. Lindley considers the *D. parviflora* of Bunge to be hardly distinct from this species. (*Bot. Reg.*, Jan.)

Passifloræcæ.

1923. *PASSIFLORA* *Mooreana* Hook. *Mr. Moore's* 卐 cu 20 W jl Buenos Ayres 1837. C co *Bot. mag.* 3773.

Not very handsome, but fragrant; and apparently as hardy as *P. cærùlea*. The seeds were sent home by Mr. Tweedie in 1837; but the plant did not flower till July, 1839. (*Bot. Mag.*, Jan.)

Rubiæcæ.

378. *BOUVA'RDIA* *spléndens* *Graham* splendid 卐 卞 or 2 ap.n S ? Mexico 1838. D co *Bot. mag.* 3781.

Very nearly allied to *B. triphýlla*, but of freer growth, and with much more splendid flowers. The leaves are also more scabrous, longer, and more acuminate; and the style is exserted. The native country of this species is not known with certainty, but it is probably Mexico. Mr. James M'Nab has not been able to propagate it by cuttings, "but has found it very easily increased by slips from the roots not $\frac{1}{2}$ in. long, and covered so as to leave the upper extremities, only, exposed, and level with the surface." (*Bot. Mag.*, Feb.)

Compòsitæ.

3408. *ECHINACEA* *dùbia* *Kn. & West.* doubtful 卐 卞 or 4 s.o Li Mexico 1837. D co *Flor. cab.* 131.

A very showy tuberous-rooted plant, a native of Mexico; resembling in general appearance *E. heterophýlla*. It requires protection during winter; but, "from the appearance of the roots, it is probable that they might be preserved like dahlia and *mirabilis* roots, by being stowed away dry in a cellar." (*Flor. Cab.*, Jan.)

Lobeliæcæ.

Lobèlia multiflora Know. et West. A specific character was given of this *Lobèlia* some months since in the *Flor. Cab.*, and it is now repeated in the *Bot. Reg.*; but no particulars are stated as to the colour of the flowers, or the height or native country of the plant. (*B. M. R.*, No. 17., Feb.)

Campanulæcæ.

611. *PHYTEUMA* 30473 *pulchèllum* *Bot. Gard.* No. 728.

Epacrideæ.

Lissánthe stellata Know. et West. A species with white flowers, which wither as soon as gathered. It is in the Birmingham Hort. Soc., "and was

raised from the seeds collected in New Holland, and presented to that establishment in the year 1836." (*Flor. Cab.*, p. 79.; and *B. M. R.*, No. 13., Feb.)

Gesneriæcæ.

GLOXI'NIA speciosa-caulescens *Bot.* No. 149.

A hybrid between the white variety of *G. speciosa* and *G. caulescens*, the latter producing the seed. Under this head it is observed, that "the colour of the flowers is mostly determined by that parent which supplies the pollen, while the foliage and organs of vegetation generally resemble those of the parent that furnished the ovules. The more it resembles the latter, the more likely are its seeds to be fertile." (*Botanist*, Jan.)

Apocynæcæ.

+MANDEVILLA Lindl. (In honour of "H. J. Mandeville, Esq., H.B.M. minister at Buenos Ayres, to whom we are indebted for the introduction of this and many other interesting plants.")

1840, 7.

suaveolens Lindl. sweet-scented $\frac{1}{2}$ \square or 20 in. au W Buenos Ayres 1837. C co Bot. reg.

This very beautiful climber was first sent home under the name of the Chile jasmine. The flowers are large, of a pure white, and "most deliciously sweet." It is too tender to bear the open air during winter in this climate; but succeeds best in a conservatory, with its young shoots trained "to their utmost length, as it is always near the ends of the shoots that it blooms. After the flowering season is over, the plants should be pruned back, in the same manner as vines, and other plants which bear their flowers and fruit upon the wood of the same year. It is easily propagated from cuttings." (*Bot. Reg.*, Feb.)

Gentianæcæ.

794. GENTIANA 6353 gelida *Pact. Mag. of Bot.* vii. p. 5.

Cobæcæcæ.

498. COBÆA

[3780.

+macrostema Hook. long-stamened $\frac{1}{2}$ \square or 20 n Y.G Guayaquil 1839. S co Bot. mag.

Synonymes: *C. lutea* D. Don in *Ed. Phil. Journ.* 1824; *C. acuminata* Dec.

This very interesting plant was raised from seeds sent home by Mr. Skinner in the spring of 1839, and it flowered in the conservatory of the Glasgow Bot. Gard. in November in that year. It will, however, probably prove as hardy as the well-known *C. scandens*. The flowers are of a yellowish green; but the filaments of the stamens are red; and both the stamens and the style are very long and exserted. (*Bot. Mag.*, Feb.)

Convolvulæcæ.

491. IPOMÆA

Learii *Pact. Mr. Lear's* $\frac{1}{2}$ \square or 30 s Dk.R Ceylon 1839. C co *Pact. mag. of bot.* vi. 267.

At first sight this *Ipomæa* greatly resembles the beautiful *I. rubro-cærulea*, but it differs in having the stem clothed with hair, and the leaves, which are often deeply cut, covered with pubescence; and in the stems being shrubby. It grows freely, the length of the strongest shoot being full 30 ft.; and cuttings taken from the young branches root with great readiness. This species was imported by Mr. Knight of the Exotic Nursery, and it is named in honour of Mr. Lear, his collector in Ceylon. (*Pact. Mag. of Bot.*, Jan.)

Scrophulariæcæ.

1717. PENTSTEMON 30424 argutus *Pact. Mag. of Bot.*, vi. p. 271.

Verbenæcæ.

1749. VERBENA

amœna *Hort.* pleasing $\frac{1}{2}$ \square or 1 s.n P ? Mexico 1839. C co *Pact. mag. of bot.* vii. p. 3.

A pretty species of *Verbena* nearly allied to *V. tencrionides*, but with the flowers in a denser spike, and with numerous, and very conspicuous bracteas. The leaves are pinnatifid, and the habit of the plant partly trailing, with upright flowering shoots. It seems tolerably hardy, and will, no doubt, prove well adapted for planting out in beds. (*Pact. Mag. of Bot.*, Feb.)

Acanthæcæ.

1734. THUNBERGIA

[bot. vi. p. 269.

aurantiaca *Hort.* orange-flowered $\frac{1}{2}$ \square or 4 o.n O C. G. H. 1838. C s.p.l *Pact. mag. of*

Differing from *T. alata* only in the colour of its flowers, and their somewhat larger size. (*Part. Mag. of Bot.*, Jan.)

3563. *GOLDFUSSIA*
glomerata *Nees von Esenback* crowded-flowered $\frac{1}{2}$ □ or 1 n P Silhet 1838. C p.l [155.
Bot.

A handsome species, nearly allied to *G. capitata*. Introduced by the Duke of Northumberland. It requires a stove heat, and "should be planted in a mixture of peat and loam." (*Botanist*, Feb.)

Begoniaceæ.

2654. *BEGO'NIA*
Barkeri *Know. & West.* Mr. Barker's $\frac{1}{2}$ □ or 4 ja W Mexico 1837. D p.l *Fl. cab.* 135.

A gigantic species of *Begonia*, which is remarkably tardy in the development of its flowers, "nine months having elapsed from the first appearance of the flower bud to the full expansion of its flowers." As the buds gradually open, a great number of dark brown scales are thrown off. It is propagated "by cutting out the buds found on the fleshy root, with a portion of the root attached," and striking them in sand. The best soil for growing the plant is loam mixed with peat. (*Flor. Cab.*, Feb.)

- 31536 *Mejeri Flor. Cab.* no. 130.

Proteaceæ.

316. *GREVILLEA* 30036 ferruginea *Bot.* no. 153.

Orchidaceæ.

2554. *EPIDENDRUM*
glumaceum *Lindl.* glumaceous $\frac{1}{2}$ □ or 1 jn W.pk Brazil 1838. D r.w *Bot. reg.* 1840, 6.

Agreeing with *E. fragrans* in habit and in the fragrance of its flowers, but differing in the shape and colour of its flowers. "It derives its specific name from the long, withered, sharp-pointed, ribbed scales, resembling the glumes of grass, out of which the raceme of flowers grows." (*Bot. Reg.*, Jan.)

- Parkinsonianum* *Hook.* Mr. Parkinson's $\frac{1}{2}$ □ or 2 s Y Mexico 1838. D p.r.w [3778.
Bot. mag.

A very showy species with golden yellow flowers, sent to Woburn by Mr. Parkinson, consul-general at Mexico, and named by Sir W. J. Hooker, in honour of that gentleman. (*Bot. Mag.*, Feb.)

+ *Eria planicaulis* *Wall.* Introduced in 1838 from India; and flowered in Sir Charles Lemon's collection in the autumn of 1839. (*B. M. R.*, No. 4., Jan.)

2530. *CATASE'TUM*
Russellianum *Hook.* *The Duke of Bedford's* $\frac{1}{2}$ □ cu 3 G Guatemala 1838. D p.r.w [Bot. mag. 3777.

The flowers are large and numerous, but not showy; as they are of a pale green, slightly striated with a somewhat darker shade of the same colour. The species was sent by Mr. Skinner from Guatemala to Woburn, where it flowered but a few days before the lamented death of the late Duke of Bedford; to whose memory Sir W. J. Hooker takes this occasion to pay a mournful tribute of respect; and in honour of whom he has given the specific name to this plant. (*Bot. Mag.*, Feb.)

5540. *ONCIDIUM* 22683 ornithorhynchum *Bot. Reg.* 1840, 10.; and *Fl. Cab.* 136.
Synonyme: *O. roseum Hort.*

This beautiful species is found to have pink flowers, instead of yellow ones, as marked in *Hort. Brit.*, p. 371. The flowers have the fragrance of new hay. (*Bot. Reg.* and *Fl. Cab.*, Feb.)

- Batemanianum* *Parment.* Mr. Bateman's $\frac{1}{2}$ □ or 2 Y Mexico 1838. D p.r.w *Fl. cab.* 137.

A very splendid species, allied to *O. altissimum*, but of much more brilliant colours. (*Fl. Cab.*, Feb.)

2537. *MAXILLA'RIA*
+cucullata hooded $\frac{1}{2}$ □ cu $\frac{1}{2}$ s Y.C America 1837. D p.r.w *Bot. reg.* 1840, 12.

One of the least-interesting species of the genus, approaching, "in its habit and general appearance," the *Trigonidia*. It is a native of Equinoctial America, whence it was sent home by Mr. Henschman. (*Bot. Reg.*, Feb.)

+ *Saccolabium compréssum* Lindl. The flowers are crimson and white, and they are produced in drooping racemes. (*B. M. R.*, No. 5., Feb.)

Cymbidium mádidum Lindl. The flowers are of a dull yellowish green, with a deep purple stain inside the labellum. (*B. M. R.*, No. 6., Feb.)

2547. DENDROBIUM Cambridgeanum Paxt. The Duchess of Cambridge's £ ☒ [p.r.w Paxt. mag. of bot. vi. p. 265. or 1 o Y.P Khoseea 1837. D

This beautiful species having blossomed for the first time at Chatsworth during the visit of the Duchess of Cambridge, it was named in honour of Her Royal Highness. It is a native of the Khoseea Hills, where it was found growing "at an elevation of 4000 ft, and attaching itself to rocks and trees. Although, when depending from objects of the latter description, an impenetrable shade is afforded in the growing season, it may be useful to state that it is frequently seen clinging to the faces of rocks in situations fully exposed to the rays of the sun." It will not thrive in an erect position; and at Chatsworth it is affixed to a large block of wood, and its roots covered with moss, "carefully secured with metallic wire." The best logs of wood for growing *Orchidéæ* are those on which the bark is perfect, rugged, and durable, "for the roots delight to insinuate themselves into the fissures of rough bark, and if this is subject to a speedy decay, or separates readily upon exposure to the frequent atmospheric changes of an orchideaceous house, the plant can be transferred to another block without great injury to the roots." (*Paxt. Mag. of Bot.*, Jan.)

Dendrobium plicátile Lindl., *D. fimbriátum* Lindl. Dr. Lindley has changed the specific name of this plant, in consequence of its having been "applied to a very different species." The present name alludes "to the very conspicuous plicatures of the labellum." (*B. M. R.*, No. 7., Feb.)

Mormodes buccinátor Lindl. The flowers are "pale green, with an ivory-white lip, whose sides are rolled back, so as to give it the appearance of a trumpet." (*B. M. R.*, No. 9., Feb.)

3590. LEPTOTES 30165 bicolor.

Professor Morren having succeeded in fruiting this species, by fertilising it artificially, finds that the fruit has the fragrance of the Tonquin bean; and that when infused in milk or cream, and iced, it gives "a mild agreeable flavour, sweeter than vanilla, but less penetrating." (*B. M. R.*, Feb.)

3536. CYCNOCHES maculáta Lindl. spotted £ ☒ or 1 d Pa.Y.R La Guayra 1839. Bot. no. 156.

The raceme of flowers is generally from a foot to 18 in. long; and the flowers are of a pale yellow or straw colour, with claret-coloured spots. The species is a native of South America, whence it was sent home in April, 1839, by Mr. M'Kenzie, collector to Messrs. Low, of Clapton. It flowered for the first time last December, in the orchideous house of John Willmore, Esq., of Oldford, near Birmingham. (*Botanist*, Feb.)

Scitaminàcæ.

14. CURCUMA Roscoeana Wall. Mr. Roscoe's 3 ☒ spl 1 au.d S.V E. Indies 1837. D ls [bot. vii. p. 1. Paxt. mag. of

It is hardly possible to conceive any thing more brilliant than the colours of the flowers and spathes of this species; while its dwarf habit renders it more convenient for cultivation than most of the other species of the genus. It was imported by Messrs. Loddiges in 1837, but it is by no means common in collections. It should be grown in "a rather rich compost, composed almost entirely of maiden loam and sand;" and, though it should be kept in a moist atmosphere till the flower spike appears, "a dry position is indispensable while the flowers and their appendages are unfolded, as they are apt to become mouldy in a very humid air, owing to the lateness of the season at which they are produced." The species is readily propagated by suckers, which are every season thrown up by the roots. (*Paxt. Mag. of Bot.*, Feb.)

Iridàcæ.

+GELASINE Herb. (*Gelasinos*, a smiling dimple.)
azúrea Herb. blue 3 ☐ pr 1 my B S. America 1833. D s Bot. mag. 3779.

A bulbous-rooted plant, with rather small dark blue flowers. It was found by Mr. Tweedie in stony places, near Rio Grande. "The seedlings grow rapidly, and will probably flower at a year and a half old." The specimen figured flowered in the green-house at Spofforth; but Mr. Herbert thinks the species will prove very nearly hardy, and will retain its leaves, "in part at least, through the winter." Mr. Herbert also mentions five other species of *Gelasine*, viz. *G. purruchucana* (two forms), *grandiflora*, *punctata*, *nuda*, and *texana*; and three species of *Nemostylis Nutt.*, a very nearly allied genus. He then describes three new genera: *Alòphia*, *Trifúrcia*, and *Beatònia*, the last of which Mr. Herbert has named in honour of our excellent friend, Mr. Beaton; observing that he saw the species he has described in flower in one of the houses of T. Harris, Esq., under the care of that gentleman's skilful gardener, Mr. D. Beaton (curante hortulano perito D. Beaton). Mr. Herbert also gives the botanical description of a new genus, *Hylène*, belonging to *Amaryllidaceæ*, and of *Cyrtánthus Smithianus*, and *Habránthus cearénsis*; and he concludes by remarking that "the attention of collectors should be called to a fine *Tigridia*-like plant, perhaps a *Rigidella*, found by Audrieux near the ice-house on the summit of the mountain San Felipe, in Oaxaca." (*Bot. Mag.*, Feb.)

142. *TRIS* +fràgrans *Lindl.* fragrant ✱

A very distinct species, a native of the North of India, where it was found by Professor Royle. The flowers are lilac and white, and they are fragrant. The species is quite hardy, as it stood the winter of 1837-8 without protection, and it requires the same treatment as *I. sibírica*. (*Bot. Reg.*, Jan.)

Amaryllidææ.

669. *AMARYLLIS* 7989 *solandraflòra*.

Synonyme: *Hippeastrum solandriflòrum* Herb., *Bot. Mag.* 3771.

Bromeliæææ.

955. *POURRETIA* 29152 *cærùlea*.

Synonyme: *Ptya cærùlea* Mol., *Bot. Reg.* 1840, 11.

3492. *ÆCHMEFA*

suavèolens Kn. & West. sweet-scented $\frac{1}{2}$ □ or $2\frac{1}{2}$ fap Pk Brazil 838. D 1.p.s Fl. cab. [134.]

By some mistake, the only other species known of this genus, *Æ. Merténsis*, is marked in the *Second Additional Supplement to Hort. Brit.*, p. 607., as belonging to the order *Orchidæææ*; whereas it belongs to *Bromeliæææ*, and was in fact originally called *Bromèlia Merténsis* by Schultes. The present species has a flower scape about a foot long, covered with pink flowers, which smell like orris-root. It was imported by E. W. Fry, Esq., and there are plants in the Birmingham Botanic Garden. It requires a stove, and it should be grown in a compost of loam, peat, and sand. "When the plants are grown to a sufficient size, they can be forced into flower by being kept without water for some weeks, and afterwards having a regular supply, with an increased degree of heat." (*Flor. Cab.*, Feb.)

ART. XV. *Observations on the Rotz, a Disease in Hyacinth Bulbs.*

(Translated from the "Verhandlungen des Vereins," &c., of Frankfort on the Maine, by J. L.)

THE Rotz, or Rot, is a disease which causes a dreadful destruction among the hyacinths; and it is much to be lamented that we have not hitherto been able to account for its existence, nor to give a certain remedy for its prevention. A considerable time back the sum of two thousand ducats was offered for a remedy for this disease, which has thrown considerable light on

the subject, but unfortunately it has not been ultimately attended with any beneficial effects.

We, however, know this much, that the rotz generally begins in spring, when there is fine warm weather, accompanied by a north wind; because by that means the sun warms the earth during the day, and it freezes again at night, which causes a very unequal, and probably injurious, temperature to the hyacinths. This may be easily prevented where the beds are small, because they can be covered; but how is it possible to do so to the very extensive plantations of the Haarlem florists? Hedges might certainly protect them against the wind, but would not protect them long enough against variations of the atmosphere; particularly as the soil intended for hyacinths is very easily heated or cooled by the changes in the air.

This disease is also prevalent when the bulbs are put in too stiff a soil, and thereby grow too strong; but of this, and the means to prevent it, we have already spoken.

This disease also appears, and makes great devastation, while the bulbs lie in the *Käuil*. Certainly a great deal depends upon circumstances; and as we know that hyacinths are very liable to such attacks, they should be very delicately handled, which is not always the case. They must not be let fall, or get any bruises, as either would injure them very materially. No kind of litter, such, for instance, as their own leaves, &c., should be suffered to be near them; and they must be so laid in the *Käuil*, that one may not touch the other, so that the strength of any of them may not be diminished. They must not be allowed to be wetted by rain, or burnt by the rays of the sun. If the weather is too wet or variable, they must be taken out of the *Käuil* sooner than usual. These, and all other particulars, depend upon circumstances; and the more these are studied, the nearer will the object in view be obtained.

This is such a contagious disease, that if one bulb in a bed be attacked by it, and suffered to remain, it contaminates those of the third or fourth year; therefore the rule is, to plant hyacinths, at most, only every four years on the same bed, or to take out the old earth and to fill it with new, if you intend to plant the bed again.

The white rotz is quite as dangerous as the black rotz, although the latter is more prevalent, and all bulbs so attacked must be thrown away; but it is often the case that a very valuable bulb is but slightly attacked, and when that is the case, a simple remedy can be applied, viz., that of laying it in a place where snails abound, which are soon allured to it, and completely eat out all the diseased part, and leave the part that is healthy. The bulbs should then be set in the sun, where they will, in all probability, be cured of their disease. Some kinds

of hyacinths, scillas, ornithogalums, and narcissi are sometimes attacked by the rotz.

A trial has been made of strewing saltpetre in the ground, so as to prevent the rotz, but the result was very unsuccessful, and the disease was found to be increased, instead of diminished.



ART. XVI. *On Hyacinths, the Flowers of which appear expanded in Water.* By A. B.

OF late years, it has been common in the London seed shops, to observe hyacinth glasses with the plants inverted, the flower appearing expanded in the water, where the roots usually are, and the bulb and roots being contained in a small pot of soil, turned upside down, and resting on the orifice of the glass. This is not shown with much effect in water glasses of the ordinary size, but when glasses are made twice or thrice the usual size, the effect is more striking; though it is merely the same thing on a larger scale. Sometimes a glass appears with one inverted plant, with its flowers fully expanded in water, and another plant directly over it, growing erect, with its flowers fully expanded in the open air; the bulbs and roots of both plants being in the same pot, or in two pots, placed bottom to bottom.

By what means are the blossoms made to expand in water? They are made to expand first in air, in one of two ways: first, by the common mode of growing hyacinths in pots, and when the flower is expanded, introducing it into the glass, and filling it up with water; and secondly, by inverting the pot over the top of the glass, and tying it in that position after the bulb is planted, so that the plant may grow into the glass, in which, of course, there is no water, and after the blossom has expanded there, introducing the water. A necessary precaution, according to this last mode, is to keep the glass, and of course the bulb, and the pot in which it grows, in a horizontal position, near the light, and to turn them as often as the hyacinth appears to be growing to one side.

With respect to the mode of growing hyacinths in water glasses, it is commonly thought to be necessary to change the water whenever it appears to become muddy, but, though this is frequently done in England, it is as frequently omitted in Holland, and the Dutch florists (we refer to Mr. Corsten and Mr. Lockhart, in London) say that they perceive no disadvantages from the practice.

London, February, 1840.

ART. XVII. *On the Cultivation of the Carnation at Forres Nurseries.*

By JOHN GRIGOR.

DURING the last eight or ten years the cultivation of the carnation in our nurseries at Forres, North Britain, has been extensive and successful. We therefore trust that a few remarks on our treatment of this most beautiful flower will not be destitute of interest to English growers, since our mode of culture is neither that which is generally practised in the South, nor that which many would consider well adapted to the North of Scotland. Previously to the year 1830, our stock of carnations consisted chiefly of the named sorts then known in the vicinity of London, whence we received them, and our treatment then was similar to that bestowed on the plant in that quarter, the soil being a composition of loam, vegetable mould, road sand, &c. The plants were generally grown in pots. With the exception of a few kinds of least value, the whole assumed an enfeebled and victimised appearance, were difficult to propagate even by laying, and apt to die during winter. With all our care and desire for the plant, we were unable to make its cultivation either ornamental or profitable. About the period referred to we received from a friend in France a parcel of 200 carnation seeds grown from select flowers; these were sown in the open ground in the month of May and produced about 160 plants, which were transplanted into beds in August following, and twelve months thereafter were in full bloom; about nine tenths of them were double, and a fourth part of the whole consisted of valuable flakes, bizarres, and picotees, equal to many named flowers, and far healthier than any carnations of equal quality we had ever seen. We have since had frequent supplies of seeds of like quality from France and Germany, &c. In growing seeds in this country we have uniformly found that the earliest blooms of a seedling double carnation, the first year that it flowers, will more readily produce seed than the flowers of after years. From the first blossoms of fine seedlings we have, in seasons not the most favourable, obtained well-ripened and valuable seeds, but we have never been able to gather seeds again from the same plant nor from its produce of layers. Seeds grown on bizarres and flakes frequently produce picotees. Our stock of stools, from which we propagate the various kinds of this plant, occupies about half an acre of ground, situated in an open and airy exposure without the shelter of walls, and the plants receive no covering at any season. The soil is strong, dark-coloured, and clayey, with a subsoil of blue clay, at the depth of 18 in. Water rises to within $2\frac{1}{2}$ ft. of the surface. The ground is therefore of that description generally termed "damp," and the weeds which it is most subject to produce are *Móntia fontàna* and *Cardàmine*

hirsuta, which indicate a soil cool and moist. Last winter, 1838-39, was said to be more injurious than usual to carnations in England and on the Continent; yet our stools, about 1500 in number, continued to present all that perennial verdure and luxuriance which mark the plants of a suitable soil and situation. The ground of the nurseries being very diversified, plants of the carnation have been tried on various qualities, such as dry, sandy, and mossy, but with little success. That which was found to destroy plants in the shortest time was a rich sandy soil, which had received much manure a year previous to its being cropped with carnations. In such, the plants grew well for one year only, and no description of manure is now employed. Some of the finest of the original seedling plants continue in vigour where they were transplanted, without manure, into newly trenched ground eight years since; and, in all appearance, will continue to flower in health for many years to come, without any treatment further than being tied up, and having their supernumerary flower stems cut off.

The laying of the plants takes place in the beginning of August, when a small quantity of river sand is mixed with the soil under the layers of a few kinds that are slowest to root. It may here be remarked, that the flowering of plants is in some measure interrupted and weakened by their being laid. The young plants are removed in October, and may be planted out any time in open weather previous to the beginning of May, having all rotten stumps and decayed substances cleanly removed. Perhaps there is no plant which, after having become sickly, is more difficult to get reestablished in health than the carnation; and, to sum up our experience in its growth and management, we attribute the luxuriance of the plants under our care to the circumstance of their having been recently propagated from healthy seedlings, cultivated in a soil peculiarly suitable, and never enfeebled by that which is not congenial to their growth.

Forres Nurseries, Dec. 1839.

ART. XVIII. *On the Culture of the Chrysanthemum.*
By JOHN THACKERAY.

I TAKE the liberty of making a few observations on the cultivation of that beautiful and late-flowering plant the chrysanthemum, for I feel assured that very few persons indeed have ever witnessed the magnificence and grandeur that it is capable of attaining. In consequence of its blooming at so late a season, it is quite impossible to do justice to the plant, without the aid of glass to protect the blossoms from snow, rain, wind, &c. In spring, I get my young plants from cuttings, or by dividing the

old roots: these are planted in small pots, and plunged into the ground in an open part of the garden. About midsummer I repot them into large carnation pots, and again plunge them as before. The compost is cow-dung and rich loam, half and half, and occasionally they are watered with dung water. During their growth I use the knife freely, and only allow one bud to remain on a stem, precisely as the fancier treats his prize carnations. In the first week in October I remove the pots into a vinery, where all the air is given by the sashes and ventilators being open; and in my house there is a pit that was built for succession pines, filled with old tan, and upon this I place my chrysanthemums. In the removal from the garden to the house, I take care that the roots that have made their way through the bottom of the pots are not injured, and they again strike into the tan. They are now kept moist with dung water, and under this treatment the blooms are some of them 5 and 6 inches in diameter. The pots are so arranged, that the colours are agreeably intermixed.

I am under a great obligation to Abel Ingpen, Esq., for furnishing me, in the most handsome manner (being an entire stranger), with some splendid varieties. There is one, in particular, "mirabile," that was as fine and as large as a dahlia. As Mr. Ingpen is, no doubt, a reader of your Magazine, I will just state that, in a few days after I had planted a fine collection of tulips, some villain made his way into the garden at night, and stole roots to the value of 250*l*. Amongst them was a new broken feathered bizarre, whose qualifications placed all others at an immeasurable distance. In fact, twenty years' search and experience, to say nothing of the great expense, have been disorganised to a most discouraging extent. Can you, Mr. Editor, or reader, suggest a mode to guard against a similar calamity?

The Forest, Nottingham, Jan. 13. 1840.

REVIEWS.

ART. I. *Dr. Lindley's Theory of Horticulture.* (See p. 92.)

[ON asking our esteemed correspondent, Mr. Beaton, for his opinion on this work, he sent us the following notice, which we have great pleasure in publishing.]

MY opinion of this work must be in a great measure superfluous; there can be but one opinion on the subject by all candid readers. It is Dr. Lindley's masterpiece as far as the garden is concerned. It will soon become as useful and indispensable to the gardener, as the compass is to the mariner. The compass, to be sure, will not teach a man navigation, neither will this book teach a man the gardening art. It is divided into two parts, the first of which "embraces the principal laws and facts

in vegetable physiology, as deduced in the investigations of the botanist; and the second, the application of those laws to practice, as explained by the experience of the horticulturist." In all this nothing of a speculative nature is indulged in; no theory acknowledged but that "which is founded upon direct experiment, and proved by the most satisfactory course of enquiry." In the first book, Dr. Lindley relies chiefly on his own intimate acquaintance with vegetable physiology, yet he never loses sight of the views of the greatest horticultural physiologist that the world has seen, T. A. Knight, Esq., late President of the London Horticultural Society, and he dedicates the work to the memory of that truly great and good man. If Mr. Knight were amongst us now, how delighted he would be to see this work; a work which the combined philosophy of Europe could not produce at the time he began his horticultural experiments. Even now, Dr. Lindley, with all the powers of his extensive mind, could not have been able for the task, had it not been through his connexion with the Hort. Soc. Garden. No, there is not another place in this country where he could make himself so thoroughly acquainted with the gardener's art. It is not philosophy, nor scientific research, only, which could produce such a work as this, but a combination of these with an intimate knowledge of the minutiae and manipulations of the gardener's art, with which the mere man of science can have little acquaintance.

If I had met with such a book as this twenty years ago, I would not have so many grey hairs in my head now. However, it is gratifying to know that the rising race of gardeners are not destined to go through such ordeal as we of the old school have been subjected to. Yet among our difficulties we had pleasures which must be denied to the rising race. We found out many secrets among plants, and many modes of superior management, which we enjoyed very much, but which are now looked on as mere matters of course. In those days the word *principle* was as accommodating to us as the word *constitution* is at this day to our politicians; that is, a *something* which might be applied to suit any person's views. In this state Dr. Lindley found us when he undertook to write this book for us, as he plainly tells us in the second paragraph of his preface.

"There must be a great want of sound knowledge of this subject, when we find an author, who has made himself distinguished in the history of English gardening, giving it as his opinion, that the weak drawn state of forced asparagus in London is occasioned by the action of the dung immediately upon its roots!" (*Pref.*, p. vi.)

It is obvious to all the world the doctor means you in this paragraph.* He surely cannot mean Glenny; and really, after all the

* We thought so too, when we first read the paragraph; and it is quite

papers we sent you on forcing asparagus and all other plants, if you cannot force asparagus without "drawing them up," you deserve hard *hitting*. He very properly accounts for this by "referring to the want of some short guide to the horticultural application of vegetable physiology." Such a safe guide is now no longer wanting; neither is it filled with any thing which a gardener may not prove for himself; but here the author kindly cautions him not to apply these rules, "except in a limited manner, and by way of safe experiment, until he fully understood them." This is exceeding good advice.

As the work must soon come into universal use among gardeners, and the patrons of gardening, it is needless to quote from it in this place: let us therefore content ourselves by looking over the different chapters, and see how far our old views correspond with the real correct views of the case. The young reader here must be put in mind of the *convenient principle* to which many of the old gardeners are so much inured; viz. that principles laid down by the finger of science must in many instances be thrown away on us, and I fear some of us must die in our obstinacy. The young beginner must rigidly guard against this, and endeavour to prove for himself any doubtful cases which may arise in our progress. Dr. Lindley begins with the seed, and follows it till it complete the circle of its existence, and produces seeds "after its kind." Many kinds of plants do not verify this adage, especially the cultivated varieties of fruit trees.

"But while it will with certainty become the same species as that in which it originated, it does not possess the power of reproducing any peculiarities which may have existed in its parent. For instance, the seed of a Green Gage plum will grow into a new individual of the plum species, but it will not produce the peculiar variety called the Green Gage. This latter property is confined to leaf-buds, and seems to be owing to the seed not being specially organised after the exact plan of the branch on which it grew, but merely possessing the first elements of such an organisation, together with an invariable tendency towards a particular kind of developement."

There is a disposition in all plants to deviate from their original types, and the farther they are removed from their original nature, their tendency to this variation increases. This has hitherto baffled all scientific research; but the author, as far as science can penetrate, explains all the collateral circumstances connected with every stage of the existence of a plant; and

likely that we may have quoted this opinion, and adopted it in some of our works. However, having looked over the *Encyc. of Gard.*, and not been able to find such a passage, we applied to the doctor, who informed us that the sentence does not apply to us, but to a paper by Mr. Sabine, in one of the early volumes of the *Horticultural Transactions*. Notwithstanding this, we by no means pretend that we are not guilty, or rather that we are not liable to have similar opinions imputed to us. — *Cond.*

surely no one can contemplate such wonderful mechanism as is here laid bare before us, without being struck with astonishment. The spongioles and youngest parts of roots imbibe moisture from the soil, and are found to be rich in nitrogen, a gas, a supply of which is "indispensable to their healthy condition." Roots have not the power of refusing deleterious substances, and may be poisoned in the same manner as animals. In the growth of the stem, Dr. Lindley makes a nice distinction between the cellular tissue and woody fibres; the former being the only portion of a plant which grows laterally. He proposes, for the sake of simplicity, to call it the *horizontal system*; this latter, which increases by the addition of new tubes, he calls the *perpendicular system*. On the same principle he would confine the word hybridising to the admixture of species, and crossing or cross breeding, to that of varieties. A uniform adherence to this improvement in nomenclature is certainly desirable. Mr. Herbert suggested another improvement, bearing on this subject, which has been overlooked by Dr. Lindley and others, yet the present confusion in the naming of hybrid productions demands serious attention to it. Mr. Herbert says, "It would very much tend to preclude confusion, if all substantive genitive cases were abandoned to cultivators for the distinction of their varieties, and the names of all species confined to adjectives."*

* "Very great confusion is produced by the nurserymen giving a Latin name to every garden seedling, and men of science should set their faces decidedly against the practice, which M. DeCandolle very inauspiciously sanctioned with respect to hybrid plants. Where garden varieties are much multiplied, florist's names ought to be used, as with hyacinths, tulips, &c. Hybrid plants which are found of spontaneous growth in the wild abodes of their parents, should rank as species marked Hyb. Sp., or spontaneous hybrid; those of complicated or uncertain intermixtures in our gardens should be marked as Variety Garden Hybrid. It would very much tend to preclude confusion, if all substantive genitive cases were abandoned to cultivators for the distinction of their varieties, and the names of all species, and permanent local varieties, confined to adjectives. With this view I venture to alter all the proper names adopted in this order to an adjective form, writing *Caldasiana* for *Caldas*; and I earnestly press the convenience of this arrangement on the consideration of botanists, by which it may be understood at once that *B. Caldasiana* must be a species, or permanent local variety, and that *B. Caldas* would designate a seminal or hybrid variety; and, as it will be vain to urge nurserymen not to dignify their productions with Latin names, I wish to request them to confine themselves to genitive cases of proper names, names of romance or heathen deities, or of substances, as *flammæ* instead of *flammeus*, *eboris* instead of *eburneus*; and, if the botanical editors of popular periodical works will attend to this suggestion, we shall get rid of the overwhelming confusion which garden productions are creating. At present, in our best botanical catalogues, every seedling *Camellia japonica*, or *Hippeastrum*, is dignified with a Latin adjective name; and the endless garden intermixtures of *calceolarias* are named like the natives of South America, very much to the disadvantage of science. Cultivators will have an ample fund of names if all genitives are given up to them; and the change of the few genitives that have been used in the scientific

Nothing can be more simple than this; I would earnestly press it on the consideration of all those concerned. I hope you will attend to it in the next edition of the *Hort. Brit.*, and in this Magazine, as most of these great botanists are quite as tenacious of their antiquated lore as the lawyers. What, for instance, can be more absurd than the terms *inferior* and *superior* fruit, as applied by botanists? Yet if one were to supply proper terms for these, botanists would think the world was to be turned upside down!

But to return to our subject. Let us see how the sap is going up and down through all the ramifications of a young healthy tree. There is nothing in the unanimated creation more beautiful than this. Nothing so worthy the attention of the philosopher. The principle which guides it was not understood till very recently, and some people say we do not even now thoroughly understand it.

“It must have been remarked by all intelligent observers, that in the majority of works upon horticultural subjects, the numerous directions given in any particular ramification into which the art is susceptible of being divided are held together by no bond of union, and that there is no explanation of their connexion with general principles, by which alone the soundness of this or that rule of practice may be tested; the reader is therefore usually obliged to take the excellence of one mode of cultivation and the badness of another, upon the good faith of gardening authors, without being put into possession of any laws by which they may be judged of beforehand. Horticulture is, by these means, rendered a very complicated subject, so that none but practised gardeners can hope to pursue it successfully; and, like all empirical things, it is degraded into a code of peremptory precepts.”

Many of us old gardeners never could understand the circulation of the vegetable fluid till the appearance of the hot-water system, and here we had a complete solution of the theory at once. Wherever the fire-heat had most effect, which of course was at the bottom of the boiler, there circulation first commenced. It is just so in trees. The heat of the sun has most power on the tenderest parts of the tree, which are the tender points of the shoots, and there the sap first flows; in both cases the vacant space left by the circulation is immediately filled up by the next particles, and this goes on in beautiful harmony as long as the stimulus is applied. The leaves let off the lighter portion of the sap, as the cistern at the end of the pipes lets off the fine vapour of the water so essential to healthy vegetation. As the lighter portion of the sap escapes by the leaves, the rest gets more dense, and is returning back to form wood and all the other appendages of a tree; just as the water in the cistern gets denser by cooling, and returns to the boiler, leaving its sediment along the bottom pipe. The bottom of the boiler has no power, like the roots of a tree, to discharge the final sediment; and this

nomenclature into the form of an adjective, will produce no inconvenience.” (*Herb. Amaryl.*, p. 33.)

is the only difference between the two systems. But there is another, still closer, analogy between them. If you have a close boiler and elbow turns at the extremity of your pipes, there will be little or no sediment. Just so with a tree or branch. If you pull off the leaves as they are produced, the circulation keeps on as before; but you will have no formation of wood, buds, &c., for want of the proper *sediment*.*

The young reader must now turn to Dr. Lindley's way of explaining the circulation, and he will find the subject increasing in interest at every succeeding paragraph. Dr. Lindley is evidently at home here, and will be sure to detain you till he makes you understand the whole of this beautiful process, and every little thing about it which is likely to be of any use to you; if you never heard how flowers are formed, this part of the subject will be apt to electrify you. You will be astonished, too, to find how easy it is to learn all this yourself, and you will also wonder how he could find out all this; but these great botanists are always prying into the secrets of plants, and they have glasses that would make a little twig as big as a gate post. By these means they see things that you or I would never think of looking after.

I must now leave you with the doctor, while I see how he and the gardeners agree about hybridising. Here the angry critic might ask where and when was the theory of vegetable superfoetation "proved by the most satisfactory course of enquiry?" It was first believed in by Mr. Knight; at least he wrote a paper on it in one of the early volumes of the *Transactions of the Hort. Soc.* The subject of his experiments was the garden pea; an excellent plant as far as the safety of the experiments is concerned, but an indifferent one to draw conclusions from: had it not been for the shape of its flowers, guarding the style and stigma from the intrusion of foreign pollen, it would be as difficult to preserve its varieties true as those of the turnip. It is not in the nature of things that an original writer like Mr. Knight should be always right in his conclusions. I cannot say this part of his views is impossible to be proved; but I can safely say it is the next degree to it. I was smitten with this doctrine once, and, after a great many fruitless experiments for the last

* "A growing shoot, although divested of its leaves as soon as they are unfolded, will grow as fast, and increase as much in diameter, as another shoot with its leaves in full operation, other circumstances being the same; but, if you continue disleafing the second season, there will hardly be any addition to the diameter of the shoot. Disbudding in this manner the summer's shoots, as they proceed in growth, is the simplest mode I know of for reducing the strength of an over-luxuriant tree. As little or none of the sap taken up by such shoots is elaborated, it is entirely lost to the general secretion of the parent tree. By this method I have, in three years, reduced healthy vigorous young pear trees to the point of starvation." (*Gard. Mag.* for 1837, p. 203.)

twelve years, I am forced to this conclusion, but I am very glad the author lends the weight of his name in its favour.

“ We cannot reasonably doubt that a process so simple as that of dusting the stigma of one plant with the pollen of another, which must be continually happening in our gardens, either through the agency of insects or the currents in the air, and which, where it takes place between two varieties allied to each other, must necessarily produce a cross ; we cannot suppose, I say, that this occurs in our crowded gardens and orchards at that time only when we perform it artificially. The operation itself, although so simple, consisting in nothing more than applying the pollen of one plant to the stigma of another, nevertheless requires to be guarded by some precautions. In the first place, it is requisite that the flower whose stigma is to be fertilised, should be deprived of its own anthers before they burst, otherwise the stigma will be self-impregnated, and although superfœtation is not, by any means, impossible, yet it is not very likely to occur.”

This will be the means of turning the attention of many to the subject, and the result will be the final settlement of the question. If you think a short notice of my failures would be of any use, I can send you the particulars. [We shall be very glad to receive them. Hybridising and cross breeding are the manufacturing of the raw material for human use.]

In the practical portion of the work, or second book, Dr. Lindley shows his intimate acquaintance with our art, by his discrimination in selecting portions from the best authors in the *Hort. Trans.*, *Gard. Mag.*, and other sources, to prove the general principles of vegetable physiology. Every thing doubtful he leaves as an “ open question.” Many useful tables are introduced to prove how essential bottom heat is. The doctor is quite a gardener on this point, and he makes it appear that Mr. Knight was by no means against bottom heat ; and that “ the dispute about bottom heat was not as to the necessity of it, but as to the manner of obtaining it.”

The chapter on *atmosphèrical moisture and temperature* is exceedingly interesting. This is the least-understood portion of this part of the work : Daniell's instruments and writings, and Mr. Thompson's tables and observations, are here brought into full requisition. This chapter alone is worth the price of the book. Many of the old gardeners will not say much in favour of the next chapter, which is on ventilation. The three following chapters are on seed-sowing, seed-saving, and seed-packing, and are replete with useful information. The essence of the seed-packing chapter ought to be sent out to all residents in foreign climes who are in the habit of sending home seeds. Dr. Lindley had previously published the greatest portion of this chapter, and its details are well known and appreciated by scientific collectors. The five following chapters treat on the different modes of propagation. Propagation and amelioration are two indispensable points in a gardener's education. The scientific

bearings of all the modes of propagation are here comprehensively detailed, and cannot fail to be of the utmost use to all concerned. The next chapter treats on pruning, and must be studied attentively in connexion with that on transplanting. This subject has been more warmly discussed in this Magazine than any other. Dr. Lindley says, "With regard to pruning plants when transplanted, there can be no doubt that it is more frequently injurious than beneficial." This is substantially correct, and theoretically so. No pruning should take place at the time of transplanting; but here natural causes and accidental circumstances often conspire to place theory in the background. In that case, the next safest way will be to take the guidance of successful practice: this the author very sensibly allows. "The danger," he says, "to be feared is, that the perspiration of the leaves may be so great as to exhaust the system of its fluid contents faster than the roots can restore them, and in careless transplanting this may doubtless happen: in such cases it is certainly requisite that some part of the branches should be pruned away." To convey the stigma of *careless transplanting* in a less offensive shape, the author might just as well have added, *and dry climate*, which has fully as much of the blame. The success of Sir Henry Steuart was certainly owing to the moist climate of the South-west of Scotland, as you have already shown somewhere in this Magazine. No one can say Sir Henry was a careless planter, and no one knew better the scientific principles which ought to guide the successful planter; yet, with all these advantages, and his moist climate in addition, he had as many failures in transplanting as nine tenths of our intelligent gardeners. Although Sir Henry had *theory* on his side, our author thought best to take the experience of successful practice for his test. Mr. M'Nab's treatise on transplanting is held up throughout this part of the work as the surest guide to the planter. This, of itself, would prove the integrity of our author's intentions. A treatise from Mr. M'Nab's pen, on any department of gardening, would be worth all that the whole race of Scotch lairds and baronets could write on the subject till doomsday.

I really must apologise for occupying so much of your space, and yet there are many more chapters to look over; that on the improvement of races I may again refer to, and the last one, which is on soil and manures, will repay an attentive perusal.—*D. B.*

Kingsbury Gardens, Feb. 7. 1840.

ART. II. *Vegetable Organography; or an analytical Description of the Organs of Plants.* By M. A. P. DeCandolle. Translated by Boughton Kingdon. Forming 2 vols. 8vo, with numerous plates. Part XI. and last.

WE have strongly recommended this work from time to time, and we have now to congratulate Mr. Kingdon on having brought it to a conclusion. The instruction and pleasure which he must have experienced in translating it will be an ample compensation to him in one sense; and we hope the book which he has produced will also be successful in a business point of view. Whether it is so or not, the public are greatly indebted to Mr. Kingdon for the courage he has shown in undertaking the translation, and the able and judicious manner in which it is executed. Of the merit of the work itself, it would be superfluous to speak. The extensive views and enlightened generalisations of the author meet the eye in every page, and carry us along in such a manner, that no person taking up the book would wish, if possible, to lay it down till he had read it through. What is delightful in this, and in all M. DeCandolle's other works, is, that, while he is developing new and original views, and pointing out in what these views differ from those of preceding botanists, he never once deviates in the slightest degree from an exalted tone of liberality and good feeling. No opinions held by others are condemned as absurd, or wondered at for their inaccuracy; but all are treated with the same philosophical spirit as if they were merely so many appearances or phenomena in plants or animals. How different this moral spirit from that of some botanical authors, living and dead!

As a specimen of the work, we wish we could quote the chapter on vegetable symmetry, but it is too long, and we therefore give the last chapter of the second volume, which contains a

GENERAL SUMMARY OF THE STRUCTURE OF PLANTS.

"1st. A plant is an organised and living being, devoid of voluntary motion, having neither nerves, muscles, nor a central cavity resembling a stomach, and always, or nearly always, attached to the soil from which it draws its nourishment.

"2d. Plants are either wholly, or in a great measure, composed of membranous Cellules, closed on all sides, more or less united together, and enclosed, at least in their young state, in a membranous cuticle. Those which are entirely thus formed bear the name of Cellular Plants.

"3d. Those which are thus formed in part, and which are called Vascular Plants, present, besides the cellules, cylindrical tubes which are called Vessels; these are never naked, but always surrounded by cellules.

"4th. In vascular plants we observe moreover: — 1st, that the cellules and vessels are united in very different degrees, so as frequently to leave between them empty spaces, called Intercellular Passages; 2d, that besides the purely membranous vessels, there are bodies rolled spirally, and endowed with great elasticity, which are called Tracheæ; 3d, that their cuticle is pierced (at least in almost every part exposed to the air) with pores or Stomata, which appear to be evaporating organs.

" 5th. The cellules are endowed with the faculty of uniting together, of absorbing the moisture around them, and probably of contracting and dilating. They are round, or more or less elongated; the former enclose the feculent, mucilaginous, or resinous matters which they have elaborated, of which the latter contain little or none. The round ones form the parenchyma; the long ones (by themselves in cellular plants, united with the vessels in vascular ones,) compose the fibres or nerves.

" 6th. The passages between the elongated cellules, or the vessels, appear eminently to serve for carrying the lymph, i. e. the as yet unelaborated watery juices. Those which are formed among the round cellules contain the more stagnant juices.

" 7th. The vessels, whatever their form, seem eminently intended to contain air or gas, and are true aerial canals, at least in the ordinary course of vegetation.

" 8th. Certain particular points of the surface of plants, and especially of vascular ones, are more eminently endowed with the faculty of absorbing water. They are called Spongioles, and are situated at the extremity of roots, at the top of the style, and on the surface of seeds.

" 9th. Dilatations of the intercellular passages, or, in certain cases, ruptures of the cellules, cause irregular cavities in the interior of the tissue. These receive the name of Air Cavities when filled with air, or of Receptacles of proper Juice when they contain an elaborated juice.

" 10th. Glands or glandular surfaces are some of them composed only of cellular tissue, others of cellular tissue and vessels; both secrete special juices, but the first appear (at least in certain floral organs) to be excrementitial, and the second recrementitial.

" 11th. The surface of plants exposed to the air is often invested with Hairs, which are prolongations formed of projecting cellules. Some of these hairs are protecting organs for the surfaces; the others the supports or canals of excrementitial glands. They are always situated upon the nerves, whilst the stomata are always upon the parenchyma.

" 12th. A vascular plant, considered lengthways, is composed of two bodies opposed by their bases (stem and root), and which grow in a contrary direction to one another. Their point of junction is called the Neck.

" 13th. The body which descends, or the Root, elongates indefinitely by its extremity alone; does not become green by the action of the sun, except at its extremity; bears neither leaves nor flowers, and serves to fix the plant in the ground, and to draw up its nourishment.

" 14th. The body which rises upwards, or the Stem, elongates throughout its whole length till the period when it ceases to grow, unless by the development of a body resembling itself (branch), and which is grafted upon it. It becomes green on exposure to the light throughout its whole length, at least in its young state, bears leaves and flowers, and transmits to them the nutriment absorbed by the roots.

" 15th. The stem of vascular plants is sometimes cylindrical, composed of a single system (the Woody Body), which increases by the development of new fibres internally; sometimes conical and composed of two systems (the Woody Body and Bark), which increase in diameter by means of layers, which are developed upon the surface of each of these systems which is in contact with the other system. To the first the name of Endogens is given, to the latter that of Exogens. The structure of the root of each class is similar to that of the stem.

" 16th. The stem of vascular plants is furnished laterally with appendicular organs, which seem formed by the expansion of one or more fibres.

" 17th. These appendicular organs, although very different from one another in their appearances and uses, seem, however, entirely identical in their original nature.

" Those which are already formed in the embryo, bear the name of Cotyledons or Seed-leaves; those which are produced immediately afterwards,

Primordial Leaves. The following bear simply the name of Leaves. Those which immediately surround the flower receive the name of Bracts, and the flower itself is composed of several verticils of appendicular organs, much modified.

“18th. The appendicular organs perform, according to their position and mode of development, several different functions, of which the principal are :—

“1st, That of nourishing organs, as the cotyledons and leaves ;

“2d, That of protecting organs, as the scales of buds, bracts, sepals, petals, carpels in their last stage ;

“3d, That of fructifying organs, as the stamens, and the carpels, during the first stage of their existence. Several partake of both of these functions.

“19th. The nourishing appendicular organs are, at their origin, alternate in endogenous plants, called also, for this reason, Monocotyledons ; opposite or verticillate in Exogens, called also Dicotyledons. In the course of their development, those of Endogens always remain alternate or spiral, those of Exogens may either remain in their primitive state, or take a spiral disposition.

“20th. The appendicular organs which compose the flowers are, in both classes, disposed in concentric verticils ; the innermost are sometimes spiral.

“21st. The protecting appendicular organs hold a middle station, in form, size, colour, and often also in position, between the two other classes ; and we frequently see them metamorphosed, either into organs decidedly nourishing, or more rarely into fructifying ones.

“22d. The appendicular organs are generally composed of a petiole and limb, but one of them may be wanting. The Petiole, which is the bundle of fibres not as yet disunited, has its fibres longitudinal ; the Limb, which is the part formed by the expansion of the fibres, has them more or less diverging. These fibres of the limb, or Nerves of leaves, are generally curved in Endogens, and separate at angles more or less acute in Exogens.

“23d. The nerves of curvi-nerved leaves converge towards the apex, or diverge from a middle bundle. Those of anguli-nerved ones are pinnate, palmate, or pedate ; but the portions of the limb of the three last classes are penni-nerved, so that this form seems essential to the leaves of Dicotyledons.

“24th. The leaves of Dicotyledons are the only ones which have been seen, either composed of joints or leaflets, or furnished with lateral stipules.

“25th. Germs, or the undeveloped rudiments of new individuals, appear able to arise from all parts of the surface ; but there are certain points where they are developed in preference, such as the axils of the appendicular organs, and the extremities of the fibres of their limbs.

“26th. The germs which are placed in the axils of the appendicular organs, along the stem or petiole, may be developed by the action of the nutritive forces alone. Those which are situated at the extremity of the lateral fibres of the limb, almost always require (except in Briophyllum), in order to be developed, a particular operation called Fecundation.

“27th. The germs which are developed without fecundation most frequently arise united to the mother plant without having proper envelopes, and without shooting out roots : they then form branches. Some separate when they are furnished with a tubercule or store of nutriment : they then form separate individuals, and produce roots.

“28th. Every stem or branch can shoot out adventitious roots. In Dicotyledonous trees, these spring from the lenticels ; every branch, furnished with them, or capable of producing them, may easily be separated from the mother plant, and form a distinct being.

“29th. The germs which are developed by fecundation are always contained in a closed envelope, furnished with the rudiments of a root and appendicular organs. They receive the name of Embryos.

“30th. The unfecundated germs perpetuate the varieties of the mother plant ; the embryos only retain the characters of races or species.

“31st. The appendicular organs which immediately surround the flowers,

or the bracts, hardly ever have leaf-buds developed in their axils ; this is still more seldom the case in the appendicular organs which compose the flowers.

“ 32d. The buds, or germs, which are developed into branches, are often protected in their young state by scales, which are nothing but the outermost appendicular organs of the young branch, modified by their position.

“ 33d. The flower, in which is the apparatus destined for the fecundation, is a kind of terminal bud, formed of verticillate appendicular organs, the outermost of which act the part of protecting organs, the innermost of sexual ones ; but they are capable of changing their office, by being transformed either into leaves, or from one into another.

“ 34th. In the modifications or transformations of the appendicular organs, each is only usually converted into the nature of the verticil which follows or precedes it in the order of developement or position. The first phenomenon, which is the most frequent, has received the name of Ascending, or Direct, Metamorphosis, and the second, that of Descending, or Retrograde, Metamorphosis.

“ 35th. The flower, being formed of verticillate organs, is necessarily terminal with regard to the pedicel, at least when the pedicel is not prolonged beyond it, as happens accidentally in certain prolific flowers.

“ 36th. Pedicels near one another, and composing the same inflorescence, are disposed after three systems : — 1st, the outer or lateral ones are developed first, and the flowering proceeds indefinitely in a centripetal order ; 2d, the central one, which is necessarily terminal, flowers first, and the flowering proceeds in a centrifugal order ; 3d, these two laws are combined, the one affecting the general axis, the other the lateral branches.

“ 37th. The number of verticils in phanerogamous flowers is usually four ; but it may vary, being either less when one is absent or united to the neighbouring one, or more when one is composed of several verticils or similar rows.

“ 38th. The almost universal disposition of the pieces of each verticil or row, is that of being alternate with those of the preceding verticil or row.

“ 39th. The number of pieces of each floral verticil is generally three in Monocotyledons, and five in Dicotyledons.

“ 40th. All the caulinary, and especially the appendicular, parts of plants are capable of being united together, especially during their infancy ; the union is a distinct phenomenon from the graft ; it is the more easy in proportion as the nature of the organs is more analogous ; it takes the name of Cohesion when it comes between similar organs, and Adhesion when they are different. The different degrees of adhesion of similar organs, or of the parts of the same organ, determine either its integrity, or the divisions or indentations of most organs.

“ 41st. All the caulinary or appendicular parts are capable, when they are filiform, of expanding into limbs ; and, when naturally in the form of a limb, of presenting a cylindrical appearance. They may also, within certain limits, put on forms, sizes, texture, colours, and even functions and positions, varying in different points of the same individual or analogous ones ; this constitutes the Degenerations or metamorphoses of organs.

“ 42d. All the appendicular organs, verticillate or spiral, are capable of presenting multiplications of number, both in the increase in the number of the verticils or spires, or in the increase in that number of the pieces in each of the systems.

“ 43d. All the organs of plants are susceptible of being abortive, either wholly or in part, and, consequently, of presenting simple rudiments, or leaving empty spaces.

“ 44th. All the irregularities observed in the symmetry of verticillate organs, and especially in that of flowers and fruits, appear to result from one of the causes mentioned in the four preceding paragraphs, or from the combination of several of them.

“ 45th. In particular, the unity or solitariness of the verticillate organs can

only exist by the abortion of those which ought to complete the verticil, or spire, or by the union of several.

"46th. The fruit is formed by the Carpels, which may be free, or cohere together, or adhere to neighbouring parts.

"47th. As the two margins of each carpellary leaf can bear ovules, the solitariness of the seed in a carpel, free or united to others, can only result from an abortion.

"48th. The embryo must be considered as the developement, by fecundation, of a germ situated at the extremity of one of the lateral fibres of the carpellary leaf.

"49th. Cryptogamous plants present, in their organisation, only partial indications of symmetry, which, in the present state of the science, are not sufficient to enable us to recognise the laws. We cannot affirm, particularly, whether there is fecundation in all Cryptogamous plants, or whether several are not reproduced by unfecundated germs."

ART. III. *Icones Plantarum; or, Figures, with brief descriptive Characters and Remarks, of new or rare Plants selected from the Author's Herbarium.* By Sir William Jackson Hooker, K.H., LL.D., &c. Part VI. 8vo, 48 plates. London, 1840.

WE hail, with much satisfaction, the continuation of a work that is likely to add so much to our botanical information, and thank the author for his liberality in opening to us the treasures of his unrivalled herbarium; making us not only acquainted with the more rare and curious plants, but, by exhibiting some of the most showy of these novelties, exciting in all naturalists and amateurs a desire of adding them to their collections. The plates, which are numerous, are got up in a very superior style; and the accuracy of the botanical details cannot for a moment be doubted. Those which will probably prove hardy ligneous species are but two: viz. 1. *Ceanòthus papillòsus* *Tor. et Gr.*, a native of California; "a very distinct and well-marked species, with blue flowers, abounding in resinous exudations, which emit a fragrant smell;" and which will, no doubt, when introduced, be a formidable rival to the much admired *Ceanòthus azùreus*. 2. *Amýgdalus glandulòsa*, a native of Texas, and remarkable for its "very downy foliage and calyx," and for "the glands which terminate every one of the serratures in the obtuse apex to the leaves." The great value of the *Amygdàleæ* in our gardens will repay all the trouble incurred in introducing new and distinct species, decking, as they do, the path of spring with lovely and cheerful blossoms.

The other ligneous species described are about nine; many of which will, no doubt, in a few years, lend their aid to beautify our green-houses and conservative walls. One of the handsomest is *Hibbértia virgàta*; a small shrub, "with the branches attenuate and virgate, densely clothed with fascicles of leaves, not inaptly resembling those of the larch. The flowers large and

handsome, yellow, nestled, as it were, among the leaves." This plant, when introduced, will form a good companion to *Candollea Cunninghami*. *Tetracarpæa tasmannica*, a new and very beautiful little cunoniaceous shrub, found near the source of the Meander, or Western River, in Van Diemen's Land. Three closely allied species of *Bæckia* are described, which, we have no doubt, would stand well on a conservative wall; and *Vaccinium Imrayi*, from the mountains of Dominica. This plant, Dr. Hooker says, "is one of the most remarkable species of the genus with which I am acquainted. Of the present plant, the firm coriaceous leaves are, in one specimen in my possession, 5 in. long; but the most remarkable feature in the plant is its extremely thick corollas, so thick and firm that they are difficult to dissect, even with a very sharp knife." We hope soon to see these plants introduced to our gardens. The other plants figured are all herbaceous. Among the more remarkable are: *Lawrência spicata*, from Van Diemen's Land, belonging to the natural order *Malvaceæ*, but very different from any plant of that order we ever saw. Dr. Hooker says, "I am quite unable to point out any genus of the order to which it is here referred, with which in habit it has any close affinity." *Moróstachys capitata*, a most remarkable Brazilian grass, which "attains to a considerable height, climbing among, and supporting itself on, the branches of the shrubs among which it grows." *Rubus Gunnianus*, a small bramble which belongs to the same group with *R. árticus*. Mr. Gunn says, "From its growing where snow covers the ground a considerable part of the winter, and where the climate is at all seasons very cold, I think it would succeed well in your country, and be an agreeable addition to your list of esculent fruits." Many of the other plants figured and described would prove valuable additions to our flower-borders during the summer, treated as annuals: and some few might even stand our winters among the herbaceous plants. We can but thank Sir W. J. Hooker for the clearness and accuracy of his descriptions and figures, and, for the sake of those who take in the work, notice a slight error that has taken place in numbering the plates. No. 275., *Trifolium macrócalyx*, ought to be No. 285.; and be placed as such. This is a small error, easily set right when the work is bound up. A caryophyllaceous plant is also wrongly numbered. — *W. A. M.*

ART. IV. *A History of British Ferns.* By Edward Newman, F.L.S. 8vo, pp. 104, numerous woodcuts. London, 1840.

THIS is a book that must be acceptable, both to the botanist and amateur, for its extreme accuracy, and for the great care

that Mr. Newman has taken in figuring and describing the varieties of many of the species from his own observation; for, not content with seeing them in a natural state, the author has transplanted them to his own garden, and noted them in all their changes. The author, having stated very clearly his method of cultivating the different species, says: "I have pressed fronds from the same root for three successive years, and have found variations abundantly adequate to the establishment of species quite as distinct as many of those in the *English Flora*; and I consider all that cultivation, as I have explained it, can accomplish for any plant is, to hasten or delay those changes to which that plant is by nature liable; it cannot increase or diminish the number of actual species." We fully concur in this remark; and only add, that, had this been attended to before, there could not have been so much confusion among the species of ferns as there has hitherto been. The author also says (p. 3.) that, "henceforward, in the veins of a new fern will be sought the characters which shall decide its genus." This is one of the best modes possible for determining genera, and we hope, with Mr. Newman, that it will soon become general; affording, as it does, a method of making out the genus of a barren frond, which is not always easily done; and will, no doubt, throw much light on fossil ferns, where the fructification is often so much injured as frequently to be useless. The descriptions are very full, and with as little technicality as possible, which renders it a valuable present to the lady botanist. A good number of localities are given for each species, which will give collectors an opportunity of getting specimens from the different places mentioned, many of them varying exceedingly in different localities, and thus determining still further whether they ought to rank as species or varieties. The illustrations are very accurate and original, being all taken from nature, and drawn on the wood by the author. In short, the illustrations are so clear, and the descriptions so correct, that no persons studying the vegetable productions of Britain should be without this book. The cultivator will find it available for the numerous excellent remarks on the culture of ferns, raising them from seeds, or growing them on Mr. Ward's system; and, as a fernery is a desideratum in all good gardens, no gardener ought to be without it. — *W. A. M.*

ART. V. *The Journal of the English Agricultural Society.* Part III.
8vo, plates and woodcuts. London, 1840.

IT is clear, from this publication, that the landed proprietors of England are at last determined to make the most of their
1840. MARCH. N

estates, by the only way in which this can be done, viz. by improving the agriculture practised on them. There are some excellent articles in the present part; and perhaps the most valuable is one by Philip Pusey, Esq., M.P., entitled *Experimental Inquiry on Draught in Ploughing*. Our countrymen in the North will be not a little astonished to find that there is a plough, of English origin and construction, and with one wheel (!), which is easier drawn, and makes a better furrow than the most improved form of Scotch ploughs sent out by Messrs. Drummond of Stirling, in the proportion: trial 1., of 14 to 19½; trial 2., of 43 to 51: trial 3., of 11 to 17½; and trial 4., of 23 to 34. The implement is called Hart's improved Berks One-wheeled Plough. We cannot spare room to go into details, but we most strongly recommend the article to all Scotch farmers and bailiffs. The great fault of us Scotchmen is, our strong prejudices in favour of whoever or whatever is Scotch; so general and powerful are these prejudices, that, when a Scotch bailiff or farmer first comes to England, he generally finds nothing good there in the way of agriculture, but what corresponds with what he has seen in Scotland; making no allowance for difference of climate and other circumstances. We do not say that there are not many exceptions among the more enlightened Scotch bailiffs and stewards; we merely assert that this is the general feeling. Nothing will tend so much to obliterate every prejudice of this kind, as English proprietors taking up the subject of agriculture, and experimenting and thinking for themselves. How incomparably more rational, useful, and honourable, to be occupied, as Mr. Pusey has been, in superintending experiments, and afterwards giving an account of them and reasoning on them, than in fox-hunting or shooting; mere relics of the occupations of barbarous times, and which, with the progress of society, will as completely disappear from the catalogue of gentlemanly amusements, as bear-beating, badger-drawing, and the other brutalities which once held place amongst them!

The part of the *Journal* now before us is by far the best that has yet appeared; containing, as it does, a number of papers, scientific, experimental, and practical. We cannot help recommending the articles on subsoil-ploughing, and on thorough-draining, though the subject occupied a considerable part of the preceding number. One excellent feature in this *Journal* is, that there is not a single paper in it, nor even a foot-note, that has not the authority of a real name appended.

ART. VI. *The Surveyor, Engineer, and Architect; or, London Monthly Journal of the Physical and Practical Sciences.* By a Committee of Practical Surveyors, Engineers, and Architects, of much Experience, and in active Employment. Robert Mudie, Literary Conductor. No. I. 4to, pp. 24, one steel engraving, and some woodcuts. London, 1840.

THE preliminary address enlarges on the influence which the surveyor and the engineer have had in promoting civilisation, by exploring new countries, by planning and executing improvements upon the great scale, with knowledge of all the circumstances, and for national objects. Such objects, and such means brought to the execution of them in the best, the most useful, the most elegant, the most durable, and, at the same time, the cheapest manner, form the joint province of surveyors, engineers, and architects; but it is not always possible, neither is it necessary, though it were possible, to draw the lines of demarcation between them, and assign to each his department.

The following principle, which next occurs, deserves the especial attention of the gardener, and on it is founded our practice of occasionally introducing subjects not directly horticultural:—

“In so far as manual operations are concerned, there must be a division of labour in those higher branches of art, as well as in branches which are more humble; but the division of labour is one thing, and a good; while the division of knowledge and thought is another thing, and an evil.” (p. 3.)

The first article is on the Reform Club-House, of the front elevation of which there is a very handsome steel engraving. Some of the critical remarks given under this article are good; but others are, as we think, in bad taste. We give first an example of the latter:—

“The Union [club-house] is at once poor, patched up, and tawdry, entirely out of keeping, being plain even to meanness in some respects, finical in others. The United Service has so far more consistency, in as much as its architecture is very poor throughout. It may be called Italian, because it cannot be described as being of any other style; but, then, it is Italian in the last stage of consumption: the style is thoroughly impoverished and enfeebled; and its spirit and gusto are there quite evaporated.” (p. 6.) And, again:—

“Take care to roast the ends of your pig well,” says the cookery book, “and the middle will roast itself;” so, too, in architecture, be careful to study diligently all those points, whether of minutiae or not, which others are in the habit of overlooking, because you cannot very well, through sheer heedlessness, neglect what you are aware the merest novice in the art instantly directs his attention to. As it appears to us, it is in following such maxims, that the secret of Mr. Barry’s generally acknowledged superiority in great measure lies; not entirely, because there must be the feeling for art, which stimulates to that industry, in which all the faculties are cheerfully devoted to the task; and industry of this nobler kind, be it observed, is very different from plodding diligence, which, satisfied with doing the ‘passably well,’ is unambitious of the ‘better.’” (p. 6.)

On the other hand, the following passage is an example of judicious criticism, and such as, unlike our first quotation, will be understood both by the general reader and the architect. Comparing the Reform Club-House with Whitehall, the critic says: “Though both are Italian in style, they belong to very different schools, and are designed upon very different principles. In the one, the introduction of two moderate-sized orders occasions what ought to be principal, namely, the columns and entablatures, to appear rather insignificant, both in relation to the space over which they are scattered, and the windows likewise; while as decorative accessories they are too much, as essential parts of the structure they are not enough. In proportion to the entire mass, the upper entablature looks puny and inefficient; well enough adapted to that particular division of the elevation, but not to the

whole. Altogether, such an application of the orders, to say nothing of the defects of detail, produces a dryness and littleness of manner, precisely the reverse of the character of classical architecture. In this new club-house by Mr. Barry, on the contrary, and the remark applies also to his former one, instead of the composition being cut up into distinct divisions, finishing and then commencing again, it is made to form one consistent ensemble, crowned by a magnificent cornice, proportioned, not to a part, but to the whole; while sufficient decoration, in other respects, is derived from essential features and members, windows, string-courses, &c., which are allowed to display themselves with a boldness and effect hardly attainable where windows are introduced between straggling columns, the result generally being, that the design looks rather confused and crowded up than rich. Here we perceive both richness and simplicity: the windows are very properly treated as indispensable features, not as indifferent ones, or what it would be desirable, if possible, to get rid of, but as important in the design, equally necessary in themselves, and valuable as regards decoration. Neither do we here meet with that very offensive disparity of character in regard to them, which is frequently allowed to take place, where no consistency of style is kept up between the windows on different floors, but the lower ones are positively mean and poor, in comparison with the others; not only without dressings or architraves, but without that degree of finish they are susceptible of as apertures in a basement, whether that part of the elevation be rusticated or plain." (p. 7.)

The remaining articles are: on Architectural Competitions; Stove for the new Houses of Parliament; Pressure of Earth against sustaining Walls; projected Tunnel through the Alps; Branch Railroads; Remarks on measuring the Angle subtended between two Base Lines; great Care necessary in building Arches; the Oscillating Steam-engine; Mr. Telford's Scale of Proportions for Bridges on the Highland Roads; Suspension Railway; Lock-Gates of the Thames and Medway; Canal at Rochester, by Mr. Collier; the Coal Fields of Belgium; French Academy of Sciences; Navigation of the Medina; the Maidenhead Bridge on the Great Western Railway; Adam's Patent Railway Carriage; New Soldering Apparatus; the recent Land Slip in Dorsetshire; Railway Intelligence; Miscellaneous Facts and Remarks; and List of Patents granted during January.

The tunnel through the Alps is projected by M. Volta, an engineer of talent and experience. It is to pass through the Splügen, and the time estimated for its completion is 30 years. Possibly an open cutting might be completed in less time; because the two sides of the mountain might be formed into two inclined plains for a certain width, and thus thousands of men set to work instead of hundreds; but the expense would be greater, and the road would require to be arched over after all, to prevent its being choked up by snow. The Splügen once penetrated by a tunnel, the practice will, doubtless, be imitated in other parts of the world, from which advantages in the way of intercommunication will occur, the bare contemplation of which is sublime. How much better for nations to incur immense debts in this way, than in wars of aggrandisement! "Half the expense of one of the great battles which were fought during the late war, for objects of small importance, as compared with the Splügen tunnel, would complete the works, and leave for those who promoted them a far more noble monument, than ever was obtained by even the most illustrious of warriors." (p. 13.)

MISCELLANEOUS INTELLIGENCE.

ART. I. *Domestic Notices.*

ENGLAND.

CEDAR of Lebanon, its Varieties. — In walking through the park at Garnstone, a few days since, I was much struck with the great variety of character

observable in a grove of the *Cèdrus Libani*. In some individuals the young branches spread out more or less horizontally, while in others the head assumes a compact and almost a cone-like form ; they likewise vary greatly in tint, some being of a dead cypress-like hue, and others of a much brighter shade. Some of the trees, also, grow much more freely than others in the same soil and situation. — *J. B. W.* Jan. 14. 1840.

Rhizomórpha subterrànea Pers. (*Encyc. of Plants*, p. 1038.) — A very singular and rare fungus was lately found in a well in Back Street, Hertford, attached to the under surface of an oaken slab. Some account of it was given us by our esteemed Hertford correspondent, Mr. Wilds, and we have since seen the specimen on Dr. Lindley's table, at the Horticultural Society's Rooms. The most remarkable circumstance attending this fungus is, its strong resemblance in external appearance to ordinary roots, and by which all the species of these interesting plants are peculiarly characterised ; a resemblance so strong, that some botanists have described many of them as being merely the deformed roots of flowering plants. The analogy, however, is very superficial, for, on a careful observation, it is evident from their peculiar mode of ramification, from their occasional anastomosis, and, lastly, from the absence of spongioles at their extremities, that the branches of these very curious plants have no very close resemblance to roots ; and, on a more minute investigation, it is found that these root-shaped ramifications possess a structure differing essentially from that of the roots of both exogenous and endogenous plants ; that they contain no woody fibre, nor any of the modifications of vasiform tissue, so invariably present in each individual of these two great classes of the vegetable kingdom ; but that they consist entirely of cellular tissue, elongated into extremely fine filaments in the white elastic axis, but of a coarser and more condensed character in the dark brown inelastic and fragile integument.

Like others of the fungaceous tribes, the plants belonging to this genus increase by the addition of new filamentous tissue deposited in their interior, and the function of reproduction is accomplished by means of sporules developed at irregular intervals (not in indefinite situations or thalli, as in lichens, &c.) in this internal filamentous tissue, the sporules being ultimately emitted in vast numbers by the rupture of the integument by which the stems are surrounded. The situations in which such dehiscences have occurred, in the specimen just discovered, appear to be indicated by the presence of numerous small tufts of brownish filaments attached to the external surface of the main stem of the plant. Like many of the fungi, the rhizomorphas affix themselves to organic matters undergoing decomposition, rather than to organised beings in a living state : moreover, they generally vegetate in a pendent position, in moist and cool situations, and shunning assiduously the action of the solar rays ; hence, in dark mines, in wells, in clefts of rocks, &c., or in the hollow trunks of decaying trees, especially those of the willow tribe. This genus is farther remarkable for the luminous properties possessed by, perhaps, all its included species ; many of them emit a phosphorescent light of great intensity, sufficiently powerful to enable a person to read or write ; and, in one instance recorded by Nees von Esenbeck, this property was observed to be retained, in a specimen kept in a bottle, for nine days after its separation from its natural attachments. It may be remarked, that no luminosity has been observed in the specimen which has occasioned these remarks ; but it should be stated that none was sought for till seven days after its discovery. By far the greater number of these plants, hitherto known to us, have been discovered on the Continent, in the mines of Sweden and Germany ; indeed, it has even been stated that they are never found in England. Some of the species attain a length of many hundred feet, and vegetate so luxuriantly, that the roofs, walls, and pillars of the mines in which they are found are entirely covered with their branches ; the brilliant light which they emit, often dazzling and enchanting the beholder, converting the dark and gloomy aspect of those subterranean passages into a splendid scene of grandeur and magni-

fiſcence. From the anatomical and physiological characters of theſe various ſpecies of Rhizomórpha, it is evident that Linnæus was perfectly juſtified in placing them amongſt the cryptogamous, or flowerleſs, plants; a diviſion correſponding nearly to the Cellulares, or Acrogens, of natural ſystems: but the exact poſition which this genus ought to occupy in the ſcale has been a fertile ſubject of diſpute; in illuſtration of it may be mentioned, that Rhizomórpha ſubterrænea itſelf was placed by Linnæus among the lichens, and designated *Lichen radiciformis*. And although theſe curious and highly intereſting productions of vegetable creation have, by ſucceeding botaniſts, been elevated to the rank of a diſtinct genus, ſtill their precise relations of affinity to other genera of cellular plants have not been ſatisfactorily aſcertained, even at the preſent day.

The ſpecimen alluded to in the foregoing obſervations has been preſented by Mr. R. R. Shillitoe, of University College, London, to Dr. Lindley, Profeſſor of Botany in that College; to the botanical muſeum of which eſta bliſhment it will, from its extreme rarity, form a moſt deſirable and valuable acquisition. (*Hertford Reformer*, Oct. 19. 1839.)

State of Knowledge of the Middling Classes, in a Village in Suffolk.—You can hardly ſuppoſe how ignorant ſome of them are of everything beyond the pre-cincts of the village. I have induced a few to belong to a Friendly Society, inſtead of the uſual pot- houſe club, and I mean that they ſhould come to the Rectory once a quarter, and ſpend a quiet evening with me, when I propoſe to teach them draughts and cheſs, two games they had never heard of. I think that by teaching a few, I form ſo many centres of inſtruction by which others pick up a little. Now that I am become a conſtant reſident, I propoſe confining my lectures to once per month, at leaſt to one ſubject per month, for I ſhall occaſionally have to repeat them. Next Tueſday my ſubject is “Quartz and Glaſs.”—*J. Sept.*, 1839.

ART. II. *Royal Caledonian Horticultural Society.*

THE Winter General Meeting of this Society was held on Thuſday the 5th December, 1839.

The ſecretary, Dr. Neill, ſtated that ſeveral intereſting communications had of late been made to the Society; and, in particular, he read a portion of a horticultural tour, made by Mr. M'Nab, the ſuperintendant of the garden, during the month of October laſt; a letter from Mr. Anderson, Maryfield, on ſtriking cuttings while ſtill attached to the live plant, by partially dividing the ſtem and ſurrounding it with damp hypnum-moſs; a deſcription of a new epiphyte pot, a ſpecimen of the pot, containing a fine plant of *Stanhopea inſignis*, being placed on the table; and a letter from M. Réué Langelier of the Clarendon Nurseries, Jerſey; with a report by Mr. M'Nab, relative to a ſplendid collection of pears ſent to the meeting by that eminent nurſeryman. This was an important communication. It appears that about twenty of the kinds were previously in the Society's Garden, but at leaſt a dozen were new to it. Of theſe novelties, grafts will ſoon be procured, they having been proffered by the liberal cultivator. The new pear called Van Mons Leo le Clerc was found to be melting, and of muſky flavour. Some of the ſtewing pears were of uncommon ſize; a ſpecimen of the Double-fleur weighing 1 lb. 4 oz.; and a Cadillac 1 lb. 1 oz. It is remarkable, however, that, among the deſſert pears, the Duchesse d'Angoulême, from Hope-toun Garden, was conſiderably larger than that from Jerſey, although the latter was more mellow and of richer flavour.

The ſhow of Scottiſh pears and apples on this occaſion was not extenſive, but the ſpecimens were in general excellent. The chryſanthemums were alſo good; but the greateſt diſplay was in the article celery, the cultivation and

blanching of which are evidently carried to the highest perfection by our gardeners.

Several extra articles were produced at this meeting, for which the thanks of the Society were voted; in particular, a fine cluster of the *Dacca* plantain, produced at the Royal Botanic Garden, under the management of Mr. William M'Nab; a small but very pretty seedling apple, raised by Mr. Archibald Gorrie, and to be called *Annat Scarlet*; a seedling camellia, with flowers of a large size, raised by Mr. John Christie, gardener to Miss Gilchrist, Sunny-side, &c. — *P. N. Edinburgh, Dec. 1839.*

ART. III. *The West London Gardeners' Association for mutual Instruction.*

OCTOBER 28. 1839. — This evening, Mr. Judd read his paper "*On the Culture of Vines in Pots.*" At the autumn pruning of vines in houses, shoots of well-ripened wood, perfectly firm, with prominent buds, to be selected, and placed in large pots of sand, protected from the frost until the month of February, when the eyes are to be cut out, with a small portion of the wood, in the same way as the rose, before taking the wood from the bark, and inserted separately into 60-sized pots, for the purpose of making plants to fruit the following year. The reason of placing each singly in a 60-sized pot is, to prevent any check from shifting them from one pot to another. As good fruit depends much upon the perfecting of the wood, it is of the utmost importance that the growth be not retarded, which must be the case if more than one eye is placed in each pot; being divided when shifted, the roots are likely to be broken, and their growth much retarded until new spongelets are produced. When the eyes are potted off and well watered, they are to be placed in a frame on dung heat with a temperature varying from 65° to 70° Fahr.; kept close until they begin to push through the soil, when air is to be admitted by degrees, watering the roots and overhead when necessary, until the pots are filled with roots; then potted into larger-sized pots to keep them growing, and on no account to stop the leading shoot; being so luxuriant they will burst some of the main eyes which are to produce fruit the following season. All laterals and tendrils to be removed as soon as they appear. The plants the next time of shifting, which is to be done before the roots are allowed to get matted, should be removed to a vinery or stove with a temperature of 70° or 75°; trained up the trellis under the lights, or on the back wall, there to remain until the wood is perfectly matured; air being gradually admitted, to prepare them for their next situation. It is the practice with many gardeners to place their vines in the open air, or to take the lights off their houses to mature the wood; but he would always prefer to admit air during the day, apply a little fire heat, and close up with a dry atmosphere at night. The plants should be placed in a favourable situation in the open air, where they would not receive too much wet; it is best to elevate the pots on boards or bricks, and fill up the interstices between and over the tops of the pots to the height of 6 in., that the roots may receive no injury from frost, and where they are to remain until wanted for forcing. The compost for striking the eyes to consist of two thirds rich gritty pasturage loam to one third well pulverised old tan. The compost for growing and fruiting the plants to consist of two thirds loam, and one third well decomposed butcher's garbage, with a small portion of old tan. The pots in which they are to produce fruit to be the twelfth or eighth size; the last shifting to be performed in September. The plants will require no shifting when placed in the house to force; if shifted when forcing is commenced, they will produce a superabundance of wood, which would be injurious to the quality of the fruit. About the end of December, or beginning of January, he prunes his vines, leaving only three or four eyes to produce fruit: a portion, or the whole of

them, where a succession is not required, may be placed in a pit on a gentle bottom heat of either leaves or tan, not exceeding 65°; the atmosphere of the pit not ranging above 60°, syringing when necessary, and watering with deer-dung manure water. When the buds begin to burst, fire heat to be applied by flues, or by what he considers preferable, hot-water pipes. The vines to be stopped one joint above the fruit, removing all laterals, and allowing three bunches to remain for each pot; the atmosphere should not be allowed to rise higher than 65°, until the grapes begin to expand their bloom, when it may be gradually raised to 70°. When the fruit is set, the berries to be thinned; when stoning, the temperature of the house to be reduced a little, as much excitement at that particular time will cause them to become stunted; water to be given sparingly at that period of their growth, but to be applied copiously when the berries begin to swell. When they begin to change colour, the temperature to be raised to 75°, as heat and light are now the principal agents by which they are brought to the greatest perfection; heat is the agent by which the aqueous matter contained in the berry is changed to the saccharine, and colour is communicated to the fruit by the influence of light. It is of the greatest importance to know the sun's declination, with the latitude in which a gardener is placed, to ascertain the proper angle, at the season the fruit is to ripen, to command the most vertical sun. The sorts recommended for forcing in pots are, Black Hamburg, White Muscadine, Black Prince, White Muscat, and Black Esperione. In conclusion, he objected to the coiling system of growing vines in pots.

Mr. Caie observed: As light is one of the chief agents of vegetable life, he agreed with Mr. Judd in the great utility of constructing the roofs of hot-houses with such an angle that the sun's rays may fall perpendicularly at the particular time the crop is expected to ripen.—Mr. Keane remarked that vines raised from eyes produced the best plants; layers, when cut from the parent plant, are deprived of a great portion of sap, the vessels contract, and, consequently, the growth of the plant is much retarded; cuttings are objectionable for nearly similar reasons. He objected to butcher's garbage, as vines would grow too luxuriant to fruit the first season; would also, in pruning them, cut down to two buds, and take particular care to force them gently that the buds may break regularly. He observed, when vines were planted outside, and heat applied to the house, they were excited to put forth shoots; the sap was elaborated by the leaves, and when it descended to the roots it was chilled by the cold; the circulation was retarded until the roots were excited by the influence of the sun, when the sap was propelled through the branches to cause a second growth, which, for want of regularity of temperature, must be injurious to the future crop. He objected to the system adopted by many gardeners of cutting away so much wood at their winter prunings, as he preferred to regulate the tree by nipping off all superabundant wood in the summer.—Mr. Caie also objected to the system of cutting out much wood. In pruning all trees and plants, their habits should be properly understood; a proper equilibrium should be kept up between the roots and the branches. He always saw the best crops of grapes grown upon small short-jointed and well-ripened wood. That the cause of vines pushing out strong, rampant, and unproductive shoots, was to be attributed to improper pruning, through an ignorance of the principle of what the tree is able to bear.—Mr. Judd remarked, in objection to Mr. Keane's observations, that he preferred to cut back and allow four eyes to remain; as there would be a better chance, if it so happened that one or two of them failed to swell. In forcing vineries, he always covered the borders to excite the roots, as the success of the crop most essentially depended upon the proper temperature of the roots. From the regularity of temperature, he never saw a shanked bunch of grapes in the pot culture of the vine.—Mr. Caie agreed with Mr. Judd, that the shanking and shriveling of grapes were principally caused by an unequal temperature, as in late vineries he scarcely ever saw a shanked bunch of grapes.—Mr. Keane was decidedly opposed to the coiling system of growing vines in

pots, a system which by unfair means was puffed into public notice. Many of the magazine-reading gentry expected their gardeners ought to grow them as well as they were reported to be grown at Welbeck; and, as they had not the opportunity of sending scores to the rot-heap, their failures were charitably attributed to their ignorance.

Nov. 25. 1839.—Mr. John Fish read his essay "*On the Utility of Draining in connexion with the Growth of Fruit Trees, and Planting generally.*" He began by observing that it was not his intention to enter into a detail of the various systems of draining adopted by different gardeners, but merely to mention the plan which he always practised with success. It was, to procure earthenware tiles about 1 ft. long by 3 in. diameter, and to lay them down with a flat tile at the bottom: they are sometimes made with perforated holes to admit the water to pass off more freely; but, unless the soil is very retentive, he does not consider it necessary. The nearer these drains are placed to the surface, the better they act: they should lead into a main drain of stone or brick, with power of inspecting it at pleasure. He also saw a great deal done by brushwood-draining, which acts well for a time, but cannot say how long they will last. Draining is the first step towards the improvement of soils, and has great influence upon the purification of the atmosphere. In planting fruit trees in a retentive soil, after clearing out to a proper depth, and placing under each tree a quantity of stones, brickbats, &c., great advantage was found by having a tile-drain for each tree, leading into a main drain. This incurs a little more labour and expense, but will amply repay by having clean healthy trees with good crops of fruit. Vegetable life, he believed, is chiefly composed of carbonic acid gas, water, and oxygen. Carbon is essential to the existence of trees, and it appears probable that their vigour depends upon the quantity of carbonic acid they are enabled to absorb. Many causes are assigned for the circulation of the sap. Some have supposed the sap to rise from changes of temperature; others that the sap-vessels are furnished with valves; and a third party attributes it to the action of the leaf-buds. The last he considers the most probable: the leaves, when expanding, attract the sap nearest to them; a vacuum is created, which is constantly supplied from the fresh sap ascending from below; and this, he thinks, accounts for the motion of the sap being generally most apparent at the extremity of the branches, when they first begin to expand themselves into leaves. Sap, when first absorbed by the roots, is generally believed to be water impregnated with various substances derived from the soil or some accidental cause. These substances, some of which are useful and some injurious to vegetation, are alike absorbed by the plant, but with different results. As soon as the sap, or true blood of the tree, reaches the leaves, it is then exposed to the action of the atmospheric air, much in the same way as the blood in the lungs; with this difference, that, while animal blood principally absorbs oxygen and gives out carbonic acid gas, sap has the greatest affinity for carbonic acid, and gives out a portion of its oxygen before it is in a fit state to afford nourishment to trees or plants; and he also thinks that every part of a tree contains a fluid which is a reservoir of nourishment even in winter. Some maintain that there is first an ascending sap from the roots; and others uphold the theory that there is first a descending sap from the top, because the fluid from the top of the tree is first put in motion: but, in his humble opinion, both are very probably wrong; because, although there is an ascending sap before there is a descending sap, the motion of it does not commence at the root, but is in active movement some time in the branches before it begins to stir at the roots. As the top of a tree is more acted upon by variation of temperature than any other part, no sooner does the warmth of spring return than the uppermost buds begin to swell, and, for the purpose of developing themselves, act as so many suckers of a pump in drawing up the formerly inert but now active fluid for their support. The process goes on, commencing with the uppermost buds, the fluid in the main stem is drawn up, and that in the roots immediately follows; if there is not too much variation between the temperature of the

roots and top, which will invariably be the case in retentive soils, where draining has not been properly attended to. The sap elaborated by the first expanded leaves descends; an extension of roots takes place, as well as an extension of top; the tree is now supplied with fresh absorbing and fresh perspiring organs; a reciprocal action is carried on amongst all the parts, each acting and being acted upon by every other part. With the exception of fruits for kitchen use, he considered the size not so much the object as flavour; and every gardener is aware that a dry atmosphere, and comparative dryness in the soil are most congenial to flavour, by changing the moisture into saccharine matter. In his observations on the advantages of shallow borders, he remarked that the best-flavoured peaches he ever tasted were grown on a border not more than 18 in. deep, the subsoil of the garden being a retentive clay. The soil and clay were first cleared out to the depth of 20 in., giving it 4 or 5 inches of a slope from the wall to the walk; breadth of border 12 ft. About 3 in. of coal ashes and coarse gravel were placed in the bottom, watered and well rolled until it became like a barn floor. The soil was brought in in March; the trees were planted in April, in a bearing state, from other walls in the garden; a rubble drain was made along the length of the border and cross ones laid at about 20 ft. distance leading into it. Several loads of sandstone were placed indiscriminately in the border, during the process of bringing in the soil, for the purpose of keeping it open; which he considers a good plan. Although the wood did not grow so strong as some that were not removed, it proved better for bearing a more abundant crop, which it ripened well, while the others kept growing until Christmas or till nipped by the frost.

In France the borders for peach trees seldom exceed 1 ft. of soil, upon a dry bottom; walls seldom more than 8 or 9 feet high; and the trees renewed every seventh or eighth year, as the fruit is not considered good from trees above that age. The walls are furnished with a wooden coping about 18 in. broad, which is found a great protection from perpendicular frost; also the greater portion of the vineyards in France are on a dry calcareous soil: the best wines are made from vines growing almost entirely on rocks, as they contain a larger share of saccharine matter. We are all aware that vines will grow stronger, and produce larger fruit, in richly prepared soils; but he saw excellent crops growing entirely in gravel and lime rubbish, and ripening their fruit, which was excellent in flavour; while others which were grown in rich soil did not ripen at all, although luxuriant and fruitful. He, therefore, considers shallow borders with complete drainage as more certain to produce fruitful trees, than deep borders where the roots penetrate below the action of the atmosphere; which is always more productive of leaves and branches than of fruit. He is a strong advocate for the frequent removal of fruit trees, as it checks over-luxuriance; and a gardener of his acquaintance, celebrated for his success in growing fine fruit, removes his peach trees every year. On the advantages of cutting the roots of over-luxuriant fruit trees, he observed that Mr. Beattie of Scone cut, in July, the roots of his peach trees, within a few feet of their stems; they were thus deprived of the means of obtaining a great quantity of sap, which would be expended in the production of wood, and they became most fruitful.

Mr. Keane observed that the paper brought forward by Mr. Fish was excellent, for the great practical information detailed, for the elaborate investigation he has made, and for the lucid explanation he has given of the cause of the circulation of the sap. His observations about the formation of fruit-tree borders, in his opinion, are correct in the great advantages of having them shallow. All soils fit for trees or plants must contain one or more of the four primitive earths; the siliceous, argillaceous, calcareous, and magnesian. None of these earths, either separately or combined, will ever produce food for vegetables. Mould (the carbonaceous) is animal or vegetable decomposition: but these in a pure state do not afford nourishment for vegetable life; it is when the carbonaceous is combined with one or more of the primitive earths, and the

water that is applied, or the rain that filters through the soil is impregnated with these substances, that the food is taken up in a gaseous state by the spongelets of the tree. As the sun has great influence in producing the carbonaceous matter, and enables the plant to digest and apply this food to its various purposes, when the sun is excluded the digestion is incomplete, and, consequently, the plant becomes weak and diseased. As a proof of the great benefit of carbon, he knows that in many parts of Ireland the farmers are in the habit of paring off the surface of the waste or boggy part of their land; they then collect it into small heaps and burn it; by the process of burning it becomes carbonaceous; it is then spread on the land, and, being made soluble by rain, it becomes excellent food and produces good crops. It is a great advantage to fruit-tree borders to keep them free from weeds or crops of vegetables, as caloric (or the sun's rays) has the vivifying influence of producing the fructification of fruit trees.—Mr. Grey was sure that a little more expense in the formation of proper fruit-tree borders would be abundantly repaid by productive crops. He always observed borders highly manured with animal and vegetable matter to be the most unproductive. Trees were thus excited to produce luxuriant wood, but they rarely proved fructiferous; if the substratum is retentive, the water will stagnate and rot the roots; if it is too porous, the water will pass down quickly, by which it will carry off the carbonaceous matter, and render it unproductive.—Mr. Judd objected to Mr. Fish's system of making the bottom as hard as a barn floor, and disapproved of the practice of cutting the roots of fruit trees to make them productive, as by the proper formation of borders the roots would only receive so much nourishment as would produce small branches, which would ripen well. An equilibrium in growth should be kept between the roots and the head, without the necessity of cutting the roots to check strong-growing wood.—Mr. Grover formed the draining of his borders with brickbats and lime rubbish; the soil was made of turfy loam with a small portion of dung, the depth of the border 2 ft.; and the fruit trees always produced abundant crops.—Mr. Cooper objected to Mr. Fish's drainage of gravel and coal-ashes, as he knows coal-ashes to have a tendency to cause canker. He always formed his borders 14 ft. wide; the substratum was composed of brickbats and stones, sand, lime rubbish, and gravel as grit at the top, with a drain at the bottom 2 ft. deep, filled up with large stones, which answered well; his border from 18 in. to 2 ft., filled with maiden loam and very little dung, as he considers dung objectionable, being sure to produce rampant and luxuriant branches, which never produce fruit.—Mr. Grey saw excavations made under pear and apple trees; the roots which penetrated the subsoil were cut away with great advantage to the following crops. He saw lands which were subject to springs at certain seasons of the year very much improved by drainings, similar to those recommended by Mr. Fish.—Mr. Judd believed that roots would rarely descend by gravitation into the subsoil, if the border were sufficiently nutritious to keep them within the genial influence of the sun and air near the surface. He thinks that electricity has great influence upon the circulation of the sap; that capillary attraction is the cause of the sap expanding the top buds when it descends, as was so beautifully explained by the paper brought forward by Mr. Fish.—Mr. Keane. Plants when exposed to the rays of the sun give out oxygen, which purifies the air, and at night they vitiate it by robbing it of its oxygen. He believes that the sap descends through the bark and liber and ascends through the alburnum, and that there are lateral vessels into which the sap insinuates itself to expand the size of the tree.—Mr. Judd agreed with Mr. Cooper in his reasonable objections to dung, and considered good maiden loam, on shallow borders, best for the permanency and productiveness of fruit trees. He prefers planting fruit trees in August or September to any other time, as the leaves would elaborate the sap, which would descend and cause the root to be established before the winter commenced.—Mr. Wragg detailed the system of making fruit-tree borders in his last place, where a rise of water from springs very frequently took place, and it was there necessary to make

the borders on the top of the ground. A substratum of broken stones and gravel was laid on; the border, which was entirely maiden loam, was made 3 ft. deep at the wall, and sloped down to the edge of the old border; it was well mulched, to prevent any great drought on the surface; and the plan was found to be the best by which fruit trees could be grown in such situations.—Mr. Keane did not agree with the system Mr. Fish saw of planting fruit trees in April; he thinks, and he is glad to see that it is now almost generally practised, that fruit and other trees should be planted in the autumn, for the following reasons: the heat communicated to the earth during the summer is partly retained during the autumn; when the trees are planted at that time, the genial warmth of the soil will excite them to push fresh spongelets, and imbibe nourishment, by which they will be the better enabled to withstand the severity of the winter, and will be ready to grow with the first warmth of spring. Trees planted in April will receive such a check by removal and the soil being naturally cold, that they will not be able to form feeders in time to keep pace with trees planted in autumn.—Mr. Fish briefly replied. The removal of fruit trees, as detailed in his paper, he found to answer completely as a check to over-luxuriance, and as an excellent system for the successful cultivation of fruit trees; and also the system of cutting the roots, he saw highly beneficial in many instances; also the bending of branches, especially of young trees, which has a tendency of causing them to become fruitful sooner than they otherwise would do.

ART. IV. *Retrospective Criticism.*

ERRATUM.—In p. 91. Art. XI. line 6., for “When the plants are ripe,” read “When the plants are up.”

The Grand Conservatory at Chatsworth.—Mr. Forsyth’s dictum, that an acre of glass ought to cover an acre of ground, which no one of the least experience, one would think, could ever have asserted, has been refuted by a correspondent, who signs himself E. K., Streatham; but, as he has accompanied his remarks with some observations which, as coming from an anonymous writer, and with reference to one who has given his name and address, we cannot publish, if E. K. will favour us with his name, his article shall appear without delay.—*Cond.*

Bartram’s Botanic Garden.—It is never too late to make an apology where justice or propriety requires it, or to correct an error. I, therefore, must notice the misprint in my article, *Gard. Mag.*, vol. vii. p. 665., when writing about Bartram’s Garden. For *ten* miles read *three* miles, that being the distance of that first of American botanic gardens and collections of American trees. It is impossible I could have made this mistake, having often visited this venerable spot.—*J. M. Sept. 24. 1839.*

Disadvantage of a Gardener boarding with the House Servants of a Family.—I wish you, at the end of another year, when summing up the progress of gardening, would dilate on the disadvantage many gardeners are under, by being obliged to board in a gentleman’s house. They are thereby unable to give the science of gardening that study without which no one is scarce worthy of the name of gardener.—*W. B. Jan. 1840.*

Grafting the Orange on the Pomegranate.—In the Vol. XIII. for 1837, p. 476., you insert a notice from me, that the American consul at Malta would write to you on the subject of the oranges of that island deriving their red flesh from engrafting that tree on a pomegranate stock. You need not expect any communication from him, because he has explained the fact I was in search of, to my full satisfaction, in a letter dated July 12. 1838. He is enabled to do this from the information of Professor Terafa, of the University of Malta, and author of some works on botany. This gentleman, after noticing the general prevalence of the error in question, says: “Our blood or red coloured

orange is nothing more than a variety of the common orange, derived from a tree accidentally planted in earth abounding in oxide of iron, which in a part of the island is not uncommon; and the same being afterwards propagated by grafting, served to preserve the variety of the species, while it has not the power to change its nature." It would be well to publish this.

The general prevalence of the error into which I was led, may be known from a fact mentioned to me by my correspondent, the American consul, Wm. Winthrop Andrews; "that, in three publications which recently came under his observation, two in Italian and one in English, the authors have entertained the same opinion on the subject in question, the origin of which is now clearly ascertained."

Sir James E. Smith says, in a note in the *Linneæan Correspondence*, vol. ii. p. 454., that "Chionánthus virginicus is successfully grafted upon the common ash, a tree of the same natural order, but not of the same genus; and in the *Courier Agricole*, Paris, 1839, I find the following facts:—"M. Gabriel Simon, nurseryman at Metz, is said to have succeeded in grafting the chestnut on the oak. M. D'Hombre Tiermas, Member of the Academy of Gardening, publishes in the *Bulletin of the Free Society of Nimes*, that he, some years since, grafted the chestnut on the cork-oak tree; and that, more than 100 years ago, his maternal great-grandfather grafted upon a number of oaks a variety of chestnuts on his property of Lauvage. Three of these oaks still remain, which he shows to visitors; and, what is more remarkable, the grafts having been inserted high up the tree, the trunks push out branches of the oak, whilst the higher branches of the tree yield chestnuts of the kind called Pellegrines. The address of the *Courier Agricole* is, M. Cassin, Rue Tarane, No. 12. Post paid.—*J. M. Philadelphia, Aug. 19. 1839.*

Large Trees.—Two pine trees were recently cut down in the state of Maine. The *Portland Advertiser* says that one of them, at Liberty, measured 7 ft. diameter at the stump; it had three branches, and 10,610 ft. of square-edged boards were made from it. The other was cut for a canal at Norrigewock, and was 154 ft. long, and measured 4½ ft. diameter. (*Gazette of the United States of Philadelphia, Oct. 30. 1839.*)

The Calling of the Queen Bee.—I am gratified to find your correspondent, Mr. Wighton, satisfied with my explanation respecting the calling of the bee queen during the swarming season. And, as I take it for granted that he is really desirous of profiting by the experience of others, I readily offer him the benefit of mine in respect to his remaining doubts and opinions in other points of bee science; and, when I take the liberty of putting him right where my experience leads me to think him in error, I hope he will do me the justice to believe that I do so from no wish to disparage what he calls his "scanty apiarian knowledge," or make an unseemly boast of my "more learned experience;" but simply to contribute my mite in "establishing a clearer understanding of the points" under discussion.

The first sentence which I have to notice is one in which Mr. Wighton takes credit to himself for the discovery of a fact which even Huber had overlooked. "In an article," he says, "on the calling of queen bees, I stated my inability to account for their silence before the first swarm, except upon the supposition that the old queen went off with it eight or ten minutes (? days) before her successors left their cells. This having been ascertained to be the case, the silence is so easily accounted for, that it appears strange the inference should have been overlooked by the most able apiarians, especially Huber," &c. My explanation may probably satisfy him that the prince of bee-masters is chargeable with no such oversight. Huber knew too well how the fact stood, to express any surprise or doubt at the silence of the old queen. He knew that a queen mother is never prevented by the bees from destroying the virgin queens, if she is so disposed. Now, as the cause of piping, or calling, as I have already shown, is the rage of the virgin successor of the old queen on being prevented from destroying her juniors, Mr. Wighton will at once see that the silence is satisfactorily accounted for. The old queen meets with

nothing to excite her anger, therefore she does not express, by piping, what in fact she does not feel.

Again, after expressing his satisfaction at having his doubts on the subject of piping removed, Mr. Wighton continues: "Nevertheless, I must be allowed to point out some incongruities in his (Dr. D.'s) manner of stating certain points in his subject, as well as some very doubtful quotations from Huber." Passing by, for the present, the "incongruities," I would apply myself to the "very doubtful quotations from Huber," a phraseology which I do not very clearly understand. But Mr. Wighton, on looking over my former paper attentively, will observe that, strictly speaking, I have made no quotations whatever from Huber; but merely stated that, "as to the secret means nature employs to induce the old queen to leave her abode without having recourse to the same violence towards her successors as these last offer to theirs, even Huber acknowledges we must confess our ignorance." My authority for saying so will be found in his *Observations on Bees*, p. 172.; where he says: "To preserve the race, it is necessary that the old queen should conduct the first swarm. But what is the secret means employed by nature to induce her departure? I am ignorant of it." So much for "some very doubtful quotations from Huber."

Then, as to the "incongruities," the first adverted to is thus expressed: "He (Dr. D.) states that the queen, in the after-swarms, hearing her rivals in their cells, attacks them; some of the bees prevent her efforts, and she, in a rage, goes off, taking a part of the bees with her. By this, it appears that she leaves the hive before any of her rivals have come forth, *which certainly is not the case*; as there are frequently several queens in an after-swarm."

There are two errors here: 1. I do not state that "the queen, *hearing* her rivals in their cells, attacks them;" for, I knew she would attack them, whether they cried or not. But, 2., I do say that "she leaves the hive before any of her rivals come forth;" in opposition to Mr. Wighton's assertion that "this is certainly not the case, as there are frequently several queens in an after swarm." I have only to repeat the substance of what I said on this point in my former communication, that, as soon as the senior of the young queens leaves her native cell, which she does in a few days (not *minutes*) after the old queen has led forth the prime swarm, she hastens to destroy the royal brood still in their cells, but is prevented from doing so by the workers; and that, annoyed by the failure of her repeated attempts, she hurriedly traverses the hive, communicating her agitation to the bees, and goes off with a swarm. Immediately after her departure, the workers allow the next in seniority to emerge from her cell; but, at the moment of the exit of the swarm, there is, I repeat, *no queen hatched*. I am quite aware that there is sometimes more than one queen in a second swarm, though not at all so frequently as in a third or fourth. But this is not inconsistent with the above assertion; because, in fact, the supernumerary queen or queens are hatched during the outgoing of the swarm, after the leader has disappeared; that is, they take advantage of the confusion caused by the mass of bees, including their guards, following the departed queen, to escape from their cells, and mingle with the crowd rushing out. This happens only when the population, diminished by swarming, is scanty, and when the bees guarding the royal brood are reduced in numbers, and is of very frequent occurrence in third and fourth swarms.

The next "incongruity" is stated as follows: "The assertion that the old queen is not fiercely disposed towards the young ones is, in some degree, set aside by the after-statement, that, if delayed by stormy weather till they are hatched, she destroys them." The assertion is true, notwithstanding, in both cases. The old queen is not fiercely disposed towards the young ones *at the usual time of a first swarm coming off*, because these last have not yet reached the stage of *nymphs*, when they are sealed up. Why this should be, I do not pretend to give a reason; we can only say that such is the fact, and refer it to instinct. But, should the swarming be delayed on account of unpropitious

weather, the young queens pass into the nymph state, the instinctive aversion of the old queen is excited, and slaughter ensues.

"The idea," continues Mr. Wighton, "that the queen goes abroad in search of drones is hardly sufficiently established to warrant the conclusion derived from it by some, viz. that it is the immediate cause of swarming." That the young queen does go abroad in search of the males is a fact as well established as any other in the natural history of the insect; but that this should be the immediate cause of swarming is a notion I never before heard broached, and could never be entertained by any one who had pretensions to bee knowledge; in fact, it is not worthy of the words Mr. Wighton and I spend on it.

Hoping that these remarks may be satisfactory to your correspondent, I am, Sir, &c. — *W. Dunbar. Lockerby, Dec. 12. 1839.*

ART. V. *The Royal Botanic Garden at Kew.*

It has been currently reported, and we believe on good authority, that government has had an intention to disperse the collection of plants in the Royal Botanic Garden at Kew, and employ the ground for raising culinary vegetables, and the houses for forcing. The plants, we are informed, were in part offered to the Horticultural Society; and, in part, to the Royal Botanic Society of the Inner Circle, Regent's Park; and to the Society attempting to be established at Reading, on the foundation of the collection at White Knights. The conditions proposed to the Horticultural Society were, that they should open their gardens to the public twice a week; what were proposed to the other societies we have not heard.

Though the intentions of government have, we believe, been defeated for the present, chiefly through the exertions of some influential members of the Horticultural Society, and more especially its president; yet we cannot help deeply regretting that it should ever have been made. We regret it, first, because the collection is one of the most extensive and rich in fine specimens which exists in Europe, having been gradually accumulated through a long series of years, and at a very considerable expense to the country; secondly, because we consider it unjust towards the people, who contribute an annual sum for its support; or say for the support of the splendour of the crown, of which splendour the Botanic Garden at Kew is as much entitled to be considered a part, as the collections of pictures, statues, and books, in any of the palaces; thirdly, because in this country, where fashion is everything, we think it of great importance to all classes that the fashion of having fine gardens and rich collections of plants should be set by royalty, in order that it may prevail among the nobility and gentry; and, fourthly, that such an act will render us still more ridiculous than we are in the eyes of our Continental neighbours, who laugh at our wealth and ostentation in some things, and our meanness and want of taste in others. Whether the collection be distributed among the gardens mentioned, or given to any one of them, what security is there for its existence for any length of time? Even the Horticultural Society, flourishing as it is at present, might become bankrupt in a year or two; and, as to the other societies or gardens, they cannot even pretend to be established. The collection might almost as well be sold in lots, to whoever chose to become purchasers. There might be some show of excuse for dispersing these plants, if a rigid economy were shown in other state establishments; but, while we have three persons doing what might very easily be done by one, as in the Commission of Woods and Forests, and a number of ambassadors at the different petty states of Europe, the business done by whom would be equally well performed by the consuls at the same states, not to mention other similar cases, we cannot evince the slightest sympathy with the proposition to save two or three thousands a year, by doing away with one of the most interesting

and instructive state ornaments we possess, and one which is at the same time so beneficial to science. It is given as an excuse, that the present sovereign has no taste for botany or gardening; but that appears to us far from being a sufficient reason. The same sovereign may have no taste for pictures, or statues, or books. Would that be a satisfactory reason for disposing of the royal collections, or libraries? Supposing the taste of the sovereign to change, and botany and gardening to become favourite pursuits; is the sovereign in that case to be precluded from indulging in them? or is the country to be put to the expense of again assembling together such a collection as now exists at Kew? In the latter case, indeed, we doubt if it would be practicable to do so at any expense. Either the Royal Botanic Garden at Kew is an appendage to the crown, which the crown is allowed a certain sum to keep up, or it is not. If it is, then we cannot understand on what principle this appendage is proposed to be dispensed with, without an especial act of parliament. If it is not, then we say let the subject be discussed in parliament, and let it be ascertained how far it will be advisable to dispense with what has hitherto been considered a state ornament. We know of only two substantial arguments in favour of giving up the Royal Botanic Garden at Kew: and these are, the miserable style in which it has lately been kept up for want of funds; and, secondly, the exclusive system on which it has, till lately, been managed, from the superintendants acting on the now obsolete idea, that the king's garden ought, if possible, to contain plants which were not in the gardens of any of his subjects. This last feeling has, however, in a great measure been given up of late years; and, at all events, this reason and the preceding one call only for reform in the management of the garden, not its destruction.—*Cond.*

Since the above was sent to the printer, we have seen the *Literary Gazette* of February 22., in which is the following paragraph.

Anticipated Destruction of Kew Gardens. — The Earl of Surrey, lord treasurer of Her Majesty's household, has just made, on the part of the government, an offer to the council of the Horticultural Society, to sell the whole of the unrivalled collection of plants in the Botanic Garden at Kew. This far-famed garden was founded by a princess of the house of Saxe-Gotha, the illustrious predecessor of His Royal Highness Prince Albert, and wife of Frederick, Prince of Wales. It was laid out by Sir William Chambers. It contains, and has always contained, the finest collection in the world. It was a source of great interest to George the Third, and to his consort, Queen Charlotte; and, in more recent times, to George the Fourth, and William the Fourth: the last-named monarch erected the splendid new conservatory. The whole expense of the gardens, including every thing, even to money paid to the assistant gardeners, does not exceed 1000*l.* a year. [This must be a mistake; 2000*l.* is probably nearer the truth.] The council of the Horticultural Society refused to purchase, and expressed their sorrow and regret at the offer having been made, viewing it as a national misfortune. Since the rejection of this proposal, we are assured that in a few days the plants will be given to those who ask them. The palm-house, which contains some of the finest specimens in Europe, could not be replaced under any circumstances; the plants must inevitably perish, they cannot be removed and prosper, for they are planted in the soil. The collection, also, of Australian plants is unequalled, both in extent and in the size and beauty of the specimens; removal of them will also be followed by destruction. In fine, the garden contains the vegetable treasures brought home by Captains Cook, Vancouver, Tuckey, and other distinguished navigators; and the anticipated abandonment by the government is viewed by the whole of the scientific circles in the metropolis with feelings of the deepest regret. (*Lit. Gaz.*, Feb. 22. 1840.)

THE
GARDENER'S MAGAZINE,
APRIL, 1840.

ORIGINAL COMMUNICATIONS.

ART. I. *Notice of a Visit to Wentworth House.* By J. B. W.

WENTWORTH HOUSE, the magnificent seat of Earl Fitzwilliam, is about eight miles from Sheffield, and four from Rotherham. The *Sheffield Directory*, describing the house, states that it "has a front of exquisite architecture, 600 ft. in length; and the portico is peculiarly elegant. The hall is 60 ft. square and 40 ft. high, with a gallery 10 ft. running round the whole, which is supported by eighteen Ionic pillars, the intervening niches of which are ornamented with fine marble statues."

The house stands on one side of an immense park, which is beautifully diversified with hill and dale, wood and water, and ornamented besides with an elegant mausoleum, erected in memory of Charles, Marquess of Rockingham. Fine views of the park and adjacent scenery are obtained from a long and wide grass terrace in the pleasure-ground, which is raised considerably above the park, and supported by a stone wall. The termination of this terrace, at one end, is a temple, covering a statue of Hercules destroying the dragon. From this point there is an extensive prospect, in which, on the summit of a hill, a "graceful Ionic column, erected by the Marquess of Rockingham to commemorate the acquittal of Admiral Keppel," is a conspicuous object.

Connected with the pleasure-ground, but enclosed by a wall, is an aviary, where a number of rare and curious birds are kept: this piece of ground likewise contains a large green-house, built in the old style, showy in appearance, but, like all similar structures, quite unfit for the cultivation, or even the healthy preservation, of most kinds of plants.

Two head gardeners are employed at Wentworth; one of whom, Mr. Thompson, superintends the extensive forcing-houses, kitchen-garden, and pleasure-grounds; the other, Mr. Cooper, manages the botanic department. Mr. Cooper is justly celebrated for his eminently successful cultivation of *Orchidaceæ*. His plants, in November last, were in the highest state of health and vigour, unapproached by any that I have seen, except,

perhaps, those at Chatsworth, which, also, are excellently grown. At both places, most of the finest specimens were growing in large lumps of turfy peat, piled up, in a bluntly conical form, 6 in. to 1 ft. or more above the tops of the pots; the roots of the plants interlacing through the mass, and binding it firmly together.

Herefordshire, January 14. 1840.

ART. II. *On propagating, and preserving through the Winter, tender Plants adapted for being turned out into Flower-gardens during Summer.* By N. M. T.

OUR flower-gardens are now, during the summer months, in many cases, almost exclusively decorated with exotics; and too much cannot be said in favour of a practice that enables them to rival, for a time, the sun-lit scenes of happier climes, from which we have lately received many plants so perfectly suited to such a purpose, and so exquisitely lovely when displaying their beauty in masses, that without them our gardens would be a blank indeed. What, in all the range of floral beauty, unlimited as it is, could compensate us for the loss of even that single group, the matchless verbenas? The duration of plants used for this purpose, under the mode of culture this practice has introduced, is only annual; as they require to be propagated in autumn or spring, produce their blossoms during the season, and perish at its close. As they cannot be turned out with any certainty of success until the season is far advanced, the small plants require to be planted thick enough to cover the soil, and produce an immediate effect. Thus a moderate-sized garden requires several thousands of plants to furnish it annually, a prospect that would have appalled even the best gardeners of yore; but at the present day, where sufficient means are allowed, the propagation of the plants is a matter of no difficulty. In cuttings, put in during February or March, failures seldom occur: when they do, they are generally the effect of too much confinement, and not, as is often assumed, of too much water. As a proof that cuttings when allowed plenty of air can hardly be over-watered, see with what facility most sorts strike root in water only. Plants are continually dissipating the moisture they extract from the soil into the atmosphere that surrounds them: they are, therefore, in constant action while the least difference exists between the moisture of the soil and atmosphere; and it is only while thus employed that a plant can be said to be a living thing, inaction being as incompatible with anything possessing vitality in the vegetable as in the animal world. Therefore, plants shut up until soil, plant, and atmosphere are alike

impregnated with moisture, have every energy destroyed, and are often virtually dead long before appearances indicate it. This is too often effected by the universally recommended bell and hand glasses, producing a stagnation that speedily converts the very source of life into the cause of death, and renders the most extreme caution in watering necessary, the least excess fatal. But, allowing plants so treated ultimately to succeed, being placed where they can exist without an effort, it cannot be supposed that they will produce roots with the same despatch as those that are forced to maintain a continual struggle, and feel the want of them. For the sort of cuttings we are speaking of, during the early part of the season, double glass is altogether unnecessary: watering them overhead during sunshine, while air is admitted, will prove of more service than covering them with glasses or shading, a practice that ought to be avoided.

The inexperienced will find a frame with a little bottom heat, covered 4 or 5 inches deep with light soil, the cuttings planted in the soil, a most efficient apparatus; and those who possess a stove or hot-house will find that cuttings in pots, plunged in the bark-bed, and fully exposed to the light, will root without further trouble.

But, as I have already said, this is too simple an affair to be termed a difficulty; but the introduction of so many plants into the houses at a time when those wintered there are beginning to grow, and require more room, is a serious evil; to remove which as soon as possible, we are apt either to turn out the plants before the proper season, when they often suffer so much from premature exposure, that we are forced to replenish the beds, or endure their squalid appearance during half the season; or to retain the young plants, fifty or sixty together, in the cutting-pots, until they are finally turned out. This, no doubt, saves room, the labour of potting, and watering in a great measure; but it is the practice of the sluggard, and ought to be avoided with all his doings, as the plants invariably thrive better when potted singly, and allowed to establish themselves in the pots. To avoid these habits, and still retain house-room for more important purposes, select a sheltered spot, fully exposed to the sun, over which erect a temporary framework of rafters to support a roller, with canvass or matting. Cover the bottom of the space enclosed with sand. When the plants have been potted off, the pots filled with roots, and tolerably hardened, let them be taken to this shelter, carefully turned out of the pots, and each plant placed upon a small piece of turf previously placed upon the sand. As the plants are not expected to increase much in size while they remain here, they may be placed rather close together, thereby sheltering each other, and making the most of the space covered. As the plants are

placed, let the space between each be filled up with sand, when they will require little attention, save an occasional watering, until they are removed to their final destination. Under such a shelter, the hardier sorts, or such as have been propagated in autumn, may be placed as early as the 1st of March; the pots, and the room in the house that they occupied, to be employed in forwarding others to be treated in the same manner. High or cutting winds, heavy rains, and cold are to be guarded against, during which the canvass must remain down.

The mere saving of room is not the only recommendation such a practice possesses. When the plants are taken up with the small piece of turf attached, it will be found that they have formed numerous strong and fleshy spongioses, ready to seize upon the soil with the greatest avidity. They likewise suffer much when taken from under glass, and exposed to the direct influence of light: placed out so early, the cause is less powerful; the effect, consequently, less felt; and what they do suffer in appearance is entirely recovered while they remain where their appearance is not of the smallest consequence. Those who possess propagating-houses, and every convenience to supply the plants required of them, may deem it unnecessary to employ such an auxiliary; but the number of such is limited indeed, when compared with those who happily take an interest in a garden, and strive to make the most of the means placed at their disposal: to those who have only a green-house it is invaluable. Persons so situated would do well to propagate as many as possible in autumn; retain them in the cutting-pots during the winter, allowing them plenty of air, as the best safeguard against damp, the greatest enemy to plants at such a season; pot them off, and place them under the shelter already recommended in spring. When judiciously managed, it is surprising how many plants may be thus produced, even by a single frame. Annuals intended for planting out in beds, for which purpose there are many sorts well adapted, ought to be sown in autumn, and treated in every respect like cuttings, when they will produce a far finer display than those raised in spring.

Specimen green-house plants, in pots, placed singly or in groups upon the lawn, when properly introduced, produce a fine effect. To prevent plants so placed having their roots injured by the action of the sun upon the pots, they ought to be plunged, or otherwise covered, and proper drainage secured. This is generally effected by a stratum of coal-ashes; but I have often had occasion to plunge plants where the remains of the ashes, turned up in digging, appear unsightly in the extreme: in these cases I drained the pots containing the plants by placing a small empty pot beneath each, and found the result so satisfactory, that I have adopted this plan wherever plants are

plunged, it being free from every objection that applies to ashes. Pots are easier applied and removed; and more effectual, as by them worms are completely excluded. The plunging taking place when the pots required for drainage would be lying idle, they may be so applied without any sacrifice.

Folkstone, Feb. 16. 1840.

ART. III. *On moistening the Air in Hot-houses.* By T. APPLEBY, Gardener to T. Brocklehurst, Esq.

THE successful cultivation of orchidaceous plants being now almost an essential qualification for every gardener, I am induced to add my mite to the many useful directions that have appeared in your interesting miscellany. It is in consequence of having adopted something new (at least to me) in the method of moistening the air in our orchidaceous houses, that I am induced to send you the following account of our success.

We have two houses devoted to the culture of this interesting and fashionable family of plants. They are heated by hot water, one with round pipes, the other with square ones; and, although we had pools inside, and frequently wet the floors and the pipes, yet we still found the air much too dry. To overcome this many were our projects, and in the end it was resolved to put up a small steam boiler with a main pipe to convey the steam inside, and branch pipes to different parts, in order to fill the houses completely and equally at once with steam. This, after some little failures, and various trials, we have at length happily accomplished. The effect has far surpassed my most sanguine expectations. In twenty minutes after lighting the fire, the houses are so filled with steam that I cannot see the plants, when I am in the houses, at two yards' distance; whilst the plants themselves are covered with the finest dew imaginable, and though they have been immersed in this vapour twice a day, an hour each time, for now nearly two months, they are not in the least injured, but on the contrary highly benefited. Plants that had been at a stand here for eighteen months are now beginning to grow, while others that were sickly are now fast recovering. The most delicate flowers are not injured, nor their duration shortened; whilst many species, considered difficult to flower, are now showing buds. The benefit to those plants which are hung up in baskets, or fixed to blocks of wood, is very apparent.

I may also mention that we grow a few of the choicer stove plants amongst the Orchideæ, and their appearance shows that they derive benefit from the vapour with which they are surrounded. Some of these were infested with red spider, but this warm vapour bath was fatal to the insects, as indeed was naturally to be expected.

Having thus related to you our success, I shall now endeavour briefly to describe the apparatus by which it is effected.

The boiler is placed in the back shed, and is made of copper, and weighs 80 lbs. with the taps included. It is furnished with a safety valve, a tap and funnel at the top to pour in the water, a tap at the bottom to let out the water, another to show when there is water in sufficient to allow room for steam to be generated, and a tap at the top with a small pipe attached which nearly reaches down to the bottom of the boiler. This last is to show when the water is too low, which it does by permitting steam to escape, which would not be the case so long as the end of the attached small pipe was covered with water.

The pipe that conveys the steam into the houses is $1\frac{1}{2}$ in. diameter; it rises from the boiler 3 ft., and is then carried through the back wall down to the floor inside under the back stage; it then branches right and left to each end of the houses; is then led across each end, and on the front; the branches on the ends and front being reduced to 1-inch pipe. In those pipes, and also on the back, are holes drilled every 6 ft., into which holes small pipes 6 in. long are screwed. These small short pipes are in the form of the letter T, to throw the steam horizontally, so as to diffuse it through the air before it reaches the pots or plants.

We soon found the small pipes on the main back one were not necessary, as the steam spread itself from the front and ends quite sufficiently for our purpose. The cost of fuel for this apparatus is but trifling, and the steam and the pipe that contain it heat the houses so much, that a very considerable saving of coals in the hot-water boilers is the consequence. We have therefore attained two objects; the supplying of moisture to the internal atmosphere most effectually, and a saving of fuel.

The boiler and pipes and fitting up cost about 13*l.*; but, if we had had an iron boiler instead of copper, it would not have cost more than 10*l.*

The question now is, whether the above method is worthy of imitation. All I can say on the matter is, that both Mr. Brocklehurst (my spirited employer) and myself are perfectly satisfied with it, and I shall be happy to give any further information to you or any of your readers who may require it.

Fence, Macclesfield, Cheshire, Feb. 15. 1840.

ART. IV. *Description of the Hypsometer, an Instrument invented by John Sang, Esq., Land-Surveyor, for taking the Heights of Trees, Buildings, and other Objects.* Communicated by Mr. SANG, Land-Surveyor, Kirkcaldy.

I HAVE taken the first leisure hour to make you the instrument for measuring the height of trees and buildings which I men-

tioned to you when having the pleasure of visiting you at Bayswater. It is sent by post at the same time as this letter.

The instrument was tried on some houses and trees here, and it gave their height (especially the houses) with great accuracy. It is rather difficult to manage at first, but after a few trials it becomes quite easy. The method is as follows:—

By means of a small hook (if a knot of white cloth be attached to it, so much the better), fix the end of a tape line to the bole of the tree, at exactly the height of the observer's eye from the ground. Retire from the tree, letting the tape line unwind until, by using the instrument, the top of the tree and the end of the tape line are seen quite close together. Add the height of the observer's eye to the length of the tape line, and the sum is the height of the tree. Now, the difficulty is, to catch the image of the top of the tree in the instrument, and it is this which requires a few trials, although any person who has been accustomed to use a sextant will do it at the very first. Hold the instrument by one of the milled ends, taking care that the fingers do not project over any of the holes, and that the brim of the hat is out of the way. Apply the eye to the round hole marked *a* in *fig. 31.*, and look through in the direction of the small square hole *b*, the instrument being held so that the line joining *a b* is about level, while the large square hole *c* is turned toward the sky. You will then see some object directly through the small hole, and at the same time the image of some other object, the light from which enters the large aperture, and, after being reflected by the two mirrors inside, passes into the eye. Whatever two objects are thus seen in contact, subtend at the eye an angle of 45° , as in

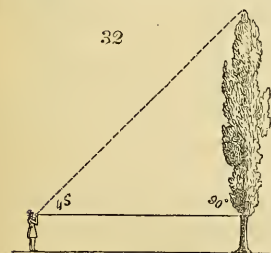
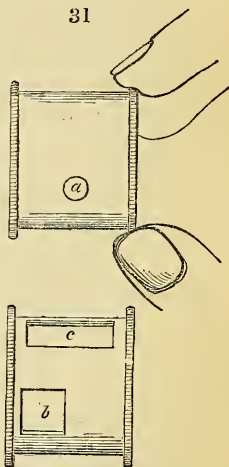

fig. 32.; so that, if one of them be the end of the tape line on a level, or nearly so, with the observer's eye, while the other is the top of a tree, supposed to be growing straight up, the distance from the eye to the bole of the tree will be exactly equal to the distance from the end of the tape line to the top of the tree.

You will thus observe that the accuracy of the measurement depends on the tree being erect from the ground. On sloping ground the measurer would require to go out from the tree in

31



such a direction that the tape line was perpendicular to the stem, but this could be judged sufficiently well by the eye to give the height, if even a very high tree, nearly correctly. The heights of those houses I tried were given within an inch, which was no doubt owing to their being perfectly upright on a level courtyard.

The principle of the instrument is quite simple, being exactly the same as that of the sextant or quadrant, only that the mirrors are fixed at a certain angle instead of being movable. Thus, in *fig. 33.*, *a* is the eye, *b* a mirror partly silvered, and *c* a larger mirror wholly silvered. A ray of light *r*, falling on the mirror *c*, is reflected from it in the direction *c b*, and again reflected from the mirror *b* in the direction *b a* to the eye; at the same time another ray of light comes from an object *o* direct to the eye at *a*, without being reflected.

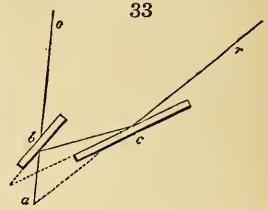

From the nature of reflected light, the angle rao is equal to twice the inclination of the mirrors, and is constant, however much the whole instrument may be moved in the plane of the objects, as you will easily perceive by catching the reflection of the candle in the instrument, and moving it in the plane of the milled ends.

I am sure this very portable instrument will be useful for measuring single trees, or buildings, which are as far asunder as they are high, but I am afraid it will not work well in a close wood, on account of the operator not having room to retire as far from the trees as their height. If this is found to be the case, the remedy is to construct another instrument in which the mirrors are placed so as to give an angle of $63^{\circ} 26' 05''$. In this case the height of the trees will be equal to twice the length of the tape, added to the height of the observer's eye. (See *fig. 34.*) Of course a small deviation from squareness in the trees and tape line will make a greater error than with the instrument sent, but still it will give a result near enough for all practical purposes.



I have only to add, that the mirrors are made of common window glass selected as the most even from among a great many pieces, but still they are not quite flat. I had some glass from London perfectly true and flat, but so dim and badly polished as to be unfit for use.

Kirkcaldy, Jan. 31. 1840.

Postscript in Answer to some Questions asked of Mr. Sang by the Conductor.

THE instrument for measuring the height of trees is not a pocket sextant, like that of Mr. Blackadder, mentioned in Vol. XIV. p. 257., although nearly allied to it. The sextant, quadrant, reflecting circle, improved Wollaston's goniometer, as well as the optical square and tree-measurer, are all varieties or improvements on Hadley's first invention. The two latter differ from the rest in the mirrors being permanently fixed at angles suitable for the purposes for which they were intended. The pocket sextant would measure the height of trees quite as well, but, being expensive, and requiring some skill to use it, it is not likely to be much employed for such purposes. There is no sort of merit in designing the instrument; and it is so exceedingly simple, that I have no doubt the idea of modifying the sextant, so as to make it readily measure the height of trees, has occurred to many a one. I, however, never heard of such an instrument, and believe that the one you have is the second of its kind in existence. The other is one which was made for yourself. My father was so much pleased with it, that he asked me to make one for him, which turned out neater than the first, and accordingly I sent it to you, as being the better of the two. As there is nothing like a Greek name for giving identity to it, you might call it a dendrometer, or, better still, a hypsometer (measure of height).

Of course any instrument-maker could supply these articles; the price, I should think, would be about 20s. each. If there were any prospect of selling a dozen or two, I could easily employ a workman here to make them, and they might be sent from the seedshop [see p. 93.] to any place by post.

Kirkcaldy, Feb. 10. 1840.

ART. V. *On Wire Field Gates.* By GEORGE BUIST.

A SINGULARLY light, strong, and unexpensive variety of field and fancy gates has of late been introduced into some of the midland counties of Scotland. They are the contrivance of Mr. George Buist, late of Fifeshire, now of Bombay. They are made wholly of iron, the frame being of light bars, the filling up of wire or small rods. The principle on which they are constructed is, that all the portions requisite for filling up the gate, and which generally only add to its weight and cumbrousness, shall be made to act as stays or strengtheners to brace up the frame; and that these, being all exposed to a longitudinal strain alone, shall be made of very small iron rods, or strong wires, which, when exposed to nearly the direction of their

greatest strength, will sustain without injury four or five times the pull to which, in gates, they have ever any chance of being exposed. Of the simplest and cheapest of these, which is merely the skeleton of the more expensive and complex one, the adjoining is a representation.

Fig. 35. represents a gate 9 ft. long, and 13 ft. in height. The framing ($a b c d$) is of light bar iron, put together in the ordinary way; $e f$, $g h$, $k l$ are straps of light iron fastened at the extremi-

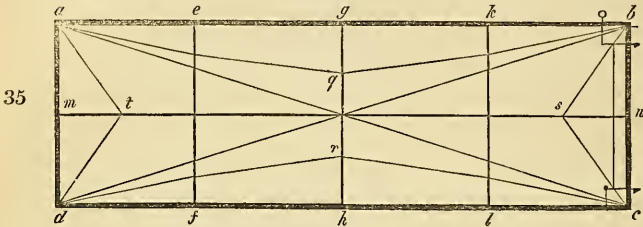

ties by rivets to the upper and lower rails, which they, amongst other things, serve to tie together. The whole of the other fillings up consist of wire or rod iron, about the thickness of a goose quill. $a c$, $d b$ are diagonals for the purpose of maintaining the gate in a rectangular form. $a q b$ is a back stay or brace for $a b$, to prevent it from bending downwards by pressure. It passes through punched holes in the straps $e f$, $g h$, and $k l$, so that $a b$ is stiffened by it at the three points e , g , and k . In like manner, $d r c$ is a back stay similarly arranged in reference to $d c$, to prevent it from yielding upwards. The three straps, $e f$, $g h$, and $k l$, connect the two rods together, and give each of them the supporting power of both back stays either way: that is, $a b$, as already shown, is prevented yielding downwards by its own proper back stay $a q b$, and it is prevented yielding upwards by the back stay of $d c$, that is, $d r c$; and so with $d c$, whose depression is prevented by the stay $a q b$, to which it is tied by the straps. So, in like manner, with reference to the ends of the gate, the stays $a t d$ and $b s c$ come into operation. Now these, when combined as in *fig. 35.*, give a system of universal bracing, such as that the framing, strengthened by them, can be disshaped by no force short of one of sufficient power to lengthen out the wires longitudinally. They form a gate, not adequate, certainly, for the retention of lambs or pigs without some additional wires, but which will keep in cattle of every sort, its largest apertures being only a triangle 15 in. by 9 in. Any sort of lock or hanging may be used which seems expedient. When a gate is suddenly shut, it will be observed to tremble and vibrate violently for some seconds, at the fore part or lower part farthest from the crook end. This, like every other kind of concussion, is of course injurious to the structure of the gate.

To remedy this, and also overcome the chance of the gate catching, two latches are here employed, one at the top and one at the bottom of the gate. This fastens the gate at once at both extremities. They are coupled together by a wire, so as to lift simultaneously on pressure at the handle above. This gate weighs about 80lb., and can be made and put up for about 1*l.* 8*s.*, a price considerably under that which is ordinarily charged for common wooden gates.

Fig. 36. is a fan wire gate. Its skeleton is exactly the same in every way with that of *fig. 35.*, only that the horizontal rail *m n*

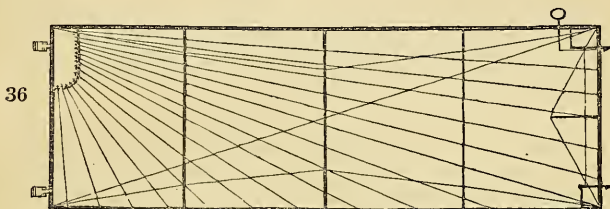

is omitted as superfluous. The wires which constitute the fan are fastened at their outer extremities by being driven up like nail heads: at the point of their convergence they are screwed tight up by a nut. They at once improve the appearance of the gate, and make it so close as to be nearly game proof, while every single ray acts as a sustainer to some part of the bar. The curved segment into which they terminate, is a strong bar similar to that out of which the upper and lower rails are fashioned. A gate of this form was made to swing for some time to and fro, with a weight of 860 lb. at its extremity, and not the slightest alteration in its shape could be perceived: its weight is from 85 to 95 lb., and it costs from 1*l.* 15*s.* to 2*l.* The only person, the excellence of whose workmanship the inventor undertakes to warrant in following out the principles on which the wire gate is constructed, is Mr. John Douglas, blacksmith, Cupar, Fifeshire; although there is nothing in their form or structure which may not be executed by any ordinary blacksmith, so soon as he comes fully to appreciate the principle. Mr. Douglas is named as having been trained by the inventor. The same principle is equally applicable to toll bars as to park gates; and, indeed, is the more important in its uses the more extended is the span of the gate. *Fig. 37.* is a park gate with wickets on this plan. The span of the gate is 12 ft.; the wickets are 2½ ft. wide, and 6 ft. high. The supporters may be made of open iron castings. The wickets could be made for about 18*s.* apiece, the gate itself for 4*l.* or 5*l.* 10*s.* in all. A very small fraction indeed of the price commonly paid for park gates of similar appearance and show. It is not yet ten months since the first of these gates was put up;

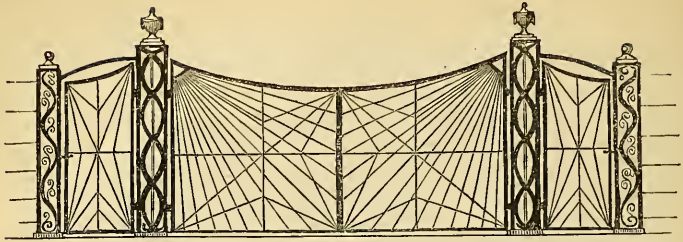

and so much have they been in demand ever since, that Mr. Douglas had orders for betwixt thirty and forty of them, of which one was for Earl Gray, Howick Hall.

London, Dec. 1839.

[THE principles of construction exhibited in these gates may afford suggestions for combinations of iron wires and rods, to serve as skeleton roofing, upper flooring of cottages, and more especially for fire-proof flooring and roofing.— *Cond.*]

ART. VI. *On the Management of Conical Boilers, with some Observations on the comparative Strength and Economy of different Kinds of Fuel.* By JOHN ROGERS, Jun., F.R.S. F.H.S.

IN drawing up the description of the conical boilers, which appeared in the *Gardener's Magazine* for the last month, I purposely abstained from any minute details respecting fuel and management. Some experiments in which I was then engaged, on the comparative efficiency, as well as the relative economy, of various kinds of fuel being now complete, I proceed to lay the results of them before the public, premising my account with a few words on the general management of the boilers, in which, as the points touched upon are of material importance, I must run the risk of a little repetition.

In the first place, I wish it to be clearly understood, that no caking or bituminous coal, or indeed any coal which produces smoke, should ever be employed, except so far as a small quantity of coal will always be found mixed with good cinders. Partial inefficiency, or total failure, and an extreme waste, will assuredly follow every attempt to use improper fuel; and cinders, coke, or Welsh coal alone are suitable.

In the next place, the chimney should not, except under peculiar circumstances, exceed 5 ft. in height, nor should the aperture of it exceed that of the top of the boiler: generally speaking, a chimney of about 3 ft. in height will be found most convenient.

Lastly, it must be borne in mind that the furnace is to be filled full of fuel; and that the fuller it is kept, the more steadily and efficiently will it work. If allowed to get low, it burns too fiercely, and heat escapes up the chimney. On the other hand, the throat of the furnace must not be choked up, or the draught may be completely checked; a few days' experience is the best guide on this point.

One word of caution may be also necessary on the subject of clinkering and stoking. I am afraid some gardeners will be quite dismayed when they are informed that the last operation is altogether inadmissible. The fuel being thrown in at the top, falls by its own weight, and must never be either poked or stirred. When the bars are clogged, they are to be cleared from below with a hook, similar to those employed in Dr. Arnott's stoves, which is furnished with the boilers. If clinkers have formed, which will be easily detected, the aperture above the bars may be opened, and the clinkers dragged out, with as little general disturbance of the fuel as possible. Where Welsh coal is employed, no clinkers are produced, which is a great recommendation of this fuel. But, under all circumstances, the aperture above the bars should be closed, as directed in my former paper, and opened only to remove clinkers. I am particular in repeating this direction, because I know that many persons will disregard it, and will use this opening to stoke the fire; the consequence of which will be, that their fires will burn rapidly to waste, and the apparatus be rendered less efficient: nothing but absolute necessity has induced me to give them the opportunity of so doing, by adopting this opening in front.

The following experiments were made with a 10-inch cast-iron boiler, of the form described in my former paper. It is set precisely in the manner there directed, with this exception, that instead of a chimney partly brick and partly iron, with a feeding-door in front, as there figured, my chimney is a mere cone of sheet iron, with a T-piece at the top, as shown in the annexed sketch. (*fig. 38.*) It is 2 ft. 9 in. high to the top of the T-piece, 8 in. diameter at the base, and $3\frac{1}{4}$ in. at the top. It is lifted on and off by hand; and, as it is never too hot to touch, if the fire be properly managed, it affords both a criterion of the management of the fire, and a proof that little heat is wasted by the chimney. It is light and easily moved, and its conical form prevents it from being easily blown off, of which there might otherwise be some danger. This boiler is attached to 44 square feet of radiating surface, in a small hot-house, 14 ft. by 12 ft. The heating pipes consist of 22 ft. of 4-inch, and 39 ft. of 2-inch, with a few feet of leaden connecting pipes, and a copper reservoir containing



45 gallons. The whole contents of the apparatus are 65 gallons, and the work performed by the boiler is about the amount which, on an average, I allot to that size.

It is unnecessary to detail, in a practical publication like the present, the exact mode of conducting the experiments. It is sufficient to say, that every precaution was taken to secure accuracy. The whole of the fuel being weighed and noted when put on, the temperature was ascertained by two self-registering thermometers, one in the stove, and one in the open air. The observations were made at 8 P.M. and 8 A.M., or nearly so; and the mean temperatures given are the mean of these temperatures thus noted, and of the minimum which occurred by night in the interval. The mean temperatures by night thus obtained, during the continuance of the experiments, are as follow:—

Outer air	-	mean	33·85°	-	minimum	21·5°.
Stove	-	ditto	65·62°	-	ditto	61°.

The mean temperature artificially maintained was therefore 31·77°.

The fuel employed in the first experiment was oven-burnt coke of the best quality, and cinders. The cinders were the ordinary refuse of the house, freed from dust and ashes by being sifted through a cross-wired iron sieve, having 16 apertures to the square inch, being one of the finest generally employed in gardens: every thing, therefore, larger than a pea, was retained as fuel; and such cinders are best adapted to these boilers.

The fire was lighted on February 10th, and continued burning for the fourteen days during which the experiment was continued. The attention it received and the ordinary management were as follows:—Between 6 and 7 A.M. the fire was cleared, and clinkered if necessary, the fire-brick plug being taken out for this purpose; 4½ lb. or one gallon of coke was then thrown in, and about an hour afterwards 9½ lb. or one peck of cinders. This fuel lasted till 5 P.M., when the fire was again cleared and made up for the night, by the addition of 9½ lb. or a peck of cinders. Slight variations took place in the management, as occasion dictated. The first peck of cinders was sometimes put on at twice, when the fire happened not to be sufficiently burnt down to receive them at once: on some days rather more was burnt, as will be seen by the average. The excess of coke, however, there indicated, arose principally from a large quantity having been employed at first, till experience showed that it not only burnt to waste itself, but uselessly destroyed the other fuel. In a short time, the quantity above stated was found to be uniformly sufficient; and I have since

found that the coke is altogether unnecessary, and my boiler is worked with cinders only.

The average daily consumption of fuel per 24 hours on the whole experiment, was as follows: coke $6\frac{1}{4}$ lb., cinders $21\frac{1}{2}$ lb.; making a total of $27\frac{3}{4}$ lb. per day, say 28 lb., something under two thirds of a bushel.*

Having obtained a satisfactory average with coke and cinders, I next tried Welsh coal: the experiment in this case was continued for seven days. 6 lb. of coke were employed on the first day in lighting it; and it took, in addition, 38 lb. of Welsh coal to fill the furnace, and get up the heat, as the water was nearly cold. After this, 19 lb. per twenty-four hours was the regular consumption; of which $8\frac{1}{2}$ lb. were put on about 7 A. M., and $8\frac{1}{2}$ lb. about 5 h. 30 m. P. M. The fire, of course, never went out during this period; indeed, not one third of the contents of the furnace was consumed in the morning.

Nothing can surpass the efficacy of this fuel: it burns entirely away without any waste; it produces neither clinkers nor smoke; and, upon an accurate calculation, the total waste by the chimney does not exceed $2\frac{1}{2}$ per cent of the heat produced; and it is more durable than any other fuel. The only precaution necessary is to break it to pieces about the size of eggs, or rather larger, using it dust and all together. As it produces no clinkers, there is no occasion to take out the fire-brick plug; and the only attention requisite is to clear the bars two or three times a day; but even this is scarcely necessary if the apertures of the bars be sufficiently large, as the coal burns entirely to dust. I find, however, that it requires rather a stronger draught than other kinds of fuel; so that, where it is to be permanently employed, the chimney should be half as high again as I have recommended above; say 4 ft. 6 in. instead of 3 ft.

It will be gathered from the foregoing details that coke, by itself, is not a suitable fuel for these boilers; unless, at any time, it be necessary to produce heat very rapidly. That which I employed is of the best and strongest quality; but, nevertheless, all coke being coarse and very porous, allows an excessive draught, and burns away rapidly, wasting much heat by the chimney; and, even if this evil could be obviated, the fuel itself being so very light, the furnace will scarcely contain enough to last twelve hours. Its specific gravity is about half that of Welsh coal; my peck of coke weighed $8\frac{1}{2}$ lb., of Welsh coal 19 lb.

Where fuel is to be bought, unless good cinders can be

* My bushel of coke weighed 34 lb., of cinders 38 lb.; but, as the quantities were taken with a gallon measure, the bushel was, I believe, a very short one. I understand 40 lb. is the average weight of oven-burnt coke. I presume, therefore, my cinders weighed about 45 lb. to the bushel; but I have given my quantities by weight, instead of measure, to preclude mistake.

obtained cheap, I consider Welsh coal decidedly superior to any other; the next best being coke breeze freed from dust by a sieve of the quality mentioned above. It is, perhaps, hardly necessary to observe, that the consumption stated above is that of a 10-inch boiler. As the boilers are proportioned to their work, a 13-inch will require nearly double; a 15-inch about three times the above given quantities of fuel.

The foregoing details supply every information which can be desired by those who employ this boiler; they show what may be expected of it, and how its utmost efficiency may be attained. I have been particular in detailing them, because they are simple and easily followed, and will, I know, insure success.

In conclusion, I would observe that a strict adherence to the instructions contained in my former paper, as to fixing, &c., is essential to the efficiency of this apparatus. If those instructions are observed, its efficacy is certain; but, in proportion as they are neglected, it will partially or entirely fail. I must at the same time remark that there is no complexity or difficulty about its operation: if it be once properly put up, its management is exceedingly easy and simple.

With respect to the boilers themselves, I recommend every one who wishes to employ them to apply to Mr. Shewen; because I know that those manufactured by him are precisely in accordance with my instructions, and a very slight deviation from their form may materially impair their efficiency. I have no pecuniary interest in the invention, nor was it ever my intention to appropriate it with that view. But, if I could have foreseen, when I first published in 1837, the experience of Dr. Arnott's stove, I should probably have taken out a patent to prevent imperfect imitations; as it is, I can only hope to attain that end by recommending a person who works under my eye, and adheres to my instructions; and I believe Mr. Shewen will be found able and willing to furnish the article upon the most reasonable terms on which it can be effectually manufactured. He will also undertake to fix the apparatus where it is desired; but, by a close adherence to my instructions, any intelligent gardener may direct the fixing of it himself. With respect to other persons who may think it worth while to manufacture these boilers, they will do well to adhere as closely as possible to my instructions.

The conical boiler, in its present form, is the result of considerable study, of some experience, and of deliberate design; and I am doubtful whether it can be materially improved. I shall, nevertheless, be most happy to receive any suggestions on the subject; but I must request that those who make them will first take the trouble to understand what they write about; and, with this view, I recommend to their attentive perusal Mr. Charles

Hood's *Treatise on Hot-water Apparatus*, where the subject is thoroughly investigated in all its bearings. In perfecting the apparatus, I have done my best; and any one who employs it, by following my instructions, may obtain my results, which, I think, ought to satisfy him.

Its adoption in various places is, perhaps, the best evidence of its efficiency. Messrs. Loddiges at Hackney, Messrs. Chandler at Vauxhall, Mr. Wilmot at Isleworth, can, I believe, give satisfactory testimony respecting it, besides many private gardeners, among whom I may mention Mr. Johnson at Strathfieldsaye. On the whole, I consider that at Messrs. Chandler's at Vauxhall the most favourable specimen of the apparatus, though there are in that one or two defects, which may be easily remedied, and which would not occur now after the more complete experience attained in that and other extensive apparatus.

Sevenoaks, March 10. 1840.

ART. VII. *Botanical, Floricultural, and Arboricultural Notices of the Kinds of Plants newly introduced into British Gardens and Plantations, or which have been originated in them; together with additional Information respecting Plants (whether old or new) already in Cultivation: the whole intended to serve as a perpetual Supplement to the "Encyclopædia of Plants," the "Hortus Britannicus," the "Hortus Lignosus," and the "Arboretum et Fruticetum Britannicum."*

Curtis's Botanical Magazine; in monthly numbers, each containing seven plates; 3s. 6d. coloured, 3s. plain. Edited by Sir William Jackson Hooker, LL.D., &c.

Edwards's Botanical Register; in monthly numbers, new series, each containing six plates; 3s. 6d. coloured, 3s. plain. Edited by Dr. Lindley, Professor of Botany in the London University.

Paxton's Magazine of Botany, and Register of Flowering Plants; in monthly numbers; large 8vo; 2s. 6d. each.

MALVACEÆ.

2005. NUTTALLIA
malvaeflora *Paxt.* Mallow-flowered $\text{♀} \Delta$ pr 1½ au P Texas 1838. D s.p [bot. vii. p. 31.
Paxt. mag. of

Very unlike the species of *Nuttallia* generally grown. It is a slender evergreen species, with flowers very like those of *Málva moschàta*. It has, as yet, only been grown in pots; but will probably prove hardy. It is propagated by division of the roots, as it is difficult to strike by cuttings; and seeds have been only very sparingly produced. (*Mag. of Bot.*, March.)

Leguminosæ.

1257. DILLWYNIA
speciosa *Paxt.* showy $\text{♀} \square$ or 2 my.jn O.c ? N.S. Wales 1838. C s.l.p [bot. vii. p. 27.
Paxt. mag. of

A robust, bushy, evergreen species of *Dillwynia*, with very showy flowers, raised by Messrs. Rollison of Tooting, from seeds received from Baron Hügel of Vienna, without their native country being mentioned. It should be managed like heaths, with the exception of adding a little loam to the heath mould in which it is grown. It is propagated by cuttings, which strike without

1840. APRIL.

difficulty; though they may be hastened by the application of "a trifling bottom heat, produced by partially decayed bark." (*Part. Mag. of Bot.*, March.)

Rosàcææ.

1515. SPIRÆA 28324 *vacciniiflora*.

† This species is figured in the *Botanic Register* for 1840, t. 17.; and Dr. Lindley observes that the species figured under this name in Loddiges's *Botanical Cabinet*, t. 1403., appears to him to be *S. laxiflora*. (*Bot. Reg.*, March.)
Gesneriæcææ.

1698. GESNERIA
cochlearis Hook. spoon-leaved ✱ ☒ or 1 jn S Organ Mounts. 1837. R s.l Bot. mag. 3787.

A handsome species, with very large, thick, concave leaves, and rather small flowers, which have a nearly equal spreading limb. Found on the Organ Mountains by Mr. Gardner. (*Bot. Mag.*, March.)

Epacrîdææ.

Lissânthe verticillata Lindl. — A plant of this rare species has flowered at the Horticultural Society's Garden; but the flowers are "very small, and of a dull purple." (*B. M. R.*, No. 26., March.)

Cactæcææ.

1472. CEREUS
leucanthus Pfeiff. white-flowered ✱ ☐ or $\frac{3}{4}$ au W Chile 1830. O s.p Bot. reg. 1840, t. 13.
Synonyme: *Echinocactus leucanthus* Gillies.

This species strongly resembles an *Echinocactus*, and the flowers, which are white, and 6 in. long, are spreading, and very handsome. "The spines are brownish when young, and spring from the midst of a quantity of brown wool, which becomes grey with age, and finally disappears." (*Bot. Reg.*, March.)

Asclepiadææ.

773. GONOLOBUS
hispidus Hook. & Arn. hispid ✱ ▲△ or 4 jl Br Brazil 1837. C c Bot. mag. 3786.

This species differs from the other species of the genus in being sub-erect and herbaceous. It also appears half-hardy, and will stand the winter in the open air, "if placed at the bottom of a sheltered wall." The flowers are "of a peculiarly thick and coriaceous texture," and of a dark purplish brown. They are large, and, being produced in clusters, are ornamental, notwithstanding their livid colour. The species is a native of South Brazil, and was sent home by Mr. Tweedie.

Solanæcææ.

591. SOLANUM
uncinellum Lindl. hook-petaled ? ○ ✱ pr jl Pk ... 1836. S c Bot. reg. 1840, 15.

A pretty little decumbent plant, with pinkish flowers, which flowered in the Horticultural Society's Garden in July, 1837, and then appears to have perished. Dr. Lindley observes that, "if the genus *Nycterium* is to be preserved," this "plant will belong to it." (*Bot. Reg.*, March.)

Acanthæcææ.

+ PHLOGACANTHUS Nees. (From *phlogos*, a flame, and *Acánthus*, the type of this family; on account of its long spike of yellow or flame-coloured flowers.)
curviflorus Nees. curved-flowered ☐ or 6 n Y.R Sylhet 1839. C co Bot. mag. 3783.
Synonyme: *Justicia curviflora* Wall.

A handsome stove shrub, with leaves about 1 ft. long; with a large thyrus-like raceme of flowers, 6 or 8 inches long. It was found on the mountains near Sylhet, and flowered at Woburn in November, 1839. (*Bot. Mag.*, March.)

Proteæcææ.

Manglèsia glabrata Lindl. — The plant is nearly allied to *Grevillea*; and the flowers, which are white, are very small. (*B. M. R.*, No. 27., March.)

Orchiæcææ.

2510. ONCIDIUM 30372 *stramineum* Bot. Reg. 1840, 14.

+ *O. Insteayi* Barker. — This species resembles *O. papilio*, except in having a stiff erect stem; and it has been named by Mr. Barker in honour of his gardener. (*B. M. R.*, No. 21., March.)

Epidendrum falcatum Lindl., syn. *E. Parkinsonianum* Hook. Bot. Mag. t. 3778. (*B. M. R.*, No. 20., March.)

+ *Broughtonia aurea* Lindl.—A native of Mexico, with bright red flowers, devoid of fragrance. (*B. M. R.*, No. 22., March.)

+ *Oberonia cylindrica* Lindl.—Flowers small, green, and arranged in a cylindrical spike. (*B. M. R.*, No. 23., March.)

+ *Brasavola venosa* Lindl.—“Resembling *B. nodosa* in habit, but with much larger flowers. The lip is white, and the other parts greenish.” (*B. M. R.*, No. 24., March.)

+ *Laelia rubescens* Lindl.—Flowers white, tinged with pink, and produced in a loose raceme. (*B. M. R.*, No. 25., March.)

2477. SATYRIUM

pustulatum Lindl. pustular ✱ Δ or 1 ... jn Pk C. G. Hope 1800. R s.p Bot. reg. 1840, 18.

This species, which was grown at Kew in 1800, and has been long lost, appears to have been lately reintroduced. Dr. Lindley, noticing the difficulty of growing Cape Orchideæ, recommends giving them a complete season of rest, by withholding water when they are not in a growing state, and also when they are in flower, at which season they should have abundance of light and heat. (*Bot. Reg.*, March.)

+ CAMAROTIS Lindl. (*Kamara*, a chamber, *ous*, an ear; in allusion to the form of the labellum.)

purpurea Lindl.; purple-flowered £ □ pr ½ my Pk East Indies 1837. D p.r.w Paxt. (mag. of bot. vii. p. 25)

A pretty epiphyte, a native of the East Indies, which formed part of the collection brought by Mr. Gibson to Chatsworth in 1837. It belongs to the section *Vandææ*, and requires a warm moist atmosphere, in which it is grown on a rough block of wood, with the bases of its roots protected with moss. (*Paxt. Mag. of Bot.*, March.)

Iridiææ.

+ RIGIDE'LLA Lindl. (*Rigidus*, rigid; rigidity of the flower stalk, when supporting the seed-vessel.)

flammea Lindl. flame-coloured □ ✱ or 5 my S Mexico 1839. S co Bot. reg. 1840, 14.

This very beautiful plant was found by M. Hartweg in Mexico, and sent by him to the Horticultural Society, where it is found to require exactly the same treatment as a *Tigridia*. (*Bot. Reg.*, March.)

Liliææ.

1016. LYLIIUM 30172 specidsum var. albifidrum Bot. Mag. 3785.

This variety Sir W. J. Hooker considers to be the *Tametoma* of the Japanese. (*Bot. Mag.*, March.)

ART. VIII. *Remarks on flowering the Renanthera coccinea.*

By J. WEBSTER.

THE treatment held forth by different authors, and the system generally adopted, to throw this beautiful orchidaceous plant into flower, is to place the plant near the glass, and withhold watering it until its stem becomes shriveled, and the whole plant assumes a withered unhealthy appearance, and then to resort to its former mode of cultivation; when the vital parts again become excited, the sap flows to the extremity of its stems, the foliage again puts forth, but, in many instances, neither a flower stem or a lateral shoot appears, to the great disappointment of the cultivator.

The following is the system which I have resorted to, and from which I have obtained the successful result of throwing it into flower with the plant in a full state of luxuriance. Having it growing upon

a log of wood, and the power of removing it at pleasure, in the early part of summer I placed the top, or growing part, nearly close to the glass, and kept up at all times a liberal supply of moisture to the bottom part, in order to keep it in a constant state of excitement; so that the sun's action through the glass might cause the young wood and foliage (whence all the nourishment flows) to become yellow and ripened, thereby retarding its growth, and causing it to put forth a flower stem with the plant in full health. Before the flower-stem appeared, the shoot attempted to break in several places, as it made progress in growing; when the stem was put forth, I lowered the plant from the glass, and the foliage again resumed its healthy appearance.

Eartham, Feb. 7. 1840.

ART. IX. *On Melons.* By ALEXANDER FORSYTH.

THE sorts I should cultivate are, a few Rocks, for their look at table at extensive entertainments; Green-fleshed, as being economical and fashionable (a middle-sized fruit about 2 lb. weight being considered the best); and Persians, such as the Sweet Ispahan and Hoosainees, for their rich aqueous pulp, and as by far the most delicate and delicious of the melon tribe.

Very early melons may be grown in pots, one plant in each, to mature one fruit, in the pine-stove, or in a house or pit on purpose, where a wholesome high temperature is maintained of 75° or 80°; the fruit may be supported by being laid on a small earthenware saucer, inverted into a larger one suspended from the roof.

Melons planted out in a ridge, on a bed of tan, dung, or leaves, under glass, may be advantageously cultivated in the following manner. In any house, pit, or frame, where an atmosphere as above described is maintained, sow some seeds in thumb-pots, one seed in each pot, which must be kept near the glass after the plants are above ground, and be allowed a free circulation of air, in order to rear the plants as robust and short-stemmed as possible; but, though I detail the process of rearing seedlings, I must not be understood to mean that they are equal to those raised from cuttings, which process I shall here detail:—

In an atmosphere as above described, let the cutting-pots, prepared in the following manner, be placed half a day previous to their being used, in order that the mould may be warm, to prevent a check by cold soil to the bottom of an exotic cutting. If provided with a small crystal bell-glass, or a small hand-light closely glazed, that may be used; but if provided with neither, which is nothing uncommon, you can doubtless command as

much glass in square or fragment, as will cover the mouth of a 48-sized pot.

The cuttings should be taken from the extremities of the healthiest vines, cut close below the third joint from the tip, and inserted in thumb-pots filled with leaf soil and loam mixed, about half an inch below the surface of the soil; and these placed in the bottom of a 48-sized pot, and the cavity between the two pots stuffed with moist moss, and the glass laid over the top of the outer pot, which ought to be plunged in a hot-bed up to the brim: this is an improvement in striking cuttings which I have never made known before, nor have I ever seen it practised by any one else. It is a common way to fill a pot three fourths full of soil, and in that to insert the cuttings under a pane of glass; and I have no doubt, when those that have practised that mode come to see this simple improvement, so much more workmanlike, and applicable not only to melon cuttings, but to all sorts of cuttings, exotic, green-house, and hardy, they will feel nowise reluctant to relinquish the old way. The advantages of this mode are, when the cuttings get up to the glass, which they generally do before they have struck root, the outer pot can be changed for one a little deeper, and the moist moss serves the two-fold purpose of conducting heat and moisture; and, as the heat of the tan or dung bed will be 30° or 40° above that of the atmosphere of the house or pit (a good tan bed will range about 110° at 6 in. deep), it will be communicated through the outer pot to the atmosphere around the cuttings, thereby accelerating their striking root: this latter is an advantage possessed in common with the old system over the bell-glass propagating pot.

To some readers this may appear trifling and tedious; but others, who have to wipe out some hundreds of propagating glasses every morning, will find it a far less laborious and equally successful method, instead of wiping the glasses, simply to turn them over. Many heaths may be struck in this manner, by letting the pots stand on a shady shelf for a few weeks, and afterwards plunging them in a mild bark bed.

But to return to the melon culture. Plants being reared, either from seeds or cuttings, healthy and robust, are, let us presume, in 32-sized pots, about 9 in. high, with leaves as large as the palm of the hand. The hot-bed being made up to within 18 in. of the glass, and a ridge of loamy turf, mixed with one fourth its quantity of dung pulverised to a mould, being laid along the centre of the bed, about 12 or 14 inches deep, a day or two previous to the planting of the melons; and all fears of offensive steam from the bed or linings being guarded against; the plants may be turned out of the pots along the centre of the ridge, about 1 ft. apart for a bed 9 ft. wide, or for a 6-foot

bed about 15 in. apart, with a fine sweet moist heat, such as could be breathed comfortably, about 75° to 85°. Excess in quantity of heat is not so much to be feared as inferior quality of heat. A strong heat will rarefy the air and cause ventilation; to facilitate which, a small aperture should be left open, say $\frac{1}{4}$ of an inch, at the top of every light, and this eighteen or twenty hours out of the twenty-four. The time that I should shut up close, would be at uncovering in the morning (which should be done as soon as it is light); and after syringing or steaming them in the evening, when no more air is wanted for the day heat.

Plants raised from cuttings show fruit with less vine than those reared from seeds; and this is the best remedy, in conjunction with keeping them rather dry at the roots, for the ever-crying evil, that the "vines have run all over the bed without showing fruit." I should prefer leaving a plant reared from a cutting entire, without stopping, until it shows fruit; those raised from seed must be topped, as they generally draw up weak and long-jointed, if left entire. I should top them for the first time, as soon as they show the rough leaf, and again as they advance, say, when they have made 2 ft. of vine, in order to produce fruitful laterals. When fruit appears, they must be carefully managed to prevent sudden atmospheric changes; and, during the time that they are in flower, water over head must be dispensed with, and gentle vapour only occasionally raised, to nourish the leaves, for it would be injurious to keep the flowers too moist at this time. Every female blossom must now be carefully impregnated; and, as soon as the fruits are set and beginning to swell, plenty of moisture and a closer atmosphere will be of the greatest service till they are swelled full size, when moisture at the root, and also vapour on the leaves, must be finally dispensed with. As soon as a reasonable number of fruits are swelling favourably, say three to six on a plant, the rest, with every leaf and lateral, for which some good reason is not pledged, must unsparingly be discarded; leaving always one leaf, or perhaps two, beyond every fruit; and let every fruit be elevated on an inverted earthen saucer. To grow very early melons, dry heat is indispensable, as every leaf, in moist weather, ought to be carefully dried once every day; and, in hot weather, every leaf ought to be as carefully moistened, by means of vapour or syringing. Before the fruit appears, and also when it is ripening off, a well ventilated atmosphere is best; but, whilst the fruits are swelling, closeness and humidity will be found to answer the purpose best. An occasional dusting of powdered charcoal and lime, mixed with sulphur and Scotch snuff, will go far to prevent the ravages of insect enemies.

The bed must be soiled over to the same depth as the ridge was originally made, at different times, as the progress of the

roots shall dictate; and the roots must be supplied with soft well aerated water, as the firmness or flaccidity of the leaves must determine. As little shading as possible should be given, as the plants should be inured to the full sun as soon as possible; the minimum heat may be 70°, and the maximum 90°, though 100° would do no harm, even with the lights close, provided the laps and crannies about them were closed, or with the lights not closed, provided the transition were not rapid.

Isleworth, October 1836.

ART. X. *On the Turkey Onion.* By JAMES ALEXANDER, late Gardener at Maeslough Castle.

I HEREWITH send you a few seeds of the new Turkish onion, the first of which I received in 1834 from Mr. Wright, editor of the *Hereford Journal*. I have grown some of the Turkey onion every year since 1834. It grows considerably larger than any other sort that I have seen; I have had some of them that weighed 2½ lb. each. I exhibited at the Hereford Horticultural Society for several years three onions of this sort, which weighed about 5 lb. 10 oz. each year; an extra prize was awarded for them every year that they were exhibited. I sowed the seeds in January in a hot-bed, and plant them out, if the weather is favourable, in the beginning of April, on a south-east border, in drills 14 in. apart, and 8 in. in the row. The ground is frequently hoed about them during the summer, and occasionally watered with manured water.

Little Chelsea, Feb. 20. 1840.

ART. XI. *On sowing the Early scarlet Horn Carrot as a main Crop; and on storing it in Winter.* By JAMES SEYMOUR, Gardener at Ashridge Park.

I MAKE my first sowing from the 1st to the 10th of February; and the second in the last week of February or the first week in March. These sowings are made upon a gentle hot-bed, using a dry sandy soil. I thin when very young, and keep a very vigilant eye to slugs when the plants are coming up; I have always found watering occasionally with lime water to destroy the slugs. I likewise make a sowing upon a south border about the first week in March, to succeed those upon the hot-beds. For my main crop, I sow from the 27th of March to the 10th of April, in rows 1 ft. apart, and the alleys 2 ft. wide; always thinning the crop when very young to about 6 in. in the row, likewise taking care to do this while it rains, if possible. If the weather proves very dry, I water pretty freely.

I have grown the Orange, Surrey long, Altringham, &c. ; and have found the Early scarlet Horn the best for our family, as it is very productive and good in quality, and does not require the depth of soil, or the distance between the plants, which the larger sorts do. I have found this sort to keep quite as well as the other kinds. I likewise sow a few rows of the Altringham and the New white Altringham for a change. I find the Altringham the best of the large sorts. The Early scarlet Horn can be sown as late as June, if young carrots are in request during summer. I have found, by sowing the same piece of ground several years together with carrots, that the roots become much more free from the attacks of the wire-worm (*E'later lineatus Linn.*) and other insects. When I came here, in the autumn of 1836, I found the carrots so much eaten and cankered that there was scarcely a free bit to be got out of a root, and they were likewise very bad-tasted. When the carrots are taken up, and all the refuse cleared away, I then give the piece of ground a good sprinkling all over with quicklime, and let it remain two or three days; then I give it another sprinkling as before, and dig it in to destroy the worms, slugs, &c., which are lower down; the drier the weather is, the better for the lime taking effect. Using lime, and digging the ground over several times previously to sowing in the following spring, are attended with a very beneficial result. In 1837 I sowed the same piece of ground with carrot, and in the autumn they were much better than in 1836. In 1838 and 1839 the carrots were entirely free from speck, and likewise well-tasted.

Taking up and storing the Roots. — When I think of taking my carrots up, I choose a dry time for that purpose, and have the tops mown off to 6 in. high, the day previous to digging them, and cleared away; I then take a three-pronged fork, and commence digging. I lay the roots in a sort of line, as they are dug up, to dry. I have likewise men to follow the diggers for the purpose of cutting the tops off, which is done quite close to the root. This is very easy to accomplish with the Altringham, Orange, &c., but requires a little more care with the Early scarlet Horn, as it is hollow-crowned, and will perhaps want cutting over once or twice from the time of taking up to the June following. I always make three sortings in my carrots: the first contains all the finest, which I keep for dinner parties, and for sending to London in the spring, when the family is there; the second sorting is for the use of the parlour; and the last sorting is for general purposes. When I begin to pack them, I do not pack them close to the wall, as is generally the case, but leave a vacuity of 8 in. on the wall side, for the cold air to pass round them, which, I find, prevents the roots from growing and rotting. I store them upon the north side of a

ground-floor apple-room, and have found them to keep very well till June.

Frithsden Gardens, Ashridge, Herts, Feb. 17. 1840.

ART. XII. *Some Remarks on the Culture of the White Carrot.*
By W. MASTERS, F.H.S. &c., of the Exotic Nursery, Canterbury.

WHENEVER a new vegetable is introduced, although I would by no means put aside the varieties in common use to which it most nearly approximates, yet I would recommend that the novelty should have a fair trial against those of long known and established repute; and then, even if it is not found in itself to be superior, before it is utterly discarded, I would ascertain if it possesses properties that, either by culture or by hybridising, would increase its own merits or those of its nearest allies. By this means we may hope that one out of many novelties will prove of superior value to those already in cultivation; and that progressive improvement will be realised, either in increased production on a given space, or in better flavour, or more nutritive qualities, in the subject of our experiments.

About seven or eight years ago I received from the Horticultural Society, and also from France, a few seeds of the White Carrot, which I sowed in the nursery in company with the sorts that are usually grown, and found the new comer increase in size more rapidly than the Orange, or even the Altringham varieties. At that time, believing them adapted only for kitchen use, we repeatedly tasted them during their growth, and also when they had acquired maturity: my friends' and my own opinion coincided; we mutually pronounced them, neither in flavour nor appearance, at all equal to the common kinds.

The greater weight that the white variety acquired, under precisely similar circumstances, was an object too important to be passed over, and accordingly several of our agriculturists were induced to grow patches of the White Carrot in their fields as food for horses; and in the neighbourhood of Ashford, in this county, many acres have been grown during the past year, and, as far as weight is concerned, with entire success. The land best adapted for its culture appears to be of a sandy character, and even in some instances a considerable growth has been obtained upon almost a pure sand. This, then, constitutes its chief value; it may be profitably cultivated upon lands that are at present utterly worthless. In our county there are hundreds of acres between Deal and the Sand Hills, now waste, that might be made to produce this vegetable; and in Suffolk, near Brandon, where many acres of a similar character exist, and that hitherto have neither yielded employment to the labourer nor profit to

the landlord, its growth might be encouraged so as amply to repay the outlay. On some of the worst soils that it has been tried upon in this neighbourhood, about a ton per acre has been produced; and upon others of a sandy nature, where cultivation had been farther advanced, eighteen and even twenty tons have been obtained upon the same space.

This variety has the power of collecting nourishment where the sorts previously grown would be incapable of procuring it; or, as the growers express it, would be burnt up. We must not, with this advantage, however, overlook its defects.

It will be readily inferred, from what has preceded, that although a greater quantity of vegetable matter is produced on a given space, yet its relative quality as food is not equal to that of other kinds; its weight and bulk being made up by a larger quantity of watery particles. This circumstance accounts for the fact, that the roots, when stored up, are more liable to decay than those of the ordinary kinds.

It may be interesting to some to know the mode of culture adopted in this neighbourhood, although it differs little from that pursued in the other varieties; and, as the season is fast approaching for sowing, I am not without hopes that it may be more extensively proved than it hitherto has been. The best time for sowing appears to be the last week of April, and the two first in May; for not only is it difficult to make the seed vegetate if sown earlier, but, of those that do succeed, many of the strong plants will put up flowering stems, and thus reduce the value and weight of the crop.

I may here caution growers against saving seeds from those plants that start prematurely, for by this practice, in a few generations, the stock would return to its wild condition, an annual; and thus, by losing its increase of succulency acquired by culture, lose all its value as an article of food.

The land should be worked till it becomes very finely broken; and the drills into which the seeds are to be placed should be very shallow. The distance from row to row must be regulated by the soil and its condition; but the space of from 10 in. to 14 in. asunder, according to the circumstances named, will be found the most proper: for it will allow ample space for the plants to grow, and gives facility to hoe and thin out the superabundant ones; which latter operation should be commenced early, or the vigour of the seedling plants will be greatly diminished.

Canterbury, March, 1840.

ART. XIII. *On the Culture and Preservation of Potatoes.* By ROBERT LYMBURN, Secretary to the Kilmarnock Horticultural Society.

In the January number of the *Edinburgh Quarterly Journal of Agriculture*, there is an essay by Mr. Aitken, nurseryman, Castle Douglass, on the culture

of the potato ; and in the *Transactions of the Highland Society*, bound up in the same number, there are a paper on their preservation for domestic use, and a digest of both papers ; also in the number for this present month there is a criticism on these by Mr. Towers, author of the *Domestic Gardener's Manual* ; and, as I think a little might be added to all these, if you think the following remarks suitable for your valuable periodical, they may help to throw a little additional light on a subject which will be allowed by all to be of vast importance. Mr. Aitken in his essay attaches great importance to the raising of new varieties from seed, the want of attention to which he describes as producing a *taint* in the potato ; Mr. Towers, in his criticism on this point, seems to think there is no foundation for this opinion, and founds his refutation principally on the new theory, lately propounded by Mr. Main, that every seed contains within itself all the parts capable of being developed in the future plant ; and that all the buds and branches to be developed in the future tree will be found contained in embryo in the seed from which it sprang. But this theory itself has yet to stand the test of experience. It will not be easy to demonstrate its fallacy from microscopical observation ; but neither can we demonstrate its truth by the same means, though, as far as observation will guide us, it is rather in favour of its truth. If it is true, however, there will be a normal quantity of parts, as, for instance, of buds : and so far Mr. Anthony Tod Thomson seems to favour this theory ; for, in his *Elements of Botany*, he says that no more buds will at any time be developed on a plant, than this normal number ; that, as the tree continues to grow, every succeeding year's growth leads from a few of the terminal buds of the previous one-year's shoot, and the others become latent or concealed below the bark ; that, as the stem swells in bulk, the buds continue to follow the bark outwards by the medullary rays of the wood ; and that, if the stem is cut over, no other buds will push but these, which, if rubbed off once, will spring again and no oftener. I have, however, often observed, in trees cut over, a far greater than this normal quantity of buds to spring ; and, in particular, I recollect of having made the observation on the stump of a tree which had been cut down at Monkwood Grove : if my recollection serves me right, it was a sycamore ; and, round the whole edge of the cut, the buds were clustered in many thousands. I pointed it out to Mr. Smith at the time, and we both remarked on the necessity of practice to the correction of theory. About two years ago, also, we had one of our dahlia roots, one of the duplicates we were springing on a little hot dung, on the crown of which, contrary to the usual number of buds, the top, which was raised into a conical shape, was crowded with hundreds of buds upon buds like bees in a hive. What shall we make, also, of the clusters of young shoots found like birds' nests on the tops of birch trees, &c. ? Are these all normal ? and would they not be much better explained by the power of that vital energy so every where present and so little known, which, as in the animal economy it is found to possess the power of forming bone and muscle and all the animal tissues from the same blood, sometimes even depositing bone in the vital organ of the heart, so, in like manner, in the vegetable economy, is found, stimulated by the accumulated deposits from the leaves in a favourable autumn, converting the leaf-bud into the rudiments of flower and fruit ; and, as in the instances above quoted, forming innumerable buds, totally independent of any former normal numbers. Mr. Towers extends this theory so far, as to reckon seeds no more important a part of the series of individual species, than the tubers of the rhizomata of tuberous roots like the potato, or than the cuttings or grafts of other plants ; but we see this series broke in upon innumerable instances, by the hybrids raised between species, which would not take place were the whole series of individuals included in their first origin.

Mr. Knight, to whose authority Mr. Towers seems to pay great deference, was of a contrary opinion. It was a favourite theory of that gentleman's, that the Golden Pippin and other old sorts of apples, though continued by grafting on healthy young stocks, would lose their vigour as the original tree decayed ;

and there was a necessity of raising new sorts from seeds, to replace the old and decaying varieties. This theory has no doubt been carried too far, it has been affirmed that all the grafts would die when the original tree died; and Mr. Aitken, I think, has also attached too much importance to it in the potato; but that it is true to a certain extent, experience will warrant us in affirming. This district, and about Paisley, has long been famous for raising ranunculuses from seed; and so superior in vigour are those recently raised from seed to the older varieties, that it is customary for florists to point out the new seedlings, in the beds of flowers belonging to their neighbours, before they have come into flower, merely by the extra vigour of the plants; and so well is this known, and so much calculated on, that it is customary to hear florists talking of destroying their old varieties, and to continue to grow from seed only: the same thing has been remarked about the seedling pinks, and we never have the large sorts of Lancashire gooseberries to come up to their first-declared weights. I am, therefore, of opinion, that more attention ought to be paid to the raising of new varieties from seed, and that much of the success will depend on selecting the best varieties to breed from, and also the most vigorous individuals of that variety; much also may be done in blending prolific and farinaceous varieties, &c. Mr. Aitken, however, I think, attaches too much importance to this. Any want of vigour arising from the age of the variety must come on gradually, and cannot, as Mr. Towers remarks, come and go with wet and dry seasons: some peculiarity must be sought for in the nature of those seasons in which the failure occurred; and to the excessive and long continued drought which prevailed throughout the most of Scotland in the years alluded to, precisely at the period when the tubers should have germinated, we must certainly look for the principal cause. We have had long continued drought in other seasons: but, if sufficient moisture is found to germinate the tubers, and allow them to protrude their fibres into the ground, they may fail in vigour afterwards from a want of moisture; the plant may not grow so strong, but the fibres are strong and active in this species of plant, and it is not easily killed when once begun to grow. As a proof that drought did the most mischief, I need only remark that, in our own experience in that greatest year of failure, we had not a single failure in the nursery grounds, where the soil was well broke with the spade and the moisture and heat retained; while the same potatoes, from the same heap, and planted at the same time by the plough in Mr. Fowld's field, were a total failure, from the rough and lumpy state of the ground: many other causes no doubt assisted. Tubers for seed too long cut and exposed to the weather, as Mr. Towers remarks, will lose their vigour; they may be thrown together in heaps after cutting, or thrust into sacks, and thus heated and spoiled; they may be too ripe when lifted, or too green; the drills may be too long exposed to drought before planting; the dung may be insufficiently rotted: all of these may cause partial failures, but the excessive and widely extended failures of these seasons were more deeply seated. Mr. Aitken's directions as to having the ground well pulverised are excellent. Too much attention cannot be paid to this: it should be broken as small as possible, and done in *dry weather*; when the particles of earth are minute, and *thoroughly* dried on the surface, they keep separate unless the after rains are heavy indeed. Confined air is retained in great quantities between the particles which retain the heat; any showers and dews that fall are not so speedily evaporated; and thus heat and moisture, two of the most principal requisites in vegetation, are greatly increased.

In planting with the plough, especially if the ground is ploughed wet, it is too often planted with potatoes in a rough and lumpy condition, and the drought penetrating, and the heat escaping, the tuber is left without the necessary agents in furthering germination; and being generally planted from cuts not whole, and thus deprived of the skin which nature has provided for its preservation, it is no wonder if it become exhausted and perish. Mr. Aitken and Mr. Towers both approve of unripe tubers being planted, and the former goes into considerable detail as to the methods of procuring these;

but I would prefer the tubers grown on peat soil to unripe ones; there is a vigour in these which cannot be attained to, though they are lifted never so green in loamy soil. Mr. Aitken advises to cut over the stems, and leave the potatoes in the ground a considerable time before raising; but, if the stems are cut so low as to divest them of leaves, they will get little good in the ground; and, if left long, the buds may shoot from the tuber, and weaken them. I would rather advise to have them taken up, and spread on the ground, and turned till the skin gets green, and something approaching to the nature of bark on the stem; every one in the practice of planting potatoes, will know the superior vigour of those cuts which are taken from the potatoes growing out of the surface and become green; and we may have the whole of our seed potatoes of the same nature, for a very little trouble. I am of opinion we may err in lifting potatoes too soon, as well as too late; when the food is first deposited as the future food of the young embryo, whether in tuber or seed, it is deposited in the form of mucilage, which is the least organised state of the sap, and it is subsequently by the deposition of carbon ripened into sugar and farina or starch. Before the starch can become food for the young embryo in the spring, it must again be reduced into the state of mucilage; the first organised state of the food is, therefore, the most suitable nourishment for the young embryo, and hence the superiority of unripe seed corn and potatoes to that which is very much ripened: but the food will not preserve and keep through the winter in this state; being so low in the state of organisation, it sooner decays, and we may err in lifting too green as well as too ripe. The food in its most highly organised state of farina or starch has been, by some of our best writers on vegetable physiology, compared to particles of mucilage surrounded with a shell; and it requires a good deal of heat and moisture, with in some cases the presence of an alkali, to reduce this starch into mucilage. The earth is the great stomach or laboratory of the food of plants; and, if we are careful to give it justice by a proper degree of pulverisation, we will have less cause to complain of too ripe seed. Mr. Aitken has given very excellent directions for the preparing of the sets, in beds set apart for that purpose, before planting out; and the lime he recommends to be sprinkled in its quick or powdery state, amongst the sets when preparing, is of great use in their germination; it furnishes the alkali required, extracts carbon from the starch, gives out heat, and assists powerfully in the solution of the food, as more particularly described in an essay of mine published some years ago in your pages. (See Vol. XIV. p. 71.)

The paper in the *Quarterly Journal* has excellent instructions for the preservation of potatoes. The principal aim of the writer is to keep the tubers from germinating, by preserving in *cool, shaded, dry* situations, and by frequent turning; this decreases the heat and moisture, which are the two most essential agents in vegetation. But I am of opinion it will be possible to destroy the vitality of the embryo, without hurting the flour of the potato. Heat and moisture are both necessary to vegetation, but they must be applied at the same time; if we apply heat without moisture to a considerable degree, we destroy the vitality of the seed altogether, without injuring the farinaceous food contained in the seed or root, so far as domestic purposes are concerned, which was the thing wanted by the Highland Society. Most dealers in seeds, and most nurserymen, are familiar with the effects of kiln-drying seed. When beech mast is collected in England for sowing, it is often immersed in water for the purpose of skimming off the bad seeds and refuse, which from their lightness rise to the top; and it is then spread on the top of a malt-kiln to dry before sending off. We have had this seed frequently sown in the nursery grounds, and exposed to all the rains that fell for six months, without vegetating, and, at the end of this time, as white and full in the kernel as when sown. The seed of larch fir, being difficult to extract from the cone, is often put on the kiln head, and we have often the same complaints of it. The seed when cut is as full of flour as before, only, if magnified, it is deficient in moisture; the substance of the food has lost its waxy appearance, but is still

as good for food to animals. I would, therefore, advise spreading the potatoes required for domestic use, for some time on a heated kiln, and they will afterwards keep for any required time on a dry loft without trouble. In the digest it seems to be doubted, whether the ripe or unripe potato will be best to keep for domestic use; but undoubtedly the ripe potato, containing most flour and being least apt to decompose, as before stated, will be most fit for that purpose. Flour is more nutritive to animals than mucilage, and the floury potato will always be selected at table, in preference to the waxy.

I perceive the Highland Society has offered this year a premium for the best essay on the excrement of plants; and if you can find room for my remarks on the subject [inserted in p. 218.], it may help some who have time and apparatus to analyse the deposit. In the case of the spruce, I think it is similar to turf, and acts both by decomposition reducing it into soluble food, and by keeping the soil open for the admission of air, which may be decomposed with the manure, and yield carbon, oxygen, and hydrogen, the three bases of all vegetable productions, and also nitrogen, a stimulant.

We have grown some of our fine plants in pots, drained with bruised bones, and have found that the fibres refused to enter it; they contracted in their length, swelled out, and had not a very healthy appearance. I think, therefore, bruised bones would not be suitable for glass cases, unless ground to very small and fermented dust; well-rotted leaves would be the safest, and animalised carbon would give the most nutriment in least bulk. Carbon is what is principally wanted as food for plants, but does not enter the spongioles of the fibres freely till converted into a saponaceous matter by alkalies; and this requisite state is best found in well-decomposed manure; a mixture of horse and cow dung, rotted into the state of a black oily peat, is generally allowed the best of all.

Kilmarnock, March 14. 1840.

REVIEWS.

ART. I. *Hints for the Use of Highland Tenants and Cottagers.* By a Proprietor. 8vo, pp. 273, 6 lithographs. Inverness.

SIR F. A. MACKENZIE, an enlightened and benevolent Highland landlord, has written this work for the benefit of his cotter tenants, and published it in pages of English alternating with pages of Gaelic. The information it contains is admirably adapted for the improvement of those for whom it is intended; and as the author does not attempt too much, and proposes to introduce every innovation by degrees, there can be no doubt of his success. The hints relate not only to the building of cottages and management of cottage gardens and small farms, but to the treatment of live stock and their diseases, to domestic economy and cookery, including the making of clothes, the treatment of common diseases, &c. In short, the work includes the following heads, which we quote to show that it is a model of its kind, and worthy of being imitated by proprietors in Wales, and in many parts of England. I. Food. II. Diseases and Medicine. III. Clothing. IV. Houses, Furniture, &c. V. Boats, Fishing Implements, &c. VI. Agricultural Implements, &c.

VII. Cattle, Horses, Pigs, &c. Diseases. VIII. Gardens, Seeds, Fruits, Vegetables. IX. Education, Morals, &c.

The following quotation may be read with advantage by all of us:—

“But, although I have not commenced by the usual formalities of a preface and introduction, it may be well, before stating the different heads under which it is intended to consider the subject of this little work, to remind you that success in any thing depends upon your own exertions, and that were the most perfect rules laid down for your guidance, the benefit to be derived depends wholly upon the mode of application. No proverb is more true than that where one man thrives another will starve; but you are not to imagine that the success of the one or the misfortune of the other depends upon blind chance. Every tradesman can perform the work in which he has been instructed, but very different indeed is the quality of work performed by each, for that depends on the ingenuity of the individual. So, in the various walks of life, he will certainly succeed best, not only who is gifted naturally with the most talent, but who calls that talent into action by consideration and perseverance, who not only weighs well the subject before commencing an undertaking, but who determines to spare no pains in putting his matured ideas into practice.

“If you closely examine your thriving neighbour, you will uniformly find him not only considerate, but constantly laborious in the attainment of some useful object. Yet it is impossible to conceal the fact, that, with the majority of you, indolence and a negligent waste of time prevail to a degree unknown in those countries where greater comfort and plenty reign; for, with every allowance for the slaving toil you undergo at seed time, your care and assiduity in harvest, and the anxiety with which you prosecute the fishing when any chance of success presents itself, every unprejudiced person will allow that your destruction of precious time is such as in any other country would prove totally ruinous.

“Keeping in view, then, that idleness is the root of all evil, be assured that if you take care of the hours the years will not be neglected. Nor is it by violent exertions for a limited period, but by an easy constant occupation of your time that you can expect prosperity.

“To impress this the more forcibly, for it is a subject of the most vital importance, I may illustrate it by two examples familiar to yourselves. Do you not generally attribute your inferior crops to the want of manure, and would not a larger quantity be of essential service? You undoubtedly will answer in the affirmative, and I can then prove arithmetically that a full supply is always in your power. For, if but one basket, containing a cubic foot of seaware, be collected each tide, or six baskets each week, and added to an equal quantity of earth, gravel, or clay, according to the nature of your lands, and mixed up with the house sweepings, ashes, and house refuse, which in a well-swept house will not be less than two baskets per week, it will stand thus:—

313 cubic feet of sea ware.

313 ————— of clay, moss, gravel, or earth.

104 ————— of house sweepings and ashes.

27)730(26½ cubic yards.

Now, allowing this compost to subside one half, it will give you rather more than 13 or 14 solid yards of the best compost manure, sufficient to dung half a Scotch acre of land for potatoes, and the acquirement of which will not occupy two hours of the time now so often wasted. To collect this in a short time would be a work of great fatigue, though by degrees it may be accomplished without inconvenience; and yet, though apparently so simple an

operation, very much depends upon the manner of conducting it. In economising your time; in employing your children thus usefully; in the difference between placing your compost in an elevated situation, or where it can receive the dropping and urine from your cows, all these considerations must be turned to account.

“Again, how often do you complain that your lands are sterile, from the heaps of stones which for ages have accumulated; yet count the stones on a quarter of an acre capable of being easily carried, and it will soon be evident what might have been effected by your ancestors during the last half century had they made the most moderate but persevering exertions. Commence yourselves and you will very soon find that by removing one stone each day, or six in each week, not only will the improvement of your fields, before a year has elapsed, astonish your careless neighbours, but exceed your most sanguine expectations; and it is no exaggeration to say, that more might thus be effected in one season than had been done in the twenty preceding by those who probably wasted two or three hours of the twenty-four in abusing the unprofitableness of the lands in their occupation, whilst the idea of actively employing the proper remedy was forgotten.”

It may be gratifying to our correspondent, Mr. Pringle, to know that the instructions for cropping gardens are those given by him in the *Gard. Mag.* for 1838, and copied into our *Cottage Manual*, of which several thousands have been circulated, and also by our permission into Wilds's *Guide to Cottagers*. A Horticultural Society, or Cottage Garden Society, established in the Highlands of Scotland by a few such individuals as the author of this work, would probably do much to improve the gardens of cottagers.

ART. II. *Catalogue of Works on Gardening, Agriculture, Botany, Rural Architecture, &c., lately published, with some Account of those considered the more interesting.*

REPORT on the present State of Whitfield Farm, and the Plan proposed for improving it. To which is added a Letter to the Tenants of Philip Pusey, Esq., M.P. for Berkshire. By John Morton. Pamph. 12mo, pp. 110, with a coloured plan. London, 1840.

This little work may be considered as a supplement to Mr. Morton's *Treatise on Soils*, reviewed in our Vol. XIV. p. 151., and which has been so favourably received by the public, and highly spoken of by Dr. Buckland and other celebrated geologists. The letter to the tenants of Philip Pusey, Esq., M.P., should be read by every landlord, as well as by every tenant. We shall be glad to hear of Mr. Morton trying Hart's improved Berkshire plough, noticed in this Magazine, p. 170.; and we should also like to see revived a three-wheeled plough, invented many years ago in Scotland, which by means of two wheels in the furrow totally prevented all friction on the lower side of the sole.

On increasing the Depth of Soils. By Cuthbert William Johnson, Esq. Pamph. 8vo, pp. 74. London, 1840.

A variety of matters are here collected together which may be read with advantage by the practical farmer, and more especially by those who have not an opportunity of perusing the *Quarterly Journal of Agriculture*, or the *Journal of the English Agricultural Society*.

A Catalogue of Plants, &c., sold by Samuel Appleby, Florist, Nurseryman, Landscape and Ornamental Gardener, &c. 12mo, pp. 12. Doncaster, 1840.

A very useful little catalogue for the amateur, which may be sent anywhere, prepaid, for 1*d.*

ART. III. *Literary Notice.*

JOURNEY from Sydney to the Australian Alps, undertaken in the months of January, February, and March, 1834: being an Account of the Geographical and Natural Relations of the Country traversed, its Aborigines, &c.; together with some general Information on the State of the Colony of New South Wales. By John Lhotsky, M.D., late of the Civil Service of Van Diemen's Land, F.R. Bot. Soc. of Bavaria, &c.

This will form an 8vo volume of from 25 to 30 sheets. Of these the first 118 pages were published in Sydney, but the edition being very small, only a few copies reached Europe. The following are some of the opinions of the press upon it, as well as on the general researches of the traveller:—

“The newest and best accounts of the interior of New Holland we are indebted for to John Lhotsky, a colonist who, from January to March 1834, travelled through the Australian Alps. He wandered through the interior of the country in a botanical and geological point of view,” &c. (*Conversation Lexicon.*)

“The general course of the Murrumbidgee is towards W.S.W., so that it would go in the Gulf of St. Vincent; but Mitchell has laid down its *embouchure* a degree more east, under the 30° 5' of latitude. More accurate accounts about the course of the Murrumbidgee have been communicated subsequently by John Lhotsky. Its inundations are considerable, exceeding its ordinary bed by about 1200 feet,” &c. (*Ibid.*)

“Besides the fidelity of the doctor's tour, there is a calm unostentatious *naïveté* running through his narrative, evincing a free and independent mind: there is no conceit, nor affectation, nor weakness, but plain truth and matter-of-fact.” (*Sydney Monitor.*)

The traveller's botanical exertions have been acknowledged in the following passage:—Lhotskya [ericoides]. Dixi in honorem cl. Lhotsky, M.D., botanici in Nova Hollandia peregrinatoris.” (*Prof. Lindley's Natural System of Botany*, 2d edit.)

MISCELLANEOUS INTELLIGENCE.

ART. I. *General Notices.*

SOIL and Vegetation supplied by Nature with Sea Salt.—The question, whether salt is beneficial as a manure, is one that does not appear to have been satisfactorily settled. The following observations are not directly applicable to it, but are offered in confirmation of a fact often stated, that the counties of England exposed to south-western gales, when these gales are violent and accompanied with rain, receive a portion of salt from the sea, and are benefited or otherwise, as the case may be, by the salt deposited on the land or vegetables. Having a window with a southern aspect, sheltered by a veranda, so that the rain never falls directly upon it, during violent south-western gales with rain, the glass is covered with spray, which, on drying, leaves a film upon the glass; on applying the tongue, this is found to be distinctly salt. After the gale of the 21st of January last, being desirous of ascertaining the fact more clearly, the film was taken off with a sponge, and having washed the sponge and evaporated the water, salt remained in crystals,

together with earthy matter, evidently derived from the gravel walk under the veranda. The quantity was about $1\frac{1}{2}$ gr. to a square yard of glass, an inconsiderable quantity; but it should be remembered, that it bears a small proportion to that which the rain must have contained; the salt on the glass being only that which was left from the spray. It would be difficult to ascertain the exact quantity, every gale from the south-west not bringing salt with it; we are distant, in a direct line, about 30 miles from the New Passage, a wide part of the Bristol Channel, and probably the nearest part from which, in tempestuous weather, the salt water becomes commingled with the air. To bring salt so far inland, in any appreciable quantity, two circumstances must combine; the union of salt water and clouds at the Channel, and a gale. In the present instance the principal quantity of salt deposited was on the 21st, only a trifling quantity afterwards, although the gale continued strong for several days after. This was confirmed by the evaporation of rain water, which fell during the gale subsequent to the 21st, which left salt crystals but in very small quantity. — *Thomas C. Brown. Further Barton, near Cirencester, Jan. 25. 1810.*

Excrementitious Exudations of the Roots of Plants.—On the subject of excrements of plants, I have often wondered that the plants pointed out as illustrations were not so apt as others which have occurred to my observation. On lifting up a bed of two-years seedling Scotch fir, or two-years seedling spruce, the ground around the roots is filled with the excrement: in the Scotch fir it assumes a white colour, similar to mushroom spawn; in some places fibrous, in others in the form of a web. In the spruce fir it assumes a yellow colour, fully more fibrous than in the Scotch fir; and I have found in practice, that, in sowing seed-beds, or transplanting trees into lines, larch sown or planted after spruce have nearly doubled the size of those planted after larch at the same time, and from the same lot of seeds or seedlings. Whether this is to be attributed to the excrement acting as manure, or keeping the ground open, or perhaps to both, the effect is very decided. On trial, the same thing is observed in all changes of plants, but in none have I perceived the contrast more than in the above.

It has been held by some that the excrement acts as a poison, and by others that growing plants frequently on the same piece of ground exhausts that piece of the peculiar nourishment requisite for the individual plant; and, in corroboration of one or other, or both of these theories, I have observed that larch does not grow quite as vigorously after larch, as planted after other plants that have less excrement than the two I allude to; but the difference is incomparably more after these, especially the spruce, though the Scotch fir is decidedly next: and, seeing the effect in giving decided vigour to young larches in the nursery after Scotch fir, I have been astonished at its being said to cause disease in the larch when planted after Scotch fir in the forest. — *R. Lyburn. Kilmarnock.*

Rural Enjoyment. — *Mrs. Montague*, who used to assert that all the arts and sciences were contained in the first grain of corn, when she held a farm at Sandleford had it tilled principally by women. They weeded her corn, hoed her turnips, and planted her potatoes. *Madame Helvetius* was a woman, in some respects, not inferior to *Madame Roland*. Having been the idol of her husband, whom, in return, she loved with the warmest affection, she became, at his death, the delight of a numerous circle of friends and acquaintances. Retired at Auteuil, she indulged the native benevolence of her disposition in administering to the wants of animals, and in cultivating plants. One day, walking with *Napoleon*, then First Consul of France, she observed to him, in answer to a question he had proposed to her, “Ah, Monsieur le Grand Consul! you are little conscious how much happiness a person may enjoy upon three acres of ground!” (*Bucke's Beauties, &c., of Nature.*)

Aiding the Germination of Seeds by Quicklime. (*G. M.* 1838, p. 71.)—Some other trials, made by ourselves and other nurserymen in the neighbourhood, have shown the efficacy of the process of preparing with lime, as compared

with the same seed not so treated ; but we have had no seed so old to operate upon since that trial. — *R. Lyburn. Kilmarnock, Dec. 18. 1839.*

The Oak. — Twelve acorns weigh an ounce, and an oak tree of a hundred years' growth may probably weigh about fifteen tons. The first year the young oak weighs about three times as much as the acorn, or three twelfths of an ounce. The second year, the young tree weighs about three times as much as the tree of one year, and the third year three times as much as the second, and so on in geometrical progression during the chiefest time of its growth. Five bushels of acorns are considered to be the produce of a good tree one year with another. (*Bradley's Works of Nature, 1721, p. 45.*)

The Mistletoe has been treated of, with respect to its method of growth, by Dr. Douglas, in the *Transactions of the Royal Society*, who has shown that it is effectual in cases of epilepsy. (*Ibid., p. 40.*)

Quercus Cérris, in Asia Minor, is described by Mr. Fellows as having leaves 8 or 10 inches long, and cut almost into ribands like the fern ; it affords excellent timber, although not a very lofty tree. (*Journal in Asia Minor, p. 272.*)

The late Mr. Roscoe originally a Gardener. — From the life of this admirable man, recently published by his son, it appears that in the early part of his life he passed several years in assisting his father (who kept a public-house and a bowling-green in the neighbourhood of Liverpool) in growing potatoes, which they took to market in large baskets on their heads, and in the care of a garden. This information is conveyed in a passage in a sketch of Mr. Roscoe's life by himself, which forms a part of the volumes published by his son, and is as follows :—

“ Having quitted school I now began to assist my father in his agricultural concerns, particularly in his business of cultivating potatoes for sale, of which he every year grew several acres, and which he sold, when produced early in the season, at very advanced prices. His mode of cultivation was entirely by the spade ; and, when raised early, they were considered in that part of Lancashire as a favourite esculent. When they had attained their proper growth, we were accustomed to carry them to market on our heads in large baskets for sale, when I was generally intrusted with the disposal of them, and soon became a very useful assistant to my father. In this and other laborious occupations, particularly in the care of a garden, in which I took great pleasure, I passed several years of my life, devoting my hours of relaxation to reading my books. This mode of life gave health and vigour to my body, and amusement and instruction to my mind ; and to this day I well remember the delicious sleep which succeeded my labours, from which I was again called at an early hour. If I were now asked, whom I considered to be the happiest of the human race, I should answer, those who cultivate the earth by their own hands.” (*Life of William Roscoe, &c., by his son, Henry Roscoe.*)

There are two points in this quotation to which we wish to direct the attention of the young gardener. The first is the frank manner in which Mr. Roscoe speaks of his early occupations and hard work, so very different from that adopted in the biography of most men who have risen to eminence from obscurity, whether these biographies be written by themselves or their friends. This, on the part of Mr. Roscoe and his son, proceeds from that fearless love of truth which exists only in noble minds, and in such as are perfectly independent of the fashionable opinions of the times. The second point to which we wish to direct the attention of gardeners is, the opinion of Mr. Roscoe, “ that those who cultivate the earth with their own hands are the happiest of the human race.” It must be understood, however, that these cultivators should have, as Mr. Roscoe says he had at the time to which he alludes, an opportunity every day of passing some “ hours of relaxation in reading books.” Let every young gardener, therefore, devote some hours daily to reading ; and let the masters of gardeners consider that this is absolutely necessary to enable young men to excel in their profession, and reduce the hours of labour accordingly. No apprentice or journeyman gardener, in our opinion, ought to work more than seven or eight hours a day. We shall mention another

fact connected with the life of Mr. Roscoe, which every gardener who either is a father, or who contemplates being one, ought to attend to; which is, that he attributes much of his conduct and principles through life (which obtained for him the esteem of all who knew him) to the circumstance of his mother, who nursed him and watched over his early education, being a woman of "superior understanding and of kindly affections." The world, as Pestalozzi has shown, is not yet aware how much of the character of every man depends upon his mother. — *Cond.*

Seeds received from Friends, more especially of plants not very common, serve as lasting monuments of friendship. The cutting of *Clématis cirrhosa*, as soon as it is rooted, shall be planted against the front of my new cottage, and ever and anon, as I go out or come in, whether alone or in the company of a friend, I shall have a living specimen of your kind remembrance to point to. If I were able to assign separate portions to all the instruments of pleasurable emotions that I have experienced, through a pretty long life, I should point to the cultivation of plants sent me by disinterested friends, as one of the purest gratifications. — *A. G.*

Burning Gas for warming Rooms or Green-houses. — Various forms of stoves have been proposed for this purpose, on the understanding, it would appear, that by applying the flame of the gas to metallic bodies, an increased degree of heat would be communicated by them to the atmosphere around them. A little consideration will show that, however the distribution of the heat may be modified by such contrivances, there can be no increase of the heating power; and that, when a certain measure of gas is fairly burned, the heat evolved into the apartment will be the same, whether the flame be disposed as a light, or made to play against metallic plates, or other combinations of apparatus. In all cases where the products of the combustion are allowed to mix with the atmosphere of the apartment, without provision being made for carrying them off by ventilation, the effects of such processes must be more or less deleterious to health, according to the proportion these products bear to the mass of air they mix in. On the whole it may be assumed, that this mode of heating apartments is the most expensive, the least efficient, and, except that by Joyce's charcoal-stove, the most insalubrious, that can be resorted to. (Extract from a paper "On the best Manner of burning Gas for supplying Heat"; by Sir John Robison, Sec. R. S. E.: read before the Society of Arts for Scotland, March, 1839.)

Mudie's Views of the Adaptations of Nature in the Vegetable Kingdom. — I have lately perused another of Mr. Mudie's instructive volumes, namely his *Autumn*, lately published by Ward and Co., Paternoster Row. The book contains some of the most original and profound philosophical views of the beautiful adaptations exemplified in the works of nature, and particularly in the vegetable kingdom. In describing what he conceives and proves to be the uses and grand office of the fungi; those "great armies of autumn," as he calls them, which decompose and destroy those vegetable and animal remains now no longer possessed of life, nor fit for the purposes of life, till the fungi have seized and reduced them to elements fitted for the living products of the following year; our author continues: —

"This brings us to the main point which establishes the grand use of the fungi, in all cases where matter in this putrefying and poisonous state cannot be decomposed by the agency of animal destroyers, or by the mechanical and chemical operations of the elements. The putrefying substance of any one species, whether plant or animal, is a poison to that species if applied to the system; and in the case of such animals and plants as do not come within the list of the scavengers of nature, whose special office is to destroy putridity, the food, whatever it may be, is a poison if taken in the putrid state; and it is to prevent the deleterious effects of this poison that the insects and the fungi, according as the general physical circumstances are more favourable to the action of the one or the other, invariably hasten to convert this poisonous matter into a simple and wholesome pabulum.

"This not only shows us very clearly what an important office those little

animals and plants perform on the grand system of nature's working, but it explains in a satisfactory manner the ground of the mistake into which those have fallen who suppose that plants, in the course of their natural operations, give out to the soil a certain matter, which is a poison to succeeding plants of the same species. It is not any thing given out by the living and healthy which has this effect ; it is the decomposition, or rather the putrefying decay, of that which has performed its functions, and requires to be converted into elementary matter, before it is again available for the vegetation of the same species."

This being a new explanation of the reason why the same species of plants do not succeed, if repeatedly sown or planted on the same spot, is at least curious. It is very different from the hypothesis of Professor DeCandolle, and others, relative to the same circumstance. The professor thinks that the roots of plants have excretory pores or ducts, by which they can reject faecal matter from the system, and that it is this ejected matter which acts as a poison, or at least as unpalatable food, to succeeding plants of the same kind. From the experiments of M. Macaire, it appears certain that plants do discharge coloured fluids into pure water, which they had imbibed in a prepared fluid, in which they had been previously placed : thus showing that the roots can emit as well as absorb fluids ; but whether these rejections be faeces, or poisonous to other plants, is still far from certain.

Mr. Mudie, reasoning from analogy, asserts that living vegetation emits nothing deleterious ; but parts of vegetables destitute of life, and in a state of putridity, he believes to be highly offensive to living plants of the same kind, and states this to be the true reason why a change of crops is necessary.

We have no practice, either in the garden or field, which bears upon these ideas, so as to furnish direct proof of their validity, or the contrary. In the fields we cultivate green crops to be ploughed down as manure ; but this is for the service of a white crop. Brank or coleseed is sometimes ploughed into a fallow intended for wheat, and frost-bitten and rotten turnips are ploughed in as a dress for barley and clover, and these succeeding crops are benefited by having to live upon the moisture and putrid remains of the interred plants. But in these cases the living and the dead are not congenerous ; and, therefore, their union does not invalidate Mr. Mudie's opinion. In the garden we are constantly burying weeds, without observing them to grow the worse for being obliged to batten on their own ancestry ; but here, indeed, where so much art is had recourse to, the affections of useless plants pass unnoticed.

Mr. Mudie enters deeply into the organisation of every living thing, and repudiates the idea, that plants or parts of plants can acquire organisation fortuitously. On this subject he is rather severe on some of our professors of botanical and other sciences. He declares that "mechanical and chemical actions, and also the passing of the one into the other, we can understand ; and the knowledge which we obtain of them from our own experiments is exceedingly useful, as applied to explain the phenomena and the action of all those parts of nature which are not connected with life, either animal or vegetable : but, when we come to consider the relation between action in dead matter, and any of the actions of life, we find ourselves beset by difficulties which we cannot overcome ; because the transition of any portion of matter from the dead to the living, or from the living to the dead, whether the living state be that of animal or of vegetable, is a mystery beyond the limits of our ordinary philosophy. Some have, indeed, stumbled upon what they supposed to be the steps of the transition here, or at least a vague sort of approximation to them ; and we have had, and have at the present day, men seated in professional chairs, authorised and appointed for the instruction of the young and the ignorant, and guarded against public enquiry by doctorial and other dubbings, who, in violence of logic and common sense, and outraging even the shadow of philosophy, speak of "organic matter waiting to be organised," and so docile withal in its nature that it is more plastic than

Hamlet's cloud, which, in the opinion of the old courtier, was, in the consecutive moments of his speaking, "backed like an ouzel, and very like a whale;" for this plastic matter is, it seems, quite ready for sea or land, for plant or for animal, and, just as the waves set or the winds blow, it may become a sea-weed or a lichen, a lettuce or a lion. — *J. M. Chelsea, Oct. 21. 1837.*

Cheap circulating Libraries. — Some years ago, a reading institution and a cheap circulating library were established in Windsor, chiefly through the influence of Charles Knight, Esq., the founder of the *Penny Magazine*. The history of this library is exceedingly interesting, and has been given in *An Address to the Subscribers, &c.*, by Mr. Knight, London, 18mo. 1833. It was to this institution that Sir John Herschel directed the address that we have quoted from in the preceding paragraph; and if we could venture to take room, we would quote largely also from that of Mr. Knight. We confine ourselves, however, to one or two sentences. "I should like," says Mr. Knight, "to see, as a branch of your establishment, a room provided, furnished with benches and a table, supplied with light and fire in the winter, and fitted out with a very few well-selected books, into which every lad of decent conduct might find admission from 7 till 10 o'clock every work-day evening. Those who know anything of the course of a working lad's life must understand the difficulties he feels, under the greater number of circumstances, of enjoying an hour of quiet after the labour of the day. He has, probably, no paternal home, and at his humble lodging he is surrounded with every thing disagreeable. He seeks his pleasures among lads similarly situated; and their evening companionship generally terminates in the ale-house. I think you might do a great good by offering such young men a warm and silent retreat for a few hours, strictly interdicting the use of any liquor, and affording no inducement but the opportunity of reading. You might do this at the charge to each of not more than two-pence a week, perhaps less. If there be any good desires in the working youth of these towns, they would be called out by such an opportunity; and if you save only one in twenty from the temptations which so easily beset the young and inexperienced, you will have your reward."

The above idea is so excellent, and so easily susceptible of being carried into execution, that we trust it only requires to be made known to be adopted in a number of country towns and villages.

In the *Penny Magazine* for Dec. 21. 1833, a notice is given of a library established on the borders, which deserves the attention of all who take an interest in this mode of communicating instruction. A sum was raised by the tradesmen and others of the town, which, with donations of books, procured above 100 volumes. The subscription for reading was a penny a month, and the second week after this was made public, there were above 100 applicants, of whom about 30 were poor labourers, or solitary females, and a greater number were boys and girls under 14 years of age. Numbers of them had not read two hours in succession for several years before. One agricultural labourer, who had been accustomed to spend his evenings talking with others at the Cross in mild weather, in the smithy at other times, and occasionally in the public-house, as soon as he had access to this library, spent his evenings at home reading aloud to his family, and in a short time his constant presence at home effected a complete reformation in his domestic economy. This man was not given to drink, nor to idleness, nor to any vice, negative or positive, whatever; he was simply troubled with ennui, and, having neither garden nor books, was driven to seek such amusement in conversation as he could get. The same individual, when relating this, concluded with the assurance, that "he had heard from others statements similar to that which he had made for himself." (*Penny Mag.*, vol. ii. p. 495.)

We beg the particular attention of master-gardeners, farm-bailiffs, and land-stewards to the above cheap and easy mode of conferring happiness on hundreds, and producing, in consequence, more contented servants. There

is scarcely any head man on a gentleman's estate, who might not be instrumental in establishing a cheap library. The proprietor and his family, the clergyman, and the medical man, will almost always be found ready to assist; and, as to getting books, every body knows how cheap they now are every where. — *Cond.*

Taste. — I take taste (when not used for the sensation of the palate, which is its proper signification) to be a metaphor to express that judgment which each man forms to himself of those things which are not contained in any certain rules, and which admit of no demonstration. Thus circles and equilateral triangles allow of no taste, because they must be as they are; but the colours they are drawn in, or the materials they are made of, as they may be varied, do depend upon fancy or taste. (*Gent. Mag.*, vol. viii. p. 81.)

The *Hampstead public Library* was opened in March, 1833, on the following terms: — Shareholders, in whom the property is vested, are to make a single advance of 1*l.*, and pay 2*s.* 6*d.* or 1*s.* quarterly. Quarterly subscribers are to pay 2*s.* 6*d.* or 1*s.* at their option. Weekly subscribers are to pay 1*d.* Each class is allowed to take out one book at a time. A room was hired, and the collection began with 200 volumes, and 15 subscribers. In three months the subscribers amounted to 100, and the volumes to 1100. At the present time, Dec. 1833, there are 124 subscribers, and 1600 volumes of sound English literature, excluding party works in religion and politics, and including the four quarterly reviews. All these works may now be read by any inhabitant of Hampstead who can spare a penny a week. The objects of the institution have been explained in a very interesting address by the Rev. George Kenrick, from which we regret that we cannot spare room to make an extract. Those who wish to establish similar institutions will find catalogues, with the laws prefixed, at the shop of Mr. Bumpus, Blue Posts, Holborn. When a national system of education is established, we trust every school will have a circulating library, maintained jointly at the expense of the parish and of the readers. — *Cond.*

The most curious Gardens in Europe, especially in Britain, about the Year 1730. — The gardens of Versailles inimitable. Those at Kensington, regulated by Mr. Wise, afford as much variety as any in Europe, where water is wanting. At Hampton Court, famous for exotics; at Versailles, no grass-work or gravel, “nor the beautiful ornaments of variegated hollies, which are the glory of the English gardens.” Gardens of Holland, without turf, gravel, or evergreens; famous for bulbs grown in peat earth and sea sand. The gardens of Amsterdam exceed all others in variety of curious and useful plants, from every quarter of the world; next, that of Paris, under Antoine Jussieu; next, Leyden, under Boerhaave. The chief garden in England is that of Badmington, “whose rarities were collected by that incomparable lady the Duchess of Beaufort.” The gardens belonging to Samuel Reynardson, Esq., at Hillingdon, near Uxbridge; and the collection at Mitcham, raised by Mr. Dubois; and at Cheam, in Surrey, by the care and skill of that excellent florist, the Hon. Lumley Lloyd, D.D.; with which we must also mention that numerous collection made by the ingenious Mr. Thomas Fairchild, at Hoxton, from every one I have yet named both at home and abroad. (*Bradley's Works of Nature*, 1721, p. 189.)

“My curious friend, Samuel Reynardson, Esq., of Hillingdon, near Uxbridge, has raised several new kinds of peaches and grapes from seeds.” Pears, apples, &c., raised from seeds in Devonshire, Herefordshire, and other parts of England, and continually afford new varieties. The gardens of the neat houses exceed all others in Europe for variety of wholesome produce; herbs, salads, early cucumbers, cauliflowers, melons, winter asparagus, &c.: the best school for a kitchen-gardener; though Battersea affords the largest natural asparagus, and the earliest cabbages. The gardens about Hammersmith famous for strawberries, currants, gooseberries, &c. Mr. Millie, at North End, affords cherries, apricots, &c., some months before the natural season. (*Ibid.*, p. 181—191.)

The Leaves of Orange Trees, or other evergreens, will strike root and produce perfect plants, if they are well watered and kept in the shade, as myself and Mr. Thomas Fairchild of Hogsden, with some others, have experienced. (*Bradley's Works of Nature*, 1721, p. 41.)

Citrus nobilis.—The clove, or mandarin, orange I find well worth culture for its fruit for the dessert. One tree here has produced nearly three dozen fine fruit; and I have no doubt that a well-established tree would produce five or six dozen annually. To insure success, the scion should be in a torpid state; that is, the tree from which it is taken should have finished its spring growth, or not have begun it; and the stock should be in a growing state. — *W. Brown. Merevale Hall Gardens, Warwickshire, Jan. 1840.*

Preserving Dahlia Roots.—There is always a difficulty among dahlia-growers in preserving the roots through the winter; not so much on account of frost, as moisture. Mine of last autumn were carefully taken up, and, as I imagine, thoroughly dried, and laid on shelves in a room from which all cold and moisture were excluded by one of Arnott's smaller-sized stoves. They were bedded in malt cooms or chives [the withered roots and germs which drop off when turning the malt], which I was induced to make trial of in the absence of sufficiency of sawdust at the time of storing. On examining them a few days ago, the chives were found moist, mouldy, and heated, to the manifest injury, and indeed partial destruction, of the roots. Of course, they were immediately unpacked; all the malt chives removed; such roots as had been destroyed were thrown aside, and the remainder returned to the shelves on which they were before laid, but without any covering. So far as present appearances go, they are safe. I am told that the moisture would not have appeared but for the warmth of the room. Certain it is, that the fermentation arising from the malt chives, let it originate how it may, must be injurious to the vegetative powers of the plant. Whether the same thing would have happened with dry sawdust, I do not know. — *S. Taylor. Whittington, Stoke Ferry, Norfolk, Jan. 10. 1840.*

A'rabis purpurea is peculiar to the sides of Mount Olympus in Bithynia, and has never been heard of elsewhere. Mr. Fellows found it growing on rocks, with a beautiful flower, looking like a kind of dwarf stock; and, being much pleased with it, he made a drawing, on showing which at the Linnæan Society he procured its name. (*Journal in Asia Minor*, p. 119.) Such a plant as this, in a flower-garden, will be interesting to the classical reader, as raising associations of a favourite country. — *Cond.*

Salvia patens should now be taken from its winter retreat; and, if it has not been cut down before, that operation should now be performed, and the plant brought near the light, and where it may receive the advantage of 45° or 50° temperature, and plenty of air. The nature of this plant is to break from dormant buds underneath the soil, and near the collar, when the roots emerge. After it has become strong, the old soil should be displaced as much as can be effected without injury to the roots, and the plant repotted in good turfy loam and rotten dung, in the proportion of one of dung and three of loam. By doing so successively as it requires it, in the course of the summer it will become a magnificent object. A plant we had here in the preceding year was truly so, and the delight of every one who saw it; measuring 5 ft. high, and extending in the same proportion, and covered with a great profusion of its rich azure blooms. — *John Duncan. Henbury, March 11. 1840.*

ART. II. Foreign Notices.

ITALY.

Po'PULUS fastigiata at Pavia.—It was about 1833, that from pure ignorance an object of the greatest curiosity in the history of Lombardy was destroyed,

and which had stood for three centuries as a testimony of the defeat of Francis I. of France by Charles V.; and this was the *Pópulus fastigiàta*, which the said Francis, after the famous battle, half a mile from the Rocca Mirabella at Pavia, struck with his sword as an emblem of repentance for having offered battle—that sword which was soon to pass into the hands of the conqueror.

Milan.—Brera. The locale of Brera was consecrated to public instruction on the suppression of the Jesuits in 1773, and since that time has borne the name of the Palace of Science. The library contains about 200,000 volumes. The generous Empress Maria Theresa, and her son the Archduke Ferdinand, greatly enlarged it; and as many of the best works on the study of physics and natural history were wanting, the empress wished to obtain, at the expense of 2,000 louis d'ors, the valuable library of the physician and naturalist Haller, which contained 13,500 volumes, including manuscripts, amongst which there were even sixty volumes containing the dried herbarium collected by this distinguished botanist; but this herbarium was taken possession of by the French when they invaded Lombardy, and was dispersed in France. The Emperor Joseph II. also endowed it with very valuable gifts. The Botanic Garden is used for the instruction of the students who study philosophy at the two Licei of Milan. It is not rich in plants, but well arranged, and well cultivated. Amongst the plants growing in the open air, a *Stercùlia platani-fòlia* is much admired, the height of which is 56 ft., with a trunk 4 ft. 2 in. in circumference, at one foot from the ground; *Salisburya adiantifòlia* (male), 64 ft. high, circumference of the stem 4½ ft.; *Càrya olivàfòrmis*, 70 ft. high, circumference of the stem 5 ft.; *Gymnócladus canadénsis*, 64 ft. high, circumference of the stem 4 ft. 4 in.; *Fàgus sylvàtica atropurpùrea*, 50 ft. high, circumference of the stem 5 ft.; and, lastly, a *Juniperus virginiana* 60 ft. high, circumference of the stem 5 ft. Among the green-house plants worthy of notice are, a *Gardènia* and a *Thunbèrgia* about 9 ft. high, and a beautiful specimen of *Phytèuma albiflorum*. The present professor and director of the garden is the celebrated botanist Balsamo Crivalli.

The Imperial and Royal Villa. The villa is a palace of a tolerable size, where the court, when it is in Milan, spend the summer agreeably. The garden is in the English style, not large, but well laid out.

Commercial Horticulturists in Milan. Having spoken to you of all the gardens in Milan that merit attention, either as to the mode of cultivating the plants, or of those that are rare or of great age, I now proceed to tell you something of the establishments of Horticultural Botany which are in Milan, or scarcely without its walls. There are many who trade in plants, but the principal are Messrs. Burdin, C. Longoni, and Tagliabue. The establishment of Signor Burdin, besides being larger than either of the other two, covering a space of 86 Milanese perches, is also richer in plants. They published a catalogue of the plants which they possess, a copy of which I send you, and in which you will find some instructive notices about their cultivation. — *G. Manetti. Monza, April 24. 1839.*

We have to apologise to our correspondent for not inserting his letter sooner, but it was unfortunately mislaid. — *Cond.*

GREECE.

Mode of felling Trees in Greece. — “The bark (of fir trees) is cut for 2 or 3 feet, and the trunk wounded with the long knife of the people; afterwards, for a season, the turpentine bleeds from these cuttings, and they then set fire to it, thus consuming the trunk to the depth of about 1 in.; the tree is then again chipped, and the fire applied to the new discharge of inflammable sap. Some years are thus employed in felling a large tree, which at last falls, borne down by a heavy gust of wind. After the tree is cut down, the slow habits of the people are still shown in their further operations. The small branches alone are cut off for fire-wood; the trunk is then chipped or grooved on the upper side, so as to catch the rain-water, to promote the decay of the wood; and in this state the tree lies, sometimes across a path, which is turned in

consequence for several years, until, falling to pieces, the parts are carried away on the camels and asses employed in the trade of furnishing fire-wood to the villages and seaports. The timber, although extremely straight [? the silver fir], and good of the kind, is used for no other purpose than fuel, except the smaller trees, which are laid in lines around the cultivated grounds as fences; the branches soon harbouring luxuriant vegetation, and forming a thicket, through which the cattle seldom break. (*Journal in Asia Minor*, p. 258.)

The Corn-Drag of Greece is described by Mr. Fellows, in his *Journal*, p. 70. as a thick plank of timber, flat on the under side, which is stuck full of flints, or hard cutting stones; and the corn being spread out on hard rocky ground, this instrument, being drawn over it, cuts the straw as well as separates the grain. It is also described by Paul Lucas, in his *Voyage dans la Grèce*, and by Virgil in his *Georgics*, and Varro in *De Re Rustica*. The Prophet Isaiah alludes to it, when he says, "Behold I will make thee a new sharp thrashing instrument having teeth." (*Ibid.*)

A Classical Lease. — In Fellows's *Journal in Asia Minor*, p. 30., an ancient Greek inscription is copied, which appears to relate to the planting of a garden with cypresses at a certain period, and to the tenure of the garden, together with dwellings annexed to it. The translation, as given by Mr. Yates, in the Appendix to the *Journal*, p. 313., is to this effect; viz. that the ground was given to build upon, "during the existence of any tree planted in the time of Cratævus (the hedge of 170 cypresses was planted by him)." Mr. Yates remarks that an interesting fact is here proved, viz. the use of the cypress for hedges in ancient times. From the inscription it would appear, that the lease would not expire till these 170 cypresses were dead. (*Ibid.*)

NORTH AMERICA.

Great Price for a Plant of Morus multicaulis. — The annexed is the substance of a written communication from Mr. Ebenezer Warner, of Belchertown, Massachusetts, to the *Hampshire Gazette*, under date of August 24. 1839: — "Remarks having been made in the *Hampshire Gazette* about a white mulberry tree which I sold last winter for the extravagant sum, as was then thought, of 50 dollars, it may be interesting to mulberry dealers to be made acquainted with its origin, and to know what has become of it. About the year 1830, I purchased some white mulberry seed in New York, which I sowed in my garden in Belchertown. Among the seedlings were four trees of unusual thrift, and larger leaf than the others, one of which was removed from the nursery into the street in front of my house, where it now stands. It has so large a leaf as to attract the attention of travellers, especially of mulberry dealers. Last winter (1838-9), a mulberry dealer from Connecticut, who had seen the tree when clothed with foliage, asked what I would take for it. I stated 50 dollars, and he said he would take it. I afterwards understood that he sold it for about 150 dollars to another dealer, who, within the last three weeks, told me that he had sold many of the buds at one dollar each; that he attempted to start the buds in a hot-house last winter, but none vegetated; that in the spring he inserted some buds into the roots of the white mulberry stock which have grown 7 ft. this season; that the leaves are larger than any multicaulis leaf to be found in his vicinity; that about 2500 buds were taken from the tree the last winter and spring; and that there is at this time probably not less than 3500 equally fair and good buds on the tree. He also said, he had been offered for the tree and this year's product, the very handsome sum of 5000 dollars, which offer he denied."

The Mascall Plant. — This extraordinary vegetable production (a description of which has never been published) is only to be found on the Rio Grande, and its tributary streams, north west of the Mexican republic: it grows spontaneously on the most barren and sterile mountains in that country, and is as much esteemed as an article of food by the Mexican Indians as is the buffalo,

the elk, and the deer, by their more northern neighbours. The mascall grows in the shape of a cabbage head, and may be found as large in size as a half barrel; it is thickly covered with sharp prickly protuberances to the length of from 12 in. to 18 in.; the root is very small; the head has also a thick covering of leaves, much resembling in shape those of the plantain tree, which are very juicy, and, when prepared for eating in the same manner as the head, afford a sweet and nutritious beverage, answering every purpose to allay thirst.

The process used for cooking this plant is very singular, yet, if digressed from in a single instance, the mascall is spoiled and rendered unfit for use; it consists of digging a hole or pit in the ground to the depth of 4 or 5 feet, which must be covered with a layer of heated rocks, on which the mascall is to be placed with the root downward; a thick coat of leaves and bushes must be thrown over the mouth of the pit, over all of which is to be laid a thin coat of dirt, just sufficient to prevent the heat or steam from escaping. In this situation must the mascall remain (according to Indian computation) for three days and three nights, when it may be taken out, and will be found perfectly cooked, and most delicious food. In flavour it resembles a ripe mellow peach, each succeeding day adding to its good qualities; it increases in excellence by age. On this plant alone do the Indians subsist for months, being perfectly satisfied with their food, and esteeming it above all other. About half a pound of mascall is by them deemed sufficient to satisfy the cravings of hunger for a day, and is always carried with them on their hunting and other excursions. As I before observed, the leaves of this favoured plant contain a rich and delightful beverage, altogether forming a most extraordinary combination of food and drink, thus affording another illustration of the beneficence of a kind Providence, in securing even to the wild and untutored savage a luxury which their more favoured and civilised brethren might well envy.

I have seen the mascall so thick in some places as to form an almost impenetrable forest of thorns, as formidable in appearance as would be the same number of glittering spears, covering the whole expanse of country as far as the eye could see, in travelling through which the incautious or unwary will be reminded by a gentle stab, of the necessity there is to have a care.

I may also mention that many of the peasantry of the states of Lonora and Chihuahua, bordering on this country, also cultivate the mascall in their fields and gardens, and, I have been informed, distil from it liquor, which is said to be excellent, and not inferior to the best Jamaica rum. (*St. Louis (Missouri) Argus*, August, 1839, sent by J. M.)

ART. III. *Retrospective Criticism.*

MR. ROGERS'S Boiler and Mr. Beaton's Remarks.—I have perused with great pleasure the accounts of Mr. Rogers's boiler by himself, p. 132., and the remarks by Mr. Beaton, p. 129. There is little doubt that this mode of warming must finally become universal; and that, at no distant period, flues on the old system will be looked on much in the same light as the fireplaces in the baronial halls of our ancestors, in some of which we are told a jackass laden with wood was thrown, the chimney, no doubt, being wide enough to allow the said ass to escape. The principal object of the present notice being to correct a mistake Mr. Beaton has fallen into, and to suggest a mode of correcting it, I shall commence by copying that part of his article which contains it.

“The boiler is yet susceptible of improvement. In its present form it is made up of two concentric cones, joined at top and bottom by flanges sufficiently wide to leave a space of one or two inches between them for the water. The fire is applied in the inner cone. There is a defect in the outset, which is soon detected in practice. As soon as the fire begins to burn clear in the inner cone, the heat is generated faster than the small body of water can

absorb it, and steam is soon produced. There is a small pipe fixed in the top of the boiler, with a steam valve to guard against accidents. By close attention to the fuel and damper, this steam might be avoided, and only as much heat produced as could be absorbed by the water; but this requires too great a nicety for so simple an apparatus. Instead of having the inner part of the boiler a cone, let us have it more of a cylindrical form; this would reduce the size of the fire and the surface to be heated, and it would increase the space for the water in the same ratio. Probably some modification of this kind would simplify the working of the boiler, by producing no more heat than is absorbed by the water. At any rate, we must get rid of the steam, at least till the water in all the pipes is heated to 200°."

The misapprehension Mr. Beaton appears to be under with respect to the steam, is as to the cause of its generation. This does not proceed from the heat being generated too fast for its absorption by the water, but by the existence of a vacuum somewhere either in the boiler or pipes, most probably in the latter, and the communication between the hottest and coolest parts of the water intercepted. In order to correct it, he must contrive to have the whole body of piping completely filled, and the supply-tank partly full, before he lights the fire. If this be done, the effect of the application of heat is to set the water in motion where it is in contact with the fire, causing it to circulate through all its extent, until it is returned in a cooler state to the boiler to undergo successively the same operation. To effect this, attention must be paid to the air-cock, if there is one; if not, holes must be drilled in the higher parts of the pipes to allow the air to escape, and the water to show itself running out of the orifice; which holes any blacksmith can drill, and they may be closed by simple plugs. In order to have the most advantageous result, the water ought not to boil, but stop short of that degree of heat, say 200°; and to make this most excellent apparatus perfect, the manufacturer should estimate the exact quantity of pipe each size will heat to that temperature. I believe it would be better to have nothing to do with steaming the house from it, but that a simple machine should be made for the purpose, as suggested by Mr. Beaton, whose idea of steaming houses, either simply or with tobacco, I think admirable, and most easy of adoption, possibly by simpler and more economical means than even that which he recommends. If, however, it be thought advisable to use Rogers's apparatus for that purpose, care should be taken to have a complete stop-cock, so as to separate the pipes entirely from the boiler during the operation. By preventing the water in the pipes from being heated to a point short of boiling, little waste of water takes place, and the tank should be in such a situation that it may always insure a supply sufficient to keep the pipes full.

I do not see the advantage Mr. Rogers states, of having the pipes very much higher than the boiler, which may either entail a necessity of sinking the boiler deeper than is convenient, or of raising the pipes above the ground level, about which they ought to lie, and always at the outside or near the point of the greatest cooling surface. I should think one foot, his minimum, quite sufficient, and doubt there being any advantage in having them higher. It is evident there must be a maximum, and that a given quantity of fuel, however applied, can only heat a certain quantity of water; but it is a very considerable quantity, with such an apparatus as this, if confined as here stated, and no waste allowed by generation of steam. The parties alluded to by Mr. Rogers, instead of forcing fire upon the boiler, had better have increased the quantity of piping, and consequently the radiation of heat. If any part be defective, or rather if the air be confined in any part of the pipes, it will be discovered by that part remaining cool when the water short of it in the circulation is hot, and an opening should be immediately made.

Having explained the mistake on which the reasoning of Mr. Beaton appears to be founded, his recommendation of an alteration in the form of the boiler becomes unnecessary. In fact, the cylindrical form would be worse than the present, and the reverse of any advantage gained by the adoption

of it. If any form is better, it is the inverted cylinder, and its being made to resemble a limekiln in form: this may be worth the consideration of Mr. Rogers and the manufacturer; but I suggest it with diffidence, doubting whether the theoretic calculation of its advantage would be followed by a corresponding practical result. There is one point to which the attention of the manufacturer should be especially called, which is the cleansing. Mr. Rogers states that the boiler can be taken to pieces, and there is a valve in the plan for the purpose of cleaning it. Both these advantages ought to be rendered as perfect as possible in practice, and to be within the power of any country workman to manage. Were this attained, I see no plan likely to compete with that of Mr. Rogers for simplicity and facility of working, on a small or even on a rather large scale. I should like to see an account of the absolute quantity of water a 15 or 18 inch boiler would heat to 200°, which Mr. Shewen could easily give; and I agree with the proposition that the 4-inch pipe is the best as a general standard of reference and comparison.—*W. Darlington. March 10. 1840.*

Mr. Penn's Mode of Ventilating, &c.—Why did you not mention your own experiments on heating by hot air? I know the house in Dickson's nursery at Edinburgh, in which you tried these experiments [in 1804]. This house is standing there now, or rather I saw it there in 1837. Mr. Rogers's pit is a most excellent one, and is just as useful for keeping up a circulation of cool air in cold pits in damp weather, as for circulating hot air. How singular that I did not find out this system many years since, when I used to lay iron pipes through the centre of bark beds in Mr. Knight's manner, to get out heat from the centre for assisting the heating of the house, and to keep down violent bottom heat. I had one end of the pipe out through the brickwork of the tan bed at the level of the path, and the other end just above the tan at the farthest corner. I recollect the draught of air going in at the lower end would put out a candle in an instant. How stupid of me not to have found out Penn's system by this simple contrivance! I think you might notice in the *Gardener's Magazine* how easy it would be to put the air in any pine stove or frame in circulation, by passing two small tubes diagonally through the bark bed; the lower end to be level with the path at each corner of the bed in front, and the pipes to come out or rise through the back corners of the bed, and be carried up near to the glass.—*D. Beaton. Kingsbury, March, 1840.*

The Conservatory at Chatsworth. (p. 103.)—I received your note of 7th January, and in reply I will take its separate "counts," one by one. First, then, you say, "As to a rood of glass covering a rood of ground, that is impossible if any slope is allowed; and as the most general slope for a large house is, or ought to be, not very far from 45°, your calculation will be considerably far from the truth." You will see a perch of glass roofing a perch of ground; that is, a perch of glass lights, heats, &c., a corresponding perch of plant-stage, or vine-trellis, or bark bed for pines; in a range of small houses glazed in wood, near the north wall of the kitchen-garden at Syon. [A sketch of this house was sent, but we consider it unnecessary to engrave it, as the description given below answers ever purpose required for Mr. Forsyth's object.] "The general slope" (to use your own words) "ought to be not far from 45°." a fruiting pine-house, when thus constructed, and with upright front glass (as perhaps you will say it "ought to have"), will be not far from bearing the following proportions; say 12 ft. wide, 15 ft. high, with 3 ft. 6 in. of upright glass in front. The length of glazed work in the cross section of such a house will be nearly 20 ft.; and supposing the house 50 ft. long, it will contain 1000 ft., besides gable-ending; and supposing this good old-fashioned house to have 3 ft. all round, occupied as fireways and footways, including the walls of the bark bed, it will leave a clear pine bed only 6 ft. wide, which multiplied by 50, the length of the house, gives 300, which is not one third, but as 3 to 10, of what I am prepared to show can be got by the following arrangement:—

Suppose, then, a house built, the angle of the roof of which is not 45° , but from 15° to 20° , or, as gardeners generally term it, 1 ft. rise in 3 ft. flat; and having a bark bed nearly parallel with the roof, and at the distance under it of say 4 ft., and arranged so that, should light pass through the glass at right angles, it might illuminate all the bed and no more. By this you will see that I mean to have no upright glass in front, and no wall supporting the ridge of the roof. I see just as much reason for there being a wall to lean a hot-house roof against, as there would be for a wall to support the ridge of every cottage roof, instead of tying the rafters in couples, and making each support itself. The fireways and footways, not being benefited by light, should certainly be the shades in the picture, and be roofed with a stronger and less polished material, for the same reasons (for you are determined to give and get reasons for all that you advance or accept) that the selvages of fine cloth are made of a coarser wool and homelier colour than the web; and doubtless this is done for the sake of greater strength and cheapness, and to enhance the brighter qualities of the web by a powerful contrast. But to return to the pine house, and in few words to sum up all. The pine bed will thus be in extent perch for perch with the glass roof, and therefore will contain, by the former calculation, as many pine plants in a house 12 ft. wide and 30 ft. long, as the good old-fashioned house will hold in 100 ft. long, and the same 12 ft. in width; a back wall to support the ridge will be done away with, and the pine-bed, plant stage, vine or peach trellis, &c., placed parallel with the glass; all the fireways and footways will be stowed into the shaded parts, and the northern boundary, whether it form a vaulted aile or a plain opaque roof, never allowed to make a less angle with the glass roof than 90° .

I have one reason more to urge in favour of this system of hot-house building, and that is one that is seldom if ever attended to; I mean the deposition of damp or dew, and consequently the drip of water on plants and people from the inside of the glass of a hot-house in cold weather. In a frosty night you can scrape from the inside of the glass this frozen dew, which, when thawed, falls like heavy rain. I have often observed the water running down the insides of the cast-iron rafters of a cool green-house in the mornings; and comparing these with wooden rafters under similar circumstances, and although the glass in both cases were alike moist, the iron being such an excellent conductor of heat and cold, the inner surface would be found nearly as cold as the external air, and consequently dew or damp was deposited in abundance on its cold surface; whereas the wooden rafters seemed to resist heat, cold, and dew. Now, applying this to hot-house building, every change of temperature, either in the open air or in the hot-house, causes the deposition of more or less dew; but the plastered ceiling of the pathway beneath a tiled or slated roof will be much less affected by changes in the temperature than the glass roof will, and consequently will not collect a tithe of the damp to drip on people that it would. I was very much amused once, to see a venerable horticulturist with a quantity of grapes grown in a cool green-house, which, when brought into a warm vinery to be weighed, quickly changed from a jet black to a silvery grey, by the deposition of dew upon their cold surfaces, to the utter astonishment of the worthy representative of the old school, who had then completed half a century in the study and practice of gardening, and could never account for this unexpected metamorphosis. But this will be the less to be wondered at, when I tell you that an early edition of *Mawe's Gardener*, and *Don's Catalogue*, comprised his library of garden literature. *Mawe's Gardener*, if I recollect aright, was an heir-loom in the family, but *Don's Catalogue* he certainly purchased on his own account, and it was the only act whereby he was ever known to patronise the learned in a business that had brought him an independent fortune.—*Alexander Forsyth. Alton Towers, February 8. 1840.*

Sir John Robison's Plant Case. (p. 117.)—I should recommend the introduction of an alteration which I am under the necessity of making, to avoid

the injury done to the flowers by the fall into their florets of the heavy drops of warm water which fall from the surface of the flat horizontal plate when the sun is bright upon it; by giving to the roof a pitch of about 15°, the same plate which now forms the flat ceiling will, when cut lengthways into two, admit of a ridge pole or astragal of sufficient strength to carry the plates securely. I hope the little work you mentioned as being in preparation by Mr. Ward will soon appear. I find that Mr. Maconochie (son of Lord Meadowbank) has during nearly 15 years been making experiments on plants in glass cases, and has at present plant cases and their contents of nearly that standing; he is going to write a communication on the subject to be read to the Royal Society. I shall not fail to send you an abstract of it. — *John Robison. Edinburgh, March 5. 1840.*

Braithwaite's Kitchen-Range.—A friend has handed me your valuable and extensively circulated Magazine of January last, in which, at p. 40., you have unintentionally given an account of a cooking apparatus exhibited here, which is so erroneous, as to have a tendency to prejudice the public against its adoption; the account bears the address of W. Wild, Hertford, Dec. 1839. I trust you will kindly make a counter statement, particularly as regards the means of *roasting* (the extract stating "that the means are dispensed with," which I take to imply that the apparatus will only bake); the ovens are *Roasting Ovens*, upon the same principle as that described in your No. for December, 1839, p. 727., differing only in having the proceeds of combustion to descend and pass under them, before going into the chimney, instead of passing directly upwards; the same small fire working both the hot plate and boilers, as well as communicating sufficient heat to the closets below, before its exit. The chief novelty in the apparatus is, that the upper flues and sides of the ovens next the fire are coated with Stourbridge bricks, which not only modify and equalise the heat, but retain it; by which a most important saving of fuel is effected, the apparatus being capable of cooking more than double the quantity that any range of its size can do, at considerably less expense of fuel, as well as being more cleanly and more easily worked. — *G. M. Braithwaite. White Lion Court, Cornhill, Feb. 26. 1840.*

Ulmus fulva, the slippery Elm, *Arb. Brit.*, vol. iii. p. 1407.— In my opinion, the inner bark of the branches of this tree ranks as the first demulcent in the American materia medica; and, as long since as the year 1803, I proclaimed its merits, in an article added to that on the elm, in my edition of Dr. Willich's *Domestic Encyclopædia* (of which a large edition was sold), and also in the *Philadelphia Medical Museum*, vol. i., in which I noticed it among other medicinal trees and shrubs, natives of the United States. Since that, the delightful mucilage of the inner bark has been extensively used, in cases where a powerful emollient was required. Nothing can equal a poultice of the pounded bark with water, to bring a gunshot wound to a healthy suppuration. The Indians taught the frontier medical men this secret, and they informed the United States' army surgeons, from whom I acquired the knowledge of the remedy in this case. In dysentery it is eminently beneficial, and operates like a charm; and yet, with the most ample public testimony in its favour, the editor of the materia medica part of the *American Dispensatory* speaks slightly of it; a full proof that he has had no experience of its good qualities. I will send you a packet of the powdered bark, that you may try it in catarrhs and bowel complaints, as a poultice to hasten the maturation of boils, and as a wash in inflamed eyes.—*J. Mease. Philadelphia, Nov. 1. 1839.*

Pópulus græca.— In the *Arb. Brit.*, vol. iii. p. 1651., you say: "According to the *Now. Du Hamel*, it is stated by some to be a native of North America, and more particularly of a township there named Athens." There are eleven post towns in the United States dignified with the name Athens, and doubtless others, with several townships (as I know). The tree may have obtained its name from growing abundantly at a village on the Mississippi called Athens, as unlike the Athens of old as possible. I presume this tree was introduced into the Atlantic States from the West; but when, and by whom, I am

unable to say. Thirty years since, being a novelty, it was extensively planted in lawns in the country, and in cities; but has for some years ceased to be a favourite, owing to the brittleness of the limbs, and the nuisance of the cottony substance discharged from the bursting catkins, which covered passengers in the streets, and filled the chambers in their vicinity, if the windows happened to be open at the time. The limbs also grew straggling and irregular.—*J. Mease. Philadelphia, Nov. 1. 1839.*

ART. IV. *Kew Gardens.*

SINCE the appearance of our article on Kew Gardens (p. 183.), we have received a number of communications on the subject, and we have also taken notice of what has passed in the Houses of Parliament. The subject was brought forward in the House of Lords by the Earl of Aberdeen, and there elicited a declaration on the part of government that there was no intention of destroying the gardens. We wish we could state something equally satisfactory as to the manner in which they are in future to be kept up, and this we may probably be enabled to do at no distant period.

Among other letters and rumours which have reached us, we give the following, which we consider on good authority. Mr. R. Gordon, secretary to the Treasury, stated to the writer, that, "in consequence of the very unsatisfactory state of Kew Gardens, the government, some time ago, directed Dr. Lindley, together with two eminent gardeners, to examine and report upon them, making such recommendations as occurred to them. They made a long report, offering many suggestions, which would have involved an expense of 5000*l.* or 6000*l.* per annum, instead of 1700*l.* (I think, as at present). Mr. Gordon then, on his own responsibility, without consulting the government, begged Dr. Lindley to ascertain whether, if the Horticultural Society had the offer of the gardens, they would accept it, keeping them up in conformity with the recommendations of the report, and allowing free access to the public. This enquiry was construed by Dr. Lindley as a definite offer on behalf of the government, and thence arises the misunderstanding on the subject. Mr. Gordon assures me that nothing will be done at present, nor at any time, without full opportunity for previous enquiry by the House of Commons."

It is stated in another communication, that Mr. Hume proposed, in the House of Commons, "that an annual grant should be made for the support of Kew Gardens as a national establishment, and that they should be under the management of trustees, in the same way as the British Museum." This plan seems approved of by most of our correspondents; several adding, that a national botanic garden forms an essential part of a national museum, and they refer to the Museum of Paris with its National Garden, &c. Several writers deprecate the idea of having a garden director to Kew; they state that two eminent professors have already applied for it: and they strongly recommend that government should save the expense of a general director, to whom not less than 500*l.* or 600*l.* a year would be given, besides a house, &c., by giving the general management of the garden to the president and council of the Linnæan Society, with a paid clerk at the garden, and a curator; recommending for the latter the present botanic gardener, Mr. Smith. We have received various other suggestions, some of them contradictory to the above: such, for example, as one which states that the plants in Kew Gardens were offered to the Royal Botanic Society, of the Inner Circle, Regent's Park, about three months since, by the Earl of Surrey. Mr. Iliff, an eminent botanist and patron of horticulture, states (*Lambeth Argus* for Feb. 29., p. 69.) "that petitions from the Royal South London Floricultural and other Societies are in forwardness, to urge the Lords of the Treasury to place Kew Gardens on a firmer foundation, rather than to allow so base a destruction as has been contemplated."

THE
GARDENER'S MAGAZINE,
MAY, 1840.

ORIGINAL COMMUNICATIONS.

ART. I. *Descriptive Notices of select Suburban Residences, with Remarks on each; intended to illustrate the Principles and Practice of Landscape-Gardening.* By the CONDUCTOR.

No. 15. KINGSBURY, THE RESIDENCE OF THOMAS HARRIS, ESQ.

KINGSBURY, which is situated on the Edgware Road, near the village of that name, may be described as a grass farm, the grounds of which have been ornamented by plantations of select trees and shrubs, and the house enlarged by additional rooms. To one of these rooms a large conservatory is attached, and with this conservatory is connected a series of green-houses and hot-houses, containing, as is well known, one of the finest collections of plants in this country, managed by Mr. Beaton, one of our first botanical gardeners. To a person accustomed to live in the confined limits of a London street house, it is a great luxury to get possession of a group of farm buildings, where there is ample room to make additions on every side. The secret of enjoying this luxury consists, in a great measure, in adding, rather than in altering; because it may be laid down as a fundamental principle, that it is quite impossible to get all the advantages of a new house by altering an old one. Any old house, however, that is not in a state of decay, may be rendered comfortable and commodious (though not well arranged) by additions. When these additions are made under the direction of an architect of taste, very picturesque effects may frequently be produced: but there are not many architects, of the old school, at least, who understand how this is to be managed; in short, how the additions to an inelegant house may be made elegant, and the effect of the whole group, however irregular, rendered symmetrical. This is not the place for going into details, but we shall do this so far as to observe, in order to give an idea of the data on which we found our opinion,— 1. that no object, either in nature or art, can be truly beautiful that is not symmetrical; 2. that there is a regular symmetry, and an irregular symmetry, and that all picturesque assemblages belong to the latter class; 3. that every symmetrical object consists of three parts, the centre or axis, and the sides; and, 4. that in assem-

blages of low buildings, such as those of a farm-house and offices, where the sides are given and the axis is wanting, it may be supplied by an Italian or other tower, campanile, or clock turret.

For an irregular assemblage of objects to be rendered symmetrical, it is not necessary that the tower or other object which forms the axis should be in the centre: on the contrary, it will generally effect the intended purpose better if placed somewhat on one side; because, in that case, the idea of regular symmetry is not raised up in the mind. The spectator does not think of comparing one side with the other, to see if they agree in form as well as in general bulk, but he looks to see whether the one side is balanced by the other, either by bulk, by height, or by distance. Suppose, for example, a group, in which, close by the left of the axis, there are a number of high buildings crowded together, and but very few buildings on the right, and those quite low: in what manner is this group to be rendered symmetrical? By the extension of the low buildings, on the right, so far as to produce by extension on that side, what is produced by bulk and compactness on the other. Whatever is symmetrical, must have a decided axis of symmetry; either obvious, as when a tower rises from a straggling mass of low buildings; or disguised, as when the buildings of a group arrange themselves so as to be included within a pyramidal or conical outline. An axis can frequently be given to a group of trees and buildings by tall narrow trees, such as the Lombardy poplar; but, in such cases, the buildings can never form the main feature in the landscape. These remarks are intended to hint at the proper mode of making the most of old houses in the country, which, from extensive experience and observation, we can assert ought seldom or never to be altered within, though they may generally be added to without, to an unlimited extent.

The remaining part of this article being in great part written by the gentleman who accompanied us through the houses at Kingsbury, we shall place it in inverted commas.

“*March 25.* — The plants here are looking as well as can be expected, after such a long, sunless, damp winter. Frosty winters are always better for house plants, and for all kinds of early forcing, than mild winters, like the last, without sun. The greater portion of the camellias at Kingsbury were forced last May, in order to finish their growth, and set their buds. They were kept in the house all the summer, and began flowering about the beginning of December; and they are now past their best. A few that were not forced, and were out of doors all summer, and in cold frames during winter, are brought into the camellia-house in succession, from the end of January till April. These carry on the blooming season till May. In a large col-

lection of this popular shrub, many are annually to be found with few or no blossom buds, especially when young, and in a vigorous state of health. These are selected here, and put in among the stove plants early in March: their new growth is finished in six weeks; and, by the end of May, they have set their blossom buds. These plants are kept in doors all the summer, and come into flower in October and November; thus keeping up a constant bloom for six months. They are found to be as accommodating in the stove as ferns, living and thriving well under the shade of other plants; and, like the vine, and some other excitable plants, they are found to vegetate early next season.

“The old white camellia, the *fimbriàta*, Lady Hume’s, and *imbricàta*, are well known to be the finest-shaped flowers in this genus, which is now composed of nearly 400 varieties and species. Of all the new varieties, Mr. Beaton thinks the *imbricàta álba* is the most perfect flower; he even says that it is often more perfect than the double white, with occasional broad stripes of red in some of the petals, like a fine carnation. The King is a variety much praised lately; it is in the shape of *pæoniafòra álba*, and mottled like Gray’s *Invincible*; and, in the opinion of Mr. Beaton, only a third-rate flower. *Triúmphans* is a noble flower, bursting out in the centre like the old cabbage rose, and something near the same colour, with pure white blotches. This variety, like *Woodsii* and a few others, requires more heat to expand its blossoms than is usually safe for the others; and it ought to be kept in the warmest end of the house. *Donklæeri* and *trícólor* are great favourites here: several plants of each of them are now finely in bloom, with many others of the newer sorts.

“The *corræas*, which are great favourites with Mr. Harris, are in bloom from September to June, by being forced at different times to make their young growth in the same way as the camellias; and the Chinese azaleas are just ready to expand their flowers under similar treatment.

“One feature in the management of the climbers for the conservatory deserves particular notice. The orchidaceous house is at the back of the conservatory. The *Combrètum purpùreum*, one of the very finest of stove climbers, and others, are planted out in the borders of the orchidaceous house, and in the summer time their shoots are introduced into the conservatory through holes in the top of the back wall, and trained over the rafters, where they flower all the summer, and are pruned close and taken back into the orchidaceous house for the winter. Mr. Herbert wrote to Mr. Beaton lately, to say that he adopted this system at Spofforth with complete success, and that he kept the top of the *Combrètum purpùreum* in the conservatory last

winter, and, though very near the glass, it was not in the least hurt by the frost. *Beaumóntia grandiflora*, treated in this way at Kingsbury, looks now as well as if it were in the hottest stove; and Mr. Beaton thinks this long rest may induce it to flower next summer. It is well known to be one of the most difficult plants to flower. If this experiment does not succeed, Mr. Beaton intends to take it back to the stove for the growing season the following summer, and, after making its growth, he will introduce it again to the conservatory to winter. If this should fail, he will cut it away altogether. Mr. Beaton thinks all the stove passion-flowers might be flowered in the conservatory or green-house on the same principle; but the beautiful *P. kermésina*, for this purpose, and indeed for all purposes, ought to be inarched on some of the stronger-growing kinds. It would even be worth while to inarch it on any hardy passion-flower already in the conservatory, the head being introduced into the stove for the winter. A plant of this species grafted in one of the stoves on the *P. alata* covers many square yards, and has not been without blossoms for the last eighteen months; and in summer this plant is covered with hundreds of blooms at a time. Mr. Beaton thinks *Bignónia venústa* would do admirably treated in this manner; and regrets that this, and such plants as *Allamánda cathártica*, the petreas, *Cómbrètum purpureum*, and such like old substantial good climbers, should be so much neglected, to make room for others which have only novelty to recommend them. He also regrets the present rage for *collections*, when *selections* would answer all the purposes of private collectors so much better. But to return to climbers: the half-hardy, or conservatory, climbers are here treated on the same principle as the stove ones. These are planted out, as all climbers ought to be, in the front border of the conservatory; and, about the end of May, are taken outside through a pane of glass in the bottom of the roof-sashes, and trained outside for four or five months, to make room for the introduction of the stove climbers. They are close pruned in October or November, and taken back to the conservatory for wintering. *Tacsònia pinnatistípula*, one of the very best conservatory climbers, treated in this manner, covers a great space in a short time, flowers abundantly in the open air from July till Christmas, and stands ten degrees of frost without any injury. Mr. Beaton calls this plant one of Sweet's fanciful genera, which, he says, are only genera by name, not by nature.

“If Mr. Beaton were compelled to grow only three kinds of conservatory climbers, the *Tacsònia* would be the first he would choose; and yet it is hardly to be seen anywhere.

“The new *Wistària* from Moreton Bay, of which Mr. Beaton gave an account in the preceding Volume (p. 400.), is growing

rapidly in the conservatory, and in the coldest end of the greenhouse; but the one planted out against a south wall died this winter. It has been growing in the greenhouse all the winter, from which we may reasonably conclude that it is an evergreen. It will not flower here this season; at least, it shows no signs of flowering yet.

“Among the stove plants are many large specimens. Two fine plants of *Ardisia paniculata* are now in full bloom; two of the finest specimens in England of that good old plant *Jatropha panduræfolia* are just beginning to show their splendid flowers, and will be in flower every day till the end of next October. After flowering, this plant is kept perfectly dry for three months. It seems a great favourite here: we observed plants of it in all stages of growth, from 6 in. to 3 or 4 feet high; some as standards, others as dwarf bushes. Several species of *Theophrasta* make a fine appearance at this time, with their large handsome foliage, for which they are chiefly grown. *Inga Harrisii* will soon be a splendid object; it is literally covered, from top to bottom, with blossom buds: it belongs to the deciduous class of shrubs, casting its leaves in winter; and the flowers and young foliage appear at the same time. Another valuable plant for private collections, *Clerodendron phlomoides*, has been in flower here since April, 1839. A cut specimen of it, in flower, was exhibited then at the Horticultural Society's Rooms in Regent Street, when it was reported to be nearly as sweet as a jasmine. It is a half-climbing plant, with abundance of terminal racemes of flowers, similar to those of *C. hastatum*, with neat small foliage, and, what is strange in this genus, the plant is never attacked by any kind of insects. It delights in the hottest part of the stove. It was among the last lot of plants sent over to this country by the late Dr. Carey, and, we believe, at the request of Mr. Herbert. It is only in one or two other collections, to which Mr. Harris presented it. Speaking of Dr. Carey, we saw here, for the first time, that fine myrtaceous plant named after him by Roxburgh. It is something in the way of *Barringtonia speciosa*, but deciduous. The genus *Carèya* is closely allied to *Barringtonia* and *Gustavia*. These three plants, with *Magnolia*, are noble plants to commemorate such names as Daines Barrington, Gustavus the Third of Sweden, Dr. Carey, and Dr. Magnol of Montpellier. We noticed more than half a dozen fine *barringtonias*, *ixoras* in abundance, a fine plant of *Brównea grandiceps*, the cow tree of Humboldt, and one of the finest specimens of *Strelitzia júncea* which we remember to have seen anywhere. In the greenhouse are some good specimens of *Boronia serrulata* in flower; also, a large specimen of *Scóttia dentata*, several heaths, *epacrises*, *chorozemas*, *eutaxias*, and such like plants; also, a large *Rhododendron altaclerense*

in full bloom; and, what rather surprised us, half a dozen fine specimens of that gay and very scarce plant *Lálage ornàta*, a genus of which only one more species is known to botanists. Seeds of this lalage were brought over from Australia to Mr. Knight, by the late Mr. Baxter, in 1829; and, under Mr. Knight's superior management, it was flowered in 1833 or 1834, and afterwards figured in the *Botanic Register*. It was found to be so difficult to propagate, that fears were entertained of its being lost to the country altogether. We heard nothing of it for the last three or four years, and thought it was really lost. Mr. Beaton tells us the original plant is still in the Exotic Nursery, where plants of it may be had, and also at Clapton, and probably in some other nurseries.

“Along the front stage in the green-house we noticed a collection of new Australian seedlings. Some of these were raised here; the rest is the cream of the large collection raised last year in the Clapton Nursery, from seeds sent to Mr. Low: these were received in exchange for a beautiful *corræa*, raised by Mr. Beaton at Haffield. (See our preceding Volume, p. 94.) This *corræa* Mr. Low thinks far superior to any of the new seedlings; and we believe a figure of it will soon appear in Paxton's *Magazine of Botany*. There are many other cross seedlings of *corræas* and other plants in progress here, which, as soon as they are proved, will soon find their way into other collections. Mr. Beaton has been for many years trying to prove Mr. Knight's theory of vegetable superfœtation, and promises (p. 161.) to send us an account of his failures. But he says, on reviewing his notes, he finds the action of the pollen in some instances so very different from what it is generally believed to be, that he shall put off saying anything on the subject till he sees how far this difference takes place in different genera or families. Our readers will recollect what Mr. Beaton wrote on the crossing of fuchsias in a former volume. We here saw what Mr. Beaton calls the most curious cross yet obtained among the fuchsias: it is a seedling from *F. arboréscens* fecundated by the pollen of *F. excorticàta*. It is nearly four years old, and has shown no disposition to flower. The parent plant is upwards of 12 ft. high, and beautifully branched. Mr. Beaton dusted many thousand flowers of *F. arboréscens* with the pollen of different fuchsias, and raised many thousand seedlings from plants so dusted for several successive years; but this single instance is the only deviation he found from the *arboréscens*. When this cross and the other splendid crosses from the *F. fúlgens* will come to interbreed, they will raise the character of this favourite family far beyond what we have any conception of now.

“The many importations of orchidaceous plants, from Mexico and the north-east parts of South America, have filled the

orchidaceous house here to suffocation. The cultivation of so many newly received plants, requiring a different treatment from established plants, prevented Mr. Beaton from following out Mr. Wailes's suggestion on the atmospheric temperature and moisture in the orchidaceous house. He highly approves of Mr. Paxton's mode of growing *Dendròbia*, and other similar plants. Some of these plants here begin to show blossom buds in a week or ten days after taking them into the orchidaceous house from their winter quarters. Mr. Beaton maintains that no extensive collection of this order can be kept for any length of time in a fine flowering condition without the use of two houses; the second house to be kept quite dry and cool; and the plants, while resting here, to be kept exposed to the full rays of the sun. There are many new and undescribed species here, particularly among the Mexican Orchidacææ.

“The *Cácti* have been more than doubled since we saw them last season, and many of the specimens are not to be equalled anywhere. Mr. Beaton has arranged his seedling *Cácti* on a front shelf, in sections, just to our taste; and his experience has even enabled him to follow out this plan farther than science could do. He places all his melon-shaped *Cácti*, which require more heat, in the hottest end of the shelf. Many of this section, in a young state, can hardly be distinguished from each other but by a practised eye. These are here planted out on this shelf, on a layer or bed of sandy compost over slabs of slate, in rows across the bed; and, where each kind terminates, a row or two of upright seedling cereuses, which require strong heat, are placed after each kind of melon-shaped *Cácti*. The seedlings of those *Mammillariæ* found in the low hot valleys of the tropics follow after the *Melocácti* and *Echinocácti* seedlings; and, at the coldest end of the shelf, they finish with such *Mammillariæ* as are found on the hills and high ridges, and require less heat. Altogether, this appears to us the most interesting shelf of *Cácti*, and the most scientifically arranged, in this country. Here is the largest plant of *Euphòrbia jacquiniaeflora* that we have seen, now covered with its rich deep orange blossoms: when out of flower, it must look like a young vigorous peach tree; and, being trained after the manner of peach trees, the illusion is heightened. Nothing can exceed the splendour of *Euphòrbia splendens* at this time, just beginning to put forth its new leaves, and literally in one mass of bloom. Several large specimens are here now in this state, one of which is perhaps the largest in the country. By the side of these stands a fine specimen of *Euphòrbia* [j.] *Briòni*, a nearly allied sort, smaller than the preceding in all its parts, and more fastigiate in habit. Both these kinds seed freely, especially towards the end of the blooming season (July and August);

and, notwithstanding their seeming relationship, Mr. Beaton has hitherto failed to obtain a cross between them. In another house we noticed a standard of that fine old plant the *Euphórbia phœnícea*, with a head 4 or 5 feet in diameter, and just coming into bloom. There is also a good stock of mesembryanthemums, aloes, and the common epiphyllums, in another house appropriated to this section of plants. The day being very cold, we did not see much of the plants in the pits. These pits, and some of the houses, are heated by Rogers's conical boilers; and also a long shed in the farm-yard, with glass sashes in front, where rare specimens of single camellias, acacias, and such-like plants are wintered, to be turned out in summer into the flower-garden, and other convenient places round the house. The subsoil here is so cold and damp, that it is found necessary to take up in the autumn such plants as *Benthàmia fragífera*, *Gárrya ellíptica*, and many other half-hardy plants, which are kept in this shed conservatory all the winter.

“A large number of apple and pear trees were planted here this spring. The pits for these were from 4 ft. to 5 ft. in diameter, and paved with common slates, their edges lapping over each other, as in common roofing. Prepared compost was filled over these slates till it was 6 or 9 inches above the common level of the garden, and the trees planted on these round hillocks, and mulched all over with a compost of rotten dung, rotten tan, and about one third of sifted coal ashes. The trees were bought at Mr. Forest's nursery, Kensington; and, though Mr. Forest is an entire stranger to Mr. Beaton, the latter thinks it but justice to say, that these fruit trees were the finest he ever saw coming out of any nursery whatever.

“All the paths in the houses are of Welsh slate, half an inch thick, which is found far cheaper and more durable than stone pavements; besides, there is no dust from them like that from stone paths. Many of the shelves are also of this slate; but, for this purpose, the slate ought to be ribbed, in order to carry off the drainage from the bottom of the pots more effectually, and to be drilled with small holes to let through the wet from the furrows formed by the ribbing. In one division of a range of low houses are some fine pine-apple plants, which never had any bottom heat, and nothing can exceed their vigour and healthy appearance. They are plunged in old tan, and an empty pot placed, mouth upwards, under each pine pot. The water from the pine pot passes down freely into this pot, and the worms are never found to get into the pine pot. If the lower pot were placed bottom upwards, the drainage from the pine-pot would not be complete, nor the worms kept back. When bottom heat is used for pines or other plants, this is always a safe mode to guard against too strong bottom heat.

Indeed, Mr. Beaton thinks that no pot should be plunged in any cold or hot medium, in or out of doors, without first taking the precaution to place an empty pot under each pot; and the only thing to be attended to is, to have the mouth of the lower pot a little narrower than the bottom of the pot to be placed over it. This plan was shown and first recommended to Mr. Beaton by Mr. Thomson, of the Horticultural Society's Garden, one of the most scientific gardeners with whom Mr. Beaton is acquainted."

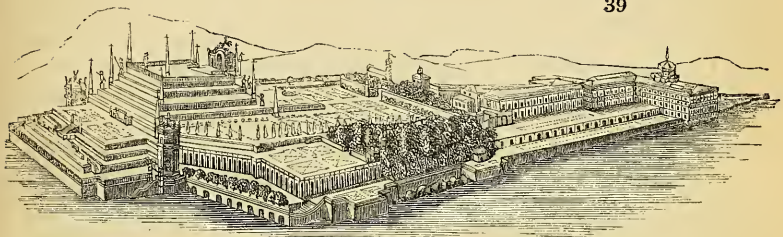

Isola Bella.

ART. II. Notice of the Plants which grow in the open Air in the Borromean Islands (*Isola Bella and Isola Madre*) in the Lago Maggiore. By Signor GIUSEPPE MANETTI.

VEGETATION in these two islands is wonderful, and bespeaks the fertility of the soil and the mildness of the climate. In summer they are cooled by the breezes of the lake, and in winter the usual temperature ranges from zero to two or three degrees below it; or if it is sometimes a little lower, it is for a few minutes at twilight, and then it never falls so low as 5° Reaum. In *Isola Bella*, however, which is nearer the mountains than *Isola Madre*, the temperature falls generally a degree or two lower, according to the prevalence of wind. The soil is calcareous, containing a little clay (*argilla*) and mica, which gives it a shining appearance in the sun.

The trees which in the following list are marked with an asterisk grow in both the islands; and those not marked, only in *Isola Madre*.

Acacia farnesiàna, *A. acanthocàrpa*, *A. latifòlia*, *A. longifòlia* 20 ft. high, *A. vèra*. *Acer oblongum*. *Agapanthus umbellatus*, *A. umb. variegatus*. **Agave americana*, **A. amer. picta*. *Amaryllis formosissima*. *Anthyllis Bárba Jòvis*. *Araucaria brasiliàna* 14 ft. high, diameter of the head 10 ft.; *A. Cunninghamii* 14 ft. high, head 12 ft. in diameter; *A. excelsa* 16 ft. high, head 10 ft. in diameter. I was delighted with the effect of these three plants; I send you a drawing of the last species. **A'r-*

butus *Andràchne*; *A. gláuca*?; *A. procèra*; *A. U'nedo* 18 ft. high, and occupying a space 20 ft. in diameter; *A. U'nedo críspus*; *A. U. integrifólius*; *A. U. latifólius*. **Aristotèlia Mácqui*. *Azàlea índica*, thirty varieties. *Báccharis halimifólia*. *Bánkisia latifólia*. *Bérberis empetrifólia*. *Búddlea globòsa*, *B. salviaefólia*. *Callistèmon cítrinus*, **C. lanceolátus*, *C. ruscifólius*?, **C. salígnus álbus*, *C. rugulòsus*. *Caméllia japónica atrorúbens* 16 ft. high, *C. jap. pink* 18 ft. high, *C. jap. rubra máxima* 12 ft. high, *C. Sasánqua* 16 ft. high, and various other varieties of *C. japónica* from 8 ft. to 12 ft. high. **Cápparis Breýnia*. *Ceanòthus azùreus* 14 ft. high. *Cèreus flagellifórmis*. *Ceratònia Síliqua*. **Cestrum Párqui*. **Cinerària platanifólia*. **Cinnamòmum Cámphora* 50 ft. high, the stem 1 ft. in circumference. *Cistus ladaníferus*. *Cítus Aurántium*, *C. Limònum*. *Clèthra arbòrea*. *Coronílla valentina*. *Cunninghàmia sinénsis* 40 ft. high, head 20 ft. in diameter. *Cuprèssus austràlis*, *C. passerinòides* (? *dísticha nútans Arb. Brit.*). *Cýclamen pérsicum*. *Cýcas revolùta*. *Dáphne híbrida*, *D. odoràta*, *D. variegàta*, *D. oleifólia*. *Dablías*. **Edwàrdsia microphýlla*. *Elæágnus argétea*?. *Embóthrium salicifólium*. *Erica arbòrea* 12 ft. high, *E. capitàta*, *E. mediterrànea* 10 ft. high, *E. multiflòra*, *E. polytrichifólia* 12 ft. high, *E. spùria*. *Eucalýptus nòva spècies* 16 ft. high. **Euónymus japónicus*, *E. jap. fòl. aúreis variegàtis*, *E. jap. fol. argéteis variegàtis*. *Freylínia speciòsa* (? *Búddlea glabérrima Lois.*). *Gnídia símplex*. **Gordònia Lasiánthus*, **G. pubéscens*. *Gortèria rìgens* (*Gazània rìgens*). *Gaulthèria Shállon*. *Hàkea pinifólia*. *Hallèria lúcida*. *Juníperus bermudiàna*, *J. capén-sis*. *Justícia Adhatòda*. *Ixia fenestràta*. **Laúrus nóbilis* [mentioned in our Volume for 1839, as being 62 ft. 10 in high, and of which *fig. 40*. is a portrait reduced from a drawing kindly sent us by Signor Manetti. The remains of the letter N cut on the bark of this tree by Napoleon are still seen]. *L. índica*, *L. tomentòsa*. *Leonòtis Leonùrus*. *Leptospèrmum ambíguum*, *L. speciòsum*, *L. tomentòsum*. *Ligústrum lúcidum*, *L. nepalénse*. *Lyttæa geminiflòra* in full flower, last year (1839) the scape was 22 ft. high. *Magnòlia fuscàta* 10 ft. high, the space occupied by the branches is 10 ft. *Meni-*

40



spérmum laurifòlium. *Mesembryánthemum aúreum*, *M. stellátum*. *Myrica cordifòlia*. *Nandina doméstica*. *Nerìne undulàta*. *Nèrium Oleánder*. *O'lea excélsa*; **O. fràgrans* 14 ft. high, and the space occupied by the ramifications 12 ft. in diameter; *O. sinénsis*, I think this is a variety of *O. fràgrans undulàta*. **Opúntia cochinillifera*. **Ficus índica*. *Othónna cheirifòlia*. **Panax aculeàta*. *Petróphila pulchélla*. *Phórmium ténax*. *Pinus nepalénsis*, **P. palústris* (austràlis) 30 ft. high. *Pittósporum Tobìra* 16 ft. high, the space occupied by the ramification is 16 ft. in diameter. *Podocárpus nucíferus*. *Raphiólepis índica*, *R. rùbra*. **Rhododéndron arbòreum*, and thirty varieties. *Ròchea falcàta*. *Sálvia nóbilis*, ? *S. pulchélla*. *Thèa Bohèa*, *T. víridis*. **Vibúrnum sinénse*. *Yúcca aloifòlia*, *Y. dracònis*, *Y. drac. marginàta*. *Zàmia hórrida*. Besides these plants there are beautiful groves of *Rhododéndron pònticum* and *máximum*, with an infinity of varieties of azaleas, andromedas, and kalmias. *Dáphne collùna*, *Clèthra alnifòlia*, *Mahònia Aquifòlium*, *M. fasciculàris*, *M. rèpens*. Myrtles. *Rìbes sanguíneum*, *R. sang. angústum*, *R. sang. malváceum*, *R. speciòsum*. A fine *Laúrus caroliniàna* 16 ft. high. A *L. Sássafras* 32 ft. high, and the stem 1 ft. 3 in. in diameter, being the finest I have hitherto seen. A *Magnòlia cordàta* 40 ft. high. *Quércus Súber* 24 ft. high. *Cèdrus Libàni* 80 ft. high, and 2 ft. diameter in the stem. A *Photínia serrulàta* 16 ft. high, and the space occupied by the branches 18 ft. In the flower borders are cultivated beautiful species of annual and perennial plants of recent introduction, such as *Schizánthus*, *Collòmia*, *Viola trícòlor*, *V. grandiflòra*, *Gília*, *Ipomópsis élegans*, *Phlòx*, *Galárdia*, *Verbèna*, &c.; and more than 130 varieties of *Chrysánthemum*, all obtained by the diligence of that excellent gardener Renato Rovelli, who knows so well how to second his illustrious master, Count Vitaliano Borromeo, in the love of botany, who spares no expense to embellish and enrich his two fine estates with rare plants.

Monza, near Milan, March 19. 1840.

ART. III. *Some Thoughts on the Effect of Shadows in Garden Scenery.*
By R. W. F.

WHEN the broad shadows of full-foliaged trees fall upon a rising ground, the extent of the ground is apparently increased; for example, in the view of the long walk at Windsor, as given in Heath's *Picturesque Annual* for 1840.

It has always appeared to me when looking up an avenue, even one which only slightly rose to the entrance of the house, that the distance between the spot on which I was standing and the entrance seemed to be increased by the shadows of the trees

which fell athwart the road or path. To those who have been in forests, or have seen accurate delineations of them from nature, the alternations of light and shade in irregular masses is, I think, well known to augment to the eye (for I think it after all a deception) the actual distance of objects situated on the horizon. This appears well known to artists, who certainly employ a breadth of light or shade in their paintings which imparts the appearance of extent to the view portrayed; or at least mainly contributes to the production of such an effect. At the same time, detached shadows render the picture "spotty," and less extensive.

I shall, however, probably be told that a continuous line gives a greater idea of length, than one which is broken by any object or objects as shadows; and that a lady who wears a gown with a striped pattern lengthwise will look taller than if the pattern were made to go crosswise or round the person. But I believe that the eye rests upon each shadow, lingers upon each in going round it or tracing its outline, and consequently does not so soon reach the horizon; the idea of extent being created by the time occupied by the eye in going over the whole.

What I state is, I think, most applicable to length: so, in a glen, for instance, dark masses of shade alternating with the rich glow of a sunset give, I cannot help thinking, a greater extent of scenery, as it were, to the eye. Remove the bounding objects, the hills, and I think this effect will be materially diminished. I think also that this appearance of increase of surface is somewhat more evident in positions where the eye has to be elevated a little to gain the horizon. Need I allude to a similar effect produced on scenery by the lengthening shades of evening:—

"Majoresque cadunt altis de montibus umbræ."

VIRGIL. *Ecl.* 1. ver. 84.

The lofty mountains throw a larger shade.

Watford, March, 1840.

ART. IV. *On the Preference for Scotch Gardeners.* By J. WIGHTON, Gardener to the Earl of Stafford, Cossey Hall.

SCOTCH gardeners are often preferred in England, as if they had a better knowledge of their profession than English gardeners. As gardening is certainly as well understood in England as it is in Scotland, it may be worth while to enquire into the cause of this preference; and also the reason why so few young men in England, after serving a regular apprenticeship as gardeners, ever arrive at the head of their profession. They remain only a step above a common labourer, and seldom remove from the place of their birth; while most young men who

learn gardening in Scotland become in time head gardeners, either at home or abroad. Various reasons are assigned why the preference is given in England to Scotch gardeners: one is, that they are usually better educated; another, that the greater coldness and changeableness of the climate of Scotland obliges the gardener to take greater care and pay more attention, which renders him more skilful in his business; another cause assigned is, that Scotchmen are generally a more steady and calculating race. However well founded these reasons may appear, they are not sufficient to account for the decided preference given to the Scotch gardener. Education can do but little where there is deficiency of natural abilities; and, though Scotland is colder than England, the English gardener has quite enough of coldness and variableness of climate to call forth his energies. If the Scotch are more cool and calculating, they must acquire those habits by early training.

It is probable that the Poor Law system in England has had the greatest share in producing the superiority of the Scotch over the English gardener. It mainly depends on the difference of training, when acquiring the knowledge of his business. In England, the mansion and gardens of the wealthy are more frequently situated adjoining a populous village; the proprietor, in consequence, often finds his property burdened by too many labourers. When his gardener wants an apprentice, his employer obliges him to take one who belongs to the parish; as he cannot think of employing strangers. The young man chosen begins with the honest intention of becoming a gardener, and has at first, probably, an anxious wish to learn. But this too often cools, from associating with others of his native place, who are not gardeners.

His attention is much taken off by such connexions, and he is less disposed to give his mind wholly to gardening, if his parents are, as it usually happens, of the agricultural class; because he shares in their ideas and feelings, and especially in the notion that he must be employed, because he belongs to the parish. If, however, he escapes these evils, when the time of his apprenticeship is expired, he finds it difficult to procure a situation as under gardener, on the same principle that caused him to be chosen for an apprentice, namely, his not belonging to the new parish where he makes application. This forms a serious obstacle to the advancement of young gardeners, and is the greatest cause why so many never remove from their native place. Seeing the difficulty of procuring a situation elsewhere, they grow indifferent about advancement, and give up all thoughts of becoming master gardeners; after a time they marry, and settle down for life in the place where they were apprenticed.

In Scotland, the residences of the wealthy are less frequently situated near a populous village; and the proprietor does not find his property overburthened with labourers. He often leaves his gardener to choose his own apprentices; as it matters nothing whether he employs a native or a stranger, there being no Law of Settlement to interfere with the labourer's independence. There is a lodge at the garden; and the apprentice is at once placed there, to live with the under gardener. It is curious that these lodges have got the Gaelic name of *Bothies*, there being so few Gaelic words in the Scotch dialect. Being thus thrown from the first upon his own resources, which are slender enough, he learns to think and manage for himself. He has thus every opportunity of learning his business from the gardeners, with whom he constantly lives, and has no village companions to divert his attention. At the expiration of his apprenticeship, he knows that he must seek a situation as a journeyman gardener elsewhere, as it is unusual to remain in the same place. This cuts the taproot of his connexions. By serving in various places for some years as an under gardener, he acquires sufficient knowledge to take the situation of head gardener whenever it offers; and, from being often transplanted, he readily takes root in any clime, though he always retains the love of his own country.

Though these advantages are peculiar to the Scotch gardener, it is not denied that there are many good English gardeners. The greater number of gardeners in England, however, remain little above the common labourer, in consequence, no doubt, of the evil operation of the Law of Settlement; and, though this part of the law has been lately abolished, the alteration will not soon produce an effect in those parts which are thickly inhabited. It may be observed, in conclusion, as a proof that there is no want of ability in the English gardeners, that those young English apprentices who are trained under Scotch gardeners in England, are no way different in their habits and fortunes from those who are apprenticed under English head gardeners.

Cossey Hall Gardens, January 21. 1839.

ART. V. *On the Utility of Draining; with some Methods adapted for various Soils.* By JOHN FISH.

THE first and principal improvement of wet land is draining, without which the greatest quantity of manure, of whatever description it may be, will prove ineffectual towards its productiveness.

Soil overcharged with moisture, proceeding from the water being retained by a stiff impervious clay, or from cold springs,

which are frequently loaded with minerals and acids, not only proves injurious to vegetation, but also, from the evaporation of their aqueous particles, tend to corrupt the atmosphere. Some plants require a greater, and some a less, proportion of water in their food. Those in general cultivation are of the latter description, and are easily injured by an excess of moisture. Hence water may be regarded as an impediment to vegetation; and therefore it becomes a matter of importance, to consider the most proper methods of conveying it off all soils where it is superabundant.

No regular system of draining can be given, as our plans and operations must be regulated by the circumstances we are placed in; for it is not with the earth, as with the animal body, whose component parts form a regular system, and whose fluids circulate in known channels. The circulating fluids in the earth are conducted by circumstances altogether different, and frequently in channels the most complex and intricate; the variety of cases may be said to be innumerable, no two pieces of land being perfectly alike.

The first consideration should be the nature of the soil and subsoil, whether it is of a retentive nature or not; and also the surface to be operated upon, even or uneven. When those principles have been thoroughly investigated and the cause made clearly apparent, the operator will readily see that no general rule can be applied to all cases, but that the grand and leading feature of this, as well as of most of our operations, is in making them subservient to the end in view. A principal point is, to ascertain the best and most convenient place for the drains' discharging their water, and to mark out the lines before the operation commences. In drainings of every description, two considerations should constantly be kept in view; these are, draining effectually, and at the least expense. These should be the objects of all who engage in this and every other improvement, and cannot be obtained when the work is executed without investigating the cause from which the wetness proceeds, as is evidently too often practised; and proofs are not wanting to show that to this may be attributed the failures we so often see. Not unfrequently has land to be drained a second time, from the operator not taking into consideration the nature of the soil, nor yet the cause of the water.

A wet soil may proceed from one or all of the following causes: — an undersoil of close texture, which will prevent the surface-water from soaking through it; springs bursting out of the earth, and wanting a free current; and frequently low ground becomes saturated with water from the high grounds, through veins of sand, gravel, or fissures of rock; also from want of a sufficient descent, or by an impervious stratum of retentive clay.

The soil, the subsoil, and the base impervious. This is of rare occurrence, and rather difficult to remedy; as in this case, rain-water being unable, after the soil is saturated, to penetrate the surface, thus precludes, in a great measure, the art of draining. As our operations in this case will be confined to the surface, where the base is of great depth, the effects of this on vegetation are soon apparent; the soil having been saturated by the rains of winter, and expanded by frost, and its fresh pores probably filled with dissolving snow, and having no other means of discharging its superfluous moisture but the process of evaporation, its efforts are checked, and its power of vegetation retarded.

In the cultivation it is difficult to work, and cropped with uncertainty, from its liability to close upon the roots of the plants, depriving them of the necessary supply of air, and thus materially injuring their growth. This description of soil may be remedied considerably by rounding it in ridges, with open interfurrows, cross drains, and ditches; thus taking off the superfluous rain or surface water, and conveying it to some desirable place.

First, I shall commence with covered drains. Their dimensions will depend upon their depth, the quantity of water they have, or may be wanted, to carry, and the materials they are filled with. When the depth does not exceed 3 ft., 1 ft. 3 in. wide at the top will be sufficient; but, when deeper, the width may be increased to about 3 in. for every foot in depth: the width at the bottom to be also attended to; it should not be much narrower than the top, to allow of building a substantial drain; if this is not attended to, unpleasant results may follow. When the bottom is made (as it frequently is) much narrower than the top, the stones are obliged to be set on their edges, and the covers laid on them in an insecure state; and in many instances they fall down before the drain is finished, to the mortification of the operator, by which springs would be formed in the driest part of the ground.

In making drains, several things might be done as a means of facilitating the operation: — the stones to be laid in readiness for commencing; the excavating and the making to go hand in hand, for fear of accidents, such as the soil falling in; great care taken that the bottom of the drains may fall with a regular descent, in order that the water may run from one end to the other without stagnation.

When the bottom is soft, it should be laid with flag-stones, to prevent the materials from sinking; the side walls should also be made secure, and the covers strong, packed at their ends with broken stones; the space above, in strong adhesive soils, should be filled with stone rubble, within 1 ft. at least of the

top surface of the ground, which remaining space should be filled with rough porous soil, thus rendering it a fit receptacle for the dispersion of water from bottom to top, which I consider of much importance, as it tends to drain the ground much more effectually. Before the soil is put in, this stonework should be covered with straw, or, what is better, with turf, with the green side downwards, to prevent the soil from subsiding into the crevices among the stones.

It is necessary to have the mouths of the drains well built, and secured with iron gratings sufficiently close to prevent the ingress of rats and other vermin, as they are found to be destructive, when burrowing in them; they should also be examined, and kept in proper repair, and the outlet kept sufficiently clear, so that the water from the drains may run away freely, otherwise it will remain stagnant in them to the great injury of the soil.

Attention must be paid that they are not carried into the outlet at right angles; their ends should be turned down in the direction the water runs, for a short space before they join it. This should be attended to in all cases of one drain discharging itself into another, as it prevents the water in the outlets from depositing any sediment in their mouths, which would be the case were this not attended to; indeed, it often happens that drains are stopped, and rendered useless, from this precaution being neglected.

Ridge-tiles may be advantageously used for draining, both for removing surface and under water. Spades are made on purpose for digging these drains, just wide enough to let the tiles go easily into them. The tiles should be well burnt, as it is found by experience that hard-burnt tiles will last longer than those that are not; and should be laid on flat tiles, or soles, as they are called, of the same texture, to prevent them from sinking, or otherwise getting out of place.

By proper management, I consider that tiles may be successfully used for draining to any depth, and at far less expense than stone; however, where stone is in abundance, I should recommend it to be used, as being more durable. I have seen tiles used at the depth of 4 ft. filling 2 ft. above them with loose materials, laying another course upon this, and filling up as before. In all cases where they are used, the space above them should be filled, to within a few inches of the surface, with some loose porous substance, otherwise they will not have the desired effect, namely, drying the soil.

Rubble drains are well adapted for removing water confined in porous soils with an impervious bottom, and from an alternate stratum of whatever description; the depth should be proportioned to the nature of the soil and subsoil, which should be

brought to within 1 ft. of the top surface, and, in clayey soils, the remainder filled with a porous earth: they are attended with little expense where stone of any sort can be procured.

Wood faggots, &c., are sometimes used for draining; but, from their liability to decay, thus destroying the drains by the process of decomposition, they cannot be recommended as permanent, although they act well for some time.

In some cases ditches are preferable to covered drains, such as bogs or moss with a soft bottom; for, should stones be used, from their liability to sink, the drain would be rendered useless. Their depth and wideness will depend upon the quantity of water they have to carry, and the nature of the soil and situation: the fall should be such that the water may run off without stagnation. In digging them, the earth thrown out should not remain upon the sides, but be removed to the nearest hollows: if this is not attended to, their use will be in a great measure counteracted, as placing it upon the side is a preventive of the surface water entering the drain; its weight will also have a tendency to make the sides give way.

Hollow earth drains are sometimes used with good results, to collect water from the subsoil, or receive rising water at their base. The method of making them is simply this: dig them perpendicularly to the desired depth, taking out the last spit with a spade 6 in. narrower than the other part. A shoulder, as it were, is thus left on each side, on which some good strong sods are laid, with the grass side downwards. When the water lodges in a stratum of loose earth, the operative part of the drain should be lined with turf, to prevent the sides from falling in, which would otherwise choke up the channel; the joints on each side to be left sufficiently open to permit the water to filter freely.

There is, perhaps, no department of rural improvement on which so much money has been expended to so little advantage as on draining. And why? Because the work is often carried on without at all considering the nature or cause from which the water proceeds. One drain, judiciously conducted, may be as effectual as twenty run at random; and it is the case with many to set to work and fill the ground with drains in all directions, or wherever the least symptoms of moisture appear, while by a single drain, properly directed to the lodgement of the water whose ramifications caused those symptoms, the entire site might have been effectually laid dry.

I have seen instances of this kind, and shall here take the liberty of mentioning one, which occurred at the Earl of Mansfield's, Scone Palace, Perthshire. The soil was of a soft peaty nature, with a subsoil of white tenacious clay, 2 ft. to 3 ft. deep; under this lay a stratum of a sandy nature, which contained the

water. The first attempt proved a failure, inasmuch as the drains were not deep enough to reach the source from which the water proceeded. It being desirable to have this ground in a state for cultivation, an examination took place, and the stratum found which contained the water; then drains were made to the depth required, and the outlets deepened accordingly. This answered completely.

Had the boring auger been first used in this case, it would have saved the expense of a second draining. What would we think of the miner, in search of mineral and fossil substances, commencing to sink his pit without the use of the auger, to ascertain whether what he wanted was there or not? We should be inclined to say, he was working in the dark. The borer may be as advantageously used for finding the reservoirs and channels of subterraneous water, which is of the greatest importance to those who engage in the draining of land.

It is necessary to bore in several places in order to obtain a competent knowledge of the various lodgements of the water, and at the different depths. When these have been ascertained, the next thing to be done is to run a main discharging drain in the lowest part of the field of improvement, and to a sufficient depth to draw off the water from its deepest recess. Sometimes this will be sufficient; if not, another must be made to the next deepest water, and in the lowest situation, in the best line for a fall.

As the object here, as well as from springs, is the carrying off under, not surface, water, it will be unnecessary to fill above the drains with stone rubble, or anything of that nature. When water proceeds from springs, the same method as detailed above should be adopted; namely, the line of draining them should be on a level with the lowermost springs, thus keeping the others in a great measure dry. If a sufficient outfall cannot be commanded to carry off the water, a well may be sunk a little below the lowest lodgement of water, and the water may be raised with a mill, or pump; thus obtaining by art what nature had not accomplished. This is never attempted unless in extraordinary cases, as the expense incurred would not warrant its adoption.

The quality and value of lands depend entirely on the quality of the soils of which they are composed. If these are sufficiently absorbent and open to prevent a surcharge at the feeding fibres of plants, yet sufficiently retentive of moisture to prevent the too rapid escape of rain-water through the plant-feeding system, the land is of superior quality. But if, *vice versâ*, the several strata are of so loose a texture as to permit the rain-water to pass through quickly, without being in a sufficient degree arrested by the soil, it is of inferior quality. Therefore, due precaution

should be taken before commencing an undertaking on which, in a great measure, the success of every branch of horticulture and agriculture depends; and, therefore, it becomes a matter of the greatest importance that every circumstance should be investigated, for the purpose of discovering the cause from which this or that proceeds. That some land may be over-drained, I admit; but this is of rare occurrence, and a remedy soon presents itself; that is, shutting up the mouths of the drains when necessary, and thus forcing the water back whence it proceeded. This may be continued for any length of time, and may prove beneficial in dry seasons. However, I consider stagnant water, in all cases, to be injurious to vegetation; and plants can neither perspire nor luxuriate when saturated with this element. Where surface soil rests on a subsoil moderately porous, both will hold water by capillary attraction, and what is not so retained will sink into the inferior strata by its own gravity; but, when the subsoil is retentive, it will resist water, and ultimately by accumulating it in the surface soil, cause diseases which are detrimental, and would soon prove fatal, to the vegetable system.

Exotic Nursery, King's Road, April 4. 1840.

ART. VI. *Description of a Transplanting Machine invented by James Kidd, Gardener to Lord Kinnaird, Rossie Priory Gardens, Perthshire.* By J. KIDD.

I SEND a miniature model of a machine which I lately invented for the removal of large shrubs, and which, after repeated experiments, I can confidently recommend as admirably adapted for that purpose.

[This machine may be described as a gigantic 5-pronged fork, mounted on a pair of wheels and axle, the latter serving as a fulcrum for lifting up the tree out of the hole formed by digging round it, and, with the wheels, facilitating the removal of the plant to the place of its destination. The length of the axle between the wheels is 2 ft.; the axle 4 in. deep, and $2\frac{1}{4}$ in. thick: the handle, or lever, is 10 ft. long, mortised into the axle; it is 6 in. deep and $3\frac{1}{2}$ in. thick: the prongs are 2 ft. long and $2\frac{1}{4}$ in. deep: the wheels are 1 ft. 4 in. in diameter. All the parts are of wood, except the prongs, which ought to be of wrought iron, and firmly fixed into the axle with screw-nuts. The handle, or lever, has two iron braces to fix it the more firmly to the axle; and at the extreme end it has an iron loop, to which to attach a cord for pulling it down, when the prongs are under the ball of the tree to be lifted up.]

I have tried the power of this machine in the lifting of large

Portugal and common laurels, and have found that, by its assistance, the same number of hands can with ease perform twice as much work as they could possibly accomplish in the ordinary way. You may form some conception of its powers from the fact, that by its means four men can lift the plants as fast as three can make pits and plant them again. Another advantage attending the use of this machine is, that it does not in the slightest degree injure the roots; an advantage that cannot fail to be appreciated by every practical man, who has been accustomed to the old system of pulling the plant from side to side, in order to loosen it sufficiently in the hole, thereby unavoidably breaking and cracking the roots. By means of this machine, also, the ball of earth is in most instances preserved entire, as by its strong lever power the whole mass can be raised at once. In using it, the plant is prepared for lifting in the ordinary way, by tying up the branches, and digging round the ball at a distance sufficient for the preservation of the roots; the chief difficulty I at first experienced in the use of it was in getting it introduced below the ball. The first method I tried for the accomplishment of this object was, to drive it in with two wooden mallets, two men standing one on each side for the purpose of using them; but I afterwards found that I could more easily insert it by means of two levers held in a sloping direction, close to the axle, and which were pushed forward as the pole was wrought gently up and down. Before proceeding to work, however, the wheels must be taken off, in order that the machine may be placed in as horizontal a position as possible, and by doing so a twofold advantage will be gained; the prongs can be inserted deep into the earth, and greater additional lever power will be obtained. After the machine is properly placed under the ball, the pole must be lifted up high enough to admit a square piece of wood or other hard substance to be placed immediately below the junction of the pole and the axle, to act as a fulcrum or heel for the pressure of the lever; and, when the pole is pressed down, the plant is immediately raised and the axle elevated to a sufficient height to allow the wheels to be again put on. It is almost unnecessary to mention that the sides of the hole should be sloped down, in order that the plant may the more easily be drawn out. A mat or piece of canvass tied round the ball below the prongs will be useful in keeping the ball together; and after the plant has been fairly placed upon the machine, no difficulty will be found in conveying it to any distance.

This machine, although I have as yet only used it for the purposes above specified, I have no doubt will be found equally applicable to other horticultural purposes; for example, fruit trees, whose sickly appearance and deficiency of crops indicate that they have been by mistake too deeply planted, may

by its means be raised nearer to the surface, thus at once with ease and safety bringing their roots into a region more conducive to the health and fruitfulness of the trees. It may likewise be found useful in removing large plants from green-houses or conservatories, such as orange trees, aloes, &c. It should be made of the best malleable iron, with the exception of the wheels and the pole; the former may be made of cast iron or wood, and the latter of any material that may be found convenient, only, if made of wood, it will require to be of the cleanest-grown ash or elm. The whole expense does not exceed 4*l*.

Rossie Priory, Inchtute, Perthshire, Jan. 14. 1840.

ART. VII. *Notice of an Espalier Rail put up in Cossey Hall Gardens.* By J. WIGHTON, Gardener there.

AN espalier railing in Cossey Hall Gardens was put up there in the year 1830. It differs from any that I have seen. It is made of iron, except the posts at the ends, which are of oak. It cost less than some I have seen of wood, which in a few years would go to decay. The chief feature in which it differs from all others which I have met with, is in the horizontal direction of the iron rods. All other espaliers which I have observed, whether of iron or wood, have been on the old plan of perpendicular stakes or poles. The best I have seen, except the one in Cossey Gardens, was planned by the late Mr. Hay of Edinburgh, but it was still on the upright plan, giving the gardens a disagreeable caged appearance. This is not the effect of the espalier which I am describing. For the rods running horizontally, as the branches grow along them, the rods are concealed. The upright iron divisions which support the rods are seen, it is true; but they are very thin, and placed 12 ft. asunder.

A rail of this construction is very simple, and will last very long, if kept well painted. In Cossey Gardens there are 230 yards of this espalier. I have tried it with some of the best varieties of French pears, and found them ripen well. I have frequently seen good espalier rails with common apples and pears, that would have done well on standards.

The only objection I have heard made against the horizontal rail of which I am speaking is, that there would be some trouble in making the trees shoot out their branches at the exact distances required. But to this I should answer, that I have never found it more troublesome than to train horizontal branches along the courses of a brick wall. And it is one great advantage of this espalier, that the branches can be so easily trained along its horizontal iron rods.

Cossey Hall Gardens, April 10. 1839.

ART. VIII. *On certain prevailing Errors in laying out and managing Flower-Gardens.* By ALEXANDER FORSYTH.

It has often struck me with astonishment, to see, in some of our first-rate gardens, the meagre stock of what may be called midsummer flowers. Now, there are in many families great sums expended on gardens for the sole purpose of having one grand display of conspicuous flowers during the fine weather from midsummer till the middle of October; and as this class of families happily comprehends many of our best friends and patrons of gardening, viz. the wealthier merchants, and the members of parliament, who, tired with the dust and din of London, leave the court and the counting-house to inhale the uncontaminated air of heaven in the quiet loveliness of their flower-gardens; and as many of their gardens are really not worth while going out of one's way to see, for reasons for which gardeners are not altogether and at all times culpable; and as I hope that I have traced the evil (at least in many cases, and in some measure) to its origin, my humble efforts shall not be wanting to eradicate this fruitful cause of endless discontent and disappointment between the employed and their employers.

Leaving out one insurmountable difficulty over which the practical man has often no control, I mean where the employer grasps at more gardening than he is willing to allow the means to manage properly, I come to another which I am persuaded, if it were placed in proper light, the majority of employers would admit and allow to be removed, I mean the incongruous mixtures and unmeaning medleys that are every where to be seen in gardens, and to which even Loudon himself hath, in some instances, lent his aid; for I have somewhere seen in works bearing the well known J. C. L., something like the following, "We would admit of no herbaceous plant under deciduous and evergreen shrubs except spring bulbs." Now, with all due deference, I beg leave to remind you that you have laboured, and that successfully, to show the world that the day is gone by when a good deep raw-edged gulf should mark the boundary between the clean-swept lawn and the clump of rhododendrons, and instead of allowing their graceful forms to kiss the sombre clod, you have spread as it were a carpet around them. Now, would you have snowdrop and narcissus springing up in your grass? Adjoining the moss-clad walk in the wood you may plant them, where their foliage may remain unshorn till the bulbs are ripe and the herbage yellowed in the summer sun; there without labour they will remain comely and in character, like a brightly tinted halo thrown around the sphere of flowers; and, as their "heyday of blossoming" is frequently inhospitable, we look upon them as martyrs, mild amid their misery,

whose loveliness is enhanced by the ills they have borne, and have thus given them shelter where they had no business to be seen. But perhaps you will think that I am for discarding them from the flower-garden altogether, as vulgar and unsightly. No such thing: for the lilies are said to have surpassed King Solomon in splendour, and even the coarsest weeds have handsome flowers, only they are, I am sorry to say, too plentiful and misplaced for me to admire their presence here at this time. I should place your pretty spring flowers either in clumps devoted to them alone, or grow them in shallow tubs 3 ft. in diameter, in the reserve garden; and, letting them into the turf or soil up to the brims, I should stud the lawn or flower-garden with these hardy natives during the foul weather, whilst their foreign and more delicate brethren are stationed under shelter awaiting milder skies.

By this, you will see that I should like to give every thing a place to itself, suited to its nature and value. Now, suppose the proprietor of a garden to be a lover of birds (and who is not a lover of them?), and to request that in some waste corner shepherd's purse, groundsel, and chickweed be allowed to luxuriate, that he may with his own hand cull some every day for his canaries and goldfinches. The order is obeyed, and the mingled mass looks sluggish and detestable. But let them only be placed apart, allowing every one a separate bed (or two for a succession); and let every bed be divided by an alley edged with pebbles, and kept clean by sprinkling a little salt on it; and we have the appearance of system and design, showing that they are useful: and, in this character, weeds though they were, nevertheless, they now become highly satisfactory, though some sage gardeners may smile at the simplicity of this example of a systematic bird's-meat garden. I will turn their attention to another instance of more serious consequence, I mean the introducing of flowering plants into vineries and pineries, which have brought the red spider on the vine leaves, and the white scale on the pine plants, of whose ravages the gardener who is ignorant may be truly thankful.

But, to return to our arrangement of a first-rate garden, and assign to every class of flowers a compartment suited to their natures, so as they may attain the greatest perfection, and display that perfection to the greatest advantage; and I am only desirous of going with the stream, or rather torrent, of public opinion, that has already uprooted many venerable medleys; I propose, in a series of sketches, at some future period, to show how this may be done, consistently with all the doctrines which I have advanced. But these sketches, and the directions for carrying them into execution, I must defer for the present: besides, I am quite aware that engraving them might put you to a greater

expense than you might be willing to incur, liberal as you are in your graphic illustrations.

Cheshire, January, 1838.

ART. IX. *On the Treatment of Cape Iridææ.* By W.

THE plants belonging to the natural order Iridææ, from the Cape, have for many years possessed great attractions for me; from a period when they were scarcely to be procured, except through some accidental circumstances, and before they engaged as much general attention as they have now obtained. The mode I pursued in cultivating them was, accordingly, the result of my own experience; for though in the West of England I have seen beds of *Sparaxis grandiflora* and *S. tricolor* in great perfection in the open ground, still I always found the best success attend the following system; and I am inclined to think the delicate beauty of the flowers of this order is shown to greater advantage, when, from being grown in pots, these plants can be removed to the green-house.

In the month of October the bulbs were examined, and the larger ones, separated from the offsets, were potted in a compost of fresh light turfy loam and sand, with good drainage; and I have found, with regard to the stronger-growing *Gladioli*, a layer of rotten cow manure over the drainage conduce much to the vigour of their growth. At the same time I had a good bed prepared of dry old tan mixed with some fresh hot litter from the stable, at least 2 ft. in thickness above the level of the garden, and on the top a large frame placed. Within this the pots were plunged in old tan; the stronger-growing *Gladioli* at the back; *ixias*, *sparaxis*, *babianas*, *tritonias*, &c., arranged in gradation to the low-growing species of *Oxalis* and *Lachenalia* in front. The lights were put on at night, giving abundance of air in fine weather, and withholding water until the bulbs had made roots and the leaves appeared, at which time it was carefully given, to avoid exhausting the bulbs by drought, when there was no danger of frost. On the occurrence of severe weather, I had the frame well banked round with old tan, assisted by hot dung, and the lights well protected by external coverings.

Under this management the sorts of *Sparaxis* began to show bloom about the end of April, and, being removed to the green-house, opened their flowers to the sun with great brilliancy. The *ixias* and *babianas* succeeded them, and were also removed to the front of the house. The *Gladioli* usually outgrew the height of the frame, and threw up their flower stalks vigorously on the stage of the green-house. Lastly, the varieties of *Tritonia*

formed a blaze, in shades of orange, copper colour, and pink. After the blooms were past, I continued watering the pots, to perfect the foliage, and form the bulbs for the ensuing season; and by replacing them in the frame, and giving them full exposure to the sun until the leaves gradually died away, the bulbs became thoroughly ripened. After a period of drought and rest, they were ready for repotting the following October.

For the last two years I have not had opportunity to continue my accustomed method of culture, and last autumn my *Cape Iridææ* were placed in a cold-frame, from which the frost was just excluded during the winter, and the pots plunged in sand: they look badly, and will not flower, which I attribute partly to the bulbs not being well matured, owing to the cold wet summer of last year, and more especially to their not receiving a requisite degree of bottom heat to induce them to form roots freely during the winter, which insures a vigorous growth of the leaves, and the production of flowers. To attain this end, the temperature of the soil in the pots must be some degrees higher than that of the atmosphere which surrounds them.

Gloucestershire, April, 1840.

ART. X. *On raising Seeds received from the Swan River Colony.*
By J. BREWSTER, Gardener to Mrs. Wray, Oakfield Lodge, Cheltenham.

THE publication by Dr. Lindley of his learned and valuable *Sketch of the Vegetation of the Swan River Colony* (see p. 94.), has imparted a zest to the efforts now making by many of the lovers of horticulture, to be possessed of seeds from that interesting part of the world. A few remarks on a successful method of sowing and raising these seeds might, perhaps, be of service to some of your readers, especially to amateurs, many of whom receive large and valuable collections, without the requisite knowledge to raise and bring them to perfection.

On the 1st of February I prepared the pots destined to receive the seeds, by draining them to fully one third of their whole depth. I then filled them with a compost of equal parts of maiden loam and sandy peat, pressing the mould slightly with a piece of flat wood. I then sowed the seeds, covering them with a little of the same mould, again pressing it as before; the depth of covering must be regulated according to the size of the seed. I then placed them in a stove, sprinkling them with water two or three times a day, taking care never to allow the surface of the mould to dry. In ten days after sowing, many of the seeds appeared above ground; and, by the twentieth day, two thirds of the whole were growing fine plants, including several species of *Stylidium*.

I am fully convinced that Swan River seeds will germinate better under the above treatment than by the common practice of placing them in a cold-frame, and that even the young plants will not only stand but grow better in a high temperature. As a proof of which, my esteemed employer, Mrs. Wray, raised (last year) a number of very interesting plants from Swan River seeds, some of which were placed in the stove, and others in the green-house: those in the stove are now three times the size of those in the green-house, and appear much more healthy. A few of these are now showing flower, which I believe to be new to this country; but, as they will soon prove themselves, I shall refrain from making any premature remarks. There are also several species of a genus the appearance of which is quite a novelty to our gardeners, being more like a common rush (*Juncus conglomeratus*) than any thing I know.

Oakfield, Cheltenham, April 10. 1840.

ART. XI. *On the Jerusalem Artichoke.* By ALEXANDER FORSYTH.

IN March or April plant the tubers, cut into sets like potatoes, with a bud in each, in rows alternately 1 ft. and 3 ft. apart, dropping the sets about 9 in. apart in the row. As the plants advance they must be topped (say when 18 in. high), and earthed up; in autumn they may be used, as soon as tubers can be got as large as a pigeon's egg. When frost approaches, they may be carefully forked out and collected, when the best may be stored in cold dry earth for use and sets, and the inferior ones boiled for pigs or poultry, but by no means wheeled with other waste vegetable substances, lest they should afterwards prove troublesome as a weed.

Isleworth, October, 1836.

ART. XII. *On the Wild Potato (Solànum tuberòsum).*

(Translated from Pöppig's *Reise in Chile und Peru*, for the *Gardener's Magazine*, by J. L.)

AMONG the cultivated vegetables in the Andes of Peru, none is more remarkable for its abundance and goodness than the potato. The question has often been asked in modern times, whether this plant is met with in a wild state in Peru and Chile; and, besides what has been said by the meritorious Lambert, Alexander Cruickshanks, whom I accompanied in 1827, made the strictest enquiry respecting it in Chile, and has written on the subject. I fully agree with him that the potato is a native of, and still grows wild in, Chile; and I am the more convinced

of it, from my further search respecting the plant in the southern provinces, where Mr. Cruickshanks did not accompany me, as I found it quite as abundant there as in the northern parts. Humboldt is of opinion that the potato grows wild in Peru, from which opinion I am obliged to differ, at least so far as to state that, during my journey in the Andes, I found no tuber-bearing solanums on their declivities between 5° and 12° of south latitude. The potato in its wild state, however, is not an inhabitant of the mountains: but, in the northern part of Chile, where both Mr. Cruickshanks and myself made a journey along the coast, and carefully examined it, and also in the southern part, where I travelled alone, we found an immense quantity of wild potatoes at a height never exceeding that of 400 ft. above the level of the sea; more generally, however, in the immediate neighbourhood of the sea, and in the greatest luxuriance in rich loamy declivities, or in the chinks of the rocks exposed to the sea breezes, and only elevated a few fathoms above the level of the ocean. We never saw the wild potato farther from the sea than one or two leagues. It is easily distinguished from the cultivated potato, when it is once known that its blossoms are always white.

The potato, by right, ought to bear the name of a sea-shore plant, and its native country is undoubtedly Chile. It has been said that this plant is found cultivated on the hills that border the coast, and on the steep rocky declivities at Punta de Quintero, &c., but the soil there is either incapable of cultivation, or the land so steep that nobody could make any use of it. The wild potato is often known in Chile by the name of *Papa cimarono*, because in its natural state its very small tubers are found to be bitter. They are often found growing in a wild state on steep places; and in 1827, when the fort at Valparaiso was pulled down, and part of a steep rock gave way, and also in 1828 at the Cerro alegre, such an extraordinary quantity of those uneatable tubers rolled down into the streets, that many strangers who had never seen the wild potato could hardly believe the assertion. It cannot be affirmed that the wild potato is found in good soil, or in the drift hills of sand at Quintero; it, on the contrary, prefers the steep declivities and the small step-kind of formation on high projecting rocks. That the wild potato is very sensitive of a change of atmosphere, is evident from the circumstance, that it is found in abundance at the foot of Monte Manco, not far from Cocon in Chile; but not at all on its summit, a height of 500 ft., where, on the contrary, fields of the cultivated potato flourish well. The potato is not used to the same extent in Chile as it is in Peru, where the inhabitants of the Andes, without the least exaggeration, derive more than the half of their nourishment from its tubers. The Indians

and Mestizos there make what they call *Chupe*, that is, small pieces of potato boiled in water, with the addition of pepper, and generally seasoned with bullock's fat; this dish they partake of two or three times a day, and it forms their chief food. Its great cheapness and satisfying quality reconcile the natives to its tastelessness and less nourishing property; and the Mestizos of the mild valleys would rather live on *Chupe* six days in the week, than be obliged to work hard two days together. The inhabitants of Punas are well skilled in preserving potatoes to keep to any length of time, which methods are not generally known in Europe. They give the name of *Chúnu Chúno* to the best-tasted preparation, which consists of potatoes left spread out in the open air for several nights, and exposed to the frost; during the day, however, they are put in a cold place, and protected from light and heat, so that they neither rot nor have a bad smell. They are then laid between layers of straw, and the small degree of moisture they contain pressed from them by treading and pressure, so that they at last form a mass of a whitish, wrinkled, light substance, and which, when boiled, forms a gelatinous liquid of a light grey colour and a not unpleasant taste. This preparation is brought from Sierra to the coast, and also to the warm forests towards the east, where it is in great repute. It keeps good for several years together in the climate of the Andes, and it even suits better the moist heat of the ancient forests than any other vegetable preparation. I found this provision very useful to me during my journey to Huallaga; and it did not a little excite the astonishment of the inhabitants of Brazil, as on the banks of the Marañon no kind of dried provision will keep one year.

The second preparation is called *Morai*, and only differs from the preceding in the potatoes being pared, and otherwise managed with greater nicety.

A third way of preserving the potato consists in cutting them in thin slices, and fastening them on a string. They dry well and very quickly in this manner in the atmosphere of the Andes. The potatoes of the Sierra are not much larger than a large kind of walnut, which we in Germany call *Wälsche Nüsse*, but they have a particularly good flavour, and, like those in Europe, consist of a great many varieties. In the forests of the warm regions of the valleys, which reach as far as Huanuco, the inhabitants cultivate a very excellent variety, probably a peculiar species, as it is very sensitive of cold, and produces tubers every three months. When it is once planted, it requires no more care, but continues to flourish. I found it common also in Cuchuro and Cassapi, and the flavour was very good. (*Pöppig's Reise*, vol. ii. p. 81.)

REVIEWS.

ART. I. *Catalogue of Works on Gardening, Agriculture, Botany, Rural Architecture, &c., lately published, with some Account of those considered the more interesting.*

THE Landscape-Gardening and Landscape-Architecture of the late Humphry Repton, Esq.; being his entire Works on these Subjects. A new Edition, with a Historical and Scientific Introduction, a Systematic Analysis, a Biographical Notice, Notes, and a copious Alphabetical Index. By J. C. Loudon, F.L.S., &c. Originally published in one folio and three quarto volumes, and now comprised in one volume, 8vo, illustrated by upwards of 250 engravings. 8vo, pp. 619. London, 1840. 30s. plain; 3*l.* 6s. coloured.

We announced the appearance of the first number of this work in our preceding volume (p. 466.). It is now completed, and forms one of the best practical guides for the young or amateur landscape-gardener extant. There are, doubtless, a number of our readers who have perused the works of Whately, the two Masons, Gerardin, and Uvedale Price, and to these we may appeal for the truth of what we assert as to the practical nature of Mr. Repton's writings. The truth is, that, by the number of engravings which they contain, they address themselves to the eye at once; and a general idea may be formed of the nature of landscape improvement by merely turning over the pages, and looking at the engravings. We do not know a book better adapted for a drawingroom than a coloured copy of this work; not only from the beauty of the pages, but from the interest excited by the views or vignettes, which exhibit portraits, before and after improvement, of upwards of two hundred of the most remarkable country residences in England. The coloured copies we consider as exquisitely beautiful, and particularly those which have been done at Bayswater, under our own inspection.

A portrait of the late Mr. Repton, by Hall, from an original drawing by Shelley, is prefixed to the work; which Mr. Repton's family, we are happy to say, consider a better likeness of their father than that published in his lifetime as a frontispiece to his quarto volume, entitled *Observations on the Theory and Practice of Landscape-Gardening*. The biographical notice, which occupies twenty-two pages, will be read with intense interest, as showing Mr. Repton to have been a highly enlightened and most benevolent man.

The Ladies' Flower-Garden of Ornamental Annuals. By Mrs. Loudon. Illustrated by forty-eight carefully coloured plates, containing upwards of 300 figures of the most showy and interesting annual flowers. 4to, pp. 272. London, 1840. 2*l.* 2s. cloth; 2*l.* 10s. half-bound in morocco, gilt tops.

This elegant volume being now completed, we have only to repeat the expression of our warmest approbation of the plan and of the manner in which it has been executed. The tasteful grouping, the truth of imitation, both in forms and colours, of the plants figured, have been maintained throughout; and the letterpress is every way worthy of the plates. With the last number is given an index of English and scientific names, the latter being accented; a glossary of terms, including all such as are in general use, though not clearly understood; for example, awned, disk, embryo, fibrils, floral leaves, &c.; a list of authorities and books referred to; the contents, arranged systematically, each order forming a chapter; and, lastly, a list of plates, with the English and scientific names of the plants figured in each. The total number of plants figured is 310, which, being purchasable for 2*l.* 2s., is only a fraction more than three halfpence for each figure. We feel confident that there is not extant another work relative to botany or gardening, in which elegance, economy, and utility are combined in such an eminent degree; and, happily, the success of the work has been proportionate to its merits.

The Ladies' Flower-Garden of Ornamental Bulbous Plants. By Mrs. Loudon. No. I. 4to, pp. 16.; 3 coloured plates, containing 20 figures of bulbous-rooted plants. London, 1840. Price 2s. 6d.

In pursuance of the plan which we announced in our preceding volume (p. 729.) when speaking of the *Ladies' Flower-Garden*, the *Ornamental Annuals* are no sooner finished than the *Ornamental Bulbous Plants* are commenced. The number before us is an admirable specimen, both in regard to its letter-press and its plates. The first plate is entirely devoted to the genus *Iris*; the second to the genus *Moræa*; and the third to *Herbétia*, *Cypélla*, *Phalocállis*, and *Vieusseuxia*. Bulbous plants, taken individually, are generally stiff erect objects, which one would suppose could not be very readily brought together so as to form elegant groups; but the fallaciousness of this opinion is demonstrated by these plates, in which, while every individual species is true to nature, we have each group equally true to the principles of pictorial combination. The bulbous department, therefore, of the *Ladies' Flower-Garden* promises to equal, if not to surpass, that devoted to annuals.

It is calculated that this volume will be completed in about the same number of parts as the *Annuals*, after which the *Ornamental Perennials* will be commenced.

Fruit Trees; a Handbook for Cultivators. Being a practical Exposition of the Art of pruning Fruit Trees; showing the Defects and Difficulties of modern Practice, with proposed Remedies; including Advice and Information, founded on long Experience and extensive Observation. By a practical Observer. 12mo, pp. 119. London, 1840.

An excellent little work, by a well-known author; alike admired for his scientific knowledge, and his extensive experience in the practice of what he teaches. Why he has not given his name we are at a loss to conceive; since it would have prevented his book from being confounded with other anonymous productions equally cheap, but so far inferior in point of merit, that, were it not for the harshness of the term, we should call them worthless. Generally speaking, we recommend our readers to purchase no practical work of any kind which has not the author's name attached. With works purely argumentative this is of no consequence; and, indeed, the name may often tend to obstruct the free exercise of thought: but, with those giving directions for managing a garden or a farm, or for treating cattle or live stock, the first step, in our opinion, is to know what degree of confidence is to be placed in the author. The key to this degree of confidence is the author's real name.

A Method of pruning and training Standard Apple Trees. By James Clark, Gardener to the Earl of Lonsdale, Castle Gardens, Whitehaven. Pamph. 12mo, pp. 8, with a plate. Whitehaven, 1839.

The great object in the "windy part of the kingdom," where the author is situated, is to keep the trees as low as possible, and the wood not crowded, but in straight and stiff ascending and spreading shoots. These objects he attains by thinning and shortening in the manner performed in the London Horticultural Society's Gardens, with the apple trees in the borders of the orchard; and also, as Mr. Clark informs us, as performed in the Experimental Garden, Edinburgh, when under the direction of Mr. Barnett.

A descriptive Catalogue of Fruits cultivated by T. Rivers, Jun., at his Nurseries, Sawbridgeworth, Herts, with the Prices of Fruit Trees. Pamph. imp. 8vo, pp. 16. London, 1840.

A descriptive Catalogue of Pears cultivated by T. Rivers, Jun., &c. pp. 4.

[The following is from a correspondent who has paid great attention to the subject of fruits.]

The descriptive fruit catalogue of Mr. Rivers is a commendable innovation upon the usual form of nurserymen's lists, which have hitherto been little or

nothing more than long rolls of bare names, without any particulars by which purchasers might be guided in their selection of sorts. Its general correctness is creditable to Mr. Rivers; there are, however, some inaccuracies, of which the following have occurred to me in a hasty perusal.

Among the Apples there are very few sorts that are not worthy of cultivation; but a few of those of which the names are printed in italics scarcely deserve that distinguishing mark of excellence, while others not thus distinguished, are of the highest merit. For example, the Dutch Mignonne and Forman's Crew are much inferior to the Herefordshire and Adams's Pearmain, two of the very best apples in cultivation; Braddick's Nonpareil and the Old Nonpareil are also quite equal, if not superior, to the Sweeney Nonpareil. No collection, however select, should be without the Old Golden Pippin; Hughes's Golden Pippin, and the Summer Golden Pippin, are also of first-rate quality. Besides these, the King Pippin, Margil, Oslin, Golden Reinette, and Boston Russet are excellent sorts, equal in merit to most or all of those selected by Mr. Rivers. He makes *two* Ribston Pippins, which is evidently incorrect. That apple was named after a place in Yorkshire (Ribston Hall) where it originated; consequently its name, although it is slightly modified, cannot justly be given to a different apple: the Winter Ribston Pippin is therefore either some other sort, or merely a nurseryman's name, probably the latter, for the true Ribston Pippin will keep till spring.

Of Apricots, Mr. Rivers gives three new names:—the Early Red, Large Red, and Large Peach, which he tells us in a note are "French varieties of the Moorpark," a piece of information not very easily understood. If these apricots do really differ from the Moorpark, they are not varieties of it any more than of the Turkey or Breda, but *bonâ fide* sorts; I suspect, however, that these three, and also the Hemskirke, are nothing more than the Moorpark. Let Mr. Rivers bud them all upon a fruiting tree of the Moorpark, and, if there is any real difference, it will then be clearly perceptible.

His list of Cherries contains most of the best sorts:—the Belle de Choisy is a very good tender-fleshed cherry, quite distinct in character from all others that I am acquainted with. The Black Eagle is not "rather small," but a good-sized cherry, and, with the rest of Mr. Knight's seedlings, well deserving of extensive cultivation. The Downton and the Elton are, however, the best of those raised by that distinguished horticulturist, and are not surpassed in goodness by any known kinds. That called Knight's Early Black is thought to be synonymous with the Black Tartarian, a large and excellent cherry. The Early Purple Griotte is now called Early Purple Guigne.

About Figs very little is known by any writer on fruits. Mr. Rivers has judiciously reduced his list to nine names, which, with the Nerii of Mr. Knight, and some two or three others, probably comprise all the sorts cultivated in this country. It is much to be regretted that so little attention is paid to this delicious fruit.

The collection of Gooseberries is small, many of the best kinds being omitted. Crompton's Sheba Queen, not "Sheba's Queen," is of the highest excellence. Taylor's Bright Venus is not a "Lancashire prize sort," with which it is classed, but a middle-sized berry, in the way of the Pitnaston Green Gage, and, like it, delicious in flavour, and possessing the valuable property of hanging a long time upon the tree. The list given in the *Penny Cyclopædia* (article Gooseberry) is, perhaps, the best that could be made, and those who desire a first-rate collection should take it for a guide.

It is in Grapes that Mr. Rivers is most at fault; that, however, will not surprise any one conversant with fruits, for, with the exception of figs, there is no class in which so much confusion exists. Most writers upon grapes are mere copyists, each rigidly adhering even to the errors of his predecessors. Prince's *Treatise on the Vine*, published at New York in 1830, contains more original matter than any British work that I have seen, many of his descriptions having evidently been drawn from nature; and, although by no means free from errors, it is a very useful and instructive book. Many of Mr. Rivers's

sorts I have never seen ; amongst those I am acquainted with, the following errors occur. The berries of the Black Prince are not "roundish," but conspicuously oval, and between it and the Cambridge Botanic Garden grape there is not the slightest difference. The figure of the latter in the *Pomological Magazine* is a correct representation of the Black Prince, with which variety also the description exactly agrees. In the North of England, this grape is frequently called the Black Spanish, and in some places the Black Alicant.

The Black Constantia, although perfectly distinct, is usually confounded with the Frontignans : it is commonly called in gardens the Black Frontignac, and is described in books under the name of Blue or Violet Frontignan. The habit of the plant, and the appearance of the fruit when in a young state, resemble in some degree the Frontignan tribe ; but the fruit when ripe, although sweet and very agreeable, is totally devoid of that exquisite muscat flavour for which all the Frontignans are so deservedly esteemed. The berries are likewise smaller, less round, and of a more intense black than those of the Black Frontignan.

Pomological writers make five varieties of Frontignan ; but from a careful comparison of their descriptions, and from my own observations made on growing plants, I am decidedly of opinion that there are not more than *three* distinct sorts cultivated in this country ; which are, 1. The Black (Muscat noir of the French ; Purple Frontignac, Purple Constantia, of some) ; 2. The White (Muscat blanc of the French, White Constantia of some) ; 3. The Grizzly (Muscat rouge of the French) ; the Red Frontignan of English authors is nothing more than the Grizzly ; and the Black Constantia makes the fifth. The Chasselas précoce is very similar to, if not identical with, the White Sweetwater, sometimes called Stillward's Sweetwater, and New Sweetwater. The White Muscadine is by some called the Sweetwater. The Eshcollàta supérba is probably an old sort with a new name (see p. 107.). Frankenthal will, I suspect, eventually prove to be the proper name of our Black Hamburg, the latter appellation being merely the name of the place from which it was introduced into this country. A German gardener high in his profession, who has seen the Frankenthal on the Continent, is of opinion that it is the same grape as the Black Hamburg. Brown, red, and purple Hamburgs only exist in imagination, or in books. The late Mr. Money affirmed that the Lombardy and Flame-coloured Tokay are different grapes, and that the Wantage is synonymous with the latter. The Horsforth Seedling is said to have been raised from seed in the garden of the Rev. W. Rhodes, at Horsforth Hall, near Leeds. I have seen it growing in the same house with the Black Morocco, and could not perceive the slightest difference between them. The Cannon Hall Muscat is said to differ from the White Muscat of Alexandria, "at least in some situations:" it differs in all situations, being a totally distinct sort. The berries of the Cannon Hall are considerably larger than those of the White Muscat, less pointed, thicker skinned, and certainly inferior in flavour ; it also ripens ten days or a fortnight earlier in the same temperature. Besides these differences in the fruit, there is some dissimilarity of habit, the Cannon Hall being grosser in all its parts and constitutionally more tender. Some doubts are said to exist as to the fact of its English origin. The White Tokay is the White Muscat of Alexandria. In the North of England it is generally known by the first name.

The berries of West's St. Peter's are not round, but rather oval. In Lindley's *Guide to the Orchard and Kitchen-Garden*, it is called Black Lombardy, a name which, if not preoccupied by another sort, would be infinitely preferable to its present absurd appellation, Oldaker's West's St. Peter's, especially as there is another grape called Money's West's St. Peter's (properly, Raisin des Carmes), and a St. Peter's besides. I have heard the Black Prince called Black Lombardy. The Grove End Sweetwater is a foreign variety, called on the Continent "Früher Leipsicker," or Early Leipsic. The

White Raisin has oval berries: its flesh is exceedingly firm, and has very little flavour.

Of Nectarines, Mr. Rivers has several new names, but it is questionable whether they are all new sorts. Du Telliers, or Duc de Tello of the nurseries, is the *Violette hâtive*, one of the best of nectarines.

The claim of the hardy Gallande peach to be considered distinct from the Bellegarde is apparently founded upon its property of taking "readily if budded upon the mussel plum." I greatly doubt, however, whether that seeming peculiarity of constitution ought to be considered a legitimate ground of distinction between individuals agreeing in all other respects, because the failure of the Bellegarde buds on the mussel stock might, even on repeated trials, have been caused by accidental circumstances altogether unconnected with constitutional difference. We ought to be extremely scrupulous in adding new names to our already too lengthened lists.

The list of Pears contains nearly all the best varieties; several new names are also given, such as *Beurré de Noïrchain*, *Beurré de Flandres*, *Incomparable Beurré*, &c., &c., of which the merits in this country can scarcely yet be sufficiently ascertained to justify their recommendation. We have now so many pears known to be good, that the utmost caution is necessary in recommending novelties. The new pear, absurdly named *Van Mons Leon le Clerc*, about which so much has been said, has not yet been fairly tested.

It would be very desirable to ascertain whether that best of plums, the *Green Gage*, is in reality different from the *Reine Claude*; and Mr. Rivers will probably soon be able to clear up this disputed point. *Denyer's Victoria* is thought by some to be the same as *Sharp's Emperor*.

The selection of strawberries would be improved by the addition of the *Garnstone Scarlet*, *Grove End Scarlet*, *Coul Late Scarlet*, *American Scarlet*, and *Black Roseberry*. — *J. B. W. London, April 14. 1840.*

Perkins's improved Patent Apparatus for warming and ventilating Buildings. Pamphlet 8vo, pp. 43, 8 lithographs. London, 1840.

In this little tract Mr. Perkins has described his recently invented governor, or heat regulator; by which no excess of temperature can ever take place in plant houses or other buildings heated by his apparatus. The governor acts by the expansion of metal pressing on a series of compound levers, so that the slightest change is powerfully effective. We are informed by W. Groom, Esq., of Bury St. Edmunds, that, by means of the governor, and with the use of anthracite coal, the fire need not be attended to more than once in twenty-four hours. The fire is made up at 8 o'clock every evening, and never looked at in the course of the day; and, whether the weather is warm or cold, the temperature never varies more than 3° or 4°, and this variation is chiefly occasioned by bright sunshine. Mr. Groom has had one of Mr. Perkins's heating apparatus eight years, and a governor affixed to it for about half that period.

The Literary World; a Journal of Popular Information and Entertainment. Conducted by John Tims. Vol. II. 8vo, pp. 412. with 84 wood-engravings. London, 1840. Price 5s. the volume, or 2d. a number.

We have noticed the preceding volume of this very elegant work in our Magazine for the last year (p. 763.), and have only to say that we cannot sufficiently admire the care and the taste with which it continues to be got up. The literary matter is select, and in many cases original; and the engravings are admirably executed and beautifully printed. We admire in particular the specimens of London street architecture, which, as the book is so exceedingly cheap, will, we trust, tend to diffuse a taste for architectural improvement in country towns and villages. We wish every young gardener could afford to take in the work weekly, as a means of elevating his taste, as well as supplying him with abundance of rational amusement.

The Year-Book of Facts in Science and Art; exhibiting the most important Discoveries and Improvements of the past Year, in Mechanics, Natural Philosophy, Electricity, Chemistry, Zoology and Botany, Geology and Geography, Meteorology and Astronomy. Illustrated with engravings. By the Editor of the "Arcana of Science." Small 8vo, pp. 286. London, 1840.

In our preceding volume (p. 179.) we have strongly recommended this work to such of our readers as desire, at an easy rate, to attain a knowledge of the inventions, discoveries, and improvements which have taken place during the last year. In the compilation for the year 1840 the editor has not spared labour, taste, or judgment to secure an extension of public favour; and this we have no doubt he will obtain. To those who have not an opportunity of perusing the scientific periodicals as they appear, monthly or quarterly, this annual summary must be invaluable.

The Principles and Practice of Levelling. By Edward Jones, Architect and Civil Engineer. Second edition, revised and corrected. Post 8vo, pp. 70, various woodcuts. London, 1840. 4s.

A useful little work for the young gardener; because, without a knowledge of the art of taking levels, he cannot possibly understand how to carry ground plans into execution. In the work before us, not only the art of levelling is explained, but the principles on which it is founded; and both in so clear a manner, as to be understood even by those who have no previous geometrical knowledge. "Regardless of a profit from the sale," says the author in his preface, "the present work is offered to the public, happy if it shall meet with their approbation."

London Architectural Precedents; with Notes and Observations. Edited by an Architect. Illustrated with working drawings. 8vo, pp. 48, four copper-plates. Part I. 1840.

This promises to be a useful work, more especially for young architects; and it will also be instructive to amateur builders. No. I. of the *Precedents*, contains, "Plans and Elevation, Sections and Specification, and a Bill of Quantities of second-rate Buildings." One thing is wanting to give this book its full weight with the public, and that is, the name of the editor, which by an advertisement appears to be, Alfred Bartholomew, Architect.

ART. II. *Literary Notices.*

GARDENING for Ladies, by Mrs. Loudon, Author of "The Ladies' Flower-Garden," in one volume post 8vo, illustrated with engravings, will appear on the 1st of May, or before.

This will be found the best book for teaching ladies how to garden with their own hands, that has hitherto been published.

The Companion to the Ladies' Flower-Garden, by Mrs. Loudon, is now printing, and will be published in May or June.

This work will contain a dictionary of all the plants, ligneous or herbaceous, hardy or tender, cultivated in British gardens, that are truly ornamental, and as such intended to be figured or otherwise noticed in the series of volumes by Mrs. Loudon, now publishing under the title of "The Ladies' Flower-Garden," and, as we have elsewhere mentioned, to include, before the whole work is finished, perennials, shrubs, trees, and green-house and hot-house plants.

The *Companion* will enable those who cannot wait for the completion of the several volumes, to go on selecting and cultivating in the meantime; and as it will contain not only a dictionary of plants, but of all the different operations of culture, including articles on Air Plants, Alpine Plants, Annual Plants, Aphis, Arboretum, Ashes, Bark, Bark-stove, Bast Mats, Beds,

Bell-glass, Bellows for Fumigation, Biennial Plants, Borders, &c., &c., including Cuttings, Layers, Grafting, Sowing, Hoeing, Digging, Potting, Pruning, Training, and a great many such terms, it may be considered as a general dictionary of ornamental gardening, adapted for the use of ladies. It is printed in double columns, in a very small type, and will form a volume of five or six hundred pages, illustrated by engravings.

MISCELLANEOUS INTELLIGENCE.

ART. I. General Notices.

BOTANICAL and Horticultural Works.—I deem it the duty of every gentleman to permit his gardener to have all reasonable access to even his most valuable books on botanical and horticultural science. This is only fair; for how can he expect perfection if he refuses the necessary means of information? He might as well lock his stable bin, and expect his stud to be fat and sleek.—*Amicus.* Feb. 6. 1840.

Seeds sent by Post.—We have lately received not only seeds, cuttings, and scions, but even entire plants, and yesterday a shrub, roots and branches (*Vaccinium humifusum*), in a penny letter. From Messrs. Sang of Kirkcaldy we received a prepaid packet very neatly done up, containing the seeds of 12 kinds of annuals, each with the name printed, and the price of the whole 12 only 1s. If this does not lead to the general distribution of every useful and ornamental plant of which seeds are procurable, the fault will be in the public, not in government. We only wish that the foreign postages could be lowered a little, that our ornamental annuals might be sent all over the Continent; for, it is a fact that will not be denied, that annual plants, even those of warm climates, make a far more splendid appearance in Norway, Sweden, Russia, and the North of Germany, than they do in England, owing to the brighter sun and longer days of these countries during the summer season. Great part of the Californian annuals might be naturalised in the woods of Norway and Sweden, and many superior varieties of bread corn, and of pasture grasses and herbage plants, might be introduced into these countries by post, if the postage abroad were only a little lower. An interchange of seeds amongst all the curators of botanic gardens in Europe and America is a result to be anxiously desired, not merely by the botanist, but by the horticulturist and the farmer. If ambassadors were what they ought to be, matters of this kind would have been attended to long ago.—*Cond.*

Clerodendron squamatum Vahl and Hort. Brit., speciosissimum *Part.*—I have had several applications lately, from amateurs in several parts of the country, to tell them where they could buy the *Clerodendron squamatum*, or if it could be had in any of the London nurseries; and this morning I had a note from a first-rate London nurseryman, asking me if I had this plant, while, to my own knowledge, he had half a dozen of it in his stores. I wish you to insert this paragraph for the use of others who may be looking out for *C. squamatum*. You can refer them to the *Gardener's Magazine*, vol. xiii. p. 39., and *Botanical Register*, t. 649.; it is the same as *Clerodendron speciosissimum*. Last autumn I saw a plant of *C. paniculatum* beautifully in flower, in Mr. Knight's Exotic Nursery, and in a short time afterwards I saw an account of this plant somewhere which I now forget, and I think *squamatum* was the name mentioned, at least I recollect some wrong name applied in the report I read.—*D. B.* London, March 27.

Imported Orange Trees.—I have frequently found a very simple hint of great service; I forward you the following, in hopes that some person may have a chance of being benefited by my experience. In 1838, we had six orange trees imported from Malta; they had been one year from the bud; the labels were fastened with iron wire to the young shoots, and had rubbed the bark of three of them near to the stock. I covered them all over with moss,

which I kept moist, and, after having soaked their roots for twenty-four hours in water, I potted them. Three of them began growing finely, but the other three not at all, partly from the injury done by the wire, and partly from the roots having been mutilated. It occurred to me, that, if by any means I could excite the top, the excitement at the root would follow of course, so I placed the thriving and the others side by side, and inarched them together; the result was, that the buds began to swell, and at last they began with vigour to push. I then cut back the shoots of the scion, and also all buds, leaving a few good leaves, and finally I cut the connexion altogether. All of them now get on charmingly. The part of the scion attached to each is a memorial whereby to distinguish them.—*G. M. Elliot. Ripley Castle Gardens, Feb. 29. 1840.*

Pocock's Patent Flexible Asphalte Roofing.—A novel manufacture is offered to the attention of the public, called Flexible Asphalte Roofing. It is intended to supersede the use of slates, tiles, zinc, thatch, &c., in the covering and lining of farm-buildings, sheds, cottages, and other erections; and, from its durability, lightness, and economy, it is expected to be brought into very general use. The weight of this manufacture being only 60 lb. to the square of 100 ft., the walls and timbers to support it are required to be but half the usual substance; it is also a non-conductor of heat, impervious to damp, and will bear a heat of 220° without injury. Several architects and railway engineers have, we understand, already adopted the asphalte roofing for sheds and other buildings; and we are informed that the roofs of the Slough Station, on the Great Western Railway, will be covered with this material. (*Mech. Mag.*, No. 865. March 7. 1840.) This roofing might, probably, answer for the flooring of borders for fruit trees to prevent the roots from penetrating to the subsoil. We should be glad to hear of its being tried; and, where this is done, we would suggest that a coating of gravel or brick rubbish, of 5 or 6 inches in thickness, should be laid immediately over the asphalte, to serve as drainage. Vertical plates of this material might be arranged as a conservative or fruit-tree wall, and it would form excellent linings to basins or ponds in flower-gardens.—*Cond.*

Ornamental Pottery for architectural gardens and terraces has lately been much improved, and among the recent candidates for public patronage are Singer and Co., of the Vauxhall Pottery, on whose premises may be seen a great variety of articles that will interest the landscape-gardener, and the garden architect.—*Cond.*

ART. II. Domestic Notices.

ENGLAND.

GARDENING in the Neighbourhood of Liverpool appears to be in a prosperous state; one nurseryman there being at present engaged in planting the grounds of no fewer than eight villas. In these the pineries are all heated by hot water, even the bottom heat being communicated by that medium. In some cases a flooring of boards is laid over the pipes, and covered with rotten tan, sand, or ashes, in which the pots are plunged; and in others a stage of boards closely joined together is formed, and circular openings cut in each shelf of the stage the exact size of the pots intended to be used; and these pots are suspended by their rims in the openings, so that the bottom and sides of the pots come in immediate contact with the hot air below. Both these modes, we are informed, answer admirably.—*W. H. Liverpool, March 23. 1840.*

Rhododéndron arbóreum híbridum, in the Albion Nursery, Stoke Newington, Mr. Milne's, is 10 ft. high, symmetrical and graceful in form, and covered with above a hundred heads of bright crimson flowers. I would go twenty miles, to see such a plant.—*B. B. Billington. Stoke Newington, April 13. 1840.*

Gardener's Benevolent Association.—We noticed the foundation of this institution in our previous volume (p. 196.), and we are glad to find that it is

going on steadily and prosperously. At a meeting of the Committee, April 14., the first two pensioners were named: they were, the widow of an aged gardener, and an aged and infirm gardener; both recommended by respectable gardeners holding first-rate situations, and by the clergymen of their respective parishes. At the same meeting, a donation of ten guineas was received, together with a few minor donations, two life subscribers, and a dozen annual subscribers. A vote of thanks was passed to such proprietors and editors of botanical and horticultural periodicals as had published the Rules and Regulations of the Society gratis; and a hope was expressed that the practice would be continued and extended, at least for some time, till the Society obtained ample funds. — *Cond.*

SCOTLAND.

Cottage Windows.—The Highland Society of Scotland, desirous of contributing by every means in their power to improve Scotch cottages and their gardens, has offered premiums for the “best and approved” cottage window. This will probably do much good. Scotch cottages are in general miserable hovels, and their windows small square holes with a fixed frame containing four panes, not made to open for ventilation. — *Cond.*

Irrigating Meadows with Liquid Manure.—This has been done to a considerable extent for some years past close to Edinburgh, by causing the liquid part of the contents of the common sewers to flow over certain low-lying grass lands. The effect has been most injurious, both to the inhabitants adjoining these irrigated lands, by contaminating the surrounding atmosphere, and to the animals which feed on the grass produced, by destroying in a short time the digestive powers of their stomachs. A very interesting pamphlet has been published on this subject, entitled, *Papers relating to the noxious Effects of the fetid Irrigations around the City of Edinburgh*, 8vo, 1839, A. and C. Black. By this tract it appears that no horse or other animal will eat a particle of the produce of these meadows, either while growing, or when first cut; and that cows “when first put to eat it have for some days an absolute loathing, and can hardly be got to feed upon it; but when they do, it causes an immense flow of milk, which is kept up by this grass, and what is called dreg [brewer’s wash]; but whenever the supply of this grass becomes short, they are found to be incapable of digesting the usual fodder of cattle, and completely diseased, and get unfit for any purpose almost.” It is lamentable to think that either individuals or public bodies should have it in their power to tamper with the public health, in the manner which appears to have been done at Edinburgh for some years, by the irrigation of these meadows; but we trust the practice will in a short time be put down. — *Cond.*

ART. III. Caledonian Horticultural Society.

THE Spring General Meeting of this Society was held in the council room, at the Experimental Garden, Inverleith, on the 5th of March, Duncan Cowan, Esq., in the chair. The show of flowers and fruits was not extensive; but the specimens were select, and in general excellent.

For fine varieties of *Camellia japonica*, two premiums were awarded: the first to Mr. John Addison, gardener to the Earl of Wemyss, Gosford House, for *C. Donckelæri* and *imbricatâ*; and the next to Mr. John Young, gardener to Thomas Oliver, Esq., Newington Lodge, for *C. Donckelæri* and *Vandèsia cârnea*. A curious specimen of Gray’s Invincible *Camellia*, reared by Mr. Kelly, at the Inverleith Nurseries, having two kinds of flowers on the same stem, attracted much notice. All these plants were in pots; but there was also a rich collection of cut flowers, consisting of 18 varieties, from Balcarres garden, which excited great admiration. Three premiums were awarded for choice specimens of the beautiful genus *E’pacris*: the first to Mr. Addison, Gosford, for *E. nivâlis*, and a new variety of *E. variâbilis*; the next to Mr.

Young, Newington Lodge, for a large plant of *E. impréssa*, clothed with its crimson flowers, and *E. campanulata álba*; and the third to Mr. Robert Watson, gardener to David Anderson, Esq., of Moredun, for *E. impréssa* and *nivalis*. Of *Azàlea*, possessing the Chinese character, three specimens were produced, two of them particularly large and fine; for both of which premiums were voted. One was from Mr. Watson, Moredun, marked *Azàlea híbrida*, with purple flowers; the other was from Mr. James Smith, gardener to Professor Dunbar, Rosepark, and stated to have been raised by the professor from seeds of *A. phænicea* crossed with *A. índica álba*; the flowers white, but not fully expanded. The finest exotic shrub exhibited was a noble plant of *Rhododéndron arbóreum* var. β , in full flower: this was from the garden of the Earl of Rosslyn, at Dysart House, and the silver medal was voted for it, to Mr. John Blair, gardener to the earl. A premium was likewise voted for an admirable specimen of *Erica hyemális*, decked from base to summit with its violet-coloured blossoms. This was from Gosford garden.

It is rather remarkable that there was not on this occasion any competition in tropical *Orchídeæ*, although the cultivation of that interesting tribe is now pretty general, wherever stove heat can be commanded. Ample amends was made, however, by the exhibition, in the central window of the council room, of a very well grown specimen of *Dendròbium Pierárdi*, from the Society's hot-house, under the management of Mr. James M'Nab, the specimen being treated as an air plant with long pendent shoots hanging as from the branch of a tree, and at present adorned with its delicate pink tinged flowers.

A premium was voted to Mr. John Macnaughton, gardener to John Wauchope, Esq., of Edmonstone, for a collection of ornamental plants, including two seedling camellias raised in 1833, and now first showing flower; and also a large flowering specimen of *Acàcia hastulata*, raised from seed received from King George's Sound.

There was, this season, a deficiency in the show of dessert pears. A premium was, however, assigned to Mr. James Simpson, gardener to Captain Wemyss, M.P., Wemyss Castle, for very good samples of *Beurré Rance*. In apples, several competitors appeared, and the fruit was uniformly in high preservation. Three premiums were awarded: the first to Mr. William Thom, gardener to David Anderson, Esq., of St. Germain's, whose kinds were, Red Cluster, Ribston Pippin, Fulwood, Pomme-roy, Orange Blenheim, and Spencer Pippin; the next to Mr. William Sharpe, gardener to Sir John Stewart Richardson, Bart., of Pitfour, the sorts being Yorkshire Green, Ribston Pippin, New Ribston, Golden Pippin, Nonpareil, and Winter Redstreak; and the third to Mr. William Rintoul, gardener to James Balfour, Esq., of Whittingham. Two baskets of Mushrooms, affording examples of two distinct varieties of *Agáricus campéstris*, were honoured with rewards: the one set was raised by Mr. Macnaughton at Edmonstone, and the other by Mr. Brewster at Balcarres. A basket of the tubers of *Tropæolum tuberòsum*, of large size, was sent from the garden of the Dean of Faculty at Granton, and a premium voted to Mr. John Reid, who raised them. It does not appear probable, however, that this root will come into esteem as a culinary article.

A letter from M. René Langelier, nurseryman, near St. Helier, Jersey, was read, announcing a present to the Society's garden of more than 100 fruit trees, including all the most choice pears cultivated in the Channel Islands. Dr. Neill stated that the trees had arrived in safety, and that the superintendent, Mr. James M'Nab, had ascertained that 76 of the sorts were new to the Society's collection. A medal was voted to M. Langelier, and his name was immediately enrolled as a corresponding member of the Society. Various seeds of the culinary plants cultivated in Sennaar and Kordofan, brought home by Mr. Holroyd, the traveller, were presented by Professor Don, of King's College, London, and thanks voted.

Several communications on horticultural subjects were then read by the secretary; particularly on a mode of preventing and of curing mildew and green fly on wall-fruit trees (by means of a paint composed of flower of sulphur

and soft soap), by Mr. Sharpe, Pitfour; on the cultivation of *Chrysanthemum sinense*, by Mr. Macintosh, Archerfield, who excels in the management of that splendid winter flower; and remarks on the most hardy and productive fruit trees known in Lancashire, by Mr. Garnett of Clitheroe.—*P. N.*

ART. IV. *Retrospective Criticism.*

ERRATUM.—In p. 229. line 1., for “inverted cylinder” read “inverted cone.”

Remarks on Mr. Penn's Mode of Warming and Ventilating.—The excellence of Mr. Penn's method of warming and ventilating buildings appears to consist in the very uniform degree of moisture which it produces in the atmosphere. The heated air which enters the house has already received a dose of moisture nearly sufficient to saturate it, and has not to seek its moisture among the plants, as is generally the case. In most plant-houses the pipes are placed under the front shelves, at a considerable distance from the floor, and the atmosphere is moistened by syringing the plants, or throwing water on the floor and shelves. How greatly the state of an atmosphere so produced differs from that of Mr. Penn's houses, a little consideration of the annexed sketch will show. It is the section of a house heated by pipes under the front shelves; and it must be borne in mind that the capacity of air for moisture varies with its temperature, so that air which was saturated at 56° becomes very dry when heated to 70° .

The sketch, *fig. 41.*, is the section of a house heated by pipes under the front shelves. The arrows (numbered) indicate the course of the current of air. At No. 1. the air comes heated from the pipes (*p*) and extremely thirsty; at No. 2. it finds moisture among the plants, and rising from the damp and warm shelf (slate, of course); at No. 3. it has parted with some of its heat; it is now supersaturated, and is parting with its moisture deposited on the glass; at No. 4. it is in the same state;

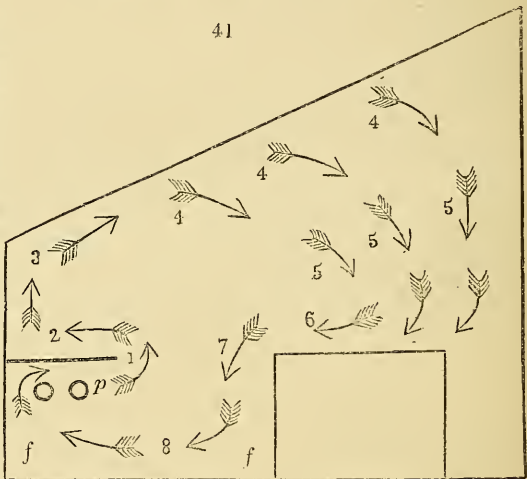

at No. 5. it has ceased to lose heat or moisture; at No. 6. and 7. the same; at No. 8. it again comes within the influence of the pipes, and is heated, becoming again very dry. Now the air which descends to the floor (*ff*), in the first place, is a small and feeble current, and, secondly, is nearly saturated, so that it can take up little moisture; what little it does get is because the floor, being slightly warmed by the radiation of the pipes, warms, and at the same time moistens, the air; but, nevertheless, the air at No. 1., in which air a visiter walks, is anything rather than saturated. My belief is, that air nearly saturated is always agreeable to the feelings. Dry air, which is absorbing moisture, is anything but agreeable. Hence the unpleasant sensation in orchidaceous houses, Now it is unnecessary to show how Mr. Penn's plan obviates all

these defects, and produces a uniformly saturated atmosphere which must be wholesome alike to plants and men.

There is a fact, which I have often observed in a small stove devoted to the cultivation of Orchideæ, which rather confirms this theory. This stove is furnished with most abundant appliances for moistening the atmosphere; about 15 square feet of water surface to 80 sq. ft. of glass. Of this water surface, 8 ft. are always at from 100° to 145° ; the remainder varies from 80° to 85° , being warmer than the house both by night and day: and all this is above the level of the heating pipes. The atmosphere, therefore, is, I believe, damper than that of almost any other orchidaceous house in England; and at this season the leaves of the plants are every morning covered with an almost tropical dew, standing in large drops all over them. Now in this stove, when the awning is on, and radiation from the glass, and consequently deposition from the air, much impeded, a temperature of 80° is by no means unpleasant. In five minutes after the awning is off, that same atmosphere becomes most oppressive, I believe because it has lost a portion of the water which it held in solution. — *J. R. Sevenoaks, April 9. 1840.*

On Mr. Penn's Method of Ventilation, and Mr. Rogers's Conical Boilers. — The discovery of the best method of heating buildings being a subject of great importance in horticulture, I have perused with much attention and interest the several articles in your valuable Magazine for March, and I beg to offer the following remarks, as the conclusions of a practical man.

I have always been of opinion that the healthiness of plants, and their complete development and perfection, are best secured by a moderate degree of ventilation, in opposition to that plan which would assert perfection to consist in keeping plants without any change of air whatever. I am, however, at a loss to understand how this is accomplished by Mr. Penn's process.

From your description, and the diagrams which are given, no change whatever can occur in Mr. Penn's arrangement, which merely provides for the continual reheating of the same air over and over again. If this be the case (for no mention is made of any method by which the foul air can escape), in what does this plan differ from every other method of heating by hot water? In all buildings heated by hot-water pipes, there must, of necessity, be a constant motion in the air; for those particles of air which come in contact with the pipes become expanded by the heat, and rise upwards, their place being supplied by colder and more dense particles. A continual motion is thus kept up in the whole atmosphere; for such is the extreme mobility of the particles of air, that a current, however small, established in any direction, will draw into its vortex many thousand times its own bulk of the same fluid.

If, then, the plan affords no change of air, and only produces a circulation among its own particles, similar to that effected by other arrangements, in what, allow me again to ask, does its excellence consist? From the encomiums passed upon it by you, I am disposed to think I misunderstand you; and, if so, shall feel greatly obliged, in common, no doubt, with many others of your readers, if you will set me right.

But there are other reasons why I am disposed to doubt the superiority of Mr. Penn's plan. By placing the pipes in a drain or tunnel, it is certain that the heat cannot be so regular as when the pipes are distributed in the house itself; nor can the same amount of surface produce the same temperature, as, when they are exposed, the air begins to rise with the smallest possible increase of heat.

It is certain that less than one degree of heat will cause the air in contact with the pipes to ascend; but, when the heating surface is enclosed in a drain, it requires a much greater force of heat to cause its ascension, on account of the diverging currents which are produced, and the friction of the air in passing through the various gratings, tunnels, and apertures. This is exemplified in many cases where large buildings have been warmed by a hot-water apparatus placed in the basement, and the heated air is brought into the

rooms through gratings placed in the floor. The same effect must take place in this apparatus of Mr. Penn's; and I feel convinced, by practical experience, that it is impossible to produce such a high temperature and so uniform a heat by enclosed pipes, as by those which are freely exposed in the building. Another advantage claimed for this apparatus appears to me more than doubtful. It is stated that, by throwing water into the tunnel, any degree of moisture may be imparted to the air; but on this subject I would remark that air absorbs moisture only in proportion to its heat; and, as in this case it is heated by the pipes after it has passed through the tunnel, it does not appear to me that it can ever be saturated by this means.

The sixth and last claim which you state this plan has to public notice is, that, "in the atmosphere of London, where the air is charged with soot and smoke, Mr. Penn's improvement will admit of forming a green-house or stove, with much purer air than can be obtained by admitting the external atmosphere according to the usual means of ventilation, which will not only be better for plants, but for persons going in to examine them." This passage I do not profess to understand, and therefore can offer no remarks upon it; for it appears to me, that, as Mr. Penn draws the air required for ventilation from the external air, that which he thus uses must be the same as is obtained by other people.

With respect to the Conical Boiler of Mr. Rogers, I would also offer a few remarks. Your correspondent, Mr. Beaton, states that when this boiler was first used it was in the form of a vertical cylinder, "which did not answer perfectly, wasting much heat:" but, in another part of his letter, he states, "there is great inconvenience experienced by the formation of steam, and he therefore thinks it will be better more of a cylindrical form," that is to say, of the very form which experience has shown wastes much heat. It would, therefore, appear, that either Scylla or Charybdis must be our fate, when we use this boiler.

Mr. Rogers has himself, with the greatest fairness, noted several of the inconveniences which attend the use of his boiler, and which have induced him unwillingly to relinquish the old form for that proposed by Mr. Shewin. These inconveniences, he states, were, the liability to derangement, and damage to the grating, as also the rapid wear of the copper boiler. If then, on the evidence of the avowed advocates for this kind of boiler, we find that, in order to avoid a paramount evil, we must adopt a shape which wastes much heat, that is also liable to get out of order, and that has sometimes been found "corroded in a few months by the sulphur disengaged from the coke," I am utterly at a loss to know why it should be so highly extolled, or to discover in what its merit consists. Of the improvement suggested by Mr. Shewin nothing certain is yet known, for it appears that at present it is quite in a crude state, and has not been sufficiently tried, to ascertain whether some greater inconvenience may not result from its use, than those which it is the object to avoid.

I cannot subscribe to the doctrine, that the economy of fuel must be greater in this than in other boilers. The theory of combustion is now too well known to lead us astray in this matter. Slow combustion and a small degree of heat, are *not* the most economical; for in this case it is known, that the carbon of the fuel is changed into carbonic oxide, which contains a considerable body of latent heat, whereas a rapid combustion changes it into carbonic acid, which is the most extreme change that fuel can undergo, and by which alone its complete combustion is effected. Another objection is, that it is only the internal surface of the boiler which is exposed to the fire. I have, I believe, seen every kind of boiler that has yet been used for hot water, and I am of opinion that no shape exceeds in efficiency the horse-shoe, or saddle-boiler. It has been proved to be equally suitable for large or small apparatus, for I have seen as much as 1000 ft. of 4-inch pipe, heated well by one boiler, and some have come under my notice, which were heated by Mr. Fowler of Temple Bar, and appeared to me to be as near to perfection as could well be imagined. I have no doubt, however, that a great

difference would arise from the mode of setting the boilers, as I have heard of some cases where very indifferent success has attended the use of them, and which, as far as I could learn, has arisen from unskilful setting. To judge from the remarks in your Magazine, it would appear that the practical application of hot water is about to undergo a complete "revolution." I was in hopes that the public opinion on such matters had become more settled, and that the notions which led so many astray, viz., that a penny-worth of fuel would give more heat than a chaldron of coals, were now quite repudiated; and really, seeing the errors which have been heretofore committed on this subject, I would caution all persons against laying aside inventions of tried and acknowledged excellence, for every new-fangled theory which happens to be propounded.

I am perfectly unprejudiced towards any plan and I should therefore be glad to have any errors pointed out into which I may have fallen; but, until this be done, I prefer adhering to those plans which I know succeed perfectly, in preference to adopting problematical and even fanciful advantages. — *William Anderson. Brixton Hill, April, 1840.*

The Grand Conservatory at Chatsworth.—I quite agree with Mr. Forsyth in his strictures on this structure (p. 103.), and on the ridge-and-furrow method of roofing and glazing. If it be an improvement to consume more glass, more wood, more paint, to subject the woodwork and putty to a better chance of decay, to afford a good berth for a heavy fall of snow, why then it is perfection; but not otherwise. The greatest improvement that I know of in hot-house building is, glazing with lead instead of putty, and consequently only exposing the sides of the sash-bars to the weather. — *Amicus. Feb. 6. 1840.*

Habits of the Jackdaw.—I have lately read some of Mr. Waterton's articles on ornithology, and have been much interested by the admirable manner of his writing, though I cannot pretend to much acquaintance with such subjects. It would be well if other writers on subjects of natural history, and especially on botany, would imitate the simple natural style of Mr. Waterton, which renders such essays infinitely more entertaining, than the rigid adherence to scientific and technical terms and forms of expression. Among his many interesting descriptions of various birds, Mr. Waterton has given a delightful account of the peculiar habits of the jackdaw. He calls our attention to what appears a great want of sagacity in this bird; the fact of his many vain attempts to introduce his sticks into the hollow where he begins his nest. "You may see the jackdaw," he says, "trying, for a quarter of an hour, to get a stick into the hole; while every attempt will be futile, because, the bird having laid hold of it by the middle, it is necessarily thrown at right angles with the body, and the jackdaw cannot possibly perceive that the stick ought to be nearly parallel with its body, before it can be conveyed into the hole." Against this charge of defective knowledge in the jackdaw, it is my present object to defend him to a certain extent. Like the rook, the jackdaw begins his nest with pretty strong sticks; these he lays hold of by the middle, obviously because he can thus support their weight best in his flight. It often happens that the hole into which he tries to introduce the stick is small, while there is no branch near it for him to perch upon, for the purpose of altering the direction of his stick. He tries again and again to get the stick into the hollow, and, if it does not either bend or break, he must let the stick fall, and abandon his purpose, since he cannot use his claws in the hole to alter the position of the stick. Those who have seen the jackdaw begin his nest in a chimney, would give him credit for ingenuity in carrying his sticks horizontally; for this enables him to drop them down in the only way in which they could become fixed for his purpose; and in no place does he make so complete a nest, as in a chimney. Mr. Waterton had recourse to a very ingenious expedient to induce his rooks and jackdaws to build on the same tree. He made a cavity in an old elm tree, and a pair of jackdaws took possession of it, while the rooks built on the top of the same tree. I knew of an instance at the seat of the Earl of Leven, Melville House, Fifeshire, where both these

birds built in the same tree, of their own choice. It was a large beech, and in a cleft near its top the rooks had accumulated a quantity of nests, while several jackdaws had taken possession of the lower part, and there reared their young. This double colony on the same tree had a most singular appearance. Mr. Waterton says that, perhaps, there is no instance on record of the jackdaw ever building its nest, like the rook, in the open air. I knew, however, of such an instance, which occurred in the place already mentioned. The Earl of Leven had some work done at his mansion, which drove the jackdaws to build their nests in rabbits' burrows, and on spruce fir trees. The jackdaw showed but little sagacity or contrivance, when reduced to build on these trees; but, as in the house, piled up a vast quantity of materials very loosely together. The trees where the jackdaws built grew in a thick plantation, and I well remember the joy I felt with other boys of my age, when we discovered jackdaws instead of rooks.—*John Wighton. Cossey Hall Gardens, Feb. 12. 1840.*

Joyce's Stove is made up of two concentric cylinders, the inner one being the furnace part; it gives out more heat from a given quantity of fuel than any other stove with which I am acquainted. From this stove I borrowed the idea which led me into the error which is kindly corrected by W. of Darlington at page 227. Mr. Rogers also pointed out to me, in a private letter, the error into which I had fallen. I am obliged to both gentlemen for their leniency, and I consider that I was fortunate in falling into such respectable hands.

I wish Mr. Rogers had given as full directions for mixing and using the cement with which the joints of the pipes are made, as he has given for putting up and managing his boiler. This would enable every gardener in the country to put up the apparatus with the assistance of a blacksmith. I ought to know all this, having superintended the making of very many joints for the last ten years; but I quite forget the proportions now, and I mix all my cement by guess.

In fixing the pipes for any close boiler, the first length, and sometimes the first two lengths, of the top pipe are placed higher than the boiler, in order to prevent a vacuum in the top of the boiler, where steam would soon generate. In the old close boilers of large dimensions, I used to rest satisfied if the top pipe were a few inches above the boiler; but, as the highest part of the pipes in all cases may be considered in effect to be the top of the boiler, perhaps the higher the pipes are placed above the conical boiler they may give a proportionate capacity to it, and thus account for the disproportionate height of the pipes recommended by Mr. Rogers.

A small iron pipe, 5 or 6 inches long, and an inch or half an inch in diameter, fixed upright in the highest part of the top pipe, is more simple than an air-cock, and answers just as well for letting the air out of the pipes, and allowing the water to expand. From this point the top pipe should dip towards the farthest end, if only 1 in. in 50 ft., and the under pipe should incline back all the way to the bottom of the boiler. I dislike elbow turns at the end of the pipes for many reasons; and I should always have a cistern there when practicable, if ever so small, with a close lid to it. This cistern is the proper place to supply the pipes with cold water when the boiler is at work, and if a small pipe could be conveyed to it from a rain-water butt or cistern, with a ball-cock, it would be the handiest thing in the world. I never like to add cold water to a boiler at work, and I do not think it is right to do so. During the growing season of plants, I should keep the cistern open to discharge its vapour into the house or pit, and when it was desirable to have a dry atmosphere for ripening off grapes, pines, and other fruits, the lid should be kept constantly on.

If Mr. Penn would use small cisterns in his system, and have them so arranged, that one cistern would come in at the centre of each of his air drains, it would be a considerable improvement; there would not be any necessity then for chilling the air of the house by throwing down cold water

into the drains; the upward currents would carry off the vapour constantly rising from the cisterns. Mr. Rogers might do the same thing in his new pit. The only difficulty arising from such an arrangement would be when dry air was wanted for ripening fruit, but that might be easily overcome.

Speaking of vapour puts me in mind of the steamer I recommended for steaming-houses in summer, when the fires were not at work, and for using tobacco vapour instead of tobacco smoke. I am glad W. (p. 228.) approves of it. I only wish he had given the weight of his full name to his communication.

Mr. Shewin is now getting one of these steamers ready for us, and I shall soon test its operations, and report accordingly; meantime, I will only add that steam being nowadays so fashionable, it would be worth while to have one of these steamers, if it were only for being so far in the fashion of the day. Every one says he likes travelling by steam; for my part I do not like sailing, or rather paddling, by steam, it helps the king o' a' diseases, sea-sickness. Six weeks after my last trip to Inverness I was on London Bridge, and, seeing the tide coming up, I turned sea-sick at the sight of it, and I was obliged to run out of the way. I hope it will be just so with the green fly and other insects; after they get a trip or two of my steamer, the very sight of it will make them leave the house. But laying this aside, no one, I think, will deny that a volume of dense vapour will be more congenial to plants in a summer's evening, than syringing them overhead with cold water to chill them down for the night. When the superiority of this system is once understood by cultivators, syringing will only be resorted to for clearing the foliage now and then.

The best gardeners are, generally speaking, the greatest advocates of the syringe; yet they all know it has its disadvantages, for unless in the hands of a very trusty workman, the syringe often does more harm than good, by giving equal quantities of water to the more tender plants with the stronger kinds, and thus soddening the pots of the weaker party to the eminent danger of their existence; just as a young tyro in the watering way would give every pot he would come to an equal quantity of water.

Now, for using tobacco by this steamer, What is the simplest mode of getting the strength out of common or home-grown tobacco by means of water? or, or speak technically, How is the narcotic principle to be extracted from tobacco leaves? There is an account somewhere in this Magazine, where tobacco liquor was used with the syringe, after adding five gallons of clean water to one gallon of the liquor, or some such proportion. In using this liquor, it must be first strained, to keep the sediment from clogging or otherwise injuring the steamer. As tobacco liquor is so cheap, perhaps it will be found cheaper than growing tobacco for this purpose.—*D. Beaton, Kingsbury, April, 1840.*

Pinus Pinsäpo and *P. cephalónica*. — Perhaps it may be interesting to such of your readers as are not already aware of the fact, to learn that these two species are as different from each other as any two species of a genus need be. The seedlings of these species produced only their seed leaves in most places round London last year; their seed leaves were so much alike that fears were entertained of their being only one and the same thing; but now that they have made some growth, they assume two distinct characters, the Cephalonian fir belonging to the section *Picea*, and the *Pinsäpo* to that of *Abies*. — *D. B. Kingsbury, April, 1840.*

Mr. Lymburn on the Potato. — Mr. Lymburn's excellent paper on the potato (p. 210.) puts me in mind of a notice I have intended to send to you, for many years past, on the same subject. When I was "turned" fifteen years of age, I used to go to grouse-shooting in the Highlands, for several successive seasons, in the suite of the present Lord Lovat. When our vegetables "run short," we used to buy potatoes from a shepherd, near whose hut we used to pitch our tents. These potatoes were grown every season on the same piece of ground. The last season I was there,

the shepherd told us that that was the sixteenth season he grew potatoes on this piece of ground without any intervening crop; and, from enquiries I have made lately, I find this system of cropping was carried on for five and twenty years, when the old man left the glen. His successor made a great innovation on the old man's system of cropping, by sowing barley alternately with the potatoes. The piece of ground was from half to three quarters of an acre. I could not find out the average quantity of produce, but the sample could not be excelled anywhere.—*D. B. Kingsbury, April, 1840.*

Inaccuracies in the Names of Fruit Trees, &c.—In a paper by W. on the Derby Arboretum, &c., at p. 61., are some rather severe reflections upon country nurserymen, for their inaccuracies in the names of fruit trees sent out by them. Had these remarks been confined to new sorts, or to old sorts difficult to be distinguished by their wood or leaves, it might have passed unnoticed, but three sorts of those mentioned are so readily to be distinguished at all stages of their growth by their wood and leaves, that surely there is scarcely a nurseryman of any respectability in the country who could not tell whether he had got the true Ribston Pippin apple, or the Impératrice plum, or who could not detect a Brussels apricot growing amongst his Moorparkes. There are but few gardeners who could not have ascertained, also, whether they had got the above three kinds of fruits correct, without having occasion to wait for the trees producing fruit.

Any gardener who has worked for any length of time in the large fruit-tree nurseries, such as Cormack & Co's., Donald & Son's, Kirk's, Ronald's, &c., cannot help observing how readily the foremen of the fruit-tree departments can recognise many varieties at first sight, without having occasion to refer to the numbers, and often detect and root out spurious sorts when by accident they have got amongst other kinds, and in fact pride themselves upon keeping their stock genuine of the different varieties. The same observations are applicable to the respectable country nurseries.—*E. B. Birmingham, April 16. 1840.*

Yellow Clover and Black Nonsuch.—On looking over the fifteenth volume of that excellent work, the *Penny Cyclopædia*, under the article Medick, we find the writer expressing astonishment that the black medick (*Medicago lupulina*) "should be supposed to be the same as hop trefoil. This supposition," he says, "would have scarcely been credible, did we not possess evidence of the fact in one of the best of our English works on agriculture. Thinking that our *Encyclopædia* might possibly be alluded to, we turned to the article on Clovers, p. 872., where *T. procumbens*, the yellow clover or hop trefoil, and *Medicago lupulina*, the black medick or nonsuch, are both figured and described; but unfortunately we have transposed some of the common English synonyms, thus making the hop trefoil and the black nonsuch synonyms of *Trifolium procumbens*; whereas hop trefoil is *Trifolium procumbens*, and black nonsuch, or black medick, is *Medicago lupulina*, altogether a smaller plant, and known at sight by its black pods. See Smith's *English Flora*, vol. iii. p. 309. and 318., and Sowerby's *English Botany*, t. 945. and t. 971.—*Cond.*

Mr. Lymburn on the Culture and Preservation of the Potato. (p. 210.)—Mr. Lymburn is neither a superficial thinker nor a careless observer. He appears to have no wish to rest on theory, while practical facts are within his reach; and so far acts the part of a sound philosopher, especially when the phenomena of vegetation are under discussion. His principal subject is introduced by allusions to the opinions of Mr. Towers and myself relative to the pre-existence of every membrane, and of every member exhibited in the growth of a plant. Mr. Lymburn, however, unlike many other critics, candidly admits that it is more difficult to deny than it is to prove the truth of my ideas on this branch of knowledge. He hesitates to believe what I have had reason to affirm, namely, that there can be no such a thing as an adventitious bud; and his reasons for this hesitation are what he has observed as the effect of

elling a sycamore tree, and of an unusual production of clustered buds on the crown or collet of a dahlia tuber. Now, there are so many instances of the incredible number of gems or buds developable from the radical plate of a bulb, the crown of a herbaceous perennial, or from the collet or indeed any part of the stems of such trees as the myrtle, hawthorn, elm, &c., that it is rather a proof of the validity of the idea that what are called normal buds are illimitable, or indeed infinite as to numbers. If we consider the structure of a single shoot of any dicotyledonous tree, we must admit the practicability of making this divide itself into a hundred others, thereby gaining a clear idea of the accidental cause of the birdnest-like tufts of spray seen on birch and other trees; for, if the leading or topmost bud of a shoot be destroyed in the first stage of its growth, its lengthening tendency is stopped, and all the buds which would have been exhibited along the whole length of the perfected shoot will be found crowded together round the base; whence, if the tree be vigorous, they will in time be developed, and hence a group of many shoots will be produced. But, whether singly, or in great numbers, they must necessarily have the same origin.

Dr. A. T. Thomson's notion of the miscalled medullary rays being the tracks of buds is untenable; because these rays exist where no buds ever appear, as on the internodes of the grape vine, for instance: and, besides, these rays are convergent to, not divergent from, the pith; and are in fact perpendicular partitions, extending from the bottom to the top of the trunk; and with which were the buds connected, the latter would appear in perpendicular ranks one above another, and not dispersed irregularly as they usually are. The doctor's idea that the number of normal buds is definite is certainly erroneous, especially if we only consider what numbers are crowded together in the single eye of a potato. Few persons, perhaps, have proved this, as it was once my duty to do; "and thereby hangs a tale." I once served a gentleman who was a native of Manchester, and who very much regarded every thing originated in that neighbourhood. Of course we had all the crown bobs, the top-sawyers, and roaring lions from that district; among other things were received two large specimens of a famous new and scarce potato then in great estimation about Manchester. I had the charge of these precious morsels, with strict orders to make the most of them. Accordingly, it occurred to me to propagate the potatoes exactly as dahlias are now done. I nearly buried them whole in the floor of a peach-house then in work; and as the shoots sprung up 4 or 5 inches high, they were slipped off and planted in rows in the open air on a piece of well-prepared ground. The slipping and planting began in April and was continued till the beginning of July; and even then the tubers continued to produce shoots. I took no note of the number of slips obtained from each eye, nor of the numbers collectively from both tubers, but they were considerable; and I well remember having five or six rows across a quarter of the garden, which yielded a large increase of tubers, though much smaller generally than if they had been, as they were for several years afterwards, raised from sets in the common way. I mention this, as a practical proof of how very complicated a member the single eye of a potato is; and as dahlias are of similar character, it is not to be wondered at, that a tuber, perhaps of a peculiar conformation, should be studded with a swarm of buds abnormally exhibited.

The main question is, whether there can possibly be such a thing as an adventitious bud, that is, one which had no previous existence in the system. I humbly presume there cannot, and, if not one, how can thousands be exhibited? It may be conjectured that, when buds appear in excessive numbers, they must be new creations; but of what and whence are they created? That the vital membrane produces both buds and roots simultaneously is undeniable: but these are not fortuitous; they are pre-existent parts or extensions of that membrane whence all growth proceeds. The only instances we have of what may be called new creations, are the sports or variations which occur among highly cultivated seedlings, owing to the intermixture of

pollen or some other accident. But these, be it remembered, are only changes of the form or colour, or qualities of pre-existing entities; and, moreover, in many cases, it is not the seeds, but their appendages only, that are changed, as exemplified in the orange, pear, plum, &c. Mr. Lymburn adduces corroborating proofs of his positions from anatomy, and from that obscure branch of botany called morphology. I feel unable to follow him into the first; and as to the last, whoever adopts its principles can easily account for whatever irregularity may take place in the natural forms of vegetation: but on this ground any excessive birth of buds may be accounted for, though the morphologist may render himself obnoxious to the keen satire of Mr. Mudie, namely, that "organic matter is of so docile a nature, that it is more plastic than Hamlet's cloud, and seems quite ready for sea or land, for plant or animal, and may become a sea-weed or a lichen, a lettuce or a lion!"

All that Mr. Lymburn has advanced concerning the potato, both by way of comment on Mr. Aitken's statements, as well as his own opinions and instructions thereon, are excellent, and well worth every potato-grower's notice. I admire what he has written on the subject, and think it a pity so useful a paper should bear on its face any thing like uncertainty or doubt as to any other part of vegetable phenomena, with all of which Mr. Lymburn is doubtless so well acquainted. It is for this reason I have ventured to make the above remarks, and trust that these matters, as we are both in search of truth, he will take in good part, and excuse the liberty I have taken with his name. — *J. Main.* March 6. 1840.

ART. V. *Queries and Answers.*

WINTER Garden of St. Petersburg. — In an early Number of the *Gardener's Magazine*, you gave a very interesting account of the winter gardens of Berlin. Could you not get one of your correspondents to send you a detailed description of the winter garden of the emperor's palace at St. Petersburg, which, from the description of travellers, seems to be upon a most magnificent scale. The list of plants, the method of warming, the temperature kept up; all these particulars would be very interesting to your numerous readers, and to me in particular, who am building a house solely for the purpose of getting flowers to bloom in winter, roses, honeysuckles, jasmynes, &c. Mr. Penn is of opinion that without the combined influence of the sun, even his improved method of heating and ventilation will not succeed in producing the effect I wish. Directed by the article in the March Number of your Magazine, I went to Lewisham to view the various houses heated by Mr. Penn's new method, and was really astonished at the effect produced. I should judge that the garden at the winter palace of St. Petersburg must be just in its prime at this time. — *Surreyensis.* March 6. 1840.

Alton Towers. — In answer to Mr. Allen's query, we are informed by a gentleman who has lately been at Alton Towers, that travellers in their own carriages have been admitted by tickets from the inn to see the armoury, picture galleries, statuary, house conservatory and elegant suite of apartments, chapel, &c., as well as the garden, and its conservatories, umbrageous walks, and waterfalls; and respectable travellers in carriages have been admitted by ticket to see the gardens only. — *Cond.*

Moorpark Apricot. — Permit me to ask, through the medium of your excellent Magazine, if there is any stock on which the Moorpark apricot can be grafted that would obviate the disappointment of seeing nearly half the tree suddenly dying. Being in my opinion the only apricot worth eating, I feel very anxious to preserve it. — *J. W. D.* London, April 9. 1840.

THE
GARDENER'S MAGAZINE,
JUNE, 1840.

ORIGINAL COMMUNICATIONS.

ART. I. *On the Means of supplying Atmospheric Moisture to Hot-houses; including some Observations on the Use of Steam for that Purpose.* By JOHN ROGERS, Jun., Esq., F.R.S. H.S., &c.

To imitate nature in the production of artificial climates under glass three things are necessary, heat, light, and atmospheric moisture, each in its proper degree. The agency of the first two has long been known and studiously provided, the latter is less obvious; it has only lately been recognised, and gardeners have still to seek the best means of providing it. It is perhaps the most valuable practical result of the cultivation of tropical epiphytes, that they have directed our attention to the hygrometric condition of the atmosphere, and culture in general has benefited.

The causes whose constant operation renders our artificial climates unnaturally dry are principally two; the condensation of moisture on the glass, and the escape of heated and damp air through the crevices of the building, its place being constantly supplied by dry external air. A third drain of moisture formerly existed in the absorbing surfaces of brick flues, which drank up the moisture of the air in contact with them, and carried it off with the smoke into the outer air. The very general use of hot water in iron pipes has removed this nuisance, and we have now only to contend with the two first mentioned.

Some idea of the drain of moisture by the escape of heated air, may be formed from the following considerations. The capacity of air for moisture, that is to say, the quantity of water which a cubic foot of air will hold in invisible solution, depends upon its temperature, and increases with it in a rapid ratio. It is doubled between 44° and 66° . The consequence is, that every cubic foot of air which escapes at the latter temperature, carries off with it twice as much moisture as it brought in. Where the difference of temperature is greater, the drain becomes greater also: air entering at 44° , and escaping at 80° , carries off three times as much as it brought in, escaping at 90° four times. Now the escape of air from our best-

glazed buildings is considerable at all times, even when the lights are closed; and if the glazing be defective, and the laps be not putted, it is very great indeed. The amount of moisture thus abstracted cannot be very easily estimated, varying exceedingly according to the height and construction of the building heated.

There exists however another drain of moisture, constantly affecting all hot-houses, however perfectly constructed, and however cautiously ventilated, viz. the condensation on the glass. In this case the expenditure is capable of pretty accurate calculation. It has been ascertained by experiment* that each square foot of glass will cool $1\frac{1}{4}$ cubic foot of air as many degrees per minute as the temperature of inner air exceeds that of outer air: that is to say, if the temperature of outer air be 44° , and of the house 66° , for every square foot of glass, $1\frac{1}{4}$ cubic foot of air will be cooled 22° per minute; and the moisture which this air held in solution, in virtue of its 22° of heat, will be deposited on the glass, and will either drain away out of the house or fall in drip. The greater the difference between the temperatures of internal and external air, the greater will be the amount of condensation; and be it observed, that the capacity of air for moisture does not increase simply in the arithmetical ratio of its temperature, but by a scale considerably more rapid, so that the expenditure of moisture at high temperatures is much greater than at low temperatures, for equal differences between internal and external air.

To put this matter in a clearer light, and give some idea of the real waste of moisture by this means, we will take the case of a small vinery 25 ft. long, by 13 ft. 6 in. wide in the roof, maintained at 65° , when outer air is 35° , a matter of daily occurrence in early forcing.

The area of such a roof is about 350 ft. square including woodwork, and, as the glass of the ends will more than compensate for this reckoning, we will take 350 ft. as the area of glass. Every square foot will cool $1\frac{1}{4}$ cubic foot of air 30° per minute; that is to say, 437 cubic feet of air will be cooled 30° per minute. Now, air saturated at 65° contains 6.59 grains of water per foot cube; at 30° it is saturated by 2.25; consequently 4.34 grains per minute is the amount of water deposited in condensation by each cubic foot, or each square foot of glass condenses per minute 5.42 grains of water: that is to say, there is subtracted from the atmosphere of such a house 1897 grains of water per minute, or very nearly a quarter of a pint; that is, 14.8 lb., or nearly one gallon and a half per hour. Hence in 24 hours, if the temperature be maintained as above, there would

* See Hood's Treatise on Warming by Hot Water, art. 145.

be subtracted by condensation alone from a saturated atmosphere $35\frac{1}{2}$ gallons of water.

It is true that a saturated atmosphere is not constantly maintained, nor is to be desired in forcing-houses, but it will be observed that in this estimate no allowance is made for escape of heated air, which would probably more than compensate for the difference between a saturated atmosphere, and that which ought to be maintained in a forcing-house. In the cultivation of *Orchideæ*, the atmosphere must be kept at a state much more nearly approaching to saturation, so that for this purpose the foregoing estimate of waste by condensation will probably not exceed the truth.

It may, however, be possible to obtain a somewhat more accurate calculation of the amount of condensation which will take place, supposing the atmosphere of a forcing-house, as above described, to be maintained at a moderate and natural degree of moisture. In the absence of more exact data, we may fairly take the mean degree of dryness of April, May, and June, the growing months, as indicative of the mean degree of dryness which ought to exist in a forcing-house. And in the absence of observation, which might enable us to deduce a hygrometric mean, we may take as an approximation the mean dryness, as observed daily at 9 A. M. at the Royal Society's apartments in London.

It may be observed, that during these months the variation between dryness and dampness during the twenty-four hours is at its utmost. The atmosphere being supersaturated during eight or nine hours of night, and exhibiting various degrees of dryness during the day. The dryness at 9 A. M. is undoubtedly greater than the mean dryness of the twenty-four hours, but it may be fairly assumed to represent a state of atmosphere wholesome to vegetation. It appears that the mean dryness, i. e. the difference between the temperature and dew point for April, May, and June, 1838, was as follows:— April, mean at 9 A. M. $6^{\circ} 8'$; May, $8^{\circ} 5'$; June, $5^{\circ} 1'$: giving a mean of $6^{\circ} 8'$, say 7° . Now, if a mean degree of moisture, corresponding with this, be kept up in the forcing-house above mentioned, the difference between the dew point of the house and the temperature of outward air will be 23° ; therefore, the quantity of moisture condensed per minute will be the difference between that which will saturate 437 cubic feet of air at 58° , and that which will saturate the same volume of air at 35° , the supposed temperature of outward air, when the stove is 65° . Now, this quantity is 1289.15 grains, rather more than two thirds the amount which would be condensed from a saturated atmosphere, or about one gallon per hour.

Having ascertained, or at least obtained, some approximate estimate of the waste of moisture which takes place from the atmosphere of our hot-houses, it remains to devise the best method

of procuring a constant supply, proportional to the expenditure. This end seems to be most effectually attained by cisterns on the pipes, whose temperature varying with that of the pipes themselves, the evaporation from them is greatest, when the pipes are hottest, i. e. when the greatest degree of artificial temperature is being maintained, when the drain upon the atmosphere by condensation, &c., is also greatest.

After several experiments, I believe that zinc cisterns fixed on the pipes will be found the most effective and commodious contrivance for this purpose. The troughs occasionally provided are objectionable only in as far as they are much too small, and yield a brief and scanty supply; and if their size were greatly increased, they would render the pipes very heavy and cumbersome. The annexed sketch (*fig. 42.*) represents the troughs or cisterns which I have employed, which may be made at small expense.

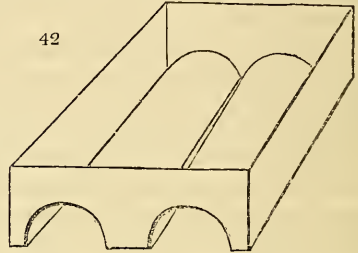

My pipes are placed side by side, and the cistern, which is 1 ft. wide, embraces both of them. It is 6 in. deep to the top of the pipes, and is fitted to their curvature to the depth of $1\frac{1}{2}$ in. or 2 in. more. These cisterns being properly fitted, and luted on the pipes with wet sand, the water in them will reach a temperature of 140° — 145° , when the pipes are at 200° ; but the smallest interstice makes a great difference in the heat transmitted. With respect to the surface of cisterns required in any given house, I am not prepared to speak with certainty; but I find that cisterns fixed in the manner here described, whose temperature varies from 120° to 145° , evaporate about an inch and a quarter, or rather more, per 24 hours, or about $\frac{3}{4}$ of a gallon per square foot of surface; so that a computation may easily be made of the number required in any given house to produce a given effect. The proportion which I employ in an orchideous stove is about 1 square foot of evaporating surface, to 10 square feet of glass; but innumerable causes will affect the result in such a degree, as to make the quantity requisite for any house a matter rather of experiment than calculation, although calculation may afford some approximate estimate. The length of the cisterns is limited only by the extent of smooth surface in the pipes. It would be difficult to fit a cistern to the rings on the pipe; and, as these occur at every 3 ft., 2 ft. 8 in. or 2 ft. 10 in. is the utmost convenient length for a cistern. It will also be perceived, that in this arrangement the pipes should lie side by side, which is always the best where practicable; where they are one

over the other, the cisterns must be narrower, and of course more are required; indeed, in this case, trough-pipes would probably be found most convenient.

In orchideous houses and plant stoves, slate cisterns placed above the pipes may be advantageously employed to increase the moisture, but they never reach the temperature of the zinc cisterns, seldom exceeding 80° or 85° ; they require, therefore, to be larger, and more numerous. Such cisterns are admirably adapted for water plants; and a range of them extending along the whole front of a hot-house instead of shelves, would be a most useful as well as ornamental addition.

Having pointed out what I conceive to be the best method of supplying moisture to the atmosphere, it remains that I should say a few words on other methods of attaining the same object; and first of steaming, an operation which at present seems to be greatly in vogue.

By steaming, I mean the discharging into the atmosphere of a house, in large quantities, the steam of water heated to boiling in a close vessel; it is difficult to conceive how an operation so exceedingly unnatural should ever have been devised, except from a conviction of the extreme necessity of moisture, and the inadequacy of all the ordinary means employed to provide it. The device proved, at least, that gardeners began to be conscious of the unnatural dryness of the atmosphere of their houses, and anxious for any expedient, however unnatural, to counteract it; and, considering the state of many plant houses, it is not surprising that its effects, as occasionally employed, should, for a while at least, be apparently beneficial. Food, though scalding hot and rather unwholesome, is better than absolute starvation to plants as well as men; but, nevertheless, it is my firm conviction, that steam is invariably injurious in a greater or less degree, and will speedily be found so, even by those who at first have had every reason to be satisfied with its effects. I have repeatedly tried it myself, under divers modifications, and have never failed, sooner or later, to perceive its most injurious effects. Indeed, its injuries are for the most part not long in manifesting themselves. The only case in which it is not evidently injurious is in large houses, where the volume of air is great, and the steam is converted into vapour long before it reaches the plants. For it must ever be borne in mind, that steam from close boilers, and vapour from water heated in open vessels, are essentially different things. Both are alike liquids, and both aeriform, and there the resemblance ends. Caloric in a sixfold proportion has entered into the composition of steam, in the form of latent heat, which is discharged among the plants, when the steam is reconverted into vapour.

The only modification under which I can recommend this

steaming process is the following, and it is admissible only because steam is no longer employed. A shallow cistern, about 6 in. deep, and carrying at least 4 square feet of area, with a false bottom of wire or pierced zinc about 1 in. from the real bottom, being provided, the steam pipe from the boiler should be introduced, so as to discharge itself between the real and false bottom; the cistern should now be filled with water nearly to its brim, and the steam laid on. The water will soon be raised to a pretty considerable temperature, and yield an abundant supply of innocuous vapour. This operation may be continued at pleasure, the cistern being filled up as it wastes. Of course, the size of the cistern must be regulated by the size of the house, and my experience is not sufficient to enable me to say what is desirable, but certainly less than 4 square feet would be useless in an ordinary hot-house, say 25 ft. by 13 ft. 6 in.

I may, perhaps, be charged with inconsistency in providing a steaming apparatus to the conical boilers, holding, as I do, such opinions concerning the use of steam. But, under the modification above described, I can conceive some advantage may be derived from its employment; and I believe it has a tendency to destroy insects: moreover, I think it possible that Mr. Beaton's suggestion of employing steam impregnated with tobacco or sulphur might be found advantageous; so that I was willing to afford those who are favourable to such experiments the means of making them. I have a steam pipe to my own boiler, and used occasionally to employ it in the above manner, but often perceived harm, and certainly never could discover any good effect from it; and now having adopted the use of the cisterns above described, I obtain a far more copious moisture than I could procure by any quantity of steam, which should not absolutely boil my plants. This moisture is produced just when I want it, without trouble. During the summer season, the portable steaming apparatus suggested by Mr. Beaton might be found useful, but always under the form above suggested; and, even in this case, I believe that a good sprinkling of water over the floor and flues, hot from the heat of the day, would produce the same effect much more safely. In orchideous houses one is seldom without fire even in summer.

The effect of the zinc cisterns is most satisfactory and natural. At the present season (April 30.), there is a constant fire in my orchideous pit, and of course a copious evaporation from the cisterns. On going into it late in the evening, the plants are found all reeking with an almost tropical dew, and every pore may drink in abundance. In the morning, as the sun's beams begin to raise the temperature, this dew disappears; and, air being

given as the day advances, the atmosphere assimilates itself in some degree to that of a tropical day; the dew point being 5° or 6° below the temperature. At night the same dew recurs, sprinkling is rendered unnecessary, and the fine rootlets, which bristle into the atmosphere like the spines of a hedgehog, preserve their extremities in full health and absorbing power. Indeed the bulbs of my older stanhopeas are buried in their own rootlets, like the birdsnest-looking masses of imported plants. I believe it impossible to provide an atmosphere more congenial to them.

There is only one inconvenience which arises from any method of moistening the atmosphere, and which of course increases in proportion to the degree of moisture produced, viz. a drip from the glass, which is often fatal to *Orchideæ*, and injures the leaves of all plants. At one time this caused me much annoyance. By the following expedient I have rendered it a most valuable auxiliary, and should be much at a loss without it. The bars of my lights being made as smooth as possible, I fix at intervals, say from 15 in. to 18 in., all down them, small pieces of cobbler's wax (putty would do as well, but is less easily removed), which cause the drip to fall wherever I please; and by thus subdividing a bar into small spaces, no one drip is excessive. But this is not all. Many of my plants are suspended on brass rods or chains, fixed from rafter to rafter, under the lights: the dripping points are arranged with reference to these, so that each plant receives a small but constant supply of moisture, which is not allowed to fall on the shoots themselves, but is generally received by a bit of tile, or a little patch of sand.

It remains that I should notice the defects of the cisterns generally employed in hot-houses, especially those intended for *Orchideæ*. Many of my friends, to whom I have recommended the use of large cisterns, have replied that such cisterns have been repeatedly tried without any good effect; and certainly I have seen large and expensive cisterns in many hot-houses from which no benefit could possibly be derived; they are generally constructed in the middle of the house in place of a pit, and are mostly of stone or cement. Now, for a cistern to be of any use, it is essential that the water should be at least 5° hotter than the mean temperature of the house; whereas the cisterns alluded to are always from 5° to 10° lower than that mean. They are formed of non-conducting materials, placed generally lower than the flues or heating pipes, and from time to time filled up with cold water, which warms very gradually; whereas, to answer any purpose, the cistern should be formed of good conducting materials, and its bottom be placed higher than the flues or heating pipes. Slate is the only material well adapted for such a purpose; a cistern built in cement, over flues or pipes, would be always

liable to leak, and, even if it did not thus fail, the flues would be inaccessible when repair is necessary. These difficulties probably deterred persons from forming cisterns in the only position in which they can be useful. Those generally employed are nearly useless except as reservoirs of water, and even for this purpose their low conducting power makes them undesirable, as the water in them is always too cold to use with advantage.

In slate cisterns such as now suggested, the much neglected tribe of stove aquatics might find a congenial habitat, and adorn our stoves. Their culture has been neglected principally I believe, because they will not flower without abundant bottom heat. They require a temperature of 75° at the least, and will bear much more; about 85° is most congenial to them: such a temperature in ordinary stoves it is difficult to give them, for they require to be close to the light, and the bark-bed, the only means of affording bottom heat, in most cases is too far from the glass. In cisterns, placed on the pipes in front of a pit, I have had them in great beauty; *Nymphæa cærùlea* with three or four flowers at once, each 6 in. in diameter, and continuing for months in succession: so soon, however, as bottom heat was discontinued, the flowers came few and unfrequent, and dwindled down to the ordinary size of those seen in our stoves.

In conclusion, for all hot-houses, whether fruiting houses or plant stoves, but especially orchideous houses, I recommend zinc cisterns on the pipes, as above described. In plant stoves I should certainly employ some slate cisterns; but, to produce the copious dews I describe, the zinc cisterns are necessary, and quite supersede the use of steam. To those, however, who may still adhere to the use of steam, I should suggest the adoption of the contrivance above described, to be employed either with a pipe from any existing boiler, or with a portable boiler constructed on purpose. The conical boiler would be very compact for this service, but it must be made of copper, or it would be most cumbrously heavy.

The foregoing observations have been thrown out rather with the view of directing attention to the subject, and assisting others to make more accurate experiments and calculations, than with any pretensions to philosophical accuracy. I have endeavoured to show that the hygrometric defects of our artificial climates may be pretty accurately estimated, and easily overcome; defects will doubtless still remain. The perfection of nature, and the innumerable compensating devices of Providence, are not to be perfectly imitated by human art; nevertheless, we may make a much nearer approximation to them than we have heretofore done.

Sevenoaks, April, 1840.

ART. II. *On the singular Origin of the Purple Laburnum, and on the new Field which it opens to the Horticulturist for the Production of Hybrid Plants.* By the Hon. and Rev. W. HERBERT, D.C.L. F.H.S. &c.

I AM much obliged to you for the opportunity you have given me of reading M. Poiteau's interesting account of the origin of the purple laburnum, or *Cytisus Adami*, which I had understood to be an accidental hybrid produced in the garden of M. Adam, but which is stated, and (I doubt not) correctly, to have originated from a graft of *C. purpureus*, of which the bud had perished. I am not aware what the hypothesis of M. Prevost and M. Leclerc, to which M. Poiteau alludes, may be; but I think I understand how this singular plant must have been produced, and, if I am right in my notion, it opens a field for the horticulturist to produce hybrid plants which perhaps could not be obtained by seed. It is asserted, that, long after the bud on the graft had perished, other small buds formed themselves round it, all of which produced the true *C. purpureus*, except one, from which proceeded the extraordinary hybrid. I apprehend, that, if attention had been paid to this phenomenon, it would have been found that the bud which produced it was formed exactly at the junction of the bark of the two species, and that the two contributed equally to its formation. A similar effect might perhaps be expected also from a bud formed where the mere bark of the graft is in contact with the wood of the stock. Every bud on a tree is an individual; and, if the graft and the stock from any peculiar circumstances contribute equally to the formation of a new bud, the individuality of that bud may be expected to partake of their joint natures, as much as that of the plant which is raised from hybrid seed. Let it therefore be the object of gardeners who wish to obtain new plants analogous to the *C. Adami*, to kill the bud of the graft after a perfect union has taken place, and to try to force the plant to break again from the seam or edge of the bark that has been inserted. Unless the bud shall be formed on the very seam, or where the bark inserted is thin, so that the bud shall have taken its rise from the contributive powers of the two plants, a new formation cannot be expected.

The circumstances attending the growth of *C. Adami* are very singular. Upon your tree one branch had reverted nearly to the type of the laburnum, and another nearly to that of *C. purpureus*, while the central shoots retained the hybrid character; but, on close observation, neither the leaves nor the flowers of the two branches, which had so reverted to the elements of the parents, were precisely similar to them; both however had acquired fertility, while the central shoots continued sterile. From the seed produced on the yellow-flowering branch, several plants

have been raised, which have the general aspect of the laburnum : but in my brother's garden one of them has grown to the height of 4 ft. 6 in., while another beside it remains only $2\frac{1}{4}$ in. high ; and, amongst those I raised, two showed a purple stain on the young wood and petioles. The seed produced on your small-leaved branch did not vegetate, but I have a seedling two years old from such a branch on my brother's tree, which has entirely the aspect of *C. purpureus*, though differing a little in the shape of the lobes of the leaves. The branches of the small-leaved variation upon his were last year loaded as with a sheet of small purple flowers, but a branch destined to bear yellow flowers having made its appearance, upon its first producing blossom this season, not a flower appears upon the small-leaved portion. Another strange circumstance has occurred, as he informs me that a strong rigid branch last year shot from the tree perpendicularly downwards, of which we must await the further development.

London, May 7. 1840.

ART. III. *On Jauffret's Manure, Quénard's Manure, Clarke's desiccated Compost, Lance's Composts, &c.* By the Hon. and Rev. W. HERBERT, D.C.L. F.H.S., &c.

I OBSERVE at p. 227. of the 22d volume of the *Annals of the Royal Horticultural Society of Paris*, which you have had the kindness to lend me, an article relating to two modes adopted by M. Quénard, of preparing manure in a mode and upon a principle said to be analogous to that which had been discovered by M. Jauffret. Having read a pompous account of Jauffret's Manure, which was said to be speedily composed from articles common, cheap, and at present useless, and to be of extraordinary efficacy, I applied two years ago to a friend at Paris to try to obtain some particulars concerning it, that I might bring its virtues to the proof; but I received for answer that a train of experiments to ascertain its value were in progress, and that the particulars of the compost could not be communicated to me.

I have very little faith in any such discoveries. Some years ago an ingredient was advertised in London under the name of Clarke's desiccated Compost, said to be a concentration of the powers of London manure, with references to many persons who could testify to its efficacy. Amongst those was Lord Grenville, to whom I applied; and he informed me that he had tried it extensively with very great advantage. Encouraged by the testimony of a person of such accurate habits, I purchased casks of it to the value of 40*l.*, besides its freight and carriage to my abode in Yorkshire. Being desirous of ascertaining its powers

distinctly, I had three rows of cabbages planted, one upon farm-yard dung, one upon desiccated compost, and one without any manure. The result was, very superior vigour in the growth of the first row, while no difference could be observed between the second and third, except that the plants which had no manure had rather the advantage. I will not take upon myself to say, that salt may not be beneficial upon some soils, or under some circumstances: but I have applied it to my wheat fields in the quantity recommended, in parallel lines with other portions of the same fields to which none was applied, and no difference was perceptible in the crops. I have also tried some of Mr. Lance's composts prepared precisely according to his directions, with absolute loss of the value of the articles, and comparative loss of my crop. I look, therefore, to all such inventions with a jealous eye, and a determination not merely to try them against other manures, but more particularly to try them against the application of nothing.

M. Quénard's plan is very simple. It consists of the union of lime, soot, and ashes (which means undoubtedly soot and ashes from burnt wood), and the immersion of straw and grass in a lie formed with those ingredients previous to their being placed in a heap, or the alternation of layers of them, applying in either case water from time to time in sufficient quantities to promote the fermentation, which is said to be complete in fifteen or twenty days, according to the temperature.

The first observation to be made upon this is, that it does not bring into use a single article that is at present either unused or cheap. Every particle of vegetable produce that can be obtained is, in this country, greedily sought by the gardener and the agriculturist, and reduced by him to manure. The reduction of ingredients to a serviceable state by the interposition of layers of lime, is a process frequently practised in all parts of this country; soot is not to be obtained at a low price, and not an atom of it is now wasted; and wood ashes being in general unattainable amongst us, if they are essential to this combination on account of the potash they contain, it would be necessary to purchase the requisite quantity of potash at a high price to complete the mixture. But here immediately arises the question, Does the union of soot and potash with lime essentially promote the decomposition of the vegetable mass, and does any benefit result to the land from these ingredients being so combined, beyond that which is afforded by the present mode of applying them? We must therefore ascertain whether the fermentation of such coarse vegetable matter as the cattle do not consume is most beneficially effected by union with the excrements of animals or with lime; and whether the action of the lime is promoted materially, and in due proportion to the expense, by the addition of potash; and, if

so, what is the smallest quantity of potash, a very expensive article, which will answer the purpose. M. Quénard's direction for making the lie is, to mix, with a certain quantity of water, five parts of ashes with three parts of soot, and, after stirring them well, to add one part of quicklime just slaked, to ten of soot and ashes mixed, i. e. 125 ashes, 75 soot, and 20 lime. The mixture is to be often stirred during twenty-four hours, and is said to be then in a state of powerful efficacy, and it is recommended to keep a portion of the old liquor to use, like yeast in brewing, to promote the fermentation of future mixtures. It is evident that experiments to ascertain the nature and value of the asserted fermentation will be most easily made by a lie, but that the process for horticultural or agricultural purposes, if beneficial, would be most easily effected by heaping the ingredients in layers. On my return to the country, I shall make some experiments as to the fermentation of lime by the addition of soot and potash, but in the meantime it seems to me desirable that you should call the attention of the public to the subject, in the *Gardener's Magazine*, or in some other of your valuable publications.

London, May 8. 1840.

ART. IV. *Botanical, Floricultural, and Arboricultural Notices of the Kinds of Plants newly introduced into British Gardens and Plantations, or which have been originated in them; together with additional Information respecting Plants (whether old or new) already in Cultivation: the whole intended to serve as a perpetual Supplement to the "Encyclopædia of Plants," the "Hortus Britannicus," the "Hortus Lignosus," and the "Arboretum et Fruticetum Britannicum."*

Curtis's Botanical Magazine; in monthly numbers, each containing seven plates; 3s. 6d. coloured, 3s. plain. Edited by Sir William Jackson Hooker, LL.D., &c.

Edwards's Botanical Register; in monthly numbers, new series, each containing six plates; 3s. 6d. coloured, 3s. plain. Edited by Dr. Lindley, Professor of Botany in the University College, London.

Paxton's Magazine of Botany, and Register of Flowering Plants; in monthly numbers; large 8vo; 2s. 6d. each.

The Botanist; in monthly numbers, each containing four plates, with two pages of letterpress; 8vo; large paper, 2s. 6d.; small paper, 1s. 6d. Conducted by B. Maund, Esq., F.L.S., assisted by the Rev. J. S. Henslow, M.A., F.L.S., &c., Professor of Botany in the University of Cambridge.

Maund's Botanic Garden, or Magazine of Hardy Flower Plants cultivated in Great Britain; in monthly numbers, each containing four coloured figures in one page; large paper, 1s. 6d.; small, 1s. Edited by B. Maund, Esq., F.L.S.

The Ladies' Flower-Garden of Ornamental Annuals; in 4to numbers, monthly; 2s. 6d. each. By Mrs. Loudon.

BALSAMI'NEÆ.

698. IMPATIENS [22.
+glandulifera Lindl. gland-bearing □] or 12 au C Nepal 1839. S co Bot. reg. 1840,

One of the four Indian species raised last year in the garden of the Horticultural Society. The seeds were sown in May, and the plants were 12 ft. high when they came into flower in August. "It is not so hardy as those with the long fruit [see our p. 145.], but flowers freely all the autumn, and is one of the most beautiful plants that can be looked upon" if grown in a moist atmosphere. (*Bot. Reg.*, April.)

Rutàcæ.

1154. CORRÆA. [vii. p. 79.
Harrisii Paxt. Mr. Harris's ■ □] or 2 apjn C hybrid 1837. C s.p.l Paxt. mag. of bot.

This splendid hybrid was raised by Mr. Beaton, now gardener to Thomas Harris, Esq., of Kingsbury, while he was gardener at Haffield, in Herefordshire, but it has flowered for the first time in the collection of Mr. Harris. Mr. Beaton, several of whose valuable papers on hybridisation have appeared in this Magazine, proceeded most carefully and scientifically with this corræa, (the parents of which were *C. pulchella* and *C. speciosa*), and his endeavours have been rewarded with complete success; the flowers of this plant being of the most brilliant crimson. It is grown in a more loamy soil than is generally used for corræas, and it is propagated by cuttings. (*Paxt. Mag. of Bot.*, May.)

Rhamnàcæ.

668. CEANO'THUS
+pallidus Lindl. pale * or 10 su Pa.B C co Bot. reg. 1840, 20.

A beautiful shrub, "much hardier than *C. azureus*," which it greatly resembles, except that the leaves are green, and not hoary beneath; and that the flowers are smaller and paler. This species was received from Bollwyller, and is frequently confounded with *C. ovatus* and *C. thyrsiflorus*, "from both of which it is certainly distinct." "It strikes readily from cuttings of the half-ripened wood in autumn, and grows well in any soil, if not too poor, or too wet." (*Bot. Reg.*, April.)

Leguminòsæ.

1964. CY'TISUS 29801 racemòsus Marnock.
Synonyme: 1663. Genista bracteolàta Link. Bot. reg. 1840, 23.

This plant, which was sent home by Philip Barker Webb, Esq., from Teneriffe, under the name of *Cytisus racemòsus*, has been since recognised by that gentleman to be the *Genista bracteolàta* of Link. (*Bot. Reg.*, April.)

Cyclògyne canescens Benth. A Swan River perennial, with the habit and aspect of a Galèga. (*B. R. M.*, No. 68., May.)

Rosàcæ.

Cotoneàster denticulàta H. B. et K. A hardy shrub, allied to *C. rotundifolia*, found in Mexico by M. Hartweg, and interesting as being "the first species of the genus observed in the New World." (*B. M. R.*, No. 58., April.)

Onagràcæ.

Lopèzia lineàta Zucc. A Mexican shrub, with pale pink flowers, which it bears in the green-house "during all the winter and early spring." (*B. M. R.*, No. 60., April.)

Philadelphàcæ.

Philadelphus mexicanus Schlect. in Linnæa 13. p. 418., and Plant. Hartw. p. 61. A Mexican plant with brown, downy, flexible branches, and somewhat cordate leaves, which are covered with coarse hairs on the under side, and are nearly entire at the margins. The flowers are large and white, and in the native specimens they are placed singly at the ends of the twigs. (*B. R. M.*, No. 70., May.)

Cactàcæ.

1472. CE'REUS
mùltiplex Pfeiff. multiplied ■ □] or $\frac{1}{2}$ au Pk South Brazil 1838. C s.p Bot. mag. 3789.
Synonyme: Echinocactus mùltiplex Hort.

A species which, like *C. leucanthus* (see p. 202.), strongly resembles an *Echinocactus*. The flowers are pink, and very large and handsome. It is a native of South Brazil; and it has flowered in England in the collection of Mr. Mackay, at Norwich. The flowers, when fully expanded, were 6 or 8 inches across. (*Bot. Mag.*, April.)

Caprifoliaceæ, or *Cornaceæ*.

Cornus grandis Schlect. A Mexican dogwood, with large dark green leaves, smooth above, and "hoary with down on the under side. The fruit seems as large as a sloe, and purplish black, covered with bloom." (*B. M. R.*, No. 59., April.)

Compositæ.

2273. *STEVIA*
breviaristata Hook. et Arn. short-awned ☐ pr 3 jy Pk S. Amer. 1836. S co Bot. mag. [3792.]

A pretty species, found by Mr. Tweedie in Tucuma, in South America, and sent by him to the Glasgow Botanic Garden in 1834. (*Bot. Mag.*, April.)

2363. *DAHLIA*
glabrata Linn. smooth △ ○ or 3 jl L Mexico 1840. S c Bot. reg. 1840, 29.

This very pretty and dwarf species of dahlia is remarkable for its smooth stems, and fang-like roots, which are slender and uniform in size, and not partly tuberous and partly fibrous, as in the common dahlia. The plant grows about 3 ft. high, and it flowers from the end of July till destroyed by frost in autumn. "It answers remarkably well if treated as a half-hardy annual, which is by far the easiest and best way to grow it; as by sowing the seed every season, there is no necessity for preserving the old roots, which are like those of the common dahlia, but much slenderer." (*Bot. Reg.*, May.)

2434. *CENTAUREA*
pálchra Lindl. beautiful ○ or 1 ju B.C Cashmere 1838. co Bot. reg. 1840, 28.

A very pretty, dwarf, bushy species of *Centaurea*, which is a native of Cashmere, and may be grown as a hardy annual in British gardens. The florets of the ray are of a very dark blue, and those of the disk of a dark crimson. In general appearance it resembles the common British blue-bottle; but it is more woolly, and the stem is much shorter, and more brached. (*Bot. Reg.*, May.)

Gesneriææ.

1701. *SINNINGIA*
Youngeana Marnock Dr. Younge's ☐ or 1½ jl P hyb. 1837. C s.l Paxt. mag. of bot. [vii. p. 51.]

A hybrid raised by Mr. Marnock, while he was curator of the Sheffield Botanic Garden, by impregnating the blossoms of *Sinningia velutina* with the pollen of *Gloxinia speciosa*, and thus combining "the subshrubby character of the *Sinningia* with the splendid purple colour of the flowers of a *Gloxinia*." It blossoms freely, and is more hardy than the genuine kinds of *Sinningia*. It should be grown in sandy loam enriched with leaf mould or rotten dung, and kept in a moist atmosphere, or frequently syringed over head. During winter, it should be kept short of water, and allowed a season of repose. (*Paxt. Mag. of Bot.*, April.)

Ericææ.

1173. *ERICA* 9669 *Lambertiàna* var. *rubescens* Bot. 163.

A very pretty variety or hybrid raised by Mr. Wilmot, at Oldford, near Birmingham, in 1835. (*Botanist*, April.)

Clèthra mexicana Dec. A Mexican evergreen shrub, or small tree, resembling *C. arborea*. (*B. M. R.*, No. 37., April.)

Arctostáphylos nitida Benth. "An evergreen bush, with serrated, shining, evergreen leaves, and short erect racemes of flowers, resembling those of the common strawberry tree." (*B. R. M.*, No. 69., May.)

Cobæææ.

Cobæa stipularis Benth. A fine species of *Cobæa*, raised from Mexican

seeds. The leaves are narrower than those of *C. scândens*, and the whole plant is more delicate. The flowers are yellow. (*B. M. R.*, No. 50., April.)
Convolvulææ.

491. IPOMŒA
longifolia Benth long-leaved Δ | or 5 j.l.s W Mexico 1838. S 1 Bot. reg. 1840, 21.

The flowers are large and white, and have a scent resembling noyau. The root is long and spindle-shaped, and the stem requires support. It flowers from July to September; and it should be grown in rich loam, in a shady situation. It is increased by seeds, or suckers of the young shoots, which spring from the crown of the root. (*Bot. Reg.*, April.)

Scrophularinæ.

480. VERBA'SCUM
tauricum Hort. Taurian \bigcirc or 2 au R ? hybrid ... co Bot. mag. 3799.

A showy verbascum with rose-coloured flowers, which blossomed in the Edinburgh Botanic Garden in August, 1839; and which, Sir W. J. Hooker thinks, "was probably sent from the German gardens to Dr. Graham." (*Bot. Mag.*, May.)

76. SÁL'VIA
linarioides Hort. Linaria-like $\#$ \square | or 1 B ? South Amer. ... s.l.p *Pact. mag. of bot. vii.* [p. 77.]

A very beautiful species of *Sálvia*, with large bright blue flowers. The plant is decidedly shrubby, and not above 1 ft. high; it retains its leaves during the winter, and flowers abundantly. It should be grown in a compost of very sandy loam and peat, and kept in a cool border with very little water during winter, as it is apt to throw out weak and sickly shoots if stimulated too soon. It is propagated by cuttings of the young wood struck in spring. (*Pact. Mag. of Bot.*, May.)

Proteacææ.

316. GREVILL'EA 2609 dñbia *Bot. Mag. t.* 3798.

Betulinaææ or *Amentacææ.*

A'lnus jorullensis H. B. et K. A fine species of alder, with large oval acuminate leaves, the veins of which are prominent, and which are downy on the under side. A native of Mexico. (*B. M. R.*, No. 52., April.)

Garryacææ.

Gárrya laurifolia Hart. A new species from Mexico, which appears handsomer than *G. elliptica*. Only one seed has germinated in the Horticultural Society's Garden. Mr. Hartweg has found "no fewer than five" new species of *Gárrya* "during his travels in Mexico." (*B. M. R.*, No. 53., April.)

Orchidacææ.

2523. CYMBI'DIUM
pendulum Swartz pendulous $\#$ \square | or 3 au Y.r.w Nepal 1837. O r.w.p Bot. reg. 1840. [25.]
Synonymes: C. crassifolium Wall., Epidéndrum pendulum Roxb.

The flowers are of a dingy yellowish brown, with a red and white labelum. "As they hang downwards, the plant should be suspended from the roof of the stove." The leaves are 2 or 3 feet long, and very stiff and leathery. (*Bot. Reg.*, May.)

2526. BRÁSSIA 29587 Lanceana var. *viridiflora Bot. Mag.* 3794.

Brássia verrucosa Lindl. "A plant of a particularly graceful habit." The flowers are of a greenish yellow, and the labellum is covered at the base "with green warts." (*B. R. M.*, No. 66., May.)

2553. CATTLE'YA 22726 labiata
var. *atro-sanguinea Pact. Mag. of Bot. vii. p.* 73.

A handsome variety of a well-known and splendid plant; introduced from La Guayra by Mr. Low of Clapton in 1839. It is the labellum which is of a dark purplish red. (*Pact. Mag. of Bot.*, May.)

2554. EPIDE'NDRUM
densiflorum Hook. densely-flowered $\#$ \square | pr $1\frac{1}{2}$ s Mexico 1839. O r.w.p Bot. mag. [3791.]

A Mexican species of *Epidéndrum* sent to Woburn by Mr. Parkinson, with long densely clothed spikes of whitish flowers. (*Bot. Mag.*, April.)

3593. *MILTONIA* cándida var. flavescens *Bot. Mag.* 3793.

Only differing from the species in having a yellowish white lip. (*Bot. Mag.*, April.)

3597. *MONACHANTHUS*
roseo-álbus *Hook.* rose and white £ □ or 2 ap R.w Brazil 1839. O s.p. Bot. mag. [t. 3796.]

An orchideous plant from Brazil, with long racemes of curiously shaped flowers, the lip of which is edged with long deep red fringe. After describing the species, Sir W. J. Hooker observes that he has “preserved the generic name of *Monachánthus*, rather from consistency than a conviction of the soundness of the genus. It might, with greater propriety, be called *Catasètum* sect. *Monachánthus*.” (*Bot. Mag.*, May.)

3728. *ODONTOGLOSSUM*
maculátum *Lindl.* spotted £ □ or 2 au Y.B Mexico 1839. O r.w.p. Bot. reg. 1840, 30.

This species, Dr. Lindley observes, appears to be “one of the prettiest of the family, because of its large two-coloured spotted flowers and drooping habit, and it seems to have much the manner of growth and constitution of an *Oncídium*.” (*Bot. Reg.*, May.)

Cleisostèma maculosa. A vanda-like plant, with small yellowish brown and pink fleshy blossoms. (*B. R. M.*, No. 67., May.)

REVIEWS.

ART. I. *Catalogue of Works on Gardening, Agriculture, Botany, Rural Architecture, &c., lately published, with some Account of those considered the more interesting.*

Le Bon Jardinier ; Almanach pour l'Année 1840. Par A. Poiteau et Vil-morin. 8vo, pp. 1055, two engraved plates. Paris, 1840.

Another edition of one of the best standard works on gardening and agriculture published in Europe. The body of the work is stereotyped, and the additions annually made form introductions, sometimes of two or three sheets, and sometimes of only a few pages. In the present edition they extend to forty-seven pages, and their essence is as under :—

Artichoke roots may be preserved through the winter in a cellar, or in a heap of dry sand thatched, and replanted in spring. *Tropæolum tuberosum* is worth cultivating. *Céleri-rave frisé* and *Chou-rave à feuilles decoupées* are new varieties of turnip-rooted celery and borecole. *Chou de Billaudeau* (see *Gard. Mag.* for 1839, p. 568.) is nothing more than the chou colossal. *Courge sucrière du Brésil* is a new and excellent gourd. *E'chalote de Jersey*, known in Scotland as the Russian shallot, and *E'chalote grosse de M. Houtton* are recommended. *Myatt's pine* and *Elton's seedling strawberry*, *Haricot noir de Belgique*, and several other plants well known in British gardens, but still rare in France, are described; and a few plants, such as the sweet potato, better known in France than in England, are enumerated, and their merits discussed. The civilisation of the wild carrot by M. Vilmorin has been recorded before, and we have here a notice of two essays to improve the dandelion and the wild parsnep. The dandelion was blanched by covering the plants with sand. Four new sorts of potato are described; seven sorts of clover, and a number of wheats and other agricultural plants. *Urtica nívea L.* has been tried as a thread plant; and *A'bies [Picea] Pinsàpo Bois.* (see our volume for 1839, p. 339.) is described as having the seminal leaves more numerous by one or two than those of the common silver fir, and also longer, narrower, less flat, and not at all prickly-pointed like those of *P. cephalónica*.

Among the new instruments are the gardener's compass, invented by Madame Adanson; a watering-pot, for watering pots on shelves over head; a hand-bill for cutting box edgings, instead of shears; and some others, already

well known. The concluding article is on a jardin d'hiver, a new plant structure, erected by M. Fion, which is said to form a very interesting winter promenade in the midst of the trees of China and Japan.

Otia Hispanica, &c. A Selection of the rarer Plants of Spain, &c. By Philip Barker Webb. Part II., 1840, folio, pp. 8, one coloured plate. Paris, Brockhouse; London, Coxhead.

Part I. of this work is noticed p. 94.; that before us is wholly occupied with marine fuci, which are described by Dr. Montagne, and beautifully engraved and coloured. The species are *Griffithsia flabellata* Mont., *G. Schousbæi* Mont., *Gigantina gaditana* Mont., *G. conferta* Schousb., and *Dessèria interrupta* Ag.

Plantæ utiliores. Illustrations of useful Plants employed in Medicine, &c. By M. A. Burnett. Nos. I, II, III, and IV. 4to. London, 1839-40. Each number contains two coloured plates, with letterpress descriptions from the unpublished MSS. of the late Professor G. T. Burnett, and the price of each is only 1s.

Miss Burnett is the sister of the late professor of botany in King's College; and of the usefulness of this work, as well as of the fidelity of its execution, we have the authority of Dr. Sigmond, in the following extract from a letter printed on the wrapper of No. II. :—

“ They [the plates of the tobacco plant and the blue passion-flower] are executed with great fidelity, and accurately coloured. Such a work must prove unusually interesting, from its furnishing portions of the unpublished manuscripts of my learned friend, the late Professor Burnett. — *George G. Sigmond, M.D. August 31. 1839.*”

Would that any thing that we could say might promote the sale of this publication; not only to put us in possession of the unpublished manuscripts of Professor Burnett, for whose memory we have the very highest respect, but for the sake of his amiable and accomplished orphan sister! Such a work from such an authoress merits the especial patronage of the families of professors and medical men, and also of every lady of wealth and rank who wishes to encourage talent and promote virtue.

Kew and its Gardens. By Frederick Sheer, Esq. Post 8vo, pp. 69. London, 1840.

Besides the description indicated in the titlepage, some notice is taken in the preface of the alleged intention of government to give up the Royal Botanic Gardens at Kew; and an appendix contains a petition to the Lords of the Treasury from the Richmond Literary and Scientific Institution, praying that the botanic gardens at Kew may not be abolished. Similar petitions, it is stated, were agreed on at the Richmond and Brentford Mechanics' Institutions.

Della Origine ed Anzianità dell' Orto Botanico di Padova, &c. On the Origin and Antiquity of the Botanic Garden of Padua. By Professor Visiano, Prefect of that Garden. 8vo, pp. 43. Venice, 1839.

The origin of the garden is traced to 1533, and an account of it is brought down to 1787.

The American Flower-Garden Directory, &c., &c. By Robert Buist, Nurseryman and Florist, Philadelphia. 8vo, pp. 380. Philadelphia, 1839.

This differs from most of the American works on gardening, in being an original composition from beginning to end. It is most judiciously adapted to the country in which it is published; and the author is one of the best cultivators in the United States. There is no American work that we know of at all to be compared with it in point of usefulness. We owe the author an

apology for not having sooner acknowledged the receipt of the copy he kindly sent us above a year ago.

The Rose Amateur's Guide, &c. By T. Rivers, jun. Second edition, greatly enlarged. Small 8vo, pp. 185. London, 1840.

The present is a greatly improved edition of a work which we have commended in our volume for 1838, p. 94. It is here in a more portable form, with various additions, and with a valuable "Abridged List of Roses, adapted for Amateurs possessing small Gardens, or for those beginning to form a Collection; selected so as to give the leading Variations of Colour." We cannot sufficiently commend Mr. Rivers for having given this abridged list; for the long columns of names in the catalogues of the rose nurseries, both French and English, are quite appalling. It appears from Mr. Rivers's abridged list that the essence of all the cultivated roses may be included in twenty-five sections, including 185 sorts. Allowing 2 square feet for each sort, a bed 40 ft. by 10 ft. would contain a representative system of all the roses in cultivation.

Descrizione dei Funghi Mangerecci più comuni dell' Italia, e de' Velenosi che possono co' medesimi confondersi, &c. Description of the eatable Fungi less common in Italy, and of the poisonous Sorts which are most liable to be confounded with them. By Carlo Vittadini, M.D. 4to, pp. 364., with 44 coloured plates. Milan, 1835.

To those who study the fungi this must be a very valuable work, and we believe that there are but few copies of it in England. The plates are very beautifully engraved on copper from drawings by Vittadini from nature, and they are most carefully coloured. It would be an interesting and useful task, for a gardening amateur resident in Italy, to try how far all the edible sorts enumerated in Vittadini's book might be cultivated in a garden; and afterwards their spaw might be sent to England for the same trials here.

Verhandlungen der K. K. Landwirthschafts-Gesellschaft in Wien, &c. Transactions of the Imperial and Royal Agricultural Society of Vienna, &c. Vol. VIII. Part II. 8vo, pp. 146. Vienna, 1840.

An article on the different modes and times of felling timber, and one on the vineyards of Austria, may be interesting to some of our readers.

Transactions of the Society of Arts, Manufactures, and Commerce. Vol. LII. Part II. 8vo, pp. 173. to 409., one 8vo and three folding plates. London, 1839.

The agricultural articles in this part are, On Improvements in the Culture of the Cambridge Fens, and on the Cultivation of Potatoes from Seed. Draining with a steam-engine, and improving the outfall of rivers in the manner alluded to in our volume for 1839, p. 563., have enabled the occupiers of fen lands to avail themselves of the valuable strata of clay and marl which are now accessible at a very short depth from the surface, and by which a new and most advantageous system of farming has been introduced. The practice of spreading clay and marl upon the surface of fen, moss, or peat bog has long been in use in Scotland, as shown in Steel's *History of Peat Moss*; and it is now practised generally on the great Bedford Level in Cambridgeshire, which contains upwards of 300,000 acres. The quantity laid on is about 200 cubic yards per acre; it is thrown out of the pits or subsoil by hand with the spade, and the total expense is from 50s. to 70s. per acre.

W. Buchanan, Esq., of Chalk Lodge, near Cheshunt, sowed Potato Seeds in April, 1836, the tubers produced by which were taken up in October of the same year, and replanted the following spring. In the autumn of the second year an excellent crop was obtained of tubers of very good size; thus showing, that, by means of transplanting the seedlings and giving them abundance of room in good light rich soil, a tolerable crop may be obtained the first year, and a very good crop the second.

An Analysis of the East Window of Carlisle Cathedral, by Mr. Billings, is

very interesting, and shows what profound masters the Gothic architects were, in all that relates to construction.

Report on A. M. Perkins's Patent Steam Boiler. By Josiah Parkes, Esq., Civil Engineer. 4to, pp. 19, one folding plate. London, 1840.

Mr. Perkins's improvements being more adapted for engineering purposes than for heating hot-houses, we have only to record the title of the work, as having been sent to us.

Twenty Years' Experience in Australia, &c. Small 8vo, pp. 115, third edition, 15,000. London, 1840. Price 6d.

The object of this very cheap tract, the author of which is said to be Dr. Udney, is to "demonstrate the extraordinary advantages of emigration to New South Wales, alike to men of capital and the labouring classes." It also contains "facts and observations, showing the present circumstances and prospects of New Zealand," to which colony the author of this tract does not seem favourable.

MISCELLANEOUS INTELLIGENCE.

ART. I. *General Notices.*

GLAZING with Lead instead of Putty. (p. 275.)—In reply to your note respecting the paragraph on glazing with lead instead of putty, I must premise that "the sides of the sash bars" should have been "the side bars of the sashes." Of course by lead is meant lead lap. The inconveniences attendant on glazing with putty are many; and I need only mention the parting of the putty from the wood, even where the roof is kept well painted, and especially those arising from the replacing of broken panes. When the last-mentioned work is to be done, the woodwork is sure to be damaged in cutting out the old putty; and, what is a far greater mischief, the corners of the new pane are chipped off by the glazier, because, unless the glass is of precisely the same thickness, he cannot otherwise insert it underneath the pane above. A constant drip is thus secured, and you know what must be the consequences. With lead lap it is otherwise; the lead has merely to be raised, the new pane inserted, and a little of the soft putty or white lead rubbed into the sides, and the work is done. This plan of glazing I have never carried into effect, except in small pieces as specimens of its practicability; but, shortly after I first contrived it, I saw your notice in your volume for 1836 (p. 313.) of Barrett's Nursery at Wakefield, where you mention that a hot-house was glazed in some such manner. I met with Barrett about a year afterwards, and he told me he had not a single "drip" in the house. Mr. Beaton wrote me that such glazing is done at Birmingham, and I presume there will be no difficulty in getting this kind of work executed there. I do not, however, see any necessity for employing any one but a common glazier who has been accustomed to work what, I believe, is called "church work." My plan would be this. To glaze each row of the slide or sash by itself, putting in the panes in the usual way, to rub in the soft putty used in such work, and carefully close the lead upon the glass, especially where the panes overlap. When the required number of rows to make a sash or slide are finished, they ought to stand a week or two to harden the putty. The sash itself should be precisely like the ordinary one where putty is used, except that the portion or strip of wood which separates the rows of panes must be cut entirely away, or rather never be formed; and, instead of the usual rebate at the sides and top of the sash, a groove should be made (say quarter of an inch deep) to admit the outside lead lap. The whole must next be well painted. Then take a row of panes, open the outside lap of one of its sides, and insert the closed lap of the row

which is to join it, rub in a little of the soft putty, close it down and apply a few drops of solder here and there to keep them together. Next open the outside lap of the second row and insert the edge of the third row in the same manner, and so on, until the size of the sash is complete. When the sheet of glass, so to speak, is finished, slide it into the grooves of the outside side bars or frame of the sash, and fill up any open space with common putty. A few small brass or copper nails, with good heads, should be driven through the double lead-lap between each row of panes, at intervals of 6 or 9 inches, into the wooden bars below, to fasten the lead and glass to the frame; the work is then complete. You will now perceive that the only woodwork of the sashes exposed to the weather is the sides or frame; and, I think, you will agree with me that that is no little advantage. The woodwork must be very accurately made, otherwise the joining of the rows of glass will not correspond with the bars, and of course there will be nothing to drive the nails into. — *Amicus. May 6. 1840.*

Temperature.—The following interesting extract is from an article by Col. Hall, of Quito, in Dr. Hooker's *Journal of Botany*:—"The mean temperature of the neighbourhood of Quito may be reckoned about 56° ; that of the city itself is about 57° . The temperature of the southern basin is rather higher, and may be estimated at 60° . Every difference of elevation produces, of course, a corresponding variation of temperature. The mean of the Paramos may be reckoned at 38° ; and when we reach the limits of perpetual snow, at 32° . There is a circumstance worthy of notice, with regard to the temperature of elevated tropical regions, because it has a powerful influence both on animal and vegetable life; that is, the uniformity of the yearly temperature, so different from our European seasons. Thus, as Humboldt observes (*De Distributione Geographica Plantarum*, p. 152.), the mean temperature of Quito is nearly the same with that of the South of France; yet a variety of European fruits, such as peaches, nectarines, grapes, figs, &c., which ripen well with even an English summer, never reach perfection in Quito, where the daily range of the thermometer throughout the year is from 48° to 65° . The plants of the Andes will, for the same reason, be with more difficulty naturalised, and more readily degenerate, in Europe, than those of the Alps or of northern latitudes, when transported to warmer climates; since both in the Alps and in Lapland there is an alternation of summer and winter, differing only in length and intensity from those of France or England; while the plants of the Andes are rarely exposed to a variation of above 17° throughout the year. They thus acquire, like the inhabitants, a constitution ill adapted to support great changes. I have never been able to cultivate the plants of the Paramos, even in Quito: the seeds refuse to germinate, or the plants either perish before taking root, or preserve a brief and languishing existence. No doubt other circumstances, such as atmospherical pressure and the action of light, cooperate, as Humboldt observes, with the effect of temperature; but these circumstances increase the difficulty of vegetable emigration. Another peculiarity of the elevated tropical regions is the great heat of the sun's rays, as compared with the shade. I have seen a thermometer placed on the grass at Quito rise to 120° , which is equal to its utmost range at the level of the sea; while in the shade its extreme range is 60° to 66° in the high lands, and 80° to 88° on the coast. It is for this reason that the heat seems more oppressive in Quito than in Guayaquil, there being frequently in the former a difference of more than 60° between the two sides of a street or wall; and these daily inequalities contrast more strongly with the annual uniformity of temperature already indicated, and still farther complicate the peculiarities of Andean vegetation. I have alluded to reflected heat, because it is that to which animal and vegetable life are subjected, and, perhaps, the only modification of the sun's rays which can be accurately examined. It seems more easy to naturalise the vegetable productions of Europe in the regions of the Andes than *vice versâ*. European flowers adorn the gardens, and European vegetables supply the tables of Quito, as the Cerealia is one of the few benefits conferred by the

Spaniards on the New World. The indigenes appear to have used only maize, the *Chenopodium Quinoa*, the potato, and the *Oxalis tuberosa*, or oka. Barley-meal constitutes, at present, the chief article of their diet; for bread, though cheap, scarcely falls within their scanty resources. Oats and rye are, as yet, unknown, though well adapted to many of the poorer soils, especially the sandy tracts round Ambato and Rio Bamba. The same cause which prevents the perfection of European fruit, limits the number of those of native growth. About the elevation of Quito we find none wild but the capuli, a species of blackberry; and, on sandy soils, the tuna. Currants, gooseberries, and raspberries seem adapted to the climate, but have not yet been introduced. Strawberries are abundant; but they are probably natives of Chili. Pears and apples are plentiful, but small and ill-flavoured. The celebrated peaches of Ambato remind the European traveller less of the likeness than of the difference. Pine-apples, cherimoyas, oranges, limes, aguacatis (*Laurus Pérsica*), granadilla (*Passiflora*?), and other tropical fruits, are brought from the adjacent valleys or calientes, but, it may be supposed, little improved by the journey. The idea of perpetual spring is pleasing to the imagination; but the reality is purchased in the Andes by the want of those glowing forms and colours which nature sheds over tropical climates, while the monotony of earth and sky, scarcely observable by the traveller, would be gladly exchanged by the less fortunate resident for the varied interest of European seasons." (*Hooker's Journal of Botany.*)

Effect of Light which has passed through coloured Glass on Plants.—I planted in a box some curled cress seed, and so arranged bottles of carmine fluid, chromate of potassa, acetate of copper, and the ammonia sulphate, that all but a small space of the earth was exposed to light, which had permeated three fourths of an inch of these media. For some days the only apparent difference was, that the earth continued damp under the green and blue fluids, whereas it rapidly dried under the red and yellow. The plumula burst the cuticle in the blue and green lights, before any change was evident in the other parts. After ten days, under the blue fluid there was a crop of cress, of as bright a green as any which grew in full light, and far more abundant. The crop was scanty under the green fluid, and of a pale unhealthy colour. Under the yellow solution, but two or three plants appeared, yet they were less pale than those which had grown in green light. Beneath the red bottle the number of plants which grew was also small, although rather more than in the spot the yellow covered. They, too, were of an unhealthy colour. I now reversed the order of the bottles, fixing the red in the place of the blue, and the yellow in that of the green. After a few days' exposure, the healthy cress appeared blighted, while a few more unhealthy plants began to show themselves, from the influence of the blue rays, in the spot originally subjected to the red. It is evident from this that the red and yellow rays not merely retard germination, but positively destroy the vital principle in the seed. Prolonged exposure uncovered, with genial warmth, free air, and indeed all that can induce growth, fails to revive the blighted vegetation. I have repeated the experiment many times, varying the fluids, but the results have been the same. At this time, I have the above facts strikingly exemplified where the space covered by the bichromate of potassa is without a plant. These results merit the attention of those who are engaged in the study of vegetable economy. Do they not point at a process by which the productions of climes more redolent of light than ours may be brought in this island to their native perfection? Dr. Draper's "experiments," *Philosophical Magazine*, Feb. 1840, appear at variance with mine. Under the influence of a nearly tropical sun permeating half an inch of solution of the bichromate of potassa, cress grew of a green colour, whilst it took five days to give a sensitive paper a faint yellow green colour. From this, Professor Draper argues the existence of two classes of rays, a different class being necessary to produce the green colouring of vegetable foliage from that which darkens chloride of silver. With submission to one whose facilities for such enquiries are so much greater than my

own, I would suggest a repetition of the experiments with some of the recently discovered photographic preparations. The fact of cress and pea plants growing green, under the influence of such powerful light as penetrated Professor Draper's yellow media, will not appear at all surprising when we examine the rays which pass through such fluids.

The above curious and interesting experiments form part of a paper by Mr. Robert Hunt "On Light which has permeated coloured Media, and on the chemical Action of the Solar Spectrum," published in the April Number of the *Philosophical Magazine*. — *J. B. W. May, 1840.*

A Hand-Plough for stirring the Soil between Carrots, has lately been invented in Belgium, and sent over to this country. For moderately light soils it promises to be a valuable implement, being applicable to various small plants grown in rows in gardens, such as onions, parsneps, turnips, &c. The implement may be had at Weir's manufactory, Oxford Street. — *Cond.*

Preserving Wood by steeping it previously to use in a cold-water solution of lime has lately attracted a good deal of attention; but the process was invented and used by Sir Charles G. S. Mentenath, at Closeburn, in Dumfriesshire, above thirty years ago, as noticed in our *Encyclopædia of Cottage Architecture*, and in the *Farmer's Magazine*. — *Cond.*

Sunk Water-holders. — I have been trying the pots invented by my brother Henry for watering plants, and find the plan admirable. As you have given a full and complete description of it in the volume for 1839, p. 525., I need not repeat it here, my main object at present being to show that it may be resorted to by any one who may have by him a few stone or glass quart bottles, for I have used both. In the side and near the bottom of the bottle I cause two small holes to be made, the smaller the better; the bottle is then buried to the neck near the root of the plant or flower which requires watering; it is then filled and *corked down*. The exclusion of the atmospheric pressure, except through the small orifices under ground, causes a very gradual, almost drop by drop, exudation of the water from the bottle; and this slow delivery of moisture I consider an improvement upon the more powerful jet or jets which must necessarily issue from any open vessel. My brother has three openings in the side of his water-pots, I think he has one too many; for if the water can make its way out at all, the slower the better, and it must run slower from two than from three holes. Mine are made, one as near the bottom of the bottle as possible, the other about 2 in. or so above it. Another advantage of corking the vessel is, that insects and dirt are thereby excluded. It strikes me, that if Dr. Lindley had seen this plan it would have removed some of his objections to artificial watering; objections which, I entirely agree with him, are most rational and well founded. "This operation," he observes, "is usually performed in hot dry weather, and must necessarily be very limited in its effects; it can have little, if any, influence upon the atmosphere: then the parched air robs the leaves rapidly of their moisture, so long as the latter is abundant; the roots are suddenly and violently excited, and after a short time the exciting cause is suddenly withdrawn, by the momentary supply of water being cut off by evaporation and by filtration through the bibulous substances of which soil usually consists. Moreover, in stiff soils, the dashing of water upon the surface has, after a little while, the effect of 'puddling' the ground, and rendering it impervious, so that the descent of water to the roots is impeded, whether it is communicated artificially or by the fall of rain. It is therefore doubtful whether artificial watering of plants in the open air is advantageous, unless in particular cases; and, most assuredly, if it is done at all, it ought to be much more copious than is usual." (*Theory of Hort.* p. 126.) — *Samuel Taylor. Stoke Ferry, April 18. 1840.*

Myatt's Pine Strawberry, commonly thought to be "obstinately sterile, and therefore not worth cultivating," has been found so in Ireland by the Hon. Baron Foster, till he "tried it in very rotten cow-dung, turned and decomposed through four or five successive years, without the mixture of any other substance; and, having planted the strawberry in this, under the shelter of a south

wall," Baron Foster "obtained as large a crop of both fruit and runners as from any other kind." (*Ibid.*)

Raising Coniferous Plants from Seed. — A paper was read from Mr. G. Gordon, the foreman of the arboretum in the Horticultural Society's Garden, at the Society's meeting, Dec. 3. 1839; by which it appears "that the principal points to be attended to are to sow the seeds in pure loam, without any mixture of peat, and with as little sand as possible; to take care that the loam is nearly dry until the seeds have vegetated, and then to administer water only in very small quantities; to stimulate germination by the application of bottom heat, which is, however, to be abstracted as soon as the plants make their appearance above ground." (*Proceedings of the Hort. Soc. of London*, vol. i. p. 117.)

The Genus Vaccinium contains so many species that bear excellent edible fruit, that I am surprised these are not more cultivated than they are as fruit shrubs. There are many gardens in the North and West of Scotland, and in the mountainous parts of England, and almost everywhere in Ireland, where peat can be procured at little expense; and in all such gardens most species of *Vaccinium* would luxuriate, and produce fruit in abundance. The fruit is excellent, eaten with cream, or made into tarts or jellies. — *S. M. Glasgow*, April, 1840.

The Triumphal Arch. — The invention of the triumphal arch belongs to the Romans, and it is one of their very few contributions to the fine arts, for the Greeks were strangers to it. I find nothing in it to admire. It is precisely an ornamental gate, but, standing as it always does in an open space, it is an object without meaning, a gate without an enclosure, a door without a house. (*Scotsman*, Feb. 12. 1840.)

We entirely concur in this opinion of the editor of the *Scotsman*, having been forcibly struck with the same idea when looking at the triumphal arches in Petersburg and Moscow, some years before we visited Italy. What can be more absurd than the triumphal arch at Buckingham Palace, except that in such a climate as London it is cased with polished marble! A casing of Welsh slate would have been appropriate to the smoky valley at the bottom of which this mass of deformity obtrudes itself. — *Cond.*

ART. II. Foreign Notices.

GREECE.

THE Grecian Cottage of the present Day. — A cottage occupied by the peasantry in this part of the country (Lycia), will show that scale alone is wanting to make it the temple of the former inhabitants; the tombs cut in the rocks in successive ages are also precisely similar in architectural design. (*Journal in Asia Minor*, p. 234.)

A Group of Grecian Plants suitable for placing around a Grecian statue or other classical ornament in a flower-garden may consist of the following species, all of which were found in Pamphylia, near the base of the Taurian Mountains, by Mr. Fellows: *Styrax officinale*, *Cistus Fumana*, *Sálvia Horminum*, *Anagállis cærúlea*, *Fumária capreolàta*, *Gladiolus communis*, *Muscàri comòsum* and *M. botryòides*, *Scilla marítima*, and *Ornithógalum umbellàtum*. (*Journal in Asia Minor*, p. 186.) A suitable sculpture ornament for such a group would be one of the water jars figured in Mr. Fellows's work, in p. 259., used in the same part of Asia Minor for supplying water to the weary traveller, in the manner of the springs and cisterns sometimes placed by benevolent persons by the sides of the public roads in Britain. These water jars "are made of red clay, and are in form precisely like the terra-cotta vases of the ancient Greeks. As they stand but insecurely, they are seen tied to the trunks

of trees by the way side, and kept constantly filled for the use of the traveller. To secure a great supply of water, in parts of the country remote from natural springs or aqueducts, is a religious care, for the ablutions before prayer. The replenishing of these jars is usually the care of the women, who may be seen carrying them upon their backs, slung by cords in the manner represented in the sketch," above referred to. (*Journal in Asia Minor*, p. 258.) The vase and the figure may afford a good hint for Mr. Austen, and the whole may serve to furnish ideas for a classical group in a flower-garden.—*Cond.*

ITALY.

Monza, March 19. 1840.—I could not resist, though extremely busy at present, glancing a little at some of the works which you have sent me, particularly the *Suburban Gardener*, which I find most interesting and useful, as well for gardeners as for amateurs who wish to attend to gardening for its own sake. I regret I have not sufficient time at my disposal to benefit my countrymen by giving them a translation of this excellent work, being convinced that it would tend in no small degree to the developement of the love of horticulture. I do not, however, entirely give up the thought, but as soon as the many demands on my attention consequent on my employment will permit, I will try whether I am capable of entering into the spirit of the author, without which it would be time and labour thrown away.

I was truly affected and surprised at the politeness of N. W. G., who is so kind as to offer me seeds of the *Nelúmbium speciosum* var. *rúbrum*. I beg of you to tell him how sensible I am of his generosity, and I shall consider myself fortunate if he will furnish me with an opportunity of proving my gratitude.

In addition to what I have already told you about the pinetum of the Baron Alessandro Zanoli (p. 98.), I now send you a notice of the new species of pines which he has introduced this year: *Abies Clanbrasiliana* stricta, *A. cephalónica*, *A. excélsa* fóliis variegátis, *A. exc. monstrósa*, *A. exc. pygmæa*, *A. exc. tenuifólia*; *Dámmará* austrális; *Làrix americana* rùbra, *L. europæa* sibírica; *Píceá* pectinàta tortuósa; *Pinus* Cólterí, *P. Chýlla* excélsa?, *P. C. serótina*, *P. C. microcárpa*; *P. Pináster* fol. variegátis, *P. ponderósa*, *P. pátula*, *P. Cémbrá* sibírica, *P. Stróbus* pygmæa.

I told you in my last letter (p. 99.), that the celebrated Marquis Cosimo Ridolphi, of Florence, had offered for sale hundreds of pounds' weight of the tubers of the twining batata (*Ipomœa Batatas*). I now hear from the marquis that he has succeeded in preserving the tubers perfectly well during the winter, by merely keeping them in a cellar where a uniform temperature is maintained: but a slight degree of dampness had, on the 30th of January, at which time this information was communicated to me, caused spontaneous germination, as is the case with the common potato (*Solànum tuberòsum*). Thus every difficulty is overcome, either as to cultivation or preservation, the latter of which was the greater, and that alone, as we may say, which made the cultivation of it to be abandoned. Thus has the Marquis Ridolphi succeeded in naturalising perfectly a plant of so much importance and advantage.

A friend of mine has promised to introduce me to a person who is soon to set out for London. I shall take the opportunity of sending you a treatise on the edible fungi of Lombardy.

If I were not afraid of appearing too greedy, I would beg of you to procure me a single seed of *Nelúmbium álbum*. [We should be greatly obliged to any correspondent who will send us such a seed to forward to our much esteemed friend.]

Monza, Aug. 20. 1836.—In continuation of what I have already sent you (*Vol. for 1836*, p. 445.), I will now speak of the villas Mallerio, Silva, Litta, and the garden of Dr. Sacco.

The Villa Mallerio at Gernetto is in Brianza, in a country where nature and art seem to have united the useful with the agreeable. Its favourable soil and

delightful climate make it produce excellent corn; and its vines, in point of quality, can vie with any in France. The Milanese gentlemen, allured by the charms of the place, have congregated there; by which means the country has become interspersed with the most delightful rural retreats. Amongst these gentlemen the Cavalier Gargantini is the most distinguished. The buildings which he has constructed on his estate are in a very elegant style of architecture, and contain every convenience required by an agriculturist. I intend some day to give you an account of the agriculture in Brianza, and in that case I will give you designs of some of the buildings on the estates mentioned; because it appears to me that they merit a place in the supplement which you propose for your very useful *Architectural Encyclopædia*. Gernetto is situated at the distance of only two leagues north from Monza, and five from Milan, on an eminence; at the bottom of which, on the west, flows the Lambro; and from the north to the east is seen the most delightful romantic valley. The proprietor, Count Giacomo Mallerio, knowing the advantages of the situation, so improved it as to produce a most delightful retreat. He has formed the valley into a park, which occupies a superficial space of 500 Milanese *pestichi*. This park is a true English garden. Man has only to adorn it with buildings (*monumenti*), and to form suitable paths, as the heights, valleys, brooks, &c., are formed by the great master-hand of nature. The slopes exposed to the west are laid out in terrace-gardens (*scaglioni*), called the Genoese style here. I cannot give you an idea of the view I enjoyed from the top of the hill, with the majestic windings of the river Lambro below, varied by the beautiful ancient trees which flourish on its banks, and by the flocks and herds which pasture in the contiguous fields and on the opposite hills; the chain of the Alps towering on the west; and the flat-lying Lombardy on the south, extending as if to the Apennines.

I mentioned in a return paper last year that a *Melia Azederach* grew in the open air in this garden 40 ft. high, and the circumference of the trunk 48 in.; but this year it has been very much injured, on account of the severity of last winter. I should not, however, say that the winter was severe, as the temperature at a minimum was at 9° 8' of Reaumur; whereas, in other winters, the temperature is sometimes so low as 15°. In 1829–30, for two nights only, it was at 12°; and for four or five days it was at 10°, when it returned to 4° or 5°, with a sky continually clear: but this year, on the contrary, the temperature was at 9° for several days, with an atmosphere always loaded with vapour; and for ten or twelve days a single ray of the sun did not appear, and the nights were clear; and, on this account, the white frost remained attached to the trees as if it had snowed, and did much damage to many plants which, in former winters, stood the open air without the least injury, such as *Pittosporum Tobira*, *Amýgdalus orientális*, &c. The *Magnòlia grandiflora* lost almost all its leaves, and several of the weakest plants died. I observed here three camellias, with flowers of a simple red colour, standing the open air in the most luxuriant state of vegetation, and measuring 10 ft. in height. They are planted in a situation which is sheltered from the north and east winds, the latter of which is particularly hurtful to our vegetation. The excellent gardener, Signor Antonio Mavari, assured me that they had no other protection than a cap of straw, and a few dried leaves at the bottom of the stem. The Count Mallerio was one of the first who introduced the camellia and the *Pæonia Moítan* into Italy; so that he has now camellias 12 ft. high, and the diameter of the trunk 5¼ in. I admired a beautiful collection of pelargoniums here, amongst which there were several species of recent introduction; also beautiful specimens of *Eucalyptus robústa*, *resinífera*, and *paniculàta*, *Clèthra arborea*, and *Rhododéndron arboreum*. Besides the orangery, which is built in a most beautiful style of architecture, there is a stove for pine-apples, where they are cultivated with great care.

Villa Silva at Cinisello. Cinisello is a village two leagues and a half north from Milan, and one and a quarter south-west from Monza. This villa is the summer residence of Count Hercules Silva, author of the work entitled *Dell'*

Arte de' Giardini Inglesi ("On the Art of English Gardening").* The garden of this villa measures 100 superficial Milanese *pestichi*. It was laid out in 1797; and it may easily be supposed that, from the extent of ground well grouped with trees, &c., it may serve as a model to landscape-gardeners; but the absence of water is a fault. There are busts scattered here and there, which recall to the mind the recollection of great men dear to their country, temples, thatched cottages, &c., all so well arranged as to give a good idea of the taste and profound knowledge of the proprietor, who laid out and arranged the whole. I observed the following plants standing the open air: *Pistacia officinarum*, *Magnolia* ten species, *Abies canadensis*, *Lagerstrœmia indica*, *Pinus nepalensis* (*longifolia*), *Camellia japonica*, *Araucaria imbricata*, and *Altingia excelsa*; the four last are protected in winter.

Villa Litta, at Lainate; about three leagues and a half north from Milan, and about the same distance west from Monza. This garden is laid out in the French style; but, latterly, the directors, Linneo and Auroneo Tagliabre, brothers (the former is author of various important articles on botany and horticulture in different scientific journals), have reduced part of the garden to the English style. This villa is celebrated for its grottoes; and there are fountains and water-works, which, from their great variety, must have cost an immense sum. The floors and great part of the walls of these grottoes are inlaid with mosaic work, and small flints of various colours, ingeniously put together, and arranged with taste; the other parts of the walls are covered with a calcareous tuffa, all of which gives a good idea of a real grotto. In some of the rooms of these grottoes there are seen various objects of mineralogy and conchology, tables inlaid with hard (*dure*) stones, *lumachetti*, and porphyry. There are small statues in bronze, representing Mars unarmed, and a Venus and a Magdalene in marble, the workmanship of the celebrated Professor Pompeo Marchesi. The northern *façade* of this building is in good taste; the style appears to be *bramantesco*, and is ornamented with marble statues, amongst which there are two by Michael Angelo, representing twilight. The conservatories are filled with beautiful plants; and the luxuriance of their growth speaks for the intelligence and care of those who have the management of them. I observed the following plants among them: *Lagerstrœmia regina*, *Eugenia nervosa*, *Caryota urens* and *Onites*, *Pandanus odoratissimus* and *sylvestris*, *Coccoloba pubescens* and *emarginata*, *Cytisus scariolus*, *Allamanda verticillata*, *Banksia latifolia* and *Lamberti*, *Guilandina Nuga*, *Kleinhöfia hospita*, *Pinckneya pubens*, *Pöthos digitata*, *Robèrgia Pænea*, *Terminalia angustifolia*, *Theophrasta americana*, *Zamia pungens*, *Calamus Rötang*, *Zizyphus nepalensis*; *Bromelia Ananas*, *barbadensis*, *coccinea*, *jamaicensis*, and *mala-bàrica*, *Montserrat*, *Providenza*, *rotunda*, *rùbra*, and *antiqua*; *Tillandsia dianthoides* (the *Amàlia aerisíncola*, see *Gard. Mag.* vol. iii. p. 209.), &c. The *Littæa geminiflora* flowered for the first time in Italy in this garden, in the autumn of 1815. Amongst the *Agrumi* I observed the *Citrus nobilis*, *madariensis*, and *sinensis*. The kitchen-garden is well stocked, and a part of it is dedicated to the cultivation of three varieties of the *Convólulus Batatas* (*Ipomœa Batatas*), viz. the red, the white, and the yellow; they grow luxuriantly. We have never seen this vegetable in flower, even in warm summers; some of the tubers, when planted in the natural soil (*terreno normale*), and sufficiently watered in dry weather, attain the weight of 49 oz. The red variety is considered the most delicate by us, but it does not attain the large size of the yellow and the white.

The Garden of Cavaliere Dr. Luigi Sacco in Milan.—After speaking of the most celebrated gardens in the circuit of Milan, I will now treat of those that adorn that city. There are several horticultural commercial establishments in Milan, and also several establishments for horticulture

* In your *Encyclopædia of Gardening* you say that the author of *Arte de' Giardini Inglesi* is Sigismondo Silva. [See the article on the garden literature of Italy in the current volume, p. 71.]

belonging to individuals who are devoted to the worship of Flora, and make themselves agreeable to her by cultivating plants, and endeavouring to add new glory to her crown by means of seeds. Although but few varieties have been obtained this year in the catalogue of roses, dahlias, camellias, pelargoniums, &c., their exertions remain unabated. Amongst these amateurs is the celebrated Cavaliere Dr. Luigi Sacco, physician and surgeon, to whom Italy is indebted for the discovery of the vaccine matter indigenous to the cows of Lombardy. We owe a great many of the varieties of the rose to this indefatigable naturalist; such as the Maria Luigia, Bella Aurora, Impératrice, Carolina, Coloural, Bella Archinto, *índica foliácea*, Hardy, *odoratíssima*, *violácea*, *microphýlla rósea*, *m. coccínea*, *m. álba*, which three are frequently called Maria Leonida álba, *coccínea rósea*, and *Noisettiána campanuláta*. His chief attention is directed to two genera of plants, the camellia and the rose. He was also one of the first who introduced the camellia into Italy. He undertook a journey to Paris in 1810, and brought back with him the *Caméllia japónica*, álba plèna, *variegata plèna*, *rùbra símplex*, and *rùbra máxima*; but as he and other horticulturists did not know the method of cultivating these shrubs, and as they had not the soil suitable for them, for the space of ten or fifteen years you could not say that one of the camellias looked healthy; and, to prove that they did not spare expense to attain their object, this very Dr. Sacco sent to Paris for the same sort of soil in which he saw them grow so well; but, by continual and indefatigable exertions, they at last succeeded in finding the soil adapted to this genus of plants. That from the banks of the Lakes of Como and Maggiore is the best. Some mix this vegetable soil with a proportion of a half or third of the chestnut soil; that is, the soil produced from the leaves and small branches of the chestnut (*Castànea véscá*). You may easily suppose that all the amateurs and collectors of camellias reckon the prosperity of their plants from the date of the discovery of this soil; and the vigour they acquired from it was such, that they have fructified, an advantage not always obtained. Dr. Sacco possesses no fewer than 8000 camellias, and amongst them there are more than seventy new varieties obtained by him, amongst which the following may be mentioned as remarkable for the beauty of their flowers (as I was enabled to judge by looking over the book in which the most remarkable are painted from time to time): — *Coronàta*, *fasciculáta*, *venòsa*, *annuláta*, *Tirzi*, *Élena*, *Fanny*, *anemoneflóra*, *admirábile*, *althææflóra*, *mínima*, *paradisáica*, *odoráta Hyacínthi*, *odoráta violácea tubiflóra*, *Maria Elisabetta*, *conchiflóra*, *Raniesi*, &c. A very great many of the camellias are planted in the open air; but, when the cold weather sets in, the garden is covered with glass, which occupies a space of 100 ft. long and 70 ft. broad. In winter this small garden is warmed in the old way; that is, with wood fires; which article being expensive on account of its scarcity, it becomes of consequence. The heat is conveyed in brick flues under the paths, which is found to be the best way of distributing it. Dr. Sacco, when I visited his garden (June 22. 1836), told me the expectations he had of making improvements in his silkworms, so as to be able to prove that the *caleine* is a contagious disease. This learned naturalist promised to give me the results of his experiments; and as soon as I receive them I will forward them to you.

In speaking of the silkworms, you must already know, by the scientific journals, that there are a great many persons here in favour of the mulberry of the Philippine Islands (*Morus cuculláta* or *multicaúlis*) for rearing them, and also a great many opposed to it. I will speak of it *sine odio vel amore*, as I cannot be suspected of spirit of party, not having any interest in the subject, either in a commercial point of view, or otherwise. I only bring the subject before you, as it forms a branch of our agriculture. From some experiments made by one of my brothers, he has succeeded in persuading me that the mulberry of the Philippine Islands is far superior to the common mulberry (*Morus álba*).

1st. Because it grows with a rapidity perhaps threefold that of the common one, and thrives extremely well in any soil, and in various situations,

and on the elevated part of ridges in fields, in rows with the common willow. As it does not require grafting, the leaves may be taken off with impunity the following year after it is planted; and, for this reason, it is more advantageous than the common mulberry for forming groves or hedges round farms, because the common one is always grafted the second year after planting, and cannot be deprived of its leaves for five years afterwards.

2dly. Because it is easily propagated by truncheons (talea) from spring to the end of July; and these stocks may, without fear, be deprived of their leaves the following year. Dr. Lomani, well informed in agricultural science, and principal editor of our *Agricultural Journal*, says that, after the leaves have been taken off to feed the silkworms, if the stripped shoots be planted, although in a place exposed to the sun and without shelter, they will readily vegetate, both above and below the soil. My brother Luigi, your former correspondent, wrote to me last June: — “I have discovered a very rapid method of propagating the mulberry of the Philippines. After taking off the leaves to feed the silkworms, cut out the buds from the shoot and plant them; and as many plants will grow as you have planted buds.” This supports the theory of Petit Thouars; which is, that the tissue of the vital point of the foliaceous bud is capable of elongating itself, and forming a stem above, and a root below. In this way shoots may be obtained of this mulberry, which are much more profitable than those proposed by Signor Bassi of Lodi, with the *Morus Morettiana*.

3dly. Because it has an exceedingly large leaf, so that it produces, in weight, a result almost double that of a leaf obtained from the common one; and, compared with that, it has been found more nutritious; so that if 1000 lb. weight of the common one is required for every ounce of eggs, it will be found that 800 lb. weight of the leaves of the mulberry of the Philippines will be found sufficient; and although the leaves are not so twisted up (incartata) as those of the common mulberry, they can be collected, and, like them, put in bags, and sent to a distance.

4thly. Because the leaves come out fifteen or twenty days before those of the common mulberry; and, therefore, the hatching of the eggs may be anticipated, and they will be more than usually abundant, because they have been produced in a cool temperature; and should an unexpected hoar frost happen, which destroys the first leaves, it is already known that the new mulberry appears again covered with leaves in a much shorter time than the old; and as it has the advantage of continuing to grow to the middle of November, and the common one ceases to do so towards the latter end of September, it may be stripped of its leaves with impunity at every period, so that a second brood of silkworms can be obtained in August and part of September; and the celebrated Dr. Lomani is also of this opinion.

But the greatest advantage resulting from the worms feeding constantly on the new mulberry is that they produce cocoons of so fine a grain that the silk formed by three threads being put together comes under the name, at the least, of 15 *denari* (there were some even at 14 *denari*); and this silk, though extremely fine, is as strong and durable as that called 24 *denari*, produced from worms fed on the common mulberry. The stuff manufactured is, for fineness of texture, brilliancy, and quality, superior to the best hitherto known among us.

Now I have told you so many facts in favour of the new mulberry, although there are many of an opposite opinion, what do you say? and you will naturally ask, why? Because, in the better classes here, very little attention is paid to rural affairs, and they leave the subject entirely to their country agents or factors, to do as they please; and they have raised up a spirit of party amongst them, either because it is a cultivation that was not known to their fathers, or that they fear to have their delightful indolence disturbed by the novelty. They make their masters believe what they please, and by one opposition or another at last obtain their end. Indeed, there are some factors who make their masters believe that the silkworms will actually not eat the leaves of the new mulberry, and the poor fellows believe it.

In order to repair the scarcity of both the salad and the common oil which is now felt in our province, occasioned by the scarcity of oleaginous seed, such as *ravizzone*, flax, &c., on account of the late hoar frosts, which for some years have prevailed here, the *Pistacchio di terra* (*Arachis hypogæa*) has been thought of instead, and already all the scientific and agricultural journals extol it to the skies; and, to tell you the truth, they have said so much in favour of this vegetable, that many who sold it have received above 3 lire (Milanese) per lb. (12 oz. to the pound), and every proprietor has appropriated his little field to the cultivation of the *Arachis*; but this year every hope of success has vanished on account of the coldness of the spring, which was not warm till the end of June, and even to the 23d of July the temperature was so low, at five o'clock in the morning, as 10° ; whereas, in former years, the lowest degree of temperature at that time of the year was 16° , and that only for a few days. This depression was occasioned by the immense quantity of snow on the Alps, and even on the tops of the mountains in our neighbourhood; that is, those on the banks of the Lake of Como. But the cultivation of this plant is very uncertain, and does not leave much to hope for, as even the warmest arachidists will soon become cool. Several little works were published on the cultivation of the *Arachis* last year. The best and most to be depended on is by Abate Swagani, and I will send it to you by the first opportunity through the Baron Jacquin.

Root-grafting. I told you in my last letter that the director of the garden of Villa Traversi, in Desio, multiplied his roses by grafting on the root; and now I can tell you of its further extension, as it is practised by me not only on the rose, but also on the olive, berberis, cytisus, cratægus, &c. Wishing to graft in January and February (the most proper time), I take up the roots intended to be used for this purpose in November, because in January and February it would be difficult to do so, on account of the frost; and having put them in a corner of the *frigidario*, deep in the ground, care being taken that they do not germinate, I then leave them till the moment I wish to make use of them; and, when that time comes, I choose some healthy roots, that is, those without any defects, and about the size of a quill, or the little finger. I then cut them of the length of from 3 in. to 5 in., and make a vertical cut, and proceed as with split-grafting. I then plant them in pots of about 3 in. in diameter. As soon as they are planted, I cover them with a pane of glass, and put them in frames, or in the pine-stove; and, as soon as I see them beginning to grow, I give them air by degrees, and in a few days I take off the glass entirely, and allow them to enjoy the rays of the sun, which should also be done from the first day of grafting. By this process I have been enabled to graft from January to the end of July; and, in summer, I only use those roots of the rose that I think will not injure the plant, which must furnish roots to be again grafted the following year. The roots of the Chinese rose, and those of *R. multiflora*, are to be preferred, because, from what I have observed, they do not put out buds below the grafting, as is the case with *Rosa canina*, &c.; and by this means, in two months, plants will be formed, and produce flowers, particularly the variety of *Rosa odoratissima*. This kind of grafting is, in my opinion, preferable to the other, because the latter is not always successful, and requires a great deal of care, and as many as are wanted cannot always be obtained. The failure is only about ten in a hundred; and, from the observations that I and others have made on those that failed, I am convinced it was from the bad selection of the grafts, because they require to have good and healthy buds; and it is essential to choose vigorous shoots, that are neither tender nor immature, and that have two buds well nourished and formed. When I wish to graft anything in summer, when the plants are in full vegetation, as soon as I have fixed on the one that I wish to have grafted, I take off the extreme point of the branch that is to be the graft, and when I see the buds growing large I cut it off and graft it. This method of grafting has the advantage of not having the protuberance which is seen in plants split-grafted or by application, which amounts to a deformity, produces decay, and then death; whereas, by root-

grafting, only one wound is seen, well closed, and, from its proximity to the ground, in all probability when it is transplanted it will have the advantage of being put a little below it, so that the graft itself may put out roots, as I have already observed in several of them. I have seen a paper by M. Poiteau, in his *Revue Horticulturale*, on this method of grafting; also, perhaps, in the *Annales de la Société Hort. de Paris*; but the putting it in practice in summer is new, and that is the time when plants are in their full vigour. — *Giuseppe Manetti*.

[The foregoing communication was unfortunately mislaid after the essence of it had been used in the *Arboretum Britannicum*. On this account we entreat our correspondent and our readers to pardon the seeming neglect. We have now, we believe, inserted all the communications which we have ever received from Signore Manetti, and we hope he will be encouraged to continue them; for we are certain that all those of our readers whose taste rises higher than mere culture, who have, in fact, elegant minds, will read them with pleasure as well as with instruction. — *Cond.*]

ART. III. Domestic Notices.

ENGLAND.

THE Horticultural Fête at Chiswick, May 16.—It has never been our lot to see so many beautiful and rare plants collected in one place, as were yesterday in the Horticultural Society's Garden. The orchidaceous plants were in fine order, and were generally admired. Among the more remarkable were, *Phalænopsis amabilis* *Blume*, with its large white moth-like blossoms; the plant we were told had been in flower for nearly eighteen months; *Coryánthes macránthá* *Hook.*, having a lurid crimson flower unlike any thing else in nature, the labellum or lip being folded round almost like a sack; *Myánthus cérnuus* *Lindl.*, a fine plant with two long drooping spikes of dull green flowers, spotted with purple; *Cattlèya Móssiæ* *Hook.*, two very beautiful varieties with deep lilac petals, and a crimson labellum edged with white; *Acanthophippium bicolor* *Lindl.*, a very large plant producing yellow blossoms edged with red, close to the soil of the pot, in such masses as completely to hide it; *Aérides odorátum* *Lam.*, a most elegant plant with two drooping spikes, closely crowded with delicate white flowers, exhaling a most delicious scent; *Vánda Roxbúrhii* *R. Br.*; the rare and richly-coloured *Oncídium divaricátum* *B. R.*, and many others, too numerous to mention here, were in native beauty and vigour. These plants were principally supplied from the rich collections of Messrs. Rawlinson and Mr. Rucker. A very large quantity of heaths, all in fine flower, including nearly all the rarer kinds; one of the most remarkable specimens was a large plant of *Erica élegans* *Andr.*, from the Exeter Nursery, so completely covered with bright pink flowers as entirely to hide the foliage. A very numerous collection, including *E. Hartnélli* *Ro. C.*, *E. vestita* *Thun.*, and several varieties; *E. Thunbérghii* *W.*, *E. mirábilis* *Lod.*, and many others, occupied nearly the whole of one side of the central tent. The cacti from Mr. Harris, of which there were between 300 and 400 specimens, chiefly from Mexico, of all shapes and sizes. Mr. Cock's geraniums, and the innumerable variety of calceolarias, attracted universal attention. To describe the number and extraordinary varieties of *Calceolària* is impossible; suffice to say, that some were "rich in streaming gold," others of a deep velvet purple, others white, with a purple stain in the centre curiously marked with white; others again, having a white ground with a pink spot in the centre, very regularly marked with lines of deep crimson, &c., &c. The *Azálea índica* and its varieties, particularly *A. i. variegata* and *A. i. lateritia*, were deserving of notice; these, with the *Rhododéndron arbóreum* and its varieties, added not a little to the splendour of the show, by their large white, purple, pink, or red flowers. *Cèreus speciosissimus*, and *Epiphýllum Ackermánni* *majòr*, produced a gorgeous

effect, mixed with the white azaleas, from the large size of their blossoms, and their number. This group, from its brilliant masses of colour, quite defied the painter's art to depict, and ours to describe.

Of *Tropæolum tricolorum* there were many fine specimens in full flower, trained over wire frames, of all fantastic shapes. At a distance, the flowers looked like a number of little scarlet bells, or a green robe exquisitely embroidered with scarlet. The ixoras, with large orange scarlet heads of blossom, were among the most showy plants exhibited, and their flowers were well set off by the deep glossy foliage from which they rose. Perhaps the most remarkable plant of the whole was a seedling *Rhododendron* from Mr. Smith of Norbiton Nursery, with large yellow flowers, said to have been raised between *Azalea sinensis* and *Rhododendron maximum*. We cannot close without noticing that one entire tent was occupied by a collection of fine plants from Mr. Harris, including the cacti above mentioned. Notwithstanding the unfavourable weather of the morning, there was a tolerable attendance, and the general opinion seemed to be, that it was the best May show that had ever been seen in the gardens. — *W. A. M. May 16, 1840.*

Mr. Knight's Catalogue of Coniferae, just printed, contains : *Abies* 4 species and varieties ; *Araucaria* 4 species ; *Callitris* 1 species ; *Cedrus* 2 species ; *Cunninghamia* 1 species ; *Cupressus* 8 species and varieties ; *Dacrydium* 2 species ; *Juniperus* 17 species and varieties ; *Larix* 3 species and varieties ; *Picea* 15 species and varieties ; *Pinus* 55 species and varieties ; *Podocarpus* 4 species ; *Taxodium* 4 species ; *Taxus* 7 species and varieties ; and *Thuja* 6 species and varieties. In all 140 species and varieties.

Works on the Cacti are said to be in preparation by Zuccarini at Munich, and Dr. Lhotsky in London ; and the late Duke of Bedford had 80 species figured at Woburn, with a view to a splendid publication on this tribe of plants. This work, we understand, is suspended for the present ; but we have no doubt the present duke will resume it in due time.

Bedgebury Park, Kent, is at present the scene of very extensive improvements, under the direction of the very intelligent young gardener, James Finlay, formerly assistant to Mr. Wood at Deepdene. A new kitchen-garden has been formed, and also a new flower-garden, with an extensive range of hot-houses, pits, sheds, &c. Many miles of road have been laid out through the woods and farm lands, under draining extensively executed ; planting, and also thinning, existing plantations, carried on in various directions ; cows imported from Holland, Jersey, and Ireland, to prove which are the best milkers ; Colonel Le Couteur and M. Vilmorin's improved varieties of wheat have been tried, besides many other improvements connected with agriculture, gardening, and planting ; but being now on my commercial journey, I have not time to go into farther details. — *T. B. Tunbridge Wells, May 8, 1840.*

Wistaria sinensis, at Lavender Hill Nursery, is now (May 5.) well worth your inspection, for two or three things : 1st, The plant occupies a part of three sides of the house, and consequently gives three successive sheets of flowers on the three aspects. 2dly, The flowers are quite as numerous, and, perhaps, more beautiful, certainly of a deeper tint, and they last much longer, upon the east and north sides, than on the south side ; and, 3dly, there cannot possibly be found a more cutting or cold and exposed situation than that corner of the house which faces the north and the north-east, and yet the plant grows, flourishes, and blossoms most profusely, flowering also during the summer and nearly into the autumn again. The plant is this year very regularly covered with flowers, and the number of bunches is very great. — *W. Pamplin, jun. 9, Queen Street, Soho Square, May 5.*

The Vine at Valentines, once so celebrated, is now declining in health, and bears very sparingly. The branches, which used to fill a house 72 ft. long, are now not longer than 20 ft. The thickest part of the stem is 2 ft. in circumference. A fine myrtle in the green-house here 15 ft. high, with a trunk as many inches in diameter, and a magnificent conical head, was last autumn cut down to the ground, but is springing up again with vigour. — *J. J. Valentines, May 12, 1840.*

A Fine-Fruit Company has been projected by some gentlemen at Burton upon Trent. Coals and glass are very cheap there, and an experienced gardener in the neighbourhood says he can produce forced grapes at the rate of 3d. per lb., which may be sent to London by the railroad in quantities, not less than 50 lb., at a halfpenny per lb. We have often thought that something of this kind attempted in the neighbourhood of Lisbon, and to include the finer culinary vegetables, and winter flowers, as well as fruits, might succeed. — *Cond.*

Artificial Flowers and whole Plants have been very successfully made of feathers by Mrs. Randolph, 2. Bridge Street, Westminster, who has produced roses, carnations, camellias, chrysanthemums, and many others, almost equal to nature, and not only single flowers, but whole plants with leaves, buds, and flowers in all stages. The fairer part of creation, no doubt, will properly appreciate this elegant invention of Mrs. Randolph's, more especially if it were possible to infuse a little odour peculiar to the different species into the flowers. The prince of poets says that "woman unadorned is adorned the most," yet I cannot help thinking, however, that flowers are nature's own ornaments, and therefore will tend to heighten effect by their judicious use. By this invention ladies may be supplied with a summer bouquet for a ball at Christmas, which even an experienced eye would fail at a little distance to detect. At a meeting of the Horticultural Society on May 5., Mrs. Randolph exhibited some very beautiful specimens of her invention; among them I noticed whole plants of roses, particularly the sanguine China rose, chrysanthemums, camellias, and myrtles, in all of which she had been eminently successful. The carnations, the pinks, the wallflowers, and many other cut flowers were very beautifully executed, and with remarkable truth, both in form and colour. I have seen many beautiful imitations of flowers in wax and other substances, but they all have a certain stiffness which at once destroys the simplicity of nature, and shows you, too evidently, that they are mere imitations, but in Mrs. Randolph's feather flowers no such disagreeable effect is produced. — *W. A. M. May, 1840.*

A new Hedge-Pruner. — In these days of new inventions, I would beg to put in my claim for a new hedge-pruner, which I have, after three years' trial, found to make a very heavy process an uncommonly light one. I can with the greatest ease prune one side of hawthorn hedge 180 yards long and 6 ft. high, in the short space of forty minutes; and the cost of the whole apparatus will not exceed half the price of a pair of good scissors. If any of your numerous and intelligent readers or correspondents express a wish to have one, I shall send you every information respecting it, without any "consideration" whatever. — *James Wright. Watfield, March 28. 1840.*

A new Variety of Peach has been raised from a kernel of the Catharine, impregnated by the violette hâtive, by John Friend, Esq., of Birchington, in the Isle of Thanet. A paper on this valuable new variety, by Alderman Masters of Canterbury, was read at the meeting of the Horticultural Society, November 5. 1839, by which it appears to be a clingstone, with pale-coloured flesh, "very juicy, perfectly melting, and of a delicious flavour. It ripens somewhat irregularly during October, and has even remained good till November; thus lengthening the period during which fruit of the finest quality may be produced upon the open wall." It is Mr. Masters's intention to propagate this variety extensively, so that we trust it will soon become general in fruit gardens. (*See Proceedings of the Hort. Soc. of London, vol. i. p. 114.*)

Naked Barley, or Barley-Wheat; Hórdeum distichum Metzger, Europäische Cerealien, p. 49. t. 11.; Hórdeum nudum Thær; Orge à deux ranges nu, French; nackte Gerste, German; is strongly recommended by a retired medical gentleman farming his own estate near Newbury, Berkshire, as returning a greater profit than the variety of barley in general cultivation; and as it appears to us an excellent barley for cottage gardens, we insert what are stated to be its advantages. These are, —

1. It contains more flour than any other grain, rice excepted. 2. It weighs more than 60 lb. per bushel. 3. The flour is whiter and sweeter than common barley flour. 4. The flour absorbs more water than other flour, consequently produces more weight of bread. 5. Bread made from any barley flour is better made into thick cakes; and if from a 4th to an 8th of an ounce of carbonate of soda be dissolved in the yeast, it improves all bread, and takes the bitter away. 6. By plain boiling is good food for children. 7. The malt made from it increases more than from common barley. 8. The malt will make in seven days less than common barley. 9. It can be made one month earlier and one month later than from common barley. 10. It weighs considerably more than the malt from common barley. 11. The beer made from this malt is superior. 12. Three bushels will seed the land as well as four of other barley. 13. Should be sown in March or April. 14. It ripens in 80 or 90 days. 15. If sown without grass, can be harvested in two or three days. 16. If sown early will be harvested in time for a good crop of turnips. 17. It requires the same cultivation as other barley. 18. The straw is superior for fodder. 19. Seldom lodges, and not subject to disease. 20. Each acre of this barley produces about one third more food for human beings or animals. Seeds may be had of Messrs. Gibbs, Charlwood, and other seedsmen. — *Charles Aldermann Kenbury. Newbury.*

The Rot in Sheep. — *Hydrocótyle vulgàris*, *Drósera rotundifólia*, and *Pinguicula vulgàris* have been charged with giving the rot to sheep, and probably other plants. The following idea is perhaps new, but will it not explain some cases of rot which could hardly be attributed to a wet situation, such as where sheep have been upon rotting ground only a very short time? The eggs of the *Fasciola* are very minute and innumerable, and may easily be carried with the bile into the intestines, and thence voided with the dung. In wet fields they would be spread about and kept moist, which probably would preserve life, but in dry situations they would soon be killed, or if not killed, they would not be scattered upon the grass to be taken up by the sheep, as they might be in wet places. If they once enter the mouth, they would have no great difficulty in finding their way to the proper spot for their full development. The *Planària*, often said to be picked up by sheep and to be the *Fasciola* or fluke before it inhabits sheep, is a water animal of quite a different character. — *J. D. C. Sowerby. Pratt Street, Camden Town, Jan. 18. 1840.*

ART. IV. *The West London Gardeners' Association for mutual Instruction.*

MONDAY Evening, March 16. — Mr. Caie brought forward his paper "*On the Cultivation of Erica.*" He began as follows: "It may, with some truth, be asked, what can have induced me to write on the growth of *Erica*, a subject which has been treated so fully by men truly eminent for their practical knowledge. But what more immediately concerns me is the fact of the cultivation of the *Erica* being any thing but well understood at the present time. It is because I am quite sure that no plant merits a greater share of the gardener's care, and, also, because we know of few plants which evince less of it, that I have been induced to bring the subject before this meeting.

"It must be quite obvious to every gardener that the seed of a plant would remain inert until it rotted and perished, but for the influence of heat and of moisture; but what distinguishes a practical gardener is the application of these elements in unison with the state of the seeds, as well as their natural localities. The *Erica* is principally found at the Cape of Good Hope, which is in latitude 34° 29" south, and its elevation at the Table Mountain above the sea is 3582 ft., which renders it an airy situation. In sowing the seeds of *Erica*, the sizes of the pots or pans should be regulated according to the greater or less quantity of seed to be sown. When so arranged, get a portion

of peat earth chopped up; put a crocksherd in the bottom of the pot, then fill it with the turfy peat earth to within $1\frac{1}{2}$ in. of the rim of the pot; after which rub some of the peat earth very fine, and fill up the remaining part of the pot with it, then press it evenly down, so much so as to admit of sowing the seed as well as covering it, which should be done with a fine sieve, and just sufficient to cover the seed, when a very fine rose watering-pot should be used in damping and settling the earth, previously to the pots being arranged in a cold frame; where they should be plunged in cold ashes at 2 ft. from the glass, and the lights to be kept on until they vegetate. If sown very early in the spring many of them may be potted off the following autumn into small 60-sized pots, to the number of five plants in each pot; then placed in a cold close frame for a week, when they may be gradually hardened; such of them as will not admit of potting must be placed in an airy situation in the greenhouse or heathery, not more than 2 ft. from the glass; and such a place is equally well adapted for those that have been potted off.

“To increase the *Erica* from cuttings requires more care on the part of the gardener; but, when a knowledge of the natural habits of the plant is attained, his success will be almost as sure as raising them from seed; in fact, in numerous instances, more so. I have been in the habit of putting cuttings in every month of the year; but, for my general stock, I prefer February, March, April, and May. In preparing for this, it is necessary to get a quantity of white sand, or sand similar to it in purity, though of a different colour; but, previously to using, it ought to be thoroughly washed, so that the water, when poured off, should have a clear appearance. The pots for receiving the cuttings must be well cleaned, and 3 in. of drainage put in, on which put turfy peat earth to within 2 in. of the rim of the pot; then fill up the pot with the sand, water and press it firmly down; then take the bell-glass, and mark out the space allotted for the cuttings. Having the pot clean, the sand pure, and a very sharp knife, select the shoots that are of such a texture as, in cross-cutting (that is, at a right angle with the cutting) close under a tier of leaves, will not be bruised, which I consider a good criterion to judge of the fitness of the cutting. The cutting should be held in the left hand, between the forefinger and thumb; then part the leaves, and cut them on the thumb nail; two tiers of them will be sufficient to be cut off, as I have often found, with a sharp knife, that cuttings would send out roots at the tier next the surface. Then with a small dibble insert the cuttings in the sand, in rows, and place on the outside of the bell-glass a tally, with the name of the *Erica* it precedes, as well as the day of the month when put in. If more than one species is put into a pot, their time of rooting should be as similar as possible, or much trouble will be occasioned. I do not excite the cuttings as soon as the pots are stocked, I rather prefer a colder temperature for them at this time; as, when they are accelerated, there is less danger of their damping off; because, by so treating them, a greater firmness has been obtained, and, consequently, they are more likely to resist any unnatural forcing that may be applied, or any inattention they may have experienced during their course of propagation. After such treatment as I have recommended, they may be put into a hot-bed where the heat has quite subsided, with the bell-glass over them during the day, and shaded in sunny weather; but, under such an exclusion of light, I never fail, when the nights permit, to take off, not only the bell-glasses, but also the lights, as, by so doing, I adhere to the principle of maintaining the hardness in the cutting, by which we facilitate its rooting; if this is not strictly carried out, we merely elongate the cutting to the injury of its rooting. As the great proportion of the cuttings will be rooting during the summer, I never fail in potting them off as they are rooted. For this purpose some peat earth should be kept in store: previously to using, it should be well rubbed through the hands, and any very rough pieces taken out; but by no means cleaned of that vegetable substance which it possesses, when not taken at too great a distance from the surface; then add one part of sand to two of it. The same-sized pots which were used for the seedlings will do for cuttings, and the same number of

cuttings in each pot as before recommended. The pots should be well drained with rough peat earth. The cuttings should be watered soon after they are potted, and then put under hand-glasses on a shady border during summer; and, as they get established in their pots, remove them to a shelf in the greenhouse, as recommended for the seedlings; such of them as are still in the cutting pots may be put in a hot-house, but not in a very hot or dry situation. The bell-glasses will require to be wiped frequently, and the cuttings regularly watered.

“ Having treated of the *Erica* in its seedling and cutting states, I shall now advert to its more mature growth. Having alluded to them when they were five in a pot, which was in the spring succeeding their seedling and cutting states, and when they have grown too large for their pots, and consequently want shifting, this is done by carefully removing each plant with a ball attached to it, and potting it singly in a pot, similar to those from which they have just been taken, noticing to keep the ball of earth still uppermost, but planted below the rim of the pot; then set them in rows or groups, when they should be named and placed in a cold frame, arranging them alphabetically, according to their names, in order to see more readily the number of each sort, and, consequently, the duplicates to spare. They must be regularly watered during the summer months; but, if very rainy weather, the lights should be kept on; as a plant in a pot fully exposed is much more likely to be injured than if it were really planted out. As the winter approaches, the same routine they underwent the previous winter is no less applicable in the present instance.

I have now arrived at the third year since the *ericas* were seedlings and cuttings; and, as much can be said in this stage of their growth applicable to future years, it is my intention to do so. I set out with the idea of being anxious to stock a heathery, and to grow some plants for ornamental purposes. To attain this, the first and paramount object should be, to get some good peat earth, taken from a high and dry situation, full of nutritive vegetable matter; and, as its fertilising property ceases in proportion to the depth we go, hence the utility of not cutting it out much deeper than 7 in.; this observation must never be forgotten in the growing of *Erica*, nor, in fact, with any other plant. A portion of the peat earth should be broken up, and, if not of a sandy nature, let it be made so; clean and drain a number of 48-sized pots; then put over the potsherd or sandstone some rough pieces of peat earth, the roughest side next the drainage, and fill the pot sufficiently to admit the ball of earth attached to the plant; and take great care that the surface of the ball is just level with the pot, because it is at this shifting that thousands of *ericas* have been irrecoverably injured, in consequence of placing such balls perhaps 1 in. above the pot; and the result of such potting is, that as soon as the hot weather sets in, what with the heat the pot radiates, and the heat the peat earth is susceptible of retaining, we water and water, but still the plant looks sickly or dies; we turn it out of the pot, and see the roots apparently healthy, but, behold, all above the pot are burned. I have stated how the plant should be potted at this stage of its growth, and to what I attribute so many deaths, and the same principle holds good with the *Erica* in a more advanced state of growth; because those roots which in the former instance were fibrous have now, in a great degree, assumed much of the nature of the bole or stem of the plant, from their having been brought up in proportion to the size or protective nature of the plant against the sun's rays. When the *Erica* is in a growing state, the stopping of the shoots should be attended to, as it gives them a bushy appearance, and prevents the necessity of staking, which is injurious, and inconsistent with their natural habits of growth. As the size of the *Erica* is, so should the roughness of the peat earth be with which it is potted. *Ericas*, to succeed fully exposed to the influence of the weather, should be potted some time before they are set out. A partial shade is necessary, and particularly so if the pots are exposed to the sun's rays; as I have noticed that, in proportion to the number of hot days, so were the sickly appearances of the

plants; the pots being conductors of heat, of course the roots that came in contact with them were injured. But, to show more clearly what I mean, as well as to explain how large plants of *Erica* may be grown in one year, I prepare a border, in a similar situation to that where the *Ericæ* were standing in pots, to the depth of 2 ft., with turfy peat earth; then select a number of duplicate plants (because a plant or more of the valuable sorts should not be exposed to the weather, but kept in frames or green-houses), and plant them at 18 in. or 2 ft. apart. These by the autumn will have grown into bushes, when the following directions must be strictly adhered to. In taking them up and potting, they should be lifted with balls according to their sizes; pots or wooden boxes should be got so much larger than the balls of earth as not to retard the growth of the plant. They should be potted in rough peat, and set on a shady border for a week or more; watering them over every dry day during the time they are there, when they should be brought out to an open and airy place, in order to prepare them for the green-house or heathery; but still a free admission of air should be allowed, except in frosty weather. This brings me in connexion with the heathery or green-house, on which I have some remarks to make respecting its construction. It has been the object of this paper to advocate the utility of light and air to *Ericæ*; but it will not appear less obvious that when I have alluded to these elements I have always guarded against any injurious consequences that might arise from them by change of season or situation, and it is to that end I now state that, of all houses for plants, a heath-house should be so constructed as to resist the most frost, and have the greatest command of ventilation, and so that the plants in it will not be at a great distance from the glass. I have said that air was indispensable to their health, as it hardens them for such a gradual transition as to allow a degree or two of frost without injury. I have seen more frost than this in a heath-house, but the bad effects were soon apparent; for this reason, that the house was easily affected by heat or cold, and hence the danger of frost getting into it, because of the plants being so soon excited after being frozen. I am quite sure that *Ericæ* may be wintered in pots, and have more frost than plants in a heathery, and still not be greatly injured, as they may be protected from the sun's rays till the frost has been gradually brought out of the plants, then all their relative parts act and are affected alike by the sun's rays. If fire is given, which I consider it should be, when the thermometer falls to the freezing point, the plants can be kept healthy throughout the year. Water should be carefully given in winter, taking care that the mould does not get sodden; if any appear so for some days, look at the drainage. Syringings to be given in the morning in fine weather in winter, and in the afternoon in summer or the spring months, and every now and then shake sulphur over the foliage, which prevents mildew; damp increases it, hence the utility of free ventilation. The following is an example of what I have alluded to in the foregoing paper, as regards the selection of cuttings having an affinity to each other when inserted in one pot:

	Sect. 1.	
<i>Erica tenélla</i>	<i>Erica ignéscens</i>	<i>Erica concinna</i>
<i>grácilis</i>	<i>fláunmea</i>	<i>Cliffordiana</i>
<i>insúlsa</i>	<i>elàta</i>	<i>Persóluta</i>
<i>procúbens</i>	<i>sulphúrea</i>	<i>rubélla.</i>
<i>rúbens</i>		
	Sect. 2.	
<i>flagellifórmis</i>	<i>lùtea</i>	<i>álbicans</i>
<i>paniculàta</i>	<i>tetragóna</i>	<i>pulchélla</i>
<i>Actoniána</i>	<i>conférta</i>	<i>calycinóides.</i>
	Sect. 3.	
<i>pícta</i>	<i>folliculàris</i>	<i>demíssa</i>
<i>Plukenèti</i>	<i>melástoma</i>	<i>epistómia.</i>
<i>Petivèri</i>	<i>sacciflòra</i>	

<i>Erica costata</i>	Sect. 4.	<i>Erica fràgrans</i>
<i>speciosa</i>	<i>Erica viridiflora</i>	<i>mirabilis</i>
<i>bicolor</i>	<i>sanguinea</i>	<i>Bonplandiana</i>
<i>versicolor</i>	<i>Bowiciana</i>	<i>primuloides</i>
<i>bucciniformis</i>	<i>coccinea</i>	<i>Coventryana.</i>
	<i>ventricosa</i>	
<i>Archeriana</i>	Sect. 5.	<i>aristella</i>
<i>Sprengelii</i>	<i>ampullacea</i>	<i>tricolor</i>
<i>inflata</i>	<i>Shannoniana</i>	<i>Hartnellii.</i>
<i>jasminiflora</i>	<i>retorta</i>	
	<i>aristata</i>	
<i>Pattersoniana</i>	Sect. 6.	<i>cerinthoides."</i>
<i>Linnæana</i>	<i>Bedfordiana</i>	

Mr. Sherwood listened with pleasure to the excellent paper just read by Mr. Caie. He did not approve of the system of raising the bole of the *Erica* higher than the rim of the pot. He would plant them half an inch below the sides of the pot, as he considers, when they are watered, their roots are distended; they are consequently elevated before they are in a fit state to be shifted into larger-sized pots.

Mr. Fish observed, that if one tribe of plants required our special care, or were more beautiful than another, it was the *Erica*. The best cultivators of heaths adopted the plan of raising the ball above the sides of the pot, and with success. Air and light seemed indispensable for the well-doing of the plant, and a situation where they may be exposed to the genial influence of the sun, and capable of free ventilation at all times. He prefers to sow the seed in sandy peat early in spring. He admired the system recommended by Mr. Caie of keeping the sorts similar in species together. The foliage of heaths can, without injury, bear intense sun; but ruinous effects are produced by the sun's rays heating the pots and burning the roots; plunging them in sawdust he found would act as a preventive to such destructive effects; 35 would be the lowest degree of temperature he would wish to see in a heath-house.

Mr. Keane considered the paper brought forward by Mr. Caie to contain excellent practical observations on the propagation and culture of the *Erica*. He recommended that moss should be placed on the pots during the intense sunshine of summer, which would retain the moisture and prevent evaporation. He was opposed to the experiment of exposing the *Ericæ* to the influence of frost, for, although they may not immediately appear to suffer, he believed that it would lay the foundation for diseases which may be accelerated or retarded by subsequent treatment. He considered the *Ericæ* was most difficult to be successfully grown, and which was confirmed by the general remarks of all practical writers on the subject. He did not think that they were likely to suffer by too much water, as the heath soil is so porous it would pass off in sufficient time to prevent the ill effects which follow from a stagnation of the water in the soil.

Mr. Caie would recommend all *ericas* to be shifted in the autumn, to keep them growing. He did not desire the total exclusion of light in the pits, but that they may be gradually inured to the light as the relative parts are brought into action.

Mr. Fish agreed with Mr. Caie in procuring the top spit which contains more vegetable and nutritive matter.

Mr. Grey also coincided with Mr. Caie in the benefit of using the top spit. As the heat of the sun in summer is the principal cause of burning the plants, he placed one pot within another, and filled the intervening space with moss, which retains the moisture, and prevents the injurious effects so generally observable with heaths in summer. He believed that the system recommended by Mr. Caie very much simplified the culture of the *Erica*. It was like most of the secrets of art; when known, they are found to be perfectly simple.

Mr. Keane agreed with the hint thrown out by Mr. Grey, as it was generally admitted that the heaths suffered by the heat which is communicated to the roots by the sunbeams striking against the sides of the pots, and which would be obviated by the moss as recommended. As the *Ericæ* are apt to mildew, he advised to syringe them freely until it is washed quite clean from the plants, then give them as much air as possible, and by a free ventilation on a fine day they will soon become dry and restored to life and vigour.

Mr. Caie explicitly replied to all the observations made upon his paper, and remarked that he became acquainted with the West London Gardeners' Association through the kindness of His Grace the late Duke of Bedford, who first directed his attention to the subject, and whose memory he should ever revere, as in health or in sickness His Grace never ceased from doing good. The subject of heaths occupied his mind during one of the trying scenes of his busy life, and gave rise to that extensive collection at Woburn Abbey, where he (Mr. Caie) gathered the facts detailed to the meeting that evening.

ART. V. *Regulations for the internal Administration of the Garden of the Horticultural Society of London.* (Extracted from the Minutes of the Garden Committee, and ordered by the Council to be printed, Feb. 13. 1840.)

1. THE management of the Garden of the Horticultural Society is intrusted by the council to the garden committee, who meet once a month at least ; and during the intervals of their meetings, to the Vice-Secretary.

2. Under their direction the immediate superintendence is vested in the head gardener and three under gardeners.

3. For this purpose the garden is divided into three distinct departments, each under the separate charge of one of the under gardeners ; who are held responsible for the good cultivation of the plants under their care, and have power to determine what modes of cultivation are most proper.

4. These departments are as follow :—

(1.) The orchard and kitchen-garden department, including the houses for forcing fruit and vegetables, and the ground adjoining.

(2.) The hot-house department, including the green-houses and other houses, pits or glazed buildings, now existing or hereafter to be erected, for the cultivation of tender plants, together with all the grounds enclosed within the walls of what were formerly called "Experimental Gardens," with the exception of such part as may be occupied by the orchard and kitchen-garden department.

(3.) The hardy department, consisting of the arboretum, flower-garden, and all the cultivated ground not occupied by the two other departments.

5. The packing and distributing of seeds, plants, &c., to the fellows of the Society, is independent of the above departments, and under the immediate and personal superintendence of the head gardener.

6. The men permanently employed in the garden are exclusively received on the recommendation of fellows of the Society.

7. The only exception to this regulation is in favour of foreigners, of whom no more than two may be employed at the same time.

8. The names and addresses of the candidates for admission are entered in a book, in the order in which their recommendations are received.

9. Notice is then transmitted to the candidate of the points upon which he will have to give satisfactory evidence before he can be received into the garden, which are as follow :—

(1.) That he has been employed for at least three years in some good garden.

(2.) That he can write and spell respectably.

(3.) That he is sufficiently acquainted with arithmetic to be able to keep accounts.

(4.) That he is able to measure land, and make simple ground plans.

10. In case of a permanent vacancy in any one of the departments, that vacancy is filled up by the first on the list of candidates for admission, who is received upon complying with the above regulations; but, in the case of a vacancy being temporary only, then it is filled up by an extra man, engaged by the under gardener, in whose department the vacancy occurs.

11. The men are successively employed in the three several departments, the transfer from one department to another taking place under the following regulations:—

(1.) There are two days in each year on which the men are transferred, and no transfers are allowed to take place on other days, such transfer days being February 1. and August 1.

(2.) On each transfer day a number of men, not fewer than one half, and as near that number as may be, are removed from one department to some other.

(3.) On this occasion each under gardener selects for transfer the seniors in his department, with the privilege of retaining any one or two of them until the next transfer day, provided the men are willing to stay with him.

(4.) When all the vacancies and persons to be transferred are declared, the men to be transferred have the right of choosing for themselves to which vacancy they will be appointed, the choice being given to them in the order of their seniority. The term seniority is always understood as applying to the period of employment in each department, and not in the garden generally. But if more men apply for admission into a department than there are vacancies, in that case the transfer is arranged by consultation with the applicants.

(5.) On each transfer day the under gardeners make out and sign returns, declaring what the conduct of each man transferred has been during the time he was employed under them; for which purpose printed forms are issued.

(6.) These returns, together with the general result of the transfer, are laid before the first garden committee which may meet after the transfer day. The returns are afterwards filed, and the substance of them is expressed in the certificates granted to the men under the regulations hereinafter given.

12. Previously to being recommended to a place as gardener, every man must pass an examination in measuring land, making ground plans, geography, the elements of botany, and vegetable physiology.

13. When any person employed in the garden is ready to undergo such an examination, he gives notice in writing to the Vice-Secretary, who appoints the time and manner in which the examination is to take place.

14. No person is, however, allowed to proceed to examination until he has passed through every department in the garden; and no examination is held in the months of December, January, February, March, or April, without the special permission of the committee.

15. The result of the examination is recorded in a book kept for the purpose; if it be satisfactory, a certificate to that effect is granted, and the person examined is entitled to be recommended to a place, provided his general conduct is approved of. The standard of qualification is placed very low by the committee, in order to render the system of examination applicable to all capacities; but the examiner has directions to raise it in those cases in which men desire it, and the certificates are varied accordingly. Of course those persons are considered qualified for the highest places whose examinations are the most successful.

16. The qualification of the person examined is stated in the body of the certificate, without any distinction in the form or class of such certificate, which also expresses the substance of the several under gardeners' reports of the conduct of the man whilst he was in their respective departments.

17. The examinations are verbal and private, and the result of each ex-

amination is reported to the first garden committee which may meet after it has taken place.

18. If a man does not pass his examination within three years after his admission into the garden, he is liable to be dismissed by the garden committee.

19. The time-bell to summon the men to work is rung by the man on duty in the hot-house department, in the morning at daylight in winter, and at six o'clock in summer, except on moving mornings, when it is rung at five o'clock; it is rung again at eight for breakfast, and at half-past eight for return to work; at twelve for dinner, and one for return to work; and in the evening, for quitting work for the day, at dusk in winter, or six o'clock in summer, the time being regulated by Chiswick church clock.

20. All the men employed in the garden enter at the National School gate, where a person is stationed with a book, in which the names of those entering are fairly written by themselves: and he continues to receive the names until five minutes after the hour in the morning at which the bell for summoning to work shall have ceased to ring; after which time no entry is made. Those who arrive after the expiration of the five minutes, have their names inserted in a separate book, and are fined sixpence each, or in case of their not presenting themselves until breakfast time, are then fined one shilling each. A weekly return of the names, and days on which men are late in the morning, is made by the clerk from this book, which return is regularly entered in a register laid before the garden committee at each meeting.

21. It is the duty of the under gardener in the hot-house department, to furnish the person who attends to the National School gate.

22. A fine of sixpence for each square of broken glass is regularly levied upon breakers of glass through carelessness, and with that view each under gardener reports weekly, in writing, to the gardener, what glass in his department requires repair; whereupon the gardener examines such report, and having ascertained what fines are to be levied for the breakage, and entered them in the fine-book, countersigns the report, and gives it to the carpenter, who is to consider it an order for the repair of the breakage. The carpenter preserves these orders, and lays them before every garden committee, when an abstract of them is regularly entered in the minutes. The under gardener's reports express the number and size of the squares broken, and the houses or other buildings to which they belong; and the carpenter is not allowed, on any pretence, to make good any broken squares which he does not find in such reports.

23. All fines levied on the men under the foregoing regulations are entered in a book, and the money accumulating from such fines is expended in the purchase of books for the use of the men.

24. All messages to a distance are performed by messengers taken from the three departments of the garden alternately, their names being entered in a book kept for the purpose. Messages to short distances are considered to be within the province of the man on duty in the hot-house department.

25. No persons can be admitted into the garden on Sundays, on any pretence whatever, except by the personal introduction of the gardener or under gardeners, who can give permission to the men to see their friends; care being taken that this permission is granted sparingly, and only on behalf of persons of the same class as the men themselves. The names of all persons so admitted are written in a book kept at the gate.

26. No person, however, can be admitted into the garden on a Sunday, under the previous regulation, until after the hour of Divine service in the morning.

27. If a man is unable to come to his work, his wages are stopped for two days; if he continues ill, half-pay is issued to him till the next meeting of the committee, when his case is reported, together with a statement from the Society's medical adviser, as to the nature of his complaint; whereupon the Committee order the whole or any part of his pay to be given to him, or remove him from the Society's service, according to the circumstances of the case.

ART. VI. *The Competition Designs for laying out the Gardens of the Royal Botanic Society of London, in the Inner Circle, Regent's Park.*

THE following are the "Instructions for the Guidance of Candidates" which were issued by the Society in February last:—That a large portion of the ground shall be applied to a geographic arrangement of plants, or a distribution of plants, in about twelve separate compartments or groups, corresponding to the principal floras of the globe, such as the Arctic Regions, the North of Europe and Asia, England, the Mediterranean Region, China and Japan, India and the adjacent islands, North America, Mexico and the West Indies, South America, the South of Africa, Australia, and New Zealand. That this part shall comprise one or more conservatories or hot-houses; provision for water plants, and others of peculiar habits; lawns, with spacious terraces or other walks: the whole so disposed as to be at the same time instructive and ornamental. That gardens on a suitable scale shall be provided, so laid out as to accommodate professors and their pupils in the study of plants, under the five following heads:—1. Medicine; 2. Agriculture; 3. Arts and Manufactures; 4. Scientific Arrangements; 5. Experiment. That sites shall be provided for,—

1. Buildings to contain lecture-room, library, museum, &c.
2. Curator's and gardener's dwellings.
3. A nursery, with other necessary appendages and offices.
4. An entrance-lodge, which it is proposed shall be on the east side, opposite to Chester Terrace, where the gate now is.

That the plans generally, and particularly as regards the conservatories and other buildings, be so arranged as to admit of being executed progressively; and that the present buildings and walks upon the gardens be preserved, as far as possible, either permanently or during the execution of any new general arrangements. That it is not desired to have the designs exhibiting in detail the arrangements and construction of the buildings, but only the size and situation recommended for them. For the convenience and gratification of the public admitted into the gardens, it is proposed that there should be wide terraces or other walks connected with an extensive lawn, and the whole decorated in such a manner as to be rendered as attractive as possible. The arrangements should be in all respects complete for the objects of an ornamental as well as a scientific garden, as far as they can be made so consistently with a strict regard to economy. That the belt of trees surrounding the ground, and the reservoir within it, be preserved. That the plans be all drawn to the scale of 50 ft. to 1 in., and be delivered on or before Saturday, the 4th day of April, 1840.

The following is a catalogue of the designs given in and exhibited in the Society's rooms, in Pall Mall, from April 8. to May 9.

1. Plan of the ground in its present state.
2. H. P., Spring Terrace, Wandsworth.
3. John Aiton, Mr. Pearson's Nursery, Hampstead Road.
4. and 5. Martin Joseph Stutely, Architect, Gower Street, Bedford Square.
6. Richard Bainbridge, Flower-Gardener to Lord Wenlock, Eserick Park, near York.
7. Alfred Bartholomew, Architect, Warwick House, Gray's Inn.
8. W. Billington, Architect and Civil Engineer, Wakefield.
9. John Burges Watson, Architect, 39. Manchester Street, Manchester Square.
10. John Thompson, Landscape-Gardener, &c., late head gardener to his Grace the Duke of Northumberland.
11. H. Heathcote Russell, Springfield Lodge, Garrat, near Wandsworth.
12. Edwin E. Merral, 35. Park Lane, Leeds.
13. Henry Laxton, F.L.S., Architect and Landscape-Gardener, 70. Berner's Street.
14. and 15. Charles J. Nicolay, Elm Grove Cottage, near Winborne, Dorset.
16. Wyatt Papworth, Architect, 10. Caroline Street, Bedford Square.
17. Edward Lapidge, Derby Street, Parliament Street.
18. and 19. Henry Laxton, F.L.S., Architect and Landscape-Gardener.
20. G. A. Chef-

fin, Architect, 1. Lees Street, Piccadilly, Manchester. 21. R. H. Essex, 13. York Buildings, New Road.

The Competition Designs for the Botanic Society's Garden in the Inner Circle, Regent's Park, were opened for public exhibition on April the 8th. They are 20 in number, and almost all by architects. We have glanced over them once, and shall probably have to speak of them more in detail on some future occasion. In the meantime we cannot help expressing a feeling of something more than disappointment on seeing so many designs, and yet not one among them that, even with considerable alterations, would, in our opinion, be fit to be executed. We could name a score of gentlemen's gardeners, any one of whom would produce a better plan than the best in this exhibition. It is singular that in a country celebrated for its landscape-gardening and its horticulture, such a number of designs should have been produced of so little merit. — *Cond.*

The above was written on returning from the exhibition on the day when it was opened. We have since examined the plans twice, at the request of the Council, in order to aid them in deciding to which plan the prize ought to be awarded, and we see no reason to alter the opinion first formed. There is not one of the plans, as we think, fit to be executed, even with considerable alterations, supposing the Society to be rich enough to do so. All that the Council can do, therefore, is to determine which of the competitors has best complied with the conditions laid down in their "Instructions." The premium, fifty guineas, has not yet been awarded.

ART. VII. *Retrospective Criticism.*

THE Advantage of placing Hot-water Pipes higher than the Boiler. (p. 227.) — Your intelligent correspondent, W. of Darlington, deserves my thanks for his clear explanation of the mistake into which Mr. Beaton had fallen on the subject of conical boilers; and the least acknowledgement I can make him is to answer his own questions as far as I can.

He wishes to know what is the advantage of placing "the pipes much higher than the boiler; and considers 1 ft., my minimum, as quite sufficient." Under ordinary circumstances, and perhaps always with 4-inch pipe, it is sufficient; but where smaller pipe is employed, it may be desirable to have the pipes considerably higher above the boiler. The moving force, and, consequently, the velocity of circulation, depend upon the difference in weight between the ascending and descending column: now, the greater the height of these columns, the greater the difference in their weight; and, consequently, the greater the velocity of circulation, and the higher the mean temperature of the pipes. With 4-inch pipe this is unimportant, for the volume of water contained in them is large as compared with their radiating surface; so that, with any given velocity, the water loses less heat in one circulation than it would in smaller pipes. Moreover, in 4-inch pipes the friction is small, and offers little resistance to circulation, so that in 4-inch pipe there is little need of very rapid circulation, and little resistance to such circulation: but with smaller pipe there is need of more rapid motion, or the water in the return pipe will be much colder than in the delivery pipe: to take the instance of 2-inch pipe, and suppose the circuit of equal length and the velocity equal in both cases, the difference of temperature between the flow and return pipes will be four times as great as it would with 4-inch pipe, because the volume of water conveying heat is only one fourth of that contained in the larger pipes. It is true this difference of temperature increases the difference of weight in the column, i. e. the moving force, and the supposition of equal velocities does not hold good in practice; but with increased velocity comes increased friction; and, moreover, with diminished diameter comes increased friction also; so that, with the boiler of the same height, it is impossible to heat a given length of 2-inch pipe to the same mean temperature with an equal length of 4-inch.

But there is yet another disadvantage to be taken into account on the score of the 2-inch pipe, which is this; that, as a given boiler is calculated to supply, say 100 ft. of radiating surface, if this 100 ft. of surface is exhibited in the form of 200 ft. of 2-inch pipe, instead of 100 ft. of 4-inch, you have not only the increased friction due to the diminished bore to contend with, but also the increased friction due to a doubled length of pipe; so that, in order to bring the radiating surface of 200 ft. of 2-inch pipe to the same mean temperature as 100 ft. of 4-inch, you require a great increase of moving power, i. e. a great elevation of the pipes above the boiler.

All, however, that I meant to say, was, that wherever such arrangement was practicable, or as far as it was not inconvenient, the whole of the pipes should be placed above the boiler; 1 ft. is sufficient, and would be sufficient in all ordinary cases, even with 2-inch pipe, but the higher the better; for the higher the pipes are above the boiler, *cæteris paribus*, the greater will be the economy of fuel, inasmuch as the heat will be carried off more rapidly from the boiler. It is a possible condition that small pipes might be properly placed and perfectly free from air or other impediment, and yet that the water in the boiler should boil to waste in steam, although the mean temperature of the pipes fell far short of 200°; simply because, in a very long length of pipe, if it be laid level with, or only just above, the top of the boiler, the moving force would not be sufficient to overcome the friction. I do not mean to say that this was Mr. Beaton's case, it is highly improbable that it was; but still it is a possible case if the pipe be not high enough above the boiler; and such defect may be continually seen, even with 5-inch pipe, in the earlier hot-water apparatus, the boilers of which were extremely shallow. The foregoing explanation will, I trust, be intelligible; if it be not intelligible, I must request your correspondent to refer to Mr. C. Hood's work, where he will find data which establish my statements. With respect to his suggestion that the form of a limekiln (I presume, an inverted cone) would be advantageous, I do not exactly see how it would operate advantageously; and I fear that the fire would be speedily choked up with ashes and clinkers so as to go out, or that it would be extinguished at bottom by the rapid radiation of heat from a small body of fuel into the water, and continue burning only at the top. With respect to the absolute quantity of water which any boiler would heat to boiling, a little reflection will, I think, show, in the first place, that it is a question not admitting a definite answer, and that, if answered, it could lead to no practical result.* A few observations on the subject of steaming houses will be found in another place (see Art. I. p. 281.).—*J. R. Sevenoaks, May, 1840.*

Mr. Penn's Mode of Warming and Ventilating.—The fair and open manner in which you admit the suggestions of correspondents, although opposed to your own opinions, induces me to offer a few observations on the improvements in hot-water apparatus published in the last two Numbers of your valuable Magazine; and, first, allow me to make a few remarks on [We have omitted those on the expression "inverted cylinder," because, as appears at p. 272., it is simply an error of the press] Mr. Beaton, who thinks *he* ought to have found out Mr. Penn's method of ventilating hot-houses some years ago. I quite agree with him in this, and think he has a very fair claim to divide the palm with Mr. Penn; his experiment being equally as *original* as the other; and both their discoveries are as novel as the introduction of chimneys, which, I think, antiquarians refer to about the thirteenth or fourteenth century. There is, in fact, nothing whatever that is new in this circulation of air; the very same cause which produces the draught of air up a heated chimney causes the circulation in Mr. Penn's system, and also was the cause of the phenomenon which Mr. Beaton describes (p. 229.); and it appears to me perfectly absurd to suppose that by the former of these modes the air is *prevented* from

* A statement of the quantity of heat which may be obtained from a given quantity of fuel consumed in one of the three boilers, will be found in our April Number, and this is probably the purport of W.'s query.

becoming stagnant. The stagnation of the air is absolutely impossible in any building having a large cooling surface of glass, and with hot-water pipes giving off heat. As well might the ocean, with its ever-rolling waves, be supposed to stagnate, as the air of a house under these circumstances, whether heated on Mr. Penn's or any other system. The air may become very foul, from the gases given off from the plants which the house contains; but this must also be the case with Mr. Penn's plan in common with all others, unless an express provision be made for a renewal of a portion of the air, which does not appear to be the case in the plan [When it appears desirable to change the air of the house, this is not done by opening the sashes in the usual way, but by taking the stoppers out of two openings into the back drain, which contains the hot-water pipes, &c.] proposed by him. There are, however, some objections to Mr. Penn's system which seem to me to be quite fatal to its adoption, unless he can devise means for obviating the difficulty. By this plan the whole of the pipes are placed in a situation where it is impossible to get at them to remedy any defect which may chance to arise by the fracture of a pipe, the unsoundness of a joint, or other casualty, to which this apparatus, in common with all others, is occasionally liable. But another and still more important objection appears to me to be, that the tunnel or drain in which these pipes are placed will become the receptacle for all kinds of insects, fungus, decayed leaves, and every other description of unwholesome contamination; and that, however fair without, it will within be "full of all uncleanness." The extremely damp state in which the tunnel is proposed to be kept will materially promote this effect; and I cannot but think that the insects and the various fungi which will lodge therein will in a short time be sufficient to contaminate the whole atmosphere of the house and materially injure the plants. Perhaps some of your readers can suggest a remedy for this; but, for myself, I do not see how it is to be obviated. In considering the objects which Mr. Penn proposes to accomplish by his new arrangement, I cannot think that there is any thing in the plan to justify the great additional expense which must necessarily be the consequence of its adoption. I perfectly agree with what Mr. Rogers stated in your March Number, that in every case where a house is warmed by hot-water pipes the same circulation of air is continually going on as in this method of Mr. Penn's; and if this be the case, and if the objections I have urged above have any weight, then, I think, every unprejudiced person must arrive at the conclusion that this plan is in reality a retrograde movement in the march of improvement, and one which is by no means likely to stand the unerring tests of time and experience.—*Benjamin Fowler. 7. Palsgrave Place, Strand, April 18. 1840.*

Our readers will bear in mind, that whatever has been said in this Magazine in favour of Mr. Penn's plan has been said by us, and not by Mr. Penn; and therefore Mr. Penn is by no means obliged to take any notice of what our correspondents state on the subject, whether complimentary or otherwise. It is very natural that those who have been accustomed to heat successfully in the usual manner should be induced to notice a new mode, which we have so strongly recommended as we have done that of Mr. Penn; and we think it but fair that such parties should be heard in their own defence, and the arguments they adduce allowed to have their full effect with the public. We have nothing to add to our account of Mr. Penn's method; but, from the above letter, it appears necessary to repeat that the air of the house may be renewed at pleasure, by unclosing the apertures which communicate with the drains in which the pipes are laid; that the pipes are readily repaired, when necessary, by opening the covers to the drains; and that the circulation of air produced, so far from being the same as the circulation which takes place by any other mode of heating with hot water that we have seen or heard of, amounts to a positive current, which will set in motion a sheet of paper or a handkerchief suspended from the roof, near the opening from which the hot air issues. In short, the circulation by Mr. Penn's mode of heating is as to the circulation by the ordinary mode, as Perkins's mode of boiling water by a double boiler is to the common mode of boiling.

As some of our readers may have forgotten our description of Perkins's double boiler, we shall here repeat it from the *Gardener's Magazine* for 1832:—

“Suppose we have a common boiler, such as is used in common wash-houses, and in the siphon mode of circulating hot water; then place another boiler within it, of such a size as to leave only a few inches between the inner boiler and the outer boiler all round, and support it in this position by stays, as shown in *fig. 43*: let this inner boiler have a hole in its bottom, about one third of its diameter, and let its rim be 2 in. below the level of the water to be heated. These arrangements being made, and the heat applied below, a circulation instantly takes place and continues; the water coming into contact with the heated bottom and sides of the outer boiler rising rapidly to the surface and descending through the inner boiler, which thus necessarily contains the coldest portion of the liquid.” (*Gard. Mag.*, vol. viii. p. 28.)

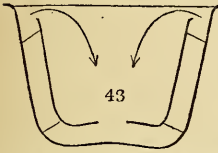

Supposing Mr. Penn's mode of ventilating had no other advantages whatever than that of producing a feeling of comparative coolness in stoves, and setting the fruit in forcing-houses, we should prefer it to all others on these accounts alone. — *Cond.*

Mr. Main's Theory of Vegetable Development.—I feel gratified by the flattering manner in which my essay was noticed by Mr. Main in p. 278. It was necessary to take notice of his theory, because it had been brought forward by Mr. Towers in support of his belief, that no greater vigour was to be expected from varieties of the potato recently from the seed. I think Mr. Towers's inference correct, that if all the parts of a plant are contained in the original embryo, and if even the seed itself is only a further development of that embryo, then all that can ever be produced from a plant is created at its first existence, and we have no grounds to expect benefit from seedlings; but my experience in the greater vigour of varieties of other plants recently from the seed, and seeing the infinite number of varieties and hybrids produced from seed, have led me to adopt a different opinion. In our researches into the operations of nature, when we fancy we have discovered a law or method by which these operations are guided, we should promulgate it for the guidance of ourselves and others; but, unless we can give demonstrative proof of our opinion, it must still be subject to the inferences drawn from observation; and I hope Mr. Main will excuse me, when I say, I have not yet seen any demonstrative proof of the above theory. The subject of adventicity is involved in mystery; properly speaking, there can be no adventitious buds, nothing in nature can be adventitious, all things are the work of infinite wisdom, which cannot act by accident: but, when talking of the operations of infinite wisdom, we are accustomed to call it nature; and, when we see things take place in a manner we have not been accustomed to perceive, we call it unnatural or adventitious. And certainly, I think, when we perceive buds to spring in uncommon quantities, and from places where such quantities could not naturally be expected from former experience, we are warranted in calling these adventitious; and to infer that, here, the theory of a normal quantity previously existing will not so well account for what we observe, as to confess our ignorance of nature's method, and say the vital energy (a power whose actions we cannot define) has organised these buds from the sap. To say they were generated by the vegetable membrane or plate, is only transferring our ignorance to these membranes, and causing them to perform actions which we cannot define or demonstrate; these membranes are themselves organised from the sap, if we are to believe other vegetable physiologists. To say, again, that this vegetable plate or membrane, and all that may be generated from it, originally existed in the embryo; and that it contains innumerable buds and other members which may never be developed, is a *multum in parvo* which is nearly incomprehensible. And when we come to the doctrine of morphology, and find that leaf buds may become flower buds; that it needs only to shorten an imaginary axis, and we have whorls of leaves converted into calyx, corolla, stamens, and pistillum; whether are we to believe that these existed in the

one or the other state in the previous embryo? or by what power are they made convertible? The subject is full of mystery; and, perhaps, as in the animal, so also in the vegetable physiology, to call these the actions of a vital energy we are unable to define is all the length we can yet go, and that all our theories will be the better of plasticity. Perhaps, either Mr. Towers or I may have extended Mr. Main's opinions farther than he thinks warranted himself, and, if so, I would be glad to have a proper and correct definition of them. Is the vegetable membrane the liber? or, like central points and axis, difficult of comprehension? — *R. Lymburn. Kilmarnock, May 13. 1840.*

Constitutional Changes in Plants by being grown in Climates not natural to them. — Did you notice what Mr. Paxton says in his last magazine (p. 80.) about the corraes which are impregnated and raised from seeds in heat? He seems to think that this treatment would affect the future hardness of plants so raised. I once saved seeds from a cucumber which ripened in the open air, and thought that plants raised from these seeds would prove hardier, as a matter of course. I do not think so now, neither do I think that Mr. Paxton's opinion is right on the other side of the question; but he is perfectly right in giving a candid opinion. Nothing tends more to the advancement of knowledge than that those who can think for themselves should avow their opinions, and not pin their faith to the sleeves of others; opposite opinions are thus brought before the public, who may canvass them till truth is sifted out. I am of opinion, reasoning from analogy and from some practice, that an acorn may be vegetated in a stove or melon bed, and the seedling oak grown there for ten years, and if afterwards it is inured to the open air by degrees, it will prove to be quite as hardy as its parent. Yea, if you could follow up your seedling oak till it produced acorns in the stove, and vegetate these again in heat, keeping the seedlings in constant heat for any length of time, they may be afterwards inured to the open air, and will be found just as hardy as if the mother and grandmother had been raised and grown in the highest latitude peculiar to the species; and that this physiological law holds good in the whole vegetable kingdom, whether hardy plants or otherwise. In thus defending an opinion of mine once hastily expressed in this Magazine, I am sure Mr. Paxton will not be the least offended at it. No one can appreciate Mr. Paxton's useful career better than myself. — *D. Beaton. May 5. 1840.*

ART. VIII. *Queries and Answers.*

ADAPTIVENESS of Trees and Shrubs to Soils. — Permit me to hope to see a few lines from some of your correspondents on the adaptiveness of trees and shrubs (both ornamental and useful) to soils; setting forth, at one view, what would best thrive on clays, on clays with a substratum of blue marl, on Shanklin sand or galt, on freestone, on light soils, on stiff soils, &c. — *E. Upper Seymour Street, May 8. 1839.*

The Coccus on the Larch. — The young larch plantations here, near Melton Mowbray, have been infested by the enclosed pest [a branch of larch infested with *Coccus lárícis*] during the last three summers; and they are now increased to such an alarming extent that we almost despair of saving the trees. Is it the *Coccus lárícis* mentioned in the *Ency. of Gard.* § 6595. as seriously injuring most of the plantations in Britain about the year 1805? [Yes.] Sickly plants of the Scotch pine and the silver fir are also infested by a woolly insect, which I should say is an *Aphis*; however, it is evidently different from the one upon the larch. To apply means for their destruction we fear would be an operation too formidable to encounter. I trust that you, or some of your scientific correspondents, through the medium of your excellent Magazine, will throw a little light on the subject, that we may be able to anticipate their departure in the same mysterious manner as that in which they arrived; and will also inform us whether there is an instance known of larch plantations having been totally destroyed by them. — *F. May 6. 1840.*

The Plant Naras "was growing on little knolls of sand; the bushes were about 4 or 5 feet high, without leaves, and with opposite thorns on the light and dark green striped branches. The fruit has a coriaceous rind, rough with prickles, is twice the size of an orange, or 15 or 18 inches in circumference, and inside it resembles a melon, as to size and as to pulp. I seized a half-ripe one, and sucked it eagerly for the moisture it contained, but it burned my tongue and palate exceedingly, which does not happen when this most valuable fruit is ripe; it has then a luscious subacid taste. Some plants of naras are growing in England (March, 1838) from seeds which I brought home; they are 1 ft. high, and beginning to branch, having two thorns at each articulation, and a stipule, scarcely to be called a leaf, between them, on the axis of which is the bud, but no leaves." The above passage is quoted by the *Literary Gazette* from Alexander's *Expedition of Discovery into Southern Africa*. Can you give any additional information about the plant alluded to?
— J. B. W.

ART. IX. *Contributions towards a Life of Lancelot Brown, Esq., the celebrated Landscape-Gardener, and Thomas Whately, Esq., the Author of "Observations on Modern Gardening."*

IN the *Correspondence of the Earl of Chatham*, just published in four 8vo volumes, there are several letters to and from Mr. Brown, by which it appears that he was a great favourite of George the Third, much respected by the Duke of Northumberland and various other noblemen, and above all by Lord Cobham, to whom, at Stowe, he was many years gardener. It is hardly possible for any individual to have a higher testimony borne to his character than is contained in some of the following paragraphs:—

The first is a note to a letter from John Calcraft, Esq., to the Earl of Chatham, dated Leeds Abbey, May 17. 1771. The writer, who was just recovering from a severe illness, after thanking Lord and Lady Chatham for their enquiries, says: "Change of air was advised to gain strength, which added to Mr. Brown's¹ summons, who is really exerting himself [to effect some political changes], brought me for two days to the place, which he will much improve."

"¹ Lancelot Brown, Esq., eminent for his taste and skill in laying out gardens and pleasure-grounds, better known by the name of 'Capability Brown,' from his frequent use of that word, in reference to the sites submitted to his arrangement. In the preceding year, he had served the office of high sheriff for the county of Huntingdon, which county his son afterwards represented in parliament. It has been said of him, that he was not only an able artist, but an honest man; for that, on being solicited by the king to improve the grounds at Hampton Court, he declined the hopeless task, out of respect to himself and his profession." (*Correspondence, &c.*, vol. iv. p. 178.)

The next passage is a note to a letter from Mr. Brown to the Earl of Chatham, dated May 3. 1777. We shall first give Mr. Brown's letter.

"My Lord, In a conversation I have lately had [with the king], I was heard with attention. I went as far as I durst upon such tender ground. My reason for troubling your Lordship with this, is owing to a conversation I had with the Duke of Northumberland. I told his Grace the state of your Lordship's health; on which he told me he would immediately wait on your Lordship. When he comes I hope your Lordship will be well enough to see his Grace: no man more truly devoted to your Lordship's interest than he is. There was a meeting yesterday amongst the Lords Rockingham, Camden, Shelburne, Grafton, Abingdon, Craven, &c. — *Lancelot Brown.*"²

"² 'Capability Brown.' This worthy character came into the service of Lady Chatham's father when a boy, in 1737, and rose by his merit to be head gardener at Stowe, in which capacity he continued till 1750, when, at

the recommendation of Lord Cobham, George the Second appointed him to the same situation at Hampton Court and Windsor. He died in 1783. The following pleasant passage is from a letter, written by Lord Chatham to Lady Stanhope: — ‘ I will not fail to obey your Ladyship’s commands by writing to Mr. Brown. I do so with particular pleasure, persuaded that you cannot take any other advice so intelligent or more honest. The chapter of my friend’s dignity must not be omitted. He writes Lancelot Brown, Esq., *en titre d’office*. Please to consider, he shares the private hours of — [the king]; dines familiarly with his neighbour of Sion [the Duke of Northumberland], and sits down at the tables of all the house of Lords, &c. To be serious, madam, he is deserving the regard shown to him, for I know him, upon very long acquaintance, to be an honest man, and of sentiments much above his birth. As he lives at Hampton Court, and has many calls upon his time, he may not be at liberty.’” (*Chatham Correspondence*, vol. iv. p. 430.)

The following note to a letter from John Calcraft, Esq., to the Earl of Chatham, is dated Sackville Street, January 22. 1771. It is extremely interesting, as showing that Mr. Whately was appointed to a situation somewhat analogous to his taste, and as fixing the year of Mr. Whately’s death. The passage in Mr. Calcraft’s letter, to which the note is appended, is as follows: — “ Bathurst is chancellor, De Grey is chief justice of the common pleas, Thurlow attorney-general, Mr. Wedderburn solicitor-general and queen’s chancellor. Good Mr. Whately¹, for his services, has the choice either of board of trade or green-cloth.”

“¹ Thomas Whateley, Esq., at this time under secretary to Lord Suffolk, and member for Castle Rising. He had held the office of secretary to the Treasury, during Mr. Grenville’s administration, and was that gentleman’s private secretary when he was one of the secretaries of state, at which time Sir Philip Francis [author of the *Letters of Junius*] held a situation in the same office under Lord Egremont: ‘ this contiguity of station,’ observes the author of *Junius* identified, ‘ affording him frequent opportunities of acquiring all that intimate and oracular knowledge of Mr. Whately,’ which is evinced in the following extract from *Junius*: — ‘ This poor man, with the talents of an attorney, sets up for an ambassador, and with the agility of Colonel Boudens, undertakes to be a courier. Indeed, Tom! you have betrayed yourself too soon. Mr. Grenville, your friend, your patron, your benefactor, who raised you from a depth, compared to which even Bradshaw’s family stands on an eminence, was hardly cold in his grave, when you solicited the office of go-between to Lord North. You could not, in my eyes, be more contemptible, though you were convicted (as I dare say you might be) of having constantly betrayed him in his lifetime. Since I know your employment, be assured I shall watch you attentively. Every journey you take, every message you carry, shall be immediately laid before the public. Tom Whately, take care of yourself.’ (Vol. iii. p. 310.) Mr. Whately was the author of two pamphlets in defence of Mr. Grenville’s financial measures, and also of an ingenious work, entitled *An Essay on Design in Gardening*.” [This is a mistake; the essay alluded to is by Mr. George Mason. Mr. Whately was the author of *Observations on Modern Gardening*, the first and the best of all the works on landscape-gardening that have ever appeared.] “ In January, 1772, he was made keeper of the king’s private roads, gates, and bridges, and conductor of his person in all royal progresses, and died in the June following.” (*Chatham Correspondence*, vol. iv. p. 75.)

In the notes to these Letters, the excellent taste of the Earl of Chatham in laying out grounds is repeatedly mentioned, more particularly by Bishop Warburton. The places on which he exercised his taste are the South Lodge on Enfield Chase, noticed in our preceding volume, p. 513., and Hayes in Kent, noticed in one of our earlier volumes as being the place where *Brugmansia sanguinea* was first raised from seed.

THE

GARDENER'S MAGAZINE,

JULY, 1840.

ORIGINAL COMMUNICATIONS.

ART. I. *Notes on some Country Seats and Gardens in Lincolnshire, Staffordshire, and Middlesex, visited in May, 1840.* By the CONDUCTOR.

HARLAXTON MANOR. — *May 20.* We had heard much of this place from various architects and amateurs for several years; and an accidental circumstance having brought us in communication with its proprietor, Gregory Gregory, Esq., that gentleman kindly acceded to our wish to see the works going forward on the new site chosen by him for the family residence. Mr. Gregory resides at Hungerton Hall, about five miles from Grantham, and his building and gardening operations are carrying on in a striking situation on the side of a hill, between Hungerton and Grantham, near the ancient village of Harlaxton, as well as in that village. The improvements consist of the erection of a large mansion in the style of James I., the laying out of gardens around it in the geometric style, and the picturesque decoration of the village. As Mr. Gregory superintends every part of these improvements very much himself, both as respects the design and detail, he has been obliged to confine the admission to these works, during their progress, to his own immediate acquaintance; both for the comfort of his own privacy, and on account of the disadvantages that would arise from the interruption of successive visitors.

The parish of Harlaxton would appear to have been the residence of wealthy persons at a very early period. Had there been no other circumstances to prove this, that of an ancient manorial dwelling, called the Manor House, now existing in the village in a state of great dilapidation, although partially inhabited by persons placed there to take care of it, would have been sufficient. It seems to have been a part of a mass of property in this neighbourhood which has frequently been a portion of the jointures of queens of England; and the great natural fertility of the lands around this old mansion, with copious springs of water under its foundations, are additional attestations of its early selection as an abode for persons of wealth.

Antiquarians have mostly united in the notion that it is one of the few remaining early houses of importance that were built apart from towns: they assign it to the period of Richard II., judging from the tracery and forms of the windows, &c.; and this conjecture is in some degree confirmed by some ancient monuments in the church, of a style coeval with that reign.

The grandfather of the present proprietor married the heiress of a branch of the noble family of De Ligne, subsequently to its alliance with that of the Dukes d'Arenberg. Our readers will remember that it was the celebrated Prince de Ligne, chief of this family, who was so conspicuous in the leading royal courts of Europe, at the close of the last century, from his sparkling wit and talents; and that he, owing to his extensive travels, was the first who was enabled to publish a general view of the style, feeling, and taste of gardens throughout Europe, and who created those of his own family seat at Belœil, in Hainault, which are mentioned in the poem of *Les Jardins* by De Lille: —

“Belœil tout à la fois magnifique et champêtre.”

Harlaxton was purchased at the end of the fifteenth century by a younger branch of this family, who, having embraced the reformed religion, came to England to avoid the persecutions of the Duke of Alva, in the time of Philip of Spain. They brought with them great wealth, and made those alterations in the mansion-house which are of the period of James I., and contribute so much to give it the present striking appearance. The family portraits, and the arms of the family in stained glass, with a pedigree written in the French language of the day, are still preserved in the house. It is an interesting family record, showing how many of this house have been knights of the Golden Fleece, and borne many important charges of government, both civil and military, during so long a period in the annals of the Low Countries and the empire.

The parish of Harlaxton, being remote from any public road, has been scarcely at all noticed in topographical works, and there is no county history. As a proof of this, it may be observed, that, notwithstanding the great taste which has prevailed for a number of years past for publications containing engravings of manorial buildings, the unique specimen of Harlaxton Manor-House has not, as far as we know, been either described or engraved. This manor-house is situated in the bottom of a rich valley, close by a small rill of fine water. It is a single house, the hall extending lengthwise, and occupying the whole breadth of the building; while the principal rooms, which extend crosswise, are increased in size by projections of considerable depth, which being carried up, and terminating in gable ends, break the line of roof; and, combined with smaller

projections and gable ends, ancient chimney tops, &c., give the whole a very picturesque and venerable appearance. The entrance is through an arched gateway, of the form and character of the time of James I., into an outer grass court, surrounded by a raised terrace-walk of earth, in which grow large trees, which, branching close to the grass (as Mr. Gregory does not allow this court to have cattle turned into it for grazing), give to the building an umbrageous and retired character, and one in harmony with its venerable colour and antiquity. Immediately opposite is the entrance to the second court, through a gateway formed by pilasters of stone, bearing lions supporting the escutcheons of the family arms, and a screen of arcaded masonry 7 ft. high, of very beautiful design and delicate workmanship. Through this inner court there is a broad pavement of stone which leads to the porch of the house, over which is a rich entablature of masonry, bearing the family arms of De Ligne. A gallery of 90 ft. long on one side, and offices to the same extent on the other, both of which have fallen down, reached from the present house to the screen described, and formed the inner court.

On the south front is a garden surrounded by a moat, with remains of yew hedges and grass slopes, and also presenting some interesting architecture of the date of the reign mentioned. It is upwards of sixty years since the house was inhabited by any of the family.

Part of the interior of the house is evidently of great antiquity. The hall, which contains a raised floor, or dais, at one end, is hung with old armour, arms, family portraits, and various other objects. There is a large wooden staircase, with turned balusters and carved pendants, &c.; and the walls of the two principal apartments are covered with tapestry, and still contain antique furniture, pictures, &c.

Mr. Gregory, having determined to build a new family mansion, informs us that he studied the subject for several years previous to commencing it. He visited almost every part of Europe, and part of Asia; and, having determined to adopt the style of James I., and there being, at the time he commenced, in 1822, few or no books on the subject, he examined personally most of the houses in Britain in that style, or bearing a close analogy to it. Among those which he visited, it may be useful to others to mention the following:—Berkshire: Bramshill, Littlecote. Cheshire: Brereton. Derbyshire: Hardwick. Herts: Hatfield. Kent: Knowle, Cobham. Northamptonshire: Burghley House, Castle Ashby, Dean, Rashton, Kirby, Apthorpe. Nottinghamshire: Wollaton. Suffolk: Blickling. Sussex: Cowdray. Wiltshire: Longleat. Worcestershire: Westwood. Yorkshire: Temple Newsham. Besides these, Mr. Gregory

visited a great variety of smaller manor-houses; and he also found that the buildings of the two universities exhibited much of domestic purpose in style and character.

It is only by the contemplation of a variety of buildings of the kind or period intended to be imitated, that the mind of an architect can become sufficiently imbued with the feelings and views which dictated their erection, to enable him to adopt any given style with a certainty of success. The architects of the time of James I. appeared to have aimed at giving a certain degree of stateliness and magnificence to their buildings by the large scale on which every part of them was designed. The dark shadows consequent upon their projecting parts, and the character of their windows, which are large and frequent, pierce the general mass just to a sufficient extent to deprive it of the monumental character, and to communicate to it the necessary one of domestic purpose and habitation. A beau ideal being thus imagined for the general effect, the details are easily made out; either by copying precedents, or by devising original compositions from the data afforded by existing buildings, or engravings of those which have been destroyed. To embody Mr. Gregory's ideas in such detail as to fit them for the practical builder, he employed Mr. Salvin, whose talents as an architect are well known, and whose designs for the new manor-house at Harlaxton have, with a few alterations, been adopted and acted on.

The principal features of the view are: Belvoir Castle, seen over a considerable tract of woodland; and the churches of Harlaxton, Denton and Grantham, and Bottesford, which last is seen as the terminal object from the entrance-door of the house, and to obtain which the situation of the house was in a slight degree adapted. Two opposite hills terminate abruptly on the right and left, which let in a view of the Vale of Belvoir, which is so flat as, in weather ever so slightly indistinct, to assume the azure hue of sea. The grounds immediately under the house undulate agreeably, and are thrown into park and forest scenery. The view is one of great pastoral beauty and cheerfulness, and well adapted to habitation.

The main body of the house is quadrangular, and it is placed on the only true principle for the climate of Britain; viz. that of having an imaginary line from north to south to form the diagonal of a square. The main approach will be straight, and very nearly a mile in length. From the public road it first gradually descends more than half its length to the bottom of a valley, in which a lake of great extent might readily be formed; and then it as gradually ascends to the court of honour in front of the mansion. It is in Mr. Gregory's plans to place the kitchen-garden and stables on this approach, both with a view to their convenience, and the character of domestic purpose which he is

desirous to carry out throughout. They will be composed and built in the style of the mansion, and the offensive parts of their respective establishments will be concealed, whilst they will contribute to the interest of the approach, and serve to augment the scale of importance of a country residence.

The court of honour will be entered through a gate-house. To the left there will be a *porte cochère* leading to the court of offices; to the right, a broad flight of steps, already formed, leading to the terraced garden; and, directly in front, the entrance-portal, under the frontispiece peculiar to this style. Within the portal, out of a sub, or stags', or hunting-hall, in the basement, a vaulted corridor leads to a wide open flight of stairs; because, in conformity with the plan of ancient buildings in this style, the ground floor is entirely devoted to the servants' apartments and offices. The flight of stairs leads to a banqueting-hall of large dimensions, which serves also as an entrance communication to the principal rooms; though these have also separate entrances, both for privacy and for servants. It would, however, be a waste of time to attempt describing the house without the aid of a plan. We shall therefore only further notice, that the largest room will be a gallery library, 100 ft. long, 24 ft. wide, and 18 ft. high; one end of which will look into a conservatory, 90 ft. long, and 26 ft. wide. The drawingroom will also have a cross-vista into the conservatory, which will be joined to that seen from the library by a third and fourth on different levels, affording variety of architectural display; the whole forming a considerable extent of garden walk under glass, and including Cape and Australian plants in one part, palms and Scitamîneæ in another, and Orchidæcæ in a third.

Of the different elevations, we can only say that they are exquisitely rich and beautiful. The frontispiece over the entrance-portal, the general form of which resembles that at Northumberland House, has rich accompaniments of the inscription and date of building, and its founder, in pierced stone, of finer character and dimensions than those of Castle Ashby or Temple Newsham. The elevation of a part of the private family apartments in the drawingroom front is quite an architectural gem. The central bell-tower, and the angular turrets, all roofed with stone, produce ideas of grandeur and durability intensely felt, but not readily to be described. The value of everything, indeed, is enhanced by the substantialness of the materials, and the excellence of the workmanship. In no house whatever can these be surpassed, and in very few are they equalled. A London builder is now employed, Mr. Nowell (who erected the Duke of York's column in Carlton Gardens, as well as all the late additions to Windsor Castle), under the direction of the eminent Scottish architect, Mr. Burn.

The building is, however, closely watched by Mr. Gregory himself, who keeps himself informed of every part of the construction; and who, from entering so completely into both the design and the practical details of execution, may be said to have embodied himself in the edifice, and to live in every feature of it, as a planter may be said to live in every tree that he has planted, and a florist in every flower that he has raised. Mr. Lamb, who accompanied us to Harlaxton, was more struck with this building than he ever was with any other of the kind. He is a great admirer of the style of James I., and he declares Harlaxton new Manor-House to be more original and more completely worked out than any specimen of that style he had before seen.

When this house is completed, the interior arrangements will be found not less admirable than the exterior elevations. In the principal floor there is no space lost in passages, and no part that is not thoroughly lighted, and a great deal of handsome interior scenic effect produced. The drainage; provision for the supply of hot and cold water, of hot air, and of hot-water pipes for heating the conservatories; the arrangements for supplying coals to different floors, for disposing of the bell-wires so as they may be easily repaired, for conveying all the offensive parts of the service of the bed-room floors to an appropriate room in the ground floor without passing through the parallel floors; and various other details of this kind, have been all kept in view and studied when forming the design, and all carefully attended to in the execution.

It may be worth while to notice the mode in which the coals are supplied to, and cinders removed from, the different rooms; because, though it cannot be copied, except in similar situations, it may be imitated in the case of many large mansions by inclined planes carried up in towers.* The house at Harlaxton

* A great defect in the groups of buildings composing the dwelling-house and domestic offices in the country residences of Britain is, the want of symmetry, either regular or irregular. Regular symmetry, whether bilateral, quadrilateral, or polygonal, can only be given when the house is building; but the effect of irregular symmetry, or picturesque symmetry, as it may be called, can be given to any group of buildings, however scattered, by the addition of a tower which shall rise more or less above the highest part of the general masses. The good effect of such a tower, rising from a straggling group of buildings, is felt by every one who has the slightest taste for landscape composition; and to understand why it has this good effect, it is only necessary to reflect on what symmetry is, and what are its effects. Every symmetrical object consists of a centre, or axis, and of sides, and the use of the one side being the repetition of the other is merely to assist the eye in recognising the composition as a whole, which in regular symmetry it very readily does. When the one side is not a repetition of the other, a whole can only be recognised in the composition by the discovery of the centre, or axis; which being done, the spectator imagines the sides to be

being situated on the side of a steep hill, that part of the offices containing the coals is to be on a level with the upper floor of the house; and from this coal-house to each floor railways within the house will be formed, along which the coal will be conveyed in small railway carriages, and dropped in suitable places of deposit, whence they can be taken as wanted for the service of every floor. We have noticed in Vol. XV. p. 449., that the same result has been accomplished at Bridge Hill. We may add that, in the general conservatory at Chatsworth, all the coal will be supplied to the fireplaces, and all the ashes removed thence, in small iron carriages on underground railroads, such as are used in coal mines.

The conveyance of what are called slops, from the bedrooms to the underground drains, by pipes from a housemaid's closet on each floor, has long been practised; but conveying down linen to be washed is, as far as we know, confined to public hospitals and infirmaries. All that is necessary for this purpose is an upright tube from a housemaid's room, on the ground floor, to the upper floor of the house, which shall pass through the side of a room or closet on each floor. The rest is obvious. The same tube might easily, if necessary, be so contrived as to bring up clean linen, or any other article required by the housemaid. The mode in which this may be done is exemplified in the "rising cupboards" of several coffee-houses in London. (See *Encyclopædia of Cottage Architecture*, p. 696.)

The bell-wires are arranged in the manner described in the work referred to, p. 917. Every part of the building is fire-proof; all the flues may be cleaned without climbing-boys, and all the main drains are sufficiently large to admit of a man walking in them.

The terraced gardens will be on seven different levels, communicating by flights of steps, ornamented with vases, figures,

arranged round it in some suitable manner, though he may not clearly see it. Now, in all irregular piles having a high tower, this axis is seen at once. Hence the great use of towers in point of effect, and they may always be rendered useful; sometimes, when small, as clock or bell towers; when large, as staircases or inclined planes, communicating with other parts of the building; sometimes as prospect towers, as summer sleeping-rooms for servants, as fire-proof rooms for valuable papers, &c. The axis of symmetry at Harlaxton is the bell-tower, directly over the frontispiece, which is the first object that attracts the notice of the distant spectator, and from which his eye is led downwards, and to the right and left; while the masses first, and the leading details afterwards, are gradually recognised, and ultimately, as he advances along the approach, the whole entrance-front develops itself in all its majesty and beauty. No house or other building, and even no landscape or other view, can ever produce a striking effect on the spectator when seen for the first time, in which the axis of symmetry is not a leading feature. The reason is, — without the conspicuous presence of this axis, the view cannot so readily be recognised as a whole.

and numerous other suitable objects; and, in appropriate places, there will be canals, basins, and fountains, summer-houses, shrubs clipped into artificial forms, &c. The upper terrace will be 150 ft. higher than the house, and will form a winding plateau, extending along the ridge of the hill on which the house stands, and commanding, on one side, a very rich view over a fine agricultural and wooded district, and, on the other, the mountains of Derbyshire, forty miles distant. The two extremities of the terrace-gardens will gradually be united to broad walks on the same levels as the terraces, in extensive woods already existing. After these walks have been continued to a certain length on the same level as the terraces, the upper one will gradually descend, and the lower one gradually rise, till, at a considerable distance from the house, they will form, by gentle inclined planes, communications with every level of walk or terrace. At least, the situation admits of this kind of arrangement, as well as of several others.

One thing is however certain, that Mr. Gregory will create what may be called an atmosphere of highly artificial garden scenery in the geometric style, round and overhañging the mansion; and that he will gradually unite it, not with modern shrubbery walks, but with the picturesque woods already existing, harmonising these woods with the artificial scenery by the introduction of foreign plants. For ornamenting the geometric garden, Mr. Gregory possesses an ample stock of vases, statues, and other sculptural ornaments, and of rich gates, and other iron work, collected by him on all parts of the Continent, soon after the peace of 1815.

In the natural woods at Harlaxton, Mr. Gregory has introduced masses of rhododendrons, holly, periwinkle, tutsan, laurel, and other evergreen shrubs; and a great many sorts of herbaceous plants, including bulbs and Californian annuals. One interesting circumstance we cannot avoid mentioning, which is, that when Mr. Gregory was travelling in the Caucasus, and also in the Crimea, he saw the *Heracleum* gigantèum, and thinking it a very suitable plant for the Harlaxton woods, and not knowing that it was already introduced into England, he had a young plant taken up, planted in a box, and sent from Constantinople to England. This plant has left a numerous progeny, which are now luxuriating in a favourite spot called the Cimetière, in the woods at Harlaxton.

The terrace gardens at Harlaxton, though only commenced, already afford some valuable hints to the landscape-gardener. Among these is the good effect of having terraced platforms above the eye, as well as under it. The flights of steps which lead to those above the eye form an invitation to ascend, which the visiter is most anxious to accept, since he cannot be aware of

what he is to see. In this respect, in the geometric style, equally as well as in the natural style, the artist "surprises, varies, and conceals the bounds;" and in effecting this in the ancient style, there is this advantage, that less space is required than in the modern manner. The various directions of the terraces, and the different inclinations of their slopes, produce an effect of light and shade continually varying; and this even, to a certain extent at least, when the sun does not shine, from the reflection of indirect light to the human eye. This effect will be farther heightened by covering some of the slopes with evergreen shrubs kept low, such as creeping savin (much used in terraced gardens in the time of James I.), common juniper, box, &c.; or by trailers, such as ivy, periwinkle; or creepers, such as tutsan; or suffruticose plants and undershrubs, such as evergreen iberis, thyme, hyssop, &c.

It is clear from the example of Harlaxton, that, to carry out the ancient style of gardening to its fullest extent, the side or sides of a hill are essential as groundwork; and that part of the hill must be above the house, and part below it. The intended form which the gardens at Harlaxton are ultimately to assume is exhibited in a model of clay, and all the underground drains, and most of the foundations of the parapet walls, steps, pedestals for statues, summer-houses, &c., are already made.

The Village of Harlaxton is, if possible, more interesting to us than even the new mansion and gardens. We have seen many ornamented villages, both at home and abroad, but none so original, and so much to our taste, as this of Mr. Gregory's. Some of old date are too like rows of street houses, such as those of Newnham Courtenay near Oxford, and Harewood near Leeds; others are too affectedly varied and picturesque, such as that at Blaize Castle, near Bristol; and some have the houses bedaubed with ornaments that have not sufficient relation to use, as when rosettes and sculptures are stuck on the walls, instead of applying facings to the windows, porches to the doors, and characteristic shafts to the chimney tops. We recollect one near Warsaw, which is a repetition of the Grecian temple, with a portico at each end; and one at Peckra, near Moscow, every opening in which has a pediment over it, with highly enriched barge-boards. In some villages, the attempt is made to ornament every house by trelliswork round the doors and windows, which produces great sameness of appearance, and if ornamental, is so at the expense of comfort; the creepers, by which the trelliswork is covered, darkening the rooms, and encouraging insects; while, in other villages, the cottages are so low and so small, that it is obvious to a passing spectator they cannot contain a single wholesome room. However, though we find fault with villages ornamented in these ways, we are still glad to see them; because

any kind of alteration in the dwellings and gardens of country labourers can hardly fail to be an improvement, both with reference to the occupiers and to the country at large.

The great value of Mr. Gregory's improvements in the village of Harlaxton is, that all the leading features have some kind of relation to use, and are, in fact, to be considered more as parts added to the very plainest cottages, in order to render them complete, than as ornaments put on to render them beautiful. All the cottages were built by Mr. Gregory's predecessor in the plainest possible style, but fortunately substantial and comfortable, and two stories high; some of them single, and some of them double, and almost all of them built of stone some yards back from the street, and surrounded by ample gardens. In improving them, Mr. Gregory would appear to have been guided by the following considerations:—

1. *To bestow the principal expense on the main features, such as the porch, the chimney tops, and the gardens.* Almost all the cottages have porches, some projecting from the walls, and others forming recesses: the latter have sometimes open places like loggias over them; and the former, sometimes roofs in the usual manner, sometimes balconies, and occasionally small rooms with gable-ends, or pavilion roofs, according to the style. The greatest attention has been paid to the chimney tops, which are in some cases of brick, and in others of stone; sometimes of English domestic Gothic, at other times local English, such as those common in the neighbourhood of the Lakes or in Derbyshire, &c.: Italian, French, or Swiss chimney tops of different kinds also occur. The gable ends are finished with crow steps, in the Belgian and Scotch style in some cases, with Gothic parapets in others; and various descriptions of bargeboards are used, wherever the roof projects over the end walls. Porches, cornices of brick or stone, ornamental cornice boards, or stone or wooden brackets, are also introduced in front, as supports or ornaments to the roof. Every garden has been laid out and planted by Mr. Gregory's head gardener; creepers and climbers being introduced in proper places, in such a manner as that no two gardens are planted with the same climbers.

2. *Always to have some architectural feature in or about the garden, as well as on the cottage.* For example; almost every garden here has its draw-well, and each of these wells is rendered architectural, and ornamented in a different way. All the wells are surrounded by parapets, either circular, square, of open-work, or solid. Some are covered with roofs supported by carpentry; others with roofs supported by stones, round or square; some are in the form of stone cupolas: in some, the water is raised by buckets suspended from a picturesque architectural appendage; in others, it is raised by pumps attached to

wooden framework of most original construction, massive and architectural; and so on. All the gardens are of course separated from the street by a fence, and there are not two of these fences in the village exactly alike. Some are hedges rising from the inside of dwarf walls; some are walls like those of sunk fences, the garden in the inside being of the height of the top of the wall, which is covered in some cases with a plain stone coping, in others with a brick coping; in some with a stone coping in the Gothic manner, in others with an Elizabethan coping; in some with a parapet of openwork, in others with stone or brick piers for supporting horizontal bars of wood for creepers, as in Italy; or without being connected by bars of wood, but terminating in rough earthenware jars for flowers. Each front wall must, of course, have a gateway to enter to the garden and the cottage, and no two of these gateways throughout the village are alike. Some are wickets between wooden posts, others Gothic or Elizabethan gates between stone piers, square or round; some are close gates, in the manner of many in Switzerland, in others the gates are under arches, some of which are pointed, and others round-headed; some have pediments over the arches, others horizontal high-raised copings, as in the neighbourhood of Naples; and some have small wooden roofs or canopies after the manner of the gateways to the country houses in the neighbourhood of Dantzic. The gateways, in short, afford great variety of character. Besides the front boundaries of the gardens, there are the side boundaries, which are also varied, partly in a similar manner, and partly differently. In some cases, the boundary, though sufficiently well known to the occupants, does not appear at all to the stranger; in others it is of holly, of box, of laurel, of thorn, of flowering shrubs, of fruit trees, or of a mixture of several or all of these, with or without architectural piers, bee-houses, arbours, covered seats, tool-sheds, or other appendages. The gardens, it may be observed, are all laid out differently. In some, the main walk from the street gate to the porch is of flagstone, in others it is paved with small stones; in some with wood, in others with brick; in some with gravel, and in others with broken stone. It is edged with box, with thyme, with ivy, with a broad belt of turf, with a raised edging of stone, or with a flat belt of brick, and sometimes even with wood. The gardens are variously planted, and in some there are very properly trees and shrubs clipped into artificial shapes; two spruce firs form very handsome balls.

3. *Never to employ two styles or manners of architecture in the same cottage, or at all events not to do this so frequently as to lead a stranger to suppose that it has been done through ignorance.* We omit what may be said on the necessity of keeping the recognised eras of the Gothic distinct, as well as the Eliza-

bethan, Swiss, Italian, &c., as sufficiently obvious. In every cottage and its accompaniments, the appearance of one system of construction should prevail, as well as one prevailing direction in the lines of the masses. For example, in a Swiss cottage, with its far projecting eaves and its surrounding balcony, horizontal masses, lines, and shadows are decidedly prevalent; and, beyond a certain point required for contrast, it is not desirable to introduce any vertical masses, lines, or shadows. The windows, therefore, in such a house, should be broad rather than high; and, as those of the ground floor are protected from the weather by the balcony, and those of the upper floor by the projecting eaves, the very simplest form of dressings to the doors and windows is all that is required. To surround them with rich dressings, or protect them by cornices or pediments, such as indicate the purpose of throwing off the rain, or casting a shade on the glass, would be in bad taste, because it would be superfluous, or working for an end that could not be attained; it would, in fact, be counteracting nature, and setting at nought the principles of art; not to speak of weakening the associations connected with style independently of the use of parts.

4. *Not altogether to omit objects purely ornamental, where they can be introduced with propriety.* There is no reason why a cottage garden should not have its sculptural ornaments as well as the garden of a palace; and it is quite reasonable that in both cases the occupant should endeavour to get the best ornaments he can afford. Formerly, the doctrine used to be, that the dwelling of the cottager ought to be low, in order to be expressive of humility; and void of exterior ornament except creepers and flowers, to express the condition of life, or, in other words, the poverty of the inhabitant. But the cottager is now becoming a reading and thinking being; and having a taste for health, comfort, and ornament, in common with other classes of society, he requires higher and better lighted and ventilated rooms; and these, as well as his garden, he will ornament as far as his circumstances will permit. The time has gone by for one class of society to endeavour to mark another with any badge whatever, and therefore we would wish all architects, when designing cottages, to abandon their long-received ideas. "In the construction of cottages, as well as of all other kinds of buildings, great care should be taken that every part should be in its proper character; for nothing can appear more absurd or out of place, than to see mouldings or ornaments, which belong to the regular styles of architecture, introduced in a cottage." This was published in 1805, in a work on labourers' cottages, by an architect of eminence; but in 1840, in the recently improved cottages throughout the country, we see the "mouldings and ornaments which belong to the regular styles of architecture" as carefully applied

as in larger dwellings; and, fortunately, vases of the most elegant forms are so cheap, that no cottage parapet, seat, or bee-house, need be without them. What is most offensive to taste, both in the gardens of the wealthy and of the poor, is the misplacing of sculptural monuments. In Harlaxton village there are sundials and vases, of different forms and kinds, most judiciously placed; for example, as terminations to piers to gates, or along parapets on piers or other preparations, on the piers at the ends of stone seats, &c. In how many instances, not only in cottage gardens and on cottages, but in the gardens and on the buildings of the wealthy classes, do we not see vases set down where they have no legitimate right to be placed whatever; in places from which they might be removed without ever being missed, or without any derangement to the scene in which they were put, but of which, in an artistical sense, they formed no part. Some of the situations proper for vases are: where the vase forms a termination to an object, as to a pillar of a gate, a pier or pilaster in a wall, or a detached column, &c.; where lines of walks or of walls join, meet, or intersect, as in the centre of a system of beds for flowers, or at the angles made by the junction of walks in a pleasure-ground; where niches in buildings, or gravelled or other recesses along walks, are prepared for them, &c. In all cases where a vase is put down in a garden, it ought not only to have a base formed of one or more plinths, but a pedestal to raise the vase nearer the eye, and above the surrounding vegetation, as well as to give it dignity of character. No ornament whatever, whether in a garden or on a building, ought ever to be placed in an inconspicuous situation, or in the less noble parts of the grounds or edifice; and no ornament ought to be made use of which is formed of a material of less value and durability than the material or object on or against which it is to be placed. Hence the bad effect of rootwork and rusticwork in many situations in gardens and in verandas, and other additions or accompaniments to brick or stone houses.

5. *To indicate the occupation of the inhabitant, where it can be done.* For example, the smithy, or blacksmith's forge, when properly introduced, can never be mistaken, nor the carpenter's shop. These two village tradesmen require houses, yards, and gardens, peculiarly arranged, and afford fine sources of variety. The shoemaker may have his stall as a projecting appendage, and the tailor his workshop. Some of the cottagers will possess cows, others pigs or rabbits; some pigeons, and all more or less poultry. The provision required to be made for these kinds of live stock affords interesting sources of architectural and picturesque effect; though in small villages a common cow-shed, as well as a common bakelhouse, wash-house, and drying ground, is frequently found preferable. The house of the schoolmaster

adjoining the village-school, and the house of the clergyman near the church, will always be principal objects; and shops for the sale of different articles speak by their windows. Every large village ought to have an open shed, or other public building, in a central situation, to serve as a kind of market or gossiping place, and also as a playground, or place of amusement, for the boys in rainy weather.

Whoever intends to ornament and improve a village, we would strongly recommend to study Harlaxton. It is impossible to reflect on that village without imagining what a continued scene of ornament and appearance of comfort all England, and even all Europe, would present, if proprietors would follow the example of Mr. Gregory. Happily, in this country, many have been engaged in this work for a number of years, and considerable progress has certainly been made. Though the best mode to succeed is to have the very best advice at the commencement, and submit every elevation that is to be carried into effect to an architect of taste, yet let those who do not value advice of this kind make the attempt with what knowledge they have, or can derive from books, or from observing what has been done by others, and they cannot fail to do good to a considerable extent. The way to insure artistical buildings throughout the country is, not so much here and there to employ a first-rate architect, who may erect a splendid mansion with a handsome cottage as an entrance-lodge, as to create a demand for architectural taste and knowledge among country builders, carpenters, masons, and bricklayers, generally, since it is by these persons that the great majority of country buildings are both designed and executed. It is not by the occasional employment of a first-rate physician that an individual preserves his health, but by having some knowledge of the human constitution himself, and having recourse, when necessary, to the nearest apothecary or village practitioner. Where would be all the beautiful flowers that now adorn the cottage gardens throughout England, if their culture were only known to first-rate gardeners? For the general improvement of cottages, therefore, we must not depend solely on first-rate architects; we must educate the eye of the country carpenter and mason, and give the cottager himself a taste for architectural and gardenesque beauty.

Hungerton Hall, the present residence of Mr. Gregory, Chatsworth, Wootton Lodge, Alton Towers, Trentham, Haringay, Trent Park, Beech Hill, and some places in Middlesex, as well as East Comb, Charlton House, Belford, and Belvidere, in Kent, we shall notice in our Number for September.

ART. II. *Botanical, Floricultural, and Arboricultural Notices of the Kinds of Plants newly introduced into British Gardens and Plantations, or which have been originated in them; together with additional Information respecting Plants (whether old or new) already in Cultivation: the whole intended to serve as a perpetual Supplement to the "Encyclopædia of Plants," the "Hortus Britannicus," the "Hortus Lignosus," and the "Arboretum et Fruticetum Britannicum."*

Curtis's Botanical Magazine; in monthly numbers, each containing seven plates; 3s. 6d. coloured, 3s. plain. Edited by Sir William Jackson Hooker, LL.D., &c., Professor of Botany in the University of Glasgow

Edwards's Botanical Register; in monthly numbers, new series, each containing six plates; 3s. 6d. coloured, 3s. plain. Edited by Dr. Lindley, Professor of Botany in the University College, London.

Paxton's Magazine of Botany, and Register of Flowering Plants; in monthly numbers; large 8vo; 2s. 6d. each.

The Botanist; in monthly numbers, each containing four plates, with two pages of letterpress; 8vo; large paper, 2s. 6d.; small paper, 1s. 6d. Conducted by B. Maund, Esq., F.L.S., assisted by the Rev. J. S. Henslow, M.A., F.L.S., &c., Professor of Botany in the University of Cambridge.

RANUNCULA^A CÆÆ.

Thalictrum cultratum Wall. A hardy herbaceous plant from the Himalayas, of no beauty. (*B. M. R.*, No. 77., June.)

Malvæcæ.

2014. HIBISCUS [mag. of bot. vii. p. 103.
multifidus Hort. many-parted-leaved 卍 □ or 3 au B.pk Swan River 1837. C 1s Paxt.

A very beautiful plant, with deeply cut leaves, and blue flowers, tinged with pink in the centre. Seeds of it were introduced by Capt. Mangles in 1837, and given by him to Messrs. Henderson, Pine-apple Place, Edgware Road, in whose green-house it blossomed for the first time in August, 1839. "It begins branching within about 6 in. of the roots, and proceeds to the height of 3 or 4 feet, forming a regular bush of conical shape." It is grown in turfy loam, mixed with a very little silver sand, and it is propagated by cuttings, which require care, as they are rather apt to drop off. A few seeds have been ripened, which should be sown on a gentle hot-bed, and the young plants pricked out in the seed leaf. (*Paxt Mag. of Bot.*, June.)

Portulacæcæ.

1447. PORTULACA [31.
Thellusonii Lindl. Mr. Thelluson's □ or 1 su S S. Europe 1839. S p.s.1 Bot. reg. 1840,

Synonyme: *P. grandiflora rotunda* Bot. Reg. 1839, Misc. No. 114.

This splendid annual should be raised on a slight hot-bed; the seeds being sown in pots filled with a mixture of old lime rubbish, and well-rotted dung, or decayed leaf mould, and fully exposed to the sun. It should be kept in a sheltered place; for, although it will grow tolerably well if planted in the open border, the flowers are so delicate, that, in such situations, they are much damaged by the wind and rain." (*Bot. Reg.*, June.)

Rubiæcæ.

378. BOUVA^RRDIA [vii. p. 100.
angustifolia Hort. narrow-leaved 卍 □ or 2 au.s S Mexico 1838. C s.1 Paxt. mag. of bot.

A shrubby green-house plant, with very pretty close bunches of scarlet flowers, with a pale pink centre. The flowers are smaller and closer together than those of *B. triphýlla*, and the leaves are much narrower, yet it will probably prove only a variety of that species. It was raised from seeds received from Mexico, by Mr. Low of the Clapton Nursery, in 1838, and flowered in August and September, 1839. Mr. Paxton recommends growing it in a

green-house in sandy loam, mixed with a little heath mould, or decayed leaves. It is propagated by cuttings of the young wood, with bottom heat, and under a bell glass. (*Part. Mag. of Bot.*, June.)

Dipsacæ.

84. MORINA
longifolia Wall. long-leaved ♀ Δ pr 3 jln R India 1839. S s.l Bot. reg. 1840, 36.

A nearly hardy perennial, requiring a dry situation, and "about the same treatment as *Acanthus mollis*." It should be protected from wet in winter by a hand-glass. "It is increased freely from seeds, and flowers from July till late in autumn. The stem is covered with soft hairs, which, when bruised, emit the smell of a geranium." (*Bot. Reg.*, June.)

Compôsitæ.

Tanacetum longifolium Wall. A "weedy plant from the Himalayas." It grows about 2 ft. high, with light green finely cut leaves, and a rayless head of yellow flowers. (*B. M. R.*, No. 78., June.)

Polemoniæcæ.

Polemonium cæruleum var. *grandifolium* Lindl. An Indian variety of this well-known plant, with flowers three times as large as those of the common kind. It is a biennial. (*B. M. R.*, No. 76., June.)

Labiâtæ.

ORTHOSIPHON Benth. (*Orthos*, straight, *siphon*, a tube; in allusion to the form of the corolla.) incurvus Benth. incurved ♀ ☒ I pr j l Pk Sylhet 1828. S co Bot. 173.

Orthosiphon is one of the genera separated by Mr. Bentham from the old genus *O'cymum*, as *Côleus* is another. The species has pretty pink flowers, disposed in racemes of from 6 in. to 1 ft. long; and it is kept in the stove. It is a native of the hills of Sylhet, and it was sent from the botanic garden at Calcutta, by Dr. Wallich, to the Duke of Northumberland, and it flowered in His Grace's collection at Syon.

Amentæcæ.

Quercus rêgia Lindl. The general appearance of this oak resembles that of a Spanish chestnut. Its leaves are dark green and shining, heart-shaped at the base, and frequently 9 in. long, and 3 in. broad. "The leaf-stalks are almost $\frac{3}{4}$ of an inch long. It probably belongs to the same section of the genus as *Q. rigida*." (*B. M. R.*, No. 73., June.)

Q. Brantii Lindl. Apparently allied to *Q. Ballôta*, but with the leaves 6 in. long, including the petiole, and $3\frac{1}{2}$ in. across the widest part; "they are as downy as those of a young plum tree." This species has been named in honour of Mr. Brant, who discovered it. (*B. M. R.*, No. 74., June.)

Orchidæcæ.

3603. MYANTHUS
spinôsus Hook. spiny ♀ ☒ cu 1 f G.br Brazil 1840. O s.p.l Bot. mag. 3802.

This curious epiphyte was one of the very few found by Mr. Gardner in the interior of Brazil. Its general appearance is somewhat like that of a *Catasetum*, but it is characterised by the singular formation of its labellum, "the margins of which are beautifully fringed with white, flexuose, succulent hairs, greenish white beneath, dotted with red, bearing on the upper side at the base an erect three-partite spine or horn, and having a much larger porrected one below the acumen, which is a little toothed or fimbriated." (*Bot. Mag.*, June.)

2540. ONCIDIUM
Huntianum Hook. Mr. Hunt's ♀ ☒ or 2 o R.v Brazil 1839. O s.p.l Bot. mag. 3806.

A very beautiful species of this extensive genus; nearly allied to *O. carthaginense*, but with smaller flowers, "much more beautifully marked and coloured, and the lip has a totally different structure." (*Bot. Mag.*, June.)

AGANISIA Lindl. (*Aganos*, quiet or desirable; in allusion to the pretty appearance of the plant.) pulchella Lindl. pretty ♀ ☒ pr $\frac{1}{2}$ N.W Demerara 1839. D r.w.p. Bot. rep. 1840, 32.

A pretty orchideous plant, nearly allied to *Maxillaria*. In order to cultivate it "successfully, it should be suspended upon a block of wood from the rafters of the stove, and its thick fleshy roots allowed to hang in the air, and

imbibe its moisture. A damp atmosphere, syringing its roots and leaves freely when in a growing state, and shade during bright sunshine, are the principal requisites in its cultivation. (*Bot. Reg.*, June.) (See *Gard. Mag.*, vol. xv. p. 399.)

2554. EPIDENDRUM
vitellinum Lindl. yolk of egg $\text{E} \square$ sp 1 s O.Y Mexico 1838. D p.r.w Bot. reg. 1840, 35.

A most splendid plant, producing, in its native country, very large orange-yellow flowers, which have a dazzling appearance, not only from their size and colour, but from their great abundance, Dr. Lindley having seen fifteen expanded blossoms on a spike not more than 6 in. in length. It was found in Mexico, at an elevation of 9000 ft. above the level of the sea, and it appears to prefer "a damp, cool, and shady situation." (*Bot. Reg.*, June.)

+ *Epidéndrum (Encyclia) incimbens* Lindl. Very nearly allied to the panicked encyclias. (*B. M. R.*, No. 84., June.)

E. Stamfordianum Lindl. "This plant inhabits only the coast, on shady very moist lands;" and requires nearly the same treatment as the cattleya, but more moisture. (*B. M. R.*, No. 88., June.)

Brasavola glauca Lindl. The flowers are large, white, and very aromatic, and the plant is found on oaks. (*B. M. R.*, No. 89., June.)

+ *Odontoglossum grande* Lindl. A noble plant, the dried flowers of which "measure six inches and a half from the tip of the petals," and look something like those of "an enormous maxillaria." Mr. Skinner thinks the plants of this genus formerly sent home were kept too warm. (*B. M. R.*, No. 94., June.)

2527. LISSOCHLUS 30192 parviflorus *Botanist*, No. 172.

The flowers are green and yellow, striped with reddish brown.

Coryánthes speciosa var. *alba* Lindl. "The appearance of the plant is described as being intermediate between *C. macrantha* and *C. maculata*;" and the flowers are almost white. (*B. M. R.*, No. 75., June.)

Cyrtóchilum maculatum var. *Russellianum* Lindl.; *C. Russelii* Skinner. A fine variety "with very large richly spotted flowers." (*B. M. R.*, No. 86., June.)

+ *Laelia superba* Lindl. The finest species of this beautiful genus. "It flowers in November, and, in some instances, bears from 18 to 20 flowers, on stems from 9 ft. to 12 ft. long." (*B. M. R.*, No. 87., June.)

Iridæcæ.

142. IRIS 30113 deflexa.

The plant figured under this name by Messrs. Knowles and Westcott, in their *Floral Cabinet*, t. 51., has been proved by the Honourable and Rev. W. Herbert to be the same as the *I. nepalensis* *Bot. Reg.* t. 818., *I. Humei* G. Don, *Hort. Brit.* 1236. Mr. Herbert adds that he considers the true name of this *Iris* to be *I. germanica* var. *nepalensis*.

Rigidella flammæa. This new genus was stated by Dr. Lindley, in his previous character of it, to be devoid of petals, or inner segments of the perianth; but he has now discovered "that at the very bottom of the cup formed by the convolution of the three scarlet leaves of the perianth there is a copious secretion of honey, and that, immersed in this substance, are three small rudimentary petals, resembling anthers at first sight." (*B. R. M.*, No. 64., May.)

Amaryllidæcæ.

935. ISMENE 51627 *Knightii* Fl. Cab.

This plant, Dr. Lindley informs us, is the *Hymenocallis rotata* of Loddiges's *Bot. Cab.*, t. 19.; and the *Pancrätium rotatum* of *Bot. Mag.*, t. 827. (*B. M. R.*, No. 55., April.)

Hymenocallis Harrisiana W. Herb. "This species, very unlike any yet known, was imported from Mexico by Thomas Harris, Esq., of the Grove, Kingsbury." (*B. R. M.*, No. 63.)

936. CALOSTEMMA

carneum Lindl. flesh-coloured $\text{E} \triangle$ or 1 ap Pk Australia 1836. O s.pl Bot. reg. 1840, [26.

A very handsome species, with bright pink flowers, which it produced freely

in a pit in the Horticultural Society's Garden; but, as it was found by Major Sir Thomas Mitchell on the summit of a chain of rocky mountains, it will doubtless prove nearly hardy. (*Bot. Reg.*, May.)

3655. STENOME'SSON
latifolium *W. H.* broad-leaved ♂ Δ | or 1 my O Lima 1837. O p.s. I Bot. mag. 3803.

This very beautiful bulbous plant was sent to Spofforth from Lima, in 1838. It requires "a pretty strong alluvial soil, with manure that is perfectly rotten." The leaves grow rapidly when the plant receives moisture, but they will not bear the ardent rays of the sun. "After their decay the pot should be left dry, and the flower-scape will rise while it is yet unwatered." (*Bot. Mag.*, May.)

SPREKĒLIA [p.s. I Bot. reg. 1840, 33.
cybister var. brēvis *W. H.* short-flowered tumbler ♂ Δ | or 1 ... R.G. S. Amer. 1839. O
Synonyme: *Hippeastrum anomalum Lindl.*

Sprekĕlia is the new name given by Mr. Herbert to the *Jacobæa* lily, the old *Amaryllis formosissima*; and he considers this plant, which flowered in Mr. Knight's Exotic Nursery, King's Road, Chelsea, to belong to the same genus. A nearly similar plant, but with longer flowers, has lately flowered at Spofforth, where it was called "the Tumbler, from the very singular precipitation of the buds in their progress towards expansion, and in the final perpendicular position of the lower lip of the flower." (*Bot. Reg.*, June.)

Tulipacææ.

1016. LYLIIUM 30171 eximium *Bot. Gard.* 733.

Commelinacææ.

1000. TRADESCANTIA 31728 iridescens *Bot. Reg.* 1840, 34.

This curious little plant has been already mentioned in the *Gard. Mag.* vol. xv. p. 34. It is stemless, its height is not more than half a foot, and its flowers are of a dingy lilac. "It is a half-hardy perennial, with tuberous roots, growing in any rich soil, and flowering in July and August, each flower only lasting for a few hours. The plant is increased freely by seeds, but seldom flowers before the second season; its roots may be preserved during winter, if kept dry in the pots, or in sand, like Cape bulbs." (*Bot. Reg.*, June.)

+ *Spironema fragrans* Lindl. A new Mexican herbaceous plant, with delicate whitish fragrant flowers. (*B. M. R.*, No. 48., April.)

REVIEWS.

ART. I. *Transactions of the Horticultural Society of London.* 2d Series, Vol. I. Part V. 4to. London, 1833.

(Continued from Vol. XIII. p. 365.)

WE have so long left off reviewing these *Transactions* that our readers may perhaps have supposed that we had forgotten them. This has by no means been the case; we have been obliged to omit them from a pressure of matter, and from the Magazine being smaller in size than it was five or six years ago. In the course of the current year we shall get through the whole of our arrears. We left off with Art. 53., in Vol. I. of the second series, the essence of which will be found in Vol. XIII.

54. is Mr. Thompson's *Journal of Meteorological Observations.*

55. *An Account of some Experiments made in the Garden of the Horticultural Society, with a View to ascertaining the relative Productiveness of the Tubers and Sets of Potatoes.* By Dr. Lindley. Read March 4. 1834.

This is a very valuable paper; partly from the physiological remarks it

contains, and partly because it proves experimentally the superiority of single eyes, as sets, to whole tubers. The experiment was made in the year 1832, in the Horticultural Society's Garden, when five plots of ground of equal size, and as nearly as possible of equal quality, were selected for the growth of five different varieties. One half of each of these plots was planted with whole tubers, and the other with sets containing but one eye each; the plants were 1 ft. apart in the rows, and the rows themselves 18 in. apart. The result in round numbers, and on five acres, is about two tons in favour of single eyes.

The experiment was next tried in a piece of ground in quality as nearly uniform as possible, which was divided into 4 ft. squares. In the centre of each square was planted either a tuber, or a single eye, or a set containing three eyes, or the whole surface of a tuber pared off, so as to leave the eyes safe, but to remove the centre. The result in this case was, in 13 cases in 16 in favour of single eyes as compared with tubers; in 9 cases in 16 in favour of single eyes, as compared with sets containing three eyes; and in 10 cases in 16 in favour of single eyes as compared with parings. Or in the proportion of whole tubers 2; single eyes 11; three eyes 5; and parings 4.

Another experiment for the purpose of ascertaining the same object was tried, in which the rows of tubers were 4 ft. apart instead of 18 in. and the plants 6 in. apart in the rows. Here the tubers had full room to grow, but, notwithstanding this, the produce was in favour of single eyes in 4 cases out of 5.

On these experiments Dr. Lindley observes, that if they can be deemed conclusive, and he can discover no probable source of error, the opinion which has been entertained of the superior productiveness of tubers over sets is unfounded, a conclusion to which Sir George Mackenzie has also come, from experiments made by him in Ross-shire.

56. *On Benthàmia fragífera and the Climate of Mussoree, its native-Country.*
By J. F. Royle, now Professor Royle, of King's College, London. Read May 6. 1834.

This highly ornamental shrub being now in general cultivation in choice collections, we pass on to

57. *Observations and Discoveries connected with the Culture of Melons.* By G. J. Towers, Esq., C.M.H.S. Read December 3. 1833.

From certain experiments which are described, Mr. Towers draws the following conclusions:—

“First. That the melon will protrude roots into water, which will ramify therein most abundantly; that they will not rot or become inert in water; and that, so far from the melon plant becoming diseased by this fluid medium, the foliage will remain healthy and in full activity, and the fruit attain to perfect maturity.

“Second. That cuttings of the melon and cucumber plants, also single leaves, will strike speedily and almost with certainty in pure water, and may be removed into soil with safety; in which, if the quality be appropriate, the roots will strike without loss of time. The heat need not exceed 70°, perhaps less would be sufficient. Although leaves will strike root, I am not as yet in possession of facts to prove that germs will be produced from rooted leaves. The melon leaf, in fact, perished; not, however, in consequence of being placed in earth, but because I removed it to another glass vessel, in which there was a weak solution of nitre and camphor; these stimulants appeared to be fatal to the roots in a very short period.

“Third. The water, wherein the young plants produced roots and remained for two or three weeks, continued colourless, clear, and perfectly sweet. It is well known, that, if flowers or small shoots of shrubs be placed in water, a fetid odour is quickly discernible, the fluid becomes foul and tainted. In the

phial containing the rooted and growing plant, although plunged in a bed of leaves, the temperature of which was nearly 75° , no taint or flavour was to be perceived. Thus, the vital principle of the plant either prevented the formation, or caused the absorption, of any offensive matters, and kept the fluid in a state of perfect purity. The expense will be found greatly diminished by those who will give the plan a fair and impartial trial.

“*Note by the Secretary.* With reference to the foregoing paper, it is necessary to remark, that there is nothing absolutely new in the discovery that the melon is a plant of amphibious habits. This has been long known, not only from the Persian practice of growing melons on banks of earth between ditches filled with water, but also from the reports of Mr. Moorcroft upon the floating melon beds in the lakes of the valley of Cashmere. The object of the Council in publishing Mr. Towers's paper is merely to direct attention to this circumstance, by means of the observations of its ingenious author.”

58. *On the Management of Bark Beds.* By Mr. John Jackson. Read February 18. 1834.

“ I have generally had my bark beds to turn and renew only once in twelve or fourteen months, instead of three or four times a year. My plan is to have the bed riddled over when I turn my pit, and I then add as much fresh tan as is requisite ; I further have about a cart-load of fresh tan, that has been well fermented with yeast for about three weeks or a month beforehand ; I generally put from 5 lb. to 10 lb. of yeast into the above cart-load of tan, observing to keep it in a good shed, or any other covered place, till the great fermentation is over, and then I mix it up in a regular manner all over my bark bed : I never tread the bed hard down ; I only level it, and put upon the top of it as much tan dust as I can easily plunge my pines into. Care, however, should be taken that the bed does not heat too strongly at first by the above method ; I have sometimes had the heat stand at 80° of Fahrenheit for fourteen months within the bed, which is a long period, and may seem improbable to any man till he tries the experiment.”

We should be glad to know from Mr. Jackson what first suggested to him the idea of using yeast ; and from any of our chemical readers we should be glad to have the rationale of its mode of action. Every one knows that yeast is chiefly carbonic acid, and that that substance is a powerful promoter of decomposition, because it enters into combination with almost every thing. Does it operate on the tan by carrying on the decomposition farther than takes place without it ?

ART. II. *Illustrations of the Botany and other Branches of the Natural History of the Himalayan Mountains, and of the Flora of Cashmere.* By J. Forbes Royle, M.D., F.R.S., &c., &c. Part XI., supplementary Number. Fol. London, 1840. 20s.

WE have here the concluding Number of a work of which too much can hardly be said in its praise. The quantity of matter and plates offered to the public in this part for 20s. may well excite astonishment. There are first titlepages, dedications, &c. to vols. i. and ii. ; next a preface ; then a table of contents ; then a synoptic table of contents, which, with the alphabetical indexes, the author informs us were prepared by Mrs. Royle ; and they do that lady's industry and knowledge of the subjects treated of very great credit. Next follows the completion of the introduction, including the geological features of the Himalayan Mountains ; the meteorology of the plains and mountains of N. W. India ; on the entomology of the Himalayas and of India, by the Rev. W. F. Hope, F.R.S., &c. ; descriptions of insects figured in the plates, by J. O. Westwood, Esq., F.L.S., &c. ; memoir on the mammalogy of the Himalayas, by W. Ogilby, Esq., M.A. ; list of

birds in the author's collection, &c. ; the continuation of the work from Hemerocallidæ, in p. 389., to Algæ, which terminates in p. 443. The alphabetical indexes are, Greek names of plants and drugs referred to in Persian and Arabian works on *Materia Medica*; list of plants and subjects treated of; fossil plants figured; index of zoological subjects; index of plants and drugs in Arabian and Persian authors on *Materia Medica*; list of plates; and, lastly, alphabetical list of 197 plants which are figured.

The plates in the present Part are, Fossils of the Sub-Himalayan, or Sewalik Hills; *Ericaulon Sollyanum*; *Hordeum Ægiceras*, a cultivated barley; and *Andropogon Calamus aromaticus*, which Dr. Royle considers to be the sweet calanus of the ancients.

Such are the contents of the last Part of this most learned, elaborate, and truly useful work, which must sooner or later find its way into all good libraries, public or private, not only in Britain but in every country.

As the influential part of the population of India will in all probability be the descendants of Britons, it is interesting to examine how far the climate will admit of their adopting the habits and practices of their parent country. The horticulture and floriculture of Britain may be indulged in, more or less, in every part of the world; but the landscape-gardening exhibited in English parks and pleasure-grounds must necessarily be of limited extent, from the difficulty of procuring surfaces of green turf throughout the year. For this reason we have thought it appropriate to select a quotation bearing on this subject:—

“Europeans in India prefer, or indeed only give their horses, the creeping stems and leaves scraped off the ground by the grass-cutter, of that grass, which is known by the name of doob, or doorba, *Cynodon Dactylon Pers. var. indica Hort. Brit.* (the species is a native of England, and is shown in *fig. 44.*), and which flowers nearly all the year, and is fortunately by far the most common in every part of India. In Northern India it is a common practice to form lawns and pastures of moderate extent by planting pieces of the creeping stems of this grass.” (p. 421.)

“The base of the Himalayas is clothed with a dense grass jungle, among which species of *Saccharum* and *Andropogon* are the most conspicuous and the tallest, but, when full grown, necessarily too coarse to serve either for pasture or for hay; they are, therefore, yearly burnt down, after which the young blade springs up, affording excellent pasture for herds of cattle. As we ascend the mountains, tropical forms gradually disappear, and those of temperate regions take their place; while at certain elevations, where the cold of winter is severe, and the temperature of the rainy season equable and moist, at the same time moderately high, we find many species of grasses of tropical genera, perfectly at home, in situations which are, in winter, covered with snow; but, as these elevations have their own peculiar species belonging to European genera which are able to withstand the winter's cold, there is at all times abundant pasture in the neighbourhood of most of the Himalayan villages, and, according to the season of the year, the sheep and cattle are driven to different ranges and elevations. The sward upon these mountains is exactly like, though somewhat more luxuriant than, that met with on the mountains of Scotland or of Wales; and the sheep and cattle fed on them have the fineness and flavour of those fed on grain in the plains of India.” (p. 423.)

It would thus appear that the wealthier inhabitants of India may have country seats resembling those of England in the mountainous regions; and, probably, when the country is intersected by railways, a wealthy citizen of



Calcutta may have a suburban garden there, and a summer residence in Nepal, though distant above 1000 miles.

ART. III. *Icones selectæ Plantarum quas in Prodromo Systematis universalis, ex Herbariis Parisiensibus præsertim ex Lessertiano descripsit Aug. Pyr. DeCandolle.* Editæ a Benj. DeLessert. Academiæ Scientiarum Socio honario, &c. Vol. IV. exhibens Compositas. Figures of select Plants from the Herbariums of Paris, and more especially that of Baron DeLessert, &c. Fol., pp. 52, 100 plates. Paris, 1839.

THIS is the fourth volume of an elaborate scientific work, prepared at the expense of a wealthy amateur, and presented to the principal botanists and public libraries of Europe. It is a useful, elegant, and certain mode of erecting a monument to one's own memory, and we wish we could see it become more fashionable in this country. The volumes are published from time to time: vol. iii. is dated 1837, and contains figures of plants of thirty-one natural orders on one hundred plates. This volume also contains an index of names and synonymes to the engravings in vols. i. and ii., each of which volumes also contains a hundred plates. The engravings in vol. iv. are entirely of *Compôsîtæ*; as in the other volumes, they are in number one hundred. The descriptions occupy forty-four pages; after which is an alphabetical index to the plates in all the four volumes. Throughout the whole work the engravings are most beautifully executed in outline, and the descriptions concise and comprehensive. In every point of view the work is creditable to the artists and the press of France, and to the high intellectual character of her scientific men.

ART. IV. *Instructions in Gardening, for Ladies.* By Mrs. Loudon. 8vo, pp. 406, several wood-cuts. London, 1840.

WE cannot give a better idea of the nature of this most excellent work than by quoting the introduction, which, in every point of view, is quite characteristic of the authoress.

"When I married Mr. Loudon, it is scarcely possible to imagine any person more completely ignorant than I was, of every thing relating to plants and gardening; and, as may be easily imagined, I found every one about me so well acquainted with the subject, that I was soon heartily ashamed of my ignorance. My husband, of course, was quite as anxious to teach me as I was to learn, and it is the result of his instructions that I now (after ten years' experience of their efficacy) wish to make public, for the benefit of others. I do this, because I think books intended for professional gardeners are seldom suitable to the wants of amateurs. It is so very difficult for a person who has been acquainted with a subject all his life, to imagine the state of ignorance in which a person is who knows nothing of it, that adepts often find it impossible to communicate the knowledge they possess. Thus, though it may, at first sight, appear presumptuous in me to attempt to teach an art, of which, for three fourths of my life, I was perfectly ignorant, it is, in fact, that very circumstance which is one of my chief qualifications for the task. Having been a full-grown pupil myself, I know the wants of others in a similar situation; and, having never been satisfied without knowing the reason for every thing I was told to do, I am able to impart these reasons to others. Thus, my readers will be able to judge for themselves, and to adapt their practice to the circumstances in which they may be placed.

“ Such are the nature and purport of the present work ; and I have only to add, that I have spared no pains to render it as perfect as I could make it. The engravings have been made here from drawings of specimens previously prepared, and I can, therefore, vouch for their accuracy. — *Bayswater, May 28, 1840.*”

The work is written in a style at once correct, clear, and adapted to the subject ; for we must do its authoress the justice to say, that, besides having a mind capable of acquiring whatever kind of knowledge she thinks fit to attempt, she is the most complete mistress of English grammar that we know of. That she is equally capable of writing with elegance and poetic feeling, and adapting herself to infancy as well as to mature age, we have only to refer to *Agnes Merton*, and her other works for children, and to the *Mummy*, &c.

That the book which has given rise to these observations will be of singular use to the ladies of this country, and form an era in the history of their happiness, we are thoroughly convinced.* To derive the fullest enjoyment from a love of flowers, it is absolutely necessary to do something towards their culture with our own hands. Labour is at the root of all enjoyment. The fine lady who has a nosegay put on her table every morning by her gardener, has not a tenth of the enjoyment from it that the lady has who has sown the seeds, or struck the cuttings, and watered and shifted, or transplanted, pruned, and tied up, or pegged down or thinned out, the plants, and at last gathered the flowers herself. But we would have ladies of leisure do a great deal more than this. Let them hoe, and rake, and dig, and wheel a barrow, and prune and nail wall-trees, handle a syringe, and work one of Read's garden engines. By these and similar operations, they will insure health, without which there can neither be good temper, nor any kind of enjoyment whatever, mental or corporal.

The grand and all-pervading evil among ladies of independent fortune is *ennui*, which, everybody knows, is brought on from a want of rational and active occupation. Now the pursuits of botany and gardening supply an occupation which is at once rational and active ; and they supply it, not only to the lady who has merely a love of flowers without a scientific knowledge of botany or a taste for the arts of design, and who may, therefore, cultivate her flowers, and perform her garden operations, without a greater exertion of mind than is required for a gardener's labourer ; but to the scientific lady, whose botanical knowledge, like that of the scientific gardener, may enable her to raise many new kinds of flowers, fruits, and culinary vegetables, by the different processes required for that purpose ; and to the lady of artistical taste in drawing, painting, and sculpture, who may direct her attention to landscape-gardening, and, more especially, to the designing of flower-gardens, and the introduction in them of the various kinds of ornaments of which they are susceptible ; a subject at present as much in its infancy as botany was before the time of Linnæus.

But, say some of our readers, “ What ! the Duchess of —— wheeling a barrow, and nailing wall-trees ! ” — Yes, certainly, if she has nothing else to do, that will be an occupation equally rational and active. Why not a duchess, as well as a plain mistress ? Suppose this duchess at work in her garden, and that you are not aware that she has any title. Suppose her dressed in the simplest manner (as were the Vicomte d'Ermenonville's wife and daughters, in the gardens of Ermenonville), what wonder would there be then ? Ladies of rank are as much subject to *ennui*, as ladies without rank ; and every lady, as well as every gentleman, has a portion of the day that she can call her own, when she may indulge in what she likes. If she has not, her life is not worth keeping. Did not the Earl of Chatham, notwithstanding his being prime minister at a period the most important that ever

* One cause of conviction is, the great demand for the work, of which 1350 were sold on the day of publication.

occurred in the annals of this country, find time, not only to lay out his own grounds, but to assist Lord Littleton in laying out Hagley? We insist upon it, therefore, that what we propose is just as suitable and necessary for ladies of the highest rank, as it is for those without rank; provided they are equally without rational and active occupation of some other kind.

ART. V. *The Eastern Arboretum, or Rural Register of all the remarkable Trees, Seats, Gardens, &c., in the County of Norfolk.* By James Grigor. Illustrated by drawings of trees, etched on copper by H. Ninham. No. I. 8vo, pp. 24, 3 plates. London, June, 1840. 1s.

WE have great pleasure in noticing this publication; partly from our regard for the author, and partly from the genuine love which he exhibits for a subject to which we ourselves are so much attached. To give our readers an idea of what this work is intended to be, we shall begin by quoting from the introduction:

“The Eastern Arboretum refers not to the vegetable wonders of the Oriental part of our globe, but to a district of our own peaceful and happy England. This district has long been in the advance of all others in the pursuits of agriculture, and we are anxious to see it excel in the kindred sciences of arboriculture and gardening. In some parts, indeed, as the subsequent pages of this work will show, it may be said already to excel even in those respects; but, generally speaking, the country in this quarter is still susceptible of improvement.

“There is no county in England possessed of a greater variety of soils than Norfolk: it abounds in all descriptions, from the lightest sand to the stiffest clay, so that any thing that lives in our climate will find a soil here congenial to its nature. Its capabilities in this respect are immense. Our elevated waste lands are adapted to the pine and fir tribes; our deep loams, such as abound in the margin of the fen country about Upwell, Wisbech, and no doubt in many other districts, are capable of producing gigantic specimens of our timber trees; and the fens themselves are full of the sort of soil that our American plants delight to grow in. What would be thought of hedges of the *Rhododendron ponticum* growing around our fen dwellings about twenty feet high and in full flower? Such a thing would be thought wonderful and very beautiful, no doubt; yet the wonder is that we do not see it every day of our lives, for it is as natural for this tree to flourish in such soil as it is for the white globe turnip to grow on our well-tilled farms. Our moist land, again, as almost every one knows, is suited to display the beauties of the poplar and willow tribes; and it is much to be regretted that some of our brooks and rivers are suffered to glide over our valleys unattended by such delightful ornaments as those trees invariably form in such situations.

“But the rich and varied resources of our soil will avail us little, if the principle of adaptation be overlooked. Our trees must be planted in soils and situations adapted to their nature, else our labour will be comparatively profitless. This perfect arrangement is every where observable in the economy of vegetation, as seen in nature. In the more striking outlines of this beautiful distribution, even the inexperienced are able to trace the situations and soils which certain vegetables delight to grow in. The willow and the alder, for instance, are naturally associated with rivers and swamps; and it is in such situations only where they are to be seen in all the exuberance of their nature. An aloe, on the other hand, is furnished with thick fleshy leaves which imbibe moisture freely and expend it sparingly, and we find it flourishing in a sandy desert and under a burning sun, where it rains only at long intervals, and where the heavens are seldom darkened. In some countries, the geographical range of temperature, for almost all sorts of trees, is confined

within the compass of a few miles, so that the whole scale of the vegetable creation may be traversed in the course of a day. In Vera Cruz, a province of Mexico, situated under a tropical sun, this fact is most strikingly and beautifully illustrated. At the base of the mountains, and near to the sea-side, the most suffocating heat prevails, and vegetation proceeds as if in a hot-bed. In ascending the mountains, tiers of vegetables rise above one another in admirable order. Nature becoming gradually less luxuriant and the flowers less coloured, till, passing through the zones of liquidambar, banana, Mexican oaks, &c., pine trees only are to be found, and these amid everlasting snows. In our own country, we find the pine tree preferring the loftiest mountains of our land, to which it is indigenous; and one of them, indeed, *P. maritima*, unlike the most of ligneous plants, courts the sea-shore and withstands its blasts. The beech, again, rises in chalky and stony grounds, and flourishes where other trees will not grow; we have seen it in great beauty and perfection even on the debris of rocks of a siliceous character. Such is the adaptation of Nature.

“At the same time, it is experienced by almost every one, that, if any degree of care be taken in planting them, the most of trees, though huddled together, as they often are, without reference to the soils and situations best suited to the various species, will, for a few years, maintain a tolerably healthy appearance, more especially if planted in a sheltered situation; but afterwards they soon begin to fall away: the larch becomes black and unsightly, putting forth a profusion of fruit or cones, — a never-failing sign of its unhealthy state; the spruce fir loses its under branches; the ash and elm cover themselves with moss; and, in fact, every species, except that to which the soil and situation are adapted, betrays some sign of its being misplaced. In this work, therefore, it shall be our object to point out, so far as our experience and observation suggest, the proper soils and exposures for trees generally grown in England, as we are convinced that a knowledge leading to their proper distribution will induce many proprietors to plant tracts of country which have been hitherto considered unfit for forests, and be the means of heightening the beauty of plantations and pleasure-grounds already in existence.

“We have no desire to speak disparagingly of the numerous works already published on the subject of trees. The most of them, so far as we know, contain many useful hints on the work of planting, pruning, &c.; but is it not notorious that, with one or two exceptions, those authors treat the subject in a dull, uninteresting manner, as if a tree were the most uninviting thing in existence, and as if its beautiful fabric, root and branch, were to be valued only in proportion to the extent of flooring, or the number of chairs and tables it would produce? We confess that such information is highly necessary to be known, and any arboricultural treatise would be imperfect without it; but to make those dry statistics the sole theme in a work of this description is disgusting, and accounts perhaps for books of this sort being so much banished from our polite reading. They seem to have forgot that there is poetry in trees, — that they bear much of the history of our country, and that they are loved and venerated by some men as reminiscences of the past.”

After referring to the *Arboretum Britannicum* in terms gratifying to our feelings, the author says: —

“As to our own humble pretensions on the subject, we must allow the present work to speak for us. Out of love to the science, we have devoted an apprenticeship of about twenty years to practical botanical pursuits, so that we are without excuse if we should not throughout be guided by generally ascertained facts.

“It is our intention, then, to notice all the trees of Norfolk that are interesting on account of their age, size, rarity, historical association, or in any other respect; and, in order to make it complete as a book of reference, we shall annex directions as to sowing, transplanting, pruning, and felling all our English timber trees; the whole forming a popular dictionary of every thing relating to this interesting department of Natural History.

“ In order to break the monotony of a continued treatise on the same class of subjects, the reader will be occasionally relieved by general descriptions of such gentlemen's seats as are considered worthy of particular notice ; and as it would be inconvenient and incompatible to treat of trees at length under the head of *Seats*, and *vice versa*, a portion of each number will be devoted to the respective subjects.”

The body of the work now commences with a chapter on “ Trees in General ;” and next follows one on the “ Trees of the City” [of Norwich], which is followed by an article headed, “ Proposed Public Garden in the City of Norwich.” “ That the capital of Norfolk should have been so long without a public garden, cannot be attributed,” Mr. Grigor informs us, “ to a want of taste for flowers among its inhabitants ; for so predominant is this taste, that Norwich is emphatically termed the ‘ City of Gardens,’ or the ‘ City in an Orchard ;’ “ this fact,” he adds, “ gives the surer promise that the project will meet with success ; for it would be almost hopeless to expect that a community not fond of those pursuits would see any merit in an institution devoted to them.” After various arguments in favour of establishing a Botanic Garden, the author makes the following observations, which we quote as being applicable in the case of towns generally :—

“ But, apart from a botanic garden being a scene of beauty and attraction in itself, it would stimulate all our amateurs in the city to procure those ornamental trees and flowers hitherto unknown, or not generally cultivated in this quarter, so that all our gardens around would take their tone from this central emporium of taste. It is especially to be regretted that so little attention is given in this quarter to the introduction of the finer kinds of hardy trees and shrubs. Horticulture and Floriculture have their societies, and are flourishing ; but any effort to introduce new or rare trees — those magnificent and enduring ornaments of nature — has not yet been made. Around Norwich there are consequently but few novelties to interest the botanical cultivator.

“ Of the beautiful and numerous species of the genus *Cratægus*, there are only three generally met with — *C. punctata*, *C. Crus-galli*, and *C. Oxyacantha* with its varieties. Of the like numerous and not less beautiful genus of the *Æsculus* or *Pavia*, there is only the common *Æ. Hippocastanum* ; and, indeed, so general is this want of novelty, that one cannot but wonder how so few of those fine trees, which have been so long in cultivation, have found their way into our gardens. A botanical collection, open to the citizens, would remedy this ; for to see trees is far more persuasive and satisfactory than a picture or description of them, however elaborate. No one scarcely can walk through the gardens of Chiswick, Hackney, Chatsworth, or any old arboretum, without resolving to add to his collection such trees as he does not already possess ; and it is unquestionable, that, if such a stimulus were commenced here, it would soon have the effect of enriching and beautifying our country.”

Mr. Grigor next shows that such a garden “ would enable us to distinguish botanically what trees are best worthy of cultivation for the sake of their timber ;” and here he quotes from the *Quarterly Review*, Sir Walter Scott's story of a bad kind of oak being introduced from the German forests, and propagated extensively in Hampshire and Norfolk, which is known to be, like the same author's story of a kind of Scotch fir imported from Canada, without foundation in fact. It is true, however, that the wood of *Q. pedunculata* is generally considered preferable to that of *Q. sesiliflora* as ship-timber, which is the point Mr. Grigor seeks to establish. (See *Arb. Brit.*, p. 1786. and 2171.)

The author concludes with expressing a hope in which we sincerely concur, “ that the time is not very distant when every town and village shall have its library, scientific institution, museum, and public pleasure-garden, as was proposed in a bill submitted to the House of Commons by Mr. Buckingham ; for we believe that if ever mankind are to be better than they are, it will be through the establishment of the different branches of Natural History throughout the country.”

We cordially recommend Mr. Grigor's work to all our readers, but more especially to those resident in the eastern counties.

ART. VI. *History and Guide for drawing the Acanthus, and every other Description of Ornamental Foliage, by Rule; whereby such Principles and Plans are formed that any Student may become his own Designer, for whatever Purpose he may require.* The whole planned, designed, engraved, and printed by J. Page, Ornamental Draftsman, Atlas Press, Horseferry Road, Westminster. Parts I. and II. pp. 481, 6 wood-cuts. 9d. each.

WE most strongly recommend the young gardener who is anxious to be able to draw by the eye, without rule and compass, to procure these little works, and copy the figures in them with pencil, or with a steel pen and ink. If a gardener could only foresee the immense advantage that it would be to him to be able to sketch freely, and thus communicate his ideas quickly and intelligibly on the spot, he would labour mornings and evenings, for months, nay, for years, if necessary, to acquire so valuable a talent. Every gardener can draw plans by the help of a rule and square; but he that has cultivated the power of sketching objects at sight has elevated himself to a higher region; and if to this faculty is joined a knowledge of grammar and style, elegant penmanship, and good manners, he has acquired all the essentials of a gentleman, and he will be respected by his employers accordingly. There are many things (for example, a knowledge of the principles of horticulture or agriculture) which may be attained after the middle age; but those which we have mentioned, if not acquired in youth, cannot in general be acquired at all. The time is fast approaching when every first-rate head gardener will require to be a good landscape-gardener, and the being able to design a flower-garden in different styles will be considered as necessary for such persons as to design a cucumber frame or a mushroom shed now is. All that is wanting to bring things to this state is, that the rising generation, who are all becoming scientific botanists and horticulturists (thanks to Dr. Lindley more than to any other man living), shall be grown up. And why should those who are capable, as has been proved by the examinations in the Horticultural Society's Garden, of acquiring a high degree of scientific botanical knowledge, while working all the day in the open garden, and only studying in the evenings, not be able under the same circumstances to acquire the art of sketching to a high degree of perfection, and a cultivated taste in forms, lines, and colours? There is no reason why they should not, except this, that hard work with garden tools must greatly injure the hand for sketching; and this, we trust, will be borne in mind by gardeners who take apprentices, and by all who employ young men who are anxious to improve themselves.

ART. VII. *Ricauti's Rustic Architecture.* Parts I. and II. Oblong 4to, 147 plates. London. 6s. each Part.

IN the introduction, the author informs us that he is "quite conscious of adding but little to what has already been advanced on the subject of rural cottages, &c.; but he adds, "if that little be clothed in a somewhat novel form," he hopes to escape criticism.

"The designs herein delineated exhibit no ornament (excepting the chimney shafts) but such as can easily be procured by a judicious use of the woodman's axe." From this announcement the reader will understand that all the woodwork of these cottages is quite of a rustic character; in short, even the mullions to the windows and the labels over them, as well as the architraves to the doors, both inside and out, are of unbarked poles.

Part I. contains a design for a peasant's cottage, including plans, elevations, two sections, a perspective view, plans and elevations of the chimney shafts to a scale of $\frac{1}{2}$ in. to 1 ft.; plans and elevations of windows to a larger scale, and a rustic chair and table to a scale of 1 in. to 1 ft.

Part II. contains a design for a forester's cottage, including plan of the basement and ground floor; elevation of the entrance and garden fronts; transverse and longitudinal sections; perspective view; plan of bay window, $\frac{1}{2}$ in. to 1 ft.; elevation of ditto, ditto; and plans and elevations of chimney shafts.

Our readers are now put in possession of the contents of these two parts, and the author informs us that each part may be forwarded by post, and on being requested to do so, he will be happy to comply pre-paid. Mr. Ricauti's address is No. 47. Great Russell Street, Bloomsbury Square, London.

A cheaper way for a gentleman in the country to get a design for an ornamental cottage can hardly be devised; and the working plans are all on such a large scale, that the building may be executed under the direction of any country carpenter. We therefore recommend a trial of one number of the work at least.

With respect to the taste of this novel feature of forming the mullions, labels, architraves, and facings to stone or brick walls, of unbarked trees, we cannot approve of it, on account of the incongruity of the materials. In general, the ornamental parts of a building are not only designed in more elaborate forms than the plain parts, but they are executed in a somewhat better material, or at all events in one not worse. Thus brick buildings have, for the most part, stone labels and mullions, and for a good reason: in the case of the mullions, there is the lintel to support, and in the case of the label, the rain to throw off. Now the action of the rain would soon rot both the rustic mullion and the rustic label, and while the walls would look bare and prematurely going to decay, the lintels of the windows would be falling in. We are quite aware from the plans that there are stone mullions behind the rustic ones, but in criticising an object which addresses itself chiefly to the eye, we must examine it, not as we know it to be, but as it seems to be. The difficulty, perhaps, might be got over, by covering the whole of the exterior walls with wood having the bark on; at all events, the novelty of this decoration and its rustic appearance will recommend it to many persons, and nothing can be better than for those that have time and money to try every thing. The only certain thing that every man attains in this world is experience. We make these remarks with great regard for the author, whom we have the pleasure of personally knowing, and consider to be a beautiful architectural draughtsman, and a very amiable person.

ART. VIII. *Illustrations of Indian Architecture.* By M. Kittoe. Calcutta. Parts I. to VIII. Oblong 4to. London, Allen. 12s. each.

THIS work differs from Ram Raz on Indian architecture, in consisting of a series of examples with their details, while the other endeavours to lay down the rules and proportions of the parts common to all buildings whatever in the Indian style. In short, the work of Ram Raz may be called the five orders of Indian architecture, and that of M. Kittoe its *Vitruvius Britannicus*. The publication will be useful to architects, by furnishing them with data for buildings designed in the Indian manner, and to gardeners, by the hints which it gives for laying out flower-gardens to accompany such buildings. As it must be interesting in India for an Englishman to build and lay out his garden in some of the manners common in his native country, so we think must it be to an Englishman who has made his fortune in India, to exhibit the style of the country to which he is so much indebted, in the scene of his retirement. Independently of this, the Indian style, if occasionally adopted even by those who have never been in India, would prove a source of novelty, differing from the novelty produced by the revival of our ancient styles, in being, as Addison long ago expressed it, "strange as well as new." The style,

we think, is particularly well adapted for street architecture; and hence the dealers in Indian articles are called upon to adopt it in their shop and house fronts. The kind of European architecture which comes nearest that of India is the Gothic; but the latter is inferior to the former in what may be called constructive decoration; that is, in ornaments which consist of lines and forms arising out of the arches to the openings, the bases and capitals of the columns, the cornices, the roofs, and all the different kinds of buttresses, towers, domes, pinnacles, and finials. With regard to Indian flower-gardens, the work before us contains six ideas for capital designs. These ideas are taken from the panels of parapets, as, in the Elizabethan and Moorish styles, they are taken from the compartments of ceilings. Architecture is one of those arts, the study of which, next to painting and sculpture, has the greatest tendency to call forth and improve the feeling or faculty of taste; and we are therefore particularly anxious that some attention should be paid to it by gardeners, and especially by such of them as have any pretensions to skill in laying out grounds. We wish that we could see published a collection of specimens calculated to show the general effect and the details of all the principal styles of architecture that have been adopted in the world, and carried to any degree of perfection; distinguishing in each the military, ecclesiastic, urban, and villa styles; and in styles that have been long cultivated, such as the Gothic, the different eras. Such a work at a moderate price, at the present time, would do more towards improving the public taste than almost any other that could be produced.

Contents. Vignette, a mausoleum in the suburbs of Benares, of the date of Shah Jehan.—The remains of the Palace of Forty Pillars, of the style of architecture of the reign of the Emperor Ackber. This building is of stone, brick, and plaster, with the dome covered with enamelled tiles of various colours; a good hint for covering domes in this country, where cement is used as a substitute for lead.—Ruin of a Mahomedan mosque in the citadel of Jounpur. Its ornaments and details are highly sculptured, and there is a detached pillar in the foreground of a highly ornamental character, admirably adapted for an object in a pleasure-ground where the style of the house was Hindoo.—Ruined mausoleum on the high road to Lucknow, commonly known by the name of Barahdurri, implying a palace or place of pleasure. Why such a building comes to be used as a mausoleum is stated in the following extract. "It was a custom with the Mahomedan princes and persons of rank and wealth, to lay out superb gardens, which were usually surrounded with high parapeted walls and turrets, with a grand entrance thereto on one of the faces; and in the centre of such enclosures they used to construct an edifice, more or less magnificent, according to their tastes and resources, which during their lifetime were used as barahdurris, or places of pleasure; and at their death they were buried therein, the building then becoming converted into their mausoleum and that of their families, the gardens were no longer resorted to as places of pleasure, but were assigned to one or more cadims or priests, who maintained themselves and the tombs chiefly by the sale of the fruits and other produce of the gardens; for larger buildings, however, grants of land were made in excess to the foregoing, the revenue of which was intended to be applied to such purposes; this custom is still prevalent, and such, therefore, is the origin of the term 'barahdurri,' or palace, being applied to monumental structures."—Gate and citadel of Feroz Shah, near the modern city of Delhi, built by the Mogul Emperor Shah Jehan. A good hint for an entrance-lodge to a villa in the Indian style.—The mosque Jamai Musjid. "The most striking feature in this wonderful edifice is the immense arch in the centre of the façade; it is near 100 ft. to its apex, consists of a series of arches one within the other, receding like a stair." The details of this building and some low buildings which surround it, afford excellent hints for composing a Hindoo village adapted to the climate of England. The same may be said of the next subject.—Sarai and bridge, near the town of Musanuggur.—Old Sarai at Himmutnuggur, near the city of Agra and the Secundra.

MISCELLANEOUS INTELLIGENCE.

ART. I. *General Notices.*

NEW or concentrated Manures. — The remarks by the Hon. and Rev. W. Herbert are excellent. I tried some experiments last year on the effects produced by different composts on the vine cultivated in pots. I took eight black Hamburg vines, and after shaking the mould they had previously grown in completely from the balls, I planted two in each of the composts below. There was no perceptible difference in the size or strength of the vines before planting. The first two were planted in equal parts of loam and perfectly decomposed stable dung; the second in equal parts of loam and bone dust; the third, in two thirds by weight of loam and one third of dressings from the clothiers, called here flocks; and the fourth were planted in 50 parts of loam, as above, and wood ashes 20 parts, lime 10 parts, soot 10 parts, and salt 10 parts. Their rate of growth was, 1st, those in loam and dung, which beat considerably any of the others in size of leaf, strength of stem, and rapidity of growth; 2dly, those in No. 3. compost, viz. loam and flocks; 3dly, those in loam and bone dust; and lastly, those in loam, wood ashes, soot, &c. The latter grew very badly, and made scarcely any root, though under exactly the same management. I regret I did not put any in pure loam, to see whether there is any actual benefit to be derived from using muriates and carbonates. Flocks are certainly a powerful manure, and, independently of keeping the earth porous and open, they retain their fertilising properties a long time. Perhaps some of your valuable correspondents have carried this subject farther than I have done, or can throw additional light on it. I will resume the experiments on a larger scale directly, and acquaint you with the results next spring. — *John Spencer. Bowood Gardens, June 4. 1840.*

Preservation of Wood. — At a recent sitting of the Academy, M. Boucherie presented a memoir "On the Preservation of Timber, by a Method peculiar to himself." That method consists in introducing pyrolignite of iron by absorption into the tissue of the wood, immediately after the fall of the tree, or even while it is yet standing. This simple operation is said to be remarkably efficacious: 1st, in protecting the tree against rot, dry or humid; 2dly, in increasing its hardness; 3dly, in developing and preserving its flexibility and elasticity; 4thly, in preventing the cracks which result from variations of the atmosphere when brought into use; 5thly, in reducing its inflammable and combustible characters; and 6thly, in giving it colours and odours at once varied and enduring. M. Boucherie laid before the Academy several specimens prepared by this method, the examination of which was referred to a committee. (*Athenæum*, May 16. 1840.)

The most remarkable part of this process is, the impregnation of the tree with the preserving substance while it is yet in a growing state. From the Report in *Le Temps* of May 7., which a correspondent has kindly sent us, it appears that the liquid is absorbed by the vital action of the tree while yet growing, or when newly cut down. Whether any thing fit to be introduced into general practice will be the result of these ingenious experiments, it is at present difficult to say. — *Cond.*

ART. II. *Foreign Notices.*

MADEIRA.

FUNCHAL, March 15. 1840.—I am glad to find by your letter of the 21st of January, that the account of my tea plantation in the mountains of this island

(see p. 113.) proved acceptable to you ; and I have requested your ; friend Dr. Lippold to see a plant of the Ceylon cinnamon in my garden in town, with a full crop of berries or acorns, which promises equal future advantages to this island, through its cultivation in the low lands, as the tea does in the mountains, and Dr. Lippold has taken a small branch with berries on it to forward it to you.

I have had this plant about eleven years, but all my endeavours to propagate it by layers or cuttings proved abortive, and though it often gave flowers, it never perfected its seed till last year, from which I succeeded in rearing fourteen young plants ; and from the beautiful condition of the plant and berries this year, I have every reason to hope that none of them will fail to germinate, so that I have now little doubt that I shall succeed in forming a plantation of this valuable spice in this island.

I feel much obliged for your information and suggestions regarding the manipulation of tea, and they entirely quadrate with my own ideas on the subject. The whole theory of preparing the leaves for tea is merely to destroy the herbaceous taste ; and the leaves are perfect, when, like hay, they emit an agreeable odour ; but I confess that to roll them up for package, in the way they are sent from China, so far as I have been able to accomplish it, is so tedious and expensive, that I despair of ever getting a profitable return from my plantation through that means ; but I cannot fail to agree with you, or resist the conclusion from the many experiments which I have made, that much useless labour is spent in the manipulation of tea, especially in rolling up the large green tea leaves, which, on examination, show that each leaf is rolled and folded by the hands separately. Your suggestion, therefore, of compressing the leaves into cakes or forms, seems to be a most feasible method of preparing them for package and preservation against humidity, the two great objects to be provided for ; and might, I conceive, be effectually accomplished by a hydraulic press. Your suggestion, I think, therefore, may prove of the utmost advantage to the Indian government or Assam speculators, for if I cannot succeed in rolling up the leaves with the dense population of these mountains, which admits of my employing young women at about $4\frac{1}{2}d.$, and boys and girls at about $2\frac{1}{2}d.$ sterling per day, in that occupation, how will it be possible in Assam to succeed, or compete with the overplus population and cheap labour of China.

Compression would have a great advantage over rolling up the leaves, as it would take place when the leaves are perfectly dry, whereas the latter can never be effected except when the leaf is in a moist state ; hence the necessity of roasting and re-roasting them in copper pans of a conical shape before embarkation, to prevent mustiness, which, from the acid of the tea acting on the copper, causes the astringency in all the teas sent to Europe. I have one of these pans, which was brought from China, and others in iron, made in imitation thereof, and beautifully executed and plated inside, by Mr. Harrison of Liverpool. Still the trouble of rolling up any other than the small young leaves, which can be effected on a sort of basketwork tablet (of which I have one of those used in China, made of the bamboo cane), seems to me to be impossible to accomplish without great expense. If, however, the tea leaves compressed into shapes could be brought into vogue, I could prepare immense quantities at this island, and afford to sell the tea much cheaper than that brought from China ; while it would possess the double advantage over the practice of rolling up the leaves, of being both more wholesome and better calculated for package and preservation. For as to the plants, it is impossible they can succeed anywhere better than they do in the mountains of Madeira ; and where the *O'lea fragrans*, the flower of which is used to scent the teas, the black in particular, grows with a luxuriance quite incomprehensible to those who have seen it grow elsewhere, forming a small plant for the flower-bed in the low lands of this island, and growing up almost to a tree in the mountains. I have reason to believe, also, that the

tea plants grow here to a greater height and with greater luxuriance than they generally do in China. — *Henry Veitch.*

ART. III. Domestic Notices.

ENGLAND.

THE Horticultural Fête at Chiswick, June 13. — There are few public exhibitions in the neighbourhood of the metropolis that give such universal pleasure as these fêtes; and the increasing number of visitors, as well as the rarity of the plants exhibited, fully prove that the love for horticultural science is spread among all classes. Saturday's show was one of the best we ever witnessed, and the rarity of the kinds, and the fine specimen plants of the *Orchidaceæ*, were, we believe, never before equalled at any show, either in London or elsewhere. Among the more remarkable was a very large specimen of *Aérides odorata Lou.*, covered with pendulous racemes of deliciously scented white flowers; this plant is a native of China, and when in flower is commonly hung up in baskets in the living-rooms of the Chinese, for the sake of its odour. *Saccolabium guttatum Lindl.*, and *S. præmorsum Lindl.*, both very beautiful plants with long crowded racemes of lilac flowers; a new species of *Coryánthes*, with curiously spotted flowers; *Burlingtonia candida Lindl.*, with delicate white blossoms; brassias, gongoras, and peristerias, of several species, were equally deserving of notice. A fine plant of *Cynòches Loddigèsii Lindl.* was in full beauty, and perhaps, for form, one of the most remarkable of the order. If the flower is inverted, the column will be found to bear a considerable resemblance to the arched neck of a swan, whence its generic name. *Oncidium Lanceanum Lindl.*, with fine purple and green spotted flowers, is, perhaps, the pride of the order; and *Vanda tères Lindl.*, with its beautiful purplish pink flowers, scarcely less beautiful, were in finer flower than we have ever seen them before. It is almost useless to attempt describing this extraordinary order of plants, which alike surprise us by the beauty of some, and the grotesque appearance of others; and we can only exclaim with Milton,

“These are thy glorious works, Parent of good.”

The pelargoniums were much finer than usual; those from Messrs. Cock and Catleugh were astonishing, from the beauty and large size of the plants, as well as from the immense masses of flowers they produced. Mr. Foster's seedlings were also remarkable. The calceolarias it is almost needless to mention, as they were much the same kinds as those exhibited at the last show. *Pentlândia miniata*, a rare and beautiful bulbous plant with scarlet tubules, was splendidly in flower. The various species of ixoras were, as usual, among the most showy plants exhibited. Two or three species of *Gompholobium*, trained over wires, were in very fine flower. A new leguminous plant from Swan River, with spikes of purplish flowers, said to have been introduced by Captain Mangles, was very handsome, and quite distinct from anything we have yet received from that part of the world. The collections of cut roses were much more extensive than usual, and the competition very great. *Rondelètia odorata*, with finely scented orange scarlet flowers, was in a state of high perfection. A very large plant of *Stephanòtis follicularis*, from Mrs. Lawrence, was particularly fine. It is a new climber, with fine dark green coriaceous leaves, and very odoriferous white flowers; the plant exhibited, we believe, is the largest in the country, and we hope to see it obtain the attention it merits. The above-mentioned plants were among the most remarkable; but on the whole, though the number of rare plants was much greater than at the last show, yet, from the want of those fine masses of colour produced by the white azaleas and scarlet epiphyllums, it was not nearly so striking. The company present included many of the nobility, and, it is ascertained, exceeded 11,000 persons. — *W. A. M. London, June 15. 1840.*

The *South London Horticultural Society's Show* took place June 16. in the Surrey Zoological Gardens, and we were not a little pleased to see the gradual improvement that is going on in the Society. The pelargoniums from Mr. Catclough were, if possible, more beautiful and numerous than they were at the Chiswick show. Among the more remarkable were, a new seedling, not yet named, decidedly the richest in colour hitherto raised; Sylph, Grand Duke, Gauntlet, Prima Donna, &c. The other plants worthy of notice were, fine specimens of *Clématis Sieböldtii*, *Nephródium fulvum*, *Thunbérghia grandiflora*, *Verbèna Melindres*, and its varieties, alstrœmerias, &c. The cut roses were very numerous, and the competition severe. The whole were well arranged under spacious tents, and the company was large and apparently well pleased. — *W. A. M. June 17. 1840.*

Mr. Read's Hydraulic Machines. — The gardening world are greatly indebted to Mr. Read, for his various inventions for throwing water on plants. Had he never produced anything more than his syringe, which has now been upwards of twenty years before the public, his services would not have been forgotten; but he has gone on in a course of improvement, and one of his latest inventions, and that which he says is his masterpiece, is a barrow-engine, which he thus describes:—

“*Fig. 45.* is an oval copper vessel, containing 26 gallons, particularly adapted for large conservatories and forcing-houses of all descriptions. It will pass through a doorway 2 ft. wide: its power is equal to any barrow-engine, and it is admirably well adapted for a local fire-engine. It is so portable that it can be carried up or down stairs by two men; and it may be kept in a hall, on a staircase, or even in a bedchamber. The valves being of solid metal, the machine cannot get out of repair, and it is consequently ready to act in an instant.” — *J. R.*

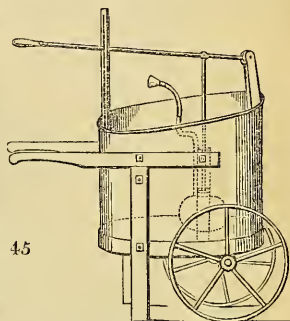

Opening Public Gardens and Museums to all the Public. — The Town Council of Liverpool has purchased the right from the proprietors of the Botanic Garden, of throwing it open on Sundays, and one other day in every week, to all the population. We sincerely hope this example will soon be followed in all other places where there are Botanic or Zoological Gardens. We should wish to see this done without delay in the case of the Zoological Gardens in the Regent's Park and Surrey, and also in the case of the Chelsea Botanic Garden and the Horticultural Garden at Chiswick. If the whole of the metrópolis and the immediate suburbs were put under the general management of a municipal council or government, it would be the duty of that body to purchase certain rights from the proprietors of museums, gardens, &c., on behalf of the public; and to form other places of recreation and amusement, such as gardens, parks, &c., at the expense of their government, and for the benefit of all the population; and this more particularly on Sundays, when all who labour hard during the week generally take some recreation. We do not see why a rate should not be raised for maintaining a garden, as well as for maintaining a public school. Both are but different modes of supplying education; and, next to the school, we are convinced that the study of nature, and more particularly of plants and animals, has most effect in exciting the thinking faculties, and humanising both the heart and the mind.

Nothing could have added to the satisfaction that we experienced on noticing the intentions of the proprietors of the Liverpool Botanic Gardens, except a motion made in parliament by Mr. Hume, to the effect that he intends to move an address to Her Majesty, to direct the Trustees of the British Museum and the National Gallery to permit those two establishments to be open to the public from 1 o'clock to 4 o'clock on Sundays. The public

1840. JULY.

B B

are under an everlasting debt to Mr. Hume for the exertions which he is continually making in their favour; and if he could once get the principle recognised, of the usefulness of admitting the public to all kinds of exhibitions at proper hours on Sundays, he would, in our opinion, do the greatest good, next to that of establishing a system of national education in the manner of some of the Continental systems, by which it would be impossible for any person to grow up in this country without being educated more or less in every branch of useful knowledge. Of some such system Mr. Hume has been for many years an advocate. We most sincerely hope that Mr. Hume's address may be attended with the desired result; and that the queen's advisers will show that they are not without sympathy for the great mass of their fellow-creatures. — *Cond.*

SCOTLAND.

Queen Mary's Tree. — This memorable tree, which has braved the blast of centuries, yielded to the fury of the gale on Monday last. It stood at the east end of the village of Duddingstone, and nearly opposite Lord Abercorn's park. It was, perhaps, one of the oldest thorn trees in Scotland, and of the largest dimensions. Its exact measurement we do not at present recollect,

43



but we know that two men embracing its trunk at opposite sides could not make their hands meet. It was commonly called Queen Mary's Tree, though, it is probable, it was planted before her reign. It formerly stood within a park, but on widening the carriage road about ten or twelve years ago, it was brought outside; and then it seemed on its last legs, several fissures appearing in the trunk, through which the elements of air and water were fast consuming the venerable tree. The road trustees had these fissures filled up with stone and lime, and had it otherwise protected; but the violence of the gale on Monday pulled it up by the roots, laying it along, a shattered and withered trunk; and thus another of the memorials of the unfortunate Mary has perished in the vicinity of her Holyrood. (*Times*, June, 1840, from an Aberdeen paper.) The thorn tree above mentioned was measured by Sir Thomas Dick Lauder in 1818, and again in 1836 by Mr. Barnet, then curator of the

Caledonian Horticultural Society's garden, for the *Arboretum Britannicum*. Its dimensions were: girth at 3 ft. above the ground 9 ft.; at the ground 12 ft.; height 43 ft.; diameter of the space covered by the branches 44 ft. Why it is called Queen Mary's tree, we do not know. The tree in the neighbourhood of Edinburgh called Queen Mary's Thorn (see *fig.* 46.) stands in a garden on the opposite side of the town, and, though it is known to be nearly 300 years old, is still healthy and vigorous, as our engraving indicates. It is a weeping variety, and is the *Crataegus Oxyacantha pendula reginæ* of the Fulham Nursery, and other collections. — *Cond.*

IRELAND.

Belfast Botanical Society. — The Annual Meeting of this Society was held May 16., when reports were read from the secretary and the curator. The recommendation of the former Committee, unanimously approved of by the General Meeting, for the erection of a range of glass in the garden, had been followed by the appointment of a Sub-Committee, whose report on the practicability of the object, and the means for accomplishing it, was received on the 29th of May last. The General Committee, after having duly considered the report, expressed a favourable opinion of the feasibility of the work, and turned their attention to procuring information on the most improved mode of constructing, heating, and ventilating the projected houses. The information obtained was submitted, in the form of a report, to a special General Meeting; a design of the intended range of glass was furnished by Charles Lanyon, Esq., and an estimate by Messrs. Turner and Walker, of Dublin. The General Meeting, on the 24th of August, was pleased to adopt the report and the design, and authorised the Committee to carry into effect such portion as was within the means of the Society. The Committee, accordingly, procured, from Messrs. Turner and Walker, an estimate for the erection of two houses, measuring 65 by 20 feet, which was as much of the range as came within their means. Mr. Lanyon having pronounced the same reasonable, the Committee contracted for the work. The contract, which was read to the meeting, stipulated for the erection and completion of the work, in accordance with Mr. Lanyon's design, and in such a manner as would give entire satisfaction to the Society, for the sum of 1,400*l.* The Committee had hitherto been able to fulfil their engagement with the contractor, in a satisfactory manner; but they thought it right to state, that, in doing so, they were indebted to the liberality of some individuals of their body, in making advances beyond their usual contributions, which are to be provided for hereafter. The report went on to state, that, out of a proprietary of 370 shareholders, and 308 subscribers, only 93, or under one seventh, as yet contributed to the building of the green-houses. The Committee, in their former report, might appear to have been over-sanguine; but, when the above circumstance was considered, and the unforeseen state of the money market during the period mentioned taken into account, they conceived they might be excused for entertaining hopes which a moderate degree of cooperation, on the part of the members, would have realised in a very short period. The wetness of the past season had protracted the completion of the works at the time specified; but the Committee had satisfaction in reporting that one house was now ready for the reception of plants, and the other in rapid progress. Though their plan was different from that of any other in the empire [We should be greatly obliged to Mr. Lanyon for some account of it], persons of experience considered that the houses were, in every respect, calculated to answer their intended purpose; possessing also a high degree of architectural beauty, while the general utility of the plant-house had in no degree been sacrificed. The Committee hope that their exertions, in training up native youths, of respectable parents, to a branch of industry so little cultivated, will ultimately be duly appreciated by the nobility and gentlemen of the Province, whom it more immediately concerns than the manufacturing and mercantile classes, by whom the burthen of the establishment has been hitherto almost exclusively borne. The Committee

urge the advantage of procuring the attendance, in the evenings, of a respectable person, to improve the grammatical education of the boys; and the benefit of establishing a school in the neighbourhood of the garden (a locality where it is much wanted). They referred to the laudable example of the public gardens in Scotland, where the education of the youths does not cease on their becoming apprentices. With respect to expenditure, the Committee state that that part under the control of the curator has not exceeded the expense of former years, though the garden is in a much higher state of keeping. Extra-expense has, of course, been incurred, in consequence of the contract, in forming the grounds and lawn in front of the buildings, in repairing walks injured by carting materials, in draining and trenching the lawn in front of the curator's house, in drain-tiling walks, &c.; but, when the greater part of these works is considered to be permanent, and when the cost is compared with that of other establishments, the Committee express their opinion, that much credit is due to the curator for economy and anxious exertion to meet the wishes of his employers. As a proof of the increasing popularity of the garden, the report stated, that the number of visitors had vastly exceeded even last year's; while the list of shareholders and annual subscribers had also been augmented.

The curator's annual report stated that, among other operations in the garden, since the last annual meeting, the ground in front of the new buildings had been levelled and prepared, to correspond with the park at the head of which the houses stand, so as to give the best aspect the situation admitted of. The line of the former cross-walk had been altered, and lowered at the west end, so as to give sufficient elevation to the base of the building on that side. Considerable additions had been made to the rockwork round the middle pond, now considered the most interesting spot in the garden; and many strangers have pronounced this piece of rockwork the most natural they have seen. About 300 species of plants have been added to the British collection, now containing nearly 700. The natural arrangement has also been considerably increased. The ground which was formerly occupied as a nursery has now been converted into a garden for fruit and culinary vegetables. It contains three fourths of an acre, and will, consequently, afford good scope for rearing vegetables of the most approved sorts, and hardy fruit, besides affording the apprentices an opportunity of acquiring a thorough knowledge of horticulture and botany, as well as the cultivation of plants. At present, there are four highly respectable and well-conducted lads in the garden, who, it is expected, will soon be extremely useful to the curator, who suggests that they should be supplied with a collection of books similar to those used in other botanical establishments. The exotic arboretum, formed two years since, is in a state of perfect health, and many of the plants flowering beautifully. The curator had visited Dublin, Glasgow, and Edinburgh, and added considerably to the collections, from public and private botanical institutions in these places, with which the most friendly intercourse subsists. It is considered, that by these additions, and the numerous donations receiving, the Belfast Botanic Garden bids fair to hold a place with most other collections in the kingdom. During the past year, the number of visitors, including those present at the midsummer fête, amounted nearly to 50,000, among whom were strangers of distinction, from various parts of the world.

Mr. J. Montgomery stated, as evidence of the increasing popularity of the garden, that, from 29th April, 1839, till the 29th Feb. 1840, a period of little more than ten months, the visitors amounted to 29,578.

Mr. Robert Patterson made a suggestion, for the consideration of the Committee, that respectable tradesmen, with their wives and families, should be admitted into the garden, on one evening in the week, for two or three months of the summer, on the recommendation of a subscriber, and on payment of such trifling sum for admission as should be within their means. It was decided, however, that this meeting had no power to press a rule on the subject, as one of the fundamental rules of the Society would be infringed by it. (*Northern Whig*, May 19. 1840.)

ART. IV. *Botanical Garden (Kew).*

COPY of the REPORT made to the Committee appointed by the Lords of the Treasury in January, 1838, to enquire into the Management, &c., of the ROYAL GARDENS, by Dr. *Lindley*, Professor of Botany, who, at the request of the Committee, made an actual Survey of the BOTANICAL GARDEN at *Kew*, in conjunction with Messrs. *Paxton* and *Wilson*, two practical Gardeners, in the Month of February, 1838. Printed by Order of the House of Commons in May, 1840.

THIS garden is situated on the south side of Kew Green, bounded partly by the walls of the royal forcing and kitchen garden, and partly by what is called the pleasure-ground of Kew Palace. It is reported in the official returns to occupy 15 acres, of which a part is arboretum, and the remainder filled by stoves and green-houses, borders of herbaceous plants, spaces left for the arrangement of green-house plants in the open air in summer, offices, yards, &c.

The arboretum contains many very fine specimens of hardy exotic trees and shrubs; but the collection is not very extensive, and the plants are too much crowded; they are mostly marked with labels, numbered, and referring to a private catalogue in the garden.

The collection of herbaceous plants appeared to be inconsiderable. A certain number were marked with their names written on painted sticks; others were unnamed; no systematical arrangement was observable, with the exception of grasses, of which there is an extensive collection named.

The stoves and green-houses have been built, with two exceptions, in the neighbourhood of each other, in an irregular manner, and, apparently, from time to time, as occasion arose for successive additions. Some of them are old, but in general they are in pretty good repair. They may be described as follows:—

1. A palm stove, 60 ft. long, containing, among other things, some fine old palm trees planted in the ground.

2. A stove, 50 ft. long, filled with a miscellaneous collection of stove plants.

3. A stove, 60 ft. long, with two small tanks for water plants, occupied by a miscellaneous assemblage of stove plants.

4. A small span green-house, 40 ft. long, with a miscellaneous collection of small New Holland and Cape plants.

5. A dry stove, 40 ft. long, in two compartments, filled with succulent plants.

6. A green-house, 60 ft. long, chiefly filled with fine specimens of Cape of Good Hope and New Holland plants, among which are some noble banksias.

7. A double propagating pit and hospital, 35 ft. long, with cuttings under bell-glasses and sick plants in one division; ferns, orchidaceous plants, and some other valuable specimens in the other.

8. A green-house, 30 ft. long, containing small Cape of Good Hope and New Holland plants.

9. A "Botany Bay" house, 110 ft. long, crowded with magnificent specimens of New Holland and other plants, especially the former.

10. An old stove, reported to be the first house erected in the garden, 110 ft. long, in three divisions; one containing noble specimens of succulent and other plants; the second, a stately *Zamia púngens*, palms, &c.; and the third, a miscellaneous set of green-house plants, together with a few forced flowers for nosegays.

Many of those houses have brick pits attached to them on the outside, and there is a damp pit for raising seedlings in. All the houses are heated by separate fires, and great inconvenience appears to result from the soot produced by so many chimneys.

The first thing to remark upon the specimens in the houses just described

is, that they are excessively crowded, and some of them are out of condition from this circumstance. In general, however, the plants, especially those from New Holland, are in excellent health, clean, and well attended to; the general appearance of the collections was, moreover, very creditable. The second subject of observation is, that a great many plants have been newly labelled, with their names written on painted sticks, especially in the houses Nos. 2. 5. and 10., but that the principal part of the collection is otherwise unnamed. There is, moreover, a very considerable quantity of small young plants in pots, many of which would be valuable for distribution.

In the pleasure-ground is a fine old orangery, 130 ft. long, easily heated by the fires. It is filled with orange trees, araucarias, New Holland and other plants, many of which are of great size.

In another part of the pleasure-ground, adjoining the arboretum, there has been recently erected an architectural green-house, 82 ft. long, 42 ft. wide, and 28 ft. high; it is unoccupied, a heating apparatus warmed by twelve fires, buried in the vaults of the building, having been only just completed.

There is also in the garden a clerk's office for the transaction of business, and stabling for the horses employed in this establishment, and that of the forcing and kitchen garden adjoining.

The director-general has a house near the garden, and a small dwelling is provided for one of the foremen.

So far as the mere cultivation of this place is a subject of observation, it is due to those who have charge of it to say that it does them credit, considering the crowded state of the houses, and the inadequate funds allowed for its support.

It is impossible to speak of the general management in similar terms. It has always been maintained as the great botanical garden of this country, and, whether as a private or as a public establishment, it was the duty of the officer intrusted with its administration to render it effective to the extent of his means as a botanical garden, that is, as a garden of science and instruction; yet no kind of arrangement (one of the first features in a botanical garden) has been observed; no attempt has been made, till lately, to name the multitudes of rare plants it comprehends, and thus to render it a place of public utility; no communication is maintained with the Colonies, nor any other thing done, so far as can be discovered, to fulfil the objects of its institution, except to raise the seeds which government collectors and other persons have profusely contributed, and then to take care of the plants.

It is admitted that there is no classification observed in the garden.

What names are to be found in the garden have been furnished by Mr. Smith, the foreman, and the director does not hold himself answerable for them. This was most particularly enquired into, and most distinctly avowed; so that by far the most difficult part of the duty of the principal officer, a duty on the perfect execution of which the credit and utility of the garden essentially depends; a duty which can only be executed properly by a man of high scientific attainments, aided by an extensive herbarium and considerable library; this most important duty is thrust upon a foreman, paid small weekly wages for cultivating plants, who, whatever his zeal and assiduity may be (and in this case they have been such as to deserve the greatest praise), has no sufficient means of executing such an office. A considerable number of names have been very recently affixed to the plants; and Mr. Aiton is so anxious to declare his opinion of their utility, that he has written the following letter upon the subject:—

Royal Botanic Garden, Kew, February 22. 1838.

Sir, To correct any misunderstanding as to my opinion of naming plants in the garden, I take this opportunity to state, that, for the advantage of the visitors generally, as well as for the instruction of the gardeners in employ, I consider each individual species should be distinctly and carefully labelled with the ascertained scientific name, &c. I am, &c.

To Dr. Lindley.

(Signed) W. T. AITON.

It is difficult to reconcile this statement with the fact, that up to a recent period no means had been taken to carry such an object into effect.

That no communication is maintained with colonial gardens is apparent from the garden-book of deliveries, an abstract of which, from the year 1805, is annexed. It will be seen from this document, that since the year 1830, the only deliveries to colonial gardens, or in aid of the British government, have been one to the garden of New South Wales, and one to Lord Auckland, when proceeding to his government in India. Mr. Aiton states that all such applications have been complied with, but that the garden cannot be saddled with the expense of fitting up boxes for exportation. It appears, however, that the principal expense of such trees is defrayed by the Board of Works. It is well known that a great desire is felt in the Colonies to procure plants from this country; it is equally well known that applications to other gardens for such assistance are extremely common; it is therefore singular that what happens so frequently elsewhere, should so seldom happen in the Botanical Garden of Kew.

Visitors are unreservedly admitted to the garden daily, except on Sundays, and Mr. Aiton deserves credit for having exercised his power, as director-general, in order to secure this privilege to the public. It is, however, not easy to discover what advantage, except that of a pleasant walk, has been derived from the privilege in the past state of the garden.

A supposed difficulty in obtaining from this garden any of the duplicate plants to be given away, has been the subject of a great deal of public discussion for many years; and attention having been called to it by the Committee, very particular enquiries have been made into the truth of the common opinion. Mr. Aiton states that in this matter he has acted upon his own judgment, and by virtue of his authority as director-general of the royal gardens; that he has always considered the Botanical Garden a private establishment; that the only rule which he has observed in giving away duplicates has been, to assist those who were likely to aid the garden in return; and that, in his opinion, it is desirable that the garden should be conducted upon the most liberal plan, consistent with the safety of the collections.

Undoubtedly it has been in one sense a private garden of the crown, inasmuch as its ordinary charges have been defrayed by the Lord Steward's department; but, on the other hand, all the large expenses for foreign collectors having been for many years paid by the Treasury or Admiralty, it must be considered, to a certain extent, a public garden also.

Upon examining the book of deliveries before alluded to, and of which the abstract is appended to this Report, it appears that in the course of the last 32 years there have been 28 deliveries to the British Colonies, or to persons residing in the foreign settlements belonging to the British Crown; 36 to various branches of the Royal Family; 21 to specific institutions in this country; 227 to private individuals in this country; and 171 to foreigners; in all 483, or about 15 a year.

Mr. Aiton has sent the following letter in explanation of this:—

Royal Botanic Garden, Kew, February 22. 1838.

Sir, Agreeably to the request conveyed to me in your letter of the 20th instant, I send you an abstract of all deliveries contained in the garden-books, together with the names of the persons to whom the same were forwarded; but the residences not being always inserted is the cause of several omissions in this particular. Many plants, seeds, and cuttings, in small quantities, have been given to amateurs, of which no account has been taken. It should be, however, particularly observed, that the royal collection has been required to supply great quantities of flowering and other plants in the reign of His late Majesty King George the Fourth, especially for the conservatories at Carlton House, the King's House, Lodge at Windsor Park, the orangery at the Castle; and that these supplies being only from one to another of the royal gardens,

many of these deliveries were not entered in the garden-books. There have been also considerable numbers of plants sent to the royal palaces on birthdays, birth-nights, and other grand entertainments, on which occasions many losses have been sustained.

With this explanation of a great dispersion of plants from the Royal Botanic Garden, and bearing in mind that of the two collectors sent abroad in 1814, one was recalled in 1823, the other in 1830, by the Lords of the Treasury, thereby cutting off the usual resources for replenishing the losses, &c., of the garden, and that also within the last 10 years the allowance for keeping this garden being reduced nearly 600*l.* a year, it is evident that adequate means of late years have not been afforded so as to support a more extensive and more valuable collection; nor could a greater distribution of plants be reasonably expected by the public, were it generally known that the Botanic Garden at Kew was originally formed at the private expense of the Royal Family, and has been maintained up to the present time in like manner with the other departments of the household establishments, the estimates of the expense being regulated and defrayed by the Lord Steward and the Board of Green Cloth.

To Dr. Lindley, &c. &c. &c.

I am, &c.,
(Signed) W. T. AITON.

It is perfectly true that the garden means have been much curtailed for the last 10 years; but this seems, upon the whole, to have been advantageous to the public; for of the 483 deliveries in 32 years, 208 have taken place in those last 10 years, and the smallest number occurred in the years 1809, 1810, 1811, 1812, 1813, and 1814, when the deliveries did not quite average five a year; in 1811, they amounted only to two, and at this time it may be presumed that the garden possessed the greatest resources.

After all the explanation that has been offered; after allowing full weight to the assertion that the Botanical Garden at Kew has always been a private establishment; admitting, moreover, that a larger number of plants has been given away than is generally supposed, and that in many cases applications for plants have been liberally complied with, which is undoubtedly the fact, it really does seem impossible to say that it has been conducted with that liberality or anxiety to promote the ends of science, and to render it useful to the country, which it is usual to meet with in similar institutions elsewhere.

So far as the Lord Steward's department is concerned, the Botanical Garden at Kew is a dead weight upon the civil list; for, unconnected as it is with any of the palaces now occupied as royal residences, it has become a mere magazine of materials, very valuable, no doubt, with which to stock the other royal gardens: it would require a very large outlay of money to render it at all suitable for a royal pleasure-ground, and it does not appear to be wanted, now that Buckingham House has become the London palace, with a fine garden to it: moreover, the public will always expect that the only extensive botanical garden in the country should be available for public purposes. It is therefore recommended that the Lord Steward be relieved from the burden of this garden, unless it should be Her Majesty's pleasure to retain it.

If the Botanical Garden of Kew is relinquished by the Lord Steward, it should either be at once taken for public purposes, gradually made worthy of the country, and converted into a powerful means of promoting national science, or it should be abandoned. It is little better than a waste of money to maintain it in its present state, if it fulfils no intelligible purpose, except that of sheltering a large quantity of rare and valuable plants.

The importance of public Botanical Gardens has for centuries been recognised by the governments of civilised states, and at this time there is no European nation without such an establishment, except England. The most wealthy and most civilised kingdom in Europe offers the only European example of the want of one of the first proofs of wealth and civilisation. France, Prussia, Austria, Bavaria, Russia, Hanover, Holland, not to mention smaller governments, have all botanical gardens, liberally maintained with

public funds; and, what is more curious, Dublin and Edinburgh have similar establishments, to which grants of public money have been liberally furnished; but London has nothing, except a small garden at Chelsea, maintained by the funds of a private corporation. It has usually happened that botanical gardens have been established to meet the wants of universities; and so long as London was not the seat of a university, the necessity of establishing a public botanical garden was less pressing than it is at present. Now that a great number of students are annually collected in London for the purpose of study, it has become indispensable that such means of instruction as a botanical garden affords should be provided. It appears, from returns obtained from the Society of Apothecaries, that annually, on an average of the last three years, as many as 433 medical students have been registered as attending lectures on botany in London: they are compelled to attend these lectures, not only by the Apothecaries' Society and the College of Surgeons, but by the regulations of the army and navy; and yet this large number of young men studying the most important of professions, is practically deprived of the advantages of referring to a botanical garden, without which it is impossible that their studies can be prosecuted efficiently. It is true that there is a Botanical Garden at Chelsea belonging to the Apothecaries' Society, but it is not to be expected that the funds of such a corporation, however liberally disposed it may be, should suffice for the maintenance of such a botanical garden as the wants of students render necessary.

But this is only one out of many reasons why a National Botanical Garden should be maintained by Government near London.

There are many gardens in the British Colonies and dependencies: such establishments exist in Calcutta, Bombay, Saharanpur, in the Isle of France, at Sydney, and in Trinidad, costing many thousands a year: their utility is very much diminished by the want of some system under which they can all be regulated and controlled. They are in a similar condition to the Royal Forcing and Kitchen Gardens already disposed of; there is no unity of purpose among them; their objects are unsettled; their powers wasted, from not receiving a proper direction; they afford no aid or assistance to each other, and it is to be feared, in some cases, but little to the countries in which they are established; and yet they are capable of conferring very important benefits upon commerce, and of conducing essentially to colonial prosperity.

A National Botanical Garden would be the centre around which all those minor establishments should be arranged; they should be all under the control of the chief of that garden, acting in concert with him, and through him with each other, reporting constantly their proceedings, explaining their wants, receiving their supplies, and aiding the mother country in every thing that is useful in the vegetable kingdom. Medicine, commerce, agriculture, horticulture, and many valuable branches of manufacture, would derive considerable advantages from the establishment of such a system.

From a garden of this kind, Government would always be able to obtain authentic and official information upon points connected with the establishment of new colonies; it would afford the plants required on those occasions, without its being necessary, as is now the case, to apply to the officers of private establishments for advice and assistance.

Such a garden would be the great source of new and valuable plants to be introduced and dispersed through this country; it would be a powerful means of increasing the pleasure of those who already possess gardens, and, what is far more important, it would undoubtedly become an efficient instrument in refining the taste, increasing the knowledge, and augmenting the amount of rational pleasures of that important class of society, to provide for the instruction of which has become so great and wise an object with the present enlightened administration.

Purposes like these could not be effectually accomplished with such a place as the Botanical Garden of Kew now is. The present establishment would, however, form an admirable foundation; and the facility of reaching it, either

by land or water, renders it impossible to select a better site in the vicinity of the metropolis.

To make it effective, it should be enlarged by the increase of at least 30 acres from the pleasure-grounds of Kew. Considerable additions should be made to the houses ; every thing should be systematically arranged and named ; there should be distinct departments, both in the open air, and in houses, for medicinal, economical, and agricultural plants ; nurseries would be required for the propagation of plants for Government exportation, or for public purposes ; gratuitous lectures should be given upon botany in a popular form, but not as a regular academical course ; the most beautiful specimens of the vegetable kingdom should be carefully preserved for exhibition ; in short, the Garden should be perfectly adapted to the three branches of instruction, exhibition, and supply.

There is no sort of difficulty in effecting all this, and more, except the cost. To render it perfectly effective, would certainly not cost altogether at the utmost above 20,000*l.* ; 4,000*l.* a year would certainly pay for the maintenance afterwards, exclusive of repairs, and towards this sum it is not at all improbable that the Apothecaries' Society might be disposed to contribute, provided such an arrangement were made as would satisfy them that the objects of their garden at Chelsea, in that case to be abandoned, would be fulfilled.

It is inconceivable that Parliament would refuse the money for this purpose if the Garden were really remodelled with a view to such objects as those just described.

The only difficulty that is anticipated in the working of such an establishment is, the manner of distributing the plants through the country, and this is certainly an embarrassing subject.

There now exists so great an eagerness to procure new and beautiful plants, that to give the public any thing like a right to ask for duplicates from Kew, would be to make a signal for a general scramble, which might end in the destruction of all that is valuable in the establishment ; or if the officer in charge of the Garden had firmness enough to resist powerful applications on the one hand, and equally powerful demands upon the other, he would probably find the charge so disagreeable as to be disgusted with it, or he would be driven to make an unwilling compromise between his duty and the difficulties of his position.

At the same time, nothing can justify the present system in a public garden.

It has been proposed to sell the duplicate plants : so long as the Garden remains in the Lord Steward's department, it is impossible to sanction such a measure, which would be incompatible with the dignity of the Crown ; but if the Garden is placed under the Commissioners of Her Majesty's Woods, &c., the objection is not only removed, but the plan becomes, upon the whole, the least objectionable of any, and in that case such a system as the following might be adopted :—

1. To secure at least two specimens for the garden.
2. To supply Her Majesty's gardens.
3. To sell by auction annually all disposable duplicates. It is of course impossible to say what income would be derived from this, but the value of the plants would much depend upon the opinion the public might entertain of the chief officer of the garden, whose business it would be to determine the names of the plants to be sold.
4. To propagate nothing except what is wanted for Government purposes, and so far as the raising new plants from seeds can be called propagation.

In addition to this, there should be vested in the chief officer of the Garden a power of making exchanges with private individuals in this country at any time, and also with foreign gardens, after the wants of the British public are satisfied.

If Parliament were to grant a sum for rendering Kew a great national garden, Her Majesty's Commissioners of Woods, &c., would be relieved from a

considerable annual burden ; for it appears that since the year 1834 inclusive, the cost of repairs, &c. has been as follows :—

	£	s.	d.		£	s.	d.
1834 - -	497	11	0	1836 - -	881	4	0
— - -	483	15	0	— - -	4,183	18	4
1835 - -	825	4	8	1837 - -	449	0	0
— - -	621	0	0				
					<u>£7,941</u>	<u>13</u>	<u>0</u>

and the charge of ordinary repairs is not at all likely to be diminished under any arrangement, except that of entire renovation.

As there is no necessity for effecting alterations in this Botanical Garden otherwise than gradually, no sudden burthen need be thrown upon the public on that account.

ART. V. *The West London Gardeners' Association for mutual Instruction.*

MONDAY Evening, Feb. 17. 1840. — Mr. Shearer brought forward his paper "On the Culture of Mushrooms." He would recommend to have a house built for the purpose at the back of a pine stove, hot-house, or any other building, of dimensions according to the quantity required. The house in which he has grown mushrooms with the greatest success was 10 ft. inside the walls, with a row of shelves $3\frac{1}{2}$ ft. wide on each side, a space in the middle 3 ft. wide for a double flue. The first shelf was 2 ft. above the level of the flue, and 18 in. between the top and bottom of each of the shelves above that; the shelves were 10 or 12 inches deep. The flues were the height of six bricks laid flatways, and 8 in. wide inside, leaving between them a cavity of 4 in.; the whole was covered with flagstones. Cast-iron ventilators were put in about 3 ft. apart up the centre, to allow the heated air to ascend from the cavities between the flues, which run parallel with the shelves the whole length of the house, and return by the back wall to the chimney over the fireplace. The door was at one end of the house, and light was admitted from windows in the roof. The materials he preferred were horse-droppings, which had not been exposed to wet or to fermentation, but collected from the stable with a quantity of short litter sufficient to raise the temperature of the bed to about 65° , to be firmly rammed when put on the shelves about 8 or 10 inches deep, but if dung is scarce, 6 in. will do; in two or three days it will be fit to spawn. For procuring spawn plentifully, he would recommend any of the three following methods. In the month of June to take small pieces of spawn, to place them in communication with the droppings which have been left in places where brood mares and other horses had been kept; in September following, plenty of spawn will generally be found superior to any in bricks. Secondly, by putting a little spawn among the dung in melon or cucumber pits or frames; in September, when the crops are cleared away, as much spawn could be taken out as would give a plentiful supply during the following winter, with a sufficiency left in the frames or pits to produce a good crop, by keeping on the lights, by watering them if dry, and by covering with hay, which would give a supply until they were produced in the forcing-house. Thirdly, he would procure a supply by laying some well-dried horse-droppings in one of the shelves in the house in the summer, and spawning it afterwards, it would produce a plentiful supply. The best spawn was known by a sharp acid mushroom-like smell. He preferred the spawn that had the appearance of mouldiness to that which appeared like threads, as he considers when it is in that state its vegetative powers are partly exhausted. When spawning the bed, he lays small pieces in holes 2 in. deep and about 6 in. apart, then well rams it,

and allows it to remain a fortnight, when the spawn will have spread through the dung. About 1 in. thick of fresh dung to be placed over the whole, then covered with loam, the top spit of an old sheep pasture repeatedly turned over before using, if a little sandy the better; or the loam from an old melon frame, about 2 in. deep with the screenings, and 1 in. more of the finer sort, well rammed, but not made smooth or plastered, as water, when it is necessary to be given, would pass off too rapidly. The temperature of the house to be kept the first week at 55°, the following week at 58°, to increase it the third week to 60°, which is sufficiently high, unless mushrooms would be wanted in a short time, when the temperature may be raised to 70°, with a covering of hay 6 in. deep. He always used water the same temperature as the house, giving it often but a little at each time, when the beds by their dryness were observed to want it. When growing mushrooms in beds, he would prepare his dung in the same manner as recommended for the house, with the addition of a little fresh dung when making up the bed, with wood faggots at the bottom about 2 ft. high; the bed to run east and west with an angle of 45°, as the north will produce in succession after the south aspect; the dung, 18 in. deep, to be mixed up with about one fourth light turfy loam; when spawned, to be covered with straw, which may be removed on fine dry days.

Mr. Stanley considered mushrooms could best be grown in a humid atmosphere. He did not approve of such a high temperature as Mr. Shearer recommended. He saw a bed made in the usual way with well-prepared dung and horse-droppings, which was spawned on the 20th of November, and did not produce until the first week in April, from which a large supply was regularly gathered for a long time afterwards.

Mr. Fish considered the subject was well worthy the attention of gardeners, as he is aware that in many places it was found difficult to produce them. He has grown mushrooms abundantly by preparing in May equal quantities of horse-droppings and cow-dung; when well dried, to be spawned and then covered with littery manure; air and light to be admitted freely, by which they grow strong, and acquire a rich flavour. He saw spawn produced in melon frames in the way recommended by Mr. Shearer, which kept good for many years.

Mr. Stanley would recommend fresh spawn for general use.

Mr. Fish was certain that mushroom spawn would keep good for three or four years, but its vegetative powers are easily destroyed either by too much wet, or by too much dry.

Mr. Grover used spawn which was made four years, and produced an abundant crop. For making spawn he preferred sandy loam, cow-dung, horse-droppings, and a little road-scrappings. When sufficiently worked together, it is then formed into bricks; while soft, a few holes to be made in it to receive the spawn; when the bed is spawned, to be covered over 2 in. thick with any stiff loamy soil.

Mr. Thomas Keane used horse-droppings, loam, and cut hay, which, when well incorporated, were formed into bricks 10 in. long, 6 in. broad, and 3 in. deep, spawned in the usual manner, left twenty-four days before using, in a temperature from 60° to 65°. The same spawn was piled up in a dry loft, was used for four years, and the last bricks were as productive as the first. He has grown fine mushrooms on shelves, as recommended by Mr. Shearer, with the temperature of the house from 55° to 60°.

Mr. Wragg agreed with Mr. Fish, that mushroom spawn can be kept good for many years. He always made, at one time, a supply to serve him for four or five years. As variations of temperature would more or less affect it, he stored it in a back shed, with power to admit or exclude air according to the changes of the seasons.

Mr. Fish always kept the temperature of his houses at 60°, made excellent spawn, thoroughly impregnated in fourteen days, and has grown fine crops on dung beds in a vinery.

Mr. Grover considered open windows were necessary to give air every three

or four days to the house ; that gentle syringings every two or three days, and a slight covering of hay, were conducive to the growth of the mushroom.

Mr. Fish believed that the nearer we imitated the works of nature, the more successful would be our operations ; and that the more substantial a bed is made, the more juicy and better would be the produce.

Mr. Caie agreed with Mr. Fish in the observations just made, and in reference to that subject, he always observed that mushrooms were found more plentifully after rain, and that showery after warm weather was the cause of producing them. He has grown mushrooms on shelves, by filling them in succession with well-prepared dung, and spawned, by which he produced a regular supply nearly all the year round. He has known gentlemen's places where the gardeners rarely succeeded in growing mushrooms.

Mr. Massey considered any adhesive soil fit for making the brick, but would give the preference to loam. He always made the best spawn with horse-droppings, cow-dung, and loam ; he has kept it for nine years. He always observed the new spawn, when used, to run quicker ; and that an increase of temperature was necessary to excite the old, which he found as productive as the new. When the bricks were formed, and while soft, he made holes and inserted small pieces of spawn, which very soon impregnated the whole. He did not think that Mr. Shearer, however anxious he might be to obtain mushrooms, would succeed by raising the temperature to 70° ; he never allowed fire heat to raise his house above 50° or 55°. He was opposed to the admission of light, which he is sure is injurious to the mushroom.

Mr. Thomas Keane agreed with Mr. Massey in the advantage of excluding the light, and also with Mr. Grover in the benefit derived from syringing.

Mr. Stanley had preserved spawn for seven years, and was one season unsuccessful in growing them, although the bed was made with the same materials and attention as in other years.

A general conversation then took place, and from the answers given to the many enquiries made on the subject, the failure was attributed to a combination of circumstances which cannot always be controlled by the best practical gardeners.

Mr. W. Keane believed, from his practice, and which was generally corroborated by the observations that were made by the members who preceded him in the discussion, that mushrooms are best grown in places excluded from the light, and then detailed the practice adopted by the growers in the neighbourhood of Paris, who supplied the market during the whole year with mushrooms grown in quarries, where the same beds served for many seasons, with the addition of a little fresh dung mixed three or four inches deep, to enliven the bed for the spawn the better to work. He also agreed with the opinions so generally expressed, of the advantages of gentle syringings to create a dew, which, by its genial influence, is certain to increase the supply.

Mr. Shearer, in his reply, entered at length into a full explanation of all his practices, as detailed in his paper.

ART. VI. *Retrospective Criticism.*

MOISTENING the Air of Hot-houses by Steam. — In p. 189. I find an article on "Moistening the Air of Hot-houses," by T. Appleby, dated February 15. 1840, in which he states that he had admitted steam into the orchideous house for nearly two months. If so, he must have commenced its admission about the middle of December, at which period I should have thought such treatment would have been injurious to the plants, as tending to force or excite them too prematurely. In this, however, I may be wrong ; but I never admit the steam, much moisture, or increase the heat in the house beyond 65° or 70°, until the beginning or middle of February, according to the state of the weather ; I merely mention this circumstance, as

probably an error in the periods may have occurred. I wish Mr. Appleby had given some information respecting the size, shape, and dimensions of his boiler. The weight, 80 lb. "with taps included," does not convey any idea of either; neither does he give the size of his house. These particulars might be of considerable advantage to any person wishing to pursue the same mode of treating their plants.

I therefore take the liberty of giving you the manner by which I create a humid atmosphere for my orchideous epiphytes; fully aware of the advantage they derive from this system, in every instance save one; and in that particular I must take the liberty of differing from Mr. Appleby. I do so with great diffidence, and with the hope that he may be induced, by some future remarks on this subject, to enable me to overcome the only difficulty and imperfection which I conceive exists in the admission of steam.

To quote Mr. Appleby's words, "The most delicate flowers are not injured, nor their duration shortened." I unfortunately have found that several flower-buds have been so injured as to turn quite yellow and sickly, and drop off a few days before they ought to have expanded. This has occurred with the *catasetums* and *cattleyas*, and several of the *oncidiums* have had "their periods of duration shortened." The same injury has occurred to some stove plants, which I introduced amongst the epiphytes. This I now remedy by removing the flowering plants at a proper period to a dry house. On the other hand, there are several which do not appear to be affected by it. At the same time that I regret this, I am well repaid by the rapid and luxuriant growth of the plants, and by the number of pseudo-bulbs they have and are now forming. Those plants which two years ago were small, weak, and sickly, have now become large and healthy, and have thrown up three, four, and five shoots; and next year many of them will be what may be called fine specimens. Added to the modified steam they receive during a considerable portion of the night, particularly in warm weather, which may be said to be analogous, in a great measure, to their heavy native nightly dews, I frequently syringe overhead with tepid water, generally twice a week, and sometimes oftener. This I am induced to do, as I find the material in which they are potted is not much affected by the steam, being only superficially moist.

My plants are placed on platforms of white Yorkshire flags, and the pots are packed round with flakes of fresh moss, which gives the house a very pleasing appearance, and retains a great deal of moisture. The flags also absorb much of the water used in syringing, and keep up a constant humidity, particularly in warm weather, by gentle evaporation, which is grateful to the plants. I would recommend Mr. Appleby to introduce a plant of the *Coffea occidentalis* (*Tetramèrium odoratissimum Spreng.*) into his house; it seems to thrive particularly well in that atmosphere, and its rich and luxuriant dark green foliage is highly ornamental.

It is now three years since I put up a steam boiler, attached to a small pine-house, and having experienced the decided advantage derived from a humid atmosphere, in swelling off the grapes and pines, as well as the healthy appearance, cleanliness, and growth of the few stove-plants in the house, I placed a boiler to every house except the green-house. In February, 1838, for the same reason given by Mr. Appleby, to create a moist atmosphere in the orchideous house, which is 22 ft. long, 12 ft. wide, I attached a boiler to it.

The boiler is of metal 2 ft. 6 in. long, by 2 ft. wide, 1 ft. 3 in. deep, and $\frac{1}{2}$ in. thick, inside measure; and it diminishes 2 in. from top to bottom on the four sides. The flange round the boiler projects $2\frac{1}{4}$ in.; the cover is flat, and $\frac{1}{2}$ in. thick, with the usual holes, which I drill in the situations best suited for the safety-valve, steam-pipe, supply-pipe, and gauge-cocks. There is also a hole cast in the centre of the lid 8 in. by 4 in., oval in form, to clean out the boiler when requisite. The cover is fastened on the flange of the boiler by bolts and nuts, and the joining made good with iron cement, composed of borings of metal, sulphur, and saltpetre. This makes the boiler steam-tight.

The boiler is set over the fire which heats the house (as I continue to

prefer the smoke-flue), and the steam is admitted into the house by means of a stop-cock at pleasure, or to whatever extent is deemed desirable. There is a damper in the flue, which in hot weather, when the moisture is particularly desirable, turns off the fire and prevents it circulating through the flues, and increasing the temperature of the house. At other times, the fuel required to heat the house boils the water, the steam from which, if not admitted into the house, escapes through the safety-valve.

There is a shelf of Yorkshire flag in the front of the house, one foot wide, supported on inch-round iron bars; and under this shelf, near the front edge of it, runs the steam-pipe, perforated at every foot with small holes, less than $\frac{1}{16}$ of an inch. The pipe is inch bore. I first used a lead pipe, but soon found the expansion and contraction so great, that it got out of shape, and occasioned so great a lodgment of condensed vapour in various places, as to rather impede the entrance of the steam. I then substituted the gun-barrel gas-pipes, and find they answer admirably.—*John Lyons. Ladiston, Mullingar, May 26. 1840.*

The Construction of Mr. Penn's Hot-houses.—From some expressions in our account of Mr. Penn's mode of heating and ventilating (p. 120—128.), it has been thought that it was not requisite to have either the sloping sashes of the roof, or the upright sashes of the front, to open. A very little reflection, however, will convince any one that Mr. Penn's mode of ventilating can only be effective while artificial heat is being applied; and, consequently, that in houses heated by his mode, as well as in all other houses heated artificially, provision must be made for ventilating during the hottest summer months, when artificial heat is not wanted. From this, it will, we trust, be clearly understood, that Mr. Penn's mode of warming and ventilating requires no deviation whatever from the usual mode of constructing the roofs, fronts, and ends of hot-houses.—*Cond.*

The Elton and Black Eagle Cherries. (p. 264.)—The Elton is a very fine cherry, and deserves a place in every gentleman's garden; but as to the Black Eagle, another of the cherries raised by the late Mr. Knight, it is not a merry (merise), certainly, but it is, notwithstanding all that has been said to the contrary in your Magazine (p. 264.), a small cherry: nor, though small, is it good; for a poorer, more vapid fruit was never produced. It is, however, a free-growing tree and a tolerable bearer. I have both the Elton and Black Eagle in my garden, near Liverpool, and the account I give of their qualities is the result of experience.—*T. R. Liverpool, May 28. 1840.*

When matters of this kind are related by a correspondent who does not give his name publicly, he ought at least to give it to the conductor confidentially.—*Cond.*

ART. VII. *Queries and Answers.*

A CLOTHY Substance, white above and greenish beneath.—I take the liberty of sending you a specimen of a curious natural production, which has been this year found covering some meadows, near an estate of Lord Radnor's in Berkshire. It was found on the receding of the waters, after the long-continued floods of last winter and spring, on some meadow land near Lechlade and Fairford in Gloucestershire. The quantity covered in one large mass, without any interruption, was as much as ten or twelve acres in one piece. No such appearance has ever been seen or heard of before, though the same land has been flooded almost every year. The substance was so adhesive that the farmers tried ploughing and harrowing it but in vain; the only way of getting rid of it was by pulling it off like a plaster. As many as four or five meadows have been covered with the enclosed clothy substance, and what is singular is, that some of these meadows had not been under water any part of the winter. A somewhat similar substance was said to have fallen in a field somewhere in Prussia last year, and I saw a specimen of that. It was very like the

enclosed, but not so thick, and of a greyish colour. This material is so thick, that a gentleman, a neighbour of Lord Radnor's, has had a waistcoat made of it. The specimen sent has been taken from the ground for above six weeks. Any information you can give me respecting this singular production will be most thankfully received. Small pieces of the filmy white scum have often been found in the low lands and ditches in the same neighbourhood, but nothing at all of this kind. The green side was next the ground. — *L. R. Grosvenor Street, May 30. 1840.*

The substance sent was about 6 in. square, and a quarter of an inch thick; white and cottony above, like a piece of fleecy hosiery, and on the under side green, exactly like fresh conferva, with some withered blades of grass and other extraneous matters mixed with it. This green side was evidently that which had been next the surface of the ground, and the grass, &c., had adhered to it when it was torn off. The upper side had become white, in consequence of being bleached by the sun, as is frequently the case with the conferva on the sides of ditches and ponds, during summer, after the water has been some time drained out of them. We sent a specimen of this substance to the Rev. M. J. Berkeley, and the following is an extract from his letter:—

“I am sorry that I cannot give you any very definite information on the substance of which you transmitted me a specimen. I have very frequently seen over meadows, after the floods have subsided, a coat of a similar substance, but not beautifully bleached as your specimen. I suspect that it is *Conferva rivularis*, which, when dry, scarcely differs under the microscope; but, if so, the mass cannot, I should think, have arisen from plants washed out of the main stream, but from individuals that have vegetated on the spot, the flood having probably been of long duration. I cannot say, however, that I have ever seen *Conferva rivularis* grow in such a situation; but I know not to what other species to refer it. I do not think there is more than one species of *Conferva* in the substance; but there are a few individuals of *Closterium*, *Vorticella*, *Gomphonema*, *Scenedesmus*, *Bacillaria*, *Oscillatoria*, *Fragillaria*, &c., but none in a very good condition. If I remember right, the substance found in Russia and Prussia consisted principally of those minute algæ which resemble infusoria.—*M. J. Berkeley. King's Cliffe, Warningsford, June 10. 1840.*”

Stock for the Moorpark Apricot; in answer to J. W. D., at p. 280.—Generally, throughout the county of Leicester, apricot trees, that are planted by the side of a dwelling, rarely die in that sudden manner I have witnessed them do in gardens. I have often felt humbled when passing these fine specimens, to think that we could not compete with them; the trees in our gardens dying yearly off by large branches, whilst theirs are annually producing fine crops, and the trees rarely dying, except from old age. These trees are pruned and nailed by men who in general can have but an imperfect knowledge of the constitution of plants. I have thought the cause of their dying in our gardens arises from a bruise; for gardeners of this sort are in general more careful with their trees than we are. There is not that straining and twisting exercised by them, to give the tree the artistical appearance which many of us of the “new school” think is requisite.—*W. Brown. Merevale, June 5. 1840.*

A new System of cultivating Frame Potatoes.—*Covent Garden Market.* Frame potatoes were plentiful enough, but owing to a new system of cultivating this universal and indispensable root, by planting them in the autumn in a peculiar soil, and keeping the beds warm by rich dung, and impervious to frost, the potatoes produced in frames are in less demand, and scarcely at a remunerating price, whilst those planted in the autumn are sold freely at 4d. or 6d. per lb., and pay well. (*Morn. Chron.*, May 25. 1840.) Can you or any of your correspondents give an account of the mode of culture above mentioned, stating what are the peculiarities of the soil referred to, and what the mode of keeping the beds warm by rich dung, &c.—*T. R. Liverpool, May 28. 1840.*

THE
GARDENER'S MAGAZINE,
AUGUST, 1840.

ORIGINAL COMMUNICATIONS.

ART. I. *Notice of a Visit to Eyewood and Presteign.* By J. B. W.

EYEWOOD, the seat of the Earl of Oxford, is about two miles from the town of Kington, near the northern confines of Herefordshire. In the days of its splendour this must have been a noble place, the house and every thing about it being on the most extensive scale; and at that time no expense was spared in keeping it in the highest order: for a number of years, however, the place has been gradually going to decay, the flower-garden having been planted with potatoes, the lawn turned into a hay field, and the park applied solely to agricultural uses. Yet, even now, there is an air of magnificence about it, which strikes one most forcibly when viewing for the first time the ancient-looking mansion, backed by a wooded hill, and surrounded by an extensive park, through which an avenue leads up to the boundary of the pleasure-ground, in the direction of the principal front. This pleasure-ground contains many fine evergreens, especially on the west side of the house, where they are massed and intermixed with water in the most picturesque manner. Attached to a part of the building there is a plant-house in the old style, from the front of which the water and trees above-mentioned have a beautiful appearance; the park also is overlooked, and several views of distant scenery obtained, from this and other parts of the pleasure-ground. The flower-garden (now about to be restored) was situated at one end of this green-house, and formed a termination to the grounds in that direction. A walk winding among shrubs and trees leads from the pleasure-ground to the extensive kitchen-garden, which is excellently situated both as to convenience and shelter, but, not having been regularly worked for many years, it will require much additional labour to bring it into a high state of cultivation. A long range of glass occupies the back wall of one of the divisions of the kitchen-garden. One of the houses is a late vinery; two are appropriated to pine plants, having vines trained to the rafters; and two are peach-houses, in which the trees are whitewashed with lime in the manner of Mr. Paxton at Chatsworth, noticed in a previous

number of this Magazine. The reason assigned by Mr. Ker for this practice is, that it causes the buds to break better, while Mr. Paxton whitewashes to ripen the wood. I think, however, that the only real good such a dressing can do, is to check the increase of insects, and it would probably be an effectual cure for the brown coccus, often so troublesome in peach-houses. Some of the wall-trees, as pears and morello cherries, are very good; others, as the apricot and peach, very bad; but in every place where I have been, with one or two exceptions, the peach trees look unusually ill, the last wet and sunless summer having imperfectly ripened the young wood, which, in consequence, gums and dies.

It appears to me that the evil influence of an ungenial season might in a great degree be counteracted by a proper formation of the border, by which the roots of a tree might be kept under almost as much control as its top.

Formerly it was, and frequently is even now, the practice in making wall borders, to take out or to trench the ground 3, 4, or 5 feet deep, and from 8 ft. to 12 ft. wide; and then, if the situation were low, or the subsoil wet, to make a single drain along the front, parallel to the walk. In such borders the trees grow and bear comparatively well, so long as their roots remain near the surface; in a few years, however, the roots begin to dive downwards, meeting with no obstruction, but rather encouragement (the best soil in trenched borders being at the bottom), and finding at all times an abundant supply of moisture; and the trees soon acquire a luxuriant, and consequently a sterile, habit, which the severe winter pruning to which strong-growing wall-trees are usually subjected, confirms and increases rather than restrains. Where a case of this nature occurs, it would be well to try the radical remedy of "cutting off the supplies," by taking the trees entirely up, and replanting them near the surface, carefully giving the roots as nearly a horizontal direction as possible; this, however, would only be a temporary cure, calculated to check redundant growth for a few years, but not permanently, as the roots would get too deep again if not prevented by a substratum of some impenetrable material, which it would then perhaps be impracticable to apply. Instead of those deep and narrow pits which defeat their own end, I would have the borders for peach, apricot, cherry, and plum trees 15 ft. wide; for pear or apple trees, 18 ft. In depth, no border, under ordinary circumstances, need exceed 2 ft. 6 in. at the wall, deepening with an even slope to 3 ft. at the walk; parallel to which, if the situation is low, or the subsoil retentive, a good tile drain should be constructed 1 ft. deeper than the bottom of the border, and filled up with rough stones, of which a layer 6 in. thick (covered by a few inches of leaves to prevent the soil from filling the interstices)

should be spread equally over the bottom of the border. Where the subsoil is dry, of course drainage is not necessary; and the layer of stones might be reduced to 3 or 4 inches in thickness, its only but highly important use being to prevent the roots from penetrating deeper than their assigned boundary. Again, in very wet situations, 9 or 10 inches of stones would be required to insure proper drainage, thus varying the relative depth of soil and stones according to local circumstances, the principle to be acted upon being to keep the roots of the trees near the surface, and comparatively dry. Such a bed of well-chosen soil (good strong loam, without dung) would be amply sufficient for the healthy maintenance of the trees; and the roots, having plenty of space for horizontal extension, would never, to any injurious degree, penetrate through the substratum. Deep digging must be avoided; the borders should therefore be cropped with shallow-rooting vegetables, such as lettuces, onions, turnips, &c.

The plan I recommend may, at first sight, appear troublesome and expensive, but ultimately it would be found the most economical, because from such borders a remunerative return of fruit would be obtained, and the after cost of renewing the trees would be much lessened. The premature decay of peach and apricot trees, which so frequently occurs, is in a great measure owing to the injudicious formation of the border they grow in, whereby a bad system of roots is first induced, and then imperfectly formed wood; the next steps are disease and death. In hot-house grape culture, too, seven tenths of the failures that happen arise from the same cause; for the vine, although a gluttonous feeder, dislikes more than any other fruit tree to seek its food in a wet medium. This subject is only lately beginning to be understood, but, on account of its great importance, it deserves the especial consideration of every gardener. *

Boultybrook.—A short distance from the town of Presteign, in Radnorshire, there is a remarkably neat little place, called Boultybrook, which some years ago was remodelled, if not entirely formed, by Sir Harford Jones Brydges, Bart., to whom the property belongs. The situation of the house is exceedingly well chosen, as it is placed in some open meadows which rise gently from the river Lugg; and, although in the vicinity of the bleak and barren Welsh hills, the place is so well sheltered that

* Since these remarks were written, I have read some very judicious directions for the formation of vine borders, in vol. xi. of the *Penny Cyclopædia*, article "Grape Vine." The writer there recommends a layer of concrete, "composed of powdered unslaked lime and gravel, worked together with water on the spot," to be first laid all over the bottom of the border; and after this is set, "the stratum of stones, to the depth of at least 6 or 8 inches, may be laid on. Some dried heath, or tough turf with the green side downwards, should be laid over the stones to prevent the soil from mixing with them."—*J. B. W.*

it is comparatively warm. One rather inconvenient arrangement is, that the public road must be crossed in passing from the mansion to the gardens, to which a walk, or rather two walks separated by a row of nut trees, leads through an orchard. The kitchen-garden is small, but well situated, declining gently to the south. Against the north wall there are two vineries, in which the vines have formerly been spread under the whole of the roof, but it is the intention of Mr. Weatherston (the very intelligent gardener) in future to adopt, as far as practicable, the method described several years since by Mr. Mearns, and which may be termed the successional system. By this method it is expected to obtain finer fruit, and also to admit more light into the interior of the house. Black currant trees, a novelty in the forcing department, have recently been planted in the earliest house, to be trained up the back wall.

At the bottom of the kitchen-garden, on the south side, are the pleasure-grounds, in a low and damp situation close to the river Lugg, besides which there are several small streams and a pond in the grounds. Close to the entrance from the kitchen-garden there are two hot-houses; the one a peach-house, the other a singular structure in which plants are kept. The chief part devoted to flowers is a very pretty group of beds directly in front of, but on a lower level than, the peach and green houses. These beds have lately been formed by Mr. Weatherston, who, as I am informed, has greatly improved the whole of the place. There is one great drawback, however, to the beauty of this little spot, and that is, some lanky poplars which stick themselves up between those beds and the houses, only a few yards from the front of the latter. Besides their ungainly appearance, these trees are injurious by shading the houses, and their roots must likewise impoverish the border of the peach-house.

A piece of ground close to the river side is now in the course of preparation for a fruit-garden; it is, however, by no means well adapted for such a purpose, being, from its low and damp locality, peculiarly liable to be affected by that greatest imperfection of our climate, the late spring frosts, which are invariably much more injurious in moist than in high and dry situations.

Sir Harford, with great liberality, grants permission to the inhabitants of the town to walk in his grounds, and I believe his kindness is never abused.

Herefordshire, Jan. 20. 1840.

ART. II. *Postscript to Mr. Herbert's Article on Cytisus Adami in p. 289.* By the Hon. and Rev. W. HERBERT, D.C.L., F.H.S., &c.

HAVING written to you hastily on the subject of the *Cytisus Adami*, or purple laburnum, and kept no copy of what I wrote,

I am not sure whether I stated, as I should wish to have done, that, in the case which I suppose, of a hybrid bud proceeding from the joint operation of the cellular tissue of two woods brought into intimate union and contact by any sort of grafting, it may naturally be expected that the hybridity should be less indissoluble than in the case of a hybrid produced from cross-bred seed; because the two sides of the bud may severally have received more of the influence of the wood to which they were most nearly approached, while the centre of the bud might perhaps partake more of the joint types. That view of the subject would account for the anomalous habit of this *Cytisus*, in throwing out fertile branches which nearly revert to the respective characters of the two parents, while a portion of the tree continues to be hybrid and sterile. In recommending to gardeners to make experiments with a view to produce such curious artificial results, and to verify my theory, I should wish them to lacerate the edges of the graft or piece inserted by budding, as well as of the stock, so that the cellular tissue of the two plants might become not merely united, but absolutely intermixed and blended together, at the line of union. The wood must be then teased into breaking from that line, by rubbing off all buds that appear elsewhere. Of course it would be advisable to try the experiment first with such plants as break most readily from the hard wood. It appears to me possible that a cross between the olive and privet might be so obtained, which probably could not be effected by a seminal cross; or of such a sterile plant as the double yellow rose, with some other species or variety.

London, May 20. 1840.

ART. III. *Further Remarks on the Cytisus Adami*. By the Hon. and Rev. W. HERBERT, D.C L., F.H.S., &c.

I HAVE received your note, enclosing M. Poiteau's letter with reference to the papers in the *Ann. de la Soc. d'Hortic. de Paris*, relating to the *Cytisus Adami*. I perceive that M. Prevost conceives the original shoot of *C. Adami* to have proceeded from a preexisting aberration of *C. Laburnum*, which sent an anomalous shoot through the graft of *C. purpureus*, a supposition repugnant to all that we know of the process of vegetation. M. Poiteau having, in 1830 (vol. vii. p. 95.), published M. Adam's statement, that the branch issued together with some shoots of *C. purpureus* from the bark of *C. purpureus*, round a bud inserted in *C. Laburnum*, which had perished or remained sulky for a year; that he had sold the original plant before it had produced flowers, together with others grafted from it; and that it no longer existed in his garden; M. Camuzet (vol. xiii. p. 196.), in 1833, visits the original plant in the garden of M. Adam, at

Vitry, after his death, examines it, and is satisfied that even to its roots the stock is *C. Adami*, and not *C. Labúrnum*; and asserts thereupon that it was a mule from seed, and that M. Adam must have been mistaken in thinking the shoot had proceeded from the graft. No reliance can be placed on this conflicting statement. M. Camuzet has furnished no proof of the identity of the plant he examined, nor even of the inference he draws, for he does not say that the stock had any branch below the graft; and its supposed difference from *C. Labúrnum* could have been only perceived in the appearance of the bark, which is not satisfactory. M. Leclerc Thouin's observations are not directed to this *Cytisus*, but to a monstrous orange differing from the fruit of the plant from which the graft was supposed to have been taken. He supposes that vessels of cellular tissue, in lateral contact with each other, may be filled with the sap of the two different varieties separated by the most slender partition, and the sap of the one modified by passing into the other. It will be seen by the original words which I have subjoined in a note*, and which form the only sentence directly to the point, that M. Leclerc, speaking of mathematical surfaces with reference to such a subject, does not make his meaning very distinctly intelligible; but, as far as I can understand it, it does not seem to militate against my supposition, and I see nothing in the papers to which I am referred which should induce me to alter it.

It is known that a bud proceeds from the cellular tissue of the plant. It must therefore originate in the juices within the cells, or in the juices between the cells, or in both. Whichever of the three be assumed to be the true fact, I see no reason why the two woods united by insertion may not operate jointly to produce a bud, and, if they do so, the produce must be expected to partake of their joint peculiarities. Taking it to proceed from the juices within the cells, it is certain that cells may be confluent, and their contents in progress become mingled in some one cell, because, unless two lacerated or cut cells could unite, no nourishment could be given to the piece inserted; and, if two half cells can grow together, their contents can be mingled, and the cells proceeding therefrom will partake of a joint origin. Taking the bud to proceed from the outward juices pervading the interstices of the cells, the combination of the two fluids, so as to produce a joint result, is still more easy; and, if it

* "Il devient facile de concevoir que la matière organisable soit absorbée également et assimilée différemment dans deux vésicules voisines, alors même que leurs parois se seraient en partie sondées; que la sève de l'une se modifie en passant dans l'autre, et que la différence spécifique apparaisse nettement tranchée du deux côtés d'une double cloison, si minée à nos yeux, que nous pouvons presque la considérer comme une surface mathématique." (Vol. xviii. p. 303.)

is possible in either case separately, it is equally possible if the bud be considered as proceeding from the juices without and within, or even from the very substance of the cellular partitions. But it is certain that the sap is not *modified* (as M. Leclerc supposes) by passing from the cells of one wood into those of the other; on the contrary, it conforms itself in all usual cases of insertion to the nature of the wood through which it last passes, so as to produce that wood unchanged in its growth and progress. My reason for giving credit to M. Adam's assertion with respect to the origin of this curious plant is, that we have had no instance of a hybrid from seed resolving itself in the course of its growth into its component and fertile elements, nor of any mule, either animal or vegetable, becoming (either altogether or in part) more like one of its parents than it was in the form first assumed after its perfect developement.

London, May 29. 1840.

ART. IV. *On pulverising Soils, as a Means of improving them.*

By JOHN FISH.

THE fertility of adhesive soils becomes greatly increased by frequently exposing them to the atmosphere, by which means they become so much pulverised, as to encourage the growth of the fibres of plants. One cause of the unproductiveness of adhesive soils is, that air cannot penetrate to the seeds or roots of plants; preventing the germination of the former, and the future wellbeing of the other. In such cases, the roots of plants can receive no advantage from the carbonaceous matter which exists in the atmosphere, from the decomposition of animal and vegetable substances on the earth's surface. Another cause of unproductiveness is, that such soils cannot retain a sufficient quantity of moisture, but are saturated upon the surface at one time, and burnt as hard as a brick at another.

In the former case, the fibres of plants are generally rotted, whilst in the latter they are torn in pieces by the cracks in the ground. The moisture will neither sink freely, nor rise freely, when the sun has evaporated the moisture on the surface. Again, in such soils the full advantage of manure cannot be realised, as it must be within the reach of the atmosphere before those changes can be effected, by which alone it can become the nourishment of plants. Hence the importance of trenching, ridging, and frequent digging, by which a large portion of the soil is exposed to the atmosphere, and rendered more friable and open in its texture. These operations may be performed as soon as the ground is clean. The depth will depend upon the nature of the soil and subsoil: strong soils can scarcely be dug or

trenched too deep; nor indeed can any soil, unless the subsoil contains something noxious to vegetation.

Pulverisation ought to go on during the process of vegetation, by the free use of the fork or hoe. In summer such operations prevent the soil getting dried up, as evaporation proceeds more rapidly from a hard surface than a loose one. It is some time before water can penetrate a hard surface, upon a loose one it sinks to the roots at once. The more soil is stirred among crops of any description, the more fibres will plants produce, and this increase of strength to the plants will more than pay the labour. Independent of the neat and orderly appearance of the drill system among culinary vegetables, it possesses the advantage of enabling us freely to stir the soil: for this purpose I consider a three-pronged fork preferable to a hoe, as by using the latter the ground gets hard below. Believing pulverisation to be of great importance for loosening the texture of strong soils, enabling the fibres of plants to run in all directions in search of food, imbibing and imparting a sufficiency of moisture, without receiving too much, or retaining it too long, and also as tending to eradicate deleterious properties in the soil, I should wish to see it more generally adopted, and extended to the cultivation of many of our field crops.

Exotic Nursery, King's Road, May 18. 1840.

ART. V. *Description of an Instrument used for taking the Heights of Trees.* By H. W. JUKES, Esq.

IN the autumn of 1836 I spent several months at Studley Royal, in Yorkshire, the residence of Miss Lawrence, making portraits of trees for the *Arboretum Britannicum*. As these portraits were all drawn to a scale, it became necessary to measure the trees; and their heights were taken with the instrument or machine of which *fig. 47.* is an outline, to a scale of a foot

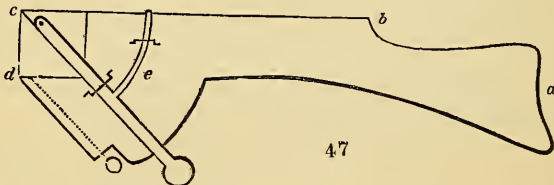

to an inch. This instrument consists of a thin board of oak, 2 ft. 9 in. long, shaped like a gun-stock, the end *a* being adapted for the shoulder, the muzzle or line *b c* for taking a sight of the top of the tree, and the square, of which *c d* is a side, being marked or cut on the board at the farther extremity. The

length of the side of this square is 4 in. A diagonal line is drawn across from the angle *c*; and parallel to this line, a brass pendulum is suspended from a side pin. This pendulum has a curved limb or finger *e* attached anywhere near its middle; and the pendulum and curved limb are kept from flying off the board by two brass guards, which, however, admit the free action both of the pendulum and curved limb. At the extremity of the muzzle *c*, a sight is fixed, as in the barrel of a common fowling piece, to guide the eye; and the but-end of the instrument being applied to the shoulder, and the sight on the end of the barrel part directed to the top of the tree, the operator advances towards it or retires backwards till the point of the curved limb is visible above the line of the stock, as in the figure. The circumstance of the curved limb being visible above the barrel part of the instrument, proves to the operator that the plumb line rests on the diagonal line of the square, and consequently that the angle made by the eye of the operator with the top of the tree is 45° . The distance of the operator from the tree, and the height of his eye from the ground, being then added together, give the height of the tree; unless the ground should not be level, in which case allowance must be made, either by adding or subtracting, according as the ground may be lower where the operator stands than at the root of the tree, or the contrary.

This instrument, I believe, was invented by Mr. Cuthbertson, the head gardener at Studley Royal, who was my constant assistant in taking the measurements.

It has occurred to me, that the same principle might be exemplified in a more portable instrument, and I have accordingly contrived *fig. 48.*, which is only 12 in. long on the upper side. It is made of box, with a brass octant suspended from its centre, and loaded at the extremity, with a curved limb, as in *fig. 48.* It is unnecessary to describe the manner of using it, which is pre-

cisely the same as that of the preceding figure.

London, May, 1840.

ART. VI. *On the Decay in growing Larch and Spruce Fir Trees.*
By J. WIGHTON.

YOU have often taken notice of the decay in larch and spruce fir trees, commonly called the rot, and invited opinions as to its

cause. As nothing satisfactory has been discovered on the subject, I venture my opinion, which is, that this decay proceeds from the too rapid growth of the trees when young, and from their very slow growth when aged. In confirmation of my opinion, I have sent you specimens from decayed, and also from healthy trees, taken from the trunks and from the roots.

When larch and spruce firs are young, they grow often rapidly, and the wood formed at that period is very porous both in the trunk and roots. As the trees advance in age, the supply for their growth is less, from the soil being greatly exhausted, and often from the trees not having been thinned out in proper time. The outer case of wood then formed is less porous, and becomes in time too compact to admit air to the early formed wood within. This latter being of a coarse grain, the dry rot begins to infect it, in the same manner as it attacks wood which has been painted in a green state, the paint excluding the air from the inside wood. The specimen No. 1., taken from the root end of a decayed larch, is an example.

The decay in the trees goes on more or less rapidly, according to the grain of the wood. It ascends the trunk and makes its way along the roots; at least those first formed which have become the conducting tubes to the trunk from the smaller roots and fibres. As the disease advances, the sap collected in the fibres passes with difficulty through the decayed conductors to the trunk, and the trees become sickly, although the small roots and fibres where the sap accumulates be healthy. This will be evident in the root specimen No. 1., cut off 1 ft. from the bole of the tree. As farther proof that decay proceeds from too quick a growth, the trees that have grown beside decayed ones, but happened to grow slowly, have been found sound; and it may often be observed, in trees partly decayed, that it is the quick growths in the trunk that are rotten. Specimen No. 2. shows the former, and No. 3. the latter.

Decay may, in some cases, have proceeded from other causes; when trees make unusually large growths, as in specimen No. 4., such wood cannot last long. In this specimen, however, the outside wood is of fine grain.

The supposition, that the soil is the cause of rot, is in a great measure correct, if climate be taken in conjunction with soil. It is a common observation, that a tree has got down to a soil which it does not like. If the soil were in fault, the wood grown then would be bad, whereas in reality it is the best. The error lies in the supposition that the decay proceeds in age from soil and climate; but its foundation is actually laid in the youth of the tree. In proof of this, it is a known fact that trees grown in cold and barren situations are always sound. Their growths are small, and the wood in consequence is durable. The best larch,

for instance, in Britain, is grown at Dunkeld. The Athole frigate was built of it, and has well proved its durability. Those grown among the rocks are the soundest. When they were planted, there was hardly soil enough to cover their roots, but their foliage annually falling and decaying in crevices of the rocks, formed sufficient soil for them; and the supply increases as they advance in age. Larch grow there as in their native Alps. To this it may be objected, that the oldest larches in Britain, viz. those at Dunkeld, grow in garden soil, as do other fine trees in various places, especially in North Britain. For instance, at Melville House, Fifeshire, there are or were some fine larch trees growing on good land; and at the Whim, Peeblesshire, there are fine healthy spruce firs on wet bog soil. As these trees must have made strong growths, they may appear to offer a direct contradiction to the above statement, namely, that overgrowth in youth and undergrowth in age combine to cause the rot. It must be considered, however, that the aged trees at Dunkeld were kept when young as green-house plants, and probably stunted, so that they formed small-grained wood at first. Though they made large growths afterwards, the trees grew apart from others, and were not robbed of their supplies, so that it is most probable that their outside growths are in the same proportion as those of the inside. The same will apply to the other two cases mentioned above; and, so far from their being at variance with my theory, it was from having observed them that I was led to its adoption. Still it may be alleged that trees grow thick together in their native forests, and yet produce the best wood. This is true, but it must be remembered that the trees are in their natural climate, which is much colder than ours, and, of course, make slow growths. Those made while the trees are young are often the smallest, reversing the growth of our climate, where the trees that have grown quickly when young, are often starved in their after growth. This is not the case in natural forests, where trees find abundant nourishment from the mass of decayed vegetable matter which falls from the trees, and is not swept away like that in artificial plantations.

From the rot being more prevalent now than it was formerly, it has been supposed that the trees are of a different kind from those first planted. It has been said that they came from North America. This I do not believe; but, if it were true, it is not probable that they were natives of colder regions than those first planted here, and if so, they would not produce wood of coarser grain, or more likely to decay. If there are some varieties raised in this country from the original stock, they would be more likely to become naturalised here, and would perhaps stand better than the original trees; yet it is a well-known fact that some of the progeny of the ancient trees have

been infected with the rot. The question then is, how comes it that the disease has been on the increase of late years? One thing to be considered is, that there have been more trees planted, especially larch trees, and less care has been taken of them, than formerly. The trees are often left thick together, to form cover for game, the soil in consequence soon becomes exhausted, and the thinning at last comes with a vengeance, but too late. Another question is, why fir trees die when they become hollow, whereas many other trees live to a great age as hollow as a drum? The case of the firs is, however, different from that of their hollow neighbours; their disease being internal, both in trunk and root, while other trees often grow hollow from some external injury to branch or trunk, which does not affect their roots, so that they often grow vigorously while their rind and bark continue sound.

If I am wrong in the opinion that the rot proceeds from the external wood excluding the air from the heart or inside of the tree, at least there can be no doubt that the seeds of decay are first sown by too rapid growth; and little do planters think, when they admire the great progress of their young firs, that such rapid growth is but laying the sure foundation for trees rotten at heart.

Cossey Hall Gardens, April 1. 1840.

ART. VII. *On grafting the Acàcia.* By JOHN BREWSTER, Gardener to Mrs. Wray.

I HAVE often lamented to see the dwarf, delicate, but still beautiful, species of *Acàcia* struggling for life among their more hardy and robust brethren, and especially when the desirable object of placing them in a situation calculated to show their humble beauties to advantage, and impart to them a more hardy and robust constitution, is so easily obtained by grafting. This operation may be performed in almost any situation. Perhaps the best stock would be *Acàcia affinis*, owing to its rapid growth, and to its being hardier than any of the rest. I have known this species grown out of doors (from seed) to the height of 17 or 20 ft. in three years!

What a magnificent object a tree 20 ft. high, grafted with perhaps fifteen or twenty species, including *A. pulchella*, *A. diffusa*, *A. cyclops*, &c., would be! The great diversity of their splendid foliage, intermixed with their beautiful flowers, would form an object truly grand.

By choosing a strong stock, and planting it out of doors in the early part of May, and then, as soon as it had taken root, grafting it, cutting it down to within a few eyes of each graft; or,

if it can be conveniently done, inarching it, a fine tree would be formed in a very short time.

The scions may be put on of almost any size, even a large plant. Smaller plants may be grafted or inarched either in the stove or green-house. The plants that are grafted out of doors I would recommend to be potted in the autumn, in order to give them a little protection in winter; again planting them out in spring; and by continuing this system for two or three years, the grafts will become fairly established, when they may be left out all winter, with a good covering of mats in frosty weather.

If the above hints be thought worthy the attention of any of the numerous cultivators of this beautiful genus, I will yet hope to see the pendulous, dwarf, and delicate species attain the first place as ornamental plants, which they so richly merit, both in the green-house and pleasure-ground.

Oakfield, Cheltenham, June 13. 1840.

ART. VIII. *Notice of a Plant of Cereus grandiflorus, at Eatington Park, Shipston on Stour.* By W. HUTCHISON, Gardener to E. J. Shirley, Esq., M.P.

I SEND you an account of a plant of *Cereus grandiflorus* now in flower in the pine-stove here. It is a mistaken notion, that the night-flowering cereus, as it is commonly called, only flowers at 12 o'clock at night, and is off before the following morning. The plant here covers a trellis on the back wall of the pine-stove 7 ft. by 6 ft. Yesterday evening, at 8 o'clock, there were fifteen flowers fully out at one time. It was one of the most magnificent sights imaginable. It filled the whole house with odour; indeed, so strongly is it scented, that you can smell it before you open the door of the house. It is rather singular that for three successive seasons the number of flowers has been the same, viz. 21.

The soil used is very light sandy loam, if loam it can be called, as there is very little in it but sand. From August to February very little water is given; as the spring advances, it is given more freely. When the flower buds appear, water is given very plentifully, and the buds swell fast and expand in all their glory.

Eatington Park, June 13. 1840.

ART. IX. *On the Causes of Canker in Fruit Trees.* By JOHN JENNINGS.

I BEG to offer a few remarks on the canker in fruit trees, but more particularly in the pear tree. I have been endeavouring to learn its cause, with a view to exterminate it if possible; and, from the observations I have made, I am led to conclude that it is

not the ungenial soil, as is generally supposed, which is the sole cause of canker, but I think the *Stromatosphæria múlticeps Green* is the principal cause of that disease. I trust the enclosed shoots of pear tree, which are of one and two years' growth, in addition to those sent before, will enable you to trace it from the beginning to the end, that is, until it has from its first growth underneath the cuticle destroyed the whole of the layers of the bark, and, consequently, the branch. How, or by what means, it gets underneath the cuticle, I cannot pretend to say; but I think it possible, and even probable, that the sporidia may enter the pores of the epidermis. But I wish it to be understood, that, when I say it is the fungus which is the cause of canker in the pear tree, I do not mean to assert that it is the cause of every species of canker; for I believe there are other species of fungus that cause other species of canker. For instance, there is a kind of canker very prevalent amongst apple trees that has the same effect on them as the *Stromatosphæria múlticeps* has on the pear tree; that is, their branches die towards their extremities, more particularly the young shoots. The above-named fungus seems to thrive much better on some varieties of pear tree than on others, amongst which are the Windsor, the jargonelle, the summer and autumn bergamot, and swan's egg. I have seen a tree that had been grafted with two kinds of pears, and one of them was the autumn bergamot, which has suffered very much from canker or fungus growing upon it; the other kind is not hurt half so much: but, wherever it appears, it soon spreads itself on almost every variety of pear tree, should the season prove favourable to its growth; and the last season appears to have been one of this kind. The circumstances in which I am placed at present will not admit of my using any means that may suggest themselves for its destruction; but, were I to give my opinion as to the best means of destroying it, I should say, use the knife very freely, and then give a good washing with caustic lime water, at the same time cleansing the tree of all loose and decayed bark; I should then apply a liquid composition, and, perhaps, that of Forsyth would be as good as any.

I hope that these remarks may induce some of your abler correspondents to investigate the subject further than I have done.

Shipston on Stour, April 10. 1840.

ART. X. *Some Account of a Method of growing and preserving New Potatoes for a Winter Supply.* By AMAZIAH SAUL.

I AM not aware that the following method of growing new potatoes for a winter supply has been published in the *Gardener's*

Magazine. I am induced to make this communication, in consequence of having been in several gardens, and never, till I came here, having seen it practised. I think it well worthy of a trial, as it is well known to be a desideratum, in large families, to obtain a supply of this useful vegetable, in a young state, during as much of the season as possible.

This method, as far as I can learn, was first practised here by a person of the name of Job, whom I succeeded as gardener.

The kind of potato cultivated is the Irish red, a very good kind of late potato, and it succeeds well planted in the autumn. To have them ready for use in October, they should be planted about the middle of July. For the principal crop for winter use, the first week in August is the best time for planting. They should be planted on a good rich border, the drier the better. I have generally planted them in rows about $2\frac{1}{2}$ ft. apart, and about 1 ft. distant plant from plant.

It is necessary to place the rows a good distance apart, in order to insure good foliage by freely admitting the rays of the sun, as well as a free circulation of air among the leaves, &c.; as, in my opinion, the quantity as well as the quality of the crop depends much upon a proper attention to this point; and it probably might be better attained by placing the rows 3 ft. apart.

Potatoes planted in August will be ready for the table in November; and will continue good from that time till April, at which time it is easy to have a succession from those planted in the spring. The only extra trouble attendant upon potatoes when planted at this season is, to cover them in winter with leaves, or any other material which will keep out the frost. They must be taken up only as wanted for the table.

When potatoes are thus managed, any person may insure a supply through the winter, of almost as good a quality as those grown during the summer months. The only difference that I can perceive is, that those planted for the winter are rather more waxy than those raised during the summer; and with many this would be considered an additional recommendation.

It is necessary that potatoes intended for the autumn planting should be of a late kind, should be kept in a cool situation till the season of planting, and also be kept as clear as possible from sprouts.

Castle Hill, Southmoulton, Devon, June 22. 1840.

ART. XI. *On Apiarian Societies*. By J. WIGHTON, Gardener to Lord Stafford, Cossey Hall, near Norwich.

OF late years the keeping of bees has fallen into gradual neglect among cottagers. Apiarian societies have recently been

established in various parts of the country, to encourage the revival of the practice. Sundry causes may be assigned to account for the cottagers giving up the keeping of bees. First, the remarkable fact that for several years past we have had long cold springs, which have discouraged many from attempting to keep bees; secondly, many tracts of waste lands having been brought under cultivation has sensibly diminished the favourite wild flowers of the bees; thirdly, the low price which cottagers have been able of late years to obtain for their honey has operated most naturally as a discouragement; and fourthly, the quantity of honey imported from foreign countries has of course lessened the demand for that of native production.

It is an interesting consideration, how far apiarian societies can remedy the effects of these various causes. The first stated is the most serious obstacle to bee-keeping; and over that these societies can have no control. We can only hope that our old-fashioned genial springs may be permitted to return. Nor can the societies procure the waste lands to be again untilled. These lands are rendered far more profitable to the community, than they were when producing wild flowers for bees. It must be remembered, however, that the waste lands produced food for bees in autumn only, they being deficient of spring flowers; and their loss is in some degree made up by the greater number of flowers now cultivated. The operation of the third cause can be prevented, if the wealthier classes can be induced to make more use of honey. It was in much greater esteem among our forefathers than it is at present; and, if apiarian societies exert their influence, they may persuade the higher and middling classes to consume more honey in their families, by which the price will be advanced. Formerly the cottager sold his honey to the gentry in his neighbourhood; now he must depend solely upon the druggist or apothecary to purchase his produce, who is sure to give him a low price, knowing that the poor man has no other market. He will undervalue the honey, upon the pretence of the cheapness of foreign honey, the importation of which has been stated as the fourth cause of the discontinuance of bee-keeping among cottagers. It is true that some imported honey of a bad quality is sold at an inferior price; but the good brings double the price which the druggist will give to a cottager for native honey equally good; and for pure honey in the comb, the cottager receives only about one third of the price at which it is retailed in the shops. This might be remedied, if the societies were to appoint agents to collect the honey of the cottagers, and carry it to a better market.

In this county of Norfolk, an apiarian society is about to be established through the exertions of Mr. Hart of Billingsford, and a few other gentlemen, who have done much to encourage

cottagers to cultivate their gardens instead of sleeping away their spare time, or spending it in places ruinous to themselves and their families. Those gentlemen who encourage apiarian societies will render valuable assistance to their cottagers. Formerly they cultivated bees to their profit, and we hope to see them do so again. The keeping of bees would prove also a source of pleasure, and the interest they would take in observing the habits and industry of these insects would often divert their minds from heavier cares.

Cossey Hall Gardens, December 26. 1838.

ART. XII. *On Honey.* By J. WIGHTON.

THE popular name of virgin honey, as applied to that which is taken from hives on the depriving system, and from late weak swarms on the destroying plan, arises from an idea, prevalent among old bee-keepers, that the purest honey was to be obtained from a swarm thrown off by a swarm of the same season, and whose queens they believed to be virgins.

No brood being in the combs of such hives is, however, to be traced to very different causes; for late weak swarms from old stocks, provided they be thrown off at the same date, are equally without brood combs, and contain as pure honey as those erroneously called virgin hives.

When a late swarm is thrown off, be it from an old or a new stock, the season is past for the production of brood, while the weakness of the swarm is a still more powerful reason for its non-appearance, the number of bees not being large enough to keep up the temperature requisite for maturing the brood.

The common supposition, that the combs are discoloured by the brood and pollen (or brood bread), is only partially correct; for, in weak hives, the cells containing them are not much discoloured; while in strong stocks, not only they, but the outside combs, soon become dark; a proof that the discoloration is more the effect of great heat, the cells being flexible, and the constant traffic of the bees having the pollen about them, than of the brood.

As a farther proof that virginity of the queens has nothing to do with the purity of the honey, old blackened combs will yield honey as pure as fresh ones, provided the honey itself be of the same age, and gathered from the same kind of flowers. This fact is very easily ascertained by piercing the cells, to let the honey drip out. Much good honey is spoiled by its being squeezed from the combs. The combs should be cut or carefully broken, and allowed to drip through a muslin bag.

Cossey Hall Gardens, April 2. 1840.

REVIEWS.

ART. I. *Transactions of the Horticultural Society of London.* 2d Series, Vol. I. Part V., and Vol. II. Parts I. II. III. 4to. London, 1833 to 1840.

(Continued from p. 348.)

59. *REPORT on some of the more remarkable hardy ornamental Plants raised in the Horticultural Society's Garden from Seeds received from Mr. David Douglas, in the Years 1831, 1832, 1833.* By George Bentham, Esq., F.L.S., Secretary. Read June 17. 1834.

These are *Ribes glutinosum*, *R. malvaceum*, *Leptosiphon androsæceus*, *L. densiflorus*, *Gilia tricolor*, *Phacelia tanacetifolia*, *Nemophila insignis*, *Collinsia bicolor*, *Chelone centranthifolia*; all now common in the nurseries.

60. *Meteorological Journal, &c.*, as before.

61. *Remarks on the Growth of a peculiar Fir resembling the Pinaster.* By Sir C. Lemon, Bart., M.P., F.H.S.

The plant in question is a pine, not a fir. It is a variety of the *Pinaster*, characterised by the form and position of the cone, and the effects of the growth of the tree resulting from that position. In the common *Pinaster*, the cone is oblong, tapering towards the base, and having large projecting echinate scales, with deep fissures between them. In the kind in question it is smaller, more ovate, tapering but little towards the base, and having moderate-sized unarmed scales with shallow furrows between them. The position of the cone is a still more striking distinction. In the common *Pinaster*, the cones, of which there are generally three or four, are situated behind the shoots of the whorl, and in the mature state point backwards. In this obscure species, on the contrary, the cone is single, and it as universally occupies the place of the leading shoot, the side shoots being behind it. The necessary consequence of

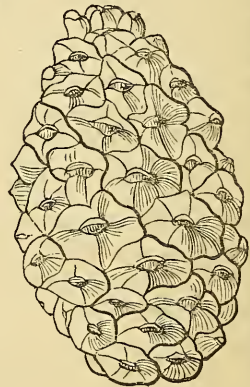
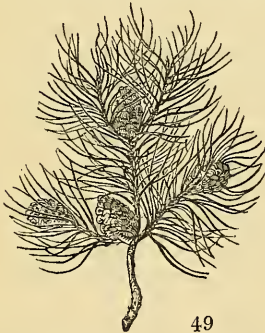

this position is, that the tree can have no regular leader, but each year one of the side shoots strengthens and continues the growth for the ensuing season. The year following, the same process is repeated in another direction; a new axis of growth is formed, and the stem of the tree acquires a zigzag appearance, which is never entirely lost, though of course much obliterated by age."

These distinctive characters, Sir C. Lemon observes, may indicate: 1st, a distinct species; 2d, a hybrid, between adjacent species; or 3d, an accidental, perhaps permanent, variety."

In a note by the secretary, it is characterised as a "species of *Pinus* not hitherto described," and named *P. Lemoniàna*. We consider it, judging from the plant in the Horticultural Society's Garden, as a variety of the *Pináster*; and in our *Arboretum Britannicum* we have named it *Pinus Pináster Lemoniànus*. An excellent figure is given in the *Hort. Trans.*, from which our *figs.* 49. and 50., are copied, and given in the *Arboretum*.

62. *Upon a new Method of applying Hot Water to heating Stoves.* By Alexander Cruickshanks, Esq., C.M.H.S. Read May 20, 1834.

It may be sufficient, with regard to this ingenious invention, to state that the boiler is cylindrical, and placed horizontally, and that it includes a smaller cylinder containing the fire.

63. *Note upon a handsome and [half-]hardy Plant, called Clíánthus puníceus.* By John Lindley, Ph. Dr., F.R.S., &c. Read December 2, 1834.

This beautiful New Zealand shrub is now too well known to deserve description or recommendation. We have just seen some fine specimens of it in the open air, in the garden of Park Cottage, Blackheath, the residence of John Sheepshanks, Esq.; and a fortnight ago, we saw a splendid specimen covering a space, we should think, upwards of 12 ft. square, on the conservative wall at Chatsworth.

64. *A further Account of Experiments on the Cultivation of the Potato, made in the Garden of the Horticultural Society, in the Year 1834.* By John Lindley, Ph. Dr., F.R.S., &c. Read January 30, 1834.

The object of these experiments was, to repeat the comparison of whole tubers and sets, and to illustrate the advantages and disadvantages of close or distant cropping. The advantage of planting potatoes apart, and wider and deeper than usual, is considered as being sufficiently proved by the former experiments. (See p. 346.)

The ground was divided into four equal parts. In one of these the rows of potatoes were as much as $2\frac{1}{2}$ ft. apart; in another, 2 ft.; in a third, $1\frac{1}{2}$ ft.; and in the fourth, only 6 in. Half of each division was planted with whole tubers, and half with sets cut to a single eye. The whole were committed to the ground on the 27th of February, the tubers or sets being, in every case, 6 in. apart in the rows, and 9 in. deep.

On the 24th of April the points of the potatoes had reached the surface of the soil, and the next day about 3 in. of soil were drawn over them, for the purpose of protecting them from ground frosts, which, in low and flat places like the Society's Garden, are still prevalent at that time of the year. By the 2d of May, the whole surface of the ground, in the division where the rows were only 6 in. apart, was a mass of entangled stems. By the 20th of the month, the stems in the division where the rows were $1\frac{1}{2}$ ft. apart, had nearly covered the ground; and, in a week after, those in the 2 ft. division were in the same state; but the ground was not covered during the whole season, where the rows were $2\frac{1}{2}$ ft. apart.

The shoots from the whole tubers were, in all cases, much stronger than those from the single eyes, but they began to be prostrated in the 6 in. division on the 29th of May, and the whole of them, in all the divisions, were in the same state by the 27th of June; while the stems from the single eyes continued erect till they began to turn yellow and wither, in the end of August. This will, probably, account for the superiority of sets over whole tubers; could the crop be protected from winds, and the stems of the tubers be prevented from breaking, I have no doubt that tubers would yield the largest crop; but their very vigour makes them brittle, and once broken, they are no longer able to perform their functions perfectly.

The greatest length to which the stems attained was 2 ft.; the principal part of them attained that length, but many did not exceed $1\frac{1}{2}$ ft.; and those in

the division where the rows were at that distance were the most uniform in their appearance. The important inferences to be drawn from this were afterwards shown by the result.

On the 26th of September the whole crop was taken up, freed from mould, and weighed. Where the rows were only 6 in. apart, a number of the new potatoes were partially decayed, and a very large proportion was too small to be fit for use. The most uniform size was obtained from the division where the rows were 2 ft. apart.

The result of this experiment Dr. Lindley considers "the most interesting yet obtained, for it not only reduces to something like a demonstration the superiority of sets over whole tubers, but it shows that the crop will be greater where the distance between the rows is most in accordance with the average height of the potato stems; and that, if we take the minimum height, which in this variety is $1\frac{1}{2}$ ft., although the crop may be the most promising while growing, it will, in reality, be smaller than when the branches are less dense.

"Thus the most uniform crop of stems, in this experiment, was in the division where the rows were $1\frac{1}{2}$ ft. apart; but the crop in that division was less by 1 ton 3 cwt. 97 lb. than where the rows were 2 ft. apart, that is, equal to the average height of the stems."

The neat return of the single eyes, where planted at 2 ft. apart between the rows, was at the rate of 24 tons per acre; at 18 in. between the rows, 22 tons per acre; at 2 ft. 6 in., 16 tons; and at 6 in. between the rows, 16 tons. The produce in the neighbourhood of London, as estimated in different places, is from 12 to 15 tons, the rows being from 22 in. to 24 in. apart, and the distance of the sets in the frame 6 in. to 9 in. The depth at which the sets were planted varied from 4 in. to 8 in.; but 9 in. is the depth that Mr. Knight and Dr. Lindley recommend.

65. *Report on the Special Exhibitions of the Horticultural Society of London.*
By G. Bentham, Esq., F.L.S., Secretary.

This contains a list of the persons who received medals from the year 1832, when the exhibitions commenced, to the end of the year 1834.

VOL. II.

1. *Meteorological Journal, &c.* By Mr. Robert Thompson.

2. *Upon the Causes of the Diseases and Deformities of the Leaves of the Peach Tree.* By T. A. Knight, Esq., F.R.S., Pres. Read July 15. 1834.

"Every gardener knows that the leaves of peach trees frequently become diseased and deformed, owing to the operation of two perfectly distinct causes; one being obviously the depredations of insects, and the other being generally, I believe universally, supposed to be frost. In the last-mentioned case, the leaves, if suffered to remain upon the trees, continue to grow, and in part to perform their office of generating the living sap of the tree; but the whole, or nearly the whole, of the fluid thus created is expended in their own deformed and morbid growth. In unfavourable situations, such as mine unfortunately is, a large portion of the first-formed leaves is frequently rendered useless, or worse than useless; and I do not recollect a single season in which a very large part, and sometimes all the early foliage of my peach and nectarine trees, which almost wholly occupy the entire south wall of my garden here (Downton Castle), has not been destroyed or rendered useless, previously to the present season.

"In the autumn of the year 1831 a small nectarine tree, which grew in a pot in my peach-house, was removed from it, and planted in the open air, amongst other trees of the same species. A few of the species of scale insect which is the usual pest of the peach-house were then transferred to the peach trees

upon my open wall, on which they increased considerably during the succeeding summer and autumn, and extended themselves over nearly a whole tree on one side, and over nearly half a tree on the other side. In the following winter my gardener applied to the trees to which these insects had extended themselves a mixture of lime and flowers of sulphur, dressing the whole of one tree, and about one half of the other. In the following spring, whether owing to the application above-mentioned, or, as is, I think, more probable, the effects of winter, the insects wholly disappeared: and the following very singular circumstances occurred. The leaves of all the peach trees growing in the situation above-mentioned were almost wholly destroyed in the spring of 1833, exclusive of those of the trees to which the mixture of lime and flowers of sulphur had been applied; whilst all the foliage of one tree, and that of one half of the other presented a perfectly healthy character, as far, precisely, as the dressing above described had extended. In the spring of the present year, when the blossom buds of my peach trees had acquired about the size of hemp seeds, water holding in solution or suspension a mixture of lime and flowers of sulphur and soot was thrown upon all the peach trees above-mentioned, with an engine, in sufficient quantities to wet the whole of the trees and wall, but not materially to affect the colour of the wall. No injurious effects followed, and not a single blistered leaf has appeared upon my trees, which are bearing an abundant crop of fruit, and, present an appearance of health which I have certainly never once before witnessed within the last thirty years.

“The red spider had generally abounded upon my peach trees in the preceding year, and had given my gardener a good deal of trouble; but in the present season very few appeared, and none apparently remain. The dislike of this very troublesome insect to sulphur is well known, and I do not entertain any doubt that, relatively to those, the application of it operated very beneficially; but I am wholly unable to conjecture by what mode of operation it could have acted beneficially in preserving the foliage of my trees; and, whether it did or did not cause their preservation, can only be determined by future experiment.”

3. *Particulars respecting the Mode of Cultivation, &c., of the Averrhoa Carabòla.* By James Bateman, Esq., F.H.S. Read December 3. 1833.

Mr. Bateman having ripened fruit of this East Indian tree for the first time in Europe, has given the following account of his mode of culture; premising that the tree has “an elegant spreading head and light airy foliage, something similar to that of the acacia; it is very prolific and produces fruit three times a year, from the age of three to fifty.

“In cultivation it requires to be plunged, but not in any heating substance. My plant, which I received only last year from Messrs. Lee of the Hammer-smith Nursery, has attained the height of about 5 ft., with a naked stem for four fifths of the distance; this as well as all the older branches became covered in July with countless clusters of elegant though minute rosy flowers, a succession of which continued for upwards of three months, and I doubt not, that, had the plant been allowed more pot room, instead of setting only six fruit it would have borne as many dozens. The fruit, from the time of their setting, steadily advanced in size, never having had (like peaches and most other fruits) any period during which they were stationary.

“Nothing could be more beautiful or singular than their appearance as they approached maturity; their colour was intensely golden, and they diffused too a rich aromatic perfume; but the most remarkable feature in the fruit is, the five excessively prominent angles, which present, as far as I am aware, a unique form among edible fruits. Upon trial, it was found that this fruit possessed qualities of the first order when made into a preserve.”

It may not be useless to add that this tree is one of the worst known in our stoves for the mealy bug, being worse even than the coffee tree.

4. *On the Cultivation of Chlidanthus fragrans, a hardy bulbous Plant.* By R. W. Byres, Esq. Read July 16. 1833.

This elegant and fragrant flower, Mr. Byres finds to be of as easy culture as the narcissus. He first tried it in the stove, and afterwards the frame, but found that high temperature had the effect of fretting the bulb into offsets, and not of enlarging it. Afterwards he planted it under a south wall, in a bed 18 in. deep, in the soil in which he grows his collection of amaryllis (turfy loam, sand, and decayed vegetable matter), planting the bulbs 6 in. deep, and protecting them during winter by mulching. In the April of the next year, Mr. Byres observes, "They began to show themselves; I was satisfied they were getting stronger, as very few offsets appeared and the leaves were more sturdy; hoping for a flower in 1832, I again lifted them undisturbed, but not a bulb threw up a scape, and after they had made most vigorous foliage, and gradually died off, I took up the plants in November, when some very fine bulbs were obtained, nearly as large as *Sprekelia formosissima*, or four times larger than the original bulb obtained from the nursery.

"I potted seven bulbs, four of which flowered in the green-house in April. The remainder of the bulbs I planted out as before, and one of them in the end of May threw up its scape, and flowered."

5. *Upon the Causes of the premature Death of Part of the Branches of the Moorpark Apricot, and some other Wall Fruit Trees.* By Thomas Andrew Knight, Esq., Pres., F.R.S. Read June 2. 1835.

The following very excellent paper deserves the attentive perusal of the young gardener:—

"The branches of all trees, during much the larger portion of the periods in which they continue to live, are in their natural situations kept in continual motion, by the action of wind upon them; and of this motion their stems and superficial roots partake, whenever the gales of wind are even moderately strong: and I have shown, in the *Philosophical Transactions*, that the forms of all large and old trees must have been much modified by this agent. The motions of the circulating fluids, and sap of the tree, are also greatly influenced and governed by it; and whenever any part of the root, the stem, or the branches, of a tree are bent by winds or other agents, an additional quantity of alburnum is there deposited; and the form of the tree becomes necessarily well adapted to its situation, whether that be exposed or sheltered. If exposed to frequent and strong agitation, its stem and branches will be short and rigid, and its superficial roots will be large and strong; and, if sheltered, its growth will be in every part more feeble and slender. I have much reason to believe, upon the evidence of subsequent experiments, that the widely extended branches of large timber trees would be wholly incapable of supporting their foliage when wetted with rain, if the proportions of their parts were not to be extensively changed and their strength greatly augmented, by the operation of winds upon them during their previous growth. Exercise, therefore, appears to be productive of somewhat analogous effects upon vegetable and upon animal life; and to be nearly as essential to the growth of large trees, as to that of animals.

"Whenever the branches of a tree are bound to a wall, they wholly lose the kind of exercise above described, which nature obviously intended them to receive; and many ill consequences generally follow; not however to the same extent, nor precisely of the same kind, to trees of different species and habits. When a standard plum or peach tree is permitted to take its natural form of growth, its sap flows freely, and most abundantly, to the extremities of its branches, and it continues to flow freely through the same branches during the whole life of the tree: but when the branches are bound to a wall, and are no longer agitated by winds, each branch becomes in a few years what Duhamel calls 'usée,' that is, debilitated and sapless, owing apparently to its being no longer properly pervious to the ascending sap. The obstruction

to the ascent of this causes luxuriant shoots to spring from the lower parts of the tree; and these are in succession made to occupy the places of the debilitated older branches by the process which the gardener calls 'cutting in.'

"The branches of the apricot, and particularly of the Moorpark varieties, often die suddenly, owing to the same cause, with much more inconvenience and loss very frequently to the gardener; for trees of this species do not usually afford him the means of filling up vacancies upon his wall, as those of the peach and plum do.

"The pear tree better retains its health and vigour, when trained to a wall, than those of either of the preceding species, or than the cherry tree; but the proper course of its sap is nevertheless greatly deranged; and it is difficult, and in some varieties almost impossible, to cause it to flow properly to the extremities, or nearly to the extremities, of its branches. Much the larger part of it is generally expended in the production of what are called 'foreright' useless shoots; and the quantity of fruit which is afforded by the central parts of an old pear tree, when trained to a wall, is usually very small.

"The vine alone, amongst fruit trees, appears capable of being bound and trained to a great distance upon a wall without sustaining any injury, its sap continuing to flow freely and abundantly to its very distant branches. Owing to a peculiarity of structure and habit, which is confined to those species of trees, from which nature has withheld the power of supporting their own branches, the alburnum of all plants of this habit is (as far as I have had opportunities of observing) excessively light or porous; and not being intended by nature to support its own weight, or that of any part of the foliage of the tree, does not acquire with age any increased solidity, like that of trees of a different habit, and on this account probably it never, how long soever deprived of exercise, loses in any degree its power of transmitting the ascending sap. The alburnum of those trees which nature has caused to support themselves without external aid becomes annually more firm and solid, and consequently less well adapted to afford a passage to the ascending sap, and as heart-wood it is totally impervious to that fluid. Whenever the branches of such trees are wholly deprived of exercise, too rapid an increase of the solidity of the alburnum probably takes place; and it in consequence ceases to be capable of properly executing its office. I have, of course, never had an opportunity of examining the character of the alburnum of the *Glycine sinensis*, of which the garden of this Society contains so splendid a tree; but I do not entertain a shadow of doubt of its being extremely light and porous, like that of other trailing and creeping plants, which depend for support upon other bodies."

6. *On Forcing Peaches and Nectarines.* By Mr. John Mearns, F.H.S., of Welbeck Gardens. Read March 3. 1835.

Mr. Mearns, having reason to believe that his method of cultivating peaches and nectarines, and especially of forcing them, differs from the general practice, has given an account of it, which we give in his own words.

"I do not approve of the Dutch method of resting the trees every alternate year; the practice is a bad one, as the tree once forced, when due attention has been paid to the roots, is in the best state for early excitement again; a tree taken direct from a wall not so, as it is excited two or three months before its natural season. If a judicious attention be paid to the roots, the same tree is far more successfully forced for a great many years. A late gardener to Lord Stafford, on seeing my practice, informed me some years ago of an amateur clergyman near Norwich, who had successfully forced the same trees for more than thirty years. His practice was to take them up every season as soon as they had done growing, and to plant them against a northern aspect till the end of November; and in the mean time to clear all the soil from his border, and fill it again with well prepared compost. His usual time to commence forcing was the beginning of January.

“ I had a small house erected for the experiment at Shobdon Court many years ago to try the practice, and followed it up for two years with success ; but the removal of the trees is unnecessary, as, with a due attention to the roots, the following method answers better, and is attended with much less trouble and expense than the above.

“ There are few gardens that have so much north walling to spare, and a better end is obtained without the sacrifice.

“ I confine the roots of my trees for forcing within a walled border of from 4 ft. to 6 ft. wide, according to the extent of surface which is desired for my trees to cover, and from 16 in. to 18 in. deep. The soil which I use to plant my trees in is nothing else than the perfectly fresh turfy top from a good mellow loamy pasture field, coarsely chopped up ; and, if the trees are of a proper age, the crop will be as fine the first season as at any future period.

“ I water plentifully, but judiciously, in the swelling season ; but more plentifully in the last stage of swelling, and then the fruit will swell off to a fine size, if the following attentions be paid.

“ As soon as the fruit begins to change colour I leave off watering the roots almost entirely, and none over the leaves and fruit till all is gathered ; at the same time exposing them as much as possible to the direct action of the sun's rays and atmospheric air, till all is gathered ; and, that I may lose no time in my forcing by so much exposure to the atmospheric air and direct rays of light, I allow the house to be very hot in the morning before I give air ; and then I give it by degrees, till the roof is completely thrown open ; and again, unless rain falls, I do not shut up till late in the day, and then in sufficient time to allow of having a high temperature, either with fire or sun, so as to accelerate the forcing, till I commence gathering ; at which period, if I have enough for my demand, I keep all as open and exposed as possible, only sheltering from rain to the last. When I remove the lights, I wash the trees several times, powerfully, and give a good soaking to the roots with soft, rain, river, or pond water.

“ I renovate the roots every three or four years, by taking off 6 or 8 inches from the top of my border, not even sparing the small roots ; and also 1 ft. or 18 in. from the extremity of the border, so as to clear away all the roots matted against the wall, and fill up the trench as at first with fresh turfy soil, and forking a portion in amongst the roots over all the border, so as to raise it a little above its former height ; by this practice the trees are sufficiently renovated for three or four years more, and do not receive such a check as by the Dutch practice. It is astonishing to see the extraordinary accumulation of spongelets which have ramified through every part of the fresh soil by the time the fruit has stoned.

“ No tree will thrive, whatever the soil may be, if insects and moss are suffered to harbour upon them ; and the best time to remove them is just when the winter pruning is over ; I then go over every tree about the houses and walls, in the most careful manner ; first scraping off all possible extraneous matter, after the trees are taken from the trellis or wall. My composition is as follows :—

“ The strongest drainage of the farm-yard, 1 gallon ; soft-soap, 1 lb. ; flowers of brimstone, 1 lb. ; mix : let all stand for several days, stirring the mixture three or four times a day ; get ready some finely sifted quicklime, and stir into it, till of the consistence of good stiff paint, when it is ready to be applied. Its effects are certain and excellent.

“ The tools I lay it on with are painters' sash-tools, of different sizes. I coat over carefully every part of the tree, so effectually that not a bud, chink, or crevice, escapes the mixture. I use the whitest lime for my hot-houses, as, when dry, I can see any axil of a bud or crevice that may have escaped the first dressing, and, to make sure, I go over them two or three times. After such a dressing I find all animalcules so completely destroyed, that neither green fly, thrips, scale, or red spider is to be seen during the season.

“ I am indebted to our excellent and indefatigable President for the above recipe, with some little alteration.

“As white lime does not look sightly upon wall-trees, I either mix soot with it, or else use the mixture without either the soot or lime; and frequently, instead of the drainage of the farm-yard, I have employed tobacco-liquor, mixed with soft-soap and sulphur.”

7. *On the Power possessed by Plants of absorbing coloured Infusions by their Roots.* By G. J. Towers, Esq., C.M.H.S. Read November 4. 1834.

Various physiologists have immersed cuttings of a variety of plants into coloured infusions, with a view to detect the conduits of the sap. For several seasons, this was done by Mr. Towers, who was always able to trace deposits of the colouring matter made use of, among and around those bundles of fibres which were considered the conducting vessels of the ascending sap. After trying a number of experiments by watering balsams growing in soil with coloured infusions, without being able to detect the slightest appearance of colour in the vessels of the plants, even though investigated with the microscope, the plants thriving all the while as well as those watered with ordinary water, Mr. Towers immersed rooted balsam plants in the same kind of liquid infusions with which he had watered the soil, when they all perished; the rooted balsam in the infusion of Brazil wood, and in a solution of iron, in a few minutes, and a balsam cutting within six hours! Thus it is proved, says Mr. Towers, “that the identical liquid which yields life, support, and health to roots when ramifying in a bed or matrix of earth, will destroy as with a stroke of lightning, those same plants when they are exposed to its immediate agency.

“I argue then from the results which I have detailed, first, that coloured or chemical infusions and liquids will not enter into the vascular or cellular system, provided the plant, either by its own vital energy, or by the decomposing power of the soil, remain in a state of health and power to develop its new parts; therefore, that no precise knowledge of the sap vessels can be obtained by such artificial means as have usually been employed. Secondly, That where a plant ceases to grow, turns yellow, and evidently becomes sickly, it may absorb unnatural aliment; not, however, through its regular organs of absorption, but by diseased action through, in all probability, abraded surfaces; hence then, while vital energy acts, and health remains unimpaired, true sap alone is generated. The office of soil is to reduce all substances to its own nature; and this it speedily effects through the stimulus of living vegetation. If, however, substances foreign to soil superabound, injury, as abrasion or corrosion, is, I apprehend, induced; diseased action and absorption supervene; the plant becomes poisoned, sickens, and perishes.”

8. *On the Means employed in raising a Tree of the Impératrice Nectarine.* By T. A. Knight, Esq., F.R.S., Pres. Read February 3. 1835.

The tree sent was composed of an almond stock, raised from seed in the spring of 1834, in which two buds were inserted on opposite sides, in the end of April of the same year. The plant was in a pot in a forcing-house, and as soon as the buds were properly united to the stock, the plant was placed under a north wall. After being there a few days it was headed down, and again brought into the forcing-house, when the two inserted buds vegetated, and each produced a lateral branch, which acquired the length of about 2 ft. 6 in., and formed a few blossom buds! Mr. Knight considers the almond as a stock for the peach and nectarine, only inferior to the plum in not so well bearing transplantation. For this reason the plant above-mentioned was kept in a pot, and sent in that state to the Horticultural Society. “I will request,” says Mr. Knight, “that the little tree sent may be planted in fresh unmanured soil, without having the branches shortened, and so superficially that a part of its roots may remain permanently visible above the soil. The fruit, which it will produce, will not be nearly as good as that of an older tree; and it is

therefore my wish that some buds should be taken from it in the next season, and inserted into the branches of more mature trees.”

9. *Abstract of a Memoir on the Cultivation of French Pears in Scotland, and on the Foundation and Management of Fruit Borders, with the View of bringing the Trees into a bearing State at an early Period of their Growth, and increasing their general Productiveness.* By Mr. George Drummond, Gardener to Sir Robert Preston, Bart., communicated by the Council of the Caledonian Horticultural Society. Read April 7, 1835.

We give this long article entire, because we consider it one of the most important which has appeared in the *Horticultural Transactions*. We should have had some hesitation in doing this without the permission of the Council, had the paper not already appeared in another journal.

“The attention of Mr. Drummond seems to have been particularly directed to the subject of this memoir by the following circumstances. The property of Valley Field, which belonged to the late Sir R. Preston, is situate on the north side of the Frith of Forth, and possesses a fine southern aspect. The site of the cottage-garden, in which Mr. Drummond’s experiments were first made, is placed close on the Frith, and was previously occupied by pans, and all the other buildings required for the manufacture of salt. In 1815 and 1816, these buildings were removed, the ground was enclosed by a wall, a cottage erected, and one part of the enclosed area was laid out as a flower-garden, and the remainder formed into a marine fishpond.

“When the ground was levelled for the garden, it consisted almost entirely of coal ashes, brick-bats, and lime rubbish, to which were added about 15 in. of fresh soil to prepare it for the flowers and shrubs. As it was proposed to plant French pear trees in the borders next to the walls, the fresh soil was there trenched down about 18 in., and mingled with the rubbish. Another foot of fresh soil was then laid over the whole surface of the border, and the trees planted.

“It was predicted that a border so formed would never answer, but would assuredly canker the roots of the trees; this, however, has not happened. On the contrary, the crassane, Saint Germain, chaumontel, colmar, brown beurré, bergamotte de paques, and jargonelle, all produced fruit the third year after they were planted, and have continued to yield excellent crops ever since, far greater than similar trees planted in the deep rich borders of the other gardens. Of these latter trees, many had been planted twelve years before they produced any fruit: they grew however vigorously, ran greatly to breast-wood, and continued to grow so late in the season that the flower-buds were frequently but ill-formed, and the young wood imperfectly ripened. The fruit also, which they produced, was borne chiefly at the ends of the branches, and was frequently hard and gritty at the core. On the other hand, the trees in the cottage garden seem to have acquired a different habit; they did not, indeed, grow so vigorously, and they produced little breast-wood; but they ripened their young wood earlier in the autumn, and fruited more regularly over the whole surface of the tree. On a given surface of wall, therefore, not only was the produce of the cottage-garden tree greater, but its quality much superior.

“The early productiveness and fertile habit exhibited by the trees just mentioned, led to the adoption of nearly the same methods in preparing two other borders. One of these was formed in 1820; as much of the rubbish of old buildings as would form a layer of about 14 in. in thickness, was spread over the whole border. On this was laid a stratum of rich manure, about 6 in. thick; and the whole was then trenched and turned over in such a way as to mingle the rubbish and manure with the soil of the border, but not going so deep as to encroach on the subsoil. The whole being thus mixed together, and made level, was then covered with about 1 ft. of fine light soil. In the border thus formed, two crassanes, two French bergamottes, two grey

auchans, and one muirfowl-egg pear were planted; they were what are generally called 'dwarf maiden plants.' All these trees showed fruit in the third year, and bore a beautiful crop in the fourth year after they were planted, and the crops produced every year since have been astonishing. The surface of this border every winter gets a dressing of cow-dung, which is dug in about 8 in. below the surface.

"In 1822, another border was similarly prepared by mixing up the rubbish of an old wall with the soil of an old border, to which no dung was added, lest it might make the soil too rich; but this Mr. Drummond has since regretted, as he finds that where stones and rubbish are mixed with the soil, there is no danger in making a free use of rich manure. In the spring of 1823, French pear trees were planted in this border, and they afterwards came as early into a bearing state, and continued to be as productive, as the trees at the cottage garden.

"By thus mixing stones and rubbish with the soil of the border, and forming the border above the subsoil, we are able to bring French pear trees into a bearing state at a much earlier period of their growth, and to render some varieties of these trees, hitherto considered as shy bearers, not less productive than those of the more common kinds.

"Mr. Drummond next points to the analogy between his method of forming borders for pear trees, and that employed when plants are cultivated in pots or boxes. In the latter, pieces of potsherds, shivers, or other substances, are laid at the bottom of the pot to drain off superfluous moisture, or are sometimes mingled with the soil of the pot or box, when they are of large size, else the fibrous roots of the plant would probably perish during the winter, when vegetation is suspended. Now the roots of wall-trees, in an artificially prepared border, are in a very similar state, if the soil be deep and no stones or rubbish mingled with it; for a great body of fine earth, without such admixture of stony substances, is too retentive of water during the winter months, which proves very injurious to the fibrous roots of trees in our cold damp climate.

"Many opportunities of lifting the roots of trees, in borders differently formed, have afforded illustrations of the foregoing facts; for those roots raised from borders where the soil was mingled with stones and rubbish have presented a dense mass of fibrous rootlets; whilst others, which had grown in deep and rich borders without such admixture of stony substances, have exhibited only long naked roots, more or less destitute of fibrous appendages. In the rubbish borders, the fibrous rootlets might be seen to seize, as it were, on some substances of the soil in preference to others; pieces of lime-plaster, or mortar, were generally preferred, being often found enveloped in a mass of such rootlets; next to these, pieces of whinstone and brick were selected by the rootlets; coarse gritty sandstone they seemed to reject, but to like the fine white sandstone which the roots of heaths are so fond of.

"In connection with this search after stony bodies, Mr. Drummond mentions some curious facts respecting the directions which roots take in borders formed, in part, of paving stones. If such stones be laid at the bottom of the border with the view of preventing the roots striking into the subsoil, the trees will soon send down their roots until they come in contact with the pavement, over the surface of which they will then spread themselves in every direction. Should their extremities not be able to penetrate the mortar or clay in which the stones are embedded, they will, after a time, push out beyond them, and then, dipping down, take an inverted position and extend beneath the pavement. On the other hand, if the stones be laid on the surface of the border instead of its bottom, the roots then seem to strike upwards, and spread along the under surface of the stones. In both cases the stones seem to attract and retain moisture, and, during the vegetating season, the roots strike towards them in order to obtain it; but with this difference in the ultimate result:—when the stones are laid at the bottom of the border, the principal roots are detained there, and their fibrous rootlets are more or less

destroyed, during the winter, by the too great moisture to which they are exposed; in such circumstances, the trees grow vigorously, but produce comparatively little fruit, and that of inferior quality: but when the stones are laid on the surface, the principal roots are also formed there, and their fibrous rootlets are thus preserved in a healthy state during winter; such trees grow less vigorously than in the former case, but they produce excellent crops of fruit, and that of superior quality.

“From the results of his experience, the author is led to conclude that two errors are, in general, committed in forming borders for wall-fruit trees. The one is that of trenching too deeply, with a view of increasing the depth of the border, by which the subsoil is disturbed; the other consists in collecting too great a body of fine earth in the border, without a due admixture of stony substances.

“With respect to the first error, or removal of the subsoil, its effect is to convert the border into a sort of receptacle both for collecting and retaining water, and to bring it nearly to the condition of a flower-pot whose bottom is immersed in a pan of water. No operation of draining will keep such a border in a condition suited to the welfare of the trees; and nothing can be more injurious to the roots than keeping them in stagnant water through the greater part of the year. If it be wished to augment the depth of the natural soil in the borders, this should be done, not by excavating the subsoil, but by adding to the height of the upper soil. All hard-wooded trees and shrubs thrive best in a border raised above the level of the surrounding ground. In our damp climate, the roots of the finer sorts of trees thus preserve a healthier state during winter; and on the return of spring, the soil of a raised border receives more solar heat, which contributes to accelerate and augment the fertile habit of the tree.

“As to the second error, that of accumulating too much fine mould, without a due proportion of stony substance, Mr. Drummond remarks that, in the natural soils in which trees best grow, we can seldom penetrate, even in carse lands, above 1 ft. below the surface, without meeting with stones and other substances favourable both to the development and preservation of fibrous roots; and, in local situations famed for the production of fine fruit or hard-wooded trees, an examination of the soil and subsoil will show them to possess the characters above-mentioned, and to be thus favourable to the formation and preservation of fibrous roots. In no instance ought we to collect above 2 ft. of fine earth in a border, without, at the same time, mixing with it a due proportion of small stones, or other solid substances. Such an intermixture of stony bodies contributes not only to augment the number of fibrous roots, but to prevent the accumulation of too much moisture in the winter months.

“As the result of his enquiries and experience, Mr. Drummond recommends the following mode of forming a border, as suitable for every variety of fruit-tree which we are in the custom of raising against walls. He would make the border at least 20 ft. wide: it should be composed of $2\frac{1}{2}$ ft. in depth of good soil, rather light, with 1 ft. of broken whinstones and lime rubbish, and 1 ft. of cow and stable dung. These several ingredients should be thoroughly mixed together, and, when the whole has been levelled, another foot of fine mould should be spread over the whole surface. The walks he would lay down on the surface of the border at the distance of 10 or 12 feet from the wall; and this should be done in such a manner as that the surface of the border may have a gentle slope from the wall to the walk, and the slope then be continued from the walk to the natural surface of the ground. On no account must the subsoil be disturbed.

“Those who are advocates for the shallow planting of fruit trees may suppose the border recommended above to be too rich, and that it will promote too great luxuriance of growth; but, provided the materials employed favour the production of fibrous rootlets, we can hardly ever make the border too rich. Encouraging such rootlets seems to produce that fertile habit in the

tree at an early stage of its growth, which checks any tendency to over-luxuriance afterwards; and to turn the powers of the tree to the formation of flower-buds, and consequent production of fruit. Wall-trees are exposed to a higher temperature and greater evaporation than standards, and require, therefore, a larger body of soil and a more copious supply of moisture for their roots than standards do.

“ Having thus stated his views concerning the proper formation of borders, Mr. Drummond proceeds to notice some other circumstances to be attended to in their subsequent management: and this portion of his memoir is also illustrated by experiment.

“ When the borders have been properly prepared, success in the cultivation of wall-fruit trees depends more, says our author, on a judicious supply of moisture to their roots, than on any other part of the practice. The necessity of moisture to the due preparation of the food of plants, and to its entrance into the vegetable system, is well known; but if the soil get beyond a certain state of dryness, these necessary operations cannot proceed, and little or no nutriment can be afforded, at the very time, perhaps, when it is required most to assist in the production of fine fruit. The roots also, unable to find nutriment in a good soil, may penetrate into a bad one, and from thence derive matter not only not nutritive, but perhaps pernicious to the vegetating process.

“ In supplying water, Mr. Drummond recommends that it be taken from a pond in which it has been freely exposed to the sun. If the pond be not more than 3 or 4 feet deep, the temperature of its water will not differ much, during the summer months, from that of the soil of a border of similar depth. In such circumstances, watering will rather augment than diminish the temperature of the soil; and will in no degree check the chemical changes by which the food is prepared in the soil, or impede the functions of the living organs destined to absorb it. Water from springs and wells, by reason of its coldness, considerably reduces the temperature of the soil, and ought not to be employed till its temperature has been raised nearly to that of the soil.

“ To ascertain the effects respectively produced by spring and pond water of different temperatures, Mr. Drummond, in the year 1826, made the following experiments:—he selected four peach trees of the same species (*grosse mignonne*), which grew against a wall. Two of these trees were supplied during the summer with water taken from the spring, and the other two with water from the pond. In the border where the trees grew, and which was 12 ft. wide, two thermometers were plunged into the soil to the depth of 18 in., and its temperature carefully noted at the two stations before the water was applied; and also on the next day, or twenty-four hours after the application of the water. The temperature, too, of each kind of water was duly observed. These observations being previously made, the border was watered three times during the summer; and each time as much water was given as would have formed about a cubic foot of water over the whole surface. The author has exhibited, in a tabular form, the times when the experiments were made, the temperature of the soil, the kind of water, and its temperature when used; the temperature of the border twenty-four hours after, and the amount of heat gained or lost by the kind of water employed.

“ The first experiment was made on the 10th of May. At the depth of 18 in. the temperature of the border was 64°, and that of the spring water used 46°. In twenty-four hours after, the temperature of the border was reduced to 52°, or had lost 12°. At the same time the temperature of the soil being 64° as above, and heat of the pond water 67°, the soil at the close of twenty-four hours was 66°, or, instead of losing 12°, had gained 2°.

June 20th, the second watering was given. The temperature of the border at the depth of 18 in. was now 74°, and that of the spring water 52°. In twenty-four hours the border was reduced to 58°, or had lost 16°. At the station where the pond water was used the temperature of the border at the

above-mentioned depth was 77° , and that of the water 82° . In twenty-four hours the temperature of the border was 80° , or had gained 3° .

“The third and last watering was performed on the 28th of July. The temperature of the border at 18 in. below the surface was 72° , and that of the spring water 57° . In twenty-four hours the border was reduced to 61° , or had lost 11° of temperature. At the pond water station, the border at the depth of 18 in. was 78° , and the water itself 74° . In twenty-four hours the temperature of the border was still 78° , or had suffered no change of temperature from the watering it had undergone.

“It is very clear from these facts, that, whilst spring water greatly cooled the soil, that from the pond exerted no such operation, but on the contrary often raised its temperature.

“In proceeding to describe the effects on vegetation produced by these different kinds of water, Mr. Drummond observes that on the 10th of May, when the border was first watered, there was no perceptible difference in the appearance of the four trees: they had all excellent crops of fruit. About the first of August, however the contrast was very striking. No one would then have supposed that the four trees were of the same variety. The fruit of the two trees which had been supplied with the pond water was much larger, of a higher colour, and finer quality, than the fruit of the other two trees which had been supplied with spring water. The leaves, also, of the former trees were almost double the size of those of the latter. Even in the following spring the difference was perceptible, as evinced in the larger blossom and more vigorous setting of the fruit.

“In the management of borders, it is of great importance, continues Mr. Drummond, to preserve the surface roots of trees. At the cottage garden the borders have never been dug since the trees were planted; and, when manure is applied, it is laid down and covered over with about 6 in. of the surface mould. The soil, when thus treated, becomes filled to the surface with fibrous roots, which would be injured or destroyed were the border to be dug. When the manure is retained in a body near the surface the border is kept in a moister state, and the roots do not penetrate downwards to the subsoil in search of water. Even where vegetables are raised as early crops on the border, the soil is never disturbed to more than 6 in. in depth; and the crops are ready earlier than in the ordinary mode of digging to the depth of 18 in. When the fibrous roots of trees have been injured by digging the border too deep, they will soon be restored if a layer of manure, 6 or 8 inches thick, be first laid on the surface, and then beaten down with the spade, and covered afterwards with about 6 in. of mould. The roots will at once begin to strike out and run along the under surface of the dung, forming at length a complete mass of fibrous roots.

“When vegetables are raised on fruit-borders, they may affect the atmosphere, in regard both to heat and moisture, in a degree that may sometimes prove beneficial, and at others injurious, to the trees. When the wall, for example, becomes heated, the air in contact with it is rarefied and carried upwards, and fresh air from the surface of the border moves forward to supply its place; in this way a current of air is soon formed, which continually passes over the heated wall as long as it retains an excess of heat. Of this circumstance advantage may be sometimes taken where the heat of the wall is excessive; for, by keeping the surface of the border in a moist state, we diminish at once the temperature, and augment the moisture of the atmosphere which envelopes the tree. On the other hand, by raking the border, as will afterwards be shown, we contribute to keep its surface in a dry state; and thereby to increase the temperature, and lessen the moisture of the surrounding atmosphere. At different seasons these opposite practices may be beneficially adopted. Thus in spring, when the trees are in blossom, should a clear frosty night set in, with the prospect of bright sunshine during the next day, it is of no little importance to water the surface of the border before the sun appears, as the evaporation that succeeds will moderate the excess of

heat which might otherwise prove fatal to the blossom. On the other hand, when the fruit is swelling it is of equal importance to keep the surface of the border dry, as the temperature both of the soil and atmosphere is then increased, which contributes much to improve the size and quality of the fruit.

“When, however, the borders are so thickly covered with vegetables as almost to prevent the access of the solar rays to their surface, such covering will contribute much to lower the temperature of the soil, and of the atmosphere in contact with the wall. To ascertain the extent to which this might take place, the author made the following experiments on a border covered with a strong crop of cauliflower, which completely shaded the surface. He took a thermometer and inserted its naked bulb about half an inch into the soil of the border, where it was covered with the vegetables. A second thermometer was laid on the surface of the border; and a third was placed in close contact with the wall. A similar arrangement was, at the same time, made with three other thermometers in another part of the border, which was uncropped, and fully exposed to the sun’s rays. The border itself was 12 ft. wide, and the wall of about the same height in feet. On the 10th of May, 1829, the author made four observations of these six thermometers, between 5 o’clock of that day, and 4 o’clock of the next, viz. at 5 A. M., 1 P. M., and at 10 P. M. of the 10th.; and at 4 A. M. of the 11th. The results of these observations he has given in a tabular form, of which a copy is exhibited.

May, 1829.	Cropped Border.				Uncropped Border.		
Time of Observation.	Temp. of atmosphere in shade.	Temp. of soil half an inch below surface.	Temperature of soil at surface.	Temperature on surface of wall.	Temp. of soil half an inch below naked surface.	Temperature of naked surface.	Temp. of wall at naked surface.
5 A. M.....	55	68	58	59	70	57	62
1 P. M.....	71	69	76	86	96	113	104
10 P. M.....	54	69	60	58	81	68	66
4 A. M.....	52	60	59	55	70	58	60
Increase of temperature from 5 A. M. to 10 P. M.....	16	1	18	27	26	56	42
Increase of temperature from 10 P. M. to 4 A. M.	19	—	17	31	26	55	44

“From this table it will be seen that at 1 o’clock P. M. the close crop of cauliflowers occasioned a reduction of 18° of temperature on the wall, as compared with that of the wall of the naked border: at 10 o’clock in the evening the difference of temperature between the two portions of wall was 8°; and even at 4 o’clock on the next morning the difference was 5°. On the 29th of May the cropped border was 4° lower than the naked one, at the depth of 12 in. beneath the surface.

“This effect of cropping, in lowering the temperature of the atmosphere, will, however, be much less when the sunshine is little and partial through the day; and when the day is wet it will not be observed. The colour, too, of the soil will influence the result, a dark soil becoming much hotter than a light-coloured one, when exposed in the same manner to the solar rays.

“Vegetables in borders are least injurious to wall trees when they are planted in rows at right angles to the wall, and at double the distance usually

allotted; they do not then so completely shade the soil, and the air is permitted to flow freely through the rows. It will, however, be proper to have them cleared away (when planted opposite to peach and apricot trees) about the middle of July, that the borders may have the full benefit of the sun's rays, to enable them to ripen the fruit and mature the young wood. After a wet night the borders should also be raked, to aid the drying of their surface. This simple operation will increase the temperature of the surface of the border, and of the wall, many degrees. On one occasion, after two days of continued rain in July, 1829, the temperature of the surfaces of the border and wall was the same as that of the atmosphere, viz. 52° , at 4 o'clock in the morning. At 6 o'clock, the weather cleared up, and a considerable extent of the border, opposite to a hot wall, was raked, so as to dry the surface. At 1 o'clock, a thermometer, laid on this raked surface, indicated 118° ; and another, applied to the wall opposite, 106° ; whilst, on the unraked surface of the soil, the temperature was only 86° , and on the corresponding portion of the wall 89° . The operation, therefore, of raking the surface of the border, raised its temperature 32° above the unraked surface, and the temperature of the corresponding part of the wall 17° .

"The London medal, for 1833, placed at the disposal of the Caledonian Horticultural Society, was voted to Mr. Gregor Drummond for the communication, of which a copious and correct abstract is here given."

10. *Description of several new Varieties of Fruit raised by Thomas Andrew Knight, Esq., from Seed; together with Notes thereon by Mr. Knight.*

The pears described are March bergamot, Pengethley, Ross, Oakley Park bergamot, Brougham (a sample having been sent by Mr. Knight to Lord Brougham, and approved of by His Lordship), Bringewood, Moccas, Broom Park, Croft Castle, Eyewood, Dunmore, and Monarch. All these pears were raised by Mr. Knight; but their merits are not yet sufficiently proved to warrant our recommending them without the special sanction of Mr. Thompson, who, if we have failed to do justice to any of these varieties, will, we trust, be good enough to correct us. Mr. Knight also describes the Dunmore plum, raised by him, and also a party-coloured grape, not unlike the white muscadine in flavour, which "has in every season ripened tolerably well in the cold climate" of Downton; and of which Mr. Knight says, "I believe it to be better adapted to make wine in a cold climate than any cultivated. I feel confident that it is superior to most of the grapes cultivated in France, and that the merits of the French wines depend greatly more on the skill of the makers, than upon the merits of their grapes."

11. *Note upon Mimulus cardinalis; a new hardy herbaceous Plant.* By John Lindley, Ph.D., F.R.S., &c. Read November 4. 1835.

This very showy and very hardy perennial, rare at the time this article was written, is already, thanks to the diffusive spirit which enters into every thing, now as common in gardens as columbine or sweetwilliam.

12. *Meteorological Journal, &c., for the Year 1835.* By Mr. Thompson.

13. *A Note upon Oncidium Lanceanum; a new Species of Orchideous Epiphyte.* By John Lindley, Ph. D., F.R.S. &c.

A well-known epiphyte, introduced in 1834 by J. H. Lance, Esq., and named in compliment to him.

14. *On Two Species of Insects which are found injurious to the Pear Tree.* By Thomas Andrew Knight, Esq., F.R.S., Pres. Read April 19. 1836.

"The leaves of pear trees which are trained to walls have sustained, during some years, much injury in many gardens, from the depredation of the larvæ of a very minute species of moth, the *Tinea Clerckella* of Linnæus: and I

have been informed that it abounded in the Royal Gardens at Kew in the last summer. The moth appears in the end of May and the beginning of June ; and it is readily distinguished by the silvery whiteness of its wings, which are tipped lightly with brown, and by its small size, its length scarcely exceeding a single line. It is an extremely pretty little insect, and possesses so much activity, that it is difficult to obtain a living specimen of it. It probably deposits its eggs, or, perhaps, more properly, its spawn, upon the under surfaces of the leaves ; and the larvæ, having there penetrated through the epidermis, feed upon the internal parenchymatous matter of the leaf. Brown and lifeless circular spots in consequence appear upon the leaves, such as an excess of heat would occasion ; and I have known several gardeners who have supposed it to be caused by solar action. These lifeless spots enclose the larvæ of the moth above mentioned, which do not exceed a line in length. Whenever the leaves of a pear tree contain many of these, the fruit does not acquire nearly its natural size, and it ripens without acquiring either sweetness or flavour.

“ This insect is an old inhabitant of our gardens : I first observed it half a century ago, but it appears latterly to have become much more abundant. It greatly prefers some varieties of pears to others ; the chaumontel appears, amongst the varieties in my garden, its favourite, and the glout morceau that which it likes least. The moth is, I believe, but little known ; for Mr. Curtis, who was so kind as to give me the name of it, did not possess a specimen till he received one from me. My pear trees had sustained, during many successive years, so much injury from the depredation of this insect, and their fruit had in consequence become so defective in freshness and flavour, that I resolved to uproot the whole of them, if I failed to succeed in destroying or driving away the insects : but in the last summer I had the good fortune to obtain perfect success in driving them away, by the means which I proceed to describe.

“ Early in the spring of the year, when the blossom buds of my pear trees were about the size of large peas, water, which held in suspension a mixture of lime and flower of sulphur and soot, in about equal portions, was thrown by an engine over the pear trees and the surface of the wall to which they were trained. I applied this mixture because I had observed, as I have stated in a former communication, that it had apparently prevented the appearance of blistered leaves upon my peach and nectarine trees, though by what mode of operation I was then, as I still am, wholly at a loss to conjecture : but since the first application of it, I have not seen a single blistered leaf upon any tree to which it was applied. I, of course, distinguish blistered leaves from such as have been made to contract by the bite of the aphids.

“ The moths appeared as abundant as in the preceding year ; and I then caused my trees to be washed once in every week during a month, after I witnessed the first appearance of the moth, with a weak infusion of tobacco in water : this mode of treatment proved successful, and the foliage of my pear trees, and some plum trees contiguous, escaped all injury. The moths were, however, only driven away ; for the leaves of two pear trees which grew at some distance were almost wholly destroyed, and the foliage of the medlar and cherry trees in the vicinity sustained a good deal of injury from them. Nearly all the leaves which contained any of the larvæ were collected and burned, and comparatively very few of the larvæ escaped ; and I do not at all doubt but that, by adopting the same measures next year, I shall succeed in securing my pears from future injury.

“ There is another species of insect which frequently injures the pear tree, whose depredations are less visible, and consequently less known to gardeners. It has greatly the appearance of an aphid, and is found dispersed over the under surface of the leaves whilst young, and is always immersed in a globule of honey ; in their more mature state these insects are found congregated round the base of the buds, particularly those which are calculated

to form blossom buds. In this, as in their first situation, they emit much honey, and the transmutation of the leaf bud into a blossom bud is prevented. A large number of humble bees and wasps are always attracted by the honey ejected by this insect, which will never fail to indicate its presence to the gardener. It is in size a little less than the black aphid usually seen upon the cherry tree, and its colour, when it is young, is a dull green, with dotted lines of pale brown; and in its mature state its colour is dark brown, with transverse stripes of green across its back. The colour of the male, which is winged, is nearly black, except the upper part of the abdomen, which is a dull flame colour. It is (as Mr. Curtis informs me) the *Psylla Pyri* of Linnæus. I noticed it in the garden here about forty years ago, when it rendered all the crop of pears perfectly worthless. I have subsequently pointed it out to gardeners in other situations; and I suspect that it often exists unnoticed, and greatly injures the quality of the pear. I washed my pear trees with an infusion of tobacco in the spring, which appeared to have destroyed the insects; but they appeared again in great numbers, and the frequent use of the engine did not prevent their doing considerable injury. Not improbably an infusion of the green leaves of either the *Nicotiana Tabacum* or *N. rustica*, which might have been obtained at a very small expense, would have destroyed or driven them off, but it did not occur to me to try it."

15. *Notice of the most remarkable Varieties of Fruits sent to the Society since 1831.* By Mr. Robert Thompson.

Apples. Two seedlings, the one called Maclean's Favourite, and the other Sudbury Beauty, were raised by Dr. Allan Maclean of Colchester: the former is described as one of the finest dessert apples known; the latter is a very handsome table apple, resembling a well-grown Downton Pippin.

"On the 18th of October, 1832, John Williams, Esq., of Pitmaston, sent some fruit of the Golden Pippin grown on the common stock and on the Siberian crab stock, accompanied with the following remarks. 'Walking through the garden of a friend in Worcestershire two days ago, some yellow ripe golden pippins took my eye; these were growing on a tree I recommended, three or four years ago, to be worked with the Golden Pippin, and which was a healthy stock raised from the Siberian crab. The grafts were taken from an old espalier, grafted on the common crab, in the same garden. The difference in the degree of ripeness of the fruit was most remarkable.

"When the truth of preconceived theory is confirmed by the result of actual experiments, it affords great satisfaction to the mind. I refer to my paper published some years ago, in which I recommended the Golden Pippin apple to be grafted on the Siberian crab root and stock; I say root and stock, for some have absurdly regrafted the Siberian crab obtained from nurseries which had been worked on the common apple or crab stock: of course this could have no effect.'

"The Golden Pippins from the Siberian crab stock were firmer, more yellow, and richer, than those grown on the common stock."

Pears. Uvedale's St. Germain. A fruit of this variety, from the garden of Mrs. Chalmers of Feversham, weighed, when gathered, 3 lb. 3½ oz.; in the beginning of December, 3 lb. 2 oz.; and in the end of the same month 3 lb. "In October, 1832, specimens of the Monsieur le Curé pear were received from M. Vilmorin of Paris, in order that they might be compared with the St. Lezin, to which the former had erroneously been made a synonyme. It was found to resemble the St. Lezin only in size and form, and proved a very superior fruit to it; being, instead of a tough stewing pear, a valuable dessert one of first-rate quality. . . . In a letter received from M. Vilmorin in January, 1835, the following note is given respecting it:—'After repeated verification, the Monsieur le Curé pear, or Monsieur, as it is now abbreviated, or Poire de Clion (the name to be preferred), is decidedly different from the St. Lezin, and greatly superior to this last sort.' On November 4. 1833, a box

was sent to the Society, by the late John Wynne Griffith, Esq., containing specimens of twenty-four sorts of pears, from his garden at Garn in Denbighshire; with a statement that they were from grafts received from the garden of the Society in 1830, worked on branches of four old trees, viz. brown beurré, crassane, autumn bergamot, and jargonelle, which were growing against a south-west wall, and the grafts brought over to the south-east side. The sorts were all true to their names, and very well grown. From an account of the number of fruits produced, it appeared that upwards of ten dozens had been obtained in the second year after grafting, and more than thirty dozens in the third year, from the grafts on these four trees; a proof of the rapidity with which a supply of good pears may be procured under favourable circumstances.

“*Grapes.* On the 9th of November, 1831, a bunch of White Muscat of Alexandria grapes was received from John Williams, Esq., of Pitmaston, grown on the open wall, on a south-east aspect. A ligature of waxed string was tied tight round the stem in April, which was found nearly as beneficial as ringing, and less injurious to the future health of the tree.

“On the 2d of January, 1833, fruit of the Charlesworth Tokay grape was received from the Hon. William Booth Grey. Bunch large, long and tapering, rather loose; the shoulders moderately strong.

“On the 24th of February, 1834, the following communication was sent to the Society relating to the Nice Black Cluster grape; fruit of which was subsequently received.

““The Nice Black Cluster, I have no hesitation in saying, if planted against southern walls facing any point between s. e. and s. w., or against the fronts of houses or trellised to balconies, will ripen in ordinary seasons at London, by the end of September or beginning of October, sufficiently for the purpose of making wine of the nature of champagne, and much better than half the champagne sold in London. But for this purpose I recommend to use the pure juice only, without any admixture of sugar and water, or brandy. It is also an excellent grape for a cool late forcing-house, not being liable to rot; nor do the berries wither so much when kept late on the plant, as is the case with many other kinds: this is rather an unusual circumstance, considering that it is not a fleshy grape. It is remarkably juicy, and the seeds readily separate in the mouth without trouble. I only gathered the last from my grapery three days ago, and they were still very juicy, notwithstanding the dry heat and ventilation they were exposed to from the daily fire in the flue, made in order to prevent their rotting. By reference to the long article on Grapes cultivated in Burgundy, in Miller’s *Gardener’s Dictionary*, you will observe the finest Burgundy is made from a variety of the Auvernat grape, having its bunches formed with loose berries: but, owing to the tenderness of the grape, planters in general, for the sake of quantity at the expense of quality, cultivate the more hardy sorts with crowded berries. Now, I have reason to believe my seedling grape is as hardy, with the advantage of loose berries, as the common crowded Auvernats; and for this reason I wish to have it tried in France.’

“The bunches were loosely formed with regularly middle-sized berries, which, from not being overcrowded, were thoroughly ripened and sugary; and on this account it seems highly deserving of cultivation.

“*Strawberry.* On the 5th of July, 1831, fruit of Myatt’s Pine-apple strawberry was exhibited by Mr. Joseph Myatt, Manor Farm, Deptford. Fruit as large as the old pine, oblong, with a neck, and having the calyx spreading or reflexed.” It is added, that this variety produces but sparingly in many soils, on which subject see p. 302.

“*Gourds.* On the 21st of December, 1831, a very large gourd, the Potiron Janne, was presented for exhibition by Mr. Carpenter, from the garden of the Rev. H. Wise, Offchurch, near Leamington [a descendant of Mr. Wise, gardener to Queen Anne]. Its weight was 153 lb., and it was one of a crop weighing altogether 555 lb. from the same vine.

“ On the 21st of October, 1834, a gourd of the same variety, but of a size still more enormous, was exhibited, from Lord Rodney. It was 8 ft. in circumference, and weighed 212 lb.”

16. *On the Grafting of Vines.* By Mr. William Gowans. Communicated by the Horticultural Society of Glasgow. Read June 7. 1836.

This communication, somewhat varied and enlarged by its author, has appeared in the *Gardener's Magazine* for 1837, p. 117.

17. *Upon the supposed absorbent Powers of the Cellular Points, or Spongioles, of the Roots of Trees, and other Plants.* By Thomas Andrew Knight, Esq., F.R.S., Pres. Read May 17. 1836.

“ An opinion is very extensively, if not generally, entertained, that the nutriment which trees and other plants derive from the soil in which they grow is exclusively taken in by the cellular extremities of their roots, which, from their texture, have been called spongioles, and which, in their organisation, differ from other parts of the root in being totally without any alburnous or woody matter distinct from bark. But it is through the alburnum alone of trees, as I have proved by a great variety of experiments, and as is, I believe, generally admitted, that the ascending sap, under ordinary circumstances, passes up from their roots into their branches and leaves; and, as this substance does not exist in the spongiole, my attention was directed to an enquiry, whether the spongioles possess the power of transmitting fluids, and, if such power were found to exist in them, through what peculiar channels such fluids pass up: and as these questions are necessarily interesting, and to some extent, in particular cases, may become important to the practical gardener, I communicate the result of my experiments.

“ Spongioles are obtainable in the most perfect state from large seeds, such as those of the common or French bean, which have been permitted to germinate, by simply detaching them from the cotyledons, as they thus remain united to the cædix of the plant, and its bud and plumule. Many of these were obtained from the seeds of plants of several kinds, and subjected to various modes of treatment in soils of different qualities; but all perished without a single plumule having expanded, or having apparently received any nutriment, either from the soil or other source. Yet the spongioles, in these cases, must have contained greatly more living organisable matter, derived from their cotyledons, than the whole body of the seed of a very large majority of plants can possibly contain; but they were, I conclude, incapable of transmitting it into the plumules, owing to the want of alburnum.

“ I therefore believe my opinion, that spongioles are imperfectly organised parts of the plant, which neither absorb from the soil, nor transmit fluids of any kind for the service of other parts of it, to be well founded: but alburnous matter is generated with great rapidity within them; and they become to a very great extent transnuted into perfect roots, long before the growth of the stem or branches of the tree commences in the spring; and by these newly formed roots (but not by these exclusively) I conceive that nutriment is absorbed from the soil and sent up into the leaves, to be there converted into the true sap of the plant. I am aware that the above-stated opinions are in opposition to those of many eminent physiologists, to which much deference is due; but I think that they have erroneously included within their spongioles portions of alburnous fibre, a substance never found in the organ properly called a spongiole.”

18. *Observation on a Seedling Pear, raised by Thomas Andrew Knight, Esq., called the Althorp Crassane.* By Mr. Robert Thompson. Read Jan. 19. 1836.

This variety, Mr. Thompson observes, will bear competition with the finest of the varieties introduced from Belgium or France. It bears well as a stan-

dard; and the flesh is buttery, rich, and very high flavoured. It is in perfection in the end of October and during November.

19. *On the Cultivation of the Bignonia venusta.* By Mr. George Phillips, Gardener to the Misses Trevor, Tingrith, near Woburn, Bedfordshire. Read Dec. 1. 1835.

Two plants of this splendid hot-house climber are planted in the back corner of the bark bed, in a mixture of turfy loam, leaf mould, and peat, while the roots have the whole range of the bottom of the bark bed in a thin layer of rotten tan, which is not disturbed when the tan is turned. The shoots are trained under the glass, and cover a surface of 500 ft. The plant continues in flower from the beginning of November to February; after which it is cut back to one stem of 6 ft. in length. In 1835, this stem, at the point of amputation, was 4 in. in girth. "From the point where it is cut back, young shoots soon push out in abundance; three or four are selected for training, and the others taken off. If young plants are wanted, this seems to be the most favourable season for propagation; when the shoots are from 6 in. to 9 in. long, they will readily strike root in any light soil in a bottom heat. The young plants may be grown to a large size the first season by frequent shifting, as they are fond of plenty of room for their roots."

20. *On the Cultivation of Alströmérias.* By Mr. W. Scott, Gardener to Charles Barclay, Esq., M.P., F.H.S. Read February 2. 1836.

"Being very partial to the genus, although I had never seen any of the varieties before, except *Ligtu* and *Pelegrina*, I began, when I first came to live at Bury Hill, in April, 1831, immediately to turn my attention towards them. Being well aware, from what I had seen of the two kinds with which I was acquainted, that they require rest for a few months in the course of the season, I removed all the plants I could find (which, as well as I can recollect, were *Hookeri*, *pulchella*, *pallida*, *pelegrina*, *acutifolia*, *pelegrina alba*, *psittacina*, *edulis*, *Ligtu*, and a variety from Mr. Nuttall, raised by him from Peruvian seeds, and which had never flowered here) to a small pit in front of the pine-stove, giving them no water till the earth about their roots got quite dry; as soon as they began to recover, I potted them in the size called forty-eights, and kept them then on a shelf against the back wall of the greenhouse, about 3 ft. from the top-lights; and, although I lost *Hookeri*, *pelegrina alba*, and *edulis*, I had the satisfaction of seeing the others thrive much better than they had done the previous year. I also took up, from the border in front of the stove, *tricolor* and *pulchella*, and gave them the same treatment. When the leaves began to decay, at the end of July or beginning of August, I withheld water, and allowed the plants to rest until the beginning of November, 1832, when they again began to vegetate: I then repotted them, and gave them every encouragement, in rich mould, composed of loam, rotten dung, and leaf mould, with a little sand: this I find to be the best compost for growing them in. As they filled their pots with roots, I shifted them progressively to a larger size; and had, in June, 1833, the pleasure of flowering the species from Mr. Nuttall and *pallida*, for the first time since they had been at Bury Hill; and I succeeded in growing *tricolor* to the height of 2 ft. 3 in., well covered with flowers. None of my pots that season were larger than what are termed sixteens. When the flowering was over, and the leaves were beginning to decay, I again resorted to the plan of drying or resting the plants till the following November. I afterwards gave them the same course of treatment as before; but, as the roots had attained a greater degree of strength, the size of the pots was enlarged, until some of the stronger varieties were planted in the size No. 6, in which they arrived at the state in which they were exhibited at the Society's Garden in June, 1834. During the time of growing, I kept them on a shelf, or trellis, in front of the greenhouse, having upright lights about 5 ft. high, and I give them plenty of air, carefully avoiding the least application of heat, which would draw them

up weak, cause the flowers to be much smaller, and very much injure their colours. By these means I have had them continue in good bloom for full four weeks."

21. *On the Means of destroying the Red Spider in the Melon Frame.* By Thomas Andrew Knight, Esq., F.R.S., Pres. Read May 3. 1836.

"The red spider is one of the most formidable enemies with which the gardener has to contend, and against which he is least well prepared with the means of defence. His peach and nectarine trees upon the open wall are often considerably injured by it; and the conservatory, the forcing-frame, and the stove, scarcely present a plant which is not subject to suffer from its attacks. When it appears upon trees growing upon walls in the open air, and wherever water can be abundantly applied without material injury to the plants, it is easily destroyed; but there are, I believe, comparatively few plants which are not much injured by having the lower surfaces of the leaves much wetted. In a former communication I stated the destructive effects upon the melon plant of the application of water to the under surfaces of the leaves, apparently owing to the cells of that surface of the leaf having absorbed the lighter fluid, in the manner pointed out by M. Dutrochet, and transmitted into the denser fluid the vital sap of the plant.

"The aversion of the red spider to sulphur, or its inability to live in the close vicinity of that substance, has long been known to gardeners; and the object of this communication is only to point out a more efficient mode of employing it than has, I believe, hitherto been practised. The instrument which I use bears a very close resemblance to those employed in fumigating with tobacco, but it is filled with pieces of the wing feathers of pigeons or poultry, amongst which a small quantity of flowers of sulphur is dispersed. The receptacle is then closed with a lid, the front surface of which is perforated with many small holes, through which the air impelled by the bellows passes, carrying with it a portion of flowers of sulphur. By shaking the bellows, the feathers are made to change their position, by which many successive portions of flowers of sulphur are made to escape, till the whole which the receptacle contains is expended.

"I first employed this instrument in the last summer in my melon-house, in which, upon some of my plants, I observed a large number of red spiders. After using it, I noticed with a lens in the web an immensity of minute particles of sulphur, in company with a very large number of red spiders; but upon examining my plants three days afterwards, I found the particles of sulphur alone remained, and that the red spiders had either died or marched off. I found no difficulty in causing many minute particles of sulphur to adhere to the under surfaces of the leaves of all my plants, and during the remainder of the summer I was not able to find a single red spider upon them.

"The form of the instrument for melon plants growing in hot-beds requires to be considerably altered; and the perforations for permitting the escape of the flowers of sulphur should be lateral, instead of being in the front of the lid: that should be made slightly conic, and of less width than the receptacle, so as to come within it to a small depth; by which means the whole of the flowers of sulphur that escapes will be impelled forwards. The apertures should be confined to one side of the lid, which should not sink wholly into the receptacle; and through such apertures the flowers of sulphur will be made to escape below the level of the leaves of the melon in the common frame, and be dispersed over the under surfaces of its leaves.

"I applied flowers of sulphur in several other cases in the last summer, and always with success; and I am applying it to my peach-house and vinery, instead of water from an engine, and I have reason to believe with perfect success.

"My friend Mr. Williams of Pitmaston has perfectly succeeded in banishing the red spider from his melon-house, by causing sulphur to evaporate from

the hottest part of his flues; but, I think, not without some ill consequences. His machinery is a good deal superior to mine, and his skill and science in no degree inferior; but his melons, though very large, and apparently perfect, are generally much surpassed by mine in richness and flavour. When sulphur is made to evaporate, some uncombined acid flies off, and this Mr. Williams suspects (and I agree with him in opinion) to operate injuriously upon the health of his plants. It seems probable that the same uncombined acid would cause the flowers of sulphur to operate injuriously; but, though I have often applied it in large quantities, I never witnessed any ill effects."

22. *Meteorological Journal, &c., for the Year 1836.* By Mr. Thompson.

23. *An Account of some further Experiments made in the Garden of the Society, in the Year 1836, relative to the Cultivation of Potatoes.* By Mr. Robert Thompson. Read December 6. 1836.

This paper, as containing not only original experiments made in 1836, but a summary of all those made in 1831 and 1832, is by far the most valuable that has appeared on the subject of the Potato in these *Transactions*.

"In the year 1831, experiments were made with the view of ascertaining the effect of planting the sets of potatoes much wider apart than usual, in order to give the foliage a greater exposure to light. Whole tubers were accordingly planted in spaces containing 16 sq. ft. The result was, that strong-growing sorts, including a number of Mr. Knight's seedlings, produced fully an average, whilst a few gave a very great crop. But although one of the latter produced at the rate of 21 t. 13 cwt. 59 lb., a weak-growing sort produced only 1 t. 5 cwt. 92 lb. The vigorous could avail themselves of their ample space, which they occupied with their stems and foliage to the full extent; the weaker could not. Hence the propriety of suiting the distance of planting to the vigour of the sort. [See p. 396.]

"In the year 1832, experiments were made with regard to the relative produce of sets from whole tubers, and from single eyes. The result was in favour of the latter by upwards of 7 cwt. per acre, and considerably more on comparison of the clear produce after deducting the weight of sets employed in both cases. [See p. 347.]

"The trials of 1831 gave rise to further experiments with regard to the space between the sets. Accordingly, in 1834, another experiment was made, for the purpose of ascertaining the most preferable distance at which the sets of commonly cultivated varieties should be planted; and at the same time a repetition was made of the comparison between whole tubers and single eyes. The distances between the rows were $2\frac{1}{2}$ ft., 2 ft., $1\frac{1}{2}$ ft., and 6 in. The result with regard to distance was, that the crop was found to be greatest where the distance between the rows was most in accordance with the height of the stems; and the most uniformly abundant produce was from rows 2 ft. apart. The comparison between whole tubers and single eyes was still found to be in favour of the latter.

"The experiments in the present season [1836] have been made with regard to

"First, the time of planting; first week in March, and first week in April.

"Second, the sets; whole tubers, bases, and points of tubers.

"Third, the depth; 3 in., 4 in., 6 in., and 9 in.

"A piece of ground in the kitchen-garden, which was previously in grass, was trenched and planted with the bread-fruit potato, a sort which for productiveness is, perhaps, unequalled near London by any other of so fine a quality. The ground was divided very exactly into six equal parts. Three of these were planted respectively with whole tubers, bases, and points of tubers, in the first week in March; the other three compartments in a similar manner, in the first week in April. The following table exhibits the results, calculated for an acre:—

Time of Planting.	Sets.	Weight planted	Weight taken up.	Deduct weight planted for clear produce.
		t. cwt. lb.	t. cwt. lb.	t. cwt. lb.
1st week in March.	Whole Tubers	1 11 22	15 2 45	13 11 23
	Base of Tubers	1 0 89	15 6 108	14 6 19
	Points of Tubers	0 10 44	18 1 28	17 10 96
	<i>Aver.</i>	1 0 89	16 3 60 $\frac{1}{3}$	15 2 83 $\frac{1}{3}$
1st week in April.	Whole Tubers	1 11 22	15 14 74	14 3 52
	Base of Tubers	1 0 89	14 11 18	13 10 41
	Points of Tubers	0 10 44	14 8 74	13 18 30
	<i>Aver.</i>	1 0 89	14 18 18	13 17 41
Difference in favour of the March plantation				1 5 42 $\frac{1}{3}$

“ It appears from the above, that the March plantation exceeds that of April by 1 ton 5 cwt. 42 $\frac{1}{3}$ lb.; and farther, that the average produce of the points of tubers exceeds that of whole tubers by 1 ton 16 cwt. 87 lb., and of the base of tubers by 1 ton 15 cwt. 94 $\frac{1}{2}$ lb. Consequently, the lowest produce is from the whole sets; a little above the latter is that from the base; and the points of the tubers rank considerably above either. This superiority appears to take place in the March planting; for of those planted in April the whole tubers had the advantage with regard to produce.

“ Sir George S. Mackenzie obtained a different result from different parts of the tuber. Cuts from the base gave a return of 26 lb., middle 20 $\frac{1}{2}$ lb., and points 24 lb.; but, from the following communication, it appears that he was not fully satisfied in regard to the experiment having been fairly made.

“ The experiment, the result of which I communicated last year, comparing the respective produce of the cuts taken from the root end, the middle, and the rose end of a potato, was made, as I mentioned, by the gardener then in my service. Last spring I directed the experiment to be repeated; but my gardener misunderstanding me planted root-cuts, &c., from different potatoes of one sort, instead of all the cuts to be compared being from one tuber. The result is as follows:—

‘ Root-end cuts, 26 lb. Middle, 20 $\frac{1}{2}$ lb. Rose, or crown end, 24 lb.

There were 20 cuts of each sort planted at the usual distance, and a single eye in each cut. Though this does not give a strict comparison of cuts from one tuber, yet it may be regarded as giving a fair mean result. The inferiority of the middle cuts is remarkable; and it appears of some importance to repeat the experiment with different varieties of the potato, attending carefully that only one eye shall be in each cut. When the eyes are crowded, as in the crown, or rose, end, they should be all cut away but one. I am aware that it has been the universal opinion that the crown end is the most productive; but this appears to have been taken for granted, and not deduced from experiment. The great number of eyes, also, at the crown end, may have contributed to an increased produce. In planting a field it is always advantageous to have at least two eyes, lest one should be cut off by frost.’

“ In order to try the effects of different depths of planting, a quarter was divided into four equal parts, and planted with sets in the second week in April, at the respective depths of 3, 4, 6, and 9 inches. The results computed for an acre are as follows:— At 3 in., 13 t. 14 lb.; 4 in., 14 t. 1 cwt. 18 lb.; 6 in., 14 t. 11 cwt. 4 lb.; 9 in., 13 t. 11 lb.

“ The greatest produce was from the plantation at 6 in. deep; and next to it, from that at 4 in. Those planted only 3 in. deep gave the least return.

Many of the sets buried 9 in. did not vegetate, or at least failed in reaching the surface. This was also found to be the case by Hasler Hollist, Esq., in 1835, when he adopted the mode of deep planting. The results of his experiments are detailed in the following note:—

“ I have this year renewed my experiments on the potatoes you sent me in 1833 from Mr. Knight's collection.

“ I planted in the latter end of March, and at intervals during the whole month of April, but I am satisfied I was, contrary to the received opinion, too early in some instances, particularly with Mr. Knight's No. 2.

“ I also planted at various depths, 9 in., 7 in., and from 5 in. to 6 in. In nearly every instance the shallow planting has succeeded, but in none the deepest, and in the latter case many of the sets have not vegetated at all, many more have not reached the surface.

“ A few single eyes of the Downton Yam, literally parings, have yielded very nearly as much as the full-sized sets. I think I could say quite as much if the tubers from which they were cut were added to their actual produce.

“ Some of these statements appear so singular that I feel a hesitation in mentioning; them but, whether from the unfavourable season, mismanagement, or what other cause I know not, certain it is, that these are my results.

“ P.S. The soil is a loamy sand, and friable.”

MISCELLANEOUS INTELLIGENCE.

ART. I. *General Notices.*

INFLUENCE of various Circumstances in the Growth of Plants in modifying their Physiological Action. Extracted from a paper by Dr. Christison, read before the Royal Society of Edinburgh, Feb. 3. 1840.—“ The author commenced with some remarks on the various causes by which the action of plants and of their products on the animal body may be modified, and on the great vagueness and uncertainty of the information at present possessed in regard to the influence of those causes which seem to arise in peculiar circumstances of vegetation, more especially climate, weather, soil, and the progress of vegetation. He then stated the sources of information on these points; namely, the curative or therapeutic action of drugs on man, their effects on the healthy function, both of man and animals, either as medicines or as poisons, their sensible qualities, and their chemical analysis; and he assigned reasons for discarding the first of these from the enquiry, and for trusting, in a great measure, to the criterions derived from sensible qualities, from the effects of poisons on the lower animals, and from chemical analysis.

“ The remaining part of the present paper was confined chiefly to the influence of the progress of vegetation on the activity of plants. Doubts were thrown, by the results of his investigations, on most of the current doctrines on this head; but the present state of the enquiry did not lead to any general inferences being drawn with confidence.

“ An extended statement was made upon the influence of the progress of vegetation upon many of the active species of the natural family Ranunculaceæ. It was stated, that in the acrid species of the genera *Ranunculus*, *Anemone*, and *Clematis*, the acridity, which is the same throughout them all in quality, is possessed in nearly equal activity by the leaves, from an early period in the spring until they are about to decay; but that it exists in the germens only while they are green, and disappears there entirely as the seeds ripen. In the acrid species of *Aconitum*, the acridity of the leaves, on the contrary, continues only until the seeds begin to form, and then gradually, but quickly, disappears as they ripen, while the seeds acquire precisely the same peculiar kind of acridity. The narcotic properties of the leaves, however, do

not undergo the same singular change, but continue undiminished after the seeds are mostly ripe, and probably, indeed, as long as the leaves themselves retain their freshness. The acidity of the genus *Helleborus* is probably governed by circumstances different from any of those already mentioned; but the experiments already made are insufficient to point out the true rule. In the course of these observations many remarks were also made on the nature of the acidity possessed by the different species, upon which incorrect ideas at present very generally prevail; several material corrections were also suggested as to the general opinions respecting the influence of heat, desiccation, and time upon their acidity; and a short allusion was made to the properties of a remarkably crystalline principle which the author discovered in one of the species of *Ranunculus*, and which appeared to him to be the ingredient upon which the activity of that genus depends.

“The author next entered into some details regarding the influence of the progress of vegetation on narcotic plants, and commenced with the natural family *Amygdaleæ*, the leaves of several of which are eminently poisonous, in consequence of containing, or producing when bruised, a hydrocyanated essential oil. He showed that this oil abounds most in the leaves of the cherry laurel (*Cerasus Lauro-cerasus*), when they are young and undeveloped; and that it goes on diminishing gradually in proportion to their weight, as they increase in age and vigour, until the commencement of their second season, when the old leaves, though plump and luxuriant, do not contain above an eighth or tenth of what they contained in the infant state, or of what is contained in the young undeveloped leaves of the same period. This is a complete reversal of the generally admitted law in respect of the formation of volatile oils in leaves.

“The consideration of this fact led to some statements upon the mode and form in which some essential oils and other active principles exist in the leaves of plants; and the conclusion was drawn, that in all probability many active principles, which are separated from plants by simple processes, do not exist ready-formed in the leaves; but, as in the familiar case of the mustard seed and bitter almond, are only developed when the structure of the leaves is broken up, and principles of a different kind, secreted in distinct cells, are brought in contact with one another or with water.

“The remaining departments of the investigation were postponed; but further observations were promised upon the influence of the progress of vegetation on the solanaceous and umbelliferous plants, and likewise on the effects of soil and climate.”

From the above extract it may be gathered why cattle reject the *Ranunculus acris*, or common buttercup of the meadow, while green, but do not object to it, but are even said to be fond of it, in a state of hay. — *Cond.*

Temperature of Plants. — M. Dutrochet, some years ago, proved by experiment that living plants have a proper heat; and other experiments have recently been made by M. Van Beck, and read to the French Academy in January last, confirming the fact. The maximum of inherent heat which M. Van Beck found, on September 29th, an hour and a quarter after noon, in a young leaf of *Sedum Cotylèdon*, was about 0.25° centigrade, or about something more than half a degree of Fahrenheit. In rainy and dull days the heat was not so great as when the weather was calm and clear. The following observations are interesting, as tending to show the probable advantages of a free circulation of the air among plants; though, as the writer observes, the subject requires to be farther examined.

“A singular phenomenon, which I have always observed in the course of my experiments, is, that, on suddenly raising the bell-glass which cut off all communication between the air of the apartment and that of the plant, the heat of the latter always rose suddenly some tenths of a degree. This phenomenon, however, lasted only a few minutes; the magnetic needle soon retrograded, passing zero of the scale, and showing, by its opposite and permanent deviation, that the living plant had a much lower temperature than the dead leaf, as is always the case in the atmosphere.

“Is this phenomenon to be ascribed to the instantaneous access of the free air to the plant, which, by stimulating its vital functions, which were depressed by its having been kept in a less pure air, augments at the same time its proper heat, before the counteracting and frigorific influence of reestablished evaporation has had time to make itself felt?”

“This I cannot venture to decide; but I hope that other philosophers and naturalists will engage in these researches, which, if I am not deceived, may yet throw light on many an interesting question in vegetable physiology.”

(*Compte Rendu*, &c., as quoted in *Jam. Jour.* for April, 1840, p. 333.)

The Effect of Light passing through coloured Glass on Plants (p. 301.) is a subject worth deep attention, and opens a wide field for observation. Some time ago I had two pine stoves darkened with hot lime and water, with a little size to make it stick on. I did this to save the trouble of constantly shading, and I find it not only to break the rays of the sun, but that in very bright days it was scarcely necessary to give air. The question is, whether a dark colour would not be better than this whitewash? It is well known that pines can be grown faster in summer in pits glazed with dark green glass than in houses covered with clear glass; and I have no doubt but that a coloured mixture to darken the glass through the middle of summer would prove highly beneficial to the pine. However, I will try the experiment on one house.—*John Spencer. Bowood Gardens, June 4. 1840.*

A new Cedar.—If the accompanying extracts and remarks should arrest the attention of any traveller who can procure seeds, or rather cones, from the trees mentioned, he may discover a new cedar; at any rate, he will earn the commendation of scientific men, if, by forwarding such seeds to England, he will enable us to ascertain precisely the trees referred to.

“From Debaree are seen the trees which surround the church of Tcham-belga, which Bruce took for cedars, and Salt (at Taranta) for firs; but they resemble neither the cedars of Lebanon nor the firs of Europe; it is rather a mixture of both, with thorns (?) even more tender than those of the cedar; but its fruit resembles altogether the fruit of the juniper tree: it is almost the only wood for building that there is in Abyssinia.” (*Gobat's Abyssinia.*)

The place to which I imagine Gobat refers is, in Salt's *Voyage to Abyssinia*, 4to, p. 236., “a bed of chalk-stone; and wherever this prevailed an extensive grove of a hardy kind of cedar, called Tûd, flourished in abundance.”

I have also lately met (but cannot remember where, [in the *Transactions of the Geographical Society of London*]) with the assertion, that on the “Cedar Mountains,” Cape of Good Hope, are abundance of the cedars of Lebanon. And, in an account of the Madeiras (from whence it would not be difficult to procure cones), it is said that the forests formerly covering the islands have disappeared; save that in the remote parts of the mountains we may still occasionally meet with “a species of cedar.” Were I to indulge in conjecture, I should guess the tree mentioned by Salt and Gobat may be nearly allied to, or identical with, the cypress of Goa (*Cupressus lusitánica*). I would add that Abyssinia, approached now so speedily and easily, and where Europeans, and particularly Englishmen, have little to fear, presents a most tempting field to the practical botanist; offering, as it does, a vegetation of the utmost variety, from the tropical productions of the valleys to the lichens of its snow-clad mountains.—*W. H. W. Derby, Feb. 20. 1840.*

Beaumóntia grandiflora.—If the reader will turn to p. 236. of this volume he will see a speculative notion of mine for flowering the *Beaumóntia grandiflora*. This old-fashioned plant is very unwilling to flower with us in the stoves, and, if treated as a green-house climber, it soon gets stunted and never flowers at all. This was a great favourite plant with my much lamented late employer, W. Gordon, Esq., of Haffield, and we tried many experiments with it there for nine or ten years to get it into flower, and only succeeded once. It was among the first plants that I tried at Kingsbury, in the way of experiment. I planted it out into a border in the orchidaceous house which runs at the back of the conservatory, and for the first season I trained it in the same house. In the spring of 1839, I introduced the head of it through the back

wall into the conservatory where it had plenty of space to run along, and it made great progress during the season. Last winter it was kept in the conservatory, and within a few inches of the glass; but it did not seem to be in good humour, for three or four months; yet it kept its leaves and young shoots in their natural colour, and about the middle of last May it showed strong flower buds on the ends of the last season's wood, and now some of the flowers are expanded, and beautiful objects they are. The flowers have long tubes like those of the *Brugmansia*, and wide undulating limbs like the flowers of the *Brunfelsia undulata*, and are of the colour and texture of the flowers of the *Magnolia grandiflora*. You must excuse this homely way of describing its flowers; it will answer the purpose I have in view better than a long string of Latin adjectives. These flowers are produced on the very top of the side shoots in clusters, one or two only opening at a time, so that each truss keeps a long time in flower. For my own part, I like large flowers and large foliage, especially for climbers, and I can never make up my mind to the papilionaceous climbers from the South Sea Islands, as conservatory climbers: their flowers are generally so small as to be lost in a lofty house; they are much better fitted to be grown in pots, and trained into fancy shapes. The *Beaumontia*, treated in this way, will be a great acquisition to the conservatory climbers; and if it will prove a regular flower under this system, no plant can be more deserving of a place. The amateur and young gardener must bear in mind that it flowers on the ends of last year's wood, and they must not shorten these till after the flowers are over. I was too ambitious last summer to get my plant to run as long as possible, and for this purpose I repeatedly pinched off the tops of the strongest lateral shoots; these, of course, do not flower this season, but, being cut in to one or two eyes, they will make good flowering shoots for next season. If I had more time [which we hope you will soon have] I would mention several other old plants which I think might be tried in this way with advantage. — *D. Beaton. Kingsbury, Kilburn, June 27.*

Mushrooms growing in the same Soil with Truffles. — *Paris, Academy of Sciences, June 16, 1840.* A letter was read from M. Gasparina, stating that in certain parts of the kingdom of Naples the country people had remarked, that, when a certain spot produced mushrooms in great abundance, there were always to be found near the surface of the soil black irregular solid substances, which they called mushroom stones, and which they believed promoted the growth of the fungous plant. M. Gasparina, suspecting the true nature of this substance, examined several localities, and ascertained that they were a species of truffle, sometimes of enormous dimensions, and in one instance attaining the size of a child's head, six or eight years old. This specimen was now produced before the Academy. (*Lit. Gaz., June 20.*)

ART. II. *The West London Gardeners' Association for mutual Instruction.*

MONDAY Evening, March 30, 1840 — Mr. Thomas Keane read his paper "*On the Forcing of Melons,*" which explained his system as follows: "Before I begin the general treatment of the melon, I shall say a few words about the sort of place I would recommend for growing them in, which would be pits in preference to frames. The pit to be constructed 6 ft. in height at the back, 4 ft. at the front, and 5 ft. in breadth. $3\frac{1}{2}$ ft. in depth at the back, and $2\frac{1}{2}$ ft. in front, with both ends the same, would be a receptacle to contain linings of dung, the breadth of which would be 2 ft. 3 in.: the dung, when it ferments, to communicate the heat to the pit through pigeon-holes. This cavity, or dung-container to be covered over with a wooden shutter, hung by hinges to a piece of wood laid on the outside of the walls; and so hinged to the wood as to be easily taken off or put on, for making or renewing linings, or for any other purpose. In the back or north side of the pit, I would have a chamber, or vacant space, of about 4 in. in breadth, worked through it from top to bottom, to cause a circulation of heat to ascend and descend, which, in a great measure,

will assist its temperature in March, April, and May. The angle the pit would form from these dimensions, would be about $67\frac{1}{2}^{\circ}$, which would answer well to carry off the different descriptions of showers that we frequently have, and ought to guard against as much as possible, at this season, together with obtaining the most reflecting rays of the sun, which is one of the most necessary acquisitions.

The melon, from its seed to its proper perfection of fruit, requires due care and attention; as I am certain it often suffers through a want of the proper temperature, free circulation of air, gentle waterings, and syringings occasionally. Firstly, From the time the seeds are sown in pots in the seed bed, until their removal thence to the pit. Secondly, From their entrance into the pit to setting their fruit. Thirdly, From setting their fruit to about a fortnight after. Fourthly, and lastly, From that time to its maturity. These are the several stages in which the melon requires the different agents heretofore mentioned, to be properly applied to it. It is to avoid sudden transitions of temperature at that early season of the year, that I would recommend pits in preference to frames. Let us take notice of the lining applied to a frame a few days after it is lined; and if during some period of that time it has been visited by some cold, frosty, snowy, or cloudy, weather, then try it with your hand and feel how far these different changes will affect it. I expect that you will see it more affected than what it can well bear. Whereas at the same time, and with less dung, your pit lining is buried beneath the influence of all these searching and trying visiters, doing its duty without the necessity of removing it one fourth as often as you should a frame lining.

I prepare my seed-bed about the beginning or middle of February. If I have seed two years old, I prefer it, being riper and less liable to failures; but I find it best to put the seeds into half a pint of milk for about twenty-four hours before sowing, as this process, I think, softens them, and helps to excite the germination of the seeds; putting three in each 48-sized pot, as the less checks of any sort the melon meets with the better.

As soon as the plants are in leaf about the size of a half-crown piece, I always remove them to the pit. I prepare the pots with good drainage, and fill them with the prepared compost, which is composed of the top spit of a pasture field, with one sixth of vegetable soil, mixed together for 12 or 18 months, and, previously to its being used, turned over once or twice, and at each turning having a small quantity of quicklime mixed through it, in the proportion of half a bushel to one horse load, which is a preventive against all kinds of canker, worms, or any thing hurtful to the plant. I fill the pots with it, refining it to suit the seed, and put the seed about 1 in. deep in the soil. These pots are kept in the seed-bed three or four days before sowing, to have them of the same temperature as the bed, which I would always keep between 65° and 70° : the water I use is of the same temperature, being kept in bottles in the pit.

The covering I would recommend at this and every other stage of their growth, to be thatched frames to fit each light, as I have experienced them to be excellent coverings for these or any other plants in pits. They are best to withstand the most severe attacks of any weather; they are in fact cleaner, neater, cheaper, and more easily used, than any other covering I am aware of.

During the time the plants are in the seed bed, I prepare my pit by putting at the bottom a quantity of coarse brushwood, laying it about 3 ft. in height at the back, 2 ft. at the front, with 3 or 4 inches of dung on it. On this I lay turf all over, about 6 or 7 inches thick, as a preventive against rank steam. On the top of this, and around the edges of the sides, about 3 or 4 inches in breadth, I spread about $1\frac{1}{2}$ in. of fine sand, that, after the escape of rank or foul steam through the turf and these crevices, it should come in contact with the sand, which, being of a close quality, purifies it so as to render it quite congenial to the plants. I then give the pit a coat of very thick liquid, made of quicklime, of the consistence of cream; as it will, when syringed, promote vegetation, and cause a vapour to arise destructive to all insects that attack the melon.

When the plants are ready to put out, which will be about the beginning of March, I would plunge them to the level of the surface, or 1 in. below it, then water and shade them from mid-day sun for a fortnight or longer, if they seemed to require it. I should not be inclined to increase the temperature, from that time until they are commencing to set their fruit, higher than 75°.

When the plants have been in the pit about a fortnight or three weeks, I would fill it up to the level of the hillocks with the compost, and would give them water a little once at the roots, with no syringing as they are not strong enough to absorb much moisture; but plenty of air is indispensably necessary to be given at this stage of their growth. As soon as the plants had made their fourth or fifth joint, I would stop them at the third, from which fruit-bearing laterals would be produced, keeping the fruit as close to the main stem as possible, and not allowing the plant to ramble about the pit. If two fruits, through impregnation, remained to each plant, I should be satisfied; if more showed for the first time, I would take them off.

Between the time they begin to make laterals and their setting, syringe the sides of the pit as I have before recommended, at least twice a week, or three times if the weather permit. Most danger is to be apprehended from the time they commence to set their fruit, and for a fortnight after, when they require all the assistance with which they can be supplied. An increase of temperature from 75° to 80°, with plenty of air, will serve to harden the young fruit, cold winds to be excluded: when the fruit is commencing to set, no water to be given to the plant, unless the syringings about the sides. Never to forget covering on any night, and this to be done about 5 o'clock in March, especially after syringing; in April at 6, and in May at 7 o'clock. I consider these hours the best time, but they may be varied a little according to the state of the weather.

At the last stage, to bring them to a good flavour, I would increase the temperature to 85°, with plenty of air, by which I would expect to cut good fruit about the middle or end of May. From the time of setting to the maturation of the fruit, I would not give water to the roots more than twice, as the soil will receive sufficient moisture from the syringings.

The sorts preferred for early forcing would be the Egyptian Green Flesh, the Old Scarlet Flesh, and the Ispahan. They are not of a large size, but excellent in flavour. I beg to state that at the time of applying my soil in the pit to level it with the hillocks, I would press it pretty hard with my feet, as I think it prevents the roots from running through it more than their proper growth requires, and makes it retentive of the portion of moisture which it absorbs from syringings. I would also recommend slates to be laid under the melons, as I have found them to do well, even better, in my opinion, than tiles.

Mr. Caie approved of the application of linings in pits, by which the heat was more regular than if it were exposed to the variation of the surrounding atmosphere, by which it would be more or less affected according to the state of the weather. He approved of lime, when used with discretion, and considered it would be well to enquire how vegetable life was affected by it, that we may know the proper proportions which constitute the soils most suitable for different sorts of plants; and also to examine into the advantages or disadvantages of softening the seed in milk.

Mr. Shearer considered that Mr. Keane's paper opened a fine field for discussion on the melon. He recommended the seed to be sown in 48-sized pots, covered about half an inch deep, the temperature for the seed-bed to be 70°, and when planted out 75°. He preferred to stop the runners at the third joint, and could not see the advantage of shading them at that season when the influence of light was so much desired.

Mr. Sherwood preferred dung beds to pits. He believed that when the roots extended to the old dung they were invigorated to produce strong runners and good fruit.

Mr. W. Keane objected to the use of dung, which excites the plants to produce unproductive runners. The compost he used was good maiden loam, the

top spit taken from a pasture where sheep had been kept; it was repeatedly turned over for twelve months before using, and when chopped small without screening it is the best for retaining the moisture. He observed that a gardener of his acquaintance, who travelled in Persia, where melons are found in the greatest abundance, informed him that they were universally grown upon marshy ground, the surface being matted over with long grass, on which the vines of the melon trailed and fruited, exposed to the influence of a tropical sun, with no rain at that season, but refreshed by heavy dews.

Mr. Caie disapproved of the use of dung, and also of shading the plants. His practice was to sow seeds in pans filled with vegetable mould, then placed near the glass until they were fit to plant out on the hillocks, which were composed of the top spit of good maiden loam left very rough, with the grassy side turned down on the tops of the hillocks. He approved of growing the melon hardy, and considered that old seed, well ripened, was superior to fresh.

Mr. W. Keane differed from the opinions of some gardeners who believed that fresh seed would produce luxuriant runners and male blossoms. He never could notice that fresh seed, well ripened, was less productive; and he was sure that his observations would be confirmed by the experience of many gardeners.

Mr. Fish objected to the system of allowing the roots to extend to the dung. The depth of soil he would recommend to be 1 ft. deep of the top spit of good pasture land, to be earthed up when planted out, by which they were much invigorated. He could never observe any difference in the produce of old or new seed. He would not water the leaves of melons unless to destroy insects; he generally sowed his seeds about the 20th of January, in pans, as recommended by Mr. Caie, and has cut good fruit in the latter part of May. He has produced three crops from the same plants, and always stopped them at the second joint until they showed fruit. He approved of using lime, which is destructive to insects; the temperature, from the germination of the seed to the time of fruiting, to be from 70° to 90°. He believed that dung applied as linings in pits, and covered up, did not ferment so well as the linings more exposed in the dung beds; that many gardeners injured their plants by too much bottom heat; and agreed with Mr. Caie in the advantage of growing them hardy; the soil, if considered necessary, to be enriched by deer or pigeon dung water. He did not approve of brushwood, as the weight of the soil was likely to sink it irregularly, by which the roots would be lacerated.

Mr. Shearer did not doubt but by sowing seed in January fruit could be produced in May. He preferred the depth of soil to be 18 in., and approved of pits for early forcing.

Mr. Caie entered into a lucid explanation of the harmony that exists between animal and vegetable life, to prove that the disease of the plant gives rise to animal life; and that the different colours of hybrid flowers are caused by the quantity and quality of the gases in the atmosphere at the time of impregnation, which at that critical moment gives a fixedness of colour, which afterwards constitutes the distinguishing quality of the plant. He considered it would be necessary to understand the proper proportion of gases, when desirous to perform the impregnation for the object of producing a particular colour.

Mr. W. Keane approved of the observations just made by Mr. Caie; but if not impossible, he thought that it was very improbable, that the gases, being of such a volatile nature, could ever be so well known by a gardener as to induce him to calculate with certainty on the colours to be produced by impregnation. He believed that all the varieties of colours are effected by the chemistry of nature; that the change depends upon a peculiar principle called chromule; and that the changes of colours are influenced by the various oxygenation of the chromule. He recommended the Persian melons as being delicious in flavour, considered the netted and rock cantaloups as the best for the general, and the Romana as a good sort for early crops. He believed that heat from the linings was best communicated by the faggots, and in his experience he never saw the ill effects observed by Mr. Fish. He approved of the use of lime in the proportion recommended by Mr. T. Keane, and also agreed in the

advantage of placing slates under the fruit, which increased the heat by the reflection of the sun's rays from them.

Mr. Fish would recommend the Kew Cantaloup, the Egyptian Green Flesh, and the King's Favourite.

Mr. Thomas Keane, in his reply, combated at length the objections made to his paper, and observed that he particularly detailed the system which he practised with success.

ART. III. *Retrospective Criticism.*

GLAZING with Lead Lap instead of Putty. (p. 299.)—I am induced to send you the following observations, from reading in your last Magazine (p. 299.) some strictures on glazing, by a person who confesses to know little about it; having never practised the system he recommends. The paper in question is signed Amicus, but I beg to state (having seen lead-lap glazing extensively practised) he will prove anything but a friend to whoever may take his advice; in support of which I will state the objections to lead-lap glazing as they occur to me. Suppose then a light 6 ft. long, glazed according to Amicus's plan: each bar will sustain the weight of two lengths of lead lap, which will be a pound weight at least; and, as heavy sashes are at all times objectionable, his method is rendered doubly so, not having strength to palliate or recommend this fault. Again, lead expands greatly with heat, and after a time does not contract to its original position; this will cause the lead and glass between the copper tacks to assume a wavy appearance, which will encourage drip, &c.; and, as the copper nails used cannot be more than half an inch in length, they are very slight, consequently in a short time they become loose both in the wood and lead, by the working of the lights in giving air, &c., which, from hurry or carelessness, is often done with violence, causing considerable concussion. I have seen lights, having been in use only two or three years, in which the nails had become so loose from such causes, that if the lights were turned upon their side, there was danger of the whole of the glass tumbling off the frame. In repairing, the objections are far greater than those used against glazing with putty, as what Amicus states about the difference in the thickness of the glass is mere moonshine. The glass being always bedded in putty, it is easy to insert another square under the one above, without taking off the corners or the square being "precisely" the same thickness; and when properly bedded or back-puttied, it will not be the cause of drip: but in lead glazing, from the strength of the cement necessarily used at first, it becomes exceeding difficult to remove broken squares; the lead by its thinness is always damaged, and often broken; therefore, when repairs are required the lap can never be made to look as before; the glazing is also ineffectual, if the glass be not well bedded in the cement used, and this cannot be done without disturbing the immediate squares above and below the new one, more or less.

About six years since, I witnessed a pine pit, a vinery, a peach house, and some framing, glazed with lead lap, all of which it has been absolutely necessary to alter, with the exception of the bottom lights of the pine-pit, which are at a very acute angle, and fixed to the rafters, notwithstanding which they admit some drips. I may just mention how very superior to the above, or the old method, grooved wooden bars are found to be, in neatness and durability; they also render Amicus's objection, of the putty leaving the bars, "null and void," as in grooved bars no more putty is exposed to the weather than by the lead lap.

I hope the foregoing remarks will be sufficient to convince Amicus of the fallacy of his views, and that they will be taken as they are intended to be.—*Veritas. Derbyshire, June 13. 1840.*

THE
GARDENER'S MAGAZINE,
SEPTEMBER, 1840.

ORIGINAL COMMUNICATIONS.

ART. I. *Remarks and Observations suggested by the Reading of Dr. Lindley's "Theory of Horticulture."* By R. LYMBURN.

THE late work of Professor Lindley, on the *Theory of Horticulture*, is undoubtedly the greatest help that science has hitherto furnished to practice; the scientific part is so clear and concise, so devoid of ambiguity, and so full of demonstration, that no practical man who wishes to excel in his business should be without it. Practical men have, however, a still further duty to perform; they should bring the scientific doctrines to the test of experience. They have many opportunities of detecting circumstances which do not come under the observation of professors. Every new appearance which occurs to them should be diligently weighed and examined; and if any new truth is elicited, or any corroboration or refutation of theoretical principles discovered, they should promulgate their observations for the benefit of themselves and others. Impressed with these ideas, I have ventured to send you the fruits of my observations on the different sections of the practical part of the above work; and hope the example will be followed by others more able to do justice to the subject.

On the first section, on Bottom Heat, I would remark that the colour of the soil has an effect on bottom heat; the black colour absorbs heat most readily, but it parts with it again most readily, and the brown colour is more uniform in its temperature. A great source of bottom heat is the composition of the soil. Silix, being a bad conductor, retains heat, and soils which abound in siliceous sand are much warmer than those which contain sand in very small proportion. In sandy soils, though within a short distance of clayey, vegetation commences some weeks earlier, and the various plants, according to their times of starting into growth, will be generally a month earlier; but very sandy soils part with moisture, and the vegetable food, too freely by evaporation, unless in very wet seasons. The most beneficial source of bottom heat, in the open ground, is the pulverisation of the soil. All soils have a natural tendency to consolidate; the action

of the rain, and the heats and colds of the atmosphere, have a tendency to reduce the inequalities in the soil, and bind it into a solid mass, which is cold and unproductive when compared with soil which has been properly pulverised. If intended for deep-rooted crops, the soil should be broken up to a considerable depth in dry weather, in order that the particles into which the soil is divided, being thoroughly dried, may preserve its open texture as long as possible; confined air is thus generated between the particles of soil, which is the best retainer of heat, as we have all every day experience from the comfortable warmth afforded by our clothes. This confined air retains the heat imparted by the sun through the day, which accumulates and becomes very sensible in all free open soils; and keeps up a higher temperature in the night, thus showing the necessity of bottom heat to all plants wherever grown, it being natural to all good well-pulverised soils. The free admission of atmospheric air is also necessary in the decomposition of the food of plants; by parting with its oxygen, it helps to fix and retain the carbon in the state of carbonic acid, and in the act of separation always gives out heat; and it is also the great source of nitrogen, which chemists have of late more frequently discovered in plants, and which, Dr. Lindley says, is indispensable to the healthy condition of the young spongioles of the roots. To keep the soil open, it must be well drained where necessary, and must be stirred in spring when in a dry state: if broken dry into small pieces, and well dried before heavy rains occur, it keeps open till again flooded with the heavy rains of next winter; the small interstices between the particles are filled with confined air, which retain heat, and moisture is retained by the capillary attraction which water has to the sides of narrow apertures; hence the smaller these particles can be made, if worked dry and kept asunder, the more heat and moisture is retained near the surface. When soil has been some time exposed to the air by digging and turning up in the spring, if the weather is dry and frosty, the freezing of the water contained in the soil causes it to expand; and, if the ground is strong and clayey, it is beneficial in reducing coarse and lumpy soils to a finer texture on the surface: if done in summer, in dry weather, the heat, if considerable, expands the water, and the same reduction of texture takes place, though more slowly, as the expansive power of freezing is generally greater; by degrees, however, the particles, by attrition and the action of the atmosphere, are reduced into small powder, which is washed down by the heavy rains of winter; and the pressure of the soil above consolidates the earth into the same solid mass as we had the year before, requiring to be again opened up in the spring. When ground has thus been operated upon for a succession of years, it will not keep open so well, has a constant tendency to

run to powder on the surface, and get covered with moss; this is what is technically called worn out: the particles will not keep properly asunder, and the ground requires to be trenched, the old surface buried, and a fresh surface brought up; or, where this cannot be got done, where the bottom is bad, to be sown down in grass. In preparing the ground therefore for seeds, if small, we must break the soil into as small particles as possible, and do so in dry weather; if heavy rains occur before the particles are dry, the surface is diluted into a paste, which with the next drought consolidates into a crust, impervious to heat, and if the surface is left rough and lumpy, the heat and moisture are not retained at the surface, which is prejudicial to small seeds that cannot be sown deep; for larger seeds, or for rooted crops, the particles may be left larger and wider apart, as the heat and air are thus allowed to penetrate deeper, and the surface is not so easily skinned. The same remarks will apply to the soil in pots or houses: it must be kept open to retain heat, and if the temperature is properly lowered in the house in the evening, we will have all the advantage of a bottom heat superior to the colder atmosphere, and thus imitate the natural tropical climate. We also see the benefit of keeping the soil open about the roots of large trees: the roots get the benefit of the heat and air, and will not incline to rise so near to the surface; but if the earth is kept solid, they will naturally incline upwards. Stirring the soil in fruit-tree borders should be beneficial, if cautiously done; if the smaller roots only are cut, it is like pruning the young wood of a tree, it stimulates to the greater production of fibres; if large roots are taken away, it is like pruning large arms of the tree, hurtful.

The soil may also be kept open by other means. Manures, and all other substances that decompose in the ground, leave interstices by their becoming of less bulk; and this is one of the great benefits to be derived from manures. The opening of the soil may be carried too far; if the manure is very strong, and not sufficiently decomposed, and the weather dry, it may have bad effects; but if so far decomposed as that it will divide like turf, it is a source of great benefit in keeping the soil open, and retaining moisture, independent of the food it contains: this keeping of the soil open is the great benefit derived from mixing turf in composts, and from mixing pieces of moss with the soil in the act of potting, which is similar; also in mixing peat, old thatch, &c., in composts. So great are the benefits to be derived from decomposing turf mixed with the soil, that I recollect in the case of a piece of old Scotch fir plantation, which surrounded one of our nursery fields, being taken down, and the ground added to the nursery; the turf was trenched down, and so great was the effects, that for some years the ends and corners of the plats

which were added to the old soil were ready to pull a year sooner, in half the time of the rest of the ground; this could not arise from fallen leaves, as the belt was mostly all of Scotch firs; and so perceptible was the difference between the old and new ground, that we could tell the site of the plantation for several years by its effects on all the nursery plants that were grown on it. Most potted plants will grow in very different composts, but require different treatment: in light dry soils they must be more frequently watered, and kept more cool; when more loam is in the compost, they need less attention, and are more hardy, but grow more slowly. For the other great benefits derived from bottom heat, the necessity of suiting the temperature of the soil to that of the atmosphere, the disadvantages of neglecting this in the growing of grapes, the great advantages of keeping the roots warm in forcing, &c. &c., recourse must be had to the work itself.

On the analogous sections, of Temperature, and Protection from Frost, the great effort should be to retain, if possible, the heat which was accumulated near the plants through the day. If water be near, it has a tendency to assume the state of vapour, and rob the air of its heat; the sap of the plant may be more abundant also, from this cause, and increase the expansion of the fluids by frost, which may end in the bursting and laceration of the vessels, and be the cause of death. When a clear cold night succeeds to a wet day, if the night is long, and the atmosphere does not get cloudy, the heat radiates upwards from the earth and plants into the cold air; while the evening at first is comparatively warm. The cold is also greatly accelerated by the evaporation of moisture: it is calculated that it takes above 800° of heat to convert water into steam; and though vapour does not require so much, part of the vapour being chemically attracted by the atmosphere, still the consumption is great. From these causes the earth and plants by degrees get so cold, from having parted with their heat, that their temperature descends below the freezing point. In spring and autumn the air is comparatively warm, and the nights not so long; and hence spring and autumn frosts seldom take place till near sunrise: and if a cloud happens to settle above any portion of the earth about that time, before the earth has been cooled down to the freezing point, it prevents the further radiation of the heat upwards; and hence we often find places lying contiguous and below the cloud to be saved from frost at one time, while at another they will be much hurt. Where plants partially cover one another, they help to prevent radiation; and when one plant is more covered with moisture than another, or growing more vigorously, more full of watery sap, and the bark more tender, from these and other causes one plant is often, to all

appearance, unaccountably killed, while another is left unhurt. In order to protect plants from frost, we should study to have the plants themselves, and the earth around, as dry as possible towards the evening. The situation for plants liable to be hurt by spring and autumn frosts should be as much elevated as possible, in order to have the benefit of the wind in dispersing the cold heavy air and bringing forward the warmer; in low situations, the cold air, being heavier, collects, and not being benefited by the dispersion of the wind and bringing forward of warmer air, plants are much more liable to be hurt by slight frosts in such situations. Wherever possible, when the clearness and coldness of the air indicate a tendency to frost, plants that are worth the expense should be covered with the best nonconducting substance we can fall in with. Metals are the worst; if polished and bright in the colour however they are better non-conductors than when dark-coloured and rough; wood is better; but, unless when saturated with moisture, woollen is the best of any, from the confined air retained between the hairs of the wool. Whatever covering is used, whether straw mats, bast mats, cloth, or wood, they should be elevated above the surface to be covered, so as to contain as much confined air as possible: confined air is one of the worst conductors of heat; the covering will not radiate, or give out heat, till the confined air and covering are both heated above the state of the atmosphere; and the transmission of heat will take place more slowly through the confined air than any thing else: thus, for very little trouble, by elevating our coverings, we surround our plants or plant structures with a substance which is very retentive of heat, and increases the power of the covering in an immense degree. The heat has most tendency to ascend upwards, and this should be most guarded against; but it will also escape by the sides, and to confine the air and heat completely, the plant or plant-structure must be covered all round from the external air. Wall trees should have a broad coping of wood on the wall, to prevent the ascent of heat; and woollen nets drawn before tender peaches, &c., in cold nights, and carefully removed in good weather through the day, are a great help, when not left on in all weathers. The wall is best built of porous materials, as bricks, which retain the heat from the confined air better than stone; and they should be built with hollow chambers, as advised by Mr. Loudon, for the same purpose. Where painting is needed, white is the best colour. To prevent the bad effects of cold east winds in the spring, causing the sap to descend in standard fruit trees, and destroying the blossom when expanded, by the check it gives to the ascent of the sap that should nourish it, the stems and branches should be bound with straw ropes, and the ground mulched. Various situations should be chosen, to protect tender shrubs and trees,

according to the nature of the plant. For those that spring early, and are apt to be nipped by spring frosts, a north border and cold soil are best to retard their time of starting till the danger from frost is less; for those that suffer from want of the wood being ripened sufficiently, as many American plants which have a warmer summer in their native situation to ripen the wood, as also for those that suffer by autumn frosts before the wood is ripened, a south exposure and warm dry early soil are best: in dry soils there is not so much wood made, which is more easily ripened; and the more sun, the more likelihood that the wood will be ripened before frost sets in. In some late wet autumns, we have had some of the hardiest of our trees killed: transplanted birch, after being some years transplanted; oaks, that were apparently sound, dying down half their length in the ensuing spring; and seedling American oaks dying off in the ensuing summer, after having begun to grow; thus showing that even the hardiest of our trees may be affected, from not being sufficiently ripened in a cold wet autumn. The presence of a stream or river is generally allowed to increase the tendency to slight frosts in spring and autumn. The surface of the water, as it condenses by cold, descends to the bottom, and a warm stratum succeeds to the surface; and so far the tendency is towards heating, rather than cooling the air; but the great evaporation that takes place through the day, and early in the evening, robs the air of so much caloric, that fields situated near shallow rivers, streams, and bogs, have generally been found most liable to frost: near the sea, or near great bodies of deep water, the first-mentioned effect, of a succession of warmer stratums to the surface, prevails, and we have less tendency to freezing. Watering in the morning early, if the frost has not penetrated to the juices of the plant, may, by washing off the cold dew, prevent the frost from penetrating; and covering from the sun may save a plant partially hurt from the excessive change of temperature, if a bright sunny day succeed the frosty night: but no power on earth can recover the plant if the juices have been expanded by freezing till the vessels are burst, which may be known by the change of colour in the leaves by the suffusion of the sap. If some of the most tender leaves only are hurt, on the young growths, the plant may survive; if the wood is generally young and succulent, as in seedlings, dahlias, &c., the whole plant generally perishes, unless where there is an old ripened root or wood to renew vegetation. Some plants, as beech, that throw out or evolve most of their young buds in spring, are apt to perish, even though some years' old, before the latent buds can spring; the oak, ash, &c., that have always spare buds, are not so apt to perish. As to the acclimatising of plants, I am of Mr. Beaton's opinion, that we cannot alter the constitution of a species,

however much by circumstances we may affect individuals for a time.

On the subject of the Colours of Plants, noticed by the professor in this section, it has been said by chemists, in analysing plants, that in the red and deep colours acids are most prevalent, and that in the green and light colours the alkalies abound: and, having been formerly a very assiduous cultivator of tulips, I have frequently tried the effects of the alkaline lime in depriving what are called run or too highly coloured flowers of their excess in colour; and likewise the oxide of iron, an acid, and the natural colouring matter of the soil, in producing colour in those which were too light. We had few tulips too light in the beds; this does not occur so frequently as too dark, and we do not recollect of much success in our experiments this way; but we have seen beds of tulips to come more than ordinarily coloured, technically foul, when composts were used, owing to ignorance, from ditches where oxide of iron was deposited, a very common occurrence, especially in clayey soils; and, though the deposit in the ditch should be otherwise rich, it should never be used where light-coloured flowers are wanted; the effects produced from these deposits, however, would lead us to infer that oxide of iron will produce more colour in flowers that are too light. In our experiments with lime, the trials were more frequent, and with more decided effect. We have had flowers of *Imperatrix florum*, *Bienfaite*, and other flowers, so full of colour as to be nearly selfs, and to which we applied lime in the soil, come much paler even than their usual state of colour, some of them nearly white: this alteration did not take place till the year after applying the lime; thus showing that the next year's flower had been altered in the vessels that were to cover the chromule of the next year, while yet in embryo in the root.

The effects of heat and cold on plants are so minutely entered into in the work before us, the effects of frost so minutely described, both in this section and the one on atmospherical temperature, and so great a range of temperatures from different countries brought forward, that it cannot fail to be highly interesting to all concerned in the cultivation of plants.

On the next sections, of Moisture of the Soil and Watering, also Atmospherical Moisture and Temperature, the causes and effects of want of moisture in the air of houses are fully explained, and to this and the able article in the *Gardener's Magazine* for June, by Mr. Rogers, jun., little could be added. In the open air, some situations, as the vicinity of woods and hills, by their effects in electricity, are more productive of rains than others; some kinds of stones, as trap, clay slate, &c., are more retentive of moisture than quartz, silix, and others; and soils from the debris of these, as clayey from the former, are more retentive of

moisture than sandy soils from the latter ; manures and decomposing substances retain and give out moisture : but to the capillary attraction of the narrow apertures of a well-pulverised soil, as the professor remarks, we should look as the most beneficial source ; if contained in greater quantity, it is prejudicial ; and if the clayey composition of the soil or subsoil, or the inequality of its levels, presents an obstruction to the outlet of the superfluous water, draining must be had recourse to. In the work before us the bad effects of too much water are clearly pointed out, and the periods of the growth when most water is required detailed ; as also the little good to be got by watering in dry weather, owing to the dry and heated state of the atmosphere. On this account, any water we give should be given in the evening, when the soil has time to imbibe the water in the cool of the night ; but, unless the waterings are copious indeed, they are generally evaporated by the next day's sun, and the water diluting the soil into the consistence of soft puddle or paste, it is hardened by the sun of next day into a crust or cake, the bad effects of which have before been noticed in the section Bottom Heat : by degrees, as the operation is repeated, the crust gets thicker, and thus often to small seedlings and other plants more harm than good is done by watering without covering. To prevent these bad effects and lessen the evaporation, a covering should be spread above through the day to shade from the sun, and removed at night at the time of watering. If the seedlings are in small patches, as annual flowers, they should be covered with an inverted flower-pot a little raised from the ground to admit air, or a piece of bast mat or thin cloth is better, to screen the heat and allow as much as possible of the light to pass ; and they should be elevated on sticks to allow the air to circulate freely. When the seedlings are in beds, the surface should be hooped over, and bast mats tied above the bed, not reaching quite to the ground, but so as to screen the heat, allow a little of the light to pass, and the air to circulate freely below ; the mats should be removed, and the bed watered regularly every evening, so as to get the benefit of the dews and night air, and replaced in the morning before the sun gets hot. This is troublesome and expensive, but when the seedlings are valuable will be found to repay both. In the dry summer of 1826, we preserved a bed of seedling black spruce (*Pinus nigra*) by this means, which got no rain from the time they were sown till about 10 or 12 weeks afterwards ; but by this treatment they grew stronger and better than usual, and their value was many times the amount of the expense. When plants cannot be deferred planting during the time of a drought, if small, such as vegetables or herbaceous plants, a good plan is, after watering, to invert a flower-pot over them ; the plants, however, generally suffer so

much, it is better to defer till rain comes. If the plants are large, as evergreen shrubs, &c., the roots should be as little exposed to the drought as possible, matted or tied with moss where necessary, and the moisture as much as possible retained in the ground, by performing the operation expeditiously. As soon as the fibres are regularly spread, and a quantity of earth put on, the ground should be firmly and solidly trodden with the feet all round the roots, and the whole saturated completely all round with water, to the consistence of puddle. When this has had a little time to subside, spread the little dry earth left on the surface above the moisture; this prevents evaporation and crusting of the surface, and, if properly done, the plant will need no water for a considerable time. Shading will, in all cases of transplanting, be found beneficial. Where the plants have been long established, and are beginning to suffer from drought, shading very long is apt to draw them; this may be helped by elevating the screen to give as much air as possible, making it thin so as to allow the passage of some light, and giving as long exposure as possible in the night and morning. But it will sometimes be found, in long-continued droughts, that such as beds of ranunculus coming into flower are apt to be drawn weak, and the flower fail: before they begin to draw much we should be at the trouble of covering the surface of the soil between the rows with green moss; we may then expose to more of the sun with safety, and even water more safely, though the sun should be up at the time of watering; the moss keeps cool, absorbs the water and gives it out as required. When large plants, some time established, are beginning to fail, and require to be watered, it will be found greatly to economise water and have more effect, to pare off the dry soil down to near the fibres of the root, drench well with water to saturation, and then cover up with the dry earth; one such efficient watering will be as good as ten surface waterings: if the leaves need a little sprinkling of water, do it in the evening, and shade, if necessary, from the sun. The excellent rules given by the professor in watering house plants, to give most water when plants are commencing their growth, and to discontinue as they ripen, &c., need not be repeated here. As to the quantities of water required for individual plants, a general rule will be found, that the quantity should be greatest according to the size and quantity of the fibres; but to this there are exceptions: the thorn is a plant with but few fibres, and those hard and wiry; but, in long-continued dry seasons, it always sets up in the growth and gets mildewed in the foliage; in wet seasons, unless when very cold, as the present, it will be found to grow twice as much as in dry seasons.

Mildew is often produced in frames by damp and want of air, and I have often heard the mildew in peas ascribed to the same

cause; but from the experiments of Mr. Knight, quoted here by Dr. Lindley, it appears that, like as with thorns, the want of water is often the principal cause, perhaps by occasioning a stagnation in growth, and thus furnishing a nidus for the seeds of the fungus. Some disapprove of manure to peas, but others that dung heavily have good crops; in very wet cold seasons, as the present, manures may retain too much water, but generally should be useful in preventing stagnation, which seems to be the cause of the fungus settling on the leaves. I have been often puzzled with the appearance of mildew among seedling larch. It is frequently the case where seedling larch are grown to any extent, especially after being grown some years on the same spot, though in rotation only, to have the seedlings go off in July and August, in round patches that increase in size, but generally preserve the circular form like the fairy rings of fungus. I have heard this ascribed to improper manure, but have seen it take place with all sorts of manures. I never could perceive, after minutely searching the ground, any insects in quantities that were likely to cause the mischief observed; but have found the outside of the circle, at the surface of the ground, covered with a web of minute hairs similar to the mildew in frames; and as the plants die first at the surface when the tops and roots are quite fresh, I think the mildew or fungus must be the cause of their death, but have been puzzled what is the cause of the fungus. It is quite different from that on the thorns and peas, and similar to the one in frames, which is generally allowed to be caused by damp and want of air; this cannot be the case with the seedling larch, as we have observed it in airy places, and all kinds of weather and soil: perhaps it is not the same, though similar; and the seed of the fungus, deposited and accumulated in old soils, may spread in rings as other fungus do, and might be best stopped by spreading lime or salt, if necessary, round the ring to prevent its increase.* The rules given by the professor, at the end of the section on Atmospheric Moisture, should be carefully committed to memory.

The next subject, of Ventilation, has been largely and ably handled of late in the Magazine. Dr. Lindley shows the necessity of ventilation to respiration, in carrying off noxious vapours, and producing dryness and cold; he also quotes Mr. Knight for its necessity in giving motion to plants, and increasing the circu-

* We have had a fungus amongst our willows for some years, of a bright orange colour, which is a clear proof of the belief that the smut in wheat may be got from the soil as well as the seed. The first year of its appearance, we observed it on the leaf only; now it is frequently to be found in the midrib of the leaf, and on the stem; and on examining with the microscope, the fungus may be traced a good way below the bark, which is heaved up from the inside outwards,—a clear proof that the fungus exists in the sap of the plant, and must have been absorbed by the root.

lation, and thus the health. Alpines, heaths, and most New Holland plants will not do well without this motion of the air. He also notices the necessity of keeping the house close at the time of setting vines; the injuries done by too much ventilation; the opinions of Mr. Knight on that subject; and the success of Mr. Ward in growing plants in confined glass cases, without any ventilation. None of the plant cases in our quarter, nor any we have heard of about Edinburgh, (though *Orchideæ*, and other plants naturally growing in close confined places, will do well in them,) seem to warrant the opinion, that plants in general will thrive as well without any ventilation as with a moderate portion. Some of our best grape-growers allow that a good deal of air is necessary, when the grapes begin to swell, to strengthen the footstalk and prevent shriveling; others are no doubt of opinion that shriveling proceeds from a failing of vigour at the root, or too much divesting of the lateral foliage above the bunches; but there may be good reasons given for both opinions, and perhaps both are causes. The bad effects of air in drying may be greatly helped by the shallow zinc pans of Mr. Rogers, jun., where hot-water pipes are used; or by getting the tile covers of the flue cast with hollow panels, to hold water for evaporation; where these are not used, copious and frequent sprinkling of water should be resorted to. In confined places, the oxygen and hydrogen may be supplied by the water, and the carbon by the decomposing substances in the soil; but a renewal of the air may be needed for a supply of nitrogen; and as the rays of the sun may be separated into light, heat, colour, and chemical rays, as all these, and the electrical state of the atmosphere, may be affected in ways we cannot yet account for, by screens interposed, and may affect vegetation and maturation more than we are yet aware of, we should be cautious in giving or withholding air, and guard ourselves well by experience. Light is generally believed to be the most necessary, in maturation of the fruit; and the most transparent screens, and best reflecting walls, as white or polished surfaces, should be used for this purpose, till farther experience may lead us to modify our opinions. Should electricity be found beneficial, glass and wood will be bad materials, being bad conductors; metal and oiled paper or talc might be better.

On the next sections, of the Germination and Maturation of Seeds, Dr. Lindley quotes Berzelius as to the proportions of carbon in gum and starch; and makes the gum to have the larger proportion of carbon and the less of water. M. Schultze, in the Prize Essay given in to the Academy of Sciences, on the circulation of the latex, or blood of the plant, considers gum as the first result of the fixation of carbon with hydrogen and oxygen; and that sugar, starch, and fibrine are farther degrees of fixation, containing more carbon.

The author of the treatise *Botany in the Library of Useful Knowledge*, and Mr. Ellis in his *Enquiries into Vegetable Physiology*, seem to be of the same opinion. When we examine seeds in their newly formed state, as oats and wheat in the ear, we find the matter beginning to be deposited as the future food of the embryo of a milky mucilaginous consistency called gum; as it continues to ripen, more carbon is deposited, the food gets more solid, and ultimately assumes the condition of flour or starch; which, if the weather has been sunny, gets nearly as hard as wood. This is a wise provision of nature for the preservation of the seed: in its recent or mucilaginous state, much less heat and moisture would decompose it, and these unripe seeds would not keep well; but before the young embryo can receive nourishment in the spring, from the food deposited for that purpose, it must be again decomposed and made soluble. We thus see how well-ripened seeds, which have their food highly fixed, by the deposition of carbon, into the form of starch or flour, are so much more easily preserved; and how unripe seeds, provided only, as Dr. Lindley says, their embryo be perfected, will germinate more quickly than ripe seeds; the starch of the ripe seed must be again reduced to mucilage, before it can become soluble food. M. Raspail, in examining the starch of plants, found the ultimate particles to consist of a substance similar to gum or sugar, but polarising light to the right, whereas the other did it to the left; and he therefore called it dextrine: this dextrine is soluble in water, but each of the particles he found to be surrounded with a hard shell or skin which is very insoluble, and requires a high heat to burst it, Mr. Ellis says 160° to 180° ; the author of *Botany (Library of Useful Knowledge)* says nearly a boiling heat; and that, to produce the heat necessary, we must, after all other sources, add the vital heat, when the embryo is stimulated into life. M. DeCandolle suggests that tannin and alkaline matters may help to rupture the shell of the starch. Mr. Charles Maltuen found that seeds in germinating threw off acids, and retained alkalies; and that they germinated at the negative, or alkaline, pole of the battery much sooner than at the positive, or acid, pole; and afterwards, by enclosing seeds in glass phials filled with solutions of different kinds of acids and alkalies, he found that the seeds germinated in the alkalies in a third part of the time that they did in the acids. M. Payen (*Journal de Chimie Médicale*, Avril, 1834) tried seeds of wheat, rye, barley, oats, and maize, in water, and in water mixed with different proportions of soda, lime, and tannin; and he found, from experiment, that the seed in growing gave off acids; that those in the alkaline mixtures grew quickest; and, as the acid given off increased, the seeds in the alkaline mixtures grew still more perceptibly quicker; and, when the alkali neutralised by the acid given off was replaced,

it still further increased the growth ; also that in tannin they would not grow at all. Mr. R. Hunt (quoted from the *Philosophical Magazine*, in the *Gardener's Magazine* for June) exposed cress seeds to blue, green, red, and yellow rays of light ; the red and yellow rays, which are the colours said to be produced by bodies abounding in acids, destroyed the seeds altogether ; while in the blue and green rays, in which alkalies are allowed to predominate, the seeds grew well, and best in the blue. All these experiments seem to point to alkalies as beneficial in germination. Oxygen is necessary to reduce the starch, by extracting its carbon in the form of carbonic acid. Dr. Lindley seems to think this oxygen is principally obtained from the decomposition of the water. Mr. Ellis, and the author of *Botany (Library of Useful Knowledge)*, seem to think it is principally derived from the air, perhaps it may be derived from both sources ; the oxygen of the air being only mechanically, not chemically, combined with the nitrogen, should be easily separated. That air is necessary in germination seems corroborated by the fact, that seeds will preserve for an almost indefinite period of time, if buried deep in the earth, beyond the action of the air, though subject to moisture and heat ; like toads enclosed in stone, if the seclusion be complete, the seed may live for centuries. Light is prejudicial to germination, as it causes the emission of oxygen, and helps to keep the carbon fixed ; and starch, having more carbon than mucilage, must part with it before the food becomes soluble. The great endeavour, in the germination of seeds, should be to get as much of the food as possible made soluble ; the strength of the growth of the young plant depends upon the quantity made available by solution, and not on the absolute quantity present. In seeds containing a great quantity of highly concentrated food, germination proceeds very slowly. We have had seeds of *Gleditschia triacanthos* to lie in the ground for years before germinating ; and these and other acacias are said by Cobbett and others to be the better of being exposed to the steam of boiling water for some time, to help in the solution of their food ; but this should be done with caution. Onions, spinage, and some other seeds, may be made to sprout their radicle in the course of twenty or thirty minutes, if exposed to the steam of boiling water, but this over-excitement weakens them, and is not beneficial, unless to test the quality of a sample. The moist heat of a dung hot-bed is safest, and few seeds will be found to resist this, if sound and fresh, and come to their ordinary time of springing, which differs much in seeds, and for which there is no general rule. Dry farinaceous berries, with hard stony kernels, lie longest, as the holly, which will sometimes lie three or four years in the ground, and thorns two or three years ; the cherry, which has a hard kernel and pulpy fruit, comes generally the next or first year, if sown in autumn ;

so do laurels, *Arbutus*, mountain ash, &c. Seeds with shells generally spring the first year, if under favourable circumstances, but some, as hazel nuts, &c., will lie over, if the spring is dry, to next year. Naked seeds generally come the first year; some, as ash, tulip tree, &c., lie two years; elms, and a great many flower seeds, grow best when sown the year they ripen, as they come off the plant. The period of germinating in all seeds may, however, be hastened by collecting the seeds before they are fully ripe, and all their carbon deposited, and sowing immediately to prevent their drying; also by laying the berries, &c., in heaps, to facilitate the decomposition of their pulp; and the heat, which is extricated in this process, helps to render the food soluble. Thorns will come the first year, and hollies the second, if carefully kept in this way: but they must be watched; laid in thick heaps; kept in a cellar from air, and weather, and light; and turned frequently, to prevent their spoiling from too much heat.

It is necessary that seeds be covered in the earth to exclude light, and to secure moisture and heat; but the degree of covering should vary with the strength of the seed. In seeds that push strongly, the exclusion of light, and the securing of moisture and heat, are best effected by a pretty deep covering, which also strengthens the roots; if too deep, however, the stem gets etiolated and weak before coming through. As before said (in the section *Bottom Heat*), if the soil is well broken into small particles in dry weather, the heat and moisture are retained better and the light more perfectly excluded; for large seeds, however, it should not be raked so very fine on the surface, as it is more apt to skin over with wetness, and exclude heat. The depth of covering should be varied with the nature of the soil, whether adhesive and damp or loose and dry; also the expectation we may form of wet or dry weather, from the nature of the climate, period of the year, and state of the weather. From one eighth of an inch to 2 in. should be sufficient for most seeds; though some, as the birch, &c., are so weak as hardly to stand any covering; and others, as the walnut, &c., in some soils may be the better of more than 2 in. Small weak seeds are difficult to manage; birch and some others can hardly be covered too lightly, if covered at all; and the more dry powdery dust in the cover, the less will be required: they cannot rise through a deep cover, and they must have all the requisites of heat, moisture, air, and exclusion from light, if possible, in a superior degree. If the ground is left rough or skinned on the surface by being done in wet weather, this object is completely defeated: the ground should be worked in dry weather, broken very small with the spade, and raked with a succession of smaller rakes, well twisted through the soil till the surface would pass through a plasterer's narrow sieve. As noticed before (see *Bottom Heat*),

these operations are greatly promoted by having the soil dug rough in frosty weather in February; and the rotten manure, spread on the surface, is of more benefit to the seedlings by being nearer the roots, as this rough dug ground requires only to be pointed shallow with the spade, and does not require digging. If the ground is thus worked in dry weather, and the weather keeps dry a day or two afterwards, the small particles get thoroughly dried, and, unless the rains are more heavy and long continued than usual, the soil will keep open for the most of the season, heat and moisture will be retained, and the air will penetrate freely; and the difference between this and ground left coarse or worked wet will be so great, that by thrusting the fingers into the former in a tolerably warm day it will feel like a hot-bed, while the other is cold; the small particles have narrower apertures, and consequently retain more moisture by capillary attraction, light is better excluded and air admitted to give off its oxygen and supply nitrogen; and for seeds difficult to germinate and keep growing, the chances of their doing well are thus manifold increased. If the weather is at all favourable after this (gentle showers and warm weather are the great requisites), and if this state of weather succeeds to the above operation, a crop will seldom fail if the seed is good. To endeavour to insure heat, very small seeds should not be sown till the spring is so far advanced that warm weather may be expected; and if the weather gets very dry, and the seeds are valuable, they should be shaded through the day, and watered in the evening, as advised in the section Watering. It is not every soil that will suit these operations: for very small seeds, the very lightest quality of soil should be chosen, and even the best of soils should be dug up, and left as rough as possible, in dry frosty weather in February, in order that the expansion of the water by freezing may break up its texture, and make it easier afterwards to separate the soil into small particles. For onion and other larger seeds of the small kinds which push more strongly, the bed will do, though a little rougher; it is not so apt to skin, and the seeds will come through a deeper covering; but the ground should in all cases, if possible, be worked dry, and the spadeful well broken to the bottom of the spading: a great many more small apertures are thus made, and the advantage to the growth of plants in soils thus kept open, above those sodden and soured by wet, will be found very great. In a well-prepared bed, for small seeds, half the quantity of seeds will suffice, as will be obvious to any who have had the experience of having one end of the beds of a more stiff sodden texture; though three times the quantity of seed should be thrown on this, the crop will not be so good. A fresh newly worked surface is indispensable for seeds; as before observed (on

the section Bottom Heat), the surface, so much pulverised, has a tendency, by the rains and action of the weather, to get closed again; and the seeds do not rise so freely as when the soil is open. So much is this the case, that I have frequently seen, in beds of seedling trees that had failed and stood for two or three months, if the surface merely were raked when new seeds were sown, the plants came up quite yellow and sickly in the cotyledons, and there was a necessity to point it up again with the spade, and bring up a fresh surface, before we could secure a healthy braird. From the same cause, when seeds lie long in the ground before germinating, they often come weakly; and, to obviate this, the best method is to bring the seeds as nearly to sprouting as possible before sowing, when they come through quickly and strong. Many small seeds, which will not bear deep covering, and for which we cannot always get a sufficiently long period of cloudy weather, are also with more certainty managed in this way, by bringing them nearly to germination before sowing. For this purpose, they are generally spread on a damp floor in a dark corner, 1 or 2 feet thick, if in quantities, or on separate floors or saucers if the quantities are small, and thoroughly wetted all over from the rose of a watering pan; the seed repeatedly turned with a rake, or the hands if necessary, till all the seeds are damped, and then left for a few days, when it should be again turned to prevent moulding and decomposing, and, if getting dry, damped again; and this should be continued every three or four days till the time of sowing. The seeds are thus kept regularly damp, and excluded from light, from which they should be covered if the place is not dark; and, as the farina of the seeds begins to decompose, oxygen is extracted, and the heat given off is thus collected in the heap. For all weak, dry, farinaceous seeds that take a long time in vegetating, as birch, alder, larch, spruce, carrot, &c., this method is very beneficial; for pines, turnips, and other oily seeds, that do not require so much water to germinate them, it is not so necessary, and there is more danger of their spoiling from want of attention in turning. A little quicklime in the state of powder, mixed among the seeds when damping, is very beneficial in promoting germination; it furnishes an alkaline substance which we have seen is beneficial; it has also a great affinity for carbon, from having parted with its carbonic acid in the act of burning, and carbon must be taken from the food to render it soluble; oxygen is also extracted from the air or water to form the carbon into carbonic acid, and the extrication of oxygen produces heat. We had an opportunity of testing its good effects some years ago (as narrated before in the *Gardener's Magazine*), on some old spruce fir seed which had been three years out of the cones. The year before, when two years out of the cone, the seed, when damped

in the way before narrated, did not swell as new seed does, and had a mouldy smell; when sown, it came up thin and weakly; the cotyledons, yellow and sickly, could not free the soil, and the greater part died; but in the third year, on the lime in the state of powder being dusted all over the seeds at the time of damping, and left for a few days, the effect was soon visible, in the seed beginning to swell round and plump, and having the sweet sugary smell of fresh seed when it is germinating: this continued for twelve or fourteen days, at which time it was sown, and soon started through the ground, with its cotyledons upright, of a healthy green colour, and as strong as the first year's seed. I have frequently applied it since to other seeds with good effect; and any person who will try it on seeds of the farinaceous description we have mentioned, will find them to vegetate more quickly and strongly than those sown in the usual way; but I have had no seeds to operate upon, from which such decided effects could be expected. Every nurseryman who is in the habit of sowing spruce seedlings knows that spruce seed will not keep three years out of the cone and grow well. The exposure to the air has a powerful effect in injuring seeds. A little onion seed, left in a drawer and thinly spread, will not grow next season, while the same seed kept in quantities, and tied up in double bags, will grow well: we have seen a few pounds, tied up in paper and laid separate, lose as much as $1\frac{1}{2}$ oz. per pound in a month's time. Carrot seed loses a good deal also; peas well ripened not so much. The above spruce fir seed had all the advantage of being enclosed in bags from the first, but this exclusion is only partial, not complete, and the second year its food had been very much dried up and deteriorated; the third year it was still worse, and had the bad effects continued so long, that the vitality of the embryo had been encroached upon, no chemical application could have been effectual. It is only with seeds in a condition similar to the above spruce fir seed, that we can hope for decisive effect, to badly ripened seeds lime could be of no use; and when the embryo has lost its vitality, though it may assist in decomposing the food, it cannot revive; but, as I said before, if carefully done, it will be found beneficial to all seeds, in causing the more perfect decomposition of their food, and making them shoot into growth more strongly: it should be carefully observed to keep the seeds always damp; if allowed to get long dry, the caustic effects of the lime will be hurtful. I have frequently tried the oxalic acid, recommended by M. Otto, without producing any perceptible effect, but neglected to do so with the spruce seed alluded to. I am of opinion, however, as stated in the article Botany (*Library of Useful Knowledge*), that the air and water should be capable of producing all the oxygen wanted. For seeds raised in hot-beds,

the same rules should be observed. The compost used should be dry, and broken small with the spade. For large seeds, the surface may be left more rough, to keep it open; for small seeds, it should be sifted very fine for the surface; and the smallest seeds, as rhododendrons, should have hardly any covering at all. The glass should be covered with a mat, to screen the light when the sun is strong, as it tends to stop germination by keeping the carbon fixed, evaporates the moisture, and skins the surface of the soil; but, as mats prevent the heat from entering, which is much wanted, they should be thrown off whenever the weather is dull and cloudy, and should be taken off soon in the evening, and delayed putting on as long as possible in the morning. A better screen for the light would be strong paper oiled: this substance excludes and refracts the rays of light more than glass; and, as the refraction of the rays by our atmosphere is the cause of heat, it will be found, that in frames covered with oil-paper, the heat is much greater than in those covered with glass; and, if made sufficiently strong to keep out rain and wind and wear well, a frame with the sashes constructed of oil-paper in place of glass would be the best for germinating seeds, though, from the want of light afterwards, and from that light being of a rather too yellow colour, they would not grow so well if continued under it. Covering the pots with saucers and pieces of glass increases the heat by confining the air, and retains the moisture by preventing evaporation; a cover of oil-paper would be better than either of these, and there would be less need for shading if all the pots had these covers, and the heat would thus be greatly increased; the covers must be taken off as soon as the young plant appears, or rather just before it appears, or it will come etiolated and weak from too much stimulus. The quantity of water given to seeds must be regulated by the nature of the seeds. Oily seeds, as the genus *Pinus*, &c., require least water, and are the most easily hurt by excess; resinous and waxy seeds, as the genera *Picea*, *Magnòlia*, &c., do not require much; farinaceous seeds, as the genera *Abies*, *Làrix*, *Acàcia*, &c., require most. Much depends on the heat of the bed, the shading, the open or close texture of the compost, the drainage of the pots, and the nature of the pots themselves. Hard vitrified pots are not at all suitable for tender seeds. The surface should be allowed to dry now and then to prevent skinning. When the heat of the bed is such as to require a good deal of water there is more chance of success, by the stimulus given to vitality, and the expansion and decomposition of the water.

In the sections Seed-saving and Packing of Seeds, there is much concerning the sterility, fertility, and parentage of seeds that should be carefully studied. Moisture is there said to be prejudicial at the time the plant is in flower; heavy rains wash off

the pollen, and the particles of farina will not divide so freely, nor will they will burst so readily on the top of the stigma, in cold wet weather. Most practical gardeners, however, are of opinion, that fruit sets best in a moist heat: perhaps the moist heat is favourable to the developement of the glutinous secretion on the top of the stigma. In preserving seeds, keeping them cool and dry is certainly the principal means to be used; exposure to either heat or moisture in excess must injure. The great danger to seeds crossing the equator is heat; and as substances that are slow in absorbing heat are equally slow in radiating, and consequently retain heat, it may be difficult to get a proper medium to exclude this danger. Charcoal has been used, some say, because it is a bad conductor. Professor Thomson says, charcoal prepared in the usual way, at a low heat, is a good conductor; and only when prepared at a red heat, a bad conductor: the charcoal may, however, help to dry up the moisture. Grey paper packets, and coarse canvass bags with free ventilation, and the seeds dry, as observed by the professor, form perhaps the best way of packing in seeds crossing the equator. Berries are best packed among very dry sand, to dry up the moisture as the pulp decays. Where excess of heat and moisture can be guarded against, exclusion from air is the greatest requisite: it is difficult to exclude it perfectly, but our experience would lead us to infer that the more this is done, as when kept in heaps, and enclosed in thick and double bags, the better does the seed preserve its vitality. We have before taken notice of the great loss of weight sometimes occurring in onion and other waxy seeds: in clover seeds, the colour is the practical test of its quality; and in seeds of these kinds preserved from air as much as possible, the clover has a better colour, the onions, &c., are heavier, and grow better. When excluded completely from air, by being very deeply buried, seeds will live for indefinite periods; as has been frequently experienced from the plants springing out of earth dug from deep mines. Some oily seeds, as turnip, &c., keep long. The Scotch fir, an oily seed, will keep longer than spruce or larch, farinaceous seeds. The coffee, a farinaceous seed, loses its vitality very soon. The lint seed, again, an oily seed, will not keep so long as some farinaceous seeds. The oak has a hard shell, and farinaceous cotyledons, and yet will not keep so long as some seeds that are much softer. Oily seeds are most easily hurt by excess of moisture, and farinaceous seeds by heat; but it is impossible to give a general rule: the vital principle is most likely strongest in those that keep longest. On the maturation of the fruit, the remarks on the size of the fruit being at the expense of the seed and high cultivation, consequently against the vigour of the

progeny, and the other subjects noticed in these sections, are full of information.

In the section Growth by the Root, some have contended that the young spongioles of the root were incapable of conducting sap, and that it was only after their organisation was completed that they were of any use; but the plain doctrine laid down by the professor, that the young spongioles, so soon as formed, commence their functions, tallies best with experience. The fact noticed, that the young spongioles are found to be rich in nitrogen, shows the benefit of keeping the soil open to admit air freely, the great source of nitrogen. The young spongioles of the root being the great source of nourishment to plants, every means should be used to increase them. In soil made free by manure, the interstices left encourage the fibres to run among the soft manure; and turf in the act of decomposing is still better. The old thatch and turf from a house cause plants to root and grow luxuriantly; but the greatest promoter of roots is well-rotted leaf mould: if a handful is put round the roots of a pot plant, that is wished to be encouraged to root, it soon becomes like a wig. On the excrement by the roots, I formerly sent you a paper on a substance apparently excreted by the roots of spruce and Scotch fir. It sometimes, as I noticed there, appears to run in threads like a fungus. There is no notice of any fungus on the roots of any of these trees in the *Encyclopædia of Plants*. There is one noticed as occurring on the roots of oaks, and a white substance, something partly resembling these in its appearance, is sometimes found on the oak; but it only occurs on some plants, not all, and in small quantities; whereas, in the spruce and Scotch fir, it is on every plant, even on the very youngest seedlings when newly sprung, clinging to the minute spongioles, having every appearance of having issued from the pores of the skin: perhaps there may be both an excrement, and a parasitical fungus growing on the excrement. On the propagation by the root, noticed in the same section, those roots which abound in milky juices, as the genera *Rhús*, *Euphórbia*, *Nuttállia*, *Papáver*, &c., will produce buds most readily; the harder, drier roots, as *Cydônia*, roses, plums, &c., with more difficulty; while small hard wiry roots cannot be made to do so at all. In general, it will be found that plants which are most difficult to propagate by layers and cuttings propagate best in this way. The rest of this section, and that on growth by the stem, is very interesting, plain, and easy to be understood. The reader is not confused with a detail of beaded and spiral vessels, tracheæ, &c.: the plain doctrine of the woody, fibrous, or perpendicular tissue, and the spongy, cellular, or horizontal tissue, with the pressure of the latter into medullary rays, thus opening a communication through

the whole system, may be easily comprehended by any. A slice of any soft wood, as ash, will show the medullary rays; and a young transparent branch of a soft herbaceous plant, as the dahlia, or a young seedling pine, will show the fibres to follow from the cotyledons and leaves in an undeviating manner. Whether every leaf sends down its fibres as far as the root would be difficult to trace, as they generally penetrate under those below them; but that roots proceed from fibres is easily seen on examining the cuttings of dahlias, of sorts which are difficult to root. Before the roots issue, the white ends of the fibres will appear, as if ready to protrude, and only retarded by the too thick skin or epidermis, or the want of an accumulation of nourishing cellular matter at the bottom; the cutting having been too old, or too much hardened when taken off, either from its age, or the nature of the sort inclining more early to harden the epidermis. The theory of Dr. Darwin, however, of the fibres forming roots, was too far carried, when it was asserted the graft would change the nature of the stock, which practice points out as incorrect. The shoot from the stock of the grafted plant is always the same as the stock, unless by accident; and the stock does not swell as the root does. The experiment mentioned by Mr. Niven is uncommon. It may be possible that a tree might live, for a time, with its bark and alburnum, to a considerable depth, taken off for a considerable portion of the stem all round, as said; but that it would continue to live, and be healthy, is hardly credible. It is the common practice in America to kill trees in this way, by what they call girdling, to save the trouble of felling.

The section on the Action of Leaves is highly interesting and instructive: their nature and uses are clearly and forcibly illustrated. The recovering of weak plants, and plants infested with red spider, is greatly facilitated by keeping the back of the leaf moist. Polyanthus, and other plants in pots, which are apt to suffer in this way, are greatly benefited by reversing the plant, and dipping the leaves in clear cold water.

In the section Action of Flowers, there is much brought forward that ought to be carefully studied. The production of flowers proceeds from a highly concentrated state of the sap: whatever may be the quantity of sap produced, it must be perfectly elaborated, before the petals, stamens, and pistils can be formed, which are a higher state of existence than leaves. However great may be the quantity of sap, if we have heat and light, and action of the leaves to correspond, the flower and fruit, those higher states of existence, will be formed; and if the tree is growing vigorously, whether from failure of the year's fruit, or from being naturally vigorous; and if the summer, but especially the autumn, is warm and dry, to ripen the wood and concen-

trate the sap, we may expect abundance of blossom the ensuing year. But if the plant is excessively vigorous, unless the elaborating agents are likewise in excess, flowers and fruit cannot be expected; the tree will grow to wood in the ensuing season, from few flower-buds being formed, the sap not being elaborated properly: what would have been a benefit, is thus converted into a drawback; and in order to insure the elaboration of the sap, since we cannot augment the power of the elaborating agents, we must decrease the quantity of sap to be elaborated, by giving the tree extent, making the borders poorer, curtailing large arms from the root, ringing and depressing the branches; and the smaller quantity of sap furnished is thus more easily and perfectly elaborated, and the more perfect state of existence produced. The size and quality of the fruit are, however, nourished by the vigour of the tree; and when blossom is once produced, the most vigorous tree will undoubtedly produce the best fruit. The quantity of flavour thus depends on the manner in which the sap is elaborated; the quality of the fruit, on the quantity of sap: the more sap that can be elaborated, the more blossom there will be. Old trees that have attained their height are not so vigorous in the young shoots; the shoots are shorter, and the bark thicker, and they ripen sooner and more perfectly, and are more productive of fruit. A graft of a young seedling, introduced among these branches, will thus flower and show fruit much sooner than if growing on its own plant, not come to maturity. In preparing bulbous roots, also, for flowering the ensuing season, as hyacinths, amaryllis, &c., when we cannot ripen a large root sufficiently, we had better be content with a small one well ripened; a firm, hard, well-ripened root is always the best, though the size should be smaller. In the same way, when we cannot flower plants, as *Oxalis crenata*, *Tropæolum tuberosum*, &c., which have only one season to grow from the root, and on which we cannot wait for years to exhaust by extension; if we cannot increase the heat and light in the requisite degree, we must impoverish the soil, and water sparingly: the principle is the same throughout, and of universal application, where we cannot increase the power, we must decrease the quantity. We see also hence the origin of double flowers. When flowers come double, it is generally by changing the higher state of existence of stamens and pistils into the lower state of petals; and the more the plant is checked or stunted by poor soil or want of water, the more likely we are, by giving luxuriant food and treatment afterwards, to bring back the stamens and pistils to petals, and produce double flowers. The greater the check, the more will be the effect of subsequent luxuriance, by shifting into rich soil, watering well, giving heat, and doing all in our power to induce great vigour and a flow of crude sap;

the flower is not only produced larger, but the crude sap has a tendency to lower the state of existence, and the stamens and pistils being higher in the scale of existence, are reduced to the more inferior condition of petals. Sometimes the scale of existence is so far reduced, that what had been originally the nucleus of a branch, but elevated by elaboration acting on the vital energy into the state of petals, stamens, and pistils, is not only reduced to petals and become double, but will shoot again into a branch, as we have had instances with the Duc d'Orleans, Attelaine de Bourbon, Brown's Superbe, and other roses this season. In the work before us, the instances of the pear producing a branch from the centre of the flower; the double cherry, a leaf from the pistil in the centre of the blossom; and the changing of the petals into leaves in the rose tulip, &c., are all illustrative and confirmatory of what has been said. The instance mentioned of the double Barbadoes lily bearing seeds on the petals is, perhaps, the greatest aberration that has ever occurred; it is more common to have bulbs formed. The double *Lýchnis diúrna* has the stamens changed into red petals, and the pistil into green leaves, and the quantity of each greatly increased. In the rhododendron, the flowers are produced from the terminal bud of the shoot; if the summer and autumn have been warm, the bud swells larger, and we have a branch of flowers instead of a branch of leaves the ensuing spring; but it is always difficult to say, till the bud is evolved, whether we shall have leaves or flowers. In raising double or full flowers from seed, therefore, we should carefully guide our attempts by experience; in procuring the seed, we must get it from the most double flowers we can, as the progeny always bears more or less resemblance to the parent. In the dahlia, the flower is not, strictly speaking, full; it belongs to the compound class, in which a great number of florets are arranged on one common receptacle; in single dahlias, and other flowers of this class, the ray or outer row of florets has the petals fully evolved and coloured; in the florets of the centre or disk, the petal is only in the state of a small tube, inside of which the stamens are situated. Rich cultivation forces these tubes to assume the state of coloured petals; sometimes tubular, as in the quilled dahlias; and sometimes flosculose or flattened, as in others: sometimes the stamens are changed into petals; sometimes they are abortive; but generally, both these and the pistillum are unchanged, and hence there is little difficulty in getting seed from dahlias. Though the way in which dahlias come to be full is thus different from roses, &c., yet luxuriance of growth is here also the apparent cause, the most double flower is always got from the most vigorous plant. In cold summers we have seen the Glory of Plymouth get perfectly full to the centre, by introducing a branch into the inside of a vinery,

while all the other flowers on the plant outside were deficient. Plants that are full of full double flowers at one time, when the plant is vigorous, will change and come more single when checked by bad weather, or when the plant begins to ripen and get woody. In the cultivation of dahlias also, as checking at one time causes luxuriance afterwards to have more effect, the roots intended to be flowered next year should be grown on poor land. The buds will also be more perfectly formed in well-ripened roots; the crown of the root will always be more perfect in a small well-ripened, than in a large soft root. It is a mistake to suppose that the buds left on the cutting have any effect on the root; these buds are always elongated into the stem, and the root must form new buds for itself, which it will not do unless ripened. To return to the raising of seedling double flowers. The roses, pinks, carnations, and ranunculus change the stamens only into petals, and sometimes these are only partially so in very full flowers, and seed is comparatively easy to be obtained from them; we should, as before observed, select from the fullest and best flowers. In the anemone the pistils are changed into petals, the stamens unchanged; seed of these can therefore only be obtained from flowers not perfectly full, or by impregnating flowers nearly single, with a tendency only to fulness, with the anthers of full flowers. In stocks and wall-flowers, both stamens and pistil are changed into petals: seed cannot, therefore, be had from full flowers in these sorts; and the only resource we have, is to save seed from those in which a tendency to fulness has commenced, by having a petal or two more than usual. In growing stocks from seed, they will be more likely to be double, if the plants are checked first by a deficiency of nourishment, whether of water or manure, and afterwards excited to luxuriance by a plentiful supply; and the greater the change, the greater the likelihood of success. Old seed, or seed dried, as in melons, gives a check; we have had instances of old neglected seed, which had been reckoned very inferior when the seeds were fresh and new, come almost every plant double, when a little had been left over and sown when old. The seed for raising double flowers of any sort can hardly be too old, if it will grow at all; and the weak plants, first stunted, and then luxuriated, will be found most successful: the seed should be sown on heat, and the weak plants most cared for. After flowers have once been produced double or full, the habit of coming double will be retained, if kept so by rich cultivation. When any variety has begun to sport, the plants should be raised off those individuals which have not yet sported, as the sporting habit might become fixed; and this should be carefully guarded against, by propagating from those roots that show the fullest flowers. The double China asters, matricaria, feverfew,

daisies, &c., come double in the same way as dahlias ; one variety of feverfew has the inner florets to come tubular, another flosculose. Some composite flowers, as stenactis, erigeron, &c., come partially double ; some, as *Antennaria margaritacea*, have a many-rowed coloured calyx that looks like double. The double antirrhinum is similar to the stock. The thorn, campanula, helianthemum, and most other double flowers, are similar to the rose.

In Propagation by Eyes, some gardeners and florists are in the habit of striking their pink cuttings, or pipings as they are called, by reducing the cutting to the topmost joint, and cutting away all the leaves close above the central bud ; they are afterwards planted in sand, on the top of a rich compost, and covered with a hand-glass. Any similar plant may be struck in the same way ; it is like striking vines by the eyes, and is most apt to succeed in sunny weather, as it depends on excitement ; and though it has not leaves to nourish it, as a large cutting has, yet it strikes root sooner, and in dry sunny weather is not so apt to fail as cuttings, which suit dull cloudy weather best.

On Propagation by Leaves, there is much that is curious, though little to be depended on in practice ; that by scales of the bulb succeeds best with round thick fleshy scales, such as the bulbs of *Lilium lancifolium* ; those that are thinner and drier do not succeed so well. Care must be taken, in the act of separating the scale, to preserve as much as possible of the collet or nucleus at the junction with the bulb ; the scales are similar to leaves, and these to branches ; and in taking off cuttings, when the small shoots can be parted from the stem, with the base or collar uninjured, they always succeed best. The scales are apt to be hurt by moisture, if in excess ; they should be surrounded with sand, and the compost light and free, and the pots well drained ; they should be stimulated by bottom heat, in a half-spent hot-bed, the lights of the frame kept close, unless the weather is very damp, when less water and a little more air will be required.

In Propagation by Cuttings, the treatment depends greatly on the manner in which they are formed, and the state of the weather : if it be dull and cloudy, they will succeed best with their leaves on, and will require more air ; if dry and sunny, they must be kept shut up from the air, and more divested of leaves : a cutting with few leaves, and these cut, is similar to an eye, and requires excitement or stimulus, that with leaves will perish if much excited. As the state of the weather is uncertain, bell-glasses are useful in preventing too much evaporation ; if the frame or hand-glass can be kept very close, there is less need for them. A great deal of the success of cuttings depends on their being well pressed by the medium in which they are inserted ; they can be best squeezed to the sides of the pot, and are found to succeed

best when pressed against it; clear silver sand being the medium which consolidates most readily after watering, and presses most closely to the sides and ends of the cutting, allowing the water to pass freely, is therefore the best. When the weather is cool and damp, there is not much need for shading; light is beneficial, if the sun is not hot. The cuttings suffer most from evaporation by heat, when newly made, and must be shaded if the sun is strong; but, if kept close, the evaporation is not so much, and there is less need: the more heat they can stand, without risk of perishing, the sooner will they root; and when cuttings have been hardened by standing for some time, and appear difficult to strike, and not apt to perish by evaporation, they should be moved into a greater heat, which will cause them to strike sooner. As to the time of making cuttings; when the young branch is in the act of extending by growth, the living principle is more active, the swelling of cellular matter that precedes roots is sooner formed; and often a plant will be found to strike from a young shoot, with its base or collar wholly separated from the stem, when a ripened branch will not succeed: they are more apt to die, and die more quickly (short little shoots, not far sprung, are least apt to die), but the living principle is more active, and, if kept close, evaporation is not so great, and some plants will strike in this way that will not by cuttings of the ripened wood. It is of great consequence with all cuttings, where the young branches are short, and will admit of it, to preserve the base or collar of the shoot; there is a nucleus of buds and fibres formed in the swelling at that place, from which roots are more easily produced, though they will do so at times from the fibres protruding between the joints. In cuttings intended to stand through the winter, they are better to be taken off a little before ripening, in order to allow the wound made by the cut to be healed, or skinned over before the growth is stopped; if left longer, they should be taken off in spring when vitality begins to be active, and as shortly before that as possible, in order that the wounds may be soon skinned over: the wounds also will heal more readily, if the operation be performed with a sharp knife, to lacerate the skin as little as possible.

On the section Propagation by Layers and Suckers, little could be added to what is already in the book. To tongue the layer at a side bud on the shoot is the most practically useful; any way will do, provided the tongue is kept open, and the part above the tongue made as perpendicular as possible, to allow the sap to accumulate, and form a swelling of cellular matter at the bottom of the tongue, from which the roots proceed. Thrusting the knife through the centre of the shoot is tedious, difficult to keep open, and more apt to injure the wood and bark, if the knife is not very sharp; and the swelling will not accumulate so readily,

having no bottom of a tongue separated as in the ordinary way. Ringing is tedious, and, unless with such plants as *Pæonia Moutan* (the bark of which is very thick and soft, and the branch does not tongue well), not needed. A little sand put round the cut prevents the wound corroding in heavy soils, and, by pressing on the bark as in cuttings, facilitates rooting. The layer should be kept steady from moving by a peg if necessary, to keep it pressed and firm to the soil. Suckers are facilitated by cutting over and wounding the stem; loose ground, in which the roots run freely, are best adapted for these plants. Lilacs, Scotch roses, poison oak, and most plants which sucker freely, do not succeed well by layers.

The sections Budding and Grafting are very full, and most of the details of practice have been noticed there and in this Magazine before. The success of budding depends greatly on the state of the stock; if this is growing vigorously, and the bark flies up quite freely on the introduction of the budding knife, the budding will hardly fail of success; if the young shoots of the stock are nearly ripened to the top, the bark is in the way of beginning to fasten to the wood; or if the shoots are small and weak, and the plant unhealthy, the bark most likely has not risen at all: in either case, the bark will not rise freely from the incision with the handle of the knife, the sap is not circulating freely, and it is in vain to attempt introducing a bud by forcing up the bark. The bud should be chosen from a vigorous young plant; the shoots from old trees have not so much sap or vitality; and the bud should be chosen when the bark is beginning to assume a ripe colour: if too ripe, it does not rise so freely from the bark, and vitality is beginning to get dormant; if too green, it is apt to perish before uniting to the stock. The buds should be tied as soon as possible after the operation, to exclude air from the wounds; but if the stocks are vigorous, drawing very tight is not of so much consequence here as in grafting. When buds are nearly ripe, in which state they succeed best, the piece of wood which unites the bud to the branch is apt to break off far in, and leave the appearance of a hollow eye. Some operators attach great importance to this, and say that, though the bark live and unite, the bud will not push in the spring: but I have frequently inserted buds with very hollow eyes, and marked them for the purpose of experiment, and they always pushed as well as the others; the sap of the tree should soon fill this hollow. Much of the success also depends on having the edges of all the cuts smooth, and the operation done as speedily as possible: if the edges of the wound are rough, the vessels of the liber, where the living principle is most active, are bruised and lacerated; and, if long exposed to the air, they begin to spoil. The common method of extracting buds is to

cut away a piece of the shoot, and afterwards extract the wood ; but this destroys the very sharp edge of the knife, and the cut will invariably be found more or less rough. The bark should be cut all round the bud to the shape and size wanted, and the thumb pressed against the cut portion, at the side of the bud : if the shoot is growing and healthy, the bud will separate freely, and there will be no laceration of the edge ; the bark will be cut as smooth as a piece of cheese, and the edge of the knife will be kept sharp, as no wood needs to be cut through. As far as mechanical operation is concerned, this cutting smooth is of far more importance than any method of inserting the bud ; if the bud does not squeeze freely off the branch with the side of the thumb, it is very doubtful of succeeding. In general, buds are inserted with the intention of ripening in the stock in the autumn, and the stock being cut over in spring, to allow the bud to push ; but some, as the variegated sycamore, which ripen their wood early, succeed best if done early, and the bud allowed to push a small shoot in the autumn ; others, as the striped-barked maple, which are late in ripening their wood, succeed best by being budded in spring, when the sap has begun to flow ; as camellias are done. Evergreens, as rhododendrons, succeed best in the full growth of summer, when the sap is in full flow, and are the better of a little bottom heat in the frames to excite the plants.

Much of the success of grafting depends on keeping the alburnum, or newest layers of wood and liber, or inner bark of the stock and graft, closely united and pressed together, till a complete union takes place ; it is in the bark and soft wood, as observed by Dr. Lindley, that the development is most rapid, though all the cellular tissue is capable of uniting. For this purpose they should be as near of a size as possible, and the slice from each should be very small, allowing as much of the alburnum as possible to remain on both ; it is there where the sap rises ; and if the slice is made, either in graft or stock, through to the heart wood, the ascent of the sap is stopped, except by the edges. The graft should not be put on till the stock has commenced to grow, when the new layer of inner bark is about to be formed, and the efforts to unite commence ; both stock and graft are apt to dry and shrink, or cling, and thus part from one another, if done long before the commencement of growth. The grafts should be taken off before they begin to spring, and their ends inserted in damp earth ; as they will cling more if taken off after they have begun to swell by growth, and thus part more from the stock. Also, if the living principle is set in motion by the commencement of growth before taking off, and then checked by taking off, or by cold weather succeeding

warm, the graft will perish more readily than if the growth of the stock had commenced first, and the graft been fed from the union of the tree : for this purpose, the grafts of deciduous plants should be taken off before they begin to swell in the bud ; as, if growth has commenced, it will proceed farther in the graft, though off the plant, and be hurtful. Neither seeds nor cuttings will perish near so readily when in a dormant state, as when life is set in motion, and then checked. To prevent clinging or shrinking, we should choose well-ripened wood. The young shoots of young trees, or the bottom growths of old trees, are generally more vigorous than the extremities of old trees, vitality is most active in these young shoots ; but in grafts that have the young wood soft and apt to cling, as beech, &c., we should choose strong, vigorous, two or three years old wood. Many grafts that succeed with difficulty, as beech, oaks, &c., if the grafts are retarded, the old wood chosen, and the stock allowed to spring before grafting, will succeed in this way, when they will do so in no other. Much of the success, however, depends on the warmth of the weather keeping the sap flowing. Moist warm weather is good ; but heat is the principal requisite, the stocks being already established ; and wet weather is very often cold in spring. The mechanical part of the operation depends on the slopes of the cuts being made to fit one another exactly, which is easiest done by choosing the slopes of the graft to fit those of the stock as nearly as possible ; by thin slices being taken off each ; by using a thin-backed, broad-bladed, sharp knife ; and by drawing the hand straight without twisting when making the cut. The graft and stock must be hard pressed together, without shifting, in the tying ; which is best done by a smart hitch, or pull, every time the wet bast ligature passes the graft in the act of tying, and not by continued pulling. The above remarks apply chiefly to whip-grafting, which is the most common. Crown-grafting is that most practised for old trees ; and the necessity to take off the grafts, and allow the stock to push, is here absolute ; as the operation cannot be performed properly till the bark rises freely from the stock. When the bark rises freely, success is very certain in this way, if the grafts are strong, and not sprung ; as the flow of sap causes union to take place speedily, and the strong bark keeps the graft in its place. If the bark and wood of the stock do not separate freely, it is in vain to attempt grafting in this way. Grafting soft evergreens, as daphnes, &c., is best done by waiting till growth has fairly commenced, and inserting the graft in the manner of a bud, by opening the bark of the stock. The grafts of these must not be taken off till needed, as they are not dormant like deciduous grafts, and more apt to perish.

The bark will not rise till growth has fairly commenced; and dull, cloudy, moist, warm weather suits best: if dry and sunny, they should be shaded. The grafting of pines, in which a few leaves are left on the top of the stock to draw up the sap, is minutely described in the work. The same retention of leaves on the top of the stock, to carry on the growth and draw up the sap, is useful in the grafting of most soft evergreens, and has lately been ingeniously applied to the grafting of vines, by Mr. Gowans of Calder House. The rest of the section, on grafting on dwarf stocks, which diminishes the quantity of sap, and renders the tree precocious; its effects on the quality of the fruit, &c.; also on herbaceous or Tschudy grafting, grafting on the root, &c., are interesting.

On the section Pruning, the activity of the vital principle should be taken into account, as well as the quantity of food deposited. By taking away part of a branch, we take away so much food that had been deposited for the use of the plant; but if, by this part being cut, we increase the activity of the vital principle, we may ultimately produce more wood than would have been done by letting it stand: hence, the common phrase of pruning for wood and pruning for fruit is true upon this principle. When plants are allowed to shoot up without check, if healthy and vigorous, and sown in the place where they are to grow, and the soil congenial, the activity of the vital principle, perhaps, remains undiminished, and the plant continues to thrive: but, if checked by transplanting, or want of nourishment, or other cause, it gets what is called *hidebound*; the vital principle gets feeble, and, to stimulate it again into activity, nothing is more effectual than cutting over, as is well known to foresters, who universally resort to this practice to renovate the growth of the oaks planted in the forest. After being a few years planted, they head them down, select the strongest shoot when they spring from the root, and, in a few years, the plants thus managed are incomparably larger than those left untouched; stimulus is given to life by the young shoot made after cutting, which continues afterwards, and produces a thriving healthy tree, in place of a stunted slow-growing one. Peeling off the old hardened outer bark from fruit trees also gives a stimulus, by admitting the more perfect action of the light and heat; but it must make the tree more liable to checks. This cutting over is also resorted to by nurserymen, to stimulate growth in crooked layers, and all lazy-growing *hide-bound* plants, which are not naturally so. Cutting the young wood back, and cutting in the small roots to produce more fibres, keep the plant more healthy and vigorous, and, from the bushiness of the root, more fit to transplant. In pruning fruit trees, if wood is wanted, the young

shoot must be cut down to within a few joints of the bottom ; the buds below will start with great force and vigour, and, the living principle being more active, the branch so managed will be found to have produced, at the end of the season, a great deal more foliage and wood than a shoot not headed down : this is called pruning for wood, and must be done judiciously ; if large arms are removed, the food taken away by a large branch may be more loss than the greater activity of the growth will make up for. In pruning for wood, it is best to cut young shoots ; in old branches the buds have become sunk and latent, sometimes they do not start at all, or, if they do, it is more feeble than the lowermost buds on young shoots ; and much of the success depends on the force and stimulus given to the vital principle. In pruning roots, a young fibre of a root, if pruned judiciously when in a dormant state, will from the same cause produce more young fibres in the ensuing season, than if left unpruned : and hence the reason of nurserymen pruning the roots of their young trees ; it increases the quantity of fibres, the plant has more sources of nourishment, and is more easily transplanted. When a stock, planted out for budding or grafting, is pruned in the roots, and the young shoot headed down, the plant starts with great vigour, and there is far more chance of the buds and grafts succeeding ; when the fruit tree is headed down and kept full of young wood, it is far more manageable, and the plant will not sell unless the wood and bark are young and vigorous. If large arms of the roots are removed, the young fibres do not start so freely from old as from young roots ; the quantity of small fibres removed is more than can be compensated for a time by the new roots formed, and the consequence is a check to the growth of the tree, which causes it to furnish less sap to the branches ; and this smaller quantity being more easily elaborated, the more perfect state of flower buds is produced, and the tree becomes precociously fruitful, and less vigorous. In pruning the young wood for fruit, the shoots should be left long and but little shortened, and not starting so strongly as from the lower buds when cut for wood, the smaller quantity of sap attracted is better elaborated, and fruit buds are more likely to be formed. In roses and other plants that flower in the wood of the present year's growth, if the young shoots are cut down to within a bud or two of the bottom, and the plant vigorous, we are more likely to have wood than flowers or fruit ; if left very long, we are likely to have too much flower, and little wood, and the plant becomes unhealthy : the same applies to vines. In plants that bear on the one-year-old wood we must cut so as to have plenty of young wood ; in peaches that are too vigorous, we must cut less, and endeavour to produce fruit, which is the best check on wood. In trees that bear on the older wood, we must

endeavour, by giving extent to the tree, and not making the border too rich, to keep up a healthful, not too luxuriant, state of growth. To prune away vast quantities of young wood every year, is only to encourage more in the next. We should endeavour, by laying in as many of the shortest lateral branches as we can, to get as many fruiting natural spurs as possible, which are far preferable to large forced ones; the fruit is better, and we may also have the quantity greater than when the trees are managed with long spurs and naked branches; and when the tree has good crops of fruit, it checks the too luxuriant growth of wood. All pruning is best done when the living principle is in action, the wound is then easily healed; if done in winter, the shoot will generally be found to die back a few joints, which it would not do if in a growing state. Hedges should be pruned before the growth stops, and when cut over should be done after growth has commenced, to give the wounds the advantage of growth to heal them. Dr. Lindley illustrates the use of early autumn-pruning in the vine, by the quantity of sap collected in winter being distributed among the shoots left, and not partly also among those cut off. It is customary to cut vines and other fruit trees after they are fully ripened; but if it could be convenient to cut them rather before the fall of the leaf, it would skin the wound over and prevent bleeding. Much of the necessity of pruning, or forbearing to prune, depends on the nature of the fruit tree: some sorts that bear freely are the better of a good deal of pruning, to keep the tree vigorous, and the fruit better in quality, as gooseberries, &c.; others, that grow naturally too much to wood, and are longer in fruiting, should be allowed to extend till nature has exhausted itself, and the tree begins to come to maturity, when small well-ripened fruitful shoots are the consequence. Such trees should not have the soil made rich, to encourage their growth too much; but it is better to give the tree room to extend itself if possible, than to force it into precocity by unnatural means; the tree is then apt to get unhealthy, and the fruit is never so fine in quality. Provided we could command heat and light in sufficient quantity to ripen the wood, we might make our borders rich; but as long as these are limited, so also must the food be limited: for healthy vigorous-growing trees, it only retards their maturity to furnish the roots with rich compost. Depressing the branches by checking the upward flow of sap, and causing less quantity to be sent to the bended shoot, checks its growth, and hence is a good means of balancing the growth of a tree, when one side is more luxuriant than the other; it also encourages the formation of flower buds. Bruising or pinching the end of the shoot, by the check it gives from the wound produced, and stopping the leading of the shoot, will have the same effect. Depressing is

best; but, if the branch is very vigorous and much bent, it will start an upright growth from the top of the bend, and very vigorous shoots should thus be bent only slightly at first. The ringing of a branch also has the effect of checking its growth; and, there being a less flow of sap to the branch, the action of the leaves, light, and heat elaborate this small quantity more perfectly; the wood will be better ripened, the alburnum and all its parts more concentrated and denser, because the branch has not lengthened and extended into wood; and the energies of the leaves have been employed in the elaboration of the sap. The bud, which, for want of sufficiently elaborated nutriment, might have, but for the ringing, been only a leaf bud, will now be swelled out and organised into a flower bud, and the branch become precociously fruitful. The same fruitfulness is produced by taking off a large arm of the root, which is a proof that lessening the quantity of sap in a luxuriant tree is the way to make it fruitful: depriving the tree of a large portion of its roots lessens the quantity of sap; and if accumulation of sap were the cause of fruitfulness, this experiment is exactly counter to what ought to be done. It is concentration and elaboration of the sap, let the quantity be what it will, that produce fruitfulness; and we must be careful to prevent the supply of more sap than can be properly elaborated, by making the soil poor for luxuriant-growing trees, and laying the roots dry; also giving sufficient extent, to prevent the necessity of having recourse to unnatural means to produce fruitfulness. For the other effects of ringing, in increasing the size of the fruit, if done the year the fruit is produced (and not the year previous, as above), by the accumulation of the sap prevented from descending, and the effects of all the different methods of pruning noticed, recourse must be had to the work itself. When talking of pruning and training, we are naturally reminded of the cold feet and uncomfortable nature of the occupation, and the remedies you have frequently suggested of wooden shoes, &c.; but, if a single fold of Macintosh waterproof cloth is put between the insole and outsole of a common leather shoe, and a fold between the plies of a double upper, provided the shoes are strong, and the leather good the feet will be as dry and comfortable as if walking on a deal floor.

In the section Training, the effects of depressing in causing fruitfulness, and of extension being necessary for the same purpose (the shoots, as before stated, getting shorter and better ripened), are treated at great length, and interesting descriptions of vines, &c., so treated brought forward. The tendency of old trained trees to produce young shoots at the bottom is noticed, and attributed to the obstruction of the flow of sap in the densely ripened old wood; perhaps it is also partly owing to the great

quantities of breast wood annually pruned off. Some of our best gardeners now lay in much more of the shortest of the young wood than formerly; it gives extent to the tree, and produces better fruit than long spurs; and will prevent the necessity of the tree pushing young shoots from below. When trees get too indurated and dense in the tissues, the old practice of peeling off the outer bark should give relief. The trees so peeled of old by Dr. Lyon, in his garden at the bottom of the Canongate, Edinburgh, were very healthy, and had always plenty of blossom and fruit; it was his practice to smash off the greater part of the blossom with a broom, having always more than the tree would carry; his trees were principally standards. The effects of walls, in producing a better climate, and consequently better-ripened wood, and more fruitfulness, are fully entered into; and their effect in bettering the quality and size of fruit chemically described. The advantages are most felt in fruits abounding in juice: some dry fruits are rather made worse than better. The proposals of some, to increase the heat in walls by blackening the surface, are noticed; but as those substances, as black, which absorb heat most readily, also radiate or part with it most readily, the black wall, though warmest through the day, will be coldest at night, which is very prejudicial; and, as the fruit and leaves of trees trained to the wall are always at a small distance from the wall, they should get more heat from reflection than absorption, and a white colour I should think best. As noticed, however, in the section Temperature, the best way to have the heat kept up at night, is to get as much confined air generated about the wall as possible, and the upward radiation as much prevented as we can: for this purpose, walls built hollow, of the most porous brick or stone, and broad wood copings, as formerly recommended by Mr. Loudon in this Magazine, are, next to covering, the best devices. Much of the good of coverings is often lost, and even harm done, by allowing them to be too much on.

In the section Potting, the bad effects of pots in cramping the roots of plants, exhausting the soil, exposing the fibres to drought by the sides of the pots, for which double pots as a remedy are pointed out; the bad effects of potting pines, and other forest trees, by giving a spiral direction to the roots, which may continue afterwards, and prevent the roots from spreading and getting a firm hold of the soil, and render them liable to be blown down by winds; the good effects and necessity of complete drainage in the pots, and frequent shifting; the tendency to cramping the roots, and stinting the plant in producing flowers; and the effects of exposure of the fibres of the roots at the sides of the pots, in improving the quality of some fruits, are pointed out; all of which will be found very interesting.

In the section Transplanting, the theory of the process is cor-

rectly laid down. Deciduous plants will suffer least, if removed when in a comparatively dormant state; in fact they should not be moved in any other; and to get the benefit of any growth that may take place by the root in winter, the sooner this is done after the plants are ripe the better. But some grounds will not admit of planting early, where the soil is adhesive, and not properly drained, and perhaps the nature of the levels such that it will not admit of draining properly; whenever a slit or pit is made in such ground in the autumn, and the tree planted, the water collects at the cuts in the winter, and rots the roots, and the plants perish. In some situations also, exposed to heavy winds in winter, the stem of the plant, before its roots are fixed, gets knocked about with the wind; the effect of which is to form a hole around the neck of the stem, the rain, frost, and drought penetrate, and the plant is very apt to perish. A partial remedy for the storm in high lands, if the surface is bare and the grass not rank-growing, is to plant small plants; if very bare, however, it may be heaved by the frosts and thaws, and the small plants thrown out; or if the grass is strong, a small plant may be overtopped in summer and perish, and large plants be required; even small plants also will suffer, if very much exposed. In all situations, such as above noticed, the sooner the plant commences to grow after planting, the less will be the risk; and late planting, provided the plant has not begun to spring, nor to form young roots, which it will do rather before the buds begin to swell, will generally succeed best. Evergreens are not generally planted in such situations, and large plants of these, if not exposed to heavy winds, or supported against them, will undoubtedly, as Mr. M'Nab says, have most success, if planted in soft weather in the beginning of winter; the roots get settled in the soil, and the plant comes away more vigorously. Wet weather, as he also states, is indispensable to the success of the operation, it settles the roots in the ground: if the weather is only moderately wet, the plants, as soon as planted and trod, should be saturated from a watering pan, round the roots, before the last stratum of drier earth is put on. Small seedling plants of evergreens, however, planted out for nursing, are more apt to perish from inclement weather in winter; and seedling laurels, hollies, Scotch firs, &c., put out in autumn, will be found to suffer more from the severe frosts and thaws that occur in February and March, than the same plants standing on the seed-bed; the roots of the latter are more fixed in the ground, and the living principle being stronger, from the plant not being enfeebled by transplanting, it does not suffer so much from the cold. The plants bedded out in the autumn apparently grow very little in winter, at least no new fibres are formed till the air gets warmer in spring; the cuts that are made by the spades in the ground, in the act of

forming the row to plant the seedlings, allow the frost to penetrate, which heaves and swells the ground still further, so that the alternate frosty nights and sunny days of a cold dry spring often make sad havoc among the small plants; and small plants of evergreens, planted out in moist weather in April, or even in May, commence to grow as soon as they are planted, and hence often succeed better than those planted in autumn; much of this will, however, depend on particular situations: in the West of Scotland, March is generally more or less attended by a succession of dry frosty weather from the east. If severe frosty nights and sunny days do not occur in spring, and the winter is mild, the autumn-planted will succeed best, from the roots being washed into the soil by the winter rains. In sending small evergreens, or even deciduous trees, to a distance in winter, the plants are greatly benefited by having the fibres of the root drawn through a thin puddle, and moss wrapped round the roots to keep them damp; if the quantities are great, and the plants soft, and closely packed, dampness is apt to cause them to heat: the outside moss should be dry, and care taken in packing, by mixing branches of deciduous trees or otherwise, to allow a circulation of air, or ventilation, to take place, which carries off the heat before it accumulates, and checks decomposition. Deciduous trees are not so apt to suffer from damp, and should not have so much circulation of air, to dry and evaporate; if the drying continue till the bark begins to shrink, they will most likely perish. Packages sent by sea are not so apt to suffer from drying, from the greater moisture of the air. When plants reach their destination, and have been long detained and dried, it is often the practice to saturate the ground they are planted in with water; but Dr. Lindley observes, excess of water in such cases is dangerous to the languid powers of the plant and roots; and to water sparingly, shade from a hot sun, and moisten the bark and under side of the leaves, if evergreen, are more likely to succeed. Plants that are wiry and hard in the roots, and dense and well ripened in the wood, are more tenacious of life than such as are softer, and will suffer less from exposure; the thorn is an instance of this, it is not easily killed. The necessity of preserving the fibres of the root uninjured, as much as possible, and carefully cutting the wounds clean, when any bruises are made, is clearly and forcibly pointed out: when the roots are far extended in the ground, it is difficult to lift them without injuring the roots; and for this reason young plants should be as frequently as possible transplanted in the nursery before planting out finally; it checks the roots from extending, and keeps the young fibres more close together; it also gives the plants a more hardy habit. Plants removed from a thick plat, where the confined air keeps up heat, are, when planted out separately, like

plants removed from a green-house to the open air. For the purpose of keeping the roots close, and making the plants hardy, a close adhesive soil is best to transplant finally from; but, at the first planting out of seedlings, a loose free soil is indispensable: a cold clay soil is many degrees lower in heat than a warm siliceous soil. Growth will commence fully a month earlier in light free soil; the fibres run more freely; the ground keeps closer in dry weather, and does not open into rents admitting the drought, as a clay soil does; heat and moisture are better retained; and seedlings should be planted in rich light soil, and when a year or two old removed into adhesive soil, before fully planting out. Where very large plants are moved, and the roots necessarily a good deal hurt, we have Mr. M'Nab's experience to warrant us, that the tops should also correspondingly be mutilated or cut, to prevent the action of the complete foliage from being too excessive for the mutilated roots to supply.

In the Preservation of Races by Seed, the method of obtaining extra-fine varieties, by saving seed from the best, and picking and rousing these again and again, to fix the quality in the seed, by the tendency of all seedlings to come like their parent; to preserve the race distinct, by preventing intermixture of the flowers of others nearly allied; to get wheat, &c., to ripen earlier, by getting the seed from earlier and drier soils, using the smallest seeds, &c., are all clearly pointed out and illustrated from theory. The operations quoted from the Indian gardeners, to improve the varieties from seed, are similar to the methods pursued in obtaining double flowers, namely, to check first and then luxuriate; the luxuriance has all the greater effects from the previous check. The instance mentioned of Brussels sprouts degenerating, when the seed is saved at a distance from Brussels, is similar to that of the early Dutch horn carrot, which will not come true from seed saved in this country. There must be some peculiarity in the soil or climate of Holland, which produces those and the hyacinth roots so much more perfectly; in the case of the latter it has been attributed to the presence of saline water, at a certain depth in the soil, the land having been gained from the sea by embankments.

In the Improvement of Races, the necessity of getting seeds from healthy parents is clearly pointed out. If more attention were paid by nurserymen in selecting their seeds from the most healthy trees, and if planters would encourage this, by a better price paid for these, a great improvement might result. In the case of Scotch fir we might not need to have recourse to the Highlands and Hagenau for seeds; unless these are healthier plants, it will be no improvement. Health is different from luxuriance, as the fattest animal is not always the healthiest, and a healthy moderate-growing tree will produce the best

wood. The Hagenau Scotch fir is a slower grower than the Highland, or common, Scotch fir, and is said to produce better wood.

In Hybridising and Crossbreeding, the methods employed by Mr. Knight, Mr. Herbert, and others, are detailed and commented upon: there seems much to learn yet on these subjects; and the observations from experience, promised by Mr. Beaton, should be valuable. The endeavours to blend the qualities of precocity, size, flavour, &c., of one variety with another deficient in these may, however, be productive of much benefit, though we cannot yet say which qualities are most affected by the male parent, and which by the female; we may also make them earlier and hardier, and improve their fruit in size, by the treatment we give to the plant or parts of a plant we save the seed from; but this belongs rather to the former section. On the doubling of flowers noticed in this section, I have already stated my opinions in the section Action of Flowers, it is the method practised by the best growers of double stocks. Varieties are more often got from accident than theory; but theory may guide us in our efforts, as, however accidental any production may appear, it must have a cause which theory may enable us to imitate. Some accidental varieties, as variegated or curled foliage, mossy branches or calyx, are not likely to come from seed (though the copper-leaved beech has been got in that way), and varieties of this kind must be propagated from the individual plant; the most curious instance of accidental varieties is that lately noticed in this Magazine, of the purple laburnum. The instance of the black eagle cherry, when first raised by Mr. Knight, being thought useless at first, and afterwards becoming rich, is an instance of the effect of soils and situations, and perhaps stocks, on fruits, which is not easily accounted for; in the same garden, and close to one another, the same kind of fruit, though both are budded from the same shoot, will be very superior on the one tree to what it will be on the other; the black eagle cherry is said to have very inferior fruit in some situations.

In the Principles of Resting, there is a long detail of the principal climates from which our exotic plants are drawn, and their effects on vegetation. The effects of a very dry warm atmosphere, as in forcing, in causing an inspissated or concentrated state of the sap, thus producing flowers and fruits; the advantage that may be taken, by resting and forcing at different periods, in altering the periods of producing fruit; the necessity of diurnal as well as periodical repose; the great difference in tropical countries of the heat by day and the heat by night, pointing out the necessity of nightly rest from excitement, and the error of keeping up too great a degree of heat in our houses

by night, are all largely and minutely treated and forcibly illustrated.

In the last section, of Soils and Manures, the fact that some plants will thrive on very different soils is brought forward; also the little or no difference to be found in the organic state of different species of the same genus, that will not thrive on the same soil; and consequently the little benefit to be derived, as yet, from the analysis of soils and plants. Generally speaking, plants with bushy roots and strong fibres require rich food and plenty of water, as the ash, lilac, privet, balsam, dahlias, celery, leeks, &c.; and if the soil is light, they will require more manure and water than in clayey soils. Plants that have hard wiry bare roots, as the beech, pines, cistus, larix, melons, turnips, onions, &c., require a drier soil, and not so much manure. Plants with very small hairy fibres, as birch, and most of the American shrubs, are fond of a soft adhesive soil, which their roots can penetrate easily, and which will adhere to them; if leaves are rotted to the consistence of peat, they will grow most luxuriantly among these, either wholly or mixed; they grow well among peat, but it gets dry and spongy on the surface, and is the better of being mixed with loam and white sandstone pounded; they will also grow well in soft adhesive loam, especially if mixed with rotted leaves and sand; a dry stony soil, or a very stiff hard clay, is the worst. But there are many exceptions: the yucca, which is very strong and fibrous in the root, will not thrive well in damp soil; the rose and thorn are both bare-rooted, yet the first can hardly be satisfied with manure, and the last thrives always better in wet than dry seasons; the roots of oats are, if any thing, smaller than wheat, yet the former thrives better in a wet season than the latter. The genus *Abies*, or spruce, is nearly allied to the *Pinus*, or fir, and not much apparent difference in the roots; yet the different species of spruce thrive best in a damp soil, the fir in dry soil. There are constitutional differences in the organisation of the tissue and epidermis of plants, which analysis cannot easily point out; some plants (and even different parts of the same plant) will secrete poison from the same sap from which others will secrete nutritive food, as some animals will eat with impunity the food which will poison others. Roots will be affected by the warmth and cold of a soil, and the quantity of air which penetrates to them, as well as the state of moisture, and quantity of nutriment. Plants grown on dry loamy soils are more solid in the tissue, hardier, and less liable to be affected with changes, and are best for transplanting. On the section Bottom Heat, we took notice before of the coldness and lateness of clayey soils, and the warmth, earliness, and rapidly exhausting nature of sandy soils. Much of the bene-

fits or losses derived from these soils depend on the heat and moisture of the season : in a wet cold summer, the sandy soils do best ; in a warm dry summer, the clayey soils. Clayey soils may be greatly benefited by draining, digging deep, pulverising, and mixing with decomposing substances. Sandy light soils, in some dry seasons, require treading and rolling to retain the moisture. The most permanent and beneficial alteration, where possible, is the mixing of the two together. In composts for pots, plants will thrive in very different mixtures, according to the heat and ventilation they are exposed to, and the water they get. Plants in light composts require more water and attention, and will grow more quickly ; while those in loamy composts, if well drained, are hardier and firmer, and do not need so much attention ; a medium is safest for plants, the cultivation of which is not well understood. Oxide of iron is the most hurtful principle to vegetation in soils, and may be easily detected from its red colour ; the best corrective for this is lime, which neutralises the acid.

Much has been said about manures by chemists ; but the benefits hitherto derived from the details of chemical analysis in practice has not been correspondingly great. The conclusion arrived at by Sir Humphry Davy was, that all manures should be put into the ground in as recent a state as possible, while, in practice, the opposite plan is thought more beneficial. Most practical men are of opinion that the ammonia first given off by manures is very prejudicial to plants ; and manure, when kept in a heap, does not lose much besides this, and is more perfectly rotted in a heap than when spread in the soil. A mixture of horse and cow dung, rotted to the consistence of a black oily peat, is thought the most economical and advantageous way of applying manure. Chemical analysis shows that all the parts of plants are chiefly composed of carbon, hydrogen, and oxygen ; nitrogen has lately been more often detected than formerly ; and small quantities of other substances, as silex, and other stones, metals, &c., are sometimes found ; but the first three are the component parts of all plants, and the food of plants should therefore consist of substances furnishing these in greatest plenty. Hydrogen and oxygen are furnished by the decomposition of water ; oxygen and nitrogen from the air. Carbon is produced from animal and vegetable substances, being only in small quantity in the air ; but, before it can enter the spongioles of the roots, it must be converted into carbonic acid, which is produced by fermentation causing the oxygen of the air to unite to the carbon, and form carbonic acid : hence the necessity of a proper degree of fermentation in manure, and the great benefit of applying yeast, and other fermenting substances, to manures. In the act of fermentation, too much heat is sometimes evolved,

and is hurtful, and hence the necessity of turning dunghills, especially if all composed of horse dung, and in warm situations; too much cold rain checks fermentation, and hence the benefit of covering from this. Before carbon can be admitted into the spongioles of the roots, it must also, it is said, be made soluble, by being mixed with alkalies into a saponaceous matter. The alkalies necessary for this purpose are contained in the manure, or may be increased by applying lime, salt, and other alkaline substances. The dark brown-coloured substance in well-rotted manure formerly denoted vegetable extract, but now humus is formed of the proper mixture of these substances, and is the essential requisite in the food of plants. It is this substance which gives the colour to the drainings of the dunghill; and, being in a soluble state, we see hence the great benefits derived in watering with manured water. Dung from high-fed animals is most superior. Bullock's blood is rich in carbon, and should be mixed. A simple easy method of knowing the quantity of humus in soils was lately given in *Paxton's Magazine*. Sift and wash the soil repeatedly, till all the impalpable powder it contains is separated with the water. Put this into a long narrow glass vessel of water, and shake it up well from the bottom: the alumina will fall to the bottom, and deposit quickly, while the humus will float on the top for a considerable time. We may thus have a pretty rough guess of the quantity, both of alumina, or clay, and humus contained in the soil; and without a due proportion of the first, to retain humus and moisture, no soil will be rich. The presence of animal matter in the soil may be detected by the smell given off, similar to burning feathers, on burning a portion of the soil; and the presence of chalk or lime may be known by its effervescing with an acid, and giving off air-bubbles and heat. For a complete analysis of soils and manures, so far as at present known, as useful in practice, I would refer to that lately given in the *Quarterly Journal of Agriculture*, by Dr. Madden; and, as the table he gives of their actions contains so much information in a little space, I have subjoined a copy of it.

In the work before us, Dr. Lindley confines himself to a statement of their general principles, and the manner in which they act. He also notices the other metals and minerals, &c., found in some plants, and the necessity of these in the soil to the perfect growth of the plant. He also notices the best times of applying manures, which, he says, are October for grass lands, and spring for cultivated crops; also the necessity of applying manures to the extremities of the fibres of the root, to the young spongioles, and not at the bole of the stem, which he humorously likens to feeding a man through the soles of his feet.

Table of Manures, arranged according to their Action, by Henry R. Madden, Esq., M.D., Edinburgh.

	Manures which act by yielding Organic Matter to the Plants.	Manures which act by yielding Earthy and Saline Matter to Plants.	Manures which act on the Organic Matter of the Soil.		Manures which act by altering the Texture of the Soil.	Manures which act specifically upon certain Crops.		Manures which act as Stimulants.
			By Fermentation.	By Chemical Solvents.		From containing peculiar Saline Matters.	From containing peculiar Organic Matters.	
Vegetable.	Rapecake Malt-dust Steepings of flax and hemp Green plants Straw Woody fibre Tanner's spent bark	All more or less	All slightly					
	Farm-yard dung	Farm-yard dung	Farm-yard dung					
Animal.	Dead animals Fish Blubber Excrements Urines Horn Hair Woollen rags Feathers	All in some degree	All more or less			Horn	Rapecake Malt-dust Horn	
Mineral.		Chalk Gypsum Marl Saltpetre Commonsalt Kelp		Kelp Lime(hot)	Marl Chalk Lime (mild)	Gypsum Chalk Kelp Salt Saltpetre		Saltpetre Common salt
Mixed.	Bones Composts	Bones Ashes Soot Composts	Bones Composts			Bones Ashes Soot Composts	Bones	Soot

I have thus gone through all the divisions of the treatise. The subjects discussed are very important, and it has necessarily been tedious; but I have endeavoured to condense as much as I could, and hope the example I have set will soon be followed by others. Let us differ from each other as much as we can, when we can give reasons for our opinions; let us also weigh well one another's reasons, and not consider our neighbour must be wrong, merely because he differs from us in opinion, and mutual benefit will be the result, as every practical man has his own sphere of operations, to which, from habit and necessity, he is most attached, and has opportunities of observation on certain subjects which others do not possess; and when any important observation has been made, it should not be kept hid.

Kilmarnock, August 1. 1840.

REVIEWS.

ART. I. *Transactions of the Horticultural Society of London.* 2d Series, Vol. II.} Parts III. IV. 4to. London, 1837 to 1838.

(Continued from p. 417.)

24. *On the Cultivation of the Melon in open Frames.* By John Williams, Esq. C.M.H.S. Read February 21. 1837.

“ Nothing can be more simple than the construction of my glass covering. I sink a shallow pit about 9 in. or 1 ft. deep in the ground; a strong wood frame is made the size of the intended bed to support the glass. My frame is 18 ft. long, by 8 ft. 3 in. wide; each light is divided into two parts, the upper part being the shortest. By this division the lights receive less injury in being removed; and, as wood props soon decay in the ground, I procured some small cast-iron pipes 2 in. in diameter from our Gas Works, and by cutting the pipes a little above the moulding, this circular projection affords a secure shouldering for the wood frame to rest on; the lower end of the pipe goes into the ground, and is secured in its place by a few small stones rammed round it in the way of paving a street. Four long pipes support the upper, or north side of the frame, and four short ones, the lower or south side. The lower part of the pit is filled with a mixture of old leaves, the winter prunings of raspberry plants, and other twigs from wall trees and shrubs which every garden affords in the spring; to these I add a little horse litter and the first mowings of grass lawns, dusting in a little lime in powder, which hastens the decomposition, kills insects, and keeps up a durable bottom heat for some weeks. I find in the autumn the melon roots go through the whole, down to the bottom of the pit, and, when removed in the following winter, it affords an excellent compost for the garden. The melon plants are raised in small pots, each plant being in a separate pot, the seed being sown in March or beginning of April; this will give time for each plant to be stopped twice in the seed-frame; and they will then afford female flowers from the lateral shoots, very soon after they are planted at the end of May. I usually, when first the plants are turned out of the seed pots, simply cover them with hand-glasses, say the first fortnight, each glass being furnished with a night-cap of matting to prevent the radiation of its accumulated interior heat in clear nights. The glasses of course are raised on one side, every sunny day, to harden the plants as much as possible; and at the same time their use saves the trouble of moving, and endangering the breaking of the frames. The bottom compost is covered with about 9 or 10 inches of soil, and this soil with slates, the principal runners being carefully spread, and pegged down, that each leaf may receive its due portion of light. The glass, when the bed is settled down, should be from 16 in. to 18 in. above the slates, so as to give room for the leaves to expand and receive motion from the wind, and the exhaling moisture to be carried away. As the bottom heat declines, I keep a supply of grass mowings, fallen leaves, and other garden refuse, as a lining on the north side. Green glass is much to be preferred to crown glass, the leaves are less liable to be burnt, in spots, by the sudden exposure to light in showery weather. The plants require no water at root after they have first got rooted in the bed, nor any syringing with water on the surface of the leaves; I found the latter did injury. One single dusting of flowers of sulphur thrown amongst the leaves in a calm morning or evening, by means of the newly-invented portable fan engine, I found, last summer, effectually kept off the red spider and thrips. Every gardener who saw the plants growing expressed surprise at their healthy appearance, and the abundance of fruit.

“ Should this mode of cultivating melons be adopted, I have no doubt of

its succeeding; and from a trial I made with a late plant of the Ispahan melon, last summer, I have reason to think that this, and all the Persian varieties, except those which are liable to crack, can be matured by the end of August, or beginning of September, and afford a supply, till the middle of October, of very superior quality to any raised in close frames."

25. *On the Cultivation of Figs.* By T. A. Knight, Esq., F.R.S., Pres. Read February 21. 1837.

"I made, during several successive years, attempts to ripen one of these, the Nerii fig, which is one of the best, if not the best, of the figs of Italy: and I have ultimately succeeded; and as the mode of management which I have adopted is peculiar only, and not difficult or expensive, and nearly similar to that under which the peach and nectarine will be found to acquire the highest state of perfection, I have thought the following account of it worth communicating.

"I begin to heat the house in the middle of February, and continue the fire till the fruit has acquired its first swelling in May. If artificial heat be still applied, the first-formed fruit will fall off, and will be succeeded by other fruit, which will also fall off abortively. The fruit, therefore, after it has acquired its first swelling, is subjected to the influence of confined solar heat only, till it begins to acquire maturity. Much air is then given; and, if the weather be not dry and bright, artificial heat is, to a small extent, again employed, to prevent the mature fruit becoming mouldy; and I believe, upon the evidence of many friends, who are well acquainted with the merits of that fruit in different southern climates, that it is rarely seen in a higher state of perfection than when ripened in the manner above described. The fig is naturally ripened in shade, and in southern climates the birds and insects destroy, or injure, most of the best, before it has acquired its perfect state of maturity.

"The peach and nectarine acquire the greatest state of perfection in the climate of England (and the same treatment is, I believe, equally applicable to every species of fruit which requires the aid of artificial heat), if they are to a certain extent brought forward early in the spring, and subsequently subjected to the influence of solar heat only.

"I have succeeded in ripening the Nerii fig in a very considerable state of perfection, by introducing the trees in pots against the back wall of a stove in February, and removing them to a greenhouse, out of which the plants had been taken in the middle of May; and this may be successfully done, whenever the vines in the stove are confined to the rafters."

26. *Note on the Cultivation of the Cinnamon in England.* By Mr. William Buchan, F.H.S. Read February 7. 1837.

The common cinnamon is generally considered a stove plant, but Mr. Buchan for several years has grown one in a green-house conservatory, which he found to suit it much better, as did M. David, gardener to M. Boursault in Paris. In our volume for 1830, it is stated, that at M. Boursault's conservatory the cinnamon tree had ripened fruit, from which many young plants were raised. Mr. Buchan is of opinion, that, with very little protection, the cinnamon would stand the winter in the open air, in favourable situations in England; and in order that a trial may be made in such situations he has sent seeds and seedling plants from Blichfield in Staffordshire, where he is gardener, to the principal Botanic Gardens, and to various gardens in Devonshire, Cornwall, and Pembrokehire, where many of our green-house plants stand the winter without any protection whatever.

27. *Explanatory Notes respecting Six new Varieties of Vine recently introduced from Dukkun (Deccan).* By Colonel Sykes, F.R.S. Read June 21. 1836.

"A gentleman, lecturing to a Mechanics' Institute lately, stated that the

profitable cultivation of the vine was limited to countries having a mean temperature between 50° and 60° Fahr., and not within 30° of the equator ; whereas the whole of the six species adverted to are cultivated in Dukhun (Deccan), East Indies, between the 17th and 19th parallels of N. latitude, and longitude 73° 50' and 76° 50' east of Greenwich, at an elevation above the sea, varying from 1500 to 1800 feet ; the mean temperature of the year being from 77° to 78° Fahr., the mean temperature of the hottest months (April and May) 81° to 85°, and of the coldest 66° to 71° in December and January ; the thermometer having been known to rise to 110° in a tent in April, and to sink for a few hours as low as 37° in the winter months."

The six varieties cultivated in the Deccan, where they produce luxuriantly and without any difficulty, are the following :—

1. The Hubshee. An elongated, truncated, fleshy, black grape, approaching a juicy plum in firmness, but infinitely sweeter, the finest of all the varieties.

2. The Fukree. An oblong, musky, green grape, slightly fleshy, and not nearly so large as the Hubshee ; it fruits abundantly.

3. The Sahibee. A comparatively rare grape, yellowish green when ripe, oval, fleshy, slightly astringent, and of a dry flavour, though sweet.

4. The Bè Dana, or seedless grape. Small, globular, yellowish green, thin-skinned, and very delicious. It resembles the Kishmiss, from which the wine of Shiraz is made.

5. The Ahbee, or watery grape. Large, globular, thin-skinned, very juicy, green, passing to yellow, and terminating into a brown Indian red on one side.

6. This kind Col. Sykes cannot at present describe.

"The whole of the above grapes ripen during January, February, and March, and they are occasionally seen for sale in all April.

"The mode of treatment is different in different vineyards ; the most usual plan is to keep them low, but not quite so low as is done in France ; but some gardeners grow them upon trellis work. The vines produce two fruitings annually : the first, in the early part of the year, being sweet ; the second, occurring in September, being acid."

28. *Upon the Culture of the Strawberry.* By T. A. Knight, Esq., F.R.S., Pres. Read May 2. 1837.

"So much has been written upon the culture of the strawberry, and the industry of the market gardener has been so much stimulated by the high price of the fruit in the earlier part of its season, that its culture may be reasonably supposed to be scarcely capable of further improvement. The results of some experiments in which I have been engaged during the last three years have, however, led me to think that I am prepared to point out some no very trivial improvements of management.

"The gardener of the present time, in opposition to the practice of his predecessors, usually employs plants, which are afforded by the runners of the preceding year ; and such practice is perfectly successful in warm situations, and after warm and favourable seasons ; but it is important in such situations, and still more so in situations which are less favourable, to obtain plants as early as practicable in the season preceding that in which they are to produce fruit.

"Every gardener knows that plants of Keen's seedling strawberry, which have been forced early and properly in the spring, will afford, if turned out of their pots into the soil, and properly watered, a second crop in the autumn. These plants have usually a good many runners attached to them, which readily emit abundant roots, if placed in close contact with the soil and plentifully supplied with water ; and the plants which may be obtained from these runners are greatly preferable to those which cannot be obtained till a much later period. They occupy more perfectly the whole extent of the pots in which they are planted, and acquire a much greater degree of strength

and maturity during the summer and autumn than plants of inferior age; and they consequently afford more abundant and more early crops, and fruit of larger size, than is produced by younger plants.

“When I have possessed more of such plants than I have wanted for forcing, I have, early in the summer, planted them closely in contact with the base of my south walls, under the branches of my peach and nectarine trees, where the soil usually remains unemployed; and I have by these means obtained a very early and a very abundant crop of fruit of first-rate quality, which has ripened at least nine days earlier than the fruit of the same varieties in other parts of my garden. The plants of Keen’s seedling may with advantage be placed at 3 in. distance from each other, and those of the Grove End, the only other varieties, at 2 only apart.

“If such plants be suffered to remain a second year, the fruit which they will afford will be of smaller size generally, and will not ripen nearly as early; and therefore, as soon as the fruit has been gathered, and the runners, which under such circumstances are produced very early, having taken root, the old plants must be destroyed and the young, which the runners afford, made to occupy their places. The soil will, of course, require to be annually manured; and if the manure to be applied be previously incorporated with some fresh loam, the plants will be eventually benefited. If the weather be dry after planting, water should be regularly and abundantly given, as it is very important that the plants become firmly established in the soil during the early part of the summer.”

29. *Note upon Cattlèya guttata.* By John Lindley, Ph. D., F.R.S., &c.
Read April 18. 1837.

“This splendid epiphyte may be grown to great perfection in a compost of peat earth and broken potsherds in equal quantities.

30. *On the Preservation of the early Foliage of Peach and Nectarine Trees.*
By T. A. Knight, Esq., F.R.S., Pres. Read May 16. 1837.

“I stated, in a communication to this Society, two or three years ago, that my gardener had, with the intention of destroying insects, washed one whole nectarine tree, and the half of another, with water holding in suspension a small quantity of quicklime and of flowers of sulphur; and that the leaves of all my other trees of the same species had become blistered and useless, owing to the injurious effect of frost; whilst all the leaves of the one tree, and half of the other, which had been washed, totally escaped injury. I also stated, that in the following spring I had applied the same wash to all my peach and nectarine trees, and that I had been unable to find a single blistered leaf; and my gardener has recently informed me, that he has been unable to find one in the present year. How this application can have operated in any way beneficially I am wholly at a loss to conceive; but the facts appear very strong, as, during the preceding twenty-five years, by far the larger part of the early foliage of all my peach and nectarine trees, and in several seasons the whole of it, had been rendered wholly inefficient by the injurious operation of frost.

“One of my friends informed me, in the autumn of last year, that a very intelligent and successful gardener, Mr. Pearson, who has the management of the gardens of Mr. Child, of Kinlet, in Shropshire, had adopted the same mode of treatment, with the same results. I, in consequence, wrote to Mr. Pearson; and he, in answer, informed me, that in the season following that in which he had first seen my trees at Downton, he had applied the wash to all his peach and nectarine trees, except two, and that those two only produced blistered leaves, and that he had subsequently washed all his trees, and that no blistered leaves had appeared since in his garden.

“The blossoms of my peach and nectarine trees have set exceedingly well

since my trees have been treated in the manner above mentioned ; but whether this has been owing to any beneficial operation of the wash upon the blossoms, or to the more perfect maturity of the wood in consequence of the preservation of the early leaves of the preceding season, I am wholly at a loss to conjecture.

“ I applied the wash in the present season to my apricot trees ; whether, with any beneficial effects or not, I am, of course, unable to decide ; but I have a very good crop of apricots, of which few persons can, I believe, boast in the present season : it is much better than I have had in much more apparently favourable seasons. I place, however, but little confidence in the wash relatively to its operation in this case, as I am wholly incapable of conjecturing by what possible means it can operate beneficially. I am, however, much too ignorant of the laws of vegetable life to decide that it did not operate beneficially ; and as the wash banishes the red spider, the experiment appears to deserve repetition. I employed in covering my trees the same article, which I have used during many years. It consists of the slender twigs of the birch tree, which are attached to the wall, generally by being pushed in under the branches of the wall tree, and made to hang with their points downwards. These branches of the birch tree are about a yard long, and so placed that their points stand out about 18 in. from the wall ; and the quantity I employ is about as great as to afford a cover equivalent to that given by a double ordinary net. The young shoots of an elm tree, which has been shreaded two years, will afford nearly as good a covering ; and such shoots may be taken off with benefit to the elm tree. I think the covering here recommended preferable to that of a net, as that is usually employed. The expense of it is very small, and the labour trifling ; and I think that it is better calculated to intercept the heat, which radiates from the ground ; and the effects of such radiating heat are, I believe, in particular states and degrees of the temperature of the night, of no inconsiderable importance. I have, in some cases, applied the wash to my trees before covering them, and in others after ; and I think the last-named practice the best. In making the wash, I use equal parts of flowers of sulphur, of quicklime, and of soot.”

We have given this and several other communications of Mr. Knight entire, because what they contain, in our opinion at least, is of such a nature that it would evaporate under the operation of abridgment.

31. *A new Method of destroying Insects in Stoves and Green-houses.* By Mr. James Ingram. Read August 1. 1837.

“ It is gratifying to me to be enabled to inform my brother horticulturists of an effective and cheap method to destroy the red spider, scale, thrips, and green fly, without injuring the most tender plant. Where there are but few plants infested with either kind of insect, take a one-light frame and place the plants infested about 4 in. apart, and then procure from one to two gallons of green laurel leaves and well bruise them ; immediately place them between the pots and close the frame with the least possible delay, taking care to keep the frame air-tight ; at the expiration of one hour take out the plants infested with red spider and green fly, and it will be found that they cease to exist.

“ It will take from eight to twelve hours to destroy the thrips and scale ; at the expiration of that time take out the plants, place them in a warm and exposed situation, and in a few days the insects will all dry up and fall off.

“ When plants are infested in stoves or green-houses with either insect, the process must be a little varied. A house 12 feet by 20 will require about two bushels of leaves ; they can be bruised in the house, and placed in a tub or box, and covered with a sack or cloth until a sufficient quantity is bruised ; then they are to be strewed in the paths, and between the pots and other vacant places, and the house must be kept as close as possible for at least

twelve hours; the evening will be found the best time, so that the house can remain closed and covered with double mats all night. I have found by repeated trials that the plan thus described answers better than any I have ever used or heard of."

32. *Upon the economical Use of Melon Frames.* By T. A. Knight, Esq., F.R.S., Pres. Read June 6. 1837.

"It appears, at first view, a singular circumstance, that the gardens of England are least productive of good vegetables just at that season of the year when light is most abundant, and the weather generally most favourable to vegetation. In the month of June the season of asparagus expires; the potatoes of the past year are greatly deteriorated in quality; the flesh of the turnip, if that plant be grown, is hard and fibrous; and the taste of the cabbage becomes comparatively strong and unpalatable; whilst neither pea nor bean, nor early potato, nor other vegetable of much value can be brought to table, unless in very favourable situations, or raised under glass, and with the aid of artificial heat. Under these circumstances, I have thought that an account of a method of cultivating the turnip, by which that vegetable may be obtained in a very high state of perfection in the month of May and June, worth communicating; particularly as the mode of culture requires but little trouble and expense, and no new machinery.

"I caused a hotbed to be made of oak leaves in the middle of February, and when it had become warm in the end of that month, it was covered with fresh loam, manured with the ashes of burned weeds, to the depth of 8 in. In this, turnips were planted, as soon as the young plants had just unfolded their seed leaves, and for some time treated nearly as tender annual plants are usually treated: but in repeating the experiment, I should sow the seeds in the hotbed.

"Plants of any of the varieties of dwarfish early turnip may be placed with advantage in rows of 14 in. distance, and with intervals of 4 in. only between the plants in the rows. I raised at the same time an equal number of plants, in small pots of 4 in. external diameter, and 5 in. deep, to be placed between the rows above mentioned, and to be planted out in the open ground in the first week of April. At that period the frames and lights were removed, the plants having been gradually exposed to the open air and light, and another hotbed of similar form and size having been prepared, the frames and lights were put upon it. Potatoes were planted in it, which had previously been made to germinate. These remained under glass till the 20th of May, when they had acquired a large size; and they are now as mature as potatoes usually are, in favourable seasons, in the beginning of July. Upon the 20th of May, the frame was removed to another hotbed, in which I had intended to put melon plants of a month old; but owing to some seeds which I had sowed not having germinated, I have been obliged to use younger plants; and my melons consequently, which would have ripened early in July, will probably not ripen till near the end of that month.

"The turnips which remained permanently in the hotbed became fit for use in the middle of May, and have all been consumed, having proved very excellent, for any season: and those which were planted in the pots above mentioned, and removed to the open ground, are now fit for use. Some of these might probably have been placed with advantage under the shade of a north wall, but it did not occur to me to try the experiment. The mould in which all the plants above mentioned grew, and particularly that of the hotbed, was permanently kept very moist, with, I have reason to believe, very beneficial effects. A thin lining of hay, presenting the appearance of the commencement of a bird's nest, was put into each of the pots, as is always done in my garden with all plants which are to be repotted or moved within a short time. Amongst this substance the fibrous roots of the plants interweave

themselves, and they can at any time be taken out of the pots without the least danger of their losing any part of their roots or mould.

“In the management of my melon plants, I have during several past years adopted a mode of treatment which I have found very highly beneficial; and which I shall take this opportunity of describing and recommending. I use pots of about 5 in. wide and as many deep, but without any bottom. These are put to stand upon a piece of tile or slate, and are lined with hay in the manner above mentioned, the plants being always put into them as soon as the seed leaves have become unfolded. When the plants are transferred to the hotbed, the piece of tile or slate is taken away, and the pot is immersed to half its depth in the soil. Water is given to the mould in the pot, till the roots of the plant have extended themselves in the mould of the bed, but not afterwards; and the base of the stem in consequence not being ever wetted, never cankers, or becomes diseased.”

34. *On the Propagation of Trees by Cuttings in Summer.* By T. A. Knight, Esq., F.R.S., Pres. Read April 3. 1838.

“When a cutting of any deciduous tree is planted in autumn, or winter, or spring, it contains within it a portion of the true, as it has been called, or vital sap of the tree of which it once formed a part. This fluid, relatively to plants, is very closely analogous to the arterial blood of animals; and I shall therefore, to distinguish it from the watery fluid, which rises abundantly through the alburnum, call it the *arterial sap* of the tree. Cuttings of some species of trees very freely emit roots and leaves; whilst others usually produce a few leaves only, and then die; and others scarcely exhibit any signs of life: but no cutting ever possesses the power of regenerating, and adding to itself vitally, a single particle of matter, till it has acquired mature and efficient foliage. A part of the arterial sap previously in the cutting assumes an organic solid form; and the cutting in consequence necessarily becomes, to some extent, exhausted.

“Summer cuttings possess the advantage of having mature and efficient foliage, but such foliage is easily injured or destroyed, and if it be not carefully and skilfully managed, it dies. These cuttings (such as I have usually seen employed) have some mature and efficient foliage and other foliage, which is young and growing, and consequently two distinct processes are going on at the same time within them, which operate in opposition to each other. By the mature leaves, carbon, under the influence of light, is taken up from the surrounding atmosphere, and arterial sap is generated. The young and immature leaves, on the contrary, vitiate the air in which they grow by throwing off carbon; and they expend, in adding to their own bulk, that which ought to be expended in the creation of shoots. This circumstance respecting the different operations of immature and mature leaves upon the surrounding air, presented itself to the early labourers in pneumatic chemistry. Dr. Priestly noticed the discharge of oxygen gas, or dephlogisticated air (as it was then called), from mature leaves; Scheele, making, as he supposed, a similar experiment upon the young leaves of germinating beans, found these to vitiate air in which they grew. These results were then supposed to be widely at variance with each other; but subsequent experience has proved both philosophers to have been equally correct.

“I possess many young seedling trees of the *Ulmus campestris*, or *suberosa*, or *glabra*, for the widely varying characters of my seedling trees satisfy me that these three supposed species are varieties only of a single species. One of these seedling plants presented a form of growth, which induced me to wish to propagate from it. It shows a strong disposition to aspire to a very great height with a single straight stem, and with only very small lateral branches, and to be therefore calculated to afford sound timber of great length and bulk, which is peculiarly valuable, and difficult to be obtained, for the

keels of large ships ; and the original tree is growing with very great rapidity in a poor soil and cold climate.

“ The stem of this tree, near the ground, presented, in July, many very slender shoots about three inches long. These were then pulled off and reduced to about an inch in length, with a single mature leaf upon the upper end of each, and the cuttings were then planted so deeply in the soil, that the buds at the bases of the leaves were but just visible above the surface of the soil. The cuttings were then covered with bell glasses in pots, and put upon the flue of a hothouse, and subjected to a temperature of about 80°. Water was very abundantly given ; but the under surfaces of the leaves were not wetted. These were in the slightest degree faded, though they were fully exposed to the sun ; and roots were emitted in about fifteen days. I subjected a few cuttings, taken from the bearing branches of a mulberry tree, to the same mode of management, and with the same result ; and I think it extremely probable, that the different varieties of camellia, and trees of almost every species, exclusive of the fir tribe, might be propagated with perfect success and facility by the same means.

“ Evergreen trees, of some species, possess the power of ripening their fruit during winter. The common ivy, and the loquat, are well known examples of this ; and this circumstance, combined with many others, led me to infer that the leaves of such trees possess in a second year the same, or nearly the same, power as in the first. I therefore planted, about a month ago, some cuttings of the old double-blossomed white and Warratah camellia, having reduced the wood to little more than half an inch in length, and cut it off obliquely, so as to present a long surface of it ; and I reduced it further by paring it very thin, at and near to its lower extremities. The leaves continue to look perfectly fresh ; and the buds in more than one instance have produced shoots of more than an inch in length, and apparently possessing perfect health and much vigour. Water has been very abundantly given : because I conceived that the flow of arterial sap from the leaf would be so great, comparatively with the quantity of the bark and alburnum of the cuttings, as to preclude the possibility of the rotting of these.

“ The cuttings above described present, in the organisation, a considerable resemblance to seedling trees at different periods of the growth of the latter. The bud very closely resembles the plumule ; and the leaf, the cotyledon, extended into a seed leaf ; and the organ, which has been, and is, called a radicle, is certainly a caudex, and not a root. It is capable of being made to extend, in some cases, to more than two hundred times its first length, between two articulations, a power which is not possessed in any degree by the roots of trees. Whether the caudex of the cuttings of camellia, above mentioned, have emitted, or will or will not emit roots, I am not yet prepared to decide ; but I entertain very confident hopes of success.”

35. *Notes on the Cultivation of Chlidanthus fragrans.* By the Rev. F. Belfield, F.H.S., of Primley Hill, near Newton Abbot, Dorsetshire. Read September 5. 1837.

Nine middle-sized roots were put into dry earth, and placed in the hottest part of the stove in December, and kept perfectly dry, “ till the latter end of the month of March, when three roots were potted, watered, and kept in the hothouse ; of these two very shortly showed their blossom buds, but only one came to perfection, and did not seed.

“ In the end of April the six remaining roots were planted in front of the pine pit, and in the following month three of them flowered in the greatest perfection, but did not show any disposition to form a seed pod.

“ In the same border, I have another bulb, which has been growing there two years, quite unprotected in winter. This in the month of June surprised me by not only throwing up a noble flowering stem, far exceeding any of the

others, but also by perfecting its seed pod, and that without any artificial impregnation. As this may be a novelty, I have much pleasure in sending it to you; possibly its produce may be even hardier than the parent bulb.

“The border in which these plants have grown is particularly calculated for the culture of tender bulbs. *Brunsvigia Josephinae* flowered there last autumn, with a stem nearly as large as my wrist, and a head of thirty-six flowers, seeding abundantly. *Ismene calathina*, *Vallota purpurea*, and many others flower annually, *Hæmanthus toxicarius* flourishes there, but has not blossomed.”

36. *Note upon a newly introduced Half-hardy Species of Salvia called Salvia patens.* By George Bentham, Esq., Secretary.

“It will excite some surprise, that this plant, growing plentifully in the same districts from whence we have received the *S. fulgens*, should never till now have been transmitted to this country, and it will be readily believed that there are yet many which would amply reward the exertions of future collectors. We know for instance of a *Salvia longiflora* among the Peruvian mountains, with a corolla above five inches long, a *S. speciosa* in the same country with long dense spikes of a rich purple, a white-flowered *S. leucocephala*, said far to exceed the beauty of *S. leucantha*, and in the Mexican mining districts the *S. Regla*, *Sessei*, and *pubescens*, with their inflated scarlet calyxes, *S. phœnicea*, covered with a profusion of flowers of the same colour, are stated to be fully equal to the *S. fulgens* in their general appearance, and even in South Brazil it is probable that *S. persicifolia*, or some others allied to it, may fairly enter into competition with *S. splendens*. Others are known to have orange or yellow flowers of different shades. Indeed out of near two hundred species of American salvias, there seems reason to believe that three fourths of them may be worthy of cultivation.

“We may hope, however, that in the *S. patens*, we have now secured one of the most desirable of the group, more especially as there seems reason to believe that it is not more tender than *S. fulgens*. It is a perennial, growing to the height of two, three, or four feet, erect and hairy. The leaves are large, ovate, or deltoid, broadly hastate, or somewhat heart-shaped at the base, or the upper ones rounded, green and hairy on both sides. The corolla is of a rich blue, between two and three inches long, is remarkable for its broad gaping mouth; the upper lip being long, falcate, and erect, inclosing the stamens and pistil, the lower lip hanging with two lateral oblong reflexed lobes, and the middle one very broad and emarginate.

“The *S. patens* will probably thrive best under the same treatment as that which succeeds with *S. fulgens*, and like that plant it will be found to vary much in the size, the brilliancy, and the number of flowers, according to the temperature and light in which it is grown. Particular care should be taken not to weaken the plant or suffer it to become etiolated, in order that the raceme may not lengthen too much and increase the distance between the flowers.

“We owe this splendid addition to our gardens to the exertions of John Parkinson, Esq., her Majesty’s consul at Mexico, who transmitted seeds to this country early in the present year; and it was raised and first flowered in August, 1838, by Mr. W. B. Page, nurseryman, at Southampton.”

37. *Observations upon the Effects produced on Plants by the Frost which occurred in England in the Winter of 1837–8.* By John Lindley, Ph. D. F.R.S. &c. &c., Vice-Secretary. Read December 4. 1838.

“The winter of 1837–8 was in England more injurious to vegetation than any which has occurred in modern times, and it must be many years before its disastrous effects can be repaired under the most favourable circumstances. We may have had winters in which the temperature was as low, and the dura-

tion of severe weather longer, but on this occasion several concurrent circumstances contributed to mark the effects of the season more distinctly. At no previous time in the history of English gardening have there been so many rare exotics exposed to the naked influence of the climate; for the mildness of several previous winters, and the general increase of a desire to introduce new plants, had filled our gardens with species before unseen except in greenhouses.

“Not only were all the common annual vegetables cultivated in kitchen gardens entirely destroyed in the colder parts of the country, but strawberry plants prepared for forcing were so much injured as to be incapable of producing their flowers, and the vine was in many cases killed in greenhouses, in which a fire was not lighted. Among our native trees, the yew was affected in Cambridgeshire, and much more so at Glasgow; *Ruscus aculeatus* was injured in its native woods in Kent; the ivy lost its leaves and common thyme and broom were killed near London; the furze perished wholly above ground not only all round London, but even in South Wales, Cornwall and Devonshire; *Atriplex Halimus* lost its branches in Cambridgeshire; many of the hardy heaths were killed to the ground; and the common periwinkle was observed by Mr. Dillwyn to lose its leaves at Sketty in South Wales. Even at the latter place, where the climate is comparatively mild, *Menziesia polifolia* was destroyed; *Erica vagans*, with its varieties, was much injured at Woburn; and the common holly was extensively affected in several places in the middle and north of England; this plant however offered very different powers of resisting cold, some of the varieties proving much harder than others, and, according to the observations of Mr. McIntosh, those which are variegated, more so than the plain kinds. Of numerous exotic trees and shrubs from the South of Europe, New Holland, the Himalaya mountains, China, and the alpine regions of South America, many of which had been growing for years unharmed, a large proportion perished. Nearly all the rare specimens of this kind which had been collected, with so much care and cost, in the Society’s Garden, were destroyed. All round London fine old evergreen oaks, and cork trees had their leaves and young shoots turned brown, *laurustinus*, sweet bays, and the common *Arbutus* were generally cut off, while in most gardens not a plant remained alive above ground of all the beautiful varieties of the China rose and its kindred species.

“These and similar facts have induced me to investigate the extent of the mischief produced throughout the country in different situations; and by the kindness of those gentlemen to whom I applied for such evidence as came within their knowledge, I have been enabled to assemble a considerable amount of interesting information. My thanks are in particular due to—The Rev. Frederick Beadon, North Stoneham, Hampshire. Mr. William Beattie Booth, Gardener to Sir Charles Lemon, Bart. M.P., Carclew, near Penryn, Cornwall. Philip Davies Cooke, Esq., Owston, near Doncaster, Yorkshire. Lewis Weston Dillwyn, Esq., Sketty, near Swansea. Mr. James Forbes, Gardener to his Grace the Duke of Bedford, Woburn Abbey, Bedfordshire. Mr. Philip Frost, Gardener to Lady Grenville, Dropmore. The Rev. Professor Henslow, Cambridge. The Hon. and Rev. William Herbert, Spofforth, near Wetherby, Yorkshire. Mr. Stephen Hooker, Nurseryman, Brenchley, Kent. Mr. George Leslie, Gardener to John Fleming, Esq., Stoneham Park, Southampton. Mr. James Townsend Mackay, Trinity College, Dublin. Mr. Frederick Mackie, Nurseryman, Norwich. Mr. Charles McIntosh, Gardener to H. M. the King of the Belgians, Claremont. Sir Charles Miles Lambert Monck, Bart., Belsay Castle, Northumberland. Sir Oswald Mosley, Bart., Rolleston Hall, Burton upon Trent, Staffordshire. Lieut. Gen. Henry Monckton, Somerford Hall, near Wolverhampton. Mr. Stewart Murray, Curator of the Botanic Garden, Glasgow. Mr. Ninian Niven, Curator of the Glasnevin Botanic Garden, Dublin. John P. Parkin, Esq., Honorary Secretary to the Royal Horticultural Society of Cornwall. John

Rogers, Esq. Jun., Sevenoaks, Kent. The Hon. W. F. Strangways, Abbotsbury, Dorchester. John Henry Vivian, Esq. M.P., Singleton, Swansea, Glamorganshire. Joseph Walker, Esq., Calderstone, near Liverpool. William Wells, Esq., Redleaf, Tonbridge, Kent. John Williams, Esq., Pitmaston, near Worcester. Mr. John Wilson, Gardener to the Earl of Surrey, Work-sop Manor, Nottinghamshire. Mr. Robert Wilson, Gardener to his Grace the Duke of Norfolk, Arundel Castle, Sussex.

"I have also occasionally availed myself of such published accounts as have appeared most worthy of notice.

"In order that the conclusions to be drawn from the facts hereafter noticed should possess their proper value, it is necessary in the first place to explain the state of the weather, previously to the occurrence of the frost itself, and during its continuance. For this purpose the observations made in the garden of the Society by Mr. Thompson, and a few derived from other sources, will convey a sufficiently correct idea for the principal part of England.

"The month of April, 1837, was perhaps the coldest and at the same time the most sunless ever remembered. It was 7° Fahr. below the mean of the same month for ten preceding years; and the temperature of May following was 6° below the average. In the latter month, the appearance of vegetation was like what it generally presents a month earlier; the common hawthorn, for instance, was not farther advanced in leaf on the 1st of May, in the past season, than it generally is on the 1st of April. The general temperature of April and May being thus low, and the nights frequently frosty throughout both months, vegetation advanced but little, and only commenced under favourable circumstances in June; plants consequently made the greater portion of their growth after Midsummer, and during the Autumn, at which season the shortness of the days, and an unusual deficiency of sun heat, were insufficient to enable them to complete the process of lignification.

"October was nearly 2° below the average of its temperature, and consequently did not contribute its usual share towards maturing the wood of the season. November was fully 3° below the mean. December was seasonable during the first fortnight; but a most remarkable change took place after the 15th. The mean temperature of the last sixteen days of the month was 46° ; instead of the temperature which usually occurs at the winter solstice, this corresponds with that generally experienced even after the vernal equinox. The rise of temperature, above that of November, was also greater than what takes place between March and April. The thermometer was seldom below 40° at night, and never at freezing. These circumstances all contributed to bring on excitement in the fluids of plants, as was evidently manifested in the production of young shoots by many species. On Christmas day the thermometer in the shade stood at $54\frac{1}{2}^{\circ}$.

"In the beginning of January the weather was slightly rainy, and so unusually warm, that the lowest temperature observed on the 2d of the month was 41° , and for each of the four first days the thermometer marked 48° in the day, the wind blowing from the S. and S.W. On the 5th the wind shifted to the N.W. and the temperature began to fall, but up to the 7th the thermometer did not sink below 27° . After this, winter may be said to have set in; the weather continued to increase in severity till the night between the 19th and 20th, when it arrived at its greatest intensity and the thermometer sank in the morning of the 20th to $-4\frac{1}{2}^{\circ}$, the ground being scarcely covered with snow.

"In quoting the temperature throughout this paper, I have only taken the observations made upon thermometers placed under ordinary circumstances. But where the thermometer was so isolated, as to be cut off from the influence of the heat emitted by surrounding bodies, the temperature was in reality much lower, as will be seen by observing the column, in the following table, in which the observations upon the radiating thermometer are recorded. The daily register of the weather during this period was as follows:—

Days.	Temperature.		Wind.		Rain.	Radiating Therm.	Observations.
	Max.	Min.	Direction.	Force.	In. Pts.		
1	48	32	S	Little	·01	27	Fine ; slight rain.
2	48	41	S	Brisk	·02	37	Cloudy and fine.
3	48	27	S	Little	·04	22	} Very fine.
4	48	28	SW	Ditto		25	
5	34	30	NW	Ditto		29	Dense fog.
6	36	33	NE	Ditto		32	} Bleak and cold.
7	35	27	NE	Ditto		23	
8	30	22	E	Ditto		20	} Frosty, slight snow.
9	25	22	NE	Ditto		20	
10	26	13	NE	Ditto		9	} Frosty.
11	27	11	N	Ditto		5	
12	24	9	E	Ditto		0	
13	25	20	NE	Ditto		16	
14	26	4	N	Ditto		-3	Ditto with slight snow.
15	26	15	NW	Ditto		9	Frosty.
16	29	21	NE	Ditto		19	Ditto and foggy.
17	30	20	N	Ditto		18	Ditto.
18	23	19	NE	Brisk		10	Snowing.
19	22	-4½	N	Little		-12	Severe frost and clear.
20	11	7	N	Ditto		3	} Most intense frost ; therm. at 8 A. M. at zero.
21	38	28	SE	Ditto		22	
22	46	29	SE	Ditto		25	Overcast ; thawing.
23	37	24	E	Ditto		18	Fine. Hazy and cold.

" At Sevenoaks*, the following hourly and other observations, made by Mr. Rogers, are too curious to be omitted.

Friday, January 19th, 5 P. M.	-	-	12° clear.
5½	-	-	7 do.
6½	-	-	—½ becoming overcast.
7½	-	-	12 overcast.
11	-	-	3 clear.
Saturday, January 20th, 12½ A. M.	-	-	2 do.
8	-	-	3 do.

The foregoing observations were made with two self-registering thermometers, one vertical and one horizontal, laid upon a board, on a bank of snow facing N.W. One of the instruments was made by Knight of Foster Lane, the other by a different person, and both had been compared and tested accurately with a thermometer made by Newman. The register of the horizontal instrument became deranged at the 6½ P. M. observation, the spirit receding from the register, which was lodged against the bend of the tube. The remaining observations were with the vertical thermometer (Six's), checked by the mercurial side of the horizontal one; but in the observation at 12½ A. M. the mercury had passed the register of the vertical thermometer, so that an allow-

* At this place a singular phenomenon was observed by Mr. Rogers. During the extreme cold the branches of a lime-tree, which overhangs a part of his garden, drooped so as completely to lie on the ground, and those above fell proportionately; there was neither ice nor rime on them to increase their weight, so that this phenomenon must have been some direct effect of cold. The branches recovered themselves as the day advanced and grew warmer, and eventually they so completely regained their original position, that Mr. Rogers at first thought his gardener had cut away all that drooped and impeded the path the morning before.

ance of 1° is made on the two last observations for the immersion of the register in the mercury.

“In the interval between the last two observations, the mercury had descended so as to pass the upper end of the register, indicating the point it had reached by a globule, which had become detached, and which remained lodged in the bent part of the tube beyond the register, showing a temperature of at least 5° below zero; how much lower it was, there was no evidence to prove.

“At Langley Farm, near Beckenham, in Kent, the residence of Lancelot Holland, Esq., it was observed, that on the night of the 19–20th January a thermometer facing the west, 6 inches above the ground and 20 yards from the house, and from any body which could radiate heat, fell to $13\frac{1}{2}^{\circ}$ below zero. It stood at that point when Mr. Holland examined it a little after seven in the morning. It fell to zero soon after sunset; at 11 P.M. on the 19th it was 3° below that point. In the morning of the 20th, Mr. Holland examined two other thermometers attached to the house: the one facing the north was 7° , and that to the west 6° below zero.

“At Redleaf, near Tonbridge, Mr. Wells reports the cold to have been only 1° on the morning of the 20th, and the ground covered 8 inches deep with snow.

“At Cambridge, according to Professor Henslow, the thermometer was observed in the Botanic Garden at 3° above zero on the 20th at 11 P.M.; and it was, therefore, in all probability, in the morning as low as near London. Among other facts it was noticed, that *Vinca major* and *Euphorbia amygdaloides* among our native plants were much injured. Even the young shoots of all the trees in the plantations near Cambridge suffered more or less, and what seemed very remarkable, of none more so than the beech.

“In the garden of the Rev. Frederick Beadon, at North Stoneham, in Hampshire, the thermometer fell on the morning of the 20th to zero.

“At Claremont, the English seat of H. M. the King of the Belgians, Mr. M'Intosh states, that against a white wall, 4 feet from the ground, over a gravel walk, and exposed without shelter to the east, the thermometer indicated 12° below zero, and that at Walton, three miles from Claremont, it was said to be as low as -14° . The ground was not covered, at the most, with more than 6 inches of snow, and in many places was scarcely coloured. At this place it was ascertained, that on an open part of the lawn, about 50 feet above the general level of the park, the ground was frozen to the depth of 28 inches.

“In the Glasgow Botanic Garden, Mr. S. Murray states, that the lowest range of the thermometer during January and February was 1° below zero, but five miles distant from Glasgow it was $3\frac{1}{2}^{\circ}$ below zero. He however adds, that about 8 inches of snow were by a partial thaw half dissolved, and afterwards frozen so firm, that the Green of Glasgow was used as skating ground, and during this period the branches of plants were like ropes of ice—the varieties of *Rhododendron arboreum* suffered severely at that time.

“At Worksop Manor, in Nottinghamshire, the seat of the Earl of Surrey, the thermometer was seen at 3° above zero, on the morning of the 20th of January; the snow at the time lying, on an average, 6 inches deep, and covering a great part of the foliage of the evergreens. In the neighbourhood of Worksop the cold was still more severe; the thermometer having stood at Osberton, the residence of G. S. Foljambe, Esq., at 2° below zero.

“But although the frost, making all allowance for errors in instruments, was thus severe in some places, it appears, as might be expected, that it was far less intense in the western and southern parts of the island.

“At Brenchley, near Lamberhurst, in Kent, whence some returns have been furnished by Mr. Hooker, the amount of frost was not ascertained, but he states that he examined his thermometer nightly after 11 P.M., and never found it below 14° above zero. Mr. Hooker's nursery is situated on a gentle slope to the north, with a slight valley running through the middle of it from

south-west to north-east. On each side of this valley the land rises gradually, and is always inclined to be rather damp for some distance up the rising ground; in some few parts the damp extends to the highest opposite grounds. In these places the frost was most destructive.

“ At Arundel Castle, in Sussex, the residence of the Duke of Norfolk, the thermometer fell to 9° , according to Mr. Robert Wilson, but it stood for several weeks between 12° and 20° . The snow, which fell occasionally, never exceeded the depth of from 3 to 4 inches, and did not remain on the ground longer than a week or ten days. Near Worthing the temperature on the morning of the 20th was as low as 2° above zero.

“ At Carelew, in Cornwall, the seat of Sir Charles Lemon, Bart., no register of the weather was preserved, but Mr. Booth states, that as far as he recollects, the thermometer against a north wall in the garden did not fall lower than 12° above zero. The depth of frost in the ground did not exceed 7 inches. The weather, previously to the great frost, was unusually dry.

“ I have no certain return from Binstead, in the Isle of Wight, but Mr. Fleming’s gardener states, from observations made in the garden of the Rev. Augustus Hewitt, that the greatest frost occurred on the morning of January 15., when the thermometer fell to 15° ; and this agrees with a communication with which I have been favoured by Dr. Bromfield of Ryde, whose thermometer fell to 18° on the evening of the 15th of January, and never sunk lower, nor could he ascertain that it fell below 15° anywhere in that town. It is deserving of notice, that on this day the lowest temperature near London was 21° .

“ At Pitmaston, near Worcester, Mr. Williams states, that in his garden on a gravelly soil, about 40 feet above the Severn at low water mark, and a mile distant from that river, ‘the thermometer was down at 12° on the morning of the 15th, and at 13° on the morning of the 20th; those were the two coldest nights experienced. The instrument was fully exposed to the air on the east side of some paling, some few leaves of a laurel intercepting the radiation from the bulb of the thermometer to the heavens; had it been placed on the surface of the ground, and that surface had a covering of snow on it, and had the bulb of the instrument been so placed as to have radiated its caloric into space, it would doubtless have sunk many degrees lower; however, that would not have been the temperature of the air at 5 feet above the surface, but the temperature of the leaves or parts of the plant exposed to the sky.’

“ Sketty Hall, the seat of L. W. Dillwyn, Esq., is situated about three miles west of Swansea, half a mile from the sea, and only 80 or 90 feet above its level. At this place, it is believed that the thermometer never sank below 15° ; but at a gentleman’s house about 8 miles from Sketty it fell to 1° . Penllergare, the residence of Dillwyn Llewelyn, Esq., and Penrice Castle, that of C. R. M. Talbot, Esq. M.P., are both occasionally referred to by Mr. Dillwyn; the former is much higher than Sketty, more exposed, and 4 miles further inland, the latter is in nearly the same situation as Sketty.

“ From Singleton, near Swansea, Mr. Vivian states, that the lowest degree of cold experienced in that neighbourhood was on the morning of the 20th, when Fahrenheit’s thermometer stood at 15° soon after daybreak. The depth of snow at no time exceeded 2 inches, and during the severest weather there was no snow on the ground.

“ Near Liverpool, the frost was much less intense than around London; Mr. Walker states, that, in the neighbourhood of that town, gardens suffered far less than in places to the east and south, especially in Yorkshire, Derbyshire, and Nottinghamshire. Calderstone, Mr. Walker’s residence, is from 100 to 150 feet above the sea; the register thermometer did not fall below 9° on the morning of the 20th, nor could he learn that it had been lower in his vicinity. The greatest depth to which the frost penetrated the soil was found to have been from 12 to 18 inches, accordingly as the ground was covered with grass or otherwise. Very few of his extensive collection of evergreen trees and

shrubs were entirely destroyed. It was here, and elsewhere, remarked that the double *Ulex europæus* was more hardy than the wild species, and that *Ulex strictus*, the Irish furze, suffered more than either.

“ In Ireland, as is usual, the winter was much less severe; Mr. Mackay reports the lowest temperature in Trinity College Garden, Dublin, to have been only 20°. Mr. Robertson, in the Gardener’s Magazine, speaks of the cold of Kilkenny as having also been 20°, at the distance of 40 miles from the sea, and at the computed elevation of 500 feet.

“ In the Glasnevin Botanic Garden, the thermometer is stated by Mr. Niven not to have fallen below 15° above zero. In this station the dwarf fan palm (*Chamærops humilis*) has stood for two winters almost without injury.

“ It is however remarkable, that in some of the north-eastern parts of England, the cold should have been much less than about London, and in several parts of the south coast.

“ According to the observations of the Hon. and Rev. W. Herbert, at Spofforth, near Wetherby in Yorkshire, the thermometer never fell below 13° with him, or below 10° in that neighbourhood. But the cold seems in this place to have been compensated by its duration for its want of intensity. When the temperature relaxed with rain in February, although the snow melted nearly away, the rain froze for about 48 hours as it fell, and covered the whole face of the country with a sheet of ice, which was not long after buried under a fresh coat of 5 inches of snow, and it was a considerable time after the frost broke up finally, before the under coat of ice was completely thawed. Indeed, Mr. Herbert is of opinion, that the great injury to the shrubs was not occasioned by the severest night; for, when the weather relaxed for a few days, the leaves of the white *Rhododendron arboreum* were not killed, nor the wood of *R. Acklandi*; but after the snow had returned, the glass fell one night to 16°, and the great mischief was everywhere apparent the next day. ‘ If there had not been an intermediate remission of the frost, the plants would perhaps not have suffered so much.’

“ At Owston, near Doncaster, several valuable facts were noted down by Philip Davies Cooke, Esq., from plants growing in loam on a substratum of magnesian limestone; this place is situated in a low, not wet position, in lat. 53½°. Here the thermometer is reported not to have fallen below 6° above zero. Among other facts, of which use has been made elsewhere, Mr. Cooke remarks, that he found those plants suffering least, which were most sheltered from the morning sun. In a clayey loam, 2 feet in depth, on a limestone substratum, several *laurustinuses*, thus sheltered, and in a situation not affected by damp, did not suffer at all; and other specimens against walls, on which the sun never shines, were equally uninjured.

“ At Belsay Castle, in Northumberland, in the neighbourhood of which the thermometer was not remarked lower than 10° above zero, the ground was covered with snow to the depth of from 1 to 2 feet, during at least eight weeks; and consequently but little damage comparatively was experienced. For this reason the results observed in this garden are at variance with those obtained elsewhere, and the effects of the frost were much less severe than would have been expected from the northerly station of Belsay. Cauliflowers covered by hand-glasses were unharmed. A standard plant of *Spartium ætense* had only the points of its shoots scorched by the frost, but it was not in its usual health in the following summer. Camellias with a slight covering of hault, although weakened, were saved, but myrtles were killed to the ground. Among the plants, which sustained little or no injury, were *Abies Deodara*, *Pæonia Moutan*, and the following magnolias, viz. *tripetala*, *auriculata*, *glauca*, and *Thompsoniana*, as standards, and *M. conspicua*, against a wall. In a nursery ground, 500 feet above the sea, a cypress, about 20 years old, was scorched, but younger plants were mostly killed; *Araucaria Dombeyi*, and a scarlet *arbutus* were not hurt, and *Cunninghamia sinensis* was only injured in the upper branches.

“ From these places, and the other sources already named, a large number of valuable returns of plants killed, and left alive, has been obtained ; and, in order to insure all possible accuracy, they have been referred back to their several authors, for such corrections and additions as it might appear desirable to make. The result will I hope be found of great interest.

“ It is only by repeated observations of this kind that we can hope for certain success in the important object of introducing exotic species hardy enough to bear our climate ; consequently to multiply and systematize such observations is one of the most useful employments in which the horticulturist can engage. It is far more likely to lead to results of importance than attempts to acclimatize plants ; an object which has already occupied so much time to so little purpose, that I doubt whether any one case of actual acclimatization can be adduced ; that is to say, any one case of a species naturally tender having been made hardy, or even harder than it was originally. Not to mention other cases in point, *Cerasus Laurocerasus* is as tender as it was in Parkinson’s time, and yet it has been raised from seeds through many generations ; the potatoe retains its original impatience of frost, and so does the kidney bean, which last might at least have been expected to become hardier, if reiterated raising from seed in cold climates could bring about that result. The many beautiful and valuable half-hardy hybrids, lately provided for our gardens, are no exception to this statement, for they are not instances of a tender species being hardened, but of new and hardy creations obtained by the art of man from parents, of which one is hardy and the other delicate. Acclimatization, in the strict sense of the word, seems to be a chimæra.

“ What gives such evidence, as is now about to be adduced, its great value, is the well known fact, that no botanist can ever tell with precision whether a plant will support a climate to which it is unaccustomed. No one has as yet succeeded in pointing out any decided connection between the structure of plants and their powers of enduring cold, and consequently we cannot judge *à priori* what amount of cold a given plant will bear. If this could be effected, one of the most important of all steps would have been taken in the progress of horticulture, and we should be spared the loss and disappointment which now attend all extensive attempts at naturalizing exotic species. It is undoubtedly true, that particular natural orders of plants affect particular and well marked climates ; as palms, the plains of the tropics ; Cactaceæ, the temperate and dry regions of America ; and epiphytal Orchidaceæ, the hot and damp regions of all countries near the equator. But even these cases are not free from striking exceptions ; we have the fan palm (*Chamærops humilis*) growing as far north as Rome, and the wax palm (*Ceroxylon andicola*) flourishing on the mountain Quindiu, at the height of nearly 9000 feet above the sea, in bleak places where the temperature falls to 44°. Of Cactaceæ, a species of *Opuntia*, with no other protection than a hand-glass, or occasionally in the most severe weather a mat thrown over it, was able to sustain the late winter at Owston, near Doncaster, where it must have endured a temperature of 9° Fahrenheit ; *Opuntia ferox* stood unprotected at Glasgow and Dropmore ; and according to Nuttall, *Melocactus viviparus* and another are found in the elevated mountainous regions of the Missouri, where they are exposed to “intense frost.” Finally, epiphytal Orchidaceæ have been found at the elevation of 14,000 feet on the Peruvian Andes, where the cold is very considerable, in the case of *Oncidium nubigenum* ; *Dendrobium denudans* inhabits regions in the north of India, where it grows upon oaks, and is occasionally exposed to frost, according to Dr. Royle ; and Mr. Hartweg met with a species of *Lælia* (?) in the mountains of Leon in Mexico, on branches of oak trees, at an elevation of 8000 feet above the sea, where it sometimes freezes.

“ Under these circumstances, speculation as to the laws which govern such conflicting results, is in the present state of our knowledge premature, and the only useful information which can be given consists of naked facts. These facts are, however, of the utmost practical consequence, because they

enable us to judge whether it is probable, that a given species, which has been the subject of actual experiment in one climate will succeed in another or not. For this reason it has been thought advisable to go into the numerous minute details included in this report.

“The utmost which science can at present do, with reference to this subject, is to judge from probability. We know that the more nearly the climates of different countries approach each other, the greater the probability that the species peculiar to those countries may be advantageously interchanged. But although this is a valuable guiding fact for general purposes, it loses its value, or at least from the imperfection of our information appears to lose it, when we descend to particulars. Because the climate of many parts of the Himalaya mountains resembles that of England, it is probable that the plants of the former will grow in the latter country, and experience shows that this will really happen. But while such is the general fact, we continually find exceptions to it, which nothing but actual experiment could have led us to discover. For instance, the Deodar cedar appears hardy all over England, but *Abies Webbiana* suffers so much from cold, that it is doubtful whether it is likely to be of national importance in the midland and northern counties, except in very favourable situations; yet they are both from the same tracts of country, and we could not have judged beforehand that their constitution would be different. In like manner, *Benthamia* grows on the second range of the Himalaya mountains, along with *Berberis aristata*, *asiatica*, and others, and belongs to as hardy a family as they do. Yet *Benthamia* has been almost everywhere killed by the frost, except in Devonshire, Cornwall, and South Wales, and the others have as generally resisted it; and there is no apparent or theoretical difference in the nature of these plants to account for the difference. Again, if we could judge beforehand of such things, it would be said that the climate of Van Diemen's Land, especially that of the southern face of the island, would yield plants suitable to Devonshire; and such appears to be the fact with such species as *Acacia stricta* and *diffusa*, *Correa alba*, *Callistemon lanceolatus*, *Grevillea rosmarinifolia*, and some others; but, on the other hand, *Aster argophyllus*, *Pomaderris elliptica* and *Veronica decussata*, which is quite a mountain plant, were killed. No one could have suspected that this would happen; it was necessary to ascertain the fact experimentally.

“There is no doubt, that if this kind of investigation were prosecuted with sufficient care, and for a series of years, many plants not now reputed to be hardy would be added to our out-door gardens. It will be seen that *Hamelia patens*, a West Indian plant, lived for several years at Claremont; *Peganum Harmala*, a native of the hot plains of Syria, survived over last winter at Cambridge, and it will be one of the objects of another part of this paper to point out many similar cases. It is not, however, in a casual report of this description that so extensive a subject can be properly treated; all that is now proposed, is to call attention to certain facts which appear to be important.

“AUSTRALIA.

ACACIA armata and *verticillata* survived the winter of 1836-7, but were now killed at Sketty: in the spring of 1837 Mr. Dillwyn turned out some other species which had been hardened in a cold frame, but they all died except *A. affinis* and *pubescens*. *A. affinis* also survived at Glasgow; but though on a wall it was killed to the ground. At Norwich a plant of *A. dealbata* six inches in diameter at the ground was killed. In the Society's Garden every species perished, some having been growing for several years without suffering materially from winter cold. At Carclew *A. stricta* and *affinis* proved more hardy than any others, although both were slightly injured; *A. Sophora* was killed to the ground at this place in 1830-1, but had subsequently attained the height of 15 or 16 feet; after the frost the branches required to be shortened, but there was no appearance of the stem being

cracked and injured, and the plant became healthy; *A. verticillata*, which had been out for several years, and was about 15 feet high, was greatly damaged; in the course of the summer it made an effort to grow again, but ultimately died; *A. diffusa* against the front of the stove seemed unconscious of the cold; every plant of *A. lophantha* died. The latter and *A. nigricans* were killed even at Falmouth. At Kilkenny *A. longifolia*, *armata*, *lentiscifolia*, *marginata*, *decurrens*, *melanoxydon*, *dealbata* and *verticillata* were uninjured.

ANTHOCERCIS viscosa was killed in the Isle of Wight.

ASTER argophyllus, of which there was a large shrub at Carclew, had the bark split all over it; it was killed to the ground, but sprung up again. This species also died in the Isle of Wight; but in the garden of Mr. Fox, at Falmouth, where it has lived seven years, and flowers freely, it was unhurt.

BANKSIA littoralis had stood on a south wall in the Society's Garden for 2 or 3 winters, but now died. *B. oblongifolia* was killed in Mr. Fox's Falmouth garden; but *B. ericifolia*, which had grown there as a hardy shrub for 5 years, was untouched.

BEAUFORTIA decussata was killed in Mr. Fox's mild garden, at Falmouth.

BILLARDIERA longifolia, at the foot of a south wall at Glasgow, was untouched; it also appears to have borne the winter at Kilkenny and Abbotsbury without damage.

CALITRIS cupressiformis, at Carclew, was all killed except one plant, which was very much injured; the latter quite recovered.

CASSINIA rosmarinifolia was killed at Bicton.

CORREA alba, after having thriven in an open border at Sketty without any protection for six years, was killed by the winter of 1836-7, and another strong plant which was put out in the following spring also perished this winter. At Carclew, trained to the front wall of a greenhouse, the branches which projected from the wall only were killed. In the shrubbery at this place, owing to its being more stunted, the points of the shoots were all that suffered. It was quite uninjured in the open ground at Kilkenny. *C. speciosa* escaped in a conservatory at Spofforth, where *Dillwynia ericifolia* was destroyed. The species of this genus are cultivated in Mr. Fox's garden at Falmouth as hardy shrubs.

CARMICHAELIA australis, though not much injured by the winter of 1836-7, was killed to the ground at Sketty, and even, trained to a terrace wall with an eastern exposure at Carclew, it suffered severely. It also died in the Botanic Garden of Belfast.

CASUARINA equisetifolia and *stricta* were killed on a south wall in the Society's Garden; the latter had been there for 7 or 8 winters.

CALOTHAMNUS quadrifida lived in Mr. Fox's garden, at Falmouth.

CALLISTEMON lanceolatus was only damaged in the Isle of Wight; this species and some others, trained against an east wall where it flowers freely, was slightly injured at Carclew, where other kinds in the shrubbery were rusty, but the branches were unhurt; in Mr. Fox's garden, at Falmouth, it has lived for 20 years as a hardy shrub; in the Society's Garden it was killed on a south wall. *Callistemon speciosus* appears to have lived on a south wall at Kilkenny.

DORYANTHES excelsa, planted out 5 years, was killed at Bicton.

DIANELLA cœrulea was killed to the ground at Carclew, but sprang again.

DILLWYNIA ericifolia perished in a conservatory at Spofforth.

EUGENIA australis, and *Eutaxia myrtifolia*, were both killed in Mr. Fox's garden, at Falmouth.

EUCALYPTUS pulverulenta was killed at Carclew, although protected by a double covering of mats. *E. alpina*, 1½ foot high, was found alive 6 inches above the surface at Norwich, having been protected by the snow. All the species died in the Society's Garden, some of them having been fine specimens. At Kilkenny, *E. pulviger* was uninjured on a naked south wall.

GREVILLEA rosmarinifolia, an elegant shrub, proved perfectly hardy at Falmouth, and at Carclew, where it grows and flowers abundantly in the open border. *G. juniperina* was killed in the former place.

GOODIA lotifolia was killed at Sketty, though unhurt by the previous winter.

HAKEA acicularis and *linearis* lived without sustaining injury in the open ground at Kilkenny. *H. macrocarpa* was untouched upon a wall at Bicton. *H. ceratophylla*, and *H. pugioniformis*, both of which had been out for two years, were killed at Carclew.

KENNEDYA bimaculata, 16 or 17 years old, in the conservatory at Spofforth, was killed to the ground, but it sprung up again. *K. monophylla* was killed at Falmouth.

DOMATIA longifolia was cut down at Redleaf.

LEPTOSPERMUM lanigerum, against a wall, was not materially injured at Sketty. *L. ambiguum*, a beautiful shrub 8 feet high, in a sheltered situation at the corner of the garden at Carclew, was uninjured. *L. obovatum* lived without protection at Kilkenny. Several species are said to have lived against a wall at Belfast without suffering. In Mr. Fox's garden, at Falmouth, a *Leptospermum*, called *ambiguum*, has been growing for 17 years, and is 10 feet high, flowering abundantly in the summer.

MELALEUCA hypericifolia, *incana*, and *decussata*, which had been trained against a south wall at Carclew, had their bark split from the points of the branches to the root, and consequently were killed. A species of this genus is mentioned by Mr. Robertson as having been uninjured in the open ground at Kilkenny. *M. decussata*, *pubescens*, *ericifolia*, and *depressa*, survived with Mr. Fox, at Falmouth; but the *hypericifolia* was killed even there.

POMADERRIS elliptica was killed at Bicton.

SOLLYA heterophylla, although it had survived several previous winters, was killed very generally. At Carclew, in front of the stove, the old stem escaped, but the branches were destroyed; although much injured, it recovered during the summer.

TRISTANIA laurifolia was killed under a verandah at Spofforth; it was uninjured under a cold frame at Sketty.

VERONICA decussata was generally killed. At Carclew it had stood for years without injury in the shrubbery, but was killed to the ground with the exception of a few small twigs; it however lived at Falmouth.

WESTRINGIA rosmarinifolia, in the same situation as the last, was killed at Carclew.

“ CALIFORNIA AND MEXICO.

ABIES grandis, *nobilis*, and *amabilis*, all proved hardy, even in the Society's Garden.

BERBERIS dealbata, a Mexican evergreen, in the open border in the Society's Garden, was killed to the ground; but it came up again vigorously. A plant against an east wall sustained little injury.

BOUARDIA triphylla was generally killed, unless at Carclew, where it becomes an herbaceous plant, flowering late every season in the open border.

CRATÆGUS mexicana in the Society's Garden was much damaged as a standard, but only slightly on a south wall; it was uninjured as a standard at Sketty.

CEANOTHUS azureus, of which there were fine old plants on a south wall in the Society's Garden, was killed to the ground, but sprung up again. At North Stoneham it perished entirely. At Carclew the young shoots of a plant in the shrubbery were killed back to the old wood; but it recovered.

CERASUS Capollim was killed in the Society's Garden as an open standard, but was uninjured against a south wall.

DENDROMECON rigidum, a small shrub, and the only specimen in the country, was killed in the Society's Garden under a glass covering protected by mats.

PHOTINIA *arbutifolia* was killed in the Society's Garden.

RIBES *glutinosum*, *malvaceum*, and *speciosum* in the Society's Garden, were all killed to the ground, but sprung up again as if uninjured; at Sketty R. *speciosum* was damaged, but not materially.

PINUS *insignis* was generally killed, and evidently proved to be too tender for this climate. P. *Llaveana* was unhurt in the Society's Garden.

TRIGIDIA *Pavonia*, covered with leaves and planted in peat, was nearly killed at Spofforth for the first time. The bulbs in front of the greenhouse, in garden soil, though not touching the wall, were uninjured.

“ CHINA.

AZALEA *indica*. Of this species there are not many returns. With Mr. Beadon the *double purple* stood with protection, *alba*, under the same circumstances, was much cut, while *phaenicea* and the hybrid *Smithii* were killed. In the Durham Down nursery, near Bristol, all the varieties were killed except *alba*, which was unhurt. At Abbotsbury, A. *phaenicea* was damaged more than *alba*. At Redleaf, *alba*, which had been growing in the open ground for many years, was much injured. At Carlew, all the varieties seem hardy, but AZALEA *indica* itself less than the others: at this place they are grown in the shrubberies. At Spofforth A. *ind. phaenicea* was destroyed under a verandah. A. *sinensis* was killed at Dropmore, after living out for many years.

AMYGDALUS *pumila* against a north wall escaped at Claremont, but was destroyed at Glasgow.

BIGNONIA *grandiflora*, at least 30 years planted against a west wall, was killed to the ground at Claremont. This must have been one of the very first specimens of it planted out, as it was introduced only in 1800. It was not injured in the Society's Garden.

BLETIA *hyacinthina* has remained uninjured in the open border at Carlew for the last three years; and although exposed during the severe frost, it was not the least affected by it, the plant having produced several fine spikes of flowers in summer.

Chinese CHRYSANTHEMUMS; the whole collection was killed at Claremont, whether planted at the bottom of the walls, or in pots plunged in rotten tan. At Dropmore they were killed in the borders, but they survived in a south aspect under pales and walls.

CAPRIFOLIUM *longiflorum* was saved at Spofforth in a greenhouse, where calceolarias were killed.

CUNNINGHAMIA *sinensis* was little injured anywhere; at Claremont, where are the largest plants in England, stationed on a sloping rather sheltered hill side, it did not lose a leaf; but at Dropmore, a plant growing in a very exposed situation, was more damaged.

CLEMATIS *chinensis* was killed to the ground in the Horticultural Society's Garden, but sprang up again vigorously.

CYDONIA *sinensis* was damaged in the Horticultural Society's Garden on the open lawn.

FRAXINUS *lentiscifolia* was uninjured in the Society's Garden.

GLYCINE *sinensis*, although in most places untouched by the frost, had all the spurs killed back to the main branches at Redleaf, while the plant was otherwise injured.

GLEDITSCHIA *chinensis* was killed at Sketty, but the other species were uninjured.

HYDRANGEA *hortensis*. At Sketty several plants, from 20 to upwards of 30 feet in circumference, were all uninjured. At Glasgow the species was nearly killed.

ILICIAM *anisatum*, plunged in a pot behind a west wall, escaped at Claremont, while 70 species of Cape and New Holland plants beside it died.

JUNIPERUS *chinensis*; a fine specimen at Claremont, perhaps the finest in England, was not in the least hurt; nor at Belsay.

KOELREUTERIA paniculata, grown as a hardy shrubby plant, was uninjured in England; but suffered at Glasgow.

MAGNOLIA fuscata, trained to a wall, sustained no injury at Bicton; *M. punila* died there. *M. conspicua* seems to have been hardy everywhere.

An ORANGE tree, at Owston, of the variety called the Portogallo dolce, trained to the back wall of a peach-house, escaped, protected by a few fir branches and the upper lights only, with the thermometer down to 24° several times; after the lower lights were put on without fire, the outdoor thermometer fell to 10°, when the plant was injured, but it recovered. In Cornwall species of the genus *Citrus* survived the winter, with little or no protection. Mr. Fox's collection may be taken as an example of this. The *citron* has been trained for 10 years to a south wall, is 5 feet high, and produces 'fine fruit.' The *lemon*, in a south-east exposure, has lived for 17 years, is 7 feet high, and produces plenty of fruit. A plant, called the '*Citrus orange*,' lives as a hardy shrub. The *St. Michael orange* has lived 23 years on a south wall, and produces an abundance of 'choice fruit' annually. Finally, the *Mandarin Orange* has been living uninjured for three years.

PINUS sinensis, supposed to be the only one in the country, had stood out of doors 20 years at Redleaf, was 14 or 15 feet high, and was quite killed.

PITTIOSPORUM Tobira was generally killed near London. At Sketty, since 1813-14, several shrubs had remained uninjured by the frost till last winter, when they did not suffer more than some common evergreens, which grew beside them, and one of them came freely into flower. Mr. Dillwyn states, that in the scale of injury it may be placed with *Arbutus Unedo*, and that it has suffered much less than *Aristotelia Macqui*. In Cornwall this is a common shrub: several plants at Carclew were split from top to bottom, and killed; others had their last year's shoots killed; and only a few, which happened to be protected by higher shrubs, escaped. At Falmouth it did not suffer.

ROSES. Of the *Banksian* rose, both the yellow and white variety suffered severely in all the northern parts of England; at Claremont, plants 15 years old, and covering 60 or 70 yards of wall, were killed to the ground; fine old specimens perished in the Society's Garden; at Brenchley, a plant with a stem 11½ inches in circumference, and covering the whole side of a house, was entirely destroyed; they equally perished in Hampshire, but it was observed at Owston that one plant against a shaded wall escaped. The varieties of *Rosa multiflora* were destroyed. *Rosa bracteata*, the *Macartney Rose*, was killed back to its old wood, or even down to the ground. *R. microphylla* suffered in the same degree; other China roses in general were killed to the ground, or totally destroyed. The white and yellow China Rose, the sweet-scented hybrid, *Hanon*, and *Blairii*, were entirely destroyed even in Hampshire; but the latter was injured on a south wall at Dropmore. Generally speaking, the *Noisette*, *Isle de Bourbon*, and *tea-scented* varieties, were found the most tender; hybrids, between the China rose and European species, were much less affected; the beautiful *Rosa ruga*, a mule between *Rosa indica* and *arvensis*, did not suffer in the least at Pitmaston, or even at Redleaf, where the *Noisette*, and every description of *China Rose*, was killed down to the ground. It was, however, very different in Cornwall and South Wales; at Carclew, *Rosa involucrata* was the only rose that suffered, while *Rosa microphylla* close beside it was uninjured. At Sketty, *Rosa microphylla* was slightly injured, but at that place no other of a large collection was at all injured. At Penllangare *R. microphylla* against a wall was quite unhurt. *R. sinica* perished on a south wall in the Society's Garden.

PÆONIA Moutan and *papaveracea* did not suffer at all in the south of England, nor even at Claremont in various exposed situations, or Glasgow, though unprotected; but at Redleaf three dozen large plants were so much injured, that it was necessary to cut them down to the ground; and I learn from

Mr. Herbert that they were equally damaged at Ickleton, in Cambridgeshire. In some places, as at Sketty, the tree pæonies flowered better than was ever remembered.

PHOTINIA serrulata, or *Cratægus glabra*, was uninjured at Carclew, and at Singleton; but it suffered a little at Sketty, and in the midland and northern counties was either entirely destroyed or very much injured; it was observed at Dropmore, that where most sheltered it suffered most; an old plant on a south wall in the Society's Garden was nearly killed.

PODOCARPUS macrophyllus was killed at Carclew, at Redleaf, and elsewhere.

RAPHIOLEPIS indica was killed at Liverpool. It never bears even mild winters well, in the Society's Garden.

THEA viridis in a sheltered spot at Claremont escaped, but both it and *Bohea* were killed at Redleaf. *T. viridis* was uninjured at Bicton.

TAXODIUM sinense proved hardy in the Society's Garden.

“NEW ZEALAND.

CLIANTHUS puniceus was generally destroyed; at Bicton, a plant against a wall, and 9 feet high, is reported to have been killed; even in the Glasnevin garden, although protected, it died; but it lived at Binstead, in the Isle of Wight, and at Somerford, near Wolverhampton.

EDWARDSIA microphylla, of which fine specimens against walls existed in the Society's Garden, at Arundel and elsewhere, was generally killed; but at Bicton and Carclew, at the latter place in the open shrubbery, it was not at all affected. *E. grandiflora* died at Dropmore, and in the Society's Garden, where there was a very large plant, and even at Bicton; but it was undamaged at Carclew, at Belsay on the outside wall of a conservatory, and Singleton, and it survived, though much damaged, at Owston. At Sketty a standard was killed, but those against a wall were uninjured, and one of the latter at Penrice Castle, unprotected, flowered beautifully after the winter. *E. chrysophylla* was killed on a south wall in the Society's Garden, and at Bicton, but it was only killed to the old wood at Claremont.

FUCHSIA excorticata survived at Bicton; at Carclew it was killed to the ground, but shot up again.

PHORMIUM tenax was killed near London, at Cambridge, in Hampshire, and elsewhere; but at Carclew, in the shrubbery, under some large Scotch firs, and by the edge of a pond, in a kind of swamp, where its roots were under water, this plant was not in the least injured.

“WEST INDIES.

ADELIA acidoton, a Jamaica plant, was killed to the ground in the Society's Garden, but sprang up again.

HAMELIA patens, a plant of which had stood out for seven years at Claremont, was killed.

“JAPAN.

ACER palmatum perished in the Society's Garden, where unprotected; but it survived in a cold frame.

AUCUBA japonica was killed at Claremont, and other places, and much injured in some parts of the midland counties; its leaves were only discoloured in the Society's Garden, it scarcely suffered at Glasgow, and not at all at Belsay and Spofforth.

BROUSSONETIA papyrifera was but slightly injured in the Society's Garden, and proved hardy in most cases.

CLEMATIS Sieboldi and *cærulea* were generally found unhurt.

CAMELLIA japonica, though generally killed, escaped in many places without injury. This plant has stood out for 18 years at Somerford. Mr. Dillwyn reports that at Penrice Castle, a large standard, though only planted out from a conservatory the previous year, flowered after the winter. At Dropmore, a plant of the variegated variety has lived out for several years in

rather a sheltered situation. In the open shrubbery at Singleton, at Carclew, and even in the garden of Mr. Harrison, of Cheshunt, many varieties survived without injury; but they were killed, or so severely injured, as not to be worth preserving at Claremont, at Norwich, and at Owston. At Redleaf, large plants which had stood 14 years, were quite destroyed. At Spofforth, a strong plant of Middlemist's camellia, upon an upper limb of which had been inarched a branch of a double white Spofforth Seedling, stood against the wall, and the result is that not a single leaf, nor a live bud of Middlemist's camellia remains on the plant; but the limb of the white seedling is not essentially hurt, having green leaves and fresh looking buds.* At North Stoneham, the *Camellia myrtifolia*, double red, and Waratah, all out, and standards, stood well with protection. The double white, single red, striped double red, and Pomponé, against a south wall, with protection, were in no way injured.

CYDONIA japonica was uninjured in some gardens near London, but in others it was killed to the ground. At Redleaf, some of the dwarfs, as well as the large standards, were very much cut.

CHIMONANTHUS fragrans was killed at Rolleston; I have no such report from any other station.

CAPRIFOLIUM japonicum was killed to the ground at Dropmore, under a south wall, but it broke vigorously from the root after Midsummer. In the Society's Garden, it was killed in the same situation. *C. flexuosum* was also injured, but it broke again well.

DEUTZIA scabra appeared quite hardy everywhere, except at Glasgow, where it was almost killed.

ERIOBOTRYA japonica was killed almost everywhere in the midland and northern counties, although some specimens had been out many years, and even of large size, and this, whether protected or exposed, and both on north, south, and west walls; it was only slightly injured in South Wales, and escaped unhurt at Carclew; and, which is remarkable, almost without damage at Owston.

EUNYMUS japonicus was but little hurt against a wall in the Society's Garden.

KERRIA japonica was found quite safe in various situations.

NANDINA domestica lived, protected with a mat, at Abbotsbury.

SOPHORA japonica generally suffered no injury, but at Sketty it is reported to have been killed.

LIGUSTRUM lucidum was generally killed; it was however only a little hurt at Sketty, and not at all at Carclew, or in Dublin; at the latter place it has lived without injury since the year 1812.

RHUS succedaneum was killed on a south wall in the Society's Garden.

LAURUS Camphora was killed in the Isle of Wight, and in Mr. Garnier's garden at Bishopstoke, in Hampshire; but it lived at Kilkenny on a southern and protected aspect.

SALISBURIA adiantifolia sustained no damage anywhere.

“NORTH AMERICA; EXCLUDING CALIFORNIA AND MEXICO.

ASIMINA triloba stood without protection in the Society's Garden.

ANONA glabra was much injured in the Society's Garden.

* There is a great difference in the constitution of different seedling camellias; some only will bear forcing, and it appears that some can endure severer cold than others. They should, therefore, be all tried in the open ground, and it should be ascertained which is the hardiest stock to graft upon. In like manner *Rh. arboreum* should not be inarched on *ponticum* (which is tenderer than the American species, and will not swell to the bulk of *arboreum* which overgrows it), but upon the *Pennsylvania arborescens*, which grows to a very great diameter in America, when there are trees of it, which might at the lower part be sawed into planks. — *W. Herbert.*

- AZALEA. Some of the scarlet American varieties were nearly killed at Spofforth, and a small white kind also suffered severely at the same place. But *A. calendulacea* was not in the least affected.
- ARALIA *spinosa*, 10 feet high, lost the extremity of the shoots only, at Norwich.
- ARIES *Douglasii* had its leaves turned yellow at Belsay, but it does not appear to have been seriously injured. *A. Menziesii* proved hardy in the Society's Garden.
- ANDROMEDA *arborea*, and even *polifolia*, were killed in the Society's Garden. *A. floribunda* proved everywhere quite hardy, even at Worksop.
- ARBUTUS *procera* was uninjured against a west wall in the Garden of the Society; it was more injured at Carclew, where it is planted as a standard in the shrubbery; and at Brenchley, a fine plant, with a stem 14 inches in circumference, was destroyed. At Sketty it suffered very little.
- BIGNONIA *capreolata* was only a little injured on a south wall in the Society's Garden; in a similar situation at Spofforth it suffered severely.
- BERBERIS *Aquifolium*, *repens*, and *glumacea*, sustained no injury anywhere; *fascicularis* was killed at Brenchley, Woburn, Rolleston, and Redleaf, but it escaped at Singleton, and Carclew. In the Society's Garden it was killed nearly to the ground, in the open border, and much injured against a south wall.
- CLEANTHUS *americanus*, and *Cissus stans*, were killed to the ground in the Society's Garden, but shot up again. At Rolleston, the former was destroyed.
- CERASUS *caroliniana*, killed in the Society's Garden, was unhurt at Sketty.
- CERATIOLA *ericoides* sustained no injury in the Society's Garden.
- CLETHRA *alnifolia* appeared at Sketty to be much injured, but broke into leaf and flower, nearly as usual, both there and at Penllargare.
- CRATÆGUS *microcarpa* was much injured in the Society's Garden.
- CACTACEÆ. A hardy variety of *Opuntia*, under a hand-glass, occasionally covered with a mat, was found safe at Owston. *Opuntia ferox* was not at all injured at the foot of a south wall at Norwich; nor at Dropmore. At Spofforth, a Chilian species, against the front wall of a greenhouse, protected by a sloping slate, was uninjured; the same species in an open border had been killed in October.
- DIOSPYRUS *virginica* was not injured in the Society's Garden or at Sketty; at Rolleston it was injured but not killed.
- FRAXINUS *americana* and the other American species, were greatly damaged in the Society's Garden; but did not suffer at Owston.
- GARRYA *elliptica* was much injured in the Society's Garden, but at Liverpool and elsewhere it escaped.
- HALESIA *diptera* was killed in the Society's Garden. It was unhurt at Spofforth.
- ILEX *opaca* and *vomitaria* were little injured in the open lawn at Claremont, very near to where the *Common Holly* suffered; but *vomitaria* was killed at Singleton and Sketty, while *opaca*, *Perado*, *balearica*, and *prinoides*, were scarcely affected by the cold in those places; the latter, however, was cut to the ground at Glasgow.
- ILLICIUM *floridanum* survived at Claremont; it has stood out at Walton for many years, and also in the Mile End Nursery; and at Stoneham Park has lived as a grass plant for at least ten years.
- LUPINUS *arborcus* was killed in the Society's Garden, and at Sketty, though against a wall and uninjured by the winters of 1813-14 and 1836-37.
- MAGNOLIA *grandiflora* stood without injury in a great many situations, both protected and against walls; without material injury under the latter circumstances, even as far north as Doncaster; it, however, in most cases partially lost its leaves, in some cases entirely; and at Tooting, near London, a plant 25 years old was totally destroyed. At Owston, it was observed that the Exeter variety, about three feet from a wall, was uninjured, while

the common sort suffered great damage. The deciduous American species generally escaped without injury, but not everywhere. *M. glauca*, which had stood out at Spofforth for 23 years, had all its buds and small branches killed; it sustained no damage about London, where the cold was far more severe. At Glasgow, the only species which did not suffer was *M. acuminata*.

PINUS palustris was killed in several places, and much injured in others, although protected; but at Dropmore and Brenchley it was not much damaged; it was unhurt at Carclew. *P. mitis*, 15 feet high, was killed at Dropmore. *P. ponderosa* proved hardy everywhere. *P. Sabiniana* is reported safe everywhere except at Chipstead in Kent, where it was killed, and at Belsay, where it was uninjured; I should however remark, that *P. macrocarpa* and *P. Sabiniana* have been mixed in the gardens under the same name, and as the latter is reported from Rolleston to be killed, it is not improbable that it is the same plant which under the name of *Sabiniana* has suffered elsewhere. In the Society's Garden, neither were injured. *P. leiophylla* proves too tender for England.

PYRUS angustifolia was killed in the Society's Garden, and suffered much elsewhere.

PONTERERIA cordata, and *P. angustifolia*, lost the stems and leaves above water at Carclew, but the roots of both were unhurt and grew again.

QUERCUS Phellos, and its varieties, were uninjured in the Society's Garden.

RHODODENDRON. No American species suffered materially anywhere.

SIDEROXYLON lycioides was only slightly injured in the Society's Garden.

VACCINIUM ovatum, a very beautiful evergreen, was not the least affected anywhere.

SCHIZANDRA coccinea was killed in the Society's Garden on a south wall.

STYRAX grandifolium was killed in the Society's Garden, and the other species were much injured there.

YUCCA. The species generally stood in most places without any injury, even as far north as Doncaster; but at Redleaf many large plants of *YUCCA gloriosa* were cut down to the ground. At Spofforth, the species suffered capriciously; some plants being killed to the ground, and others of the same species unharmed. *Y. recurva* was not hurt, though the stem of a plant of that species, about 4 inches diameter, was destroyed near the ground at Mitcham in Surrey, in 1814. *Y. gracilis* was killed in the Society's Garden and at Liverpool; but it sustained no damage at Sketty.

VIBURNUM cassinoides was much injured in the Society's Garden.

“HIMALAYA MOUNTAINS.

ABIES Deodara is reported by every body to be quite hardy. At Worksop Manor it was not even browned so much as the Cedar of Lebanon. At Dropmore, there is a specimen inarched on the larch, and planted out for 3 years in a very exposed part of the grounds, where it is growing with great vigour. *A. Webbiana* lost its leaves at Redleaf; was, in one case, killed back to the old wood at Dropmore, otherwise uninjured; was damaged beyond recovery in the Society's Garden: one large plant at the latter place was killed outright. In Cornwall and Devon, it seems as hardy and valuable as the silver fir. The plant at Carclew has never been the least affected by cold. In the garden of the Rev. J. Garnier, at Bishopstoke, in Hampshire, there is a plant from 10 to 12 feet high, which has even produced cones. It has never been protected, and is in perfect health. Sir Oswald Mosley also reports it uninjured at Rolleston; at Belsay, *A. Morinda*, which is reported safe in other stations, was also damaged.

ACER oblongum was killed on a south wall in the Society's Garden. This species has always been found tender.

ANAGYRIS indica was killed in several places; but little injured at Claremont, against a west wall, and perfectly safe at Carclew.

- ANEMONE *vitifolia*, and several other rather tender plants of this order, were uninjured at Sketty and Spofforth.
- BENTHAMIA *fragifera* generally perished in the North ; at Belsay Castle and Woburn, it is reported as pushing from the root ; at Sketty and Penllargare, in South Wales, and at Carclew, where it is planted in the woods, and promises to be a fine underwood shrub, it only lost its leaves. It also lived at North Stoneham.
- BERBERIS *aristata*, and *asiatica*, had their leaves destroyed generally, and in some cases their new shoots, but they did not otherwise suffer. In the Society's Garden, *B. aristata* was injured in a peat bed, but not where planted in common soil.
- CLEMATIS *montana* proved hardy everywhere against walls.
- COLUTEA *nepalensis* survived everywhere.
- COTONEASTER *microphylla* was much injured, but not killed in any place ; *C. affinis* died at Norwich to within 6 inches of the graft, but was unhurt in Cornwall ; in the Society's Garden, *C. affinis*, *frigida*, *microphylla*, and *laevis*, were greatly damaged, while *C. rotundifolia*, *nummularia*, and *acuminata*, suffered comparatively little.
- DESMODIUM *nutans* was killed upon a south wall in the Society's Garden, after having survived 6 or 7 previous winters.
- EUONYMUS *echinatus*, and *sarmentosus*, were killed to the ground at Liverpool, but *E. Hamiltonianus* did not suffer at that place ; the latter was killed to the ground in the Society's Garden, but sprang up again with vigour.
- HIPPOPHAE *conferta* was uninjured at Sketty, and in the Society's Garden.
- HOVENIA *acerba*, of which a fine old plant existed on a south wall in the Society's Garden, was killed to the ground, but shot up again weakly.
- JUNIPERUS *recurva*, a beautiful species, was uninjured everywhere.
- JASMINUM *revolutum* was killed in the Society's Garden ; the plant was of large size, and had stood 8 or 10 winters ; it was scarcely injured at Owston against a wall, and not at all at Sketty. *J. Wallichianum* was cut to the ground at Spofforth and Liverpool, but in the Society's Garden, it was damaged against a south wall, and in the open border was killed to the ground. *J. heterophyllum* was killed to the ground on a south wall in the Society's Garden, but sprang up again.
- PINUS *excelsa* was uninjured everywhere. *P. longifolia* died everywhere, however much protected, except at Carclew, where it has been exposed for several years, and seems quite hardy.
- LAGERSTRÆMIA *indica*, trained to a south wall, was killed to the ground in the Society's Garden, but sprang up again.
- LEYCESTERIA *formosa* sustained no injury in the Society's Garden, and at Glasgow.
- PYRUS *variolosa* was killed at Norwich, and in the Society's Garden, in the open ground ; but not against a wall. *P. vestita* was unaffected by the cold.
- RHODODENDRON *arborescens*. The red variety was killed near London, at Sketty, at Stoneham in Hampshire, at Owston, where it had been newly planted, was nearly killed at Singleton, was untouched at Carclew. *R. arborescens album* was uninjured at Sketty, but killed at Stoneham, and destroyed to the ground at Dropmore. Of the hybrid varieties, *Smithii* and another were a little injured at Singleton, more at Woburn, Spofforth, and Norwich, and still more at Stoneham. In the Society's Garden they were all, without exception, killed to the ground, but shot up again from the root. The variety called *Nobleanum* was uninjured at Norwich. Mr. Walker found that the hybrids between *R. arborescens* and *R. catawbiense* or *caucasicum* stood well at Calderstone, so did *R. altaclerense*. Mr. John Wilson states that at Osberton in Nottinghamshire, where the thermometer fell to 2° below zero, the hybrid rhododendrons, of which there is an extensive collection, although much injured, all recovered and pushed forth new buds vigorously. In Mr. Garnier's garden, at Bishop-

stoke in Hampshire, *R. Smithii* and some others lost their leaves or became a little brown; but the Highclere hybrids stood perfectly well. With regard to the hybrids, and Indian species, Mr. Herbert's observations at Spofforth are as follows:—"My seedling RHODODENDRONS from *arboreum* by the rose-coloured *ponticum* have not lost the foreright shoots, though the leaf is damaged, answering in that respect my expectations, that they would approximate to the constitution of the hardier male. *R. altacelerense*, from *catawbiense-ponticum* by *arboreum*, is disfigured in some situations, and scarcely touched in others, but the foreright buds and flower-buds were unhurt. *R. Lindsayi* from the American *arborescens* (*maximum* var. *purpureum* of Pursh), is not much injured. A plant of it taken up to be forced, after the severest night, when the snow was melting, flowered splendidly, and its leaves were unhurt. *R. Haylocki*, from *catawbiense* by *arboreum*, has received no injury, and bids fair to flower profusely. *R. Knightii*, from the rose-coloured cinnamon leaved *arboreum* by *caucasicum*, is uninjured, and now (April 26th) in flower. *R. Acklandi*, from *altacelerense* crossed again by the scarlet *arboreum*, is killed near to the ground; those from *Haylocki*, by *arboreum*, the same. The scarlet *arboreum*, against against the front wall of the stable covered loosely with a single mat, was killed nearly to the ground, but, having been taken up in March, it sprouted from the bottom in the stove, but died soon after. The white cinnamon-leaved variety (which has stood 12 years in the middle of the garden unprotected, and formed a large, round, close-leaved bush,) is killed to the ground, and it is doubtful whether it will push up again: it measured 18 inches round close to the ground, and its principal branch was 3 inches diameter. It stood in a peaty compost, and the plant of *altacelerense* touching it is more damaged than any of the same cross. I believe that in a drier soil the cinnamon-leaved RHODODENDRON, whether white or rose-coloured, would have escaped, for another plant of the white, inarched on a *pontico-catawbiense* stock, and planted out only last summer, but growing in the natural barley soil of the garden, against a stone (east) wall, and covered with an old single mat full of holes, is quite unhurt, and shooting early, which makes it very liable to be cut by spring frosts. The mules from *R. arboreum* by the white *maximum*, and from the latter by *R. arboreum*, were not the least hurt." *R. anthopogon* died at Somerford; *R. campanulatum*, without any shelter, bore a temperature of 5° below zero at Highclere. At Spofforth, the *deciduous* *R. davuricum* was killed, the *evergreen* variety flowered more abundantly than usual.

RHEUM *Emodi* survived everywhere.

RHUS *juglandifolium* was killed to the ground in the Society's Garden, where it had been growing unprotected for several years.

RIBES *glaciale* lived in the Society's Garden; and at Abbotsbury.

SPIRÆA *argentea* lost only the points of its shoots at Brenchley, and in a very bleak situation at Redleaf. The other Nepal species all proved hardy.

STRANVESIA *glaucescens* was killed everywhere; in the Garden of the Society, on a south wall, after having flourished there for 7 or 8 years.

VIBURNUM *cotinifolium* proved hardy in the Society's Garden.

"CAPE OF GOOD HOPE."

APONOGETON *distachyon* proves at Carclew one of the most delicate as well as fragrant aquatics, and flowers all the year. During the severest weather it remained unhurt, although encrusted with ice. Seeds of it were sent by Sir C. Lemon, in a letter from Edinburgh, several years ago; they were enclosed in a bit of oiled silk, and after being received were put into a lump of clay and dropped near the edge of the pond, where they vegetated and have grown ever since.

AMARYLLIDACEOUS plants, although generally destroyed, escaped in some places; even at Claremont, AMARYLLIS *Belladonna*, *vittata*, *crocata*, *psit-*

- tacina, formosissima*, and several others, were uninjured. *CRINUM capense*, at the edge of a pond, escaped injury at Carclew, as also did *NERINE undulata* at the same station. But at Sketty they were mostly killed, and not one of them flowered in the succeeding summer. A mule Nerine, with the bulbs *above ground*, was uninjured at Spofforth.
- Of *GLADIOLUS* and *IXIA*, many species only covered with about an inch of rotten fern, survived at Claremont; *GLADIOLUS psittacinus* at Carclew. All the mule *GLADIOLI*, *SPARAXIS pendula*, which were covered with leaves, together with *WATSONIA Mariana*, and *GLADIOLUS psittacinus*, which were unprotected, were unharmed at Spofforth. Mr. Herbert considers the latter to be as hardy as a crocus, but impatient of a hot summer. But, on the other hand, at Glasgow, most kinds of Cape bulbs suffered, or perished, although in a cold frame covered with mats.
- ANOMATHECA cruenta*. A small bed of this beautiful plant was in front of the greenhouse at Carclew; it was supposed to be dead, but was left undisturbed, and again made its appearance after the winter.
- ALBUCA major* and *minor*, *EUCOMIS punctata*, *TRITONIA uaria, pumila*, and *media*, survived in a border at Claremont, protected by a thin covering of fern.
- OXALIS*, 20 species in a border, with the tuberous *PELARGONIUMS* hereafter noticed, stood well at Claremont. *O. Bowiei* was killed at Dropmore.
- CACALIA Kleinii*, an old plant, which had stood out for several years, was killed at Sketty.
- DIOSMA amœna*, trained against the front of the greenhouse at Carclew, was partly killed; the leaves were unhurt on some of the branches.
- ECHIUM giganteum* survived at Binstead, in the Isle of Wight, in high and dry situations; but it died in low grounds.
- HALLERIA lucida*, trained against the front wall of the stove at Carclew, was very little hurt; its young shoots, and those which projected from the wall, were killed, but it broke again very strong. In Mr. Fox's garden at Fal-mouth it grows freely as a shrub.
- YCIUM afrum*. This plant survived at Carclew on an east wall, while *CARMICHAELIA australis* on one side of it, and *ESCALONIA glandulosa* on the other, were hurt.
- MYRSINE africana*, which had stood 23 years against the front wall of the stables at Spofforth, having been planted out in 1815, was as much injured as it was when the glass fell to 10° many years ago, but it was not killed; one branch, however, alone remained with green leaves, and the rest were dead.
- MESEMBRYANTHEMUMS*, which usually survive the Cornish winters, and flower freely during summer, were all killed at Carclew.
- OLEA fragrans* was killed against a south wall at Norwich; slightly injured at Carclew.
- ORNITHOGALUM caudatum*, with the bulb above ground, was injured, but survived at Spofforth.
- PELARGONIUM flavum, triste, lobatum*, had been planted at Claremont in a warm border for seven years, and all survived unhurt, though only covered with rotten fern to the depth of an inch, or thereabouts; there were also several other tuberous rooted species uninjured. Mr. M'Intosh finds, that planting out is the best way to grow all this tribe, as well as most bulbs, which are not evergreen, or retain their leaves. *P. triste* lived unprotected at Abbotsbury. A large plant of the ivy-leaved pelargonium, 16 or 17 years old, was killed in a conservatory at Spofforth.
- RICHARDIA africana*, or *Calla æthiopica*, with its stem two inches deep in the pond, was killed at Sketty, though it received no material injury from the preceding winter. At Cheshunt, Mr. Harrison has had two large plants in a pond for nine years, without either care or protection; they bloom every year, and were not in the least affected by this frost. The plant proved equally hardy at Carclew, both at the edge of a pond, and in the open border.

TRITOMA media was killed at Spofforth ; *T. Burchelliana* was unhurt.

TEUCRIUM fruticans. This pretty free flowering evergreen shrub, nailed to the front of the greenhouse at Carlew, was only killed back to the old wood.

ERICA. Of all the Cape species, which had been turned out in the open ground, the only species which are returned as having survived, at Carlew, are *E. concinna* and *gracilis*, where they were protected by a covering of mats. At Falmouth, in Mr. Fox's garden, *E. verticillata*, *colorans*, *gracilis*, *baccans*. and *favoidea* were killed, but *E. flammea*, *tubiflora*, *lævis* and *abietina* stood the frost.

ERIOCEPHALUS africanus, *MURALTIA mixta*, *CEDERA prolifera*, *POLYGALA latifolia*, *myrtifolia*, *grandiflora*, *speciosa*, *PSORALEA pinnata*, and *STRUTHIOLA erecta*, all died in Mr. Fox's Falmouth garden.

ARCTOTIS aureola and *maculata*, *BRUNIA ericoides*, *GAZANIA rigens*, *GNIDIA simplex* and *flava*, *HERMANNIA plicata*, *hirsuta* and *flammea*, *LEONOTIS Leonurus*, *MELIANTHUS major*, *PENTZIA flabelliformis*, *PLUMBAGO capensis*, *SALVIA aurea*, *SPARMANNIA africana*, *STRUTHIOLA ovata*, all lived without injury at Falmouth, in Mr. Fox's garden.

SOUTH OF EUROPE, LEVANT, AND NORTH OF AFRICA,
WITH ADJACENT ISLANDS.

AMYGDALUS orientalis was killed in the Garden of the Society, but escaped at Cambridge.

ARISTOLOCHIA sempervirens was uninjured at Cambridge.

ARBUTUS Unedo. This tree was affected very differently in different places ; in the warm gardens in the midland counties, especially about London, it was either destroyed, or nearly so, but at Owston, and elsewhere in the north, and at Sevenoaks, where the cold was particularly intense, it was uninjured ; at Sketty, every plant which was exposed to the east, suffered severely, and many were killed ; at Claremont, trees 25 feet high and 2 feet in circumference, were entirely destroyed. In the Society's Garden every specimen perished, either wholly, or as far as the ground, but a hybrid variety between this species and *A. Andrachne* escaped unhurt, both in the latter place, at North Stoneham, and at Sketty. *A. Andrachne* was killed in the midland and northern counties, but not in the southern ; at Dropmore, a plant growing against a south wall, was found quite dead ; but Mr. Forbes reports from Woburn, that his plant is only injured at the extremity of the young shoots. In the Society's Garden, and at Owston, this species, would not have died had not the stock of *Arbutus Unedo*, upon which it was grafted, been killed.

ASPARAGUS scandens was killed to the ground in the Garden of the Society, but pushed up again vigorously.

ATRIPLEX portulacoides, a British plant, was killed in the Society's Garden.

BUXUS balearica was uninjured at Sketty, at Penllangare, at Owston, and about London.

BUMELIA tenax was killed in the Society's Garden ; but not injured at Abbotsbury.

BUPLEURUM fruticosum was scarcely affected near London, and to the south, but at Cambridge it was killed, and it is well known to be a tender plant in the midland counties. At Owston it was much injured.

CISTUSES were killed in almost all places, with the exception of the *gum cistus*, which occasionally escaped ; in the Society's Garden, the whole collection, among which were many plants 8 or 10 years old, were destroyed. *C. laurifolius* was uninjured at Spofforth ; at Singleton, Mr. Vivian lost all but *laurifolius* and *corboriensis* ; at Sketty, *laurifolius* was the only species that remained entirely unhurt, and next to that species *corboriensis* was least injured ; at Abbotsbury *C. salvifolius* and *purpureus* perished, but *C. villosus*, *laurifolius*, *cyprius*, and *creticus* were uninjured ; in Norfolk, in Hampshire, in Kent, and the neighbouring counties, the collections of this genus were almost annihilated.

- CELTIS *orientalis* was killed on a south wall in the Society's Garden, where it had lived many years.
- CLETHRA *arborescens* had stood for several years in the shrubbery at Carclew, but was very much injured this year.
- CLEMATIS *cirrhosa* was killed on an east wall in the Society's Garden.
- CERCIS *Siliquastrum* was uninjured, or very little affected, anywhere.
- CYTISUS *æolicus*, and *Weldenii*, lived at Abbotsbury; but the former was a little hurt.
- CERATONIA *Siliqua* was uninjured at Owston, in a cold peach house, with only the upper lights till the middle of January; the leaflets and shoots of last year were killed at Carclew.
- CIENOPODIUM *fruticosum*, a British species, was killed to the ground at Cambridge, and near London.
- CONVOLVULUS *althæoides*, and *bryoniaefolius*, were uninjured at Cambridge. *Cneorum* stood without damage at Abbotsbury.
- CUPRESSUS *sempervirens*, which was generally killed about London, was not affected at Owston. At Belsay, young plants were mostly killed, but two old ones, 16 or 18 feet high, escaped. *C. lusitanica* was also killed in most places, except Cornwall and Devonshire.
- CNEORUM *triccoccum* died at Cambridge.
- CHAMEROPS *humilis* survived the winter in the Glasnevin Garden, but was killed in that of the Society.
- CYNARA *horrida* was killed at Cambridge, together with *C. Scolymus*, the common artichoke, which was lost in almost all the gardens in the midland and northern counties, if unprotected by litter.
- DIANTHUS. The *Samian tree pink*, which had remained at Spofforth since it was raised from seed, about 20 years ago, in a pot of pure sand in the most exposed corner of the greenhouse, touching the front and side glass, was killed.
- CORONILLA *glauca*, which survives the winters readily in Cornwall and South Wales, where it is cultivated as a common border shrub, and flowers abundantly during the winter months, was either destroyed, or very much injured. It perished at Spofforth under a verandah.
- DORYCNium *hirsutum* perished in the Society's Garden.
- DAPHNE *Laureola*, a British plant, was much injured in the Society's Garden, *Cneorum* suffered a little; all the others died. But *D. pontica* sustained no damage at Liverpool, or Spofforth; although it was damaged at Dropmore. At Sketty and Penllargare none of the species were at all affected. *D. australis* stood at Abbotsbury.
- DIOSPYRUS *Lotus* was much injured in the Society's Garden.
- EUPHORBIA *mellifera* proved quite hardy, and untouched, at Carclew. *E. pithyusa*, *veneta*, and *rigida*, lived at Abbotsbury.
- ERICA. The collections of hardy *heaths* suffered great loss. After the frost of the 20th, the bushes were found shivered to pieces, as if they had received a discharge of small shot; excepting in the south, they were either destroyed or killed to the ground; even *E. vagans*, the *Cornish heath*, must be included in this list. *E. australis*, however, suffered but little at Brenchley, and stood undamaged at Carclew, Abbotsbury, and Liverpool, but it perished in most other places. Large bushes of *E. mediterranea*, in the shrubbery at Calderstone, were very much broken and disfigured by the snow, but none of them were killed. At Sketty, large plants of *mediterranea* in exposed situations suffered greatly, but *stricta* escaped without material damage. *E. arborescens* was killed to the ground at Woburn, but remained unhurt at Abbotsbury, Penrice, Penllargare, and some other places in the neighbourhood. *E. scoparia* escaped at Spofforth, and *umbellata* at Abbotsbury.
- FIGS, unless against walls, were killed to the ground in all the midland and northern counties, but experienced no injury in Devon and Cornwall. Plants, 10 or 12 years old, were killed to the ground at Belsay, in the same situation with a plant of the scarlet variety of *Arbutus Unedo*, which was

- unhurt. At Arundel, two varieties of figs are cultivated as open standards, the effects upon which by frost was very remarkable. The green Ischia, which is that principally cultivated, was so slightly injured that the trees produced an average crop of fruit last autumn. One tree of this variety is of the following unusual size; height $26\frac{1}{2}$ feet, branches $34\frac{1}{2}$ feet in extent, girth of stem at the surface 9 feet, where it divides into three, each measuring in circumference 2 feet 9 inches. The other, a purple variety, growing under exactly the same circumstances, was so severely damaged that almost all the trees of it were cut down; they again pushed forth shoots, but none produced anything like a crop of fruit.
- FONTANESIA phillyreoides** was killed down to the ground in the Society's Garden, and hardly recovered.
- GENISTA triquetra**, which had stood 20 years at Spofforth, was killed; it was much injured in the Society's Garden, as well as most of the other species. At Dropmore, the plants growing in the woods among heath were little injured, while others in pots covered with mats were killed. At Belsay Castle they did not sustain any injury.
- HABLITZIA lamoides** was killed to the ground at Glasgow, but afterwards quite recovered.
- HIBISCUS syriacus** suffered severely in the Society's Garden; but not at Owston.
- HYPERICUM hircinum** was killed to the ground at Cambridge.
- ILEX balearica** was not in the least hurt about London.
- JASMINUM officinale**, trained to a south wall, and of many years' growth, was killed to the ground in St. James's Square, in London, and at Dropmore under a south wall; but it was unhurt at Spofforth. Both it, *J. fruticans*, and *humile*, shared the same fate in the Society's Garden. But none of these three species received any injury at Sketty.
- JUNIPERUS macrocarpa** was killed at Sketty, and another species materially injured; *phœnicea* had been killed by the preceding winter; *lycia* was damaged in the Society's Garden, but *oxycedrus* was unharmed there.
- LAVANDULA Spica** was killed in the Society's Garden.
- LAURUSTINUSES**, in those places where the cold was very severe, were found to suffer in proportion to the shelter they experienced; in the warm gardens about London, and in other protected situations, they were generally destroyed; but at Owston they escaped in shaded situations against walls; and at Claremont, Mr. M'Intosh reports, that they were killed to the surface, except where they were stunted, and growing in cold late situations, not influenced by the sun. At Sketty, where the winter was comparatively mild, some of these plants in eastern exposures were injured, and others, in sheltered situations, continued to flower unhurt. At Hitcham in Suffolk they were little injured.
- LAURELS.** As is usual, the *common laurel* suffered more than the *Portugal*, and in some low situations was completely killed to the ground, but neither appear to have materially suffered anywhere; at Sketty, they were both observed to have lost their leaves to a far greater extent than was ever before seen. Upon the subject of the *common laurel*, Mr. M'Intosh observes, that in some parts of the ground at Claremont, whole banks of them were killed to the surface, whilst others hardly lost a leaf; this he observed on dry sheltered banks, as well as in more exposed places, and even by the banks of ponds, and where they all appeared alike healthy; wherever a current of air existed, they suffered most; those planted (perhaps to the number of 10,000) in autumn, stood as follows, viz. those planted in September and beginning of October, which had begun to grow, were very much cut up, those planted from the beginning of November to Christmas nearly escaped. Some trees, 25 feet high and 6 or 8 inches in diameter, that had come into bud in December, were quite killed. Both kinds of laurel were uninjured at Spofforth, notwithstanding the dampness of the situation, which is not congenial to them.

LAURUS nobilis was generally killed about London. At Claremont, trees 25 feet high were all destroyed to the surface of the ground, or entirely. But at Dropmore, a large plant 20 feet high, with branches spreading 15 feet horizontally, which was to all appearance quite dead in the early part of summer, produced young shoots very near the top, and seems likely to recover in the course of next season. Professor Henslow mentions a fine plant in a garden at Ely having sustained very little injury; and even at Cambridge, although plants were damaged, the mischief was not serious. At Spofforth, some branches were killed, some not. At Sketty, the leaves were less injured than those of the common laurel; this species flourishes remarkably in that neighbourhood; Mr. Dillwyn mentions a noble specimen of it, in the garden at Margam, (a mansion of Mr. Talbot's, near the sea, about 14 miles distant from Sketty,) which, on being accurately measured about two years ago, was found to be 61 feet 6 inches high; but it was considerably injured by this winter.

LINUM flavum, against a south wall, was not injured at Norwich, nor at Spofforth in the open border. Of *L. tauricum*, grown upon a rock at Dropmore, some survived, but others were killed.

MELIA Azedarach was injured at Owston, but not severely.

MEDICAGO arborea was killed both at London and Sketty, though in a very sheltered spot in the latter place.

MORUS alba, and its varieties, were much damaged in the Society's Garden.

MYRTUS communis, which survives the winter without difficulty about London, perished this year; it was much disfigured at Carclew, and destroyed in most other places, but Mr. Dillwyn observed, that the broad leaved variety, in no part of his grounds, was more injured than some of the common evergreens which grew by its side, and till last winter it had hardly suffered at all since the winter of 1813-14; the small leaved variety, which never appeared to be equally hardy, was, however, killed, or nearly so. At Owston, all the bushes were killed down, but shot up again.

NERIUM Oleander. Of two plants, which had thriven without protection since 1834, one was killed by the winter of 1836-7, and the other last winter, at Sketty.

OLIVE. Of the common cultivated kind, almost every specimen was killed to the ground, or more frequently wholly destroyed, in England; even in the warm garden of Abbotsbury, in Dorsetshire, this occurred, but in the Garden of the Society, a hardy variety, obtained from Nikita in the Crimea, through the good offices of Mr. Buckatzsch of Guben, sustained no injury. *Olea europæa* var. *buxifolia* is also reported by Mr. Dillwyn to have survived without protection at Penrice Castle, without having been injured.

NARCISSUS (*Corbularia*) *serotinus*, in a dry border at Spofforth, had pushed its leaves before the frost, and they remained unburt; none of the species belonging to the *Daffodil* section were touched; but those of the *Hermione* section, from Italy and Malta, suffered very much.

PALIURUS aculeatus had its branches much injured at Cambridge, but is not mentioned in any other of the reports as having suffered; except at Glasgow.

PHILLYREAS. Of the species of this genus, the *oleifolia*, *rosmarinifolia*, and other entire leaved species, proved most delicate; the serrated kinds lived as far north as Owston. At Claremont, *P. latifolia* hardly suffered at all, and, in the Society's Garden, this species and *P. obliqua* proved perfectly hardy.

PINUS. The only European species of this genus which sustained any injury, was *P. halepensis*; in the Society's Garden, a fine old specimen 15 feet high, originally presented to the collection by Sir Charles Monck, Bart., was entirely destroyed; but at Belsay Castle, this species, in a high and dry situation, was not injured. *P. brutia*, a species very near *P. halepensis*, stood without protection in the Society's Garden. At Dropmore, *P. canariensis* was much injured, but its trunk and old branches were saved,

- owing, as it is supposed, to the great thickness of the bark, and a covering of fern sufficient to keep off 20° of frost.
- PTEROCARYA caucasica**, commonly called *Juglans fraxinifolia*, in the possession of Mr. Dillwyn, was uninjured; and at Woburn, although in an exposed situation, it did not suffer.
- PISTACIA Terebinthus** had only the ends of the shoots killed at Norwich, and an old tree in the Apothecaries' Garden at Chelsea, was scarcely injured. Neither did it suffer at Owston. *P. narbonensis* was killed to the ground in the Society's Garden. At Abbotsbury, *P. vera* and *Terebinthus* were unharmed, but *P. Lentiscus* died.
- PHLOMIS fruticosa**, and *ferruginea*, perished in the Society's Garden, at Glasgow. The former was uninjured at Sketty.
- PEGANUM Harmala** survived at Cambridge.
- PUNICA Granatum** was severely cut in the Society's Garden, on south walls, and *P. nana* was killed: but the former suffered little in many other places.
- QUERCUS coccifera** was killed at Redleaf and elsewhere near London, but not at Owston, nor Rolleston.
- RIHAMNUS Alaternus** and all the varieties suffered severely near London, more than Phillyreas; none were injured at Owston, or Sketty. *R. balearica* escaped at Cambridge.
- RUSCUS racemosus** suffered little in bleak places near London. *R. androgynus* escaped at Cambridge.
- RUTA graveolens** was killed to the ground at Claremont and Dropmore, but not injured in several places near London; it was almost destroyed at Glasgow.
- SANTOLINA Chamæ-cyparissus** had its branches slightly injured at Cambridge.
- SALIX babylonica** was not at all injured at Claremont, or near London, although killed at Glasgow, as it often is in Scotland in less severe winters.
- SALVIA officinalis** was killed in many places about London, and much injured elsewhere; it all died at Penllargare, but escaped unhurt at Sketty.
- SPARTIUM multiflorum**, *acutifolium*, and *radiatum*, were entirely killed in the Society's Garden. At Belsay is a plant of *SPARTIUM ætense*, 5 feet high; it was only a little weakened by the winter; it grew from a single seed, gathered by Sir C. Monck, on Ætna, in 1831; it is highly ornamental in August and September, and may be called generally hardy in England. *Sp. patens* was killed at Spofforth, and *junceum* was cut to the ground. *S. infestum* perished at Abbotsbury.
- TAMARIX gallica** was killed to the ground in Middlesex, and to the north, in some places, but not at Owston. *T. afra*, and *Libanotis*, were uninjured at Abbotsbury.
- VACCINIUM madeiense**, which was cultivated at Claremont for its fruit, was killed. *V. Arcostaphylos* was much injured in the Garden of the Society.

“ CHILLI, AND SIMILAR SOUTH AMERICAN REGIONS.

- ALSTRØMERIAS** sustained the cold in the open border surprisingly well. *A. pulchella* lived in an open border in the Garden of the Society without injury. *A. psittacina* was saved in a south border at Norwich. *A. Peleriniana*, *pulchella*, *ovata*, *hirtella*, *aurea*, and one or two others, were uninjured at the bottom of a wall at Claremont. Mr. Herbert reports, that at Spofforth the Alstrømerias are all very flourishing; a large bed of seedling plants of *aurea*, covered with sawdust, began to show green sprouts in March, and even a single plant of the Valparaiso variety, which might have been supposed to be tenderer than the former from Chiloe, covered only with a handful of sawdust, pushed at the same time.
- ALOYSIA citriodora** was killed to the surface of the ground in the midland counties, but in the south of England only deprived of the young wood. Several plants had remained for years uninjured at Sketty, but they were affected in the winter of 1836-37, and were totally destroyed in the present

winter. A plant, however, against a wall at Penrice Castle sustained no material injury.

ARAUCARIA *Dombeyi* (*A. imbricata* of the Gardens) was but little injured anywhere in the midland counties. At Kew, where it was protected, at Dropmore, and Redleaf, it was but slightly affected; in the Society's Garden, unprotected, the bottom branches were killed, but it was not hurt materially. Mr. Gowen has furnished me with the following fact, concerning this interesting species:—'There are three Araucarias planted out at Highclere, and each about a foot high. They are all nearly upon the same level in the pleasure ground, which is a plateau of thin soil upon a substratum of hard chalk, on which is overlaid a bed of plastic clay, more or less thick. The height of the plateau is about 600 feet above the level of the sea, lying to the north of a very extensive and elevated tract of chalk downs; the climate is cold, and the winter atmosphere damp and foggy, and extremely liable to wind. Two of these plants are in open spaces in a large grove of lofty trees, and, of course, sheltered from wind. These suffered last winter, having had their foliage much injured. The third is on the open lawn, unsheltered and exposed to every wind that blows. This plant did not sustain any injury from cold, although the thermometer in its vicinity was down to 5° below zero. It may here be worthy of remark, that the thermometer was suspended in a bush of *Rhododendron campanulatum* within the grove above alluded to. Not a leaf or bud of the *rhododendron* was injured, and it flowered beautifully in the early spring. It is obvious that the *Araucaria Dombeyi* is perfectly hardy, but it is impatient of damp, prefers an open situation, and is liable to have its foliage injured by moisture.' At Belsay, unprotected, it was not injured in even a single leaf; at this place it is 7 or 8 feet high, and still retains on its stem, at the surface of the ground, the leaves which it had when a small plant. *A. brasiliensis* was destroyed almost everywhere; at Dropmore, it was protected by a thick covering, and at Woburn, with double boards, and a lining 3 feet thick of fern: at the former place it afterwards formed buds within four inches of the ground.

ARISTOTELIA *Macqui*, a plant which had survived many winters in most parts of England, was generally killed; but at Carclew, although it had been killed to the ground in the winter of 1830–31, it sustained but little damage this season.

AZARA *dentata* was killed on a south wall in the Society's Garden.

BERBERIS *empetrifolia*, and *dulcis*, proved hardy near London, and elsewhere; even in Nottinghamshire. In some cases they were cut to the ground, but they sprang up again freely.

BOUSSINGAULTIA *baselloides* was observed by Mr. Niven, in the Glasnevin Garden, to have remarkably hardy roots. They were exposed near the surface of the ground without any covering, and pushed again vigorously after the frost.

BRUGMANSIA. Neither species appears to have stood anywhere, except in Mr. Fox's warm garden at Falmouth.

CALCEOLARIA. Some hundreds of shrubby varieties, which had stood at Claremont in the open borders from 4 to 5 years, were not only killed, but the best shrubby sorts, in a brick pit covered with a glass (but no mat), were also destroyed. *C. viscosissima* and *integrifolia angustifolia* were killed in the Society's Garden. At Spofforth, several survived; *C. integrifolia*, and *sessilis*, were destroyed at this place in a conservatory, but *C. viscosa* survived in the same situation. *C. rugosa* and *integrifolia* were killed even at Falmouth, after having grown without protection for five or six years.

CESTRUM *Parqui* was killed at Sketty, and in the Society's Garden, along with *C. nocturnum*.

CULIDANTHUS *fragrans* escaped, in a hothouse border, at Glasgow.

COLLETIA *Ephedra* survived at Liverpool. In the Society's Garden, the only species which escaped was *C. horrida*, and that was not much damaged. At Belsay, *C. serratifolia* was only killed to the ground.

- CYPELLA *Herbertiana*, covered with a few leaves, was uninjured at Spofforth.
- DURANTA *cyanca* was killed in the Society's Garden, after surviving three or four winters.
- DUVAUAS. The various species were in some places killed entirely; at Carclew, the main stem of one species only was safe. In the Society's Garden, *D. latifolia* was destroyed on a south wall, *D. dentata*, and *dependens*, were cut to the ground, but *D. ovata* was unharmed.
- ECCREMOCARPUS *scaber* was generally killed. At Carclew, in a border where it was trained over a low coping, and along the front of a terrace-wall, facing the east, it was killed; while at the distance of only a few feet, where it was trained against the trellis of a bastion, in a dry situation, it remained alive and vigorous.
- EHRETIA *serrata* has been growing several years in the Society's Garden. This winter it was killed to the ground on a south wall, but sprang up again.
- ERYTHRINA *Crista-galli* survived at Cambridge; and at Claremont, and Dropmore, at the bottom of a wall, in front of a stove; but at the latter place others perished at the foot of a greenhouse.
- ESCALLONIA *rubra* was killed in Hampshire, with protection; elsewhere injured, but not destroyed. At Carclew, and in South Wales, but slightly injured. *E. montivedensis* was generally killed. *E. glandulosa* was found at Singleton to be the hardiest of the genus. In the Society's Garden, it and *E. rubra* were killed to the ground, but sprang up again vigorously; all the rest perished.
- EUXENIA *Mitiqui*, after living many years on a south wall, was killed in the Society's Garden.
- FUCHSIAS. Where these were a little protected, although killed to the ground, they generally sprang up again from the root; in South Wales they were but slightly injured. At Carclew, all were killed down to the ground, except *F. gracilis* and *virgata*. *F. discolor* alone survived at Glasgow, and this kind proved the most hardy in the Society's Garden.
- HEIMIA *salicifolia* was cut to the ground at Spofforth, but not killed. At Falmouth it was uninjured.
- JABOROSA *integrifolia*, which for several years had covered a yard square of a hothouse border, was entirely destroyed at Glasgow.
- KAGENECKIA *cratægifolia* was killed on a south wall in the Society's Garden.
- LIMNOCHARIS *Humboldtii*, which had lived in the pond at Sketty, through the winter of 1836-37, and which flowered beautifully, was killed.
- LITHREA *caustica* perished on a south wall in the Society's Garden.
- LOBELIA *Tupa* was generally saved; it was, however, killed at Spofforth, where it had lived many years.
- MAYTENUS *chilensis* was killed on a south wall in the Society's Garden, after having stood 8 or 10 winters.
- NICOTIANA *glauca* was killed on a south wall in the Society's Garden.
- PASSIFLORA *cærulea* stood badly. In the Society's Garden, and many other places, it was killed entirely; at Owston, and Singleton, it was cut down to within a few feet of the ground; at Sketty, it was not materially injured. *P. cæruleo-racemosa*, *palmata*, and *adiantifolia*, were killed at Carclew.
- PERNETTIA *mucronata* was killed in the Society's Garden; but it, and *pilosa*, lived at Somerford and Birmingham; and another species, from Valdivia, is reported to have survived in the Botanic Garden of the latter town.
- PHYSIANTHUS *albens* was killed at Cambridge; to the ground at Liverpool; and was unhurt at Glasnevin.
- PORLIERIA *hygrometrica* was killed, under a verandah, at Spofforth.
- PROSOPIS *siliquastrum*, PSORALEA *glandulosa*, old plants on a south wall, perished in the Society's Garden.
- PSIDIUM *Cattleianum*, trained against the front wall of the stove, and protected by a mat, lived at Carclew; some of its leaves became rusty, like those

of the myrtle, but the branches generally budded vigorously, and in the summer the plant was as healthy as ever.

QUADRIA heterophylla, in a very sheltered situation at Carelew, was much hurt, but afterwards recovered.

SALIX Humboldtiana was killed in the Society's Garden.

SOLANUM crispum, against a west wall, was killed to within 2 feet of the surface, at Norwich; in the Society's Garden, it was destroyed on a south wall.

SPHACELE campanulata was killed on a south wall in the Society's Garden.

VESTIA lyciodes was killed at Woburn and Norwich; in other places, including Cornwall, killed down to the ground.

VERBENA Melindres lived in open ground at Arundel Castle, protected with a covering 6 inches deep of leaves.

VOLKAMERIA inermis was killed to the ground in the Society's Garden, but sprang up again with rather strong shoots.

ZEPHYRANTHES candida sustained no injury at Spofforth, even in the leaves; but it was killed at Dropmore.

“The results of these returns, and of the numerous observations made in the Garden of the Society, are less conflicting than they usually are in such inquiries. The effects of cold are so much modified by soil, by the surrounding atmosphere, by a variety of local causes which are often not appreciable, that perfect uniformity in apparent results cannot be expected. This has long since been observed by Humboldt and other writers upon Botanical Geography, in comparing one country with another; it has been found that parallels of latitude offer by no means an indication of uniform temperature, as they would do, if the globe were a sphere with a perfectly level surface, and a homogeneous crust, but that the mean temperature of some countries, Lapland for instance, is much higher than it should be, from their position with regard to the equator. Such being the case with respect to large tracts of land, it *à fortiori* would be expected in different localities on such an island as Great Britain, with its diversity of coast, wood, mountains, and exposure to the ocean: accordingly we find in the garden of Mr. Fox, at Grove Hill, near Falmouth, not only that such common green-house plants, as *Acacia armata*, and *longifolia*, *Brugmansia suaveolens*, *Calothamnus quadrifida*, and several Cape heaths, survived last winter, although they perished in other places in Cornwall; but that the much more tender species, *Dracæna fragrans*, *Justicia Adhatoda*, *Thunbergia coccinea*, which are generally regarded as stove plants, were also uninjured. In this garden, *Acacia armata* has been growing 16 years, *Aloysia citriodora* 24, the red *Camellia japonica* 25, *Jasminum revolutum* 15, *Leptospermum ambiguum* 17, *Callistemon lanceolatus* 20, and the Cape plants, *Pentzia flabelliformis*, and *Salvia aurea*, from 14 to 15 years, without being killed. This fact is unparalleled in the records of British gardens, even in the case of that of Mrs. Hamilton Nesbitt, in East Lothian, of which some account will be found in the Transactions of the Society, vol. vii. p. 31. It is obvious, that such exceptions must be left out of all calculations, as to the capability of plants becoming naturalised in a given climate.

“Of *Australian* plants, none seem to have been able to bear so much as even $+12^{\circ}$, except *Billardiera longiflora*, which is recorded at Glasgow to have borne -1° at the foot of a south wall, and a *Eucalyptus*, called *alpina*, which escaped at Norwich; it will, however, be probably found that this circumstance is, in both cases, attributable to some unexplained cause. It, therefore, seems useless to attempt to naturalize New Holland plants in the midland and northern parts of England. On the coast of South Wales, where the thermometer did not fall below $+15^{\circ}$, *Leptospermum lanigerum* is the only species which appears to have survived; at Carelew, in Cornwall, where the climate seems generally to be very mild, although the temperature is *reported* to have been $+12^{\circ}$, almost all the New Holland and Van Diemen's Land plants

either perished outright or were irrecoverably damaged; the only exceptions being *Acacia stricta*, *affinis*, *sophora*, and *diffusa*, *Callitris cupressiformis*, *Corræa alba*, *Callistemon lanceolatus*, *Grevillea rosmarinifolia*, *Leptospermum ambiguum*, and *Sollya heterophylla*. It is only in such favoured spots as Mr. Fox's garden at Falmouth, and in the mild climate of Ireland, that any considerable number of Australian plants have proved really hardy, and even in those places a great many species died.

“ Upon the plants of *New Zealand* there is little to remark, except that there seems no probability of their (in many cases) acquiring a permanent station in these islands. *Phormium tenax*, the *New Zealand flax* plant, escaped in a swamp at Carlew; a circumstance that should not be overlooked by those who hope to make it a subject of common cultivation in the milder parts of Ireland.

“ Of the natural habits of *Chinese* plants little is known with precision. Those which we possess in this country have been generally purchased in the market of Macao, and there is no ascertaining whence they are brought. Many, no doubt, are obtained from the northern provinces where the winter cold is severe; and it is to be presumed that they are what we find hardy enough to sustain a temperature of $-4\frac{1}{2}^{\circ}$, or lower. Among these are especially deserving of notice the beautiful *Cunninghamia sinensis*; *Amygdalus pumila*; *Fraxinus lentiscifolia*, a forest tree of the most ornamental character; *Glycine sinensis*; *Juniperus chinensis*, a valuable evergreen; the noble *Yu-lan*, or *Magnolia conspicua*; *Kœlreuteria paniculata*, a fine deciduous tree; tree pæonies; *Taxodium sinense*, and the magnificent climber *Bignonia grandiflora*. Of the *Chinese Azalcas*, *A. indica alba* proved the most hardy. I scarcely know in what light to regard the unexpected fact of *Illicium anisatum* having escaped at Claremont, where it was exposed to a temperature of -12° ; but it is worthy of notice that *I. floridanum* is reported in so many places to be hardy, that no doubt can remain upon that point at least; see p. 490. The fact mentioned by Mr. Dillwyn of *Pittosporum Tobira* not having suffered in South Wales more than *Arbutus Unedo* is important, and renders it desirable that this handsome evergreen should become the subject of experiments as to its hardy qualities elsewhere. That *Thea viridis* should have stood where *T. Bohea* was killed, will doubtless be regarded as an additional proof of the *Black and Green Tea* plants being distinct species.

“ Such *Japanese* plants as have been the subject of experiment, have, in the greatest number of cases, afforded evidence that the vegetation of the colder parts of that region is well suited to our own. If *Eriobotrya japonica*, *Ligustrum lucidum*, *Laurus camphora*, and some others, were unable to resist the winter, probably in consequence of their being naturally found in warm valleys, on the other hand, thirteen or fourteen other shrubs proved hardy, among which are the beautiful new species of *clematis*; and even certain varieties of *Camellia japonica* exhibited a power of enduring cold which could not have been anticipated. I quite agree with Mr. Herbert, that the result of last winter's frost is such as to render it desirable that all the varieties of *camellia* should be tried out of doors, in order to ascertain which are the most hardy.

“ The species native of the *Himalaya Mountains* have resisted the cold to so great an extent, that there can be no doubt of a large proportion of the vegetation of those northern parts of India proving hardy in England, Wales, and Ireland. This fact alone is of the highest interest, because there certainly is no country more accessible to us, or whose productions are more worthy of being imported, whether for their value as timber, their beauty and variety as forest trees, or their brilliancy as mere objects of ornament. The mere knowledge that the noble *Deodar cedar* is capable of enduring the utmost rigour of an English winter is almost alone sufficient to compensate for the destruction produced by the frost among other plants. All the pines and firs appear more or less hardy, except *Pinus longifolia*, which is not a mountain species. *Benthamia fragifera*, although tender in the midland counties, appears at home in

Cornwall and Devonshire; the beautiful Berberis, many Cotoneasters, a Euonymus, Juniperus recurva, Leycesteria formosa, all the Spiræas, Viburnum cotinifolium, and, above all, the magnificent Rhododendron campanulatum, have to be added to our lists of common shrubby plants. Clematis montana too proved so robust, that we have not only secured that beautiful addition to our climbers, among which variety is so much wanted, but have well-grounded expectations that some of the many other beautiful species of the same genus still to introduce, will prove equally suited to this climate. The results of the frost upon the hybrid Rhododendra have been already sufficiently detailed (page 492.), and need not be repeated.

“The plants of the *South of Europe* and adjacent countries have been for the most part so long in cultivation here, that much novelty in the results of the winter cannot be expected with regard to them; nevertheless, some facts prove new, others confirm opinions which were not previously established to the satisfaction of every one, and a few are inexplicable upon any principle with which I am acquainted. That Aristolochia sempervirens, a native of Candia; and Peganum Harmala, a common Syrian plant; Ilex balearica and Buxus balearica, evergreens inhabiting the islands of Majorca and Minorca; Juniperus oxycedrus, quite a southern bush; Pistacia terebinthus, which is not found wild north of the coast of the Mediterranean, should all have been found hardy where such plants as the tamarisk, Arbutus Unedo, and the cypress perished, are results which could hardly have been anticipated. They are, however, of the first importance, because it will induce the more general cultivation of those among them which are beautiful. It is interesting to know that Arbutus Andrachne is more hardy than A. Unedo, — a fact which may perhaps be connected with their very different localities when wild; the former being exposed to the severe cold of South-eastern Europe, while the latter, although wild in Ireland, is more peculiar to the west of Europe. Connected with this is the important fact, that A. Andrachne inarched upon A. Unedo, in which condition it is usually sold in the nurseries, is unfit for planting, because of the tenderness of its stock. By taking care that plants of A. Andrachne, and also A. hybrida, are on their own roots, two fine evergreens may be considered secured to the gardens of the greater part of England. That there should be a variety of the olive hardy enough to bear $-4\frac{1}{2}^{\circ}$ without the slightest injury, may be a fact of value to the olive-grower in many parts of Europe, and renders it probable that this useful tree may be profitably raised for its oil in any part of Ireland. To the fruit-grower the hardness of the Green Ischia fig is a good result, for it will enable this variety to be cultivated much further to the north than it has hitherto been thought possible to possess figs as open standards. The Aleppo pine seems to have generally perished; but Pinus brutia, a Calabrian species very like in habit, seems to be hardy. There has been some difference of opinion as to the comparative hardness of the species of Cerasus called “Laurels” in this country. The fact is now established beyond doubt, that C. lusitanica, the Portugal laurel, is much more hardy than C. laurocerasus, the common laurel. This could not have been expected from what are reported to be the natural habits of those two species; the former inhabiting the mountains of Portugal and Madeira, where the climate is softened by the mild air of the Atlantic, and the latter being found on the mountains of the most eastern parts of Europe and of Persia, where the winters are more rigorous than in western countries. The death of the Sweet Bay and the Laurustinus, on the other hand, corresponds with what might be anticipated from their inhabiting only the warm rifts of calcareous rocks in the south of Europe, where, if their branches are ever killed, their roots are secured against all chances of destruction.

“Of *Cape* plants there is little to observe further than that all the shrubby species are evidently too tender to deserve cultivation, without protection, north of Cornwall and Devonshire. It is, however, satisfactory to find that the hardskinned Cape Bulbs and tuberous Pelargonium will live in the open border, with only the aid of a covering of fern-leaves, provided the border is well

drained; and the undoubtedly hardy habits of *Aponogeton distachyon*, and *Richardia africana*, have secured to us two additional handsome aquatics.

“The low southern latitudes of *South America* have furnished a few accessions to hardy collections, among which the *Araucaria Dombeyi* is the most interesting for the possessors of parks and large gardens, and it has now become an object of some national importance to procure supplies of seeds of this plant from Valparaiso; for to introduce in abundance so remarkable a vegetable production as this is when old, with columnar trunks often 100 feet high, surmounted by a pyramid of grotesque branches, would be an object scarcely less than national, even if the plant did not furnish excellent timber, and an abundance of valuable resin. It also appears that *Aristotelia Macqui*, and the *Escallonias*, *rubra* and *glandulosa*, all beautiful evergreens, are about as hardy as a *Laurustinus*, that the graceful little *Berberis empetrifolia* is regardless of cold, and that *Colletia horrida*, *Duvaua ovata*, and *Heimia salicifolia*, also seem likely to bear this climate. The preservation of herbaceous plants is less important; but it is satisfactory to know that some at least of the *Alströmerias* may be henceforward regarded as hardy border flowers.

“The number of *Californian* and *Mexican* plants in our gardens, which have been the subject of experiment, is inconsiderable. Of these it is found that the species from California are more tender than those from Mexico: a circumstance doubtless to be explained by the Californian species having been taken indiscriminately from warm valleys and mountain sides, while no one has thought of naturalizing any Mexican species except from the cold mountain ridges. What is most important is that all the beautiful pines and firs from these regions, of whose habits so little was previously known, prove to be perfectly hardy wherever they have been tried, with the exception of *Pinus insignis* and *P. leiophylla*.

“The winters of *North America* are usually so rigorous north of the districts warmed by the Gulf of Mexico, that to state that a plant is from the United States, is usually equivalent to saying it is hardy. There are, however, some exceptions to that rule, and it was requisite to possess the experience of such a winter as this, in order to judge whether the plants from the British possessions on the Pacific would be as hardy as those from the Atlantic side of the Rocky Mountains. The latter seems now to be well established, for of all the numerous valuable plants introduced by the Society from North-west America, not one of any importance, with the exception perhaps of *Arbutus procera*, proved tender; and what is of the utmost practical importance, it is now clear that *Abies Douglasii*, a species that grows as fast as the larch, which has much better timber, is evergreen, and grows to an enormous size, is perfectly suited to the climate of Great Britain. *Yuccas* also resisted the frost so very generally, that they may be safely introduced into gardens as hardy endogenous shrubs; and the same observation applies to *Vaccinium ovatum*, one of the handsomest of evergreens. That *Pinus palustris* should have so generally perished may be a matter of regret, but can excite no surprise considering that it is exclusively a native of the southern states of the North American union.

“Not the least interesting of the facts observed during this winter was this; that in those places where the cold was *very severe*, the more plants were exposed the less they suffered, and that on the contrary, the more they were sheltered without being actually protected artificially, the more extensively they were injured. Thus in the Garden of the Horticultural Society, in a warm soil, and much sheltered by other trees, old plants of the common *Arbutus* were killed to the ground, or entirely destroyed, while in my own garden, in a cold wet soil, the *Arbutus* did not suffer at all; and in like manner, cistuses of all descriptions were in the former case totally destroyed, while in the latter, *C. Cyprius*, and *C. corboriensis* were scarcely injured. At Kew, in the warm Botanic Garden, and sheltered by mats and a wooden frame, a fine old plant of the Chilian *Araucaria* perished at the extremities, and at Highclere, the seat of the Earl of Carnarvon, that plant suffered in a sheltered

situation among trees ; but it passed the winter perfectly uninjured, with the thermometer at -5° , in the same place, when planted upon the open lawn, exposed to all the severity of the weather. In many places the vine was killed in Vineries, the fires of which had not been lighted, while it received no harm upon the open wall. At the village of Great Malvern, a very cold and exposed place, situated on the eastern slope of a ridge of high hills, Mr. Dillwyn found that none of the evergreens were at all injured, though they suffered severely on the plain, two or three hundred feet below the village, and in the neighbourhood of Worcester, which is only eight miles distant. This corresponds with a remark made by White in his *Selborne*, letter 63, that in the severe frost of 1784, his evergreens suffered much in his warm sequestered garden, while those in such an *exalted* and near situation as Newton were uninjured. Mr. Williams observed, that at Cheltenham there was a very marked difference between the injury sustained by plants in the lower part of the town, and in the higher ground above the 'Montpellier Spa;' in the former, the *Laurustinus* were turned brown and withered; in the latter, they in a great measure escaped. In the low ground at Brenchley, the *Arbutus* was killed, but on higher levels it escaped; and in the same place, under the same circumstances, the double white *camellia* escaped, but the single red was killed; in short, the general rule was found by Mr. Hooker to be, that those plants the most sheltered from the north, and open to the south and south-east, were the most injured, but on the high grounds, open to the north and screened from the south, plants suffered much less; there, many of the most hardy kinds of standard Chinese roses escaped, and the hollies, laurels, and Portugal laurels were not in the least injured. At Brenchley there are some extensive Portugal laurel hedges, which run from the highest to the lowest parts of the grounds; these presented a striking instance of the effects of the frost; in the lowest part they were quite killed to the ground, were gradually less injured as the ground rises, and on the upper part of the ground the hedges were in a fine healthy state. Mr. Philip Davies Cooke tells me that he saw in Wales a shrubbery at least six hundred feet above the sea, as little, if not less injured than those in lower regions, and a fig-tree, against a house above 500 feet above the sea, putting out leaves although it had not had any protection whatever. At Dropmore, *Photinia serrulata*, where sheltered, had its branches killed down to the main stem, while another plant in a more exposed situation suffered but little injury. At Redleaf, Portugal laurels, in high situations, escaped with scarcely any damage, while they suffered severely in low and warmer places. At Owston, near Doncaster, the Banksian roses were destroyed in warm places, but against a wall, completely excluded from the sun, they were but little injured. Among other things lost at North Stoneham, was a *Rosa multiflora*, 30 feet high and 30 feet wide, in full vigour, and upwards of 20 years old, against the south part of the house. Could it have been sheltered from the influence of the sun, and consequent unprepared and violent exposure to frost, Mr. Beadon does not conceive that he should have lost it. At Belsay, in Northumberland, Sir Charles Monck found a great difference between the effects of the frost in a new garden, in a low, dry situation, and in an old one, placed at an elevation above the sea many feet higher; in the latter a tree of the sweet bay was only a little scorched in the leaves, *Viburnum strictum* and evergreen oaks were unhurt, and *Pinus halepensis* but little injured; but in the former, that is in the low, warm garden, cypresses of 7 years' growth were mostly killed, *Quercus Gramuntia*, white broom, *Colletia serratifolia*, *Ilex Perado*, rosemary, *Anagyris indica*, *Buxus balearica*, *Buddleia globosa*, the *Fuchsia*, *Yucca*, *Cistus*, *Laurustinus*, *Arbutus*, and *Erica arborea*, were killed, or killed to the ground at least. It is useless to multiply such facts. They, and all of a like nature, however paradoxical they may appear, are no doubt to be explained on the same principle as the practice of selecting a northern exposure for Moutan pæonies, and similar plants, which are apt to suffer from early spring frosts.

It is well known, that plants in a state of growth suffer more from frost, than those which are dormant. I have seen young shoots of the oak, and ash, blackened by frost in the month of June, in the hedgerows of Norfolk and Suffolk, and yet we know how capable are those natives of the soil of resisting with impunity our severest winters. This is undoubtedly owing in a great measure, if not exclusively, to their tissue containing much more fluid when in a growing state, than when they are dormant. The more succulent a plant, or a part of a plant, the more tender it is under equal circumstances. An oak, or an ash, is nearly exhausted of its fluid contents by the leaves, before the frost sets in, and, in fact, the fall of those organs in deciduous trees is probably caused, in part, by the inability of the stem to supply them in autumn with an adequate quantity of fluid food; during the winter, but little water is added to the contents of the stem, until after the severest frosts are past and the return of spring, when the sap is attracted upwards by the budding leaves. The winter, therefore, is the dry season of such plants, and for that reason the period in which they are least liable to the effects of frost. But if any unusual circumstance alters this habit, the capability of resisting frost is altered with it; and thus the arbutus, the vine, the araucaria, and the other plants mentioned in the instances lately quoted, stationed in warm sheltered situations, were stimulated prematurely into growth, their stems were filled with fluid, and they were, in consequence, affected by frost in a much greater degree than when, from the coldness of a station, they were kept in their ordinary winter condition.

Nothing seems more generally to have excited surprise, than that so many plants, apparently killed, sprang up again from the roots. Hence it has been generally said, that many species which would have survived, if undisturbed, were thrown away, in the eager haste of gardeners to remove objects, which had become unsightly. Some have indeed ignorantly imagined, that the mere act of cutting dead stems down had the effect of destroying the lingering vitality of the root. No person, in the slightest degree acquainted with the nature of vegetable life, could entertain such an idea as the last; but for the first, there is no doubt some foundation. In all cases, the roots of trees suffer from frost less than the stems, partly perhaps because the vitality of a root is greater than that of a stem, as Mr. Knight long since showed; but more especially because they are so much less exposed to cold. That the earth, being a bad conductor of heat, should remain in winter at a higher temperature than the superincumbent atmosphere will excite no surprise; but probably few persons are aware to how small a degree the temperature of the earth is lowered in this country, during even long-continued and severe frost. In order to measure the exact difference between the temperature of the earth, and the air, experiments have for some time been in progress in the Society's Garden. Two thermometers have been buried in the earth, one at the depth of 1 foot, the other at the depth of 2 feet, and their indications have been noted daily. It will be seen, from the following table, that the ground was never frozen to the depth of a foot, in the Society's Garden, even while the temperature of the surface was as low as $4\frac{1}{2}^{\circ}$ below zero, and that it did not fall to within 5° of freezing at the depth of 2 feet during the same period. I cannot pretend to explain the discrepancy between this statement, and the observations of those who have found the earth frozen to the depth of more than 2 feet during the past winter, especially, as the soil in which my observations were made is far from dry; but the fact as now stated is certain. In order to check the geothermometrical observations, I caused the earth of the garden to be broken up during the frost, for the purpose of ascertaining how deep the soil was hardened, and the result was as follows:—In the Kitchen-garden quarter, 9 inches; in a hard loam foot-path, 10 inches; in the Arboretum, adjoining the geothermometers, 8 inches; in the Arboretum, where the turf is chiefly composed of moss, 5 inches.

Register of Geothermometers in the Garden of the Horticultural Society in the Month of January, 1838.

		1 Foot deep.	2 Feet deep.				
January	1	46	46	January	17	34	38
	2	46	46		18	34	37½
	3	45	46		19	33½	37
	4	42	43		20	33	37
	5	42	44		21	33	35
	6	41	44		22	33	35
	7	40	43		23	33	36
	8	39	41		24	33	36
	9	37	41		25	33	36
	10	36	40		26	33	35
	11	36	40		27	33	35
	12	36	40		28	33	35
	13	35	39		29	33	35
	14	35	39		30	33	36
	15	34½	38		31	33	35½
16	34	38					

“ It will doubtless have been remarked, that in the previous observations, it has been assumed that the destruction which took place among plants was owing to the intensity of the cold on the morning of the 20th of January. I am aware that, in the opinion of some intelligent observers, it was not so much the excess of cold which produced death, as the subsequent thaw, either on the 22d of January, when the thermometer rose to 46°, or in the end of the month, and in February. This opinion seems to be formed upon the absence of any appearance of death in some cases till that time, and also upon the well known fact, that frozen vegetables and trees, suddenly thawed, will die, while they recover, if the temperature is raised by slow degrees. The absence of the appearance of death in certain plants, till some time after it actually takes place, is perhaps owing to the decomposition, which is induced by the intensity of cold, either being suspended so long as they remain frozen, or proceeding very slowly in cold weather. That it really was the excessive cold, which in general produced destruction, may be concluded from this; that such effects as we experienced last winter are not observed in milder winters, in which rapid thaws succeed severe freezing; and, because it seems certain from what we know of plants, that it is not the mere act of freezing, or unfreezing, that destroys vegetable life; it is necessary that the amount of freezing should reach some unknown point, which seems to vary in different species. Dr. Neuffer has shown (*Edin. New Phil. Journ.*, 1830, p. 141.), that trees are frozen within certain limits without apparent injury. In some trees, he ascertained that the temperature was lowered to +5°, or even to +1½°, without the power of vegetation suffering; so that the reduction of vegetable tissue by cold into that state which is succeeded by an immediate decomposition of the organic parts, varies in different species according to their peculiar nature.

“ In considering the various circumstances alluded to in this paper, I was naturally led to inquire into the exact manner in which the death of plants is caused by cold. Very little, however, is to be learned upon this subject from the writings of physiologists.

“ The common opinion is, that frost acts mechanically upon the tissue of plants, by expanding the fluid they contain, and bursting the cells or vessels in which it is enclosed.

“ M. Gœppert, of Breslau, in a paper, originally read at the meeting of German naturalists at Leipsig in 1829, briefly abstracted in *Oken's Isis* for 1830, p. 497., and translated in the *Edinburgh Journal of Natural and Geological Science* for 1831, p. 180., denies that this supposed laceration of vege-

table tissue by frost takes place. He is represented to have stated, that the changes which plants undergo, when they are killed by cold, do not consist in a bursting of their vessels or cells, but solely in an extinction of vitality, which is followed by changes in the chemical composition of their juices.

“Professor Morren, of Liège, in a paper, printed in the fifth volume of the *Bulletin de l'Académie Royale de Bruxelles*, has published some exceedingly interesting observations upon this subject. Like M. Gœppert, he denies the truth of the statement generally made, that frost produces death in plants by bursting their vessels; and he assigns the effect to other causes. His more important conclusions are, 1. That no organ whatever is torn by the action of frost, except in very rare cases when the vesicles of cellular tissue give way, but that the vesicles of plants are separated from each other by frost without laceration. 2. That neither the chlorophyll, the nucleus of cells, elementary fibre, amylaceous matter, raphides, nor the various crystals contained in vegetable tissue, undergo any alteration, unless perhaps in the case of amylaceous matter, which in some cases is converted into sugar, no doubt, in consequence of the action of some acid, formed by the decomposition of the organic parts. 3. That the action of frost operates separately upon each individual elementary organ, so that a frozen plant contains as many icicles as there are cavities containing fluid; the dilatation thus produced not being sufficient to burst the sides of the cavities. 4. That such dilatation is principally owing to the separation of the air contained in the water. 5. That this disengagement of air by water during the act of congelation, is the most injurious of all the phænomena attendant upon freezing: introducing gaseous matter into organs not intended to elaborate it, and bringing about the first stage in a decomposition of the sap and the matters it precipitates; so that with a thaw commences a new chemical action destructive of vegetable life. 6. That the expansion of the cells, and aquiferous organs, drives a great quantity of water into the air-cells, and air-vessels, so that the apparatus intended to contain liquid only, contains water and air, while that which is naturally a vehicle for air conveys water. Such an inversion of functions must necessarily be destructive to vegetable life; even if death were not produced in frozen plants by the decomposition of their juices, the loss of their excitability, and the chemical disturbance of all their contents.

“Professor Morren's observations were made upon various plants frozen in the spring of the present year, having been exposed to a temperature of -4° to $+9^{\circ}$ Fahrenheit. One of his statements I give in his own words. ‘In the parenchyma of many plants, and especially in that of succulent fruits, it is easy to ascertain what modifications are caused by frost in the internal organs of plants. If a frozen apple is opened, it is obvious that the ice is not a continuous mass, but that it is a collection of a multitude of little microscopical icicles. Under the microscope the fact becomes evident. We know how excessively hard some fruits become when frozen by this mosaic of icicles, especially pears. If we thaw them, it is seen that on the instant a multitude of air-bubbles are extricated from the juice of the fruit, and that this juice has then acquired new chemical qualities. I wished to ascertain the cause of these phænomena, and the following is what observation has shown me. I studied for this purpose more particularly the tissue of the apple. Each cell is filled with a small icicle, which has in its middle a bubble of air. We know that when water freezes, the crystals so arrange themselves, that the air separated from their mass by the solidification of the liquid is intercalated between their planes. This air also places itself in a mass of congealed water in a regular manner, the nature of which depends entirely upon that assumed by the crystals, as may be seen by freezing water in a cylindrical vessel, when the air-bubbles always assume the form of a very long cone, terminated by a spherical cap. The augmentation of the volume of water is in great measure owing to this interposition of masses of air. All these effects take place in each cell of a frozen apple, which thus increases in size because each cell of its tissue becomes individually larger. When thawed, the cell recovers itself by the elas-

ticity of its vegetable membrane, and frozen fruit becomes, as we know, very much shrivelled. Each cell, therefore, acts like a bottle of frozen water, only there is no bursting, because the membrane is extensible.'

"But when plants, easily killed by cold, are exposed to so low a temperature as that just described, it is to be feared that phenomena actually connected with the destruction of vegetable life may be intermixed with others, which merely indicate the physical effects of cold upon vegetable matter already dead. For the purpose of judging how far this conjecture is well founded, I have carefully examined the *post mortem* appearances of several plants killed by exposure to a temperature artificially reduced only to from 28° to 30° Fahrenheit. These observations, while they have confirmed the general accuracy of Professor Morren's statements, have led to other conclusions which also appear important.

"I could not find the vesicles of cellular tissue separable from each other, even in the most succulent species submitted to experiment, and I conclude that this circumstance, to which Professor Morren attaches importance, and to which M. Payen ascribes the difficulty of extracting starch from frozen potatoes, is not so much connected with the destruction of vegetable life as a result produced upon the tissue by a great intensity of cold. I did, however, find it lacerated in several cases, as if by the distension of the fluid it had contained. In a *Stapelia* the whole of the cellular tissue was soft, and deformed, as if it had been extended, with but little power of recovering itself again, and several large irregular lacerated cavities were observed. The same appearances were remarked in *Euphorbia Tirucalli*, but the laceration of the tissue was much less extensive. In *Hibiscus Rosa Sinensis* the cells of the cortical integument (mesophloëm) were very much torn, and in *Hibiscus militaris* not only the cells of the bark, but especially those of the pith, were so completely broken up, that it was difficult to obtain a thin slice of those parts for examination. In no case, however, have I found any kind of tissue ruptured, except the soft cellular dodecahedral or prismatical. It would also seem that M. Payen recognises the laceration of tissue by frost, for he ascribes the acidity of frozen potatoes to an extravasation of the acrid matter which exists in the epiphloëm of such tubers, and which, in a natural state, is locked up in the cells of which that part consists. Independently of these observations, it is not to be doubted that frost does split the tissue of plants. I saw the youngest shoots of *Erica mediterranea*, *cinerea*, and others, shivered into thousands of pieces in the Horticultural Society's Garden, on the morning of the 20th of January. The branches of *Melaleucas* were rent to their points at Carlew. Several cases, among others that of the common holly, were observed at Claremont, where the bark was split, and rent asunder from the wood below it; and Sir Oswald Mosley has given me the following instance, which occurred under his own observation. 'An oak tree, growing upon the south side of a hill, in a sheltered situation, in Knightly Park, near Burton-upon-Trent, in the county of Stafford, was rent in the severe frost of last winter in two different places, to the height of 13 ft. 3 in. There was an interval of 11 in. between the two shakes, which were each of them one quarter of an inch wide, and extended in depth to the heart of the tree. The girth of the tree is 6 ft. 10 in., and as soon as the frost went the openings closed again, and the tree is now as flourishing as ever.' To these cases many more might be added.

"The organisation of woody tissue appears to be affected, but not by laceration. If a frozen and unfrozen transverse slice of the stem of *Hibiscus Rosa Sinensis* be placed, side by side, upon the field of the microscope, it is obvious that the diameter of the tubes of the wood and liber is considerably less in the former than in the latter; this appears to be owing to an increase in the thickness of the sides of the tubes, which has the effect of diminishing their calibre.

"The expulsion of air from aeriferous organs, and the introduction of it into parts not intended to contain it, is a striking phænomenon. Every one must

have remarked that when a leaf has been frozen to death, it changes colour as soon as thawed, acquiring a deeper green, and being of nearly the same depth of colour on both sides; the same appearance is produced by placing a leaf under the exhausted receiver of an air-pump, and in both cases is owing to the abstraction of air from the myriads of little air-chambers contained in the substance of this organ. If the leaf of *Hibiscus Rosa Sinensis* in its natural state is examined, by tearing off the parenchyma from the epidermis with violence, it will be found that the sphincter of its stomates, the cells of the epidermis, and the chambers immediately below the latter, are all distended with air; but in the frozen leaf of this plant, the air has entirely disappeared; the sphincter of the stomates is empty; the upper and under sides of the cells of the epidermis have collapsed, and touch each other, and all the cavernous parenchyma below the epidermis is transparent, as if filled with fluid. Whether the air is conveyed is not apparent; but as the stomates have evidently lost their excitability, and are in many cases open, it may be supposed, that a part of the air at least has been expelled from the leaf; and as the pith of this plant, in its natural state, contains very little air, and in the frozen state is found to be distended with air, it is also probable that a part of the gaseous matter expelled from the leaf when frozen is driven through the petiole into the pith. In the petiole of this plant are numerous annular and reticulated vessels, which under ordinary circumstances are filled with air, but after freezing are found filled with fluid; is it not possible that their functions may have been disturbed, by the violent forcing of air through them into the pith, and that when that action ceased, they were incapable of recovering from the overstrain, and filled with fluid filtering through their sides? That annular ducts are in some way affected by frost was shown by their state in a thawed branch of *Euphorbia Tirucalli*, when they were found in a collapsed state, empty of both air and fluid, with their sides shrivelled, and with the fibre itself, which forms the rings, also wrinkled transversely. Facts of an analogous kind were remarked by me in *Erica sulphurea*. The minute long-haired leaves of this species are in their natural state firm, bright green, with a rigid petiole, and upon being exposed to pressure in a *compressorium*, at first offer perceptible resistance to its action, and afterwards, as the pressure increases, discharge, chiefly through their petiole, a great quantity of air. But leaves of this plant, which have been frozen by exposure to the temperature of 27° are very different; they are softer, dull olive green, with a flaccid petiole, and offer but little resistance to pressure; yet, although they give way freely, the quantity of air which the *compressorium* expels is comparatively small, and readily driven out. Moreover, the long hairs of this plant, which in the natural state are occupied by fluid, were always found filled with air after freezing, and this without pressure having been exercised upon them.

“I am inclined to refer to this cause the well-known fact, of which many cases occurred this winter, that the sudden exposure of frozen plants to warmth will kill them; though they may not suffer if warmed gradually. In such cases, it may be supposed that the air, forced into parts not intended to contain it, is expanded violently, and thus increases the disturbance already produced by its expulsion from the proper air cavities; while, on the other hand, when the thaw is gradual, the air may retreat by degrees from its new situation without producing additional derangement of the tissue. It is also possible that leaves, from which their natural air has been expelled by the act of freezing, may, from that circumstance, have their tissue too little protected from the evaporating force of the solar rays, which we know produce a specific stimulus of a powerful kind upon those organs.

“These circumstances are, in themselves alone, sufficient to account for death being produced in plants by frost; and it is chiefly to such as these, that Professor Morren has directed his attention. It however appears to me that there are some other points of importance to which observers have not applied themselves.

“The green colouring matter of leaves, or chlorophyll, is certainly affected

by so little as only two or three degrees of frost. In *Stapelia*, when thawed, it is found collected into clusters, and apparently half dissolved. In *Euphorbia Tirucalli*, when the plant is alive, it is extremely abundant, and consists of distinct spheroidal transparent particles, but, after a slight freezing, a considerable part of it disappears, and the remainder loses its transparency, becomes fusiform, is sometimes surrounded by coagulated gelatinous colourless matter, and many of the particles appear as if burst. In the green subcutaneous parenchyma of the leaf of *Hibiscus Rosa Sinensis*, the vesicles forming the sides of the air chambers are filled with distinct, angular, deep green particles, which, after freezing, become amorphous, and seem as if partially dissolved. It is possibly to the decomposition, of which these appearances are the incipient signs, that the extremely offensive odour of some frost-bitten plants, especially the *Laurustinus*, when thawed, is to be ascribed.

“The amylaceous matter, which is so abundant in many plants, also undergoes alteration. This has been remarked by Professor Morren, who found that when potatoes are frozen, a part of their starch disappears, leaving the deformed integuments behind it, and he suspected that the starch thus lost had furnished the sugar formed in the process of freezing this tuber. I believe it will be found a general fact, that starch is materially altered by frost, for I have always found that the amylaceous particles seem less abundant in a plant after freezing than before, and of those which remain, a part is generally becoming amorphous, clustered together, and certainly diminished in size. This is particularly striking in *Hibiscus militaris*. In that plant the cells of the pith abound in amylaceous granules, and are often quite filled with them; and they also occur abundantly inside the cells of the bark, of the medullary rays, and even of the tubes of the wood, and, in short, everywhere except inside the woody tubes of the liber; so that a thin slice of the stem of this plant, treated with iodine, forms a most beautiful microscopical object. But after being frozen, a great part of the starch disappears, and the particles which remain are not more than a half or quarter their former size. I have not, however, remarked among them any appearance of dissolving; neither have I been able to observe any change in the curious double-headed bodies, in form resembling dumb-bells, found in the vessels of *Euphorbias*, and supposed to be a state of amylaceous matter, because iodine colours them violet; they appeared to me to be in precisely the same state before and after the plant was frozen to death. M. Payen, however, denies that any starch whatever is lost in frozen potatoes (*Comptes rendus*, vi. 345.); but as only a small part of his important treatise on amylaceous matter has reached this country, I am unable to state in what way he explains the action of cold upon this substance.

“Finally, it appears that frost exercises a specific action upon the latex, destroying its power of motion. If, as Professor Schultz supposes, this is the vital fluid of plants, such a fact would alone account for the fatal effects of a low temperature. In all the cases I have observed frost coagulates this fluid, collecting it into amorphous masses. In *Stapelia*, where the laticiferous vessels are easily found, the latex itself is so transparent, that it is difficult to perceive it in a living state, even with the best glasses; but after freezing it is distinctly visible, resembling half coagulated water. In the *Hibiscus* above mentioned, the stem is covered with long, rigid, simple hairs, filled with a plexus of capillary laticiferous vessels of extreme tenuity, but in which the motion of the latex may be seen beautifully with the $\frac{1}{5}$ of an inch object glass of an achromatic microscope. Upon being thawed, after freezing, all this apparatus is found reduced to some misshapen separate sacs of fine grumous matter, in which no motion can be detected. That these vessels lose their vitality after freezing, may indeed be seen without the aid of a microscope; for if a stem of a *Ficus elastica*, or a *Euphorbia*, or any such plant, which discharges an abundance of milk when wounded, be first frozen, and then thawed, no milk will follow the incision.

“From these facts, I think we must draw the conclusion, that the fatal effect of frost upon plants is a more complicated action than has been supposed; of which the following are the more important phænomena:—

"1. A distension of the cellular succulent parts, often attended by laceration; and always by a destruction of their irritability.

"2. An expulsion of air from the aeriferous passages and cells.

"3. An introduction of air, either expelled from the air passages, or disengaged by the decomposition of water, into parts intended exclusively to contain fluid.

"4. A chemical decomposition of the tissue and its contents, especially of the chlorophyll.

"5. A destruction of the vitality of the latex, and a stoppage of the action of its vessels.

"6. An obstruction of the interior of the tubes of pleurencyhma, by the distension of their sides.

"These phenomena may be considered in part mechanical, in part chemical, and in part vital. The two latter are beyond our controul, and probably depend, in part, upon the quality of fluid and organic matter, which may resist the action of cold in different degrees, according to their various modifications; and, in part, upon specific vitality. Salt and water freeze at various temperatures, according to the density of the mixture, from 4° to 27°; oil of turpentine at 14°; oil of bergamot at 23°; vinegar at 28°; milk at 30°; water at 32°; olive oil at 36°; oil of anise at 50°; and it is not to be doubted, that, in like manner, the fluid contents of plants, which we know are infinitely modified, will resist the action of cold in very different degrees.

"The mechanical action of frost may however undoubtedly be guarded against to a great extent. It is well known, that the same plant growing in a dry climate, or in a dry soil, or in a situation thoroughly drained from water during winter, will resist much more cold, than if cultivated in a damp climate, or in wet soil, or in a place affected by water in winter. Whatever tends to render tissue moist will increase its power of conducting heat, and consequently augment the susceptibility of plants to the influence of frost; and whatever tends to diminish their humidity, will also diminish their conducting power, and with it their susceptibility; this is an invariable law, and must consequently be regarded as a fundamental principle in Horticulture, upon attention to which all success in the adaptation of plants to a climate less warm than their own will essentially depend. The destructive effects of frost upon the succulent parts of plants, or upon their tissue when in a succulent condition, may be thus accounted for, independently of the mechanical expansion of their parts; indeed, it is chiefly to that circumstance, that Dr. Neuffer ascribes the evil influence of cold in the spring; for he found, that at Tübingen nearly all trees contain 8 per cent. more of aqueous parts in March than at the end of January; and the experience of the past winter shows, that the cultivation of plants in situations too much sheltered, where they are liable to be stimulated into growth, and consequently to be filled with fluid, by the warmth and brightness of a mild protracted autumn, exposes them to the same bad consequences as growing them in damp places, or where their wood is not *ripened*, that is to say, exhausted of superfluous moisture, and strengthened by the deposition of solid matter, resulting from such exhaustion."

MISCELLANEOUS INTELLIGENCE.

ART. I. *General Notices.*

STEELE'S improved Kitchen-Range.—Messrs. W. and P. Steele, the most extensive manufacturing and furnishing ironmongers in Edinburgh, have lately completed a kitchen-range which appears to us to be by far the most complete apparatus of the kind hitherto brought under public notice. Though chiefly calculated for large establishments, yet it may be so far reduced in dimensions, as to be put up for 25*l.*; though, for large mansions, club-houses, hotels, &c., it will cost from 50*l.* to 100*l.* There are two features in it which are new

and to us very satisfactory. 1st, A power of heating a reservoir of water at the top of the house, 100 ft. or more above the level of the boiler, from which hot water can be distributed all over the house for baths, washing, housemaid's closets, or other purposes. This has been done before, but never in such a manner as to be perfectly free from liability to accidents. 2d, A mode of cleansing the cisterns effectually, without any further trouble to servants than merely turning one or two cocks. There are roasting-ovens on the principle of Mr. Strutt's; a boiling-table, or hot hearth, like Count Rumford's; arrangements for steaming or boiling to any extent; and the whole is effected by one fire, which is open, and before which meat may be roasted in the usual manner. The drawings have been explained and detailed to us by Mr. Steele, and also to a number of London architects, and some ranges are in the course of being put up both in England and Scotland. A more detailed description will be given in the forthcoming Supplement to our *Encyclopædia of Cottage Architecture*; and, in the mean time, this notice will, we trust, be duly prized by such of our readers as are building, and can afford to lay out 25*l.* or 30*l.* for a kitchen-range. — *Cond.*

Ironwork coated with Gas Liquor, Tar, or Pitch, is found to be far less durable than when painted with lead and oil, in the usual manner. I do not know how to account for this chemically, but such is the fact. The oxidation is greatly accelerated in a damp situation, but it takes place even in coal-scuttles kept in dry rooms. Of course the circumstance of gas liquor being unfit for preserving iron does not militate against its fitness for preserving wood. — *P. S. Edinburgh, July 29. 1840.*

ART. II. Domestic Notices.

ENGLAND.

ENVILLE, the Seat of the Earl of Stamford, in Worcestershire. — I last week visited Enville, being one of the few old liberally conducted establishments at the present time in existence, and sincerely hope His Lordship may live long to administer to the wants of all around him with the same generosity as heretofore. The plants, as usual, were looking remarkably well under the able superintendence of Mr. Beddard. There is a large house for orchidaceous plants, containing many rare species: there are some very fine specimens of *Stanhopea*, *Gongora*, and *dendrobiums*; also a fine plant of *Aérides odoratum* in full flower, bearing three scapes of beautiful and delightfully scented flowers; with many others equally interesting. In the forcing department, in the management of which Mr. Beddard has for many years been so successful and celebrated, there were some very fine productions, especially pines, melons, &c.; the peaches were in finer perfection than we ever before saw any. As we enter the pleasure-grounds on the north-west side of the hall, a beautiful picture presents itself, looking over an extensive lawn and plantations. On the lawn are some of the finest specimens of ornamental trees and shrubs in England; especially some magnificent limes, one of them branching close to the ground, and measuring upwards of 110 yards in circumference; also very fine Spanish chestnuts, purple beeches, deciduous cypress, *Rhus Cótinus*, &c. &c. The woods and plantations, at this season of the year, present a most pleasing spectacle. — *L. P. Handsworth, near Birmingham, June 23. 1840.*

ART. III. *The Royal Botanic Society of London, Inner Circle, Regent's Park.*

THIS Society is now so far established, that, after combating many conflicting opinions, they have settled upon a highly approved design for laying out the gardens, and feel themselves in a condition to make an application to the members for the purpose of raising a sum sufficient to complete immediately the laying out of the gardens to such an extent, and in such a manner, as may gain the entire confidence of the well-wishers of the Institution.

The Committee recommend to the Council as follows : — “ That the proposed sum of 5000*l.* be raised by the issue of debentures for sums of 100*l.* and 50*l.* each to such parties as shall be willing to advance such amount for a period of five or seven years, and that such debentures shall bear interest at the rate of five per cent per annum, payable half-yearly.”

Report of Decimus Burton, Esq., the Architect, and of Mr. Robert Marnock, the Curator, dated 15th July, 1840.

“ In accordance with the resolution of the Council passed on the 2d inst., we have designed the accompanying plan for laying out the gardens in the Regent’s Park, and beg leave to submit the following explanatory report.

“ It appears to us a matter of certainty that a Botanic Garden, placed in so favourable a situation, would become a popular place of resort for the higher and middle classes, admitted as at the Zoological Society’s Gardens, provided the ground be laid out ornamentally, at the same time with due regard to scientific arrangement ; and as regards the suitability of the site, with reference to the scientific objects of the Society, it may be proper to state, that it is the decided opinion of the Curator, that, whilst there are a few tender plants which cannot be brought to perfection in this situation, there is an infinite variety of others abundantly sufficient for all the purposes of science and ornament, and which may be cultivated here with complete success. But inasmuch as the first as well as the annual cost of establishing and maintaining such garden must necessarily be heavy, and as the fund wherewith to defray these costs will, it is considered, be chiefly derived from visitors to the spot, seeking relaxation and amusement rather than science, to attain permanent success, the garden must be made attractively ornamental as well as scientifically useful. It should eventually contain a large extent of glass houses, with a continuous covered access from the public road, to form a Winter Garden, the atmosphere of which should be maintained temperate and pure, and in these houses a succession of flowering plants should be exhibited, with the object of giving the opportunity to enjoy a healthful and agreeable promenade in all seasons.

“ Varieties of surface should be effected, as well under glass as in the open garden ; excavations should be made for ornamental water, and eminences raised to break the present monotonous level, and whence to obtain views over the beautiful district of the park, the hills of Hampstead, Highgate, &c. Perhaps there is no other more effectual means of rendering the garden attractive than by diversifying the surface, and in proportion to the extent of artificial undulation will be the advantages of shelter and aspect afforded for the more successful cultivation of tender plants ; so that the more ornamental the ground is made in this respect, the better it will be adapted for the objects of science. With permission of the Commissioners of Her Majesty’s Woods, &c., trees should at intervals be removed from the present formal belt by which the circle is walled in.

“ The principal entrance to the garden should be from the south-west, opposite the Bridge Road, and from which a broad avenue-walk should lead directly to the Conservatory or Winter Garden, and which should be placed on terraces at the opposite extremity of the garden, in order to give length and effect to this avenue, which should be skirted on each side with lawns and groups of ornamental trees, and terminated with flower-borders, vases, fountains, &c., in and about the conservatory. It would be convenient to have an exit gate opposite the road leading to Chester Terrace (constructed on the principle of those at the Zoological Society’s Gardens), and also one to admit parties here to the Winter Garden with check-tickets obtained at the principal gate.

“ As the Society will be restricted from using water from the present reservoir, and as there is no other supply at present in the garden, it will be advisable to sink a well and to erect a steam-engine and cast-iron tanks ; the latter should be elevated on earthen mounds. The first cost of the well, the steam-engine, and tanks would most likely not exceed 1800*l.*, and the

annual cost of working the steam-engine would be about 120*l*. The Commissioners of Woods would probably pay the Society for the surplus water, if, after flowing through the fountains and lakes in the garden, it were carried to the lake in the Park.

“ With reference to the question, ‘ To what extent the plan can be carried out for a sum not exceeding 5000*l*.?’ it is considered that this sum will not more than suffice for the proper carrying into effect the following works, viz. : 1. The entrance gates and lodge opposite the Bridge Road, say at a cost of 500*l*. 2. The principal avenue, with the lawns and shrubberies immediately adjoining. 3. About one half of the walks. 4. The enclosure bank (and which should be irregular as to height and width, and planted or turfed at intervals, as it may be desirable to admit or exclude views). 5. The drainage. 6. A portion of the works required in excavation for the ponds, and in forming hills to give a variety of surface to the garden. 7. The preparation of the plots of ground designed for scientific purposes. 8. The sowing with grass seeds, to form temporary lawns, those parts of the garden which cannot be at first completed.

“ If the sum necessary for obtaining a supply of water from the deep spring cannot now be raised, it will be advisable to make an arrangement with the West Middlesex Water-work’s Company for such supply only as is absolutely necessary for watering the plants and lawns, and to defer the formation of the fountains, ponds, &c., until other arrangements can be made.

“ It is particularly desirable that the ground should be cleared of perennial weeds this autumn, because, unless this be attended to, either the laying out of the garden must be deferred for another year, or the earth will be laid down full of weeds as it now is, which would occasion an inconvenience and future expense to the Society, the amount of which it would not be easy to calculate. If the formation of the garden be commenced immediately, the principal avenue or straight walk, with the grass lawns and ground designed for the medical and other scientific arrangements of plants, with part of the smaller walks, might be completed by the month of May next, so that a large portion of the garden might then be in a state of forwardness, and fit for the admission of subscribers and the public.

“ It has been thought premature at this time to propose plans for lecture-rooms or museum, the site for which, however, should be near the eastern lodge, as well as, perhaps, a library and refreshment-rooms, the funds for establishing which may probably, without injury to the objects of the Society, be derived from another source.

“ We beg to conclude by requesting that the plan and the report may be considered as intended to afford explanation of our general ideas on the subject. We trust that they will prove sufficient for the immediate purpose, and that the Council may so far approve the principle on which we have proceeded in preparing these documents as to require from us further details, with a view of prosecuting works to establish an Institution which may, doubtless, if judiciously managed, be made to advance the objects of science, to afford a delightful source of health and recreation to the public, and at the same time to remunerate its projectors.

“ DECIMUS BURTON.

“ ROBERT MARNOCK.”

If the sum now proposed to be raised were expended with little delay on the projected plan (see Design by Architect and Curator), the gardens might be so far completed as to offer by the month of May next (see Report) a most agreeable attraction to the public, and to decide at once the many who but wait for some demonstration of activity to become subscribers. For as no one hesitates to admit that a highly cultivated ornamental garden is a chief desideratum in this crowded metropolis, or that the spot selected for the one in question is in no respect surpassed ; so no one can doubt, that, of the numerous affluent inhabitants of London, there are sufficient anxious and ready to establish and maintain it. It is therefore hoped that, on consideration of

these circumstances, the present members will not fail to give their support to a measure which must insure the immediate success and prosperity of the Society.

J. D. C. SOWERBY, Secretary.

Offices, 49, Pall Mall, August 1. 1840.

The Plan, we understand, is being lithographed, and we shall probably be able to give some account of it in our next Number. — *Cond.*

ART. IV. *Mr. Main's Remarks on a Review of some of his Works which appeared in the "Athenæum."*

It is not my wish to make your pages an arena for literary squabbling ; but knowing your candour in admitting any civilly written remonstrance, especially from an individual who cannot demand or be allowed a reply in that quarter where he, as an author, has been traduced, I beg leave to trouble you with a short representation, the insertion of which among your miscellaneous matter will much oblige me.

In the *Athenæum* of April 25. page 330. I have been honoured by a nameless reviewer with notices of two of my little books, namely, *The Forest Pruner*, and *The Hand-book of Fruit Trees*. The first is spoken of in no measured terms of disparagement. The reviewer asserts that "its smallness and cheapness are its principal merits ; it is meagre, inaccurate, and its theory ridiculous."

These are severe accusations ; and, as coming from an awfully obscure and irresponsible source, are the more unjustifiable, as well to the author, as to his respectable publisher ; seeing that the reviewer does not condescend to adduce any proofs of the faults charged.

The brevity of the book was intentional ; because it should be cheap : and consequently meagre, because it would have been unfair to have puffed it out by transcription or quotation, which might have been easily done by repairing to Geneva or Paris, or to libraries nearer home. It may, indeed, be inaccurate in the language employed ; but, I venture to say, not in the practice it recommends. But the most tantalising charge, because so tauntingly made, is, that the theory is ridiculous ! Now, I really cannot perceive the gravamen of this charge ; and have been obliged to turn to the book to discover whether there be any such theorising observable. The only thing resembling theory, is my statement relative to the growth of the alburnum, and other new parts ; which, by the by, is only a statement of facts, of which any one may be convinced by the slightest observation. This statement, as well as that concerning the autumnal descent of the sap, it is true, does not accord with the opinions of the late T. A. Knight, Esq., President of the Horticultural Society of London, and others his followers, or rather his mere echoes. But it must be remembered that that most respectable authority abandoned some of his first impressions on these subjects ; and, moreover, was too acute an observer not to perceive that the cambium, so visible between the bark and the wood in summer, became alburnum in the autumn ; and too candid a writer not to have announced this discovery in some one of his published papers ; and which, indeed, has been quoted after him by at least one of his commentators. Unluckily, Mr. Knight did not follow out this sound and spontaneous conviction of his fertile mind, to account for the annual enlargement of the stem ; rather than attributing it to the "organisable" sap sent, or propelled, or invited, down from the leaves. Mr. Knight also proved that the sap of trees, withdrawn from the top or branches, is richer in essential qualities than that drawn from the base of the stem ; and that the fibrous attachments of a graft or inserted bud never descend below the junction with the stock ; both of which facts are antagonist to his ideas respecting the descent of the sap, or other descending processes of the plant, as assumed by him and others.

My questioning the validity of Mr. Knight's opinions on the first-mentioned particulars, appears to be the *ridiculous theory* which has called forth the re-

viewer's gratuitous condemnation; and yet my thanks are due for qualifying his severity by "damning with faint praise" a few grains of useful information which may be gleaned from the book. Still I cannot help *feeling* that my humble *name* has somehow or other been the cause of a descent of *elaborated gall* into my reviewer's ink; for the very next book reviewed, written by the same hand and pen, but *anonymous*, is spoken as highly of as the other is condemned! For this good turn I have of course to offer, on my own and publisher's behalf, our united thanks.

If my reviewer be a disciple of the Knightian school, and especially if he has avowed himself as such in public conversation, or as an expositor of vegetable phenomena, he certainly has some cause to complain of my representations, if they convey to his friends or his pupils any show of feasibility or of truth. Be this, however, as it may, it cannot be expected that practical men will suppress their own convictions, merely out of deference to those who happen to be seated in the high places of botanical society. — *J. Main. June 20. 1840.*

ART. V. *Retrospective Criticism.*

ERRATUM.—Page 264. line 14. for "King Pippin," read *Kerry Pippin.*

Mr. Main's Theory of Vegetable Developement. (p. 325.) — Mr. Lymburn's rejoinder is too candid and intellectual to be passed over or treated with silence. A very short reply, however, is only required, as it appears that different opinions are held merely from our lack of terms, or by the use of those which are undefined. There is always difficulty in explaining, or even conceiving infinity, whether of numbers or space. We can no more comprehend how infinite numbers can be contained in finite space, than we can measure immensity itself. But we usually judge of those things we do *not* know, by those we *do* know; and being assured no plant can originate itself; so neither can we conceive that any part of a plant can acquire identity without a preexisting rudiment.

In answer to Mr. Lymburn's last question, I have to reply, that a dicotyledonous stem is composed of four physical constituents; namely, the pith, the wood, and the bark: these three, being destitute of vitality after they are formed, produce neither buds nor roots; the other constituent lies between the wood and bark, that is, between the alburnum and liber, and is the vital membrane whence all buds and roots proceed. This living membrane is hardly visible during winter, being thin and colourless; but gradually becomes visible in summer, and changes to perfect timber in the autumn. Surely there can be no incomprehensibility about a fact like this, of which any one may be convinced by simple examination at the different seasons. — *J. Main. July 14. 1840.*

An Attempt to build in Lincoln's Inn Fields. — I trouble you with this at the instance of our good friend Mr. Ingpen. It seems there is a sacrilegious attempt about to be made to rob the city of London of one half of one of her finest squares, namely, Lincoln's Inn Fields, by an interested set of *Legal Vandals*, who wish to seize on this *breathing-place* for their new projected courts of law. The present courts in Westminster cost the country 100,000*l.*, which are to be demolished, or rendered useless, merely because many lawyers, and one or two of the judges, find it rather inconvenient to attend in Westminster; though they forget how inconvenient the new site would be to the crown lawyers who must attend the houses of parliament. Now, Sir, as you have always been an advocate for *opening*, rather than shutting up the few breathing-places so sparingly left in the city, pray do interpose with your pen to *prevent*, or *render odious*, such a wanton seizure of the very breath of heaven, and which is the undoubted property of the citizens. The beautiful trees which stand in the way of the new pile of bricks and mortar, must be sacrificed without mercy, lest they should ruffle the *dead wigs* of the selfish gowmsmen! — *J. Main. 3. Elm Terrace, Fulham Road, Aug. 13. 1840.*

Occurrences like that contemplated point out the necessity of what we have

always contended for; an authorised minister or commission to superintend all public changes in London and the suburbs; keeping in view convenience, health, and ornament, matters which at present are in a great measure left to chance. — *Concl.*

Ricauti's Rustic Architecture, reviewed p. 355. — In forwarding the third part of my work, entitled "Rustic Architecture, or the picturesque and pleasing Appearance of Rough Wood and Thatch, when applied as the only Decorations of Rural Buildings," I must certainly avail myself of the opportunity afforded by your kindness and liberality in allowing an author to do so, to correct one or two errors that have crept into the "Review" of Parts 1 and 2. In the first place, the number of plates is stated as being 147, whereas the whole work will be completed in 42 plates; these are divided into 6 parts, giving 7 plates for each design, as follows: — Part 1. A Peasant's Cottage, on a gentleman's estate; or for the accommodation of a very small family. Part 2. A Forester's Cottage; or for the residence of a small private family. Part 3. A Gamekeeper's Cottage; equally suited for the residence of a small family. Part 4. A Gardener's Cottage; or for the accommodation of a small family. Part 5. For the residence of a small genteel family; or a Bailiff's Cottage on a gentleman's estate. Part 6. For the residence of a genteel family; or a Steward's Cottage on a nobleman's estate.

I must also beg leave to state, that the sills, lintels, and reveals to the windows, &c., instead of being of "unbarked trees," are described in the specification as being "sawed out of old oak, or elm timber." This mode of construction was adopted to avoid the expense of stone dressings; and from the sheltered position of the doors, and the protection afforded to the windows by the projection of the thatch above, it will be seen that in most instances they are amply secured from the injurious effects of bad weather. But it is almost needless to observe that, if more strength and durability were required, the labels should be omitted, and the sills, lintels, and reveals formed of stone rudely hammer-dressed.

There is another error, of which I must decidedly acquit myself; and that is, of placing "stone mullions behind the rustic ones." The whole being formed of wood, and the rustic mullions fixed to them as shown in drawings. If brick or stone walls are objectionable on account of the incompatibility of the other material, both the designs may be executed entirely of rough timber, and lath and plaster roughcoated, as Design No. 3. The details of the framework, &c., are given to the scale of three quarters of an inch to a foot, plate 19. Part 3. — *S. J. Ricauti. 47. Great Russel Street, Bloomsbury, July 30. 1840.*

The Conical Boiler of Mr. Rogers. — In my last communication (p. 227.) on this subject, the form of a limekiln, or inverted cone, was suggested or hinted for future consideration; and as better than that of the upright cylinder as recommended by Mr. Beaton. The reason was, that, as the object in burning lime is to obtain the greatest extent of combustion with the smallest quantity of fuel, it might happen that the form universally used for that purpose might possibly supply the same result in one case as in the other, where the same object is to be attained. If there were no other objection than that made by Mr. Rogers, of the orifice at the lower extremity being liable to be choked by clinkers, &c., it might easily be remedied by a little attention in the construction; but I am satisfied, on consideration, that the objections to the inverted cone are of a much more serious nature. The reason is this: In burning lime, the object is to apply the principle of combustion equally, and gradually, over the mass of materials, chiefly towards the centre, and the sides are made consequently of non-conducting substances. In the present instance the focus is required to be at the bottom and sides, and removed from the centre, from the principle on which heat is received by the water, whilst the motion commencing at the bottom, the heat gradually ascends by the metallic surface, and escapes just as its power is no longer required by the diminution of the diameter of the boiler, and a great economy of fuel is the result. These reasons appear to me decisive as to the superiority of form of the cone, which has not im-

probably been hit on, without consideration of the principle on which it is founded. If this reasoning be correct, it is superior to every other form, and the only improvement it is capable of, is by considering and calculating the proportion of the cone, as it is too much to suppose that the best modification of it has been hit off at the first heat of the invention or application. I cannot help thinking that Mr. Rogers overrates the effect of friction in fixing his level, especially when you deduct the weight of the column to be raised perpendicularly to the upper or flowing point. However, it cannot be of very much importance either way. My observation only went to guard against the effects of the somewhat loose manner in which it was treated in his first paper.

In his courteous answer to my last note, Mr. Rogers has mistaken my meaning, which is of itself of little importance; but, as it may be of very grave consequence in bringing his excellent plan into general use, I will endeavour to correct it. The words of Mr. Rogers are: "With respect to the given quantity of water which any boiler would heat to boiling, a little reflection will, I think, show that it is a question not admitting a definite answer, and that, if answered, could lead to no practical result." I perfectly agree with Mr. Rogers, that such an enquiry would be loss of time, but my meaning was wholly different. So far from wishing to ascertain the quantity of water each boiler would *boil*, my object is to ascertain what quantity each would heat to 200°, or thereabouts, *BOILING being expressly guarded against* in my view of the case. It is very clear that there must be a limit to the capacity of each-sized boiler; and, assuming 200° as the best point of comparison, there would be no great difficulty in ascertaining how much each size would manage, when, by measuring the cooling surface of the house, it could be easily put in the power of any amateur or working gardener to estimate the size his house would require.

This very important point should be attended to either by the inventor or the manufacturer, and the hope of inducing them to do so, and consequently to enhance the value of this simple and excellent invention to the horticultural public, by extending its use, is the sole reason of my recurring to the subject.

I perfectly agree as to the greater friction of 2-inch pipes; on which account, as well as their being liable to choke from impurities of water, being more subject to defects in the casting, and the economy which appears to be their sole recommendation being trifling, they should probably be banished from any houses of importance. Of course the friction is very much augmented by elbows and turns, especially by descents to cross footways and the like. — *W.*

The Black Eagle Cherry. — I see that the Black Eagle Cherry, to which I gave a good character at p. 264., is denounced in strong terms by T. R. of Liverpool, at p. 375. The size of fruits must of course be estimated by comparison with others of the same class, and according to this rule I judged the cherry in question, making it a good-sized (that is, a *middle-sized*) fruit, intermediate between the small kinds, such as the Corone, and the large, like the Bigarreau. By referring to the Horticultural Society's *Fruit Catalogue*, I find my estimate of this cherry confirmed, for it is there classed with the May Duke, Kentish, and others, as a second or middle-sized fruit; it is, moreover, stated to be of the first quality, and as the account of its quality there given is the result of perhaps as much experience as T. R. can boast, many persons will have the hardihood to consider the author of that work the better authority of the two. I have myself grown the Black Eagle, and therefore am enabled flatly to contradict this libeller of cherries, who says that "a poorer, more rapid fruit was never produced." Either T. R. does not know the Black Eagle, or the inferiority of his fruit is the result of some defect in soil, situation, or management. — *J. B. W. July 8.*

THE
GARDENER'S MAGAZINE,
OCTOBER, 1840.

ORIGINAL COMMUNICATIONS.

ART. I. *The Derby Arboretum, founded by Joseph Strutt, Esq.: containing a Catalogue of the Trees and Shrubs, the History and Object of its Formation, the Reasons for the main Features of the Plan, and Directions for its future Management.* By the CONDUCTOR.

I. CATALOGUE OF THE TREES AND SHRUBS.

THE numbers which precede the names in this catalogue are those which precede the names on the brick tallies (*fig. 51.*), and their object is to facilitate the discovery of any species or variety which it may be wished to examine. The place of any plant in the Arboretum may be readily found by looking to the

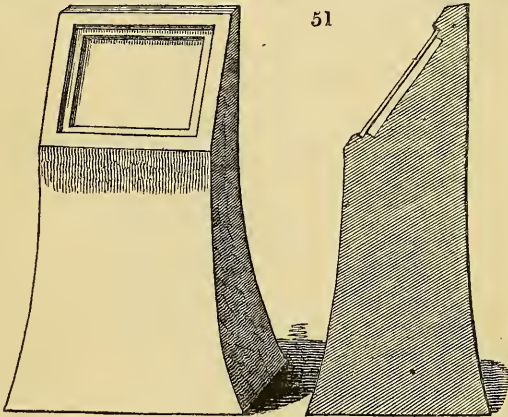

place of the nearest number in the ground plan, which forms the engraving *fig. 52.* For example, if it is desired to find the plant marked No. 26., find Nos. 20. and 30. on the plan, and No. 26. will be found between them in the grounds. The numbers and names, which commence with the plants of *Ranunculacææ*, begin at the right hand on entering the garden, are continued round it, and end with No. 802. on the left hand. Several plants have numbers followed by letters, as 16*a.*, 16*b.*, 16*c.*, &c. ; these merely show additions that were made after the first numeration was completed. These additions were made, partly because some plants were added which were at first thought too tender, and partly because some were obtained from the Horticultural Society's Garden, which it was thought could not be procured.

On the cards contained on the brick tallies (*fig. 51.*), the native country,
1840. Oct.

PLAN
OF THE
DERBY ARBORETUM,
1840.

- a North, or principal lodge, and entrance-gates.
- b South-east lodge and entrance.
- c, c Pavilions.
- d Flower-garden.
- e Cottage in the flower-garden.
- f Covered seat in the flower-garden.
- g Tool-house.
- h Arbour, covered with a large weeping ash.
- i Radiating centre, where a statue under a cupola is proposed.
- k Circle, shaded by some large trees, in the centre of which a pedestal and tazza vase are proposed to be placed.
- l Circle, surrounding a large white poplar.
- m Small pond.
- n, n, n Belt of miscellaneous plantation.

The Numbers are referred to in the Catalogue.



year of introduction, and height of the plant in its native country, are always given, as in *fig. 53.*, and therefore these are not repeated in this enumeration. An enlarged catalogue, containing descriptive or historical notices of all the remarkable species, is printed as a pamphlet of five or six sheets, and sold by the curator of the Arboretum; and in the public room of the curator's lodge a copy of the *Arboretum Britannicum* is kept for the use of gardeners and botanists who may wish to refer to it. The prices of the species, with a few exceptions, will be found in the list given in p. 73.

53

I.		
CLE'MATIS FLA'MMULA.		
THE INFLAMMATORY-JUICED		
CLEMATIS.		
FRANCE.	1596.	15 FT.

Ranunculàcææ.

- 1. to 11. CLE'MATIS L.
- 1. Flámmula L.
- 2. orientális L.
- 3. Vitálba L.
- 4. virginiána L.
- 5. triternáta Dec.
- 5a. gráta Wal.
- 6. flórida Thunb.
- 7. flórida flòre plèno Hort.
- 8. Viticélla cærúlea Hort.
- 9. Viticélla purpúrea Hort.
- 10. Viticélla múltiplex G. Don.
- 11. montána Ham.
- 12. and 13. ATRÁ'GENE L.
- 12. alpína L.
- 13. sibírica L.

- Pæoniàcææ.*
- 14. and 15. PÆO'NIA L.
- 14. Moútan papaveràcea And.
- 15. Moútan Bánksü And.
- 16. XANTHORHIZA apifólia L'Hérit.
- 16a. to 19b. MAGNO'LIA L.
- 16a. grandiflòra L.
- 16b. grandiflòra obovàta Ait.
- 16c. grandiflòra exoniénsis Hort.
- 16d. gláuca L.
- 16e. gláuca Thompsoniána Thomp.
- 16f. tripétala L.
- 17. acuminàta L.
- 18. (a.) cordàta Michx.

- 19. conspícua Salisb.
- 19a. purpúrea Sims.
- 19b. grácilis Hort.
- 20. LIRIODE'NDRON Tulipífera L.

Menispermåcææ.

- 21. MENISPERMUM canadénsis L.

Berberàcææ.

- 22. to 31a. BERBERIS L.
- 22. vulgàris L.
- 23. vulgàris álba Hort.
- 23a. vulgàris spathulàta Hort.
- 24. canadénsis Mill.
- 24a. emarginàta Willd.
- 25. ibérica Stev.
- 26. sinénsis Desf.
- 27. dúlcis Swt.
- 28. heterophýlla Juss.
- 29. empetrifólia Lam.
- 30. asiática Rox.
- 31. aristàta Dec.
- 31a. Wallichiana Dec.
- 32. to 33a. MAHO'NIA Nutt.
- 32. Aquifólius Nutt.
- 33. nervòsa Nutt.
- 33a. repens G. Don.

Cistàcææ.

- 33b. to 37. CISTUS L.
- 33b. villòsus Lam.
- 34. créticus L.
- 34a. álbidus L.
- 34b. salviæfólius L.
- 35. obtusifólius Swt.
- 36. corbariénsis Pourr.
- 36a. hirsútus Lam.
- 37. oblongifólius Swt.

- 38. to 49. HELIA'NTHEMUM Tourn.
- 38. canum Dunal.
- 39. cròceum Pers.
- 40. vulgàre Gært.
- 41. surrejànum Mill.
- 42. macránthum Swt.
- 43. macránthum flòre plèno Hort.
- 44. rhodánthum Dunal.
- 45. canéscens Swt.
- 46. mutábile Pers.
- 47. sulphúreum Willd.
- 48. venústum Swt.
- 49. Milleri Swt.

Malvåcææ.

- 50. to 54. HIBISCUS L.
- 50. syriacus fólis variegátis Hort.
- 51. syriacus flòre variegàto Hort.
- 52. syriacus flòre purpúreo Hort.
- 53. syriacus flòre rùbro Hort.
- 54. syriacus flòre álbo Hort.

Tiliàcææ.

- 55. to 61. TYLIA L.
- 55. europæ'a microphýlla Hort.
- 56. europæ'a platyphýlla Hort.
- 57. europæ'a rùbra Hort.
- 58. europæ'a laciniàta Hort.
- 59. europæ'a aúrea Hort.
- 59a. europ. álba Waldst. et Kù.
- 60. americàna L.
- 61. americàna pubéscens Hort.

Ternströmiaceæ.

62. MALACHODÉNDRON
ovatum Cav.
62a. STUARTIA virgí-
nica Cav.
62b. GORDONIA pubés-
cens Ph.

Hypericaceæ.

63. to 66. HYPERICUM
L.
63. elatum Ait.
64. hircinum L.
65. calycinum L.
66. prolificum L.
66a. ANDROSÆMUM
Chois.
66a. officinale Allioni.

Aceraceæ.

67. to 86. ACER L.
67. tataricum L.
68. spicatum L.
69. striatum L.
70. macrophyllum Ph.
71. platanoides L.
72. platanoides Lobèlii
Arb. Brit.
73. platanoides lacini-
atum Dec.
74. saccharinum L.
75. Pseudo-Plátanus L.
76. Pseudo-Plát. flavo
variegata Hort.
77. Pseudo-Plátanus
álbo variegata
Hayne.
78. Pseudo-Plátanus
purpurea Hort.
79. obtusatum Kit.
79a. (o.) Opalus Ait.
80. opulifolium Vill.
81. circinatum Pursh.
82. eriocarpum Michx.
83. rubrum L.
84. monspessulanum L.
85. campêtre L.
86. créticum L.
87. and 88. NEGUNDO
Mench.
87. fraxinifolium Nutt.
88. fraxinifolium crís-
pum G. Don.

Æsculaceæ.

89. to 95. ÆSCULUS L.
89. Hippocástanum L.

90. Hippocástanum va-
riegatum Hort.
91. (Hipp.) ohioënsis
Michx.
92. (H.) rubicúnda Lois.
93. (H.) glabra Willd.
94. (H.) pállida Willd.
95. (H.) Lyónii Hort.
96. to 104. PAVIA
Boerh.
96. rubra Lam.
97. rubra humilis Hort.
98. rubra humilis pén-
dula Hort.
99. flava Dec.
100. díscolor Swt.
101. hýbrida Dec.
102. neglécta G. Don.
103. macrocarpa Hort.
104. macrostachya Lois.

Sapinduceæ.

105. KÖLREUTE'RIA pa-
nícula Larm.

Vitaceæ.

106. to 109. VITIS L.
106. vinífera apiifolia
Hort.
107. Labrusca L.
108. cordifolia Michx.
109. riparia Michx.
110. to 112. AMPE-
LO'PSIS Michx.
110. hederacea Michx.
111. (h.) hirsuta Donn.
112. bipinnata Michx.

Xanthoxylaceæ.

113. XANTHOXYLUM
fraxineum Willd.
114. PTELEA trifoliata
L.
115. AILANTUS glandu-
lõsa Desf.

Coriaceæ.

116. CORIA'RIA myrtifõ-
lia L.

Staphyleaceæ.

117. and 118. STAPHY-
LEA L.
117. trifolia L.
118. pinnata L.

Celastraceæ.

119. to 124b. EUONY-
MUS Tourn.
119. europæus L.
120. europæus nanus
Lodd.
121. europæus fructu
álbo Lodd.
122. verrucosus Scop.
123. latifolius C. Bauh.
124. americanus L.
124a. japonicus Thunb.
124b. japonicus Hort.
125. CELASTRUS scán-
dens L.

Aquifoliaceæ.

126. to 137a. ILEX L.
126. Aquifolium hetero-
phyllum Hort.
126a. Aquifolium margi-
natum Hort.
126b. Aquifolium lauri-
folium Hort.
126c. Aquifolium ciliä-
tum Hort.
126d. Aquifolium ciliä-
tum minus Hort.
126e. Aquifolium recúr-
vum Hort.
127. Aquifolium crispum
Hort.
128. Aquifolium ferox
Hort.
128a. Aquifolium crassi-
folium Hort.
129. Aquifolium senés-
cens Sweet.
130. Aquifolium álbo-
marginatum Hrt.
131. Aquifolium aúreo-
marginatum Hrt.
132. Aquifolium aúreo-
píctum Hort.
133. Aquifolium ferox
argenteum Hort.
134. Aquifolium ferox
aúreum Hort.
135. Aquifolium fructu
luteo Hort.
136. baleárica Desf.
137. opaca Ait.
137a. Cassine Ait.
138. and 139. PRINOS
L.
138. decídus Dec.
139. verticillatus L.

Rhamnàcææ.

- 139a. *ZÍZYPHUS* vulgàris *Lam.*
 140. *PALIURUS* aculeàtus *Lam.*
 141. to 149. *RHÀMINUS* *Lam.*
 141. *Alatérnus* *L.*
 142. *Alatérnus* fòliis aúrcis.
 143. híbridus *L'Hérit.*
 144. cathárticus *L.*
 145. saxátilis *L.*
 146. *Erythróxylon* *Pall.*
 147. alpinus *L.*
 148. Frángula *L.*
 149. latifòlius *L'Hérit.*
 150. *CÉANO'THUS* americànus *L.*

Homalinàcææ.

- 150a. *ARISTOTÈLIA* *Macqui* *L'Hérit.*
 150b. *Máccui* fòliis variegàtis *Hort.*

Anacardiàcææ.

- 150c. and 150d. *PIS-TA'CIA* *L.*
 150c. *Lentiscus* *L.*
 150d. *Terebínthus* *L.*
 151. to 158. *RHU'S* *L.*
 151. *Cótinus*
 152. *typhina* *L.*
 153. glàbra *L.*
 154. glàbra coccínea.
 155. venenàta *Dec.*
 156. *radicans* *L.*
 157. *Toxicodéndron* *L.*
 158. *suavèolens* *Ait.*

Leguminàcææ.

159. and 160. *SOPHO'RA* *R. Br.*
 159. japónica *L.*
 160. japónica pèndula *Hort.*
 161. *VIRGÍLIA* lùtea *Michx.*
 162. to 164. *U'LEX* *L.*
 162. europæa *L.*
 163. europæa flòre plèno.
 163a. europæa nàna *Hort.*
 164. strícta *Mackay.*

165. *SPÀRTIUM* júnceum *L.*
 166. júnceum flòre plèno.
 166b. to 169. *GENÍSTA* *L.*
 166b. tríquetra *Ait.*
 167. lusitànica radiàta *Scop.*
 167a. tinctòria *L.*
 167b. tinctòria flòre plèno *Hort.*
 167c. sibírica *L.*
 168. prostràta *Lam.*
 169. procúbens *Waldst. et Kit.*
 170. to 184. *CYTISUS* *Dec.*
 170. álbus *Link.*
 171. álbus incarnàtus *Hort.*
 172. *Labúrnum* *L.*
 173. *Labúrnum* quercifòlium *Hort.*
 174. *Labúrnum* purpuràscens *Hort.*
 175. (*L.*) alpinus *Mill.*
 176. (*L.*) alpinus pèndulus.
 176a. *Wéldeni* *Vis.*
 177. nígricans *L.*
 178. sessilifòlius *L.*
 178a. scopàrius *Link.*
 178b. triflórus *L'Hérit.*
 178c. scopàrius fòliis variegàtis.
 179. scop. álbus *Hort.*
 179a. leucánthus *Waldst. et Kit.*
 179b. spinósus *Lam.*
 180. purpùreus *Scop.*
 180a. austriacus *L.*
 181. supíus *Jacq.*
 182. capitatus *Jacq.*
 183. polýtrichus *Bieb.*
 184. biflórus *L'Hérit.*
 185. *ADENOCA'RPUS* intermèdius *Dec.*
 186. *ONO'NIS* fruticòsa *L.*
 187. to 189. *AMO'RPHA* *L.*
 187. fruticòsa *L.*
 188. fruticòsa *Lewísii* *Lodd. Cat.*
 189. (*f.*) glàbra *Desf.*
 190. to 199. *ROBÍ'NIA* *L.*
 190. *Pseùd-Acàcia* *L.*

191. *Pseùd-Acàcia* umbraclifera *Dec.*
 192. *Pseùd-Acàcia* tortuòsa *Dec.*
 193. *Pseùd-Acàcia* *sophorafòlia* *Lodd. Cat.*
 194. *Pseùd-Acàcia* macrophýlla *Lo. C.*
 195. *Pseùd-Acàcia* microphýlla *Lo. C.*
 196. (*P.*) viscòsa *Vent.*
 197. híspida *L.*
 198. híspidaròsea *Pursh.*
 199. hísp. macrophýlla *Dec.*
 200. to 206. *CARAG'ANA* *Lam.*
 200. arboréscens *Lam.*
 201. (*a.*) *Altagàna* *Poir.*
 202. frutéscens *Dec.*
 203. pygmæa *Dec.*
 204. spinòsa *Dec.*
 205. *tracanthoides* *Poir.*
 206. *Chamlàgu* *Lam.*
 207. *HALIMODE'NDRON* argenteum *Dec.*
 208. *CALO'PHACA* wolgárica *Fisch.*
 209. and 210. *COLU'TEA* *R. Br.*
 209. arboréscens *L.*
 210. (*a.*) cruénta *Ait.*
 211. *CORONÍLLA* Eímèrus *L.*
 212. and 213. *WISTA'RIA* *Nutt.*
 212. frutéscens *Dec.*
 213. chinénsis *Dec.*
 214. to 218. *GLEDI'T-SCHIA* *L.*
 214. triacánthos *L.*
 215. sinénsis *Lam.*
 216. sinénsis purpùrea *Hort.*
 216a. inermis *Audibert.*
 217. (*s.*) fèrox *Desf.*
 218. cáspica *Desf.*
 219. *GYMNO'CLADUS* canadénsis *Lam.*
 220. *CÉ'RCIS* Siliquástum *L.*
 Rosàcææ.
 221. to 225. *AMY'GDA* *LUS* *Tourn.*
 221. nàna *L.*

222. communis amara *Dec.*
 223. communis dulcis *Dec.*
 224. communis macrocarpa *Ser.*
 225. orientalis *Ait.*
 226. PERSICA vulgaris flore pleno *Hort.*
 227. to 227a. ARME-
 NIACA *Tourn.*
 227. dasycarpa *Pers.*
 227a. (v.) sibirica *Pers.*
 228. to 230. PRUNUS
Tourn.
 228. spinosa flore pleno,
 229. domestica myrobala-
 lana *L.*
 230. maritima *Wangen-
 heim.*
 231. to 249. CERASUS
Juss.
 231. vulgaris flore pleno
Hort.
 232. vulgaris foliis varie-
 gatis *Hort.*
 232a. vulgaris *Marascha.*
 233. (v.) semperflorens
Dec.
 234. serrulata *G. Don.*
 235. Pseudo-Cerasus
Lindl.
 236. Chamæcerasus
Lois.
 237. prostrata *Ser.*
 238. depressa *Ph.*
 239. pygmaea *Lois.*
 240. nigra *Lois.*
 241. japonica *Lois.*
 242. japonica multiplex
Ser.
 243. Mahaleb *Mill.*
 244. Pædus *Dec.*
 245. Pædus bracteosa
Ser.
 246. virginiana *Michx.*
 247. lusitanica *Lois.*
 248. Laurocerasus *Lois.*
 249. Laurocerasus an-
 gustifolia *Hort.*
 250. and 251. KERRIA
 japonica *Dec.*
 251. japonica flore
 pleno.
 252. to 264a. SPIRÆA *L.*
 252. opulifolia *L.*
 253. chamædrifolia *L.*
 254. (c.) ulmifolia *Scop.*
 255. trilobata *L.*
 256. hypericifolia *Dec.*
 257. corymbosa *Raf.*
 258. bella *Sims.*
 259. salicifolia *L.*
 260. salicifolia panicu-
 lata *Willd.*
 261. tomentosa *L.*
 262. ariæfolia *Smith.*
 263. sorbifolia *L.*
 264. cuneifolia *Wall.*
 265. to 271. RUBUS *L.*
 265. laciniatus *W.*
 266. spectabilis *Ph.*
 267. fruticosus pompo-
 nius *Ser.*
 268. fruticosus foliis va-
 riegatis,
 269. fruticosus leuco-
 carpus *Ser.*
 270. odoratus *L.*
 271. nutkanus *Moc.*
 272. POTENTILLA fruti-
 ciosa *L.*
 273. to 284. ROSA
Tourn.
 273. ferox *Laur.*
 274. bracteata *Wendl.*
 275. cinnamomea *Best.*
 276. sulphurea *Ait.*
 277. spinosissima *L.*
 278. damascena *Mill.*
 279. centifolia *Lin.*
 280. villosa *L.*
 281. rubiginosa *L.*
 282. canina *L.*
 283. indica *L.*
 284. arvensis semper-
 virens *L.*
 284a. rubifolia *R. Br.*
 285. to 339a. CRATÆGUS
Lindl.
 285. coccinea *L.*
 286. coccinea corallina.
 287. coccinea indentata.
 288. coccinea maxima
Lodd.
 289. glandulosa *W.*
 290. glandulosa subvil-
 losa.
 291. punctata rubra
Pursh.
 292. punctata rubra
 stricta *Hort.*
 293. punctata aurea
Pursh.
 294. pyrifolia *Ait.*
 295. macracantha *Lodd.*
 296. Crús-gállí spléndens
Dec.
 297. Crús-gállí pyra-
 canthifolia *Dec.*
 298. Crús-gállí salicifolia
Dec.
 299. (C.) ovalifolia *Horn.*
 300. (C.) prunifolia *Bosc.*
 301. nigra *Waldst. et Kit.*
 302. purpurea *Bosc.*
 303. purpurea altaica
Arb. Brit.
 304. Douglàsii *Lindl.*
 305. flava *Ait.*
 306. (f.) lobata *Bosc.*
 307. trilobata *Lodd.*
 308. apiifolia *Michx.*
 309. apifol. minor *Hort.*
 310. cordata *Mill.*
 311. spathulata *Elliot.*
 312. Azaròus marocçana
Pers.
 313. Arònia *Bosc.*
 314. orientalis *Bosc.*
 315. orientalis sangui-
 nea *Hort.*
 316. tanacetifolia *Pers.*
 317. tanacetifolia glabra
Lodd.
 318. tanacetifolia Cels-
 iana *Dum.*
 319. heterophylla
Flugge.
 320. Oxyacantha obtu-
 sata *Dec.*
 320a. Oxyacantha quer-
 cifolia *Booth.*
 321. Oxyacantha laci-
 niata *Hort.*
 322. Oxyacantha erio-
 carpa *Lindl.*
 323. Oxyacantha Oliver-
 iana.
 324. Oxyacantha mel-
 nocarpa.
 325. Oxyacantha aurea
Hort.
 326. Oxyacantha múlti-
 plex *Hort.*
 327. Oxyacantha rosea
Hort.
 328. Oxyacantha puni-
 cea *Lodd.*
 329. Oxyacantha puni-
 cea fl. pl. *Hort.*
 330. Oxyacantha foliis
 argenteis *Hort.*
 331. Oxyacantha stricta
Lodd.
 332. Oxyacantha reginæ
Hort.

333. *Oxyacantha præcox Hort.*
 334. *Oxyacantha monogyne Hort.*
 335. *Oxyacantha apétala Lodd.*
 336. *parvifolia Ait.*
 337. *fúscá Jacq.*
 338. *mexicàna Moc. et Sesse.*
 339. *Pyracantha Pers.*
 339a. *Pyracantha crenulata Hort.*
 340. to 348. *COTONEASTER Med.*
 340. *vulgàris Lindl.*
 341. (vulg.) *tomentosa Lindl.*
 342. (v.) *laxiflora Jacq.*
 343. *frígida Wall.*
 344. (f.) *affinis Lindl.*
 345. *acuminata Lindl.*
 346. *Nummulària Lindl.*
 347. *rotundifolia Wall.*
 348. (rot.) *microphýlla Wall.*
 349. to 353. *AMELANCHIER Med.*
 349. (vul.) *Botryàpium Dec.*
 350. (v.) *sanguínea Dec.*
 351. (v.) *ovalis Dec.*
 352. (v.) *flórída Lindl.*
 353. (v.) *flórída parvifolia Hort.*
 354, 355. *ME'SPILUS Lindl.*
 354. *germànica L.*
 355. *Smithii Dec.*
 356. to 386. *PYRUS Lindl.*
 356. *communis fòl. variegàtis Hort.*
 357. *nivàlis L.*
 358. (c.) *salicifolia L.*
 359. (c.) *amygdalifórmis Vil.*
 360. *sinénsis Lindl.*
 361. *bollwylleriàna Dec.*
 362. *variolosa Wall.*
 363. (*M.*) *prunifolia W.*
 364. (*M.*) *baccàta L.*
 365. *coronària L.*
 366. *spectàbilis Ait.*
 367. *Aria Ehrh.*
 368. (*Aria*) *intermèdia Ehrh*
 369. (*A.*) *intermèdia latifolia Dec.*
 370. (*A.*) *vestita Wall.*
 371. *torminàlis Ehrh.*
 372. *rivulàris Doug.*
 373. *pinnatifida Ehrh.*
 374. *aucupària Gærtn.*
 375. *americàna Dec.*
 376. *Sórbus Gærtn.*
 377. *lanuginosa Dec.*
 378. *spùria Dec.*
 379. *spù. pèndula Hort.*
 380. *arbutifolia L.*
 381. *arbutifolia serótina Lindl.*
 382. (arbut.) *floribunda Lindl.*
 383. (a.) *deprèssa Lindl.*
 384. *pùbens Lindl.*
 385. *grandifolia Lindl.*
 386. *Chamàmèspilus Lindl.*
 387. to 390. *CYDONIA Tourn.*
 387. *vulgàris pyrifórmis Hort.*
 388. *sinénsis Thouin.*
 389. *japónica Pers.*
 390. *japónica flòre álbo Hort.*
- Calycanthaceæ.*
391. *CALYCAN'THUS flóridus L.*
 392. and 393. *CHIMONANTHUS fragrans Lindl.*
 393. *fragrans lùteus Hort.*
- Tamaricaceæ.*
394. *TAMARIX gallica L.*
 395. *MYRICARIA germanica Desv.*
- Philadelphaceæ.*
396. to 403a. *PHILADELPHUS L.*
 396. *coronàrius L.*
 397. *coronàrius flòre plèno Lodd.*
 398. *coronàrius variegatus Lodd.*
 399. *verrucosus Schrad.*
 400. (v.) *latifolius Schr.*
 401. *laxus Schrad.*
 402. (lax.) *grandiflorus Willd.*
 403. *hirsutus Nutt.*
- 403a. *Gordonianus Lind.*
 403b. *speciosus Wall.*
 404. *DEUTZIA scàbra Thunb.*
- Grossulacæ.*
405. to 430. *RIBES L.*
 405. *setosum Lindl.*
 406. *triflorum W.*
 407. (t.) *niveum Lindl.*
 408. (t.) *Cynósbatì L.*
 409. (t.) *divaricatum Dougl.*
 410. *speciosum Pursh.*
 411. *Diacantha L. fil.*
 412. *lacustre Poir.*
 413. *rubrum variegatum Dec.*
 414. (r.) *alpinum L.*
 415. (r.) *petraeum Wulf.*
 416. (rub.) *multiflorum Kit.*
 417. *punctatum R. et P.*
 417a. *nigrum bácca viride Hort.*
 418. *nigrum fòliis variegatis Vilmorin.*
 419. (n.) *triste Pall.*
 420. (nigrum) *floridum L'Hérit.*
 421. (n.) *floridum grandiflorum Hort.*
 422. *cereum Dougl.*
 423. *sanguineum Pursh.*
 424. *sanguineum glutinosum Benth.*
 425. *sanguineum malvaceum Benth.*
 426. *sanguineum atrorubens Hort.*
 427. *aureum præcox Lindl.*
 428. *aureum serotinum Lindl.*
 429. (aur.) *tenuiflorum Lindl.*
 430. (aur.) *flavum Coll.*
- Escalloniaceæ.*
431. *ITEA virginica L.*
- Saxifrageæ.*
432. to 433a. *HYDRANGEA L.*
 432. *arborescens L.*
 433. *nivea Michx.*
 433a. *quercifolia Bartram.*

Araliàceæ.

434. and 434a. *ARA'LIA*
L.
434. *spinòsa L.*
434a. *japónica.*
435. to 437. *HE'DERA*
Swartz.
435. *Hèlix vulgàris Dec.*
436. *Hèlix canariénsis*
Dec.
437. *Hèlix fòliis argén-*
teis Lodd.

Hamamelidàceæ.

438. *HAMAME'LIS virgi-*
nica L.
439. *FOTHERG'ILLA alni-*
fòlia L.

Cornàceæ.

440. to 447. *CO'RNU'S L.*
440. *alternifòlia L.*
441. *sanguínea L.*
442. *sanguínea fòliis va-*
riegàtis.
443. *álba L.*
444. *álba sibírica Lodd.*
445. (a.) *stricta Lam.*
446. *circinàta L'Hérit.*
447. *más L.*

Loranthàceæ.

448. *VÍSCUM álbum L.*
449. *AU'CUBA japónica*
Thunb.

Caprifoliàceæ.

450. to 453. *SAMBU'CUS*
Tourn.
450. *nigra L.*
451. *nigra leucocárpa*
Hort.
452. *nigra laciniàta.*
453. *racemòsa L.*
454. to 461. *VIBU'RNUM*
L.
454. *Tínus L.*
455. *Tínus lúcida Ait.*
456. *Tínus stricta Hort.*
457. *Lentágo L.*
458. (L.) *prunifòlium L.*
459. (*cassinòides*) *lævi-*
gátum Willd.
460. *dentátum L.*
461. *O'pulus stérilis*
Dec.

462. *DIERVÍ'LLA cana-*
dénsis Willd.
463. to 472. *LONI'CERA*
Desf.
463. *Periclýmenum se-*
rótinum Ait.
464. *Periclýmenum bél-*
gicum Hort.
465. *Periclýmenum*
quercifòlium Ait.
466. *gràta Ait.*
467. *tatárica L.*
468. *tatárica rubriflòra*
Dec.

469. *pyrenàica L.*
470. *alpígena L.*
471. *cærúlea L.*
472. *ibérica Bieb.*
473. to 475a. *SYMPHO-*
RICA'RPOS Dill.
473. *vulgàris Michx.*
474. *vulgàris fòliis varie-*
gàtis Hort.
475. *racemòsus Michx.*
475a. *montànus Arb.*
Brit.
475b. *LEYCESTE'RIA*
formòsa Wall.

Rubiàceæ.

476. *CEPHALA'NTHUS*
occidentàlis L.

Compòsitæ.

477. *BA'CCHARIS hali-*
misfòlia L.
478. and 479. *ARTE-*
MÍ'SIA Cass.
478. *Abrótanum L.*
479. *Abrótanum tobol-*
skiànnum Hort.

Ericàceæ.

480. to 485. *ERÍ'CA D.*
Don.
480. *Tétralix cárnea*
Hort.
481. *Tétralix álba Hort.*
Eric. Wob.
482. *cinèrea L.*
483. *cinèrea atropur-*
pùrea Lodd.
484. *cinèrea álba Lodd.*
485. *ciliàris L.*
486. and 487. *GYPSo-*
CA'LLIS Sal.
486. *vàgans Sal.*
487. *cárnea D. Don.*

488. to 491. *CALLU'NA*
Sal.
488. *vulgàris decumbens*
Don's Mill.
489. *vulgàris flòre plèno*
Don's Mill.
490. *vulgàris fòliis varie-*
gàtis Don's Mill.
491. *vulgàris coccínea*
Don's Mill.
492. *CASSA'NDRA caly-*
culàta nàna Sims.
493. and 494. *ZENO'BIA*
D. Don.
493. *speciòsa D. Don.*
494. *speciòsa pulveru-*
lènta Pursh.
495. *LEUCO'THOE spín-*
ulòsa G. Don.
496. and 497. *DABCE'CIA*
D. Don.
496. *polifòlia D. Don.*
497. *polif. fl. álbo Swt.*
498. to 503. *ARBUS*
Camer.
498. *U'nedo L.*
499. *U'nedo rùber Ait.*
500. *U'nedo plènus Ait.*
501. *hýbrida Ker.*
502. *Andráchne L.*
503. *procèra Douglas.*
504. *ARCTOSTA'PHYLOS*
U'va-úrssi Spreng.
505. *PERNET'TYA mu-*
cronàta Gaud.
506. *GAULTHE'RIA*
Shállon Pursh.
507. *CLE'THRA alnifòlia*
L.
508. to 516. *RHODO-*
DE'NDRON L.
508. *pónticum L.*
508a. *pónticum Smíthii*
Swt.
508b. *pónticum azaleo-*
ides Hort.
509. *máximum L.*
509a. (m.) *purpùream*
G. Don.
510. *catawbiènsè Michx.*
511. *punctátum Andr.*
512. *ferrugíneum L.*
512a. (f.) *hirsútum L.*
512b. *dàuricum L.*
513. *flàvum G. Don.*
514. *nudiflòrum coccí-*
neum D. Don.
515. *viscòsum Torr.*
516. *Rhodòra G. Don.*

517. and 518. *KALMIA*
L.
517. latifolia L.
518. glauca Ait.
519. *MENZIESIA* globu-
laris Salisb.
520. *AZALEA* procum-
bens L.
521. *LEDUM* palustre L.
521a. to 525. *VACCINI-
UM* L.
521a. Myrtillus L.
521b. caespitosum Michx.
522. resinosum Ait.
523. *Arctostaphylos* L.
523a. (A?) padifolium
Sm.
524. *Vitis* idæa L.
525. ovatum Pursh.
526. *OXYCOCUS* ma-
crocarpus Pursh

Halesiæcæ.
527. and 528. *HALESIA*
Ellis.
527. tetraptera L.
528. diptera L.

Ebenæcæ.
529. and 530. *DIOS-
PYROS* L.
529. Lotus L.
530. virginiana L.

Oleæcæ.
531. and 532. *LIGUS-
TRUM* Tourn.
531. vulgare Trag.
532. vulgare leucocar-
pum Hort.
533. to 534c. *PHIL-
LYREA* Tourn.
533. angustifolia L.
533a. angustifolia lan-
ceolata Ait.
533b. angustifolia bra-
chiata Ait.
533c. (media) ligustrifò-
lia Ait.
534. (m.) latifolia L.
534a. (m.) lævis Ait.
534b. (m.) obliqua Ait.
534c. (m.) spinosa Mill.
535. *CHIONANTHUS* vir-
ginica L.
536. to 542. *SYRINGAL.*
536. vulgàris L.
537. vulgàris álba Hort.

538. *Josikæa* Jacq.
539. pérsica L.
540. pérsica álba Lodd.
Cat.
541. pérsica laciniata
Lodd. Cat.
542. rothomagensis Re-
nault.
543. *FONTANE'SIA* phil-
lyreoides Labill.
543a. to 558. *FRA'XI-
NUS* Tourn.
543a. excelsior L.
544. excelsior aúrea
Willd.
545. excelsior crísipa
Hort.
546. excelsior verrucòsa
Desf.
547. excelsior nàna
Lodd. Cat.
548. (e.) heterophýlla
Vahl.
549. (e.) parvifolia Willd.
549a. (e.p.) oxycarpa
Willd.
550. lentiscifolia Desf.
551. lentiscifolia pén-
dula Hort.
552. (americana) pubés-
cens Walt.
553. (a.) sambucifolia
Vahl.
554. (a.) quadrangulata
Michx.
555. (a.) juglandifolia
Lam.
556. (a.) eiptera Vahl.
557. (a.) ovata Bosc.
558. (a.) pannosa Vent.
et Bosc.
559. and 560. *O'RNUS*
Pers.
559. europæa Pers.
560. rotundifolia Pers.
561. to 563. *JASMINUM*
Forskoel.
561. fruticans L.
562. humile L.
563. officinale L.

Apocynæcæ.
564. and 565. *VI'NCA* L.
564. mājor L.
565. minor L.

Asclepiadæcæ.
566. *PERI'PLOCA* græca
L.

Bignoniæcæ.

567. *CATA'LPA* syringæ-
folia Sims.

Solanæcæ.

568. and 568a. *LY'CIUM*
L.
568. (e.) bárbarum L.
568a. (e.) ruthenicum
Murr.

Chenopodiæcæ.

569. *A'TRIPLEX* portu-
lacoides L.

Lauræcæ.

570. to 571. *LAU'RUS*
Plin.
570. nóbilis L.
570a. nóbilis salicifolia
Swit.
570b. *Sassafras* L.
571. *Benzoin* L.

Thymelæcæ.

572. to 576a. *DA'PHNE*
L.
572. *Mezereum* L.
573. *Mezereum* flore
álbo Hort.
574. *Mezereum* autum-
nàle Hort.
575. póntica L.
576. *Cneorum* L.
576a. Aucklándi Hort.
577. *DI'RCA* palústris L.

Santalæcæ.

578. *NY'SSA* biflora
Michx.

Elæagnæcæ.

579. and 580. *ELÆA'G-
NUS* Tourn.
579. horténsis Bieb.
580. horténsis angusti-
folia Bieb.
581. and 582. *HIPPO'-
PHAE* L.
581. *Rhamnoides* L.
582. salicifolia D. Don.
583. and 584. *SHEP-
HER'DIA* Nutt.
583. argéntea Nutt.
584. canadénsis Nutt.

- Aristolochidææ.*
 585. ARISTOLO`CHIA siphon L'Hérit.
- Euphorbiææ.*
 586. to 588. BU`XUS Tourn.
 586. sempervirens arborescens Mil. Dic.
 587. sempervirens arborescens marginata Hort.
 588. sempervirens myrtifolia Lam.
 588a. baleárica Willd.
- Urticææ.*
 589. to 591. MO`RUS Tourn.
 589. nigra Poir.
 590. álba L.
 591. álba Morrettiana Hort.
 592. BROUSSONE`TIA papyrifera Vent.
 593. MACLU`RA aurantiaca Nutt.
 593a. FI`CUS Cárica.
 594. BO`RYA ligustrina Willd.
- Ulmææ.*
 595. to 614. U`LMUS L.
 595. campéstris L.
 596. campéstris álba Masters.
 597. campéstris acutifolia Masters.
 598. campéstris stricta Hort. Dur.
 599. campéstris virens Hort.
 600. campéstris viminalis Masters.
 601. suberosa vulgáris Hort.
 602. suberosa foliis variegatis Lod. Cat.
 603. suberosa álba Hort.
 604. montana Bauh.
 605. montana rugosa Masters.
 606. montana major Masters.
 607. montana minor Masters.
 608. montana péndula Hort.
609. montana fastigiata Hort.
 610. montana crispa Hort.
 611. glabra vegèta Hort.
 612. glabra major Hort.
 613. glabra péndula.
 614. americana L.
 615. PLA`NERA Richárdi Michx.
 615a. to 618. CE`LTIS Tourn.
 615a. caucásica Willd.
 616. occidentalis L.
 617. occidentalis cordata Willd.
 618. crassifolia Lam.
- Juglandææ.*
 619. to 621. JU`GLANS L.
 619. régia L.
 620. nigra L.
 621. cinerea L.
 622. to 624. CA`RYA Nutt.
 622. amara Nutt.
 623. álba Nutt.
 624. porcina Nutt.
 624a. PTEROCA`RYA caucásica Kunth.
- Salicææ.*
 625. to 655. SA`LIX L.
 625. purpurea mas L.
 626. purpurea fem. L.
 627. hélix mas L.
 628. hélix fem. L.
 629. Lambertiana Sm.
 630. Woollgariána Bor.
 631. Forbyána Sm.
 632. triándra mas L.
 633. triándra fem. L.
 634. pentándra L.
 635. Meyeriána Willd.
 636. babylónica fem. L.
 637. babylónica crispa Hort.
 638. decípiens mas Hoffm.
 639. decípiens fem. Hoffm.
 640. frágilis mas. L.
 641. frágilis fem. L.
 642. Russelliána mas Sm.
 643. Russelliána fem. Sm.
 644. álba L.
645. álba cærúlea Hort.
 646. vitellina mas L.
 647. vitellina fem. L.
 648. nigra Mühlenb.
 649. acuminata Sm.
 650. Pontederána Willd.
 651. cinerea L.
 652. aurita L.
 653. caprea L.
 654. nigricans Sm.
 655. laurina Sm.
 656. to 667. PO`PULUS Tourn.
 656. álba L.
 657. trémula péndula Hort.
 658. græ`ca Ait.
 659. nigra L.
 660. nigra salicifolia Hort.
 661. monilífera mas Ait.
 662. monilífera fem. Ait.
 663. monilífera Lindleyana Booth.
 664. fastigiata mas.
 665. heterophýlla L.
 666. balsamífera L.
 667. cándicans Ait.
- Betulææ.*
 668. to 678b. A`LNUS Tourn.
 668. glutinosa Gærtn.
 669. glutinosa laciniata Willd.
 670. glutinosa quercifolia Willd.
 671. glutinosa oxyacanthæfolia Hort.
 672. oblongata Willd.
 673. oblongata foliis ellipticis Ait.
 674. incana Willd.
 675. incana laciniata Lodd. Cat.
 676. serrulata Willd.
 677. cordifolia Lodd.
 678. víridis Dec.
 678a. barbata C. A. Meyer.
 678b. subcordata C. A. Meyer.
 679. to 689. BE`TULA Tourn.
 679. álba L.
 680. álba péndula Sm.
 681. álba póntica Hort.
 682. álba urticifolia Hort.

683. pùmila L.
 684. nàna L.
 685. populifòlia Ait.
 686. populifòlia laciniàta Hort.
 687. papyràcea Ait.
 688. nigra L.
 689. lénta L.
Corylàceæ, or Cupuliferæ.
 689a. to 715. QUE'RCUS L.
 689a. pedunculàta Willd.
 690. pedunculàta fastigiàta Arb. Brit.
 691. pedunculàta heterophýlla Hort.
 692. pedunculàta fòliis variegàtis Lod. C.
 693. pedunculàta purpùrea Hort.
 694. sessilifòra Sal.
 695. pyrenàica Willd.
 696. É'sculus L.
 697. Cérris L.
 698. Cérris variegàta Lodd. Cat.
 699. Cérris austriaca Hort.
 700. Cérris fulhaménsis Hort.
 701. Cérris Lucombeàna.
 702. Æ'gilops L.
 703. Æ'gilops péndula Hort.
 704. álba L.
 705. macrocarpa Willd.
 706. Prìnus L.
 707. rùbra L.
 708. coccínea Willd.
 709. palústris Willd.
 710. Phéllos L.
 711. Flex L.
 712. gramúntia L.
 713. coccifera L.
 714. Sìber L.
 715. Túrneri Willd.
 716. to 721. FA'GUS L.
 716. sylvática L.
 717. sylvática purpùrea Ait.
 718. sylvática fòliis variegàtis Lod. C.
 719. sylvática heterophýlla.
 720. sylvática cristàta Lodd. Cat.
 721. sylvática péndula Lodd. Cat.
 722. to 724. CASTA'NEA Tourn.
 722. véscia Gærtn.
 723. véscia asplenifòlia Lodd. Cat.
 724. véscia variegàta Hort.
 725. and 726. CA'RPINUS L.
 725. Bétulus L.
 726. (B.) americàna Michx.
 727. and 728. O'STRYA Willd.
 727. vulgàris Willd.
 728. (v.) virgínica Willd.
 728a. to 732. CO RYLUS L.
 728a. Avellàna L.
 729. Avellàna heterophýlla Hort.
 730. Avellàna purpùrea Hort.
 731. Colúrna L.
 732. rostràta Ait.
Garryàceæ.
 733. GA'RRYA elliptica Doug.
Platanàceæ.
 734. to 735. PLA'TANUS L.
 734. orientàlis L.
 735. occidentàlis L.
Balsamàceæ.
 736. and 737. LIQUI'DA'MBAR L.
 736. Styracífua L.
 737. imbérbe Willd.
Myricàceæ.
 738. MYRICA Gåle L.
 739. COMPTONIA asplenifòlia Banks.
Gnetàceæ.
 740. E'PHEDRA distàchya L.
Taxàceæ.
 741. to 743. TA'XUS L.
 741. baccàta L.
 742. b. fastigiàta Hort.
 743. (b.) canadénsis W.
 744. and 745. SALIS-BU'RIA.
 744. adiantifòlia mas Sm.
 745. adiantifòlia fem. Sm.
Coníferæ, or Pinàceæ.
 746. to 756a. PINUS L.
 746. sylvéstris L.
 746a. sylvéstris horizontàlis Hort.
 746b. sylvéstris uncinàta Don of Forfar.
 747. (s.) pumílio Hænke.
 748. pumílio Mùghus Hort.
 749. inops Ait.
 750. Lárcio Poir.
 751. (L.) austriaca Hòss.
 752. (L.) Pallasiana Lamb.
 753. Pinàster Ait.
 753a. Pinàster marítimus Hort.
 754. Pínea L.
 754a. halepénsis Ait.
 754b. brùtia Ten.
 754c. Sabiniana Doug.
 754d. insignis Doug.
 754e. Llaveàna Otto.
 755. Cembra L.
 756. Stròbus L.
 756a. (S.) excélsa Wallich.
 757. to 762. ABIES D. Don.
 757. excélsa Dec.
 758. excélsa Clanbrasilàna Hort.
 759. álba Michx.
 760. nigra Ait.
 761. Smithiana Wall.
 761a. Douglàsü Lindl.
 762. canadénsis L.
 763. to 764a. PR'CEA D. Don.
 763. pectinàta.
 763a. Píchta.
 763b. cephalónica Arb. Brit.
 763c. Pínsapo Arb. Brit.
 764. balsàma L.
 764a. religiòsa H. et K.
 765. to 765a. LA'RIX Tourn.
 765. europæa Dec.
 765a. e. sibérica Hort.
 766. and 766a. CE'DRUS Barrel.

- | | | |
|--------------------------|---------------------------|---------------------------|
| 766. Libani Barr. | 775. to 785. JUNI'PERUS | <i>Smilacææ.</i> |
| 766a. Deodara Roxb. | L. | 788. to 794. SMI'LAX L. |
| 766b. ARAUCA'RIA im- | 775. communis L. | 788. áspera L. |
| briçata Pav. | 776. c. suécica Mart. | 789. excélsa L. |
| 767. to 769. THU'JA L. | 777. c. nàna Willd. | 790. Sarsaparilla L. |
| 767. occidentális L. | 778. virginiana L. | 791. rotundifolia L. |
| 768. orientális L. | 779. Sabina L. | 792. tamnòides L. |
| 769. orientális tatárica | 780. Sabina tamarisci- | 793. caduca L. |
| Hort. | fòlia Ait. | 794. virginiana Mill. |
| 770. to 772c. CUPRE'S- | 781. S. fòllis variegàtis | |
| sus L. | Mart. | <i>Liliacææ.</i> |
| 770. sempervirens L. | 782. S. prostrata Hort. | 795. to 797. RU'SCUS L. |
| 771. sempervirens hori- | 783. phœncea L. | 795. aculeatus L. |
| zontális Mil.Dic. | 783a. (p.) lycia L. | 796 (hypophýllum) Hy- |
| 772. thyòides L. | 783b. excélsa Willd. | poglóssum L. |
| 772a. torulosa Lamb. | 784. recurva Ham. | 797. racemosus L. |
| 772b. expansa Audibert. | 785. chinensis L. | 798. to 802. YU'CCA L. |
| 772c. Tournefortii Aud. | <i>Empetrææ.</i> | 798. gloriòsa L. |
| 773. and 774. TAXO'DI- | 786. EMPETRUM nigrum | 799. stricta Sims. |
| UM Rich. | L. | 800. recurvifolia Salisb. |
| 773. dístichum Rich. | 787. CORE'MA álba D. | 801. flaccida Haw. |
| 774. dístichum sinense | Don. | 802. crenulata Hort. |
| péndulum Hort. | | |

The supplementary species added since the list was first made out, and which have letters after the numbers, amount to 111, which makes the total number of species and varieties contained in the Arboretum 913; or, with the addition of the 100 sorts of roses planted in the belt, 1013.

II. HISTORY AND PROPOSED MANAGEMENT.

In giving a brief outline of the history of the formation of the Derby Arboretum, and of the manner in which I think it ought to be managed afterwards, I shall first notice the object in view in forming the garden, its situation, and the instructions on which I proceeded in forming the design; next, my reasons for its main features; and, thirdly, an outline of what I propose should be its future management.

THE OBJECT IN VIEW, SITUATION, AND INSTRUCTIONS.

The subject to be created is a public garden of recreation for the general population of the town of Derby. It is to be formed on a certain piece of ground, the property of Joseph Strutt, Esq., and completed at his expense; afterwards, the whole is to be presented by that gentleman to the Corporation of Derby, on certain conditions, and to be kept up at their expense.

The situation is in the outskirts of the town; the extent about 11 acres; the form long, narrow, and irregular, as shown by the plan, *fig. 52.*; the surface is flat, apparently level, but with a very gentle inclination from the north-east to the south-west; and the soil is loamy, on a gravelly or loamy subsoil. The situation is open, but not much exposed to high winds; water is to be found at the usual depth to which wells are dug, and there is one small pond which is never dry at any period of the year. Every part of the ground admits of drainage; but all the drains must terminate at the south-east corner, where alone the water can escape. The soil is particularly well adapted for the growth of trees, as is evident from the belt which surrounds great part of the grounds, and which was planted some years ago by Mr. Strutt. The most important feature in this piece of ground, with reference to its adaptation for a garden of recreation, is, that there is no distant prospect, or view beyond the grounds, worthy of being taken into consideration in laying them out; or at least none that may not, in a very few years, be shut out by the buildings of the town, which are increasing fast on every side.

The instructions given to me by Mr. Strutt respecting laying out this piece of ground were, that the garden was intended to be one of recreation for the inhabitants of Derby and the neighbourhood, and for all other persons who chose to come and see it ; that it should be open two days in the week, and that one of these days should be Sunday, during proper hours ; and that on other days a small sum should be required from persons entering the garden ; or yearly admissions should be granted for certain moderate sums. That the gardens should be so laid out and arranged as not to be expensive to keep up ; that a flower-garden and cottage, with the plantations already existing, should, if possible, be preserved ; that a tool-house covered with ivy should also be preserved ; that two lodges with gates, at the two extremities, should be built ; and that each lodge should have a room, to be considered as a public room, into which strangers might go and sit down, taking their own refreshments with them, without any charge being made by the occupant of the lodge, unless some assistance, such as hot water, plates, knives and forks, &c., were required, in which case a small voluntary gratuity might be given. That there should be proper yards and conveniences at each lodge for the use of the public, apart from those to be exclusively used by the occupant of the lodge. That there should be open spaces in two or more parts of the garden, in which large tents might be pitched, a band of music placed, dancing carried on, &c. That certain vases and pedestals now in the flower-garden, and also certain others in Mr. Strutt's garden in Derby, should be retained or introduced ; and, finally, that some directions should be left for the management of the garden.

REASONS FOR THE MAIN FEATURES OF THE PLAN.

In endeavouring to accommodate the design submitted to Mr. Strutt to his instructions and to the situation, the first point determined on was, that the whole interest of the garden should be contained within itself. The mode of doing this was next to be considered ; when it appeared that a general botanic garden would be too expensive, both to create and to keep up ; that a mere composition of trees and shrubs with turf, in the manner of a common pleasure-ground, would become insipid after being seen two or three times ; and, in short, that the most suitable kind of public garden, for all the circumstances included in the above data, was an arboretum, or collection of trees and shrubs, foreign and indigenous, which would endure the open air in the climate of Derby, with the names placed to each. Such a collection will have all the ordinary beauties of a pleasure-ground viewed as a whole ; and yet, from no tree or shrub occurring twice in the whole collection, and from the name of every tree and shrub being placed against it, an inducement is held out for those who walk in the garden to take an interest in the name and history of each species, its uses in this country or in other countries, its appearance at different seasons of the year, and the various associations connected with it.

A similar interest might, no doubt, have been created by a collection of herbaceous plants ; but this collection, to be effective in such a space of ground, must have amounted to at least 5000 species ; and to form such a collection, and keep it up, would have been much more expensive than forming the most complete collection of trees and shrubs that can at present be made in Britain. It is further to be observed respecting a collection of herbaceous plants, that it would have presented no beauty or interest whatever during the winter season ; whereas, among trees and shrubs, there are all the evergreen kinds, which are more beautiful in winter than in summer ; while the deciduous kinds, at that season, show an endless variety in the ramification of their branches and spray, the colour of their bark, and the colour and form of their buds. Add also, that trees and shrubs, and especially evergreens, give shelter and encouragement to singing birds, to which herbaceous plants offer little or no shelter or food.

There are yet other arguments in favour of trees and shrubs for a garden of recreation, which are worth notice. Herbaceous plants are low, small, and

to have any effect must be numerous ; while, to acquire their names, and look into their beauties, persons walking in the garden must stand still, and stoop down, which, when repeated several times, would soon, instead of a recreation, become very fatiguing. Now trees and shrubs are large objects, and there is scarcely one of them the beauty of which may not be seen and enjoyed by the spectator while he is walking past it, and without standing still at all. A herbaceous plant is chiefly interesting for its flowers, and the form of its foliage, in which in general there is little change of colour ; but, to these two sources of interest, trees and shrubs add the opening buds in spring, the colour of the unexpanded foliage immediately after it has burst from the bud, the fine green tinged with some other colour which the first leaves assume when they are fully expanded, and which continues more or less till the middle of June ; the intensely deep green of summer, which continues till the end of July ; the first changes of autumn to red or yellow, which commence in August ; and the dying off of all the different shades of red, crimson, yellow, orange, brown, and purple, which continues taking place till Christmas ; while some deciduous trees, such as the beech and hornbeam, the common oak in certain soils kept moist, and the *Quercus Taurin* in all soils and situations, retain their leaves, after they have become brown, till the following May. There are also, in deciduous trees, the colour and bloom of the young shoots of the current year ; the different colour which the bark of these shoots in many cases assumes the year following (*Salix decipiens*, for example) ; and the colour and texture of the older shoots, and of the branches and trunk. In addition to these sources of interest, there is a very great beauty in trees, which, from the improper planting of artificial plantations, is often overlooked, or rather concealed ; and that is, the ramification of the main surface roots at the point where they join the trunk. In general, trees are planted so deep that this ramification never appears above the surface, and the trunk of the tree seems fixed in the ground like a post which had been driven into it ; an appearance as contrary to truth and nature, and also to the health of the tree, as the shaft of a column without a base or a capital would, if employed in a building, be to architectural taste. To prevent this monstrous and unnatural appearance from occurring in the Derby Arboretum, I have directed all the trees to be planted on little hills, the width of the base being three times the height of the hill, so that the junction of the main roots with the base of the trunk will appear above ground.

Much more might be said to justify the preference which I have given to an arboretum over every other kind of arrangement for the Derby Garden, but I consider any farther remarks on the subject unnecessary.

A glance at the plan, *fig. 52.* in p. 522., will show that I have provided as great an extent of gravel walk as the space would admit of ; the total length, including the walk round the flower-garden, exceeding a mile. There is a straight broad walk in the centre, as a main feature from the principal entrance ; an intersecting broad and straight walk to form a centre to the garden, and to constitute a point of radiation to all the other walks ; and there is a winding walk surrounding the whole. As a straight walk without a terminating object is felt to be deficient in meaning, a statue on a pedestal is proposed for the radiating centre *i* in *fig. 52.* ; a pedestal, with a vase, urn, or other object, for the second circle in the straight walk *fig. 52. k* ; while the pavilions *fig. 54.* form terminating objects to the broad cross walk.

As a terminal object gives meaning to a straight walk leading to it, so it is only by creating artificial obstructions that meaning can be given to a winding walk over a flat surface. These obstructions may either be inequalities in the ground, or the occurrence of trees or shrubs in the line which the walk would otherwise have taken, so as to force it to bend out of that line. Both these resources have been employed in laying down the direction of the surrounding walk, though its deviation from a straight line has chiefly been made in conformity with the varying position of the trees in the belt already existing. This belt, and also the trees in the flower-garden, and in other parts of the plan, which were there previously to commencing operations, and which are

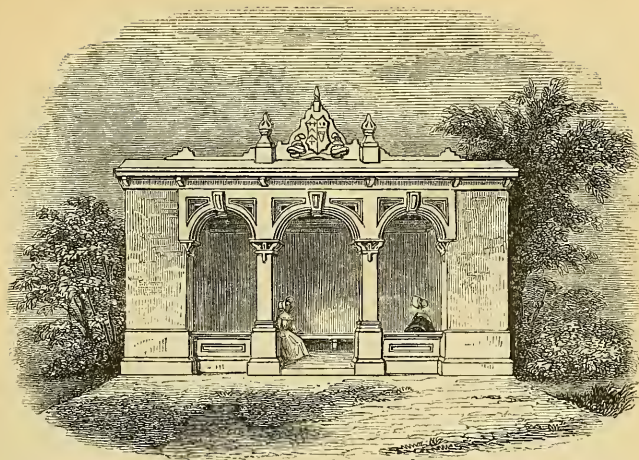

One of the Pavilions forming the Terminations to the cross Walk.
Style of James I.

left conformably to Mr. Strutt's instructions, are shown in the plan *fig. 55*. p. 536. The point of junction of one walk with another is always noticeable in an artistical point of view, and affords an excuse for putting down sculptural or other ornamental objects at these points; we have therefore placed Mr. Strutt's pedestals and vases in positions where, if they are kept properly supplied during summer with pots of flowers (the pot being placed in the inside of the vase so as not to be seen) they will form very ornamental objects; and the names of the flowers being written conspicuously on a card, and tied round the narrow part of each vase, and the kinds of flowers changed at least once a week, they will be instructive as well as ornamental. The kinds of plants should be such as have conspicuous red or orange flowers, in order to contrast harmoniously with the masses of green foliage and grass with which they are surrounded.

All the walks are drained by semicylindrical tiles laid on flat tiles in a line along the centre of the walk, and by cross drains from this line to the edges of the walk, communicating with gratings fixed in stone at regular distances. There is nearly a mile of drains, and there are 150 cast-iron gratings. The upper coating of gravel is of a good colour, brownish yellow; and, as when kept in proper order by rolling it binds very hard and smooth, the walks will be of the most dry, comfortable, durable, and agreeable description.

In order to disguise the boundaries of the ground, and to conceal the persons walking in the side walks from those in the centre walks, I have raised undulating mounds of soil, varying in height from 6 ft. to 10 ft., in the directions indicated by the lines in the plan *fig. 52.*, and by the shadows in *fig. 55.*; and these, even without the aid of the trees and shrubs which are planted on them, effectually answer the ends proposed.* Certain spaces on the lawn throughout the garden are left perfectly smooth and level, on which tents may be fixed, or parties may dance, &c. I should have made certain hollows and winding hollow valleys, as well as the hills and winding ridges; but the retentive nature of the soil, the difficulty, or rather the absolute want,

* A lithograph plan of the garden, on a larger scale, shows these mounds, and also the mode of planting the garden, much more correctly than the engraving *fig. 55*. It is sold by the curator, at the lodge, at 2s. 6d.; or, it sent post paid, 2s. 9d.

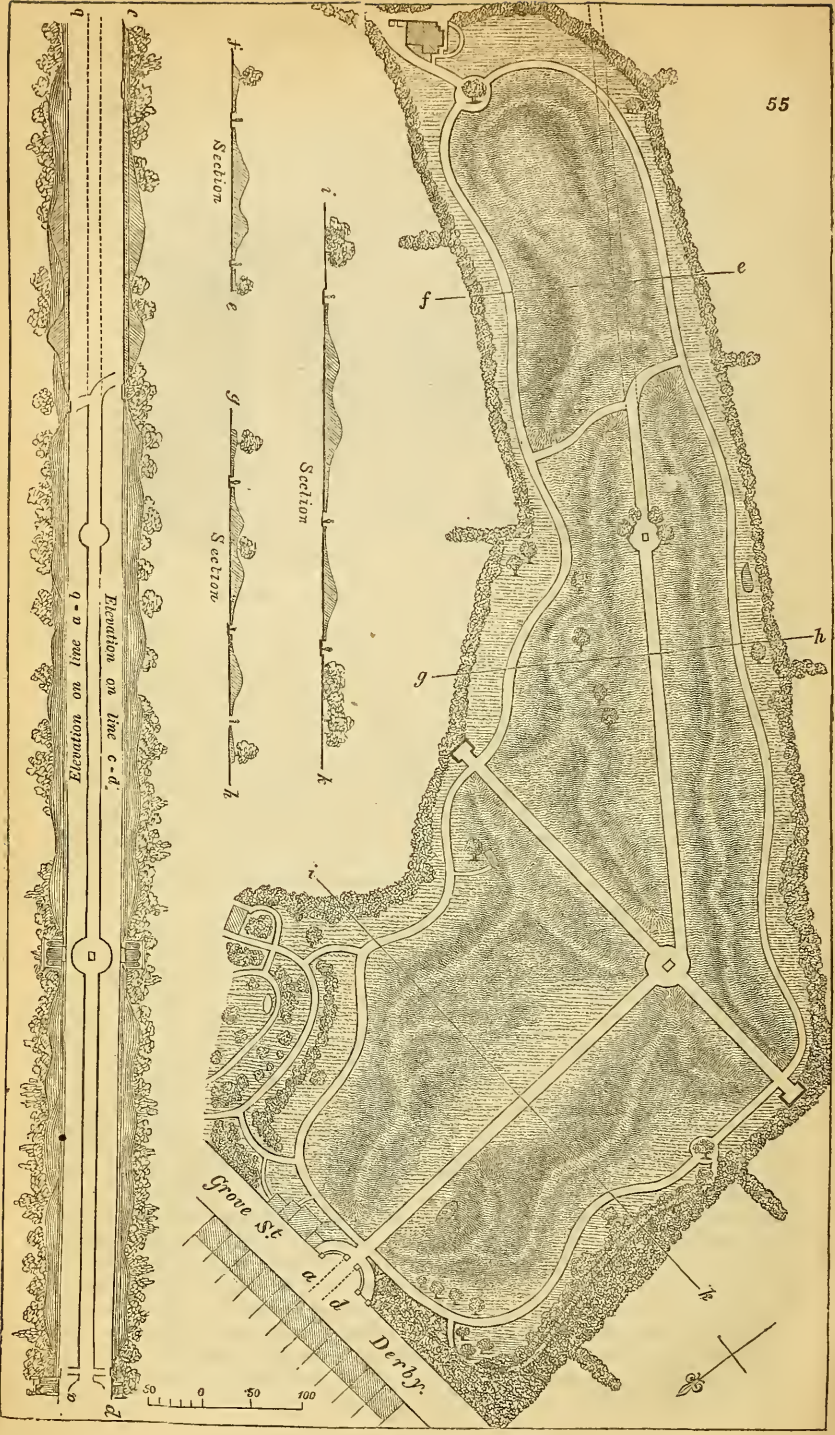

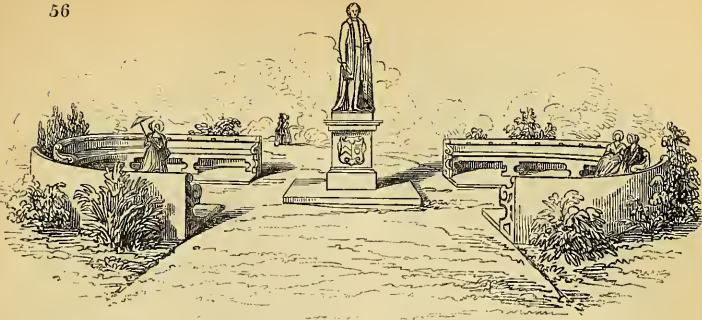

Design for a Statue and Stone Seats for the radiating Centre of the Derby Arboretum.

of drainage for such hollows, as well as the very limited space, and the necessity of having a broad, straight, nearly level walk down the centre, rendered this impracticable.

In moving the ground, care has been taken to preserve some of the old surface soil to form the new surface; and this new surface has also been drained where necessary, and every where rendered perfectly smooth and even, by raking and rolling, before sowing the grass seeds.

The seats have been designed and placed, chiefly by Mr. Strutt himself, reference being had to the following rules:—To make choice of situations under the shade of trees already existing in the belts, or of situations where some kind of view or feature is obtained; to place some in gravelled recesses along the sides of the walks, and others on the turf; some open to the sun for winter use; but the most part looking to the east, west, or north, for summer use. Those seats which are placed in recesses ought to be 1 ft. back from the edge of the walk, in order that the feet of persons sitting on them may not be in the way of passers by; and the gravelled recess should extend 6 in. beyond the seat behind and at each end, for the sake of distinctness, and to prevent any difficulty in weeding the gravel or mowing the grass. No seat should be put down, along the walks, in such a situation as to allow persons approaching it to see the back of the seat before they see the front of it; and, hence, the seats should generally be placed in the concavities of the turns of walks rather than in the convexities of bends. No seat to be put down where there is not either a considerable space directly in front, or at an angle of 45° , or some other equal and large angle on each side. No seat to be put down where there will be any temptation to the persons sitting on it to strain the eye looking to the extreme right or left. None to be put down where more than one point of the boundary of the garden can be seen from the seat. None to be put down on the tops of the mounds, by which a person sitting would, at least before the trees and shrubs grow up, get a panoramic view of the entire garden, and thus defeat the main object of the mounds, and of the winding direction of the side walks. No seat to be put down, nor any device contrived, by which both the lodges can be seen at once from the same point of view; or even where one of the lodges and one of the pavilions can be seen from the same seat. Seats which are placed on the lawn always to be backed by some of the trees or shrubs there, so that no person may ever come close up to a seat from behind; or, if seats are placed in the open lawn without trees or shrubs near them on either side, then such seats must be made double, with a common back in the centre, or they may be benches without backs, or single seats, such as chairs or stools. All fixed seats, whether on the lawn or on gravel, to have foot-boards for the sake of aged persons and invalids. Round the central circle the seats should have stone backs, and a more architectural character than in any other part of the garden, as shown in *fig. 56*.

57

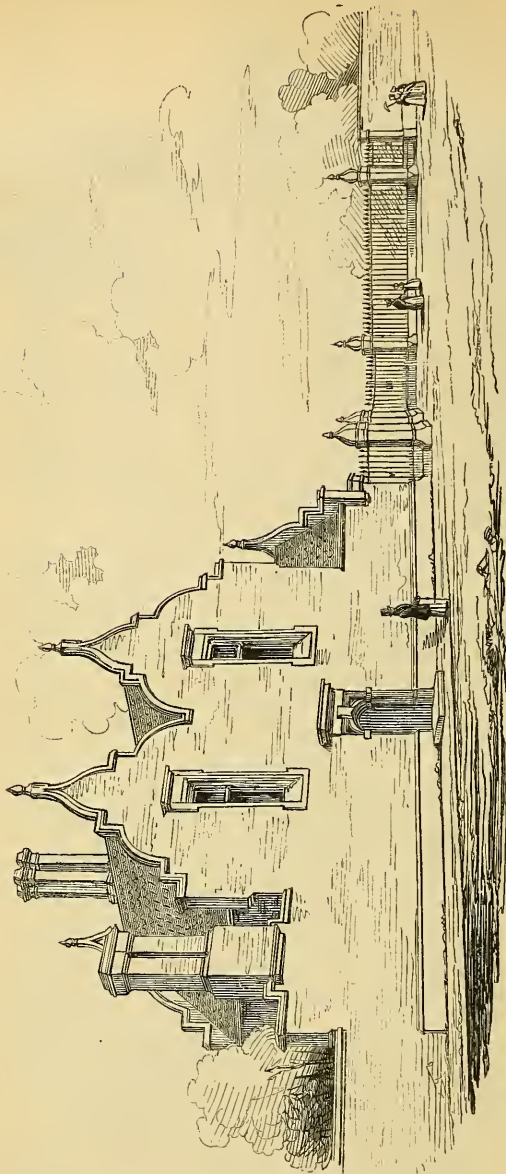

*Exterior View of the principal Entrance Lodge and Gates to the Derby Arboretum.
Style Elizabethan.*

The flower-garden with its covered seat, the cottage in it with its public tea-room, and the ivied tool-house formerly attached to Mr. Strutt's kitchen-garden, are preserved; and also a large weeping ash with seats beneath, the branches of which have been trained into a regular form by iron rings.

In order to design the entrance lodges and gates, and the central statue, I called in the aid of Mr. E. B. Lamb, M.I.B.A., whose designs for the lodges

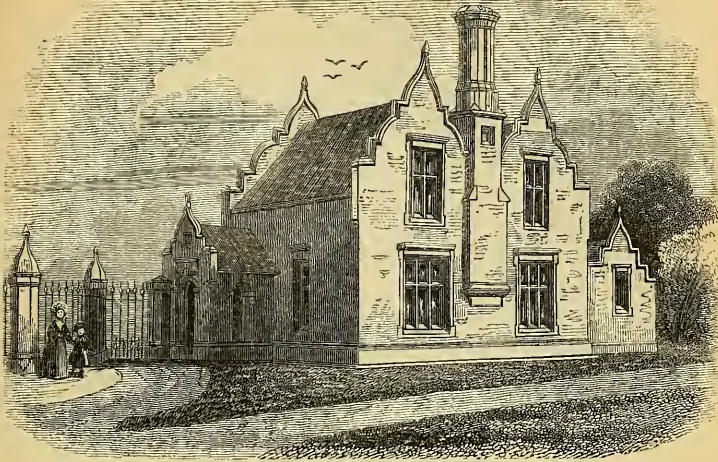

Interior View of the main Entrance to the Derby Arboretum.
Style Elizabethan.

and gates are shown in *figs.* 57. to 60., and the ground plans of which are in accordance with Mr. Strutt's instructions in regard to public rooms, yards, and other accommodations. Mr. Lamb also designed *fig.* 56. ; and it may be proper to state that the suggestion of the pedestal and statue is entirely my own, and formed no part of my instructions ; and that the idea may be either carried into execution or not, as the corporation, after they are in possession of the garden, may think fit. If a statue be not placed here, the design of the garden will not be complete without an obelisk, or some such object, in the centre of the circle.

As my instructions were to preserve as much as possible the belt and the trees in the interior of the ground already existing, I considered it most convenient to adopt the surrounding walk as a line of demarcation between the collection or arboretum in the interior of the grounds, and the miscellaneous assemblage in their circumference. Had the belt not existed, I should have extended the arboretum over the ground occupied by it, and thus have obtained room for a greater number of species, and a larger space for each individual tree and shrub. As things are, I have extended the belt in those places where it was wanting, and added to its interest by evergreen undergrowths, such as rhododendron, kalmia, laurustinus, box, holly, and mahonia ; by low trees, such as arbor vitæ, red cedar, and cypress ; and by large trees, such as cedar of Lebanon, silver fir, hemlock spruce, and evergreen oak. I have also introduced a collection of 100 different kinds of roses, all named ; and placed the genera *Ulmus*, *Quercus*, *Pópulus*, and *Sàlix* in the new part of the belt, in order to give more room in the interior.

All the ground not covered by trees or shrubs I have directed to be laid down in grass to be kept closely mown ; but round each tree and shrub forming the collection I have preserved a circular space, varying from 3 ft. to 5 ft. in diameter, which (with the hill in the centre, comprising one third of the width of the circle, and on which the plant is placed) is not sown with grass, but is always to be kept clear of weeds. The use of this circle and little hill is to prevent the grass from injuring the roots of the trees while young, and to admit of the larger roots showing themselves above the surface, where they ramify from the stem, as before mentioned. Some few of the shrubs which require peat soil, such as the heaths, have had that soil prepared for them ; and the genera *Cistus* and

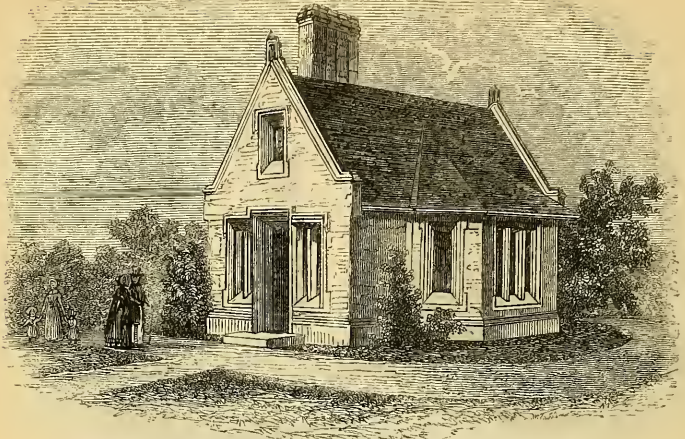

*East Lodge of the Derby Arboretum, showing the public Room.
Tudor Style, time of Henry VII.*

Helianthemum, which are apt to damp off on a wet surface, are planted on a raised mass of dry rubbish, covered with stones, as shown at 40. in the plan *fig. 52. p. 522.* All the climbing plants throughout the collection have iron rods, with expanded umbrella-like tops, placed beside them; the lower end of the iron rod being leaded into a block of stone, and the stone set in mortar on brickwork, so that the upper surface of the stone appears 1 in. higher than the surrounding surface. This appearance of the stone above the surface is not only more architectural and artistical, but better adapted for the preservation of the iron at the point of its junction with the stone, than if the stone were buried in the soil.

With respect to the annual expense of keeping up the garden, it will be evident to those who have seen it, or who understand this description, that it will chiefly consist in mowing the grass in the summer season. As the extent of grassy surface to be mown will be reduced by the space occupied by the walks, and by the circles of earth on which there is no grass (on which the trees and shrubs stand, or which those in the belt cover entirely), to about six acres, one man will be sufficient to mow and sweep up this extent of lawn during the whole summer; the daily space to mow being about half an acre, and the grass mown to be distributed over the naked circles on which the trees and shrubs stand. All the other work which will require to be done in the garden during summer, such as weeding the walks, rolling them, weeding the circles on which the trees and shrubs stand, picking off insects from the plants, watering the ground with lime water where worm-casts appear, wiping the seats every morning so as to remove the excrement of birds, or whatever leaves or other matters may drop from the branches of the trees over them, &c. &c., may be accomplished by a second labourer. The head gardener or curator may manage the flower-garden and the vases of flowers at the junctions of the walks, and see that the company who walk in the garden do not injure the plants, &c.

During the winter season, or from December 1. to May 1., more than one labourer in addition to the head gardener will be unnecessary. The second labourer may at that season, therefore, be allowed to retain his house, and seek for labour elsewhere; and the saving thus made, it is presumed, would be a contribution towards the purchase, from some of the Derby nurserymen or florists, of all the flowers or other plants that may become necessary to fill the vases from May till October. Unless some arrangement of this sort be made,

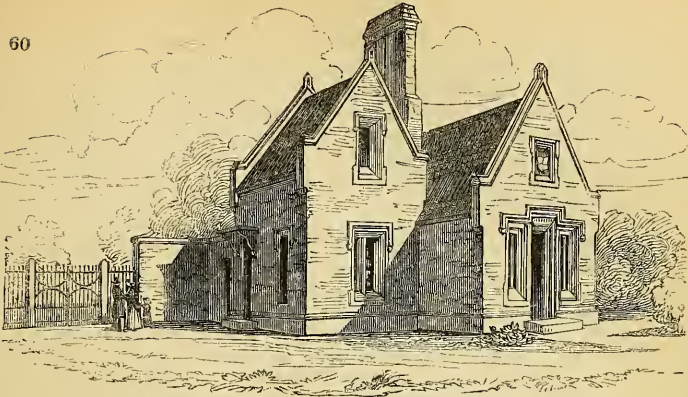

*East Lodge of the Derby Arboretum, showing the Entrance Gates.
Tudor Style, time of Henry VII.*

it will be impossible to do justice to the plan of exhibiting plants in the vases ; because the flower-garden, if made a source of supply, would be injured in appearance ; and to have a reserve garden, with a green-house or pit, would involve much more expense than hiring the plants from a nurseryman, and would be far from attaining the object in view so effectually. On the supposition that there were fifty vases, there would then be fifty different kinds of named flowers or green-house plants in them every day during the summer ; and supposing that these kinds were changed once a week, and the same kind not repeated more than once in the same season, there would then have been upwards of 500 different kinds of handsome plants, with their names attached, exhibited to the public in the course of a single year. To give an idea of what these plants might be, I shall suppose them to consist of 200 showy hardy and tender annuals, 100 dwarf dahlias, 100 choice herbaceous plants, 100 geraniums, 100 Australian plants, 50 heaths, and 50 miscellaneous green-house plants, including fuchsias, cacti, aloes, &c. Plants to this extent, in the neighbourhood of London, would be lent for a week each at an average of 1s. a pot, so that, for the season, the total expense might be 50*l*. Even half this sum would be productive of considerable effect and instruction.

The plan of the Arboretum was made in May, 1839 ; and, being approved of by Mr. Strutt, as soon as the crop of hay was removed from the ground, in the July following, the work was commenced by Mr. Tomlinson, a contractor for ground work, who laid out the walks, made the drains, and raised the general masses of the mounds. The mounds were afterwards moulded into suitable shapes, and connected by concave sides and lateral ridges with the surrounding surface, under the direction of my assistant, Mr. Rauch, who also superintended the planting of all the trees and shrubs, and all the other details connected with the ground, till the completion of the whole in September, 1840. The trees and shrubs were supplied chiefly by Messrs. Whitley and Osborn, but partly also by Mr. Masters of Canterbury ; and the miscellaneous collection of roses was furnished by Mr. Rivers of Sawbridgeworth ; the mistletoe was supplied by Mr. Godsall of Hereford ; and some species, which could not be procured in the nurseries, were obtained from the Horticultural Society's Garden. The lodges and pavilions were designed by Mr. Lamb, as already mentioned : the north, or main, lodge in the Elizabethan style ; the east lodge in the Tudor style, and in that variety of this style which was prevalent in the time of Henry VII. ; and the pavilions in the style of James I. They were all built by Mr. Thompson of Derby ; and the gates to the north, or principal, lodge were cast from Mr. Lamb's designs by Messrs. Marshall, Barber, and Co., of Derby.

MANAGEMENT OF THE DERBY ARBORETUM.

Supposing that the curator will occupy the north lodge, and that two labourers will occupy the other two cottages, I feel confident that these three persons will find no difficulty in keeping the entire garden in the very highest order at every period of the year. What I consider to be the highest order consists in the following particulars :— The walks should be at all times perfectly dry, smooth, firm, free from weeds, worm-casts, or other extraneous matters, and with the gravel of a good colour : the turf equal in thickness, free from all broad-leaved plants except clover, closely mown, smooth, firm, dry, and everywhere without worm-casts, mole-hills, ant-hills, dead leaves of trees, bits of paper, or any other extraneous matter which may be blown about, or left on it by visitors : the flower-garden perfectly free from weeds, and every bed filled with plants in a healthy state, and the beds well covered with flowers : the vases filled with flowers, in the manner above described, from the middle of May till October ; the flowers being in pots, and either of green-house or hardy kinds, named on a card tied to the narrow part of the vase, and changed not seldomer than once a week ; the same species not being more than twice introduced during the same season. All the trees and shrubs to be kept without dead wood, perfectly free from caterpillars, aphides, curled leaves, honey-dew, leaves which have been killed, or branches which have been broken accidentally, and from flowers or fruits which have decayed and not dropped. The climbers or twiners to be kept tied up ; the spaces round the trees free from weeds ; the seats quite clean ; the name tallies in complete repair ; the boundary fence, lodges, and gates, in complete repair ; and the labourers, and their wives and families who attend on persons who enter the garden or the lodges, clean and neatly dressed. This may be considered as the criterion of good regular management ; but there are certain points to which I wish to direct the special attention of the curator and of the public, and especially of the public press.

The first point respects pruning. On no account whatever is the knife to be applied to any of the trees or shrubs, except in the following cases :— for the purpose of cutting out dead wood, branches broken by the wind or by any accident, dead or decayed flowers or fruit, or for removing the suckers or side shoots which come out below the grafts of such species or varieties as have been budded or grafted. No decaying leaves whatever, and no ripe fruit, are on any account to be cut off ; but leaves which wither or are killed in the course of the summer may be removed as soon as they are perceived. Pruning is prohibited, in order that every plant may show its natural shape and habit of growth ; whether by growing erect, spreading horizontally, or throwing suckers up, or rambling shoots out, on every side. The suckers are not even to be thinned out, but every plant is to be allowed as perfect a freedom of growth as if it were in its native habitat. The only exception is, such climbing, twining, or trailing plants as are to be trained up to the rods or props prepared for them, instead of allowing them to trail on the ground ; but this is to be done without cutting off or shortening any of their shoots.

The reason for not removing decaying leaves is, that a great part of the beauty of all trees and shrubs consists in the change of colour which takes place in the leaves in the course of the autumn, and more especially a short time before they drop off. Hence I repeat, that the leaves on all the plants (unless accidentally killed) are to be allowed to decay naturally on the shoots, and not to be touched till they have fallen on the ground, when they are to be swept up and laid on the circular space of earth which is to be preserved round each plant. The use of laying the leaves on the space around each plant is to serve as a mulching or non-conducting cover to retain moisture, and also because the best manure for every description of plant is decayed foliage. When at any time the leaves laid at the roots of the plants are blown off by the wind, they must be swept on again ; and this practice must be continued till the leaves have so far rotted as to adhere to the surface of the soil. In

some cases, where the roots are not prominent, the ground may be slightly stirred with the points of the prongs of a fork so as to cause the leaves to adhere, but this must not be done generally. By means of these leaves, and the short grass cut off by the scythe, a sufficient mulching will be produced for each plant, to keep in the moisture during summer, to keep out the frost to a certain extent during winter, and, as the mulching decays into mould, to supply nutriment to the roots.

In consequence of this mode of management, and the limited space which there necessarily is between the plants, some species will soon grow so large as to intermingle their branches, or their suckers, with those which are adjoining them. Whenever this is the case, the overgrown plants must not be thinned or pruned, but be entirely taken up by the roots, the soil stirred up to the depth of 2 or 3 feet, some fresh soil added, and a young plant procured from the nursery of the same kind as that taken up, and planted in its place, on the summit of a circular hill of earth of the same diameter and height as at first: that is, as before stated, on a hillock of from 3 ft. to 5 ft. in diameter, and from 1 ft. to 1½ ft. high in the centre, above the adjoining surface. The brick tally is then to be replaced on a foundation of bricks, so as not to be buried above 1 in. by the soil, as at first planting the Arboretum. Some of the poplars and elms may require to be taken up and renewed in this manner in the course of 15 or 20 years; and perhaps some of the shrubs which throw up numerous suckers, such as the common lilac and common philadelphus, and some which throw out rambling shoots, as the common bramble, may require the same treatment at the end of the same period, or before.

Whenever any of the branches or suckers extend so far as to cover or partially obscure the brick tally, it and its foundation of bricks must be taken up and removed 1 or 2 feet further from the plant; and whenever the glass of any tally is broken, or the card with the name becomes dim, or any other accident happens to it, it must be repaired or renewed by the curator from the reserve stock of bricks, printed cards, and pieces of glass, kept in the north lodge and the flower-garden cottage.

The miscellaneous collection of roses in the surrounding belt will require particular attention to prevent them from being injured by the adjoining evergreens; and, as roses are short-lived plants, some few of them may, perhaps, die every year. Whenever this is the case, the root of the dead plant must be taken up, the soil thoroughly stirred, some fresh soil and manure added, and a new plant, of the same kind as before, inserted. When a new plant of the same kind cannot be procured, some other kind of rose of the same section, and not already in the collection, must be planted, and a new name tally prepared accordingly.

As the trees and shrubs in the belt are much thicker than those in the collection, they will have to be thinned out from time to time; in doing which, the weakest and least valuable plants must be removed first, so that the belt may never have a crowded appearance, or choke up the roses, and at the same time be sufficiently filled with evergreens to conceal, in a great measure, the boundary hedge from the walk. Many of the trees in this belt, and also a number of the old trees of common sorts left standing in the flower-garden and in the collection, will have to be removed in the course of a few years, otherwise the effect of the whole, as well as the growth of all the more delicate kinds now planted, will be materially injured. In a word, it forms no part of the design of this Arboretum to exhibit large trees, more especially of the common kinds; and whenever any one of these, or, indeed, any tree whatever in the Arboretum, reaches a greater height than 40 or 50 feet, it should be removed. That height is quite sufficient for producing shade, and for showing the form and character of the tree, and its flowers and fruit; and nothing more is required, or can be admitted in an arboretum on so limited a piece of ground. If this part of the management laid down be neglected, the rapid-growing large trees will soon overtop the slow-growing smaller ones and the shrubs, and ultimately destroy all the finer kinds.

As several of the trees and shrubs forming the collection are small plants of kinds recently raised from seed in the Horticultural Society's Garden, and just introduced into the country, it is not improbable that they may, in some cases, be wrongly named; but, if I am permitted, I shall be happy to examine, free of expense, all the plants, at intervals of two or three years, and correct the nomenclature, when necessary, during my life; because much of the usefulness of this Arboretum will depend on the nomenclature being correct.

As new species of trees and shrubs from foreign countries are continually increasing the collections in British gardens, when any of these are to be added to the Derby Arboretum, it can only be done with propriety and success by taking up the whole and replanting, adjusting the distances to the estimated heights to which the plants will grow in the given climate and soil. It will be better, therefore, to make no additions whatever for the next 15 or 20 years, and then to take the whole up and replant, introducing the new kinds in their proper places.

The most effective mode of increasing the number of species would be, — 20, 30, or 40 years hence, to take up the trees and shrubs of the belt, as well as all the other trees and shrubs; to reduce the whole to a *tabula rasa*; to surround the whole with a boundary wall; to form a narrow border and a walk within this wall; to plant the wall with select kinds which would not grow so well in the open ground; and to include the remaining part of the ground occupied by the belt in the present Arboretum. There would then not be a single duplicate tree or shrub within the enclosure, except some of those in the miscellaneous collection against the wall, and those contained in the flower-garden. This rearrangement of the whole would create a new interest, not only by the change in general appearance, but by the many new kinds which would be added, and by the great beauty and interest of the miscellaneous collection against the wall, and of the bulbous-rooted herbaceous plants which might be planted at its base. In this way the Arboretum might be rearranged every 20, 30, or 40 years, for an indefinite period; always maintaining its original character of entertainment and instruction, and always kept up to the existing state of knowledge and arboricultural riches.

As improvements are continually making in the nomenclature of plants, the names should be revised by a competent botanist every time the Arboretum is taken up and replanted.

To prevent the plants from being injured by giving away cuttings for propagation to nurserymen, or specimens to botanists, the curator ought to be forbidden to give away any, except to one substantial and extensive local nurseryman, and this only upon condition that such nurseryman agreed to supply from his own nursery, or to procure from other nurseries, all plants that might be wanted as substitutes for overgrown plants removed, or for deaths. At the same time, every nurseryman and botanist, as well as all other persons, ought to be allowed to inspect and study the plants at all seasons, and for this purpose the curator should keep in his lodge the copy of my *Arboretum Britannicum*, which I have presented to the Arboretum, and should allow all enquiring persons to consult it. For general observers and lovers of trees and shrubs, the catalogue contained in the pamphlet prepared by me, and sold by the curator, or my abridged edition of the *Arboretum*, will be sufficient, at least for some years to come. To check idle curiosity and a needless waste of time, the curator might be allowed to charge 1*d.* or 2*d.* per hour for the use of the copy of the *Arboretum* in the lodge; but, on no consideration whatever, ought he to be allowed to take it, or allow it to be taken, out of the public room.

It is to be observed, that keeping the vases supplied with flowers during the summer season forms no essential part of the Arboretum, though it will add much to the popular interest of the garden. If, therefore, it should be determined to add to the number of pedestals and vases, this can only be done with propriety, to such an extent as will place one at each angle formed by the junction of the walks, and one at each end of every fixed seat placed along the

edges of the walks. To place any vases on the turf, either beside the seats there, or by themselves, would be altogether inartistical, and greatly interfere with the effect of the trees and shrubs. It is earnestly entreated, therefore, that nothing of this kind may be done. If any one should be desirous of presenting statues to the Arboretum, the only situations in which they can be placed are those pointed out for the vases, and for which they may be substituted, with the exception only of the centres of the two circles, in one of which, viz. that which forms the radiating centre of the walks, a statue of the liberal and benevolent founder ought to be placed, as shown in *fig. 56.* in p. 537. ; in the other there is a figure of the Florentine boar.

In the public room in the curator's lodge a blank book should be kept, in which strangers who visit the Arboretum should be invited to write their names, with any remarks which may occur to them, especially with reference to the order in which the Arboretum is kept, and the degree in which these instructions for management, or any others that may be given by Mr. Strutt or the committee of management appointed by the corporation, may appear to have been attended to. I also earnestly request the public press of Derby to examine the garden from time to time, and to report on its condition, and on the manner in which these instructions have been complied with by the corporation of Derby and the curator of the garden.

The Derby Arboretum was assigned over to trustees by Mr. Strutt, on the 16th of September, 1840; and Mr. Strutt's Address to the Town Council of Derby, and the ceremonies which passed on that occasion, and on the succeeding days, will be found in the Derby newspapers of that week, and in the *Gardener's Magazine* for November.

ART. II. *Botanical, Floricultural, and Arboricultural Notices of the Kinds of Plants newly introduced into British Gardens and Plantations, or which have been originated in them; together with additional Information respecting Plants (whether old or new) already in Cultivation: the whole intended to serve as a perpetual Supplement to the "Encyclopædia of Plants," the "Hortus Britannicus," the "Hortus Lignosus," and the "Arboretum et Fruticetum Britannicum."*

Curtis's Botanical Magazine; in monthly numbers, each containing seven plates; 3s. 6d. coloured, 3s. plain. Edited by Sir William Jackson Hooker, LL.D., &c., Professor of Botany in the University of Glasgow

Edwards's Botanical Register; in monthly numbers, new series, each containing six plates; 3s. 6d. coloured, 3s. plain. Edited by Dr. Lindley, Professor of Botany in the University College, London.

Paxton's Magazine of Botany, and Register of Flowering Plants; in monthly numbers; large 8vo; 2s. 6d. each.

The Botanist; in monthly numbers, each containing four plates, with two pages of letterpress; 8vo; large paper, 2s. 6d.; small paper, 1s. 6d. Conducted by B. Maund, Esq., F.L.S., assisted by the Rev. J. S. Henslow, M.A., F.L.S., &c., Professor of Botany in the University of Cambridge.

Maund's Botanic Garden, or Magazine of Hardy Flower Plants cultivated in Great Britain; in monthly numbers, each containing

four coloured figures in one page; large paper, 1s. 6d.; small, 1s.
 Edited by B. Maund, Esq., F.L.S.

RANUNCULA' CEE.

1605. AQUILE'GIA [1840. 46.
 glauca Lindl. glaucous $\frac{1}{2}$ Δ or 2 my.jn. Pa.Y Himalayas 1839. D co. Bot. reg.

A very beautiful plant, both from its large and handsome pale yellow or cream-coloured flowers, and from its glaucous foliage. Though raised from East Indian seeds, it is not included in the lists of columbines given by Drs. Wallich and Royle, and it may therefore, Dr. Lindley conjectures, "be considered by those excellent botanists as a variety of their *A. pubiflora*," but it is distinct from that species "in the larger and sweet-scented straw-coloured flowers, the nearly smooth stems, the very glaucous leaves, and the shaggy ovaries." (*Bot. Reg.*, August.)

fragrans Benth. fragrant $\frac{1}{2}$ Δ or $\frac{1}{2}$ my Pa.Y Himalayas 1839. D co. Botanist, 181.

Very nearly allied to the last species, but differing in having the spines of the petals hooked inwards, and the leaves not being glaucous. The flowers, also, are still larger and handsomer. (*Botanist*, Aug.; and *B. M. R.*, No. 140., Sept.)

brachyceras F. et M. short-spurred $\frac{1}{2}$ Δ or $\frac{2}{3}$ my B N. Europe 1838. D co. Bot. gard. [755.

A dwarf species with blue flowers, the petals being slightly tipped with green. It was named by Messrs. Fischer and Meyer, in their seed catalogue of the St. Petersburg Botanic Garden; and it was raised in the Birmingham Botanic Garden, from Russian seeds, in 1838. (*Bot. Gard.*, Sept.)

A. pubiflora Wall. A hardy East Indian perennial, which grows about a foot high, and has "pale purple scentless flowers." According to Dr. Royle, it is abundant among the Himalayan Mountains, at elevations of from 6000 to 10,000 ft. (*B. M. R.*, No. 141., Sept.)

1599. DELPHINIUM 14133 chinense fl. pl. Paxt. Mag. of Bot.

A handsome double-flowered variety of the Chinese larkspur, which is easily multiplied by cuttings. (*Mag. of Bot.*, Sept.)

Aconitum ovatum Lindl. "A hardy aconite, with undivided leaves, which are merely crenated, and embrace the stems." It is a native of Cashmere; and the flowers, which are of a dull purplish green, are in loose pyramidal racemes. (*B. M. R.*, No. 118., July.)

Capparidaceæ.

Cleome lutea Hook. A native of North-west America, growing about 2 ft. high, and with yellow flowers. It is either an annual or biennial. (*B. M. R.*, No. 117., July.)

Malvaceæ.

Abutilon vitifolia Lindl.; *Sida vitifolia* Cav. A handsome evergreen low tree, a native of Chili, where it grows about 6 ft. high; the flowers, which are white, and "grow in umbels, are fully 3 in. in diameter," and the leaves are as large as those of the vine. It was raised from seed, about four years ago, in the Trinity College Botanic Garden, Dublin; and plants have stood there, for the last three years, without any protection. (*B. M. R.*, No. 114., July.)

Hibiscus (§ *Azanza*) *Wrayæ* Lindl. A handsome green-house shrub, with fine large lilac flowers, 5 in. across, and very showy. Raised from Swan River seeds, by Mrs. Wray of Cheltenham, in honour of whom it is named. (*B. M. R.*, No. 149., Sept.)

Rutaceæ.

399. ZIERIA 3342 lævigata Botanist, 185.

Leguminosæ.

1985. LUPINUS
 leptocarpus Benth. slender-fruited \odot or 3 su P Mexico 1839. S co. Bot. reg. 1840, 33.

"A hardy straggling biennial," 2 or 3 feet high, which flowers late in the summer, and greatly resembles *L. rivularis*. The seeds were "collected by

M. Hartweg in pine woods, near Bolanos, at the elevation of 8000 ft. above the sea." (*Bot. Reg.*, July.)

2837. *ACA`CIA*
dentifera *Benth.* tooth-bearing 𐄂 𐄂 or ap Y Swan River 1839. C s.l.p. Botanist, 179.

This species is a native of the colony of the Swan River, where it was found by Mr. James Drummond. "It is nearly allied to the *A. saligna* of Labillardière, but the leaves are much narrower, and the form of the calyx is very peculiar." The specific name of "tooth-bearing" alludes "to the tooth-like remains of the stipules." (*Botanist*, Aug.)

2623. *PHYSOLO`BIUM*
carinatum *Benth.* keeled 𐄂 𐄂 4 my R King George's Sound 1839. C s.l.p. Botanist, 183.

This pretty Australian plant has rich crimson flowers, and a slender climbing stem, which however does not extend very far. The pod is the most remarkable feature, as it is "from half an inch to three quarters long, much swollen, and very hairy." It is one of a new genus founded by Mr. Bentham, and of which three or four species are already known. It flowers and seeds freely. The following appear to be the principal points in which it differs from its allied genera. "The colour and form of the flower are those of a *Zichya*, but the peduncles are few-flowered and loosely dichotomous, not umbellate, and the pod is inflated as in *Crotalaria* or *Baptisia*. The inflorescence is that of a true *Kennedya*, but the form of the flower, as well as the pod, are very different." (*Botanist*, Sept.)

2066. *TRIFO`LIUM* 18530 involucreatum.

This plant, or a variety of it, has been raised from Mexican seeds sent home by M. Hartweg, and found to produce numerous heads of lemon-coloured flowers, instead of pale purple, as stated in *Hort. Brit.*, p. 299. (*B. M. R.*, No. 116., July.)

+ *Hardenbergia digitata* Lindl. is "a handsome green-house twiner, raised from Swan River seeds by Mr. Toward, under whose skilful management so many new species have been introduced." (*B. M. R.*, No. 142., Sept.)

Rosaceæ.

Spiræa rotundifolia Lindl. A species the seeds of which were received from Cashmere, and which, though it has not flowered, appears to Dr. Lindley evidently to belong "to the same division as *S. vacciniifolia*." (*B. M. R.*, No. 159., Sept.)

Schizonotus tomentosus Lindl.; *Spiræa Lindleyana* Wall. This new genus has been formed by Dr. Lindley on this species and *S. sorbifolia*. The generic name, which signifies split-back, alludes to "the remarkable cohesion of the carpels into a 5-celled capsule, whose cells split open at the back for the escape of the seeds;" and it is on this character that the genus is founded. (*B. M. R.*, No. 156., Sept.)

Onagræcæ.

- LOPE`ZIA
lineata *Zucc.* linear 𐄂 𐄂 pr 3 ja.f R Mexico 1839. S co. Bot. reg. 1840, 40.

A soft-wooded green-house shrub," flowering in winter, but principally in the latter end of January and the beginning of February (see p. 293.). The flowers are very abundant, but they do not differ materially from the common annual kinds. (*Bot. Reg.*, July.)

Passifloræcæ.

1923. *PASSIFLO`RA*
verrucifera *Lindl.* wart-bearing 𐄂 𐄂 cu 30 ap Pa.G ? Brazil 1837. C pl Bot. reg. [1840, 59.

A curious plant, from the bright green warts produced on the margin of its sepals and bractea. It is a green-house climber of easy culture, nearly allied to *P. incarnata* and *P. edulis*; and it "will grow with great luxuriance if planted in the border of the conservatory. The soil which suits it best is rich loam, mixed with peat and sand. It can be multiplied freely by cuttings." (*Bot. Reg.*, Sept.; and *Misc.*, No. 105., July.)

Crassulàcæ.

Sedum multicaule Wall. A pretty rockwork plant, with fleshy leaves and yellow flowers, from the East Indies. (*B. M. R.*, No. 124., Aug.)

Cactàcæ.

1472. CÈREUS

lâtifrons Pfeiff. broad-stemmed ✱ □ or 10 au W S. America 1830. C s.l Bot. mag. [3813.
Synonymes: *Cereus oxypetalus* Dec., *Epiphyllum lâtifrons* Zucc.

“A tall-growing plant, incapable of supporting itself.” It is jointed and much branched, the branches being very broad and leaf-like. The flowers are white, tinged with pink, with a spreading limb, and a very long and slender tube. It flowered in the collection of Messrs. Mackie of Norwich. (*Bot. Mag.*, August.)

*Rubiàcæ.*378. BOUVA'RDIA splendens *Graham*. (See p. 146.)

Synonyme: *B. triphylla* var. *splendens* Lindl.

Dr. Lindley considers this plant to be only a variety of *B. triphylla*; as, though it differs “in its more scarlet, brighter, and larger flowers, its more pubescent surface, its more vigorous habit, and in the deep purple stain on all its branches,” he does not think that there is any “solid mark of distinction.” (*Bot. Reg.*, July.)

Oxyanthus versicolor Lindl. A beautiful stove shrub, from Cuba, with fragrant flowers, which are first white, then pink, and lastly crimson. (*B. M. R.*, No. 150., Sept.)

Conpòsitæ.

Brachycome iberidifolia Benth. “A beautiful little hardy annual,” from the Swan River, “with finely cut leaves like the *Nigella*, and flowers of the deepest blue. There is also a white variety, but it is not yet introduced. (*B. M. R.*, No. 148., Sept.)

+ *Triptilion spinosum* Ruiz et Pav. A very beautiful Chilian perennial, with bright blue flowers. (*B. M. R.*, No. 129., August.)

Goodenòviæ.

Eithales macrophylla Lindl. A strong-growing herbaceous plant, with large leaves, “and large, showy, yellow and brown flowers.” Raised from seeds purchased of Mr. James Drummond, collected near the Swan River. (*B. M. R.*, No. 119., July.)

Gesneriàcæ.

1698. GESNERIA

mollis H. et K. soft 3/4 Δ or 1 1/2 ap S Caraccas 1839. S p.l Bot. mag. 3815.

This plant flowered, for the first time in England, at Kingsbury, and the following is extracted from Mr. Beaton's account of it. “This species does not produce tuberous roots like the rest of the genus, yet the stems are herbaceous, and die down after producing seeds; at least I think so, from a cluster of scaly creeping stems now forming, of the colour of the plant, and which are analogous to the roots of *Trevirana coccinea*. The plant having begun thus early to provide itself with these creeping stems, for producing a succession of flowering stems, and for extending itself on all sides, may be taken in evidence that this species does not require much rest, like the large tuberous-rooted *Gesneriæ*. The seeds, like all of the genus, are very small, and should be sown in sand previously watered, and then pressed down gently in the wet sand, but not covered. The young plants will rise in a few days, and ought to be kept in a shady place till they are fit to be transplanted.” (*Bot. Mag.*, August.)

*Ericàcæ.*1339. RHODODE'NDRON 11021 caucasicum var. 5 hybridum *Hook*. Bot. mag. 3811.

A hybrid between *R. caucasicum* and *R. ponticum albiflorum*, raised by Mr. Veitch of Exeter in 1838. The flowers are white. (*Bot. Mag.*, July.)

1173. ERICA

Macnabiana Paxt. Mr. M'Nab's 2 □ or 1 au Pk hybrid 1837. C s.l.p. Paxt. mag. of [Bot. vii. p. 125.]

A hybrid raised by Mr. M'Nab from *E. aristata*, fecundated by the pollen of

E. inflata fimbriata. It is hard-wooded, and flowers nearly all the year, but principally in August. (*Pact. Mag. of Bot.*, July.)

Asclepiadaceæ.

CYRTOCERAS *Bennett* (*kurtos*, curved, and *keras*, a horn; in allusion to the curved state of the horn of the segments of the crown) *reflexum* *Benn.*

Synonyme: *Hoya coriacea* *Lindl.* (See Vol. XV. p. 244.)

This plant was "made the basis of a new genus by Mr. Bennett," not only on account of some points of difference from *Hoya* in the construction of the flower, but also because it does not send out roots from the stem, and its flower does not secrete a saccharine juice, (*Botanist*, July.)

Gentianeæ.

+ *Ophelia purpurascens* *D. Don*. A pretty little East Indian annual, "with narrow pale green leaves, and starry pink flowers, with green glands at the base of the petals." (*B. M. R.*, No. 158, September.)

Bignoniaceæ.

1706. BIGNO'NIA [reg. 1840, 45.
Tweediàna *Lindl.* *Mr. Tweedie's*  or 20 jn Y Buenos Ayres 1838. C l.p.s. Bot.

A beautiful plant of very easy culture, as it strikes readily from layers or cuttings, and grows freely from seeds, when they can be procured. It will grow well in any garden soil, but prefers a mixture of loam, peat, and sand, and it appears very nearly hardy. The flowers are of a bright golden yellow, and the species is nearly allied to *B. æquinoctialis*. (*Bot. Reg.*, August.)

Convolvulaceæ.

491. IPOMOE'A *Learii* *Pact.* (See p. 147.)

Synonyme: *Pharbitis Learii* *Benth.* *Botanist*, 184.

This beautiful plant Mr. Bentham considers to belong to the genus *Pharbitis* (see *Hort. Brit.*, p. 655), as it has more than four seeds to the capsule. (*Botanist*, September.)

By some mistake the flowers of this species are marked in p. 147. as dark red, instead of dark blue.

Boragineæ.

435. CYNOGLO'SSUM [1840, 50.
longiflorum *Royle* long-flowered $\frac{3}{4}$ Δ pr $1\frac{1}{2}$ su P.R Cashmere 1839. D co. Bot. reg.

A pretty hardy perennial, which flowers and seeds freely, in any common garden soil, from May to August. The flowers are larger and handsomer than those of most of the other species. The plant was raised from East Indian seeds imported by Dr. Royle, in May 1839. (*Bot. Reg.*, September.)

Labiataæ.

Salvia hians *Benth.* An East Indian perennial, with blue and white flowers, and wrinkled sagittate leaves. It somewhat resembles *S. bicolor*, but is far more handsome. (*B. M. R.*, No. 115., July.)

Acanthaceæ.

1727. RUE'LLIA 30610 *élegans* *Hook.*

Synonymes: *R. australis* *Cav.*, *R. achyranthifolia* *Desf.*, *R. parviflora* *Hort. Par.*

The name of *Ruellia australis* is restored to this species, having been first given to it by Cavanilles. (*Botanist*, July.)

Primulaceæ.

Anagallis alternifolia *Cav.* A pretty little plant with trailing shoots, "and delicate yellowish flowers tinged with pink. It was raised at Carclew, from earth sent from Rio Janeiro." (*B. M. R.*, No. 144., Sept.)

Amentaceæ.—Seven species of Mexican oaks figured in Humboldt and Bonpland's work, *Plantæ æquinoctiales*, vol. ii., and in our *Arb. Brit.*, vol. iv., and two more species not yet figured, have been sent home by Hartweg, of which details will be given in our succeeding Floricultural Notices.

Coniferaæ.

Pinus filifolia. Seeds of this magnificent new species, found by M. Hartweg in Guatemala, have been received by the Horticultural Society, but it is to be feared that it will not prove hardy. The leaves of this species are longer than those of any other previously discovered; and the branches are as stout, or stouter than those of *P. palustris* (*P. australis* *Michx.* and *Arb. Brit.*).

P. Coulteri. Dr. Lindley is of opinion that *P. macrocarpa* *Arb. Brit.* and *P. Coulteri* *Arb. Brit.* are different plants, and that the true *P. Coulteri* "seems to be still a desideratum in our gardens."

Orchidaceæ.

2540. ONCYDIUM
pachyphylum Hook. thick-leaved £ ☒ or 2 j Y.R Mexico 1839. O p.r.w Bot. mag. [3807.

This species "is remarkable for its large, thick, and very coriaceous leaf, and its ample panicle loaded with blossoms of a greenish yellow colour, spotted with orange and red purple, and not destitute of fragrance." It is also remarkable for having no evident stem, and no pseudo-bulb. It flowers in January. (*Bot. Mag.*, July.) Dr. Lindley states that this *Oncidium* is the same as *O. Cavendishianum* Bate.; see *Hort. Brit.*, p. 652.

O. pallidum Lindl. A Brazilian plant, with sea-green leaves, and a panicle almost a foot long; "very near *O. Harrisonianum*." (*B. M. R.*, No. 108., July.)

O. Hunnianum Hook. (see p. 344.) Dr. Lindley states to be the same as his *O. sanguineum*: see Vol. XV. p. 398.; and *Sert. Orchid.*, t. 27. (*B. M. R.*, No. 137., September.)

O. ramosum Lindl. A Brazilian species, with pale flowers in a large branched panicle, on a scape 5 ft. high. (*B. M. R.*, No. 154., Sept.)

2562. BRASAVOLA
venosa Lindl. veiny-lipped £ ☒ or 1 o W.G.V Honduras 1839. D p.r.w Bot. reg. 1840. [39.

This very fine species has the lip white and strongly veined, with the sepals green. "The flowers are deliciously sweet at night." It was imported from Honduras by Messrs. Loddiges, and is nearly allied to *B. nodosa*, (see p. 203.) "The leaf is intermediate between that of *B. glauca*, and the common terete species." (*Bot. Reg.*, July.)

glauca Bate. glaucous £ ☒ or 1 W.G.V Mexico 1837. D p.r.w Bot. reg. 1840, 44.

A splendid plant with a white and green flower, stained with yellow, greatly resembling that of a cattleya. The flowers are very large, and the plant is generally found on oaks (see p. 345.). The species is rather difficult to cultivate, so as to make it flower; but Mr. Fortune has found that, by destroying or keeping back the leaf bud that forms at the base of every flower bud, the latter may be induced to expand. The leaves of this species are large and broad, and very luxuriant. (*Bot. Reg.*, August.)

2532. ZYGOPETALUM
africanum Hook. African £ ☒ or 1 d Va Sierra Leone 1839. D p.r.w Bot. mag. 3812.

This plant, Sir W. J. Hooker states, was "sent by Dr. Whitfield from Sierra Leone to the Woburn collection;" but Dr. Lindley asserts that the plant "is certainly American, and, in all appearance, is a pale variety of *Odontoglossum bictoniense*, the *Cyrtochilum bictoniense* of Mr. Bateman's work." (*Bot. Mag.*, July; and *B. M. R.*, No. 139., September.)

3603. MYANTHUS spinosus Hook. (See p. 344.)
Synonyme: *Catasetum spinosum* Lindl.

This plant, Dr. Lindley states, is a *Catasetum*. (*B. M. R.*, No. 136., Sept.)

3597. MONACHANTHUS ruseo-albus Hook. (See p. 296.)
Synonyme: *Catasetum ruseo-album* Lindl.

Dr. Lindley observes of this species: "As the genus *Monachanthus* is suppressed, I am obliged to alter the designation under which the plant has appeared in the *Bot. Mag.*" (*B. M. R.*, No. 135., September.)

longifolius Hook. long-leaved £ ☒ or 1 Y.R Mexico 1839. D p.r.w Bot. Mag. 3819.
Synonyme: *Catasetum longifolium* Lindl.

A splendid plant with golden yellow flowers. (*Bot. Mag.*, September.)

2530. CATASETUM
integerrimum Hook. very entire-lipped £ ☒ or 1 Y.B.G Guatemala 1839. D p.r.w Bot. [mag. 3823.

There are two forms of this species :

α purpurascens, flowers with a purplish tinge.
β viridiflorum, flowers with a greenish tinge.

A splendid plant, sent by Mr. Skinner, from Guatemala, to the late Duke of Bedford. "The species is a very distinct one, having a lip with the mouth considerably contracted, and quite entire." (*Bot. Reg.*, September.)

Catasètum dell'òideum. Dr. Lindley has had a scape of this plant sent to him, the flowers of which had become of exactly the same form as those of *Monachánthus viridis*; thus affording an additional proof that this supposed genus is only another form of *Catasètum*. (*B. M. R.*, No. 157., September.)

3582. **LÆLIA**
rubescens Lindl. blushing £ ☒ or ½ my Pk D p.r.w Bot. reg. 1840, 41.

This species has been already mentioned (p. 203.). The flowers are smaller than those of any other species of the genus, and they are without fragrance. "In the specific character originally given, the bracts were described as pubescent. This appearance arises from the presence of minute patches of extremely delicate hairs, which soon wither up, and leave nothing but a stain, to indicate their having been present." (*Bot. Reg.*, July.)

Epíphora pubescens Lindl. An epiphyte from South Africa, with "fragrant bright yellow flowers streaked with red. It approaches very near to the genus *Polystachya*." (*B. M. R.*, No. 103., July.)

Cirrhopétalum picturátum G. Lodd. An Indian plant, with umbels of purple flowers, deeply stained with dark red. (*B. M. R.*, No. 106., July.)

C. aurátum Lindl. Differing from the preceding species in the flowers being larger, and "fringed with golden yellow hairs." (*B. M. R.*, No. 107., July.)

Stanhòpea Martiàna Bate. A splendid plant from Mexico, named in honour of Professor von Martius. (*B. M. R.*, No. 109., July.)

S. gravèolens Lindl. A Peruvian species, with the habit and general appearance of *S. saccàta*, but far handsomer. The fragrance is heavy and overpowering. (*B. M. R.*, No. 125., August.)

2547. **DENDROBIUM**
Devoniànum Paxt. Duke of Devonshire's £ ☒ or 1 [p.r.w Paxt. mag. of bot. vii. p. 169. ap my Y.P Khoseea 1837. D

One of the most splendid of this magnificent family, but most nearly allied to *D. æmulum*. (*Paxt. Mag. of Bot.* September.)

29821 *ámplum* Paxt. *Mag. of Bot.*, vii. p. 121.

D. revolutum Lindl. An Indian species, with straw-coloured flowers; very distinct. (*B. M. R.*, No. 110., July.)

D. tères Lindl. "A slender plant, with the leaves of *Vanda teres*, and whitish fragrant flowers, in terminal naked racemes." (*B. M. R.*, No. 111., July.)

D. herbàceum Lindl. A small East-Indian plant, with "inconspicuous green flowers." (*B. M. R.*, No. 153., September.)

Dinèma paleàceum Lindl. A Guatemala plant, with pale straw-coloured flowers. (*B. M. R.*, No. 112., July.)

Dendrochìlum filifòrme Lindl. "The first living specimen seen in Europe, of Blume's genus *Dendrochilum*." The genus is allied to *Líparis*. (*B. M. R.*, No. 113., July.)

2553. **CATTLEYA**
Aclándæ Lindl. Lady Acland's £ ☒ or ½ jl P.G Brazil 1839. O r.w Bot. reg. 1840, [48.

A very handsome species, with a large purple lip and column. The flowers are darker than in most of the other species. (*Bot. Reg.*, August.)

Blèia secúnda Lindl. A Mexican species, with green flowers dotted with crimson, and a straw-coloured labellum. (*B. M. R.*, No. 120., August.)

Trigonídium ringens Lindl. A Mexican plant, with fine deep green pseudo-bulbs and leaves, and insignificant scentless flowers. (*B. M. R.*, No. 121., August.)

Epidéndrum (Encýclia) bractescens Lindl. "The pseudo-bulbs are exactly ovate, closely clustered, and about as large as a pigeon's egg. The flowers have a beautifully but delicately painted white lip, the gay effect of which is heightened by the contrast with the dingy purple of the long narrow sepals and petals." (*B. M. R.*, No. 122., August.)

E. amphiglottis Trinitatis Lindl. A Trinidad plant, with yellow green flowers. (*B. M. R.*, No. 128., August.)

E. densiflorum Hook. (see p. 295.) This species Dr. Lindley considers the same as the *E. floribundum* of Humboldt et Kunth. (*B. M. R.*, No. 134., August.)

E. lancifolium Lindl. A Mexican species, very like *E. cochleatum*, but with a striated lip. (*B. M. R.*, No. 152., September.)

Sarcanthus oxyphyllus Wall. This proves, Dr. Lindley informs us, to be only a narrow-leaved variety of *S. rostratus*. (*B. M. R.*, No. 123., August.)

Aporon leonis Lindl; A. indivisum Blume. This plant was at first supposed to be the *A. indivisum* of Blume; but it proves to be a distinct species. It is called, in Singapore, the lion's mouth. (*B. M. R.*, No. 127., August.)

Cleisostoma latifolium Lindl. "A vanda-like plant from Singapore." (*B. M. R.*, No. 127., August.)

Chysis lævis Lindl. This species has very large yellow flowers, the lip of which is spotted with dull brown; and it is remarkable for its column becoming hard and tumid after fertilisation. (*B. M. R.*, No. 130., August.)

C. bractescens Lindl. This "species has white flowers, with a deep yellow fleshy lip, which is divided into two lobes, each folded twice, so as to give the whole the appearance of being 4-lobed." (*B. M. R.*, No. 131., August.)

GALEA'NDRA (*Galca*, a casque, and *anēr*, an anther; in allusion to the crested anther.)

Baueri Lindl. Mr. Bauer's $\text{£} \square$ or $\frac{1}{2}$ au P Guiana 1839. O s.p Bot. reg. 1840, 49.

A very curious and rather handsome plant, which, in its native state, appears to range over "an unusual extent of country, the South of Mexico on one hand, and French Guiana on the other, being its northern and southern limits." (*Bot. Reg.*, September.)

2521. RODRIGUE'ZIA

crispa Lindl. crisped $\text{£} \square$ cu 1 o G Brazil 1839. O s.p Bot. reg. 1840, 54.

This species is remarkably fragrant, having the scent of primroses. Its flowers are green, and curiously crisped (see p. 22.). It may be grown either in a pot or on a block of wood. (*Bot. Reg.*, September.)

Sarcophilus unguiculatus Lindl. "The flowers are light straw-colour, the side lobes of the labellum white streaked with crimson, and the middle lobe round, fleshy, and dotted with crimson." It is a native of Manilla. (*B. M. R.*, No. 143., September.)

Maxillaria Skinneri Lindl. This species has flowered at Penrhyn. "It has very much the appearance of a large form of *M. aromatica*, but the structure of the flowers is different." (*B. M. R.*, No. 145., September.)

M. Macleii Bate. "This plant is nearly related to, but undoubtedly distinct from, *M. tenuifolia*." It is a native of Guatemala, whence it was sent home by Mr. M'Klee, after whom it is named. (*B. M. R.*, No. 155., September.)

Pleurothallis pachyglóssa Lindl. A very large-flowered species of the genus. A native of Mexico. (*B. M. R.*, No. 146., September.)

Angraecum bílobum Lindl. An African epiphyte, with long drooping racemes of white flowers, just tipped with pink, and sweet-scented. (*B. M. R.*, No. 151., September.)

3642. SACCOLA'BIUM

denticulatum Part. toothed $\text{£} \square$ cu $\frac{1}{2}$ ap W Khoseea 1837. O r.w Part. mag. of bot. [vii. p. 146.]

A curious plant from the Khoseea Hills, which requires to be grown on a block of some kind of wood. "Logs of the common robinia seem to be preferred in the London collections; and, where cork-wood can be procured, it is unquestionably the best." (*Part. Mag. of Bot.*, August.)

Iridæcæ.

142. IRIS 1312 reticulata *Bot. Gard.* 748.

144. MA'RICA 1337 humilis var. lutea *W. Herb.* Bot. mag. 3809.

Synonyme: *M. lutea Hort.*

Amaryllidææ.

Sprekèlia glauca. "A beautiful new jacobæa lily, discovered in Mexico by

M. Hartweg, with narrow, glaucous, and pale flowers." (*B. M. R.*, No. 104., July.)

Asphodelaceæ.

1046. *A'LLIUM* 28591 *azùreum Ledebour.*

Synonymes : *A. cæruleum Pallas*, *A. cærulescens G. Don* ; *Bot. Reg.* 1840, 51.

Commelineæ.

1000. *TRADESCANTIA*

tumida Linal. tumid $\frac{y}{\Delta}$ or 1 s R Mexico 1839. D co. *Bot. reg.* 1840, 42.

A very curious plant from Mexico, with reddish flowers and deep green leaves, which are purple on the under side when young, and which are rolled back in a very singular manner when full grown. The stem is still more remarkable, as the joints are swelled and tumid. It is half-hardy, and "grows freely in sandy loam, but is very apt to suffer from damp in winter." (*Bot. Reg.*, July.)

SPIRONEMA (*Spira*, a spire, *nema*, a thread ; in allusion to the spiral threads that occupy the interior [of the filaments.]
frâgrans Lindl. fragrant $\frac{y}{\Delta}$ cu 1 my W Mexico ? 1839. D co. *Bot. reg.* 1840, 47.

A very curious rush-like plant, with small but very fragrant flowers. (*Bot. Reg.*, August.)

REVIEWS.

ART. I. *Annales des Sciences Physiques et Naturelles, d'Agriculture et d'Industrie, publiées par la Société Royale d'Agriculture de Lyon.* Tomes I. and II., and Livraisons 1, 2, and 3. of Tome III. Lyons and Paris, 1838, 1839, and 1840.

LIVRAISONS 1, 2, and 3. of tome i. are reviewed in our volume for 1839 p. 168., where we have characterised the work as one of the most respectable of the kind published in France. We now, therefore, commence at the point where we left off, and shall notice whatever appears to us of direct interest to gardening, agriculture, and domestic improvement.

At the *séance* of June 14. 1838, Professor Audouin, of Paris, gave an account to the Society of his Researches for the Destruction of the *Pyrale*, a species of moth, which is so injurious to the vine in France as frequently to destroy the crop through entire districts. After an extremely interesting history of his experiments, and of the very singular manner in which the eggs of the female are fecundated, M. Audouin states that the mode of destroying the insect which he found most effective is, to place among the vines, in the nighttime, lamps enclosed in glass, and suspended over a saucer of oil, or any greasy or viscous matter. The moth flies to the light, which it is prevented from touching by the glass of the lamp, while, by repeatedly striking against it, in its endeavours to get at the light, it drops down and is drowned or fixed in the oil or greasy matter. One cultivator, in the year 1837, put down in his vineyards, in one night, 200 of these lamps, at 25 ft. apart every way. The lamps burnt for about two hours, during which time an average of 150 moths were fixed in each saucer, making in all 30,000 insects. A fifth part of that number of moths consisted of females, each of whom would have laid 150 eggs, which in a few days would have produced 900,000 caterpillars. August 7th, 180 lamps, placed in the same vineyard, and for the same period, caught each 80 moths, making in all 14,400 insects, three fourths of which were females ; but admitting only the half, or 7,200 females, in multiplying this number by 150, the number of eggs that each female is supposed to lay, the total number of caterpillars destroyed will be 1,080,000. Another mode which M. Audouin recommends is, gathering the leaves, or the points of the shoots, immediately after the eggs have been deposited, or when they have been newly hatched. As the eggs are always laid upon the upper surface of the leaf, they are easily detected by women or children. By this process 20 persons, between the 7th and 11th of August, gathered

1840. Oct.

186,900 nests of eggs, and, as each nest contains, at an average, about 60 eggs, the total number destroyed was 11,214,000.

This subject is, no doubt, of far more interest to the Continental *vigneron* than to the British gardener; but, still, we think that the latter might adopt both the lamp and the gathering systems among his cabbages and gooseberries. At all events, a knowledge of what has been done in France will tend to enlarge his mind on a subject intimately connected with his profession. This important discovery of M. Audouin is about to be published, under the auspices of the French government, in a work which will be entitled *Histoire des Insectes nuisibles à la Vigne*, which we shall elsewhere notice. The peculiar merit of M. Audouin as an entomologist is, that he directs his attention in a particular manner to the insects injurious to agriculture, unlike many others who occupy themselves solely with classification and nomenclature.

The Seed of the *Orobánche minor*, which is very small, and attaches itself to the seeds of clover, hemp, and tobacco, may be removed from these seeds by thorough washing and rubbing in water, and afterwards powdering the washed seed with ashes to render it dry and fit for sowing. (tome i. p. 430.)

On the Improvement des Fosses d'Aisances; by Dr. Bottex. This is a very scientific paper, in which the subject is first treated chemically, and next the progress of improvement in this department of architecture and domestic economy is traced from the year 1786, when the architect Giraud of Versailles proposed certain changes, to the invention of M. Caseneuve in 1818, which was exhibited in London, in Gerrard Street, Soho, in the year following. The chloride of lime is recommended as the best disinfecting substance, and it is also stated, that stercoraceous matters may be disinfected with river mud carbonised, with peat-ashes, with sawdust, with tan, or with various other substances; in short, it is only necessary to carbonise a mixture of argillaceous soil with fæcal matter, in order to obtain a perfect disinfected powder. Hence the vapours from all manner of dunghills, when too near a house, may be rendered innocuous, by covering or mixing them with loamy soil, and more particularly with cleanings of ditches or ponds.

To preserve Corn for several Years, sink it in the earth, where it will not undergo change of temperature, and where the temperature will be so low as not to admit of hatching the eggs of insects. Air and moisture must also be completely excluded. (tome i. p. 473.)

Report on the Domain of M. Nivière, a scientific farmer, who keeps his farm in the very best order, and is remarkably exact with his accounts.

Morus Seringeana (in compliment to the director of the botanic garden of Lyons) has been raised from seed of *Morus multicaulis*, and is considered preferable to that variety, from its hardness and the largeness of its leaves. The fruit is small, and of a dark violet colour.

A hybrid *Chrysanthemum*, between the Chinese species and *Chrysanthemum leucanthemum*, and a specimen of a double-flowered Melon Plant, were presented to the Society. All the flowers of the melon plant, from which the specimen was taken, were double and sterile. (p. 492.)

Flat Clay Roofs have been formed in Germany, and described in a pamphlet published in Brunswick in 1837, entitled, *Der Bau der Domschen Lehmdächer &c.*, and the essence of which is here given. Clay, tan, coal tar, Burgundy pitch (*résine de Bourgogne*), and sand, or powdered bricks, are mixed together and beaten till the entire mass is homogeneous, and may be readily spread by the hand or a trowel. It is then spread on the roof, or on balconies or terraces. Owing to the lightness of the timbers which may be employed, this kind of roof is found to be much cheaper than one of tiles, and the experience of six or eight years seems to show that it will be durable. (p. 503.)

Morus multicaulis was killed to the ground in the neighbourhood of Lyons, and in various places in Languedoc, during the winter of 1837-8. (p. 536.)

Theory and Application of Labours on the Soil. This is an excellent paper, and well worth translating for an agricultural journal. After describing the different kinds of labour, such as those for turning up and mixing the soil, viz. digging and ploughing; those for stirring the surface or destroying weeds,

such as hoeing and raking; and those for deepening the soil, such as trenching and double ploughing; he treats of the different modes of performing each, and the advantages and disadvantages of different modes of performance; taking into consideration manure, climate, crop, &c. He strongly recommends deep digging and ploughing, which in fact is the greatest improvement wanted in France, owing to the dryness of the climate, both in agriculture and gardening. (tome ii. p. 11.)

Manure given to Vineyards is found to injure the quality of wine made from the grapes, more particularly horn shavings, which are used in the immediate vicinity of Lyons. Some contend that the odour of the dung is absorbed by the pellicle of the fruit; others by the leaves, of which opinion M. Seringe is an advocate; and others by the root. (tome ii. p. 101.)

Rhizoctonia Medicaginis Dec., a fungus which infests the roots of lucern, is described by M. Seringe as extending in a circle all round the plant, so as to attach itself to the roots of the others which it meets in its course. *R. Crocorum Dec.* infests the roots of the saffron crocus in England. (tome ii. p. 105.) *Cuscuta minor* is also very injurious to lucern in France, as the *C. europæa* frequently is to the hop in England.

A new double mould-boarded Plough, invented by M. Reverchon, is examined by a commission and favourably spoken of. The chief object is to save time, in changing the mould boards at the ends of the furrows, for which purpose there are as it were two ploughs, one placed exactly over the other; and the business of the ploughman, at the end of the furrow, is simply to turn the plough upside down before he reenters it. The name given to this implement is *Charrue jumelle*, twin plough. (tome ii. p. 167. t. 5.)

Notice on the Species of *Calceolaria*, cultivated in the Royal Flower-Garden at St. Cloud, by M. Charles Gondouin. M. Gondouin arranges the *calceolarias* in two sections; the first containing *C. plantaginea* and *C. pinnata*; and the second *C. rugosa*, *C. arachnoïdea*, and their numerous varieties, cross-breeds, or hybrids, amounting to sixteen, which are described. M. Gondouin recommends the seeds of *calceolarias* to be sown in pans of light earth, and placed in a hot-bed in February, when, if properly treated, they will flower vigorously the same autumn, and the expense of keeping them through the winter will be avoided, or rendered much easier than that of preserving seedlings sown in autumn. (tome ii. p. 173.)

The Roots of *Ænothëra biennis L.* (*Onagre, French*) are eaten in Germany like those of *scorzonera*, and the points of the shoots may be used in salads. The herbage would form a good forage for cattle, which are very fond of it. (tome ii. p. 180.)

Les Sommeliers, a new variety of potato, is recommended by M. Pepin, who has propagated the London leek (*Poireau gros-court*) for several years without seeds, by cutting it over 6 or 8 lines above the plate from which the roots spring, and planting the suckers which are in consequence produced. (tome ii. p. 182.)

Essai sur la Théorie de l'Aménagement des Forêts; by M. Noirotonnet. By *aménagement* is meant such an arrangement as, in the case of any given forest, will insure an equal produce every year while the forest lasts. The first point to ascertain is, the number of years which the wood of the forest requires to attain its most profitable age; and the next point is, to divide the forest into a corresponding number of portions. It is evident that the great difficulty is to determine the profitable point, all the circumstances being taken into consideration, of markets, reproduction, &c. In his first chapter the author treats of the increase of timber, and he arrives at the conclusions following:—Hard woods, such as oaks and beeches, may be most profitably cut down at an age between 140 and 160 years. Resinous woods, such as spruces and silver firs, 110 to 120 years; and such as pines and larches, 70 to 80 years. White woods, such as maples, sycamores, ashes, and elms, 100 to 110 years. Soft woods, such as birches and alders, from 55 to 65 years. This supposes, which the author believes to be the case, that it is in the

state of timber, and not in that of coppice wood, that forests give their maximum of produce. As we contemplate an abridgement of this most excellent article, we shall take no farther notice of it at present.

M. Seringe, who had thought that the appearance of *Cytisus purpureus* on *C. Laburnum* was the result of some trick, is now convinced that this singular anomaly is in nature, but he gives no explanation. (tome ii. p. 377.)

The idea of procuring silk directly from the bark of the mulberry, which Olivier des Serres had discovered and published in 1603, is discussed; and also that of forming woollen cloth by means of strong pressure of wool on a base of caoutchouc. (tome iii. p. 8.) This has been done in England by Mr. Calvert, formerly nurseryman at Rouen.

Diluted sulphuric acid has been found equally efficacious with gypsum in the culture of clover. (tome iii. p. 15.)

Seeds of *Péganum Harmala* L., *Rutàcæ*, a herbaceous perennial plant, a native of the Crimea, which produces a dye thought to rival that of the cochineal, were received from Professor Mirbel of the Jardin des Plantes, in order to be distributed among the more zealous and enlightened cultivators. (tome iii. p. 27.)

On the Organisation of the Anthers of Mosses, &c.; by M. Seringe. (tome iii. p. 229.)

ART. II. *Icones Plantarum rariorum Horti Regii Botanici Berolinensis.* Figures and Descriptions of rare Plants in the Royal Botanic Garden at Berlin. By H. F. Link, Fr. Klotzsch, and Fr. Otto. Part I. 4to, pp. 16, 6 coloured plates. Berlin, 1840. Price 1½ rix-dollars; about 4s. 6d.

The following address will show the intention of the authors of this new pictorial botanical periodical:—

“Our work will only treat of such new or rare plants as are remarkable for their beauty, which have not yet been made known or figured; and each number will contain so many details, that, by a single glance at a plate, and without even looking at the text, the natural order, the class and order of the Linnæan sexual system, and the genus and species may easily be known. The text will be in the Latin and German languages, in which the essential characteristics of the natural orders, tribes, genus, and species will be given; also those that are nearly allied to them, with a full description of the latter, the most suitable method of cultivating each plant, its native country, by whom discovered, &c.”

In an address by the publisher, he states that the names of Link, Klotzsch, and Otto guarantee the excellence of the work; that Professor Kunth has also kindly promised his assistance, and that the “celebrated artist” Schmidt, who makes the original drawings, has also undertaken the superintendance of the lithography and the colouring.

The plants figured in the first Number are:—*Puya Altensteini*, *Bromeliacæ*, from South America, not yet introduced into England, we believe. *Lobelia discolor* from Mexico in 1838, not yet in England. *Olinia capensis* Klotzsch, *Myrtacæ*, a Cape shrub which has been many years in Germany under the name of *Cremastostemon capensis* Jacq., but neither of which names occurs in British catalogues. *Oxalis Ottònis* Klotzsch, sent by Edward Otto, the son of the director, from Cuba, and figured in 1837 in the *Floral Cabinet* as *O. geniculata* Kn. et W., and recorded under this name in the Supplement to our *Hortus Britannicus*: on comparing the figures there can be no doubt of their being the same plant, and hence the Birmingham name must take precedence of the other. *Micròstylis histionantha*, *Orchidacæ*, sent from La Guayra to Berlin in 1836. *Oncidium carthaginense* Swartz, *Orchidacæ*, sent from Maracay to Berlin in 1837 (*Bot. Mag.*, t. 777.), introduced into England in 1791. The figures are accurately and artistically drawn and exquisitely coloured. Nothing of the kind, as it appears to us, can be more perfect.

The plants which will be figured in Part II. are, *Begonia punctata*, *Asterotrichion sidoides*, *Malvaceæ*; *Hohenbergia strobilacea*, *Sisyrinchium majale*, *Spiranthes Lindleyana*, *Lennæa umbellata*, *Pittosporaceæ*.

ART. III. *A Pocket Dictionary, comprising the Names, History, and Culture of all Plants known in Britain; with a full Explanation of technical Terms.* By Joseph Paxton, F.L.S., H.S., &c., assisted by Professor Lindley, Ph.D., F.R.S., &c. 8vo, pp. 354. London, 1840. Price 15s.

In order to give our readers a clear idea of what this book is intended to be, we shall quote from the preface; and afterwards, in order to show what it is, we shall give a specimen page.

It is certainly a great comfort to a conscientious author, when the book he produces does not interfere directly with any other work of the kind already in circulation. Hence Mr. Paxton observes: "When an author offers to the public a work, the greater part of the information contained in which is already available in detached fragments or other forms, his first duty is to exhibit the propriety of its publication; and prove, beyond question, that he has been instigated to his task by no unworthy desire of fame, but by a distinct and certified persuasion of its demand and utility.

"Happily, in the present case, we are enabled to court scrutiny into our motives, being fully prepared to explain and justify them. During the numerous interviews enjoyed by us with the leading patrons of floriculture, the want of a pocket companion, such as that now furnished, has ever been especially and forcibly urged. There are, it is true, catalogues, encyclopædias, lexicons, and cultural directories, all highly valuable in their respective spheres; and essential adjuncts to a gardener's or amateur's library; but they are too elaborate, verbosè, technical, or uninteresting, to be readily and thoroughly appropriated. The expense, also, of several is necessarily enormous, and beyond the means of the great majority of those who thirst after botanical and floral literature; and no single one, much less set, embracing all the subjects of this Dictionary, is conveniently portable, or can even be carried, without discomfort, beyond the porch of the proprietor's domicile.

"Comprehensive compendiums, in which scientific and popular details are abridged, combined, and thus brought within the pecuniary reach as well as easy examination of those whose income and time are subjected to many other more pressing exactions, are highly commendable if attentively and clearly arranged; but their usefulness is in proportion to the precision and accuracy of the manner in which they are compiled.

"THE POCKET BOTANICAL DICTIONARY, then, has been prepared solely as an instant resource, and standard of consultation; and, for this purpose, will be found invaluable to the professors and lovers of horticulture, in all its branches, and of every grade. Within its columns is compressed all the most important information, relative to admired plants, which its small size and avowed design would admit. With this in his pocket the possessor or cultivator of plants may perambulate his own garden, visit those of his friends or public establishments, and attend floricultural exhibitions, in the full assurance that if any particular object engage his attention, he may at once derive every fact of interest respecting both it and its congeners, which is yet known in this country, and form an idea of the facility or difficulty, and consequent expense, attending its conservation. Such is, cursorily, the prime purport of this publication, and the aim of its author." (p. vi.)

We are indebted to the publisher for the following specimen page, in which the reader will observe how effectively Mr. Paxton and Dr. Lindley have attained their object, and how truly useful this Dictionary will be to an immense number of persons. We have not a single objection to the work, unless it be that the type, notwithstanding its clearness, is somewhat too small for our eyes.

DEC	DEL	DEL	DEN
DECUMBENT, lying down.			
DECUMBENS, running down.			
DECUMBENS, having a tendency to run down.			
DECUSSATE, when two right lines cross each other at right angles, they are said to be decussate.			
DEKROONIA, R. Brown. In memory of Dr. Charles Deering, an English botanical author. <i>Linn. 5, Or. 1, Nat. Or. Amaranthaceae.</i> Curious but weak-growing plants. The seed requires to be sown in a hot-house, or hot-bed, and when of sufficient size, the plants may be putted off, and placed among the stove plants.			
celosideifolia	White	9, S. B. E. Ind.	1804
indica	White	10, S. B. E. Ind.	1804
DEFLEXED, turned downwards.			
DEFOLIATUS, deprived of leaves.			
DEGRAPHS, Trinius. Derived from <i>dis</i> , twice, and <i>grapho</i> , to mark. <i>Linn. 3, Or. 2, Nat. Or. Gramineae.</i> Worthless species of grass, growing in any common soil, and increased by divisions at the roots. <i>Synonymes: 1. Phalaris arundinacea. 2. Arundo cotula—americana 1, arundinacea 2, variegata.</i>			
DEHISCENT, gaping; an expression applied to the mode in which the anthers or the fruit burst open, and discharge their contents.			
DELSSEYI, Lamour. In honour of M. Benjamin DelSSERT, a famous French botanical patron. <i>Linn. 24, Or. 7, Nat. Or. Algae.</i> Beautiful species, of mostly deep green <i>Algae</i> , found in the ocean, and on the sea-shore. <i>Algae, angustifolia, A. dilatata, Bonnemaisonia, glandulosa, hypoglossatum, laevigata, ocellata, Plocamium, punctata, ruscifolia, sanguinea, sinuosa.</i>			
DELTOIDA, Linn. From <i>deltois</i> , to fill, or shave off; the leaves are used for polishing. <i>Linn. 13, Or. 1, Nat. Or. Dilleniaceae.</i> Very fine climbing plants, growing best in loam, peat, and sand mixed; ripened cuttings root in sand, under a glass, in heat.			
nitida	Yellow	S. Fr. Cl. Trinidad	1830
sarmentosa, 1	Yellow	S. Fr. Cl. Ceylon	1820
DELISQUESCENT, melting away upon exposure to air.			
DELPHINUM, Linn. From <i>delphinus</i> , a dolphin; in reference to the supposed resemblance in the nectary of the plant to the imaginary figures of the dolphin. <i>Linn. 13, Or. 3, Nat. Or. Ranunculaceae.</i> All the species of Larkspur are showy, and valuable as border flowers, especially <i>D. Ajacis</i> and <i>Consolida</i> , both of which are universally grown among the border annuals. The herbaceous and perennial kinds are increased by divisions, or seeds, and the annual and biennial kinds merely require sowing in the open border, where they will flower and seed freely. <i>D. Consolida</i> is regarded as a simple astringent. <i>Synonymes: 1. D. tridactylon. 2. D. hirsutum. 3. D. intermedium. 4. D. junceum. 5. D. ambiguum.</i>			
Acemil	Purple	6, H. A. Levant	1801
Ajacis	Purple	6, H. A. Sward	1873
flor-plenit	Varieg.	6, H. A. Europe	1873
albiflorum	White	7, H. Her. P. Armenia	1823
alpinum	Blue	7, H. Her. P. Hungary	1818
altissimum	Blue	7, H. Her. P. Alsacia	1829
ambiguum	Blue	6, H. A. Barbary	1759
anacardium	Pa. blue	7, H. Her. P. Siberia	1818
arvense	Lgt. blue	7, H. Her. P. Carolina	1805
Barbottii	Pa. blue	8, H. Her. P. Eng. hyb.	
cardiophyllum	Blue	6, H. A. Perennes	1818
cheilanthum	dk. blue	5, H. Her. P. Siberia	1819
multiflorum	Az. blue	7, H. Her. P.	
obtusissimum	Blue	7, H. Her. P. China	1819
Consolida	Blue	4, H. A. England	
flor-plenit	Varieg.	6, H. A. England	
cuneatum	Blue	6, H. Her. P. Siberia	1818
dasycaepum	Blue	7, H. Her. P. Caucasus	1819
dilatatum	Blue	7, H. Her. P. Siberia	1817
elatium	Blue	7, H. Her. P. Siberia	1807
elegantissimum	Blue	7, H. Her. P. N. Amer.	
flor-plenit	Blue	7, H. Her. P. N. Amer.	1741
flexuosum, 1	Blue	7, H. Her. P. N. Amer.	1738
fixatum	Blue	6, H. Her. P. Hungary	1816
flexuosum, 2	Blue	5, H. Her. P. Caucasus	1820
grandiflorum	Dk. blue	7, H. Her. P. Siberia	1816
albium	White	7, H. Her. P. Gardens	1816
flor-plenit	Dk. blue	6, H. Her. P.	
pellidum	Blue	6, H. Her. P. Gardens	1820
hybridum, 2	Blue	7, H. Her. P. Siberia	1794
intermedium	Blue	6, H. Her. P. Silesia	1710
coralloides	Lt. blue	7, H. Her. P.	1836
laxum	Blue	6, H. Her. P.	
leptoclychium 3	Blue	5, H. Her. P. Pyrenees	
pellidum	Blue	6, H. Her. P.	
pileosolum	Blue	7, H. Her. P. Siberia	1836
raunseifolium	Blue	7, H. Her. P. Pyrenees	
asphirium	Blue	7, H. Her. P.	
lasiotum	Blue	7, H. Her. P. Siberia	
Menziarii	Blue	7, H. Tu. P. N. Amer.	1826
mesoleucum	Blue	7, H. Her. P.	1822
montanum	Blue	7, H. Her. P. Switzerl.	1819
heuteotidum	Blue	6, H. Her. P. S. Eur.	1816
ochroleucum	White	6, H. Her. P. Iberia	1823
Oliverianum	Blue	6, H. A. S. Eur.	1826
palmatifidum	Blue	7, H. Her. P. Siberia	1824
glabellum	Blue	6, H. Her. P. Siberia	1817
pergrinum	Blue	7, H. Her. P. S. Eur.	1819
pletium	Lgt. blue	6, H. B. S. Eur.	1816
psidium-pergrinum	Red	6, H. Her. P. Siberia	1823
pubescens, 5	Blue	8, H. A. Meditar.	1818
punctatum	Purple	7, H. Her. P. Siberia	1785
Requienii	Blue	7, H. B. Majorca	1824
revolutum	Pa. blue	4, H. Her. P.	
speciosum	Blue	7, H. Her. P. Caucasus	1816
spiratum	Blue	8, H. Her. P. Siberia	1810
Staphyleoides	Lgt. blue	7, H. B. S. Eur.	1596
tenussum	Purple	8, H. A. Greece	1835
tricornis	Blue	7, H. Her. P. N. Amer.	1806
triale	Blue	7, H. Her. P. Dalmatia	1829
ureclatium	Blue	6, H. Her. P.	1901
velutinum	Blue	7, H. Her. P. Italy	1819
villosum	Blue	7, H. Her. P. Caucasus	1818
viridulum	Blue	8, H. Her. P. N. Amer.	1835
virgatum	Blue	6, H. A. Syria	1823
DELTA-LEAVED, shaped like the Greek Δ.			
DELTOIDES, triangular.			
DEMATEUM, Persoon. From a diminutive of <i>dema</i> , a bundle; in reference to the mode of growth. <i>Linn. 24, Or. 9, Nat. Or. Fungi.</i> An extremely minute species of <i>Fungi</i> , of a bluish colour, found on the stems of herbs in autumn— <i>articulation</i> .			
DEMOLESCENT, having the property of softening anything.			
DEMYRIFERUM, Swartz. From <i>dendron</i> , a tree, and <i>bios</i> , life; in the places of their natural growth, the species are generally found upon trees. <i>Linn. 20, Or. 1, Nat. Or. Orchidaceae.</i> No orchidaceous plants contribute more to the gaiety of the stove, than the species of this splendid genus. <i>D. noble, chrysanthum, Gibsonii, flabratum, densiflorum</i> , and many others, are equalled by few, and certainly not surpassed, in the beauty of their flowers; by any other orchidaceous plants; and if the following directions be attended to, they will be found very easy of culture.—All orchidaceous plants require (to cultivate them successfully), a season of growth, a season of rest, and a season for flowering; all of which should coincide, as much as possible, with the corresponding seasons of these parts of the globe which they so profusely inhabit; and the species of this genus should especially be subjected to a change of treatment assimilating as much as possible to that before mentioned, without which, they will never flower in perfection. In India, three seasons only are known; the hot, or dry season, which is succeeded by the rainy season, and the cold, or winter season. In the hot season, all, or the greater part, of the plants belonging to this genus produce their flowers; in the rainy season, they make their shoots; and during the cold season, they have a period of repose. The different seasons being so well known, it is very easy to imitate them in our hot-houses, and by attending to these simple rules, we should be enabled to flower the species of this more abundantly than those of any other orchidaceous genus, besides which, they might be easily induced to flower in this country at any season of the year. <i>D. chrysanthum, Pierardii</i> , and some others, grow well when fastened singly on pieces of wood, and treated as is recommended under <i>Burlingtonia</i> ; but they all succeed well when potted in very turfy peat, raised above the pot, in the same way as is recommended in potting <i>Stanhopea</i> . A strong moist heat is indispensable in the growing season, when they may be frequently slightly syringed over-head. They will be found to succeed best in a warmer part of the house than the <i>Stanhopea</i> require. They are propagated by detaching one or more of the stems while in a dormant state, taking care not to injure the roots, and potting it carefully in turfy peat soil, and not much raised above the pot, which			

ART. IV. *A Flora of North America; containing abridged Descriptions of all the known indigenous and naturalised Plants growing North of Mexico; arranged according to the Natural System.* By John Torrey and Asa Gray. Parts III. and IV. 8vo, pp. 711. New York, 1840.

We noticed Parts I. and II. of this work in our preceding volume, p. 39.

and again in the present volume, p. 94. Parts III. and IV., now before us, complete Vol. I., and include all the Polypetalous division of dicotyledons. These parts bear, throughout, evidence of extraordinary research, care, and labour. By the preface it appears that almost all the principal herbariums in Europe have been examined, and that botanists in every part of North America have contributed specimens or information to the authors. It is difficult to conceive any work of the kind more complete, or in which all the information on the subject, up to the present time, has been so judiciously made use of; and still more difficult it is to comprehend how this first volume has been finished in so short a time.

Though this volume describes only about a fourth part of the American flora, yet we are astonished at the number of species, even of woody plants, which have not yet been introduced. We shall take our favourite genus, *Cratægus*, for example. Seventeen species are described, and of these 5, viz. *C. rivularis Nutt.*, *C. arborescens Ellis*, *C. æstivalis Torr. et Gray*, *C. berberifolia Torr. et Gray*, and *C. unilateralis Pers.* have not yet been introduced. It is gratifying to us to find that Drs. Torrey and Gray agree with us in considering many of the kinds treated as species by botanists to be only varieties; for example, *C. ovalifolia Horn.*, *C. linearis Pers.*, *C. prunifolia Bosc*, *C. flabellata Bosc*, &c.: but we cannot bring ourselves to believe that *C. sanguinea Pall.* and *C. Douglàsü Lindl.* are the same species; and we feel certain that, if Drs. Torrey and Gray saw the two plants together in a living state, they would be of our opinion. In truth, there is no certainty as to the names of species of plants, where the living plants have not been compared. Dried specimens, no doubt, make the nearest approach to living plants, and in many instances indicate the specific differences correctly; but, to be able to know whether they really do so or not, it is necessary first to have studied the living plant in its variations as well as in its normal state. What, for example, can be more distinct than specimens of different varieties of *C. Crús-gälli* or *Quercus Cérris*, if judged of only by specimens? And yet it is known to cultivators, that, by sowing the seeds of any one variety of these two species, most of the others may be procured. When all the species described by botanists shall be tested in this way, there will not be a tenth of them, perhaps not a twentieth, that will hold good. Nevertheless, what can botanists do better, in the meantime, than describe what they see? With the progress of civilisation, botanic gardens will be formed in all countries, and in these many wild species will disappear, and many crossbreds and hybrids be originated.

But we are forgetting the main object of this notice, which is to assure our readers that this is one of the most important botanical works for British gardeners that has ever been published; as extending an already prolific field of commerce for the nurseryman, and greatly increasing the resources of the shrubbery and the park.

The *Flora of North America* must find its way into the library of every botanist. It will, we trust, give rise to one grand national botanic garden in the United States, and to many collectors being despatched from Britain to send home the numerous species described which have not yet been introduced. We intend to take an early opportunity of giving a list of the trees and shrubs described in the first volume, which are not yet in British gardens.

ART. V. *Catalogue of Works on Gardening, Agriculture, Botany, Rural Architecture, &c., lately published, with some Account of those considered the more interesting.*

The American Flower-Garden Companion: adapted to the Northern States. By E. Sayers. 8vo, pp. 174. Boston, 1838.

A Treatise on the Culture of the Dahlia and Cactus. By E. Sayers. 12mo, pp. 72. Boston, 1839.

The Florist's Guide; containing practical Directions for the Cultivation of Annual, Biennial, and Perennial Flowering Plants of Different Classes, &c. &c. Third edition, enlarged and improved. By T. Bridgeman, Gardener, Seedsman, and Florist, New York. 8vo, pp. 180. New York, 1840.

The appearance of these three works, and the numerous agricultural and gardening newspapers now publishing in America, show the rapid progress which the arts of culture are making in that extensive country. Mr. Bridgeman's *Young Gardener's Assistant* is noticed in our Vol. XII. p. 193., and we observe that in a separate pamphlet he has published some extracts from the eighth edition of that work, which, though far from being new, yet appear to us of considerable interest, both in America and England, from the doctrine which they contain. This doctrine is, that the grand cause why fruit trees, and especially peach trees, are not so productive as they ought to be, is the result of their being too deeply planted. This secret was lately offered to the congress for a million of dollars, and Mr. Bridgeman says that he had anticipated it in the work referred to, and, as a proof of this, he publishes the extracts. The soil in America, he observes, is light; and the trees when planted in it, if not staked, are apt to be blown aside, or even blown out of the soil, by high winds. Hence, to avoid the trouble and expense of staking, they are planted deeper in the soil, which is the cause of unfruitfulness and disease in all trees, more especially in the peach. He repeats that this deep planting is practised not only with fruit trees in America, but with all trees whatever.

A Manual of Botany, comprising Vegetable Anatomy and Physiology, or the Structure and Functions of Plants. By W. Macgillivray, A.M., &c. 8vo, pp. 272, 16 plates. London, 1840.

This is one of a series of Manuals by an experienced and judicious author, who possesses a scientific as well as practical knowledge of the subjects on which he treats. The work has every appearance of having been prepared with great care and labour, and the steel plates are very neatly executed, though we should greatly have preferred them done on wood, and printed along with the text.

The Grammar of Botany. By G. Francis, F.L.S. 12mo, pp. 160, many wood cuts. London, 1840. Price 4s.

Of all the different miniature introductions to botany which have yet been published, this by Mr. Francis is, in our opinion, decidedly the best. It embraces as much as books of six times the size have attempted, and it explains the subject more clearly than these books and much more concisely, by means of woodcuts. It not only defines all the parts of plants, and all the principal terms used in botanical description, but it gives definitions and engravings of the flowers and fruit of forty-two natural orders of flowering plants, and of seven orders of Cryptogamia. We have often recommended introductions to botany to young gardeners, and many of these have been very excellent productions, every one vying with another in keeping pace with the progress of the age, but Mr. Francis's little work surpasses them all. We have not only to recommend this work to young gardeners, but to young amateurs of both sexes. That the author had in view its suitability for ladies, is obvious from the following passage in his preface.

"Two remarks it is necessary to make on the language employed throughout. One is, that the greatest simplicity has invariably been aimed at, particularly in the scientific names and words; and although the author has not fallen in this respect behind the spirit of the age, yet he has certainly not added to the puerility of it by new terms or new hypotheses, leaving such recondite matters to those who have more judgment than himself."

The second remark is this:—"The author has often had it objected to him, that botany is not adapted to young females, nor can it be introduced as a general subject of study in schools, because authors, in their introductory

works on the science, have led the mind to dwell chiefly on the sexual distinctions of vegetables, and that sexual organs, unisexual, hermaphrodite, and similar terms, are of common occurrence. It is not necessary to stop to enquire whether this objection be well founded, or whether all authors deserve the imputation. It is certainly to be lamented, that the science should be neglected by those for whom it is fittest from circumstances like these, especially as not one of the terms complained of is at all requisite, and not one of them has been introduced into the following pages."

Ricauti's Rustic Architecture. Parts III. and IV. Oblong, 4to, 14 plates. London, 1840. 6s. each Part.

We gave a notice of Parts I. and II. of this work in p. 355.; and Mr. Ricauti has, in p. 519., kindly corrected some errors that we fell into in that notice. The plates in the parts before us are most beautifully zincographed and printed, and the designs are in an eminent degree picturesque. We repeat what we before stated (p. 356.), that each part may be forwarded by post, and that in no cheaper mode could a gentleman procure a working plan for a very handsome ornamental cottage.—Part III. contains design No. III. a Gamekeeper's Cottage, equally suited for the residence of a small family. Estimate within 310*l.* Part IV. contains design No. IV. a Gardener's Cottage, equally suited for the accommodation of a small family. Estimate 385*l.*

If every proprietor of an estate exceeding 500 acres would execute on it but a single cottage of an ornamental character, and comfortable within, such as are exhibited in these designs of Mr. Ricauti, how much the country would be ornamented in appearance, and how much would be accomplished by the influence of example! Mr. Ricauti's designs are not of the cold heartless character, which were published by several architects of taste 15 or 20 years ago, in which all the skill of the architect was bestowed on the exterior, and the interior not a whit advanced beyond the state in which it was in the days of Holinshed. We refer to the reviews of certain works on cottages, given in our earlier volumes, for the truth of this remark. Happily for the cottager, the days when it was thought that the design for an ornamental cottage could only be given by first-rate architects is passing away; and from such books as this of Mr. Ricauti, our "Encyclopædia of Cottage Architecture," and various others, dwellings at once comfortable and ornamental may be erected by carpenters, bricklayers, and masons, in every part of the civilised world.

Illustrations and Description of Kilpeck Church, Herefordshire; with an Essay on Ecclesiastical Design. By G. R. Lewis, author of "British Forest Trees;" "An Address on Education as connected with Design, in every Department of British Manufactures;" and of various other Works. Part I. Fol. pp. x, 8 plates. London, 1840. Price, to Subscribers, 10s. 6*d.*

Letter to Thomas Phillips, Esq., R.A., on the Connection between the Fine Arts and Religion, and the Means of their Revival. By H. Drummond, Esq. 8vo, pp. 45. London, 1840.

Mr. Lewis has entered on his subject with a degree of enthusiasm that will charm some, and only draw forth a smile from others; and the same remark may be applied to Mr. Drummond's pamphlet. Nevertheless, in both productions there are a great many remarks in which every person endowed with common sense will concur. Whether we regard the plates most accurately drawn and lithographed by Mr. Lewis himself, or the singularity of the ideas in the letter-press, the work deserves a place in the library of the architect and the antiquarian. The coincidence of opinion on some points of sacred architecture, between Mr. Lewis and Mr. Drummond, is remarkable. The following sentence, from the latter gentleman's pamphlet, may be of use:—
"The castles in Germany and England, as well as the Saracenic in Spain

and Magna Græcia, were splendid buildings, both as respects their strength and picturesque effect; although it must be confessed, that the latter object was little, if at all, in the intention of the builders. It is in the architecture which is devoted to religious purposes, in the cathedrals and churches of England, that we find the real architectural superiority of this country, and not in the houses of her nobles and gentry, which are for the most part clumsy without grandeur, and poor without simplicity; and these defects are more visible in proportion as the national style has been departed from, and that of Italy imitated, as has been specially the case since the days of Inigo Jones." (p. 15.)

Architectural Precedents, with Notes and Observations. Edited by C. Davy, Arch., &c. Illustrated with working drawings. Parts II., III., IV., V., and VI. 8vo, pp. 108, 8 plates.

We noticed the first part of this work in p. 267.; and, the above parts being sent us, we earnestly and strongly recommend them to the young architect, and to the country gentleman who intends to build, as replete with useful information, and as being wholly practical.

Help to the Schoolmistress; or Village Teaching. By Emily Taylor. 12mo, pp. 98, 1 folding plate, and 1 page of diagrams. London, 1839.

Many of our readers patronise country schools, and the very title of this work and the name of the author, well known for her excellent school books, ought to recommend it to them. It contains well considered instructions to the schoolmistress, and a plan of a school, which any country carpenter or builder may execute at a moderate expense; being only 15 ft. long and 12 ft. wide. The diagrams are, a prize slate for a school of 49 children, and a prize book, both of which are very ingenious. Ladies who make tours to watering places, or, indeed, to any place, might do much good by taking a few copies of the *Schoolmistress* with them, and giving them away to village teachers.

ART. VI. *Literary Notices, prospective and retrospective.*

A GENERAL priced Catalogue of Implements, Seeds, Plants, &c., sold at the Agricultural Museum and Warehouse of W. Drummond and Sons, Seedsmen and Nurserymen. Stirling, 1840.

This catalogue will be found exceedingly useful to those that wish to know, not only the names of articles which are sold, but their prices. The only similar catalogue of the kind that we know of is Sang's of Kircaldy, noticed p. 93.

A Descriptive Catalogue of a Selection of Roses, cultivated for Sale by A. Paul and Sons, Nurserymen, Florists, and Seedsmen, Cheshunt, Herts, near London.

This catalogue is equal in merit to any that have been published. The enumeration of sorts fills 19 pages, and there are at an average above 50 sorts in a page; in all 950 sorts.

Catalogue for Autumn 1840, of an unrivalled Collection of Dutch and Cape Flower Bulbs, warranted genuine, imported and sold by James Carter, Seedsmen and Florist, No. 238. High Holborn, London.

The best catalogue of bulbs ever published in England. It is printed in a small type, on a very large page, so as to bring the weight within the penny postage. As this is the season for planting bulbs, we hope Mr. Carter will meet with that patronage which he so richly deserves.

Catalogue of Seeds, &c., sold by Drysdale and Lawson, Seedsmen, Nurserymen, and Florists, New Seed Warehouse, Glasgow, is noticed as being the

production of beginners, who are strongly recommended for their activity, industry, and integrity. They have another catalogue of Trees, Shrubs, and Herbaceous Plants of select sorts; either may be sent by post for 1*d*.

Catalogue des Plantes du Jardin de M. De Kwilka, situé à Osnowa aux Environs de Kharcow. — One of the most extensive private collections of house plants in Russia, amounting to about 1000 species.

Traité de la Composition et de l'Ornement des Jardins. 2 vols. oblong 4to. This will be reviewed in an early Number.

De la Loi du Contraste simultané des Couleurs, &c. On the Law of the simultaneous Contrast of Colours, and its Applications. By M. E. Chevreul, Member of the Institute of France, F.R.S. of London, &c. 1 vol. 8vo, pp. 735, and 1 4to vol. of coloured plates. Paris, 1839.

This is a very remarkable work, containing much original matter, applied directly to the disposition of flowers in flower-gardens and shrubberies, and to the mixture of trees and shrubs in ornamental plantations. We intend to review it more at length, as soon as we have leisure; in the meantime we can strongly recommend it to all our readers of taste who understand French.

Report of the Society for obtaining free Admission to the National Monuments. Pamph. 8vo, pp. 8. London, 1840.

Twenty-five public institutions are enumerated in different parts of Great Britain and Ireland, to which, chiefly through the exertions of this Society, the public are admitted free of expense on certain days, and under certain conditions. "The benefit conferred on all institutions for the promotion of literature and science, by the legislature exempting their premises from the assessment of taxes to the queen, is an important feature in the history of our civilisation, and it is hoped, that it will be made complete, by a similar exemption from parochial rates, as it is evident that any tax on popular knowledge must be injurious both to the funds and moral condition of the people."

Government has cancelled the practice of taking fees for the exhibition of the regalia of Scotland, and the Duke of Hamilton has ordered that no demand shall be made for seeing the Palace of Holyrood House. Since the regalia were free, 36,900 persons have visited them in the course of fourteen months. The public are under great obligations to Mr. Hume, the chairman of the committee of this Society, and to George Foggo, Esq., the honorary secretary.

Histoire des Insectes nuisibles à la Vigne, et particulièrement de la Pyrale, &c. By M. Victor Audouin.

This work will develop one of the most ingenious and beautiful applications of science that ever was made, and one that will save millions of francs annually to France. It is under the especial patronage of the government, who have subscribed for a sufficient number of copies to send to all the departments where the vine is cultivated. The prospectus contains the contents of all the chapters into which the work is divided: it will be in 4to, with an atlas of 23 coloured plates, in 5 or 6 livraisons at 10 francs each; and, after publication, the price will be raised to 12 francs. A slight notice of Professor Audouin's discoveries will be found in p. 553.

Bibliothèque Huzard. Pamph. 8vo, pp. 16.

Notice Biographique sur J. B. Huzard. Pamph. 8vo.

The late M. Huzard was an eminent veterinary surgeon, and a great lover of books. He was born in 1755, and died in 1838, leaving behind him the best library on veterinary surgery ever collected in any country. Some expectations are entertained that it may be purchased by the French government; but, in the meantime, it is open to the governments or societies of other countries. We have directed the attention to it, both of the English Agricultural Society and the Highland Society of Scotland.

MISCELLANEOUS INTELLIGENCE.

ART. I. *General Notices.*

WOODEN Pavement for Streets. — Of various modes of paving with wood tried in London, we believe that of De Lisle to be the best. The chief advantage of this plan consists in the system of doweling employed, which, combined with the figures of the blocks unites the whole in one mass so effectually that it is prevented from subsiding unequally, or having the smoothness of the surface deranged until the wood itself is worn out. Neither is this plan so apt to cause horses to slip as some other modes, from the circumstance of the blocks being cut or grooved on the face, and so laid that the diagonal of the square of the surface of the block is always in the direction of the street. We submit these hints to our readers, because we think that when wooden pavement comes to be better understood, it will be adopted in the kitchen and stable courts of various country mansions, where the noise of the carts of tradesmen and others is felt to be offensive to the family. That the courts of honour of all the royal palaces of France will soon have this pavement substituted for the clumsy noisy stone pavements with which they are now covered, we cannot have a doubt. The only thing to be wondered at is, that, with the example of the courts of some hotels and palaces in Vienna, wooden pavement was not adopted in Paris twenty years ago. — *Cond.*

Model Farms, which for many years have been adopted in France, Germany, and even Russia, are now beginning to be formed in Britain. One is commenced by Mr. Morton, on the estate of Lord Ducie, in the Vale of Gloucester; one is in progress in Yorkshire, for the Yorkshire Agricultural Society; one is contemplated in Kent; one has been formed in Dingwall, by Sir F. Mackenzie, Bart., and there is one or more in Ireland. It seems to us equally desirable that an Agricultural Society should have a farm, as that a Horticultural Society should have a garden; and we therefore trust that the English Agricultural Society will soon have an experimental farm worthy of that powerful and respectable body, in the vicinity of the metropolis. — *Cond.*

Approach Roads, consisting of a layer of bitumen spread over a layer of macadamised stone, cost, in the neighbourhood of Paris, 4 francs the square metre, and garden walks which carriages are not to go over may be formed at 3½ francs per metre. Footpaths along public roads, bordered with a kerb of sandstone, cost no more than 3½ francs per metre.

A Layer of Bitumen inserted in a wall, above the foundations, will prevent moisture from ascending from the soil, as effectually as a course of brickwork in Roman cement. Bitumen also preserves wood at a cheaper rate than paint. (*Daly's Revue générale de l'Architecture*, p. 161.)

Clegg and Samuda's Atmospheric Railway is an invention that promises to be as great an advance upon the railways already in use, as these are upon common roads; but we cannot step out of our way to go into details. While observing the pumping of the engine in exhausting the air, we began to reflect as to whether the power of exhausting and compressing air could not be applied in some manner or other to the culture of the soil. If a regular stratum of broken stone were laid under a level space of two or three acres, and a system of cast-iron pipes pierced with holes throughout were laid in this stratum, and communicating with an air-pump, then, in spring, when the temperature of the atmosphere was considerably above that of the soil, which it often is in warm days in March and April, the soil might be heated to the same temperature as the atmosphere; either by working the pump as an exhauster, by which the heated atmosphere would be sucked down through the soil, so as to warm it and the stratum of stones; or by forcing it down the pipes into it, and up through it, so as to effect the same object. Whether such a system could be made to pay or not, is another matter; but we think in the neighbourhood of such a metropolis as London, an acre or two covered with grass, laid out as a public garden, and heated in this manner, might possibly answer. — *Cond.*

ART. II. *Foreign Notices.*

RUSSIA.

GARDENING in Moscow. — M. Holst, seedsman in Moscow, has lately been some weeks in this country establishing correspondents and collecting information. M. Holst is well acquainted with the gardens and nurseries about London, having been three years in the Hammersmith Nursery immediately after the peace, and having, about 1818, been one of the founders of the Southampton Nursery, with one of Mr. Kennedy's sons, now settled in New York. M. Holst is agent for the Moscow Agricultural Society, and the Moscow Horticultural Society; and, being a native of Riga, where he was brought up and educated as a gardener, he is well acquainted with the progress which has been made throughout European Russia. This progress is indeed wonderful. M. Holst's collection of seeds, according to his *Catalogue*, is as extensive as that of any London seedsman; and he has ordered all the principal implements sold by Messrs. Drummond of Stirling, and many of the best English works on gardening and agriculture, including our *Arboretum*, and the great work on cattle by Professor Low. The gardens about Moscow, he says, are as gay as those about London in the summer season. — *Cond.*

NORTH AMERICA.

The largest Purple Beech and Cedar of Lebanon, in the western hemisphere, are growing in the grounds of Thomas Ash, Esq., West Chester County, New York. The grounds had formerly been occupied as a nursery, I believe the original of all the American nurseries. These specimens were, as far as I can learn, among the first of their sorts which were introduced into this country; and they now serve, with other exotics and splendid native species, to render the residence of Mr. Ash one of the most superbly wooded places which has come under my observation on this side of the Atlantic.

Fagus sylvatica purpurea: height 56 ft.; circumference of the trunk, 3 ft. from the ground, 6 ft.; circumference of the head, 12 ft. from the ground, 108 ft. This is a splendid specimen, with a most symmetrically formed semi-elliptical top, and I exceedingly regret that I am not a sufficient draughtsman to send you a correct drawing of it.

Cedrus Libani: height 53 ft.; circumference of the trunk, 3 ft. from the ground, 6 ft.; circumference of the head, 12 ft. from the ground, 90 ft.

As far as I can learn, these trees have been planted about sixty years, but on this point I am not able to obtain sufficiently correct data. — *Alexander Gordon. New York, June 21. 1840.*

Architecture and Gardening have been making rapid progress in New York for several years past, but we have lately observed in the books and engravings received from that country an extraordinary advance in architectural taste. This we believe to be partly owing to the necessity of rebuilding a number of new houses and some churches, in consequence of the great fire a few years ago. We have before us an engraving of New Trinity Church, New York, by Mr. Upjohn, architect, which, for correctness of style, and elegance of design, may vie with some of those of Barry or Blore, for example, at Stratford le Bow and Brighton. The length of New Trinity Church, New York, is 183 ft. 5 in., and the height of the spire 264 ft. It is built of brown stone close-grained, and very highly finished. — *Cond.*

ART. III. *Domestic Notices.*

ENGLAND.

AN additional Park in London. — A meeting is about to be held in the city, for the purpose of founding a royal park within the Tower Hamlets. The institution of such a park, to secure fresh air and a wholesome promenade in the middle of a dense population, cannot but be advantageous to the public

health. The object is supported by some of the most respectable residents in the metropolis. (*Times*.)

An Addition to the Regent's Park is said to be contemplated by the Woods and Forests, which will carry that scene of fresh air and recreation as far as Highgate; and probably some future Earl of Mansfield will join to it the grounds at Caen Wood, decidedly the most beautiful of their kind in the neighbourhood of the metropolis. Hyde Park, we hope, will one day be united to the park of Lord Holland, by the purchase by the government of a narrow strip of ground over the highest part of Camden Hill, so as to join Holland Park with what is now the kitchen-garden of Kensington Palace. The grand entrance into this united Park should be by a magnificent gateway at the end of Pall Mall. — *Cond.*

Public Park at Liverpool. — We have heard it stated that there is a wealthy and truly patriotic gentleman of Liverpool, who is so peculiarly favourable to the formation of at least *one* park, for the health and recreation of our "good old town," that he has expressed a desire, should he find a suitable site, to lay out a sum of 50,000*l.* in the purchase and laying out of the ground, and to dedicate the same gratuitously to the use of the public for ever. The statement of our informant was derived from a gentleman of the first respectability, who, we believe, heard it either from the individual himself or some intimate friend. We sincerely hope that the statement may be verified. Meantime, as so munificent a donation by one individual is so rare in this too mercenary age, as naturally to suggest the possibility of a mistake having arisen; all we can say is, that, if it be the fact, the gentleman alluded to, should he nobly come forward, will earn for himself while living an enviable reputation amongst his contemporary fellow-subjects, and when he has gone to "that bourne from whence no traveller returns," his name, linked with his benevolence, will be cherished with feelings of gratitude and respect for ages to come. (*Liverpool Standard*.)

The Leeds Zoological and Botanical Gardens were opened in June. The Society has expended between 10,000*l.* and 11,000*l.* on the purchase, planting, and laying out of the ground, and on the erection of walls and buildings. The site is most eligible, being in a slight hollow betwixt rising ground on the east and west, sheltered on the north by a hill, and gently sloping down towards the south. Its direction from Leeds is such that it will scarcely ever be reached by the smoke. (*Newsp.*)

Kew Gardens. — Various rumours are afloat as to changes which are about to take place in the arrangement and management of the Royal Botanic Gardens at Kew, but we shall only mention one of them, having heard it from respectable quarters. Sir W. J. Hooker, it is said, has offered his services without salary, provided he has a house rent free sufficiently large for containing his extensive herbarium. — *Cond.*

Victoria regia Lindl. — Living plants of this vegetable prodigy have reached Demerara in safety, and may soon be expected in England. That they will prove as capable of cultivation as other tropical Nymphæaceæ cannot be doubted. (*Bot. Reg. Chron.*, August, 1840.)

A transplanted Mulberry Tree, which remained a Year dormant. — In carrying out some improvements at Lime Grove, Putney, it was deemed necessary to remove a mulberry tree of about forty years' growth, which, standing among other trees, was somewhat stunted, although a tolerably handsome tree of about 18 ft. high, with a head in proportion. Being unwilling to destroy it, considerable pains were taken to lift it with its roots and fibres with the least possible injury, which was effected with corresponding success. The tree was carefully removed, and planted in an open part of the garden, in the autumn of 1838, and I had but little doubt of having succeeded in its preservation. In the spring and summer of 1839 I frequently visited it, but with repeated disappointment in seeing no indications of life, otherwise than that the wood seemed to preserve its vitality. The autumn succeeded, and closed, still leaving the tree in a leafless state. I then concluded that all was over, but still perceiving life in the wood, it was left to remain over winter. In the

beginning of June in the present year, the tree began to push all the way up its main stem, and from several of its larger lateral branches; and, being now pruned in, it promises fair to make in the course of time a handsome tree. — *T. Rutger. Lime Grove, Putney, July, 1840.*

The Bokhara Clover (*Melilotus arborea*) at Oxborough, near Stokeferry, Norfolk, in the garden of Mr. Johnson, is nearly 11 ft. high, and bearing abundance of seeds. Mr. Johnson is so much pleased with this plant, that he means to lay down a small field of it, and treat it like lucern. The seed ripens freely. — *Samuel Taylor. Stokeferry, August 31. 1840.*

SCOTLAND.

Thirlestaine Castle, East Lothian. — The Earl of Lauderdale is making splendid improvements in Thirlestaine Castle; as many as forty masons are at present employed on the garden wall, which, when finished, we are told, will be the finest in Scotland. (*Scotsman.*)

The Earl of Stair is making extensive improvements at the ancient family residences in Wigtonshire, among which may be included the restoration, in the style of Le Nôtre, of the terrace and other architectural gardens, which have been in a state of comparative neglect for nearly half a century. (*Ibid.*)

Gladiolus cardinalis, at Hafton Gardens, the seat of James Hunter, Esq., in Argyllshire, measures 23 ft. in circumference, and exhibits upwards of 100 stems, terminating in spikes of its rich scarlet flowers. This plant, in common with various others at Hafton, says much for the mildness of the climate, and does great credit to the skill and care of the head gardener, Mr. M'Dermid. (*Glasgow Courier, Aug. 8.*)

A Weeping common Oak (*Quercus pedunculata pëndula*) was found in a bed of seedlings sown at Ochertyre in 1825. It was planted on the lawn at Ochertyre House, and is now (1840) 33 ft. high, with regularly drooping branches, which, after they touch the ground, run along it for some distance. Plants of it have been propagated by grafting on stems 5 or 6 feet high, which form beautiful weeping trees. — *Patrick Robertson. Petworth Gardens, Sussex, Aug. 16. 1840.*

IRELAND.

The Belfast Botanic Garden. — In p. 363. we expressed a wish to see the design for the range of plant-houses erecting in this garden, and one has kindly been brought to us by Mr. Ferguson, the curator, now (Sept. 3.) in London. It comes nearer, in general appearance, to the range erected in the Sheffield Gardens, than any other which we recollect, but it is much handsomer. We have not seen ground plans or sections, but these are promised, and when we receive them we shall speak of the whole more in detail. We are happy to have confirmed, by Mr. Ferguson, the favourable accounts which we have heard from various persons, of the prosperity of the garden, and of the extensive source of recreation and enjoyment which it affords to the subscribers and the inhabitants of Belfast generally. The climate of Belfast is so mild, that the common broad-leaved myrtle is as hardy there as the laurustinus is about London. In the winter of 1837–8, when the thermometer about London was 10° below zero, it never fell lower than 14° at Belfast. It is easy to conceive, therefore, that many of the Australian, and especially the Van Diemen's Land, shrubs attain here a degree of vigorous growth never seen in England. — *Cond.*

National Education in Ireland, according to the *Sixth Report* of the Commissioners, is making steady progress, notwithstanding much opposition. The increase of the number of schools, in the course of the year 1839, has been 197, and of scholars 23,736! The Irish people have a much greater aptitude for education than the English, and, if the latter do not soon enjoy the benefits of a national system which shall be applied to all, the Irish, as the Scotch did formerly, will inundate the country with skill as well as strength. (*Morn. Chron., Sept. 10.*)

ART. IV. *Retrospective Criticism.*

PINSA'PO.—A note by Mr. D. Beaton, in p. 277., states “that the Pine of Cephalonia belongs to the section *Picea*, and the *Pinsàpo* to that of *Abies*.” I cannot speak as to the first, not having seen it as yet living, and only knowing it from the 5 or 6 seeds which you were so kind as to send me, and which did not germinate, as you foresaw. Judging by these seeds, as well as by the description and the figure that you have given in the *Arboretum Britannicum*, it appears to me that this tree belongs to the *Picea*.

As to the *Pinsàpo* I can speak more positively. I have plants 3 years and 2 years old; and, besides, I have had in my possession several packages of seeds mixed with their scales. In short, I have a branch with cones, or the remains of cones, on it, they having partly fallen to pieces, although they were gathered before they were quite ripe. The leaves on this branch, and on the young plants, are those of *Abies*, and not of *Picea*; those on the full-grown branch resemble more than any other the *Abies álba* of America (our *sapinette blanche*): I suppose Mr. Beaton has founded his opinion on their appearance. But now the cones are large, upright, their scales are caducous; in short, they, as well as the scales and the seeds, have such a resemblance to those of the silver fir, that it is almost impossible to distinguish them. Now, as it is from the cones that the character of the two sections is principally formed, we must conclude that the *Pinsàpo* is a true *Picea*. Besides, the minute description that M. Boissier has given cannot leave any doubt in this respect. — *Vilmorin. Paris, July, 1840.*

Anomalous Productions of Hybrids. — The paper in p. 289., by the Hon. and Rev. W. Herbert, “On the singular Origin of the Purple Laburnum,” induced me to go carefully over my budded roses with my gardener, and I find between 20 and 30 in the state that gentleman describes as likely to produce hybrid plants by a shorter way than impregnated flowers. The buds are quite dead, but the wood that surrounds them is as green as the day they were put in, in some instances; and in all, my gardener assures me, the wood is alive: these were budded, some in 1838, some in 1839. I have now carefully masked them with bast, to await what may be the result. But I fear I have lost a good opportunity of verifying the truth of this new hypothesis. Thus, being very anxious to obtain flowers of the double yellow Provence rose, I had a branch of Brown's superb budded with it, as I imagined, the whole way up. In 1839 a most vigorous shoot of it was produced, but in the storms of wind and rain of last summer it was blown off; the buds beneath shot, but the wood not being that of the yellow rose, and producing a flower of no beauty, I concluded the man who budded it had made a mistake, and the branch being old and unsightly I cut it off, not having then seen Mr. Herbert's paper. I hope, however, with the prospect of so many in the state I have described, I may have an opportunity of sending you an account of the result. — *Surreyensis. August 17. 1840.*

ART. V. *Queries and Answers.*

THE Curl in the Leaves of Vines. — Can you, or any of your readers, inform me as to the probable cause of the vine leaves assuming a curled appearance, though apparently in a vigorous growing state. I have some vines in a small vinery that are very much curled, while others by their side are not in the least. My opinion is, that it must proceed from an injury to the roots, as there are several green-house plants in the border. If you could, through the medium of your valuable Magazine, inform me as to the cause, you would very much oblige — *A Subscriber. Knightsbridge, July 19.*

THE
GARDENER'S MAGAZINE,
 NOVEMBER, 1840.

ORIGINAL COMMUNICATIONS.

ART. I. *Notes on some Country Seats and Gardens in Lincolnshire, Derbyshire, Staffordshire, Warwickshire, Middlesex, Surrey, Kent, and Hertfordshire, from May to October, 1840.* By the CONDUCTOR.

HUNGERTON HALL (May 20. 22), the present residence of Gregory Gregory, Esq., is a quiet rural abode in an elevated healthy situation. The house is well arranged, and exceedingly comfortable, and the library contains an admirable collection of books on architecture and ancient gardening, more especially foreign works on these subjects. We noticed the following:—

- | | |
|---|--|
| Architecture d'Androuet du Circeau. Paris, 1561. | Pffefel's Views in Vienna. Augsburg, 1724." |
| Fries's Ornaments. 1563. No place. | Théâtre de Piemont. A' La Haye, 1725. |
| Dicterlin's Architecture. 1598. No place. | Maisons de Plaisance de Milan. Milan, 1727. |
| Trésor des Parterres, par Loris. Geneva, 1629. | Butken's Trophées de Brabant. Bruxelles, 1727. |
| Arts du Moyen Age, par Du Sommerard. Paris, 1635. | Théâtre sacré de Brabant. A' la Haye, 1729. |
| Traité du Jardinage, par Boïceau Paris, 1638. | Rademaker's Netherland Cabinet. Amsterdam, 1732. |
| Sanderi Flandria illustrata. Cologne, 1641. | Views of the principal Bridges of Europe, by Schramm. Leipsic, 1735. |
| Meriani, Topographia. 1645. No place. | Traité du Jardinage, par Argenville, A' la Haye, 1739. |
| Œuvres de Silvestre. Paris, 1650. | Works of Piranesi. Paris, 1743. |
| Théâtre des Plans du Jardinage, par Sercy. Paris, 1652. | Works of Vasi, Roma Moderna ed Antica. Roma, 1747. |
| Œuvres de Perette. Paris, 1652. | Tirion's Netherland's Cabinet. Amsterdam, 1749. |
| Loggan's Oxonia Illustrata. Oxford, 1673. | Architecture de Le Pautre. Paris, 1751. |
| Loggan's Cantabrigia illustrata. Cambridge, 1688. | Pffefel, Vues de Mayence, de Salzburg, d'Augsburg. Augsburg, 1751. |
| Suecia hodierna et antiqua. 1691. No place. | Œuvres de Marot. Paris, 1751. |
| Neue Stedebock von Italien, par Blanc. Amsterdam, 1705. | Œuvres de Blondel. Paris, 1752. |
| Le Roi, Castella de Brabant. Amsterdam, 1705. | Rigaud's Views of the Palaces of France. Paris, 1752. |
| Théâtre de la Grande Bretagne, par Kipp, London, 1708. | Ridinger's great work on the Chase in Germany, in all its diversities. Augsburg, 1760. |
| Van Nidek's Views in Holland. Amsterdam, 1709. | Cavillers, Œuvres de. Paris, 1772. |
| Salzbach, Architecture Civile. Augsburg, 1711. | Le Rouge, "Details de nouveaux Jardins." Paris, 1776. |
| Works of Pozzo. Roma, 1717. | |

Coup-d'œil sur Belœil, par le Prince de Ligne. Belœil, 1786.

Millin's Antiquités Nationales. Paris, 1790.

Vues d'Amsterdam. Amsterdam, 1805.

Voyages dans l'ancienne France, par Taylor, Nodin, &c. Paris, 1815.

Laborde, Monumens de la France. Paris, 1816.

Falda, Fontane di Roma. Roma, no date.

Works of Visentini. No date.

Visser's Views in Holland. Amsterdam, no date.

Ornemens de Berain. Paris, no date.

Fontaines, par Le Brun. No date.

Teatro di Venezia. Venezia, No date.

Oppenort's Architecture. No date.

Plafonds de la Galerie de Florence. No date.

Vitruvien Denmark. No date or place.

Architecture des Jardins, par Filet. No date or place.

Besides a great number of county histories; and a great variety of old works on chivalry, heraldry, fêtes, and processions.

In the kitchen-garden, and also in a large garden, which may be called a nursery, hardy and house plants of various kinds are bringing forward for the terrace gardens and conservatories now forming at Harlaxton new Manor; and for stocking the indigenous woods there. There is also an excellent collection of grapes, and the manner in which these are cultivated by Mr. Wade the gardener, particularly in one house, having a pit for pines or other plants, is new, and well deserving of imitation.

The back wall of this house is flued, and the space allotted for the back alley is given to the vines as a border for their roots. If the pine-pit walls had been thrown upon arches, a greater increase of space for the extension of their roots would of course have been available. The circumstance of root and branch being thus out of the reach of the atmospheric changes belonging to the early months of the year is very important to early forcing, and the back wall having a flue running very contiguous to these roots places the climate, and the period of commencing their growth, completely in the power of the cultivator. It is only in such a situation that the delicate and perfumed sorts, such as Purple White Constantia and the Grizzly Frontignan, perfect and mature their growth and ripen their fruit.

The mode adopted at the Royal Gardens at Kensington, as detailed in some of the early volumes of this Magazine, of constructing the top sashes of the roof of a size exactly to fill up the space and height from the back pit wall up to the roof of the house, is a very great and ingenious improvement; for by this means the back wall crop can be made to have a winter, or rather state of rest, and the main body of the house still kept for its usual purposes; the back alley being alone detached from it, and exposed during the latest summer months to the open air.

This forms the arrangement for the first crop of grapes. The second, or intermediate, crop is obtained by allotting the space for the front alley as a border for the vines, so that the roots are here again never submitted to atmospheric changes; but, as there is no flue which can be said to be sufficiently near to this border to lend to it an increased state of heat, it has been found that the afore-named tender sorts, with a very luxuriant growth, and great vigour and size of bunch, will never ripen on this border, although they do so very successfully in the same house on the back wall, where there is a flue worked with a very gentle fire. The Hamburg, Sweetwater, and Muscat have ripened in that situation. These vines are trained to the rafters.

The third crop is derived from the border out of doors, in the usual way, and the vines are trained to the rafters. The succession is obtained by wintering them along the front uprights of the house, and placing them between two walls or screens of glass. They are, by this glass chamber, if we may so call it, never exposed to the entire rigour of the winter, and are introduced into the house to their rafters at the option of the gardener, or as late as their tendency to break their buds admits of.

This arrangement utilises as much as possible the area both of glass and ground, does not destroy the facilities of circulation, or of cultivating pines

in the pit, admits of the cultivation of a greater variety of the most esteemed sorts, and obtains an immense power of succession.

The following are the kinds of grapes grown :— Purple Constantia, White Constantia, Grizzly Frontignan, Muscat of Alexandria, Stillwell's Sweetwater, West's St. Peter, Black Damascus, Black Tripoli, Black Hamburg, White Portugal, Syrian.

In the plant stoves, palms of various kinds, dracænas, musas, bamboos, and various fragrant-flowered climbers, are bringing forward in pots and tubs for the conservatory at the new Manor House.

An experiment has been tried in one of these houses by reversing the position of the sash-bar, so that the rabbet is on the under side, and the insertion of the panes is made from that side instead of from the outside, as in the usual manner. The advantage of this mode is, that the putty is not exposed to the weather, but sufficient time has not yet elapsed to determine its value. The difficulty that appears to be most likely to establish itself respecting the reverse glazing is, that of the execution of it, and the repair, supposing that the lights are not movable but fixed. In the first instance, it is feared that the pane cannot be made to retain its position, but will fall, or at least move slightly from its place, from its own weight, before the putty is sufficiently set or hardened to retain it. In repairing, the workman is not so conveniently placed ; he is like a painter of ceilings, and ought to be laid on his back. Probably Mr. Paxton's mode of having a groove in the sash-bar, as hereinafter described, may ultimately be found preferable.

Belton, near Grantham ; Earl Brownlow. — May 21. We passed to this place from Harlaxton, through Grantham, and a very miserable village, which we could not help wishing had belonged to Mr. Gregory. The wretched hovels exhibited not only a want of taste in their exteriors and surrounding gardens, but even a want of repair and the appearance of common comforts. Belton we have always understood to be one of the best kept places in England, and we certainly found it so, though the family had been absent some months, and were not expected till July. We entered by the kitchen-garden, which was originally planned by, and built under the direction of, Mr. Webb. The pine stoves and vineries are wide, with a fixed roof formed by bars without rafters, resting on a horizontal iron rail, supported by iron pillars, rising from the middle of the tan pits. The only inconvenience that the gardener, Mr. Ingram, finds from these pillars, is, that he is in danger of breaking the long stiff shoots of the vines, when he removes them from the rafters to lay them down to rest on the top of the front wall, in Mr. Strutt's manner. The grounds have few natural inequalities ; but the river Witham runs through them, and this feature has been made the most of, especially near the house, which is a fine old French mansion, with stately avenues. Among the old trees are some good specimens, especially of elm and Scotch pine. There is a rustic bridge leading over a piece of water to what may be called a fancy cottage, which is covered over with rustic trelliswork for climbers, and these climbers are planted in rustic boxes, which project from the outside of the parapet of the bridge. The idea is comparatively new, and the effect good. In the church, the tower of which forms a fine object from the walk in the pleasure-grounds which leads to it, are some fine sculptural monuments of the Brownlow family, and in the churchyard are several to their servants ; kindness and consideration to them being apparently hereditary in the family. One tombstone is to the memory of a gardener, who had been 54 years in the family, and died in 1710. The place has two defects which might easily be remedied. The first is, that there is no master walk so conducted as to display the main features of the place ; and the second, that the kitchen-garden cannot be entered without crossing a public road, and also, if we are not mistaken, a farm road. A tunnel or tunnels would at once remove the latter objection, and facilitate the removal of the former.

The home farm-offices are very complete ; we entered the poultry-house, which is a square room, well lighted, and heated by an open fireplace. There is a range

round the room of coops for hens with chickens; above it, one for laying-hens; and above that, one for such as are hatching. On each side a hen stair leads to the roosting-place, which is above the ceiling, so that nothing can ever drop on the floor. The village here is being remodeled in the Gothic style in good taste, and is already a most gratifying and conspicuous ornament to the public road. Would that His Lordship might extend this admirable improvement to all the cottages on the estate! By way of expression of purpose, the smithy has a large horseshoe sculptured on the gable, which projects over the entrance. The inn and public houses have carved stone figures for their signs; the beautiful schoolhouse has a quotation, and the village shop has a riband label of stone (too broad, and not very tastefully displayed) over the broad window for displaying the goods. In the flower-garden we observed a curious hybrid between a Brompton stock and a wallflower, which appeared to be producing seed; and which, at all events, we trust Mr. Ingram has propagated by cuttings.

Chatsworth.—*May 23.* When we last visited this place in May, 1839 (see our preceding vol. p. 450.), the grand conservatory was just beginning to be glazed, and at present the glazing is almost completed. The panes are 3 ft. 9 in. in length, and 6 in. in width, and the work was performed by Mr.

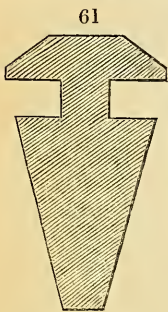

61

Drake, glazier, Edgeware Road, London, at the rate of 16*d.* per square foot. The sash-bars are of deal, cut out by machinery impelled by steam. *Fig. 61.* is a section of the bar of the full size; and *fig. 62.* are specimens of the glass of the full thickness, showing at *b* the thinnest glass, and at *a* the very thickest that is used in the conservatory; or, in other words, showing the variation of thickness that takes place in this description of glass. The roof, as most of our readers know, is in the ridge-and-furrow manner, and the quantity of sash-bar used in forming the sides of the ridges, exceeds 40 miles in length. The hot-water heating-apparatus is already put up by Messrs. Walker

62



of Manchester; there are 8 boilers, and the length of pipe, which is 4 in. in diameter within, is about 7 miles. There is such a thorough command of water on the adjoining rising grounds, that it would be easy to form a system of pipes for throwing down a shower over the whole interior of the house, in Messrs. Loddiges's manner; and the water for this purpose might be heated by passing the pipes containing it through a mile or two of the heating pipes. This has already been done with the pipes which supply water for the ordinary watering of the house. The progress of fitting up the interior is going on steadily, and will be completed, and many of the trees planted, in the course of the autumn. The trees in the arboretum are in a most thriving state; and planting on little hills of prepared soil, keeping these hills afterwards clear of weeds and covered with short grass, has done as much here for the growth of the plants as it has done at Elvaston Castle and the Derby Arboretum. Some of the rarer species of *Pinus Abies* and *Picea* have made vigorous shoots, and will soon become fine trees. *Acer palmatum*, which was killed every where about London, by the winter of 1837-8, except in Mr. Knight's nursery, has never had any protection here, and is now 3 ft. high in the open arboretum. The nomenclature of the arboretum is unavoidably in a state of confusion; because, Mr. Paxton's object being to collect as many species as he could, wherever he found a different name he ordered a plant, and planted it with the name which he received, with a view to future comparison and correction. In another year, by sending one of his young men to the Derby Arboretum, he will be able to adjust the nomenclature at Chatsworth to that of the Arboretum at Derby, which we think it will not be denied is at present the most correctly named collection of trees and shrubs in England. If it is not so, then we have spent ten years of our life, and expended in cash or credit above 10,000*l.*, in vain.

The conservative wall which separates the lawn from the park on the north is a most delightful scene, and confirms the observations of our correspondent in p. 23., "that a conservative wall is a very superior source of enjoyment to either a green-house or a conservatory." It is 340 ft. in length, and the direction being up a sloping surface, it is divided into panels about 27 ft. in length, and about 18 ft. high, rising above one another, with stone piers between each. The wall is flued and covered with a wooden trellis. It has a coping which projects about 1 ft. in front, with a rod under it on which the rings of curtains run. Piers are built every 27 ft. apart, which determine the length of the curtain rods; and half the curtain draws up against each pier, as in the case of a common window. The curtains are of stout hempen cloth, striped with blue; and in order to provide for the contraction and expansion, and also to keep the curtains tight when let down, the lower edge of the curtain is furnished with rings, which are put over hooks fixed on the edge of a board which lies flat on the border at the distance of $13\frac{1}{2}$ in. from the wall. The other edge of this board, which is $11\frac{1}{2}$ in. wide, is hinged to a rail $4\frac{1}{2}$ in. broad, which is made fast to stakes driven into the ground, and sawn off level with the surface. In consequence of this arrangement, when wet weather contracts the curtain, instead of shrinking up, and exposing a part of the wall to the weather, it merely lifts up the inner edge of the board, which sinks down again to its place with the return of dry weather. The edges of the curtain next the piers are made fast to slips of wood fixed to the wall, and the edges where the curtains join in the middle overlap each other, as in common window or bed curtains. Nothing is planted against the piers but dahlias during summer, and thus, by leaving these naked, they preserve the architectural dignity of the wall by contrast with the covered parts. With a view to this end, and also to the effect of the flowers on the plants in the panels, even the dahlias, in our opinion, would be better omitted.

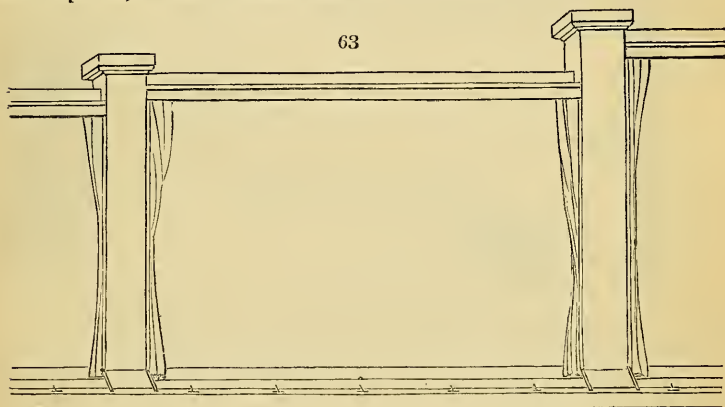

Fig. 63. is an elevation of part of the wall showing the piers (the one rising higher than the other, as the wall ascends a sloping surface), and the curtains drawn aside.

Fig. 64. is a ground plan of the same portion of the wall; in which *a* is the dug border, *b* the rising and falling board, *c* fixed boards opposite the piers, *d* a border of turf, *e* a gravel walk 6 ft. wide, and *f* the lawn.

Fig. 65. is a section of the wall, the wooden coping, the curtain, and the rising and falling board.

Fig. 66. is a section of the lower part of the wall, the rising and falling board, and the ground rail to which it is hinged, on a larger scale.

The following list of the plants now growing against this wall has been, at

our request, kindly furnished by Mr. Paxton. They are arranged here according to the natural orders, for the sake of showing the great variety of

64

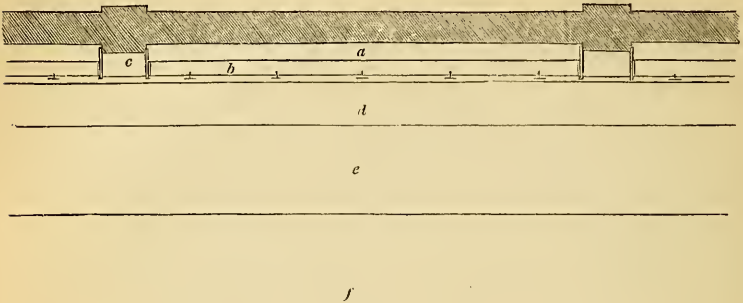

species; but they are planted against the wall in no particular order, except that the more tender sorts, such as orange trees, *Jasminum grandiflorum*, &c., are generally placed together, so that the part of the wall against which they are placed may be heated by itself; whereas, if they were distributed over the whole wall with the hardier sorts, such as *Sophora microphylla*, *Tecoma capreolata*, &c., which require no artificial heat, there would be a considerable loss both of labour and fuel.

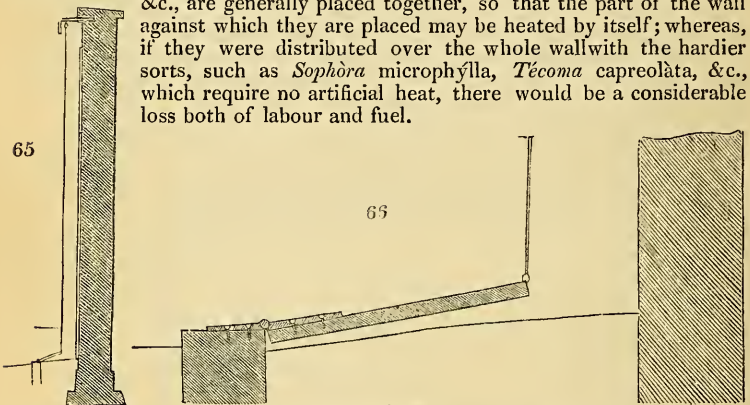

Ranunculææ.

Clématis flórida Sieböldii, planted in 1837, is 9 ft. high, and in another place has reached the top of the wall in a panel over low-growing shrubs. Like other climbers it does not spread much in width. In flower it is singularly ornamental.

Clématis azúrea grandiflora, planted in 1837, is 15½ ft. high, and 2 ft. wide. Splendid when in flower.

Dilleniææ.

Hibbértia volúbilis, planted in 1836, is 10 ft. high, and 2 ft. wide.

Magnoliææ.

Magnòlia grandiflora, planted in 1836, is 4½ ft. high, and 3½ ft. wide.

Winterææ.

Illicium floridànnum, planted in 1838, is 1 ft. high, and 1 ft. wide.

Berberidéæ.

Bérberis ? sp., planted in 1838, is 3 ft. high, and 1 ft. wide.

Polygâlææ.

Polýgala grandiflora, planted in 1837, is 8½ ft. high, and 7 ft. wide.

Pittosporææ.

Billardiæra longiflora, planted in 1837, is 16 ft. high, and 1 ft. wide.
Billardiæra mutabilis has in the same period attained the height of 17 ft., and is 1 ft. wide.
Sóllya heterophýlla, planted in 1837, is 4½ ft. high, and 2½ ft. wide.

Línææ.

Linum trígynum, planted in 1838, is 1½ ft. high, and 1½ ft. wide.

Malvæææ.

Málva ? sp., planted in 1840, is 8 ft. high, and 3 ft. wide.
Málva Creeána, planted in 1839, is 7½ ft. high, and 5 ft. wide.

Aurantiæææ.

Various orange trees, planted in 1836, are from 3 ft. to 9 ft. high; and the standard have the lower part of the wall covered with *Maurándya Barclayána* and *Tropæolum peregrinum*.

Tropæòlææ.

Tropæolum peregrinum grows to the top of the wall every season.

Rutæææ.

Corræa speciosa, planted in 1837, is 5½ ft. high, and 1½ ft. wide.
Corræa álba, planted in 1840, is 3½ ft. high, and 10 in. wide.

Anacardiæææ.

Schinus Mólle. A very large plant of this fine evergreen has lately been killed to the ground, but is now springing up again.

Leguminòsææ.

Acácia lophántha, planted in 1837, is 7½ ft. high, and 3 ft. wide.
Ac. melanóxylon, planted in 1837, is 16 ft. high, and 3 ft. wide.
Ac. decúrrens, planted in 1837, has attained the height of the wall, and has been several times cut in.
Ac. rutæfòlia, planted in 1840, is 3 ft. high, and 16 in. wide.
Ac. vestita has just been planted.
Brachysèma undulàta, planted in 1837, is 5 ft. high, and 1½ ft. wide.
Bossia scolopéndra, planted in 1840, is 18 ft. high, and 1 ft. wide.
Callístachys lanceolàta, planted in 1840, is 4 ft. high, and 1 ft. wide.
Clíanthus puniceus, planted in 1837, is 11 ft. high, and 10 ft. wide. A splendid specimen.
Davièsia mimosòides, planted in 1840, is 2 ft. high, and 1 ft. wide.
Dorýcnium hirsútum, planted at the same time, is 6 ft. high, and 3 ft. wide.
Eutáxia myrtifòlia, planted in 1837, is 5 ft. high, and 3½ ft. wide.
Edwárdsia grandiflora, planted in 1837, is 2½ ft. high, and 1 ft. wide.
Ed. micropýlla, planted in 1836, is 13 ft. high, and 3½ ft. wide.
Erythrína Crísta-gállí, planted in 1837, is 5 ft. high, and 1½ ft. wide.
Glycine bimaculàta is a small plant.
Kennèdya nígricans, planted in 1837, is 15 ft. high, and 3 ft. wide.
Ken. rubicúnda, planted at the same time, is 16 ft. and 1 ft. wide.
Mimòsa prostràta is mixed with other plants, and climbs to a considerable height.
Swainsonia coronillæfòlia, planted in 1836, is 11 ft. high, and 3 ft. wide.
Wistària Consequàna, a magnificent vigorous-growing specimen, spreads to a great distance over the walls of some stable buildings, which join with the conservative wall, and form its termination at the farther extremity from the house.

Rosæææ.

Cydonia japónica, planted in 1837, is 12 ft. high, and 6½ ft. wide.
Ròsa moschàta, planted in 1837, is 12 ft. high, and 2½ ft. wide.
Ròsa Banksiána, planted at the same time, is 15 ft. high, and 2½ ft. wide.

Photinia serrulata, planted in 1837, is 10 ft. high, and 6 ft. wide.

Calycanthaceæ.

Chimonanthus fragrans, planted in 1838, is 6 ft. high, and 3½ ft. wide.

Granatæcæ.

Punica Granatum, planted in 1837, is 5 ft. high, and 3 ft. wide.

Onagrariæ.

Fuchsia globosa, planted in 1837, is 15½ ft. high, and 11 ft. wide. A magnificent specimen.

F. globosa major, planted in 1837, is 12 ft. high, and 6 ft. wide.

F. conica, planted in 1837, is 8 ft. high, and 5 ft. wide; another specimen, planted in 1836, is 12 ft. high, and 8½ ft. wide.

F. Thomsoni, planted in 1837, is 9 ft. high, and 6 ft. wide.

F. microphylla, planted in 1837, is 16 ft. high, and 2 ft. wide; another specimen is 6 ft. high, and 2½ ft. wide.

F. fulgens, planted in 1840, is 2½ ft. high, and 5 ft. wide.

Philadelphicæ.

Deutzia scabra, planted in 1839, is 5 ft. high, and 2½ ft. wide.

Myrtacæ.

Callistemon semperflorens, planted in 1837, is 15½ ft. high, and 2½ ft. wide.

Eucalyptus ? sp., planted in 1837, has attained the height of the wall, and is 16 ft. wide.

E. globulus and E. resiniferus, planted in 1836, have, like the preceding species, far exceeded the height of the wall, and been cut in the two last years; three other species, the names of which are unknown, have attained the height of 5 ft., 6 ft., and 10 ft.

Leptospermum grandiflorum, planted in 1837, is 6 ft. high, and 3 ft. wide.

L. trinerve, planted in 1837, is 7½ ft. high.

Melaena fulgens, planted in 1837, is 8 ft. high, and 7 ft. wide.

Psidium Cattleyanum, planted in 1837, is 3 ft. high, and 1½ ft. wide.

Myrtus communis. Various plants from 3 ft. to 10 ft. high.

Passifloræ.

Passiflora cærulea has attained the height of the wall, and spread along it, forming a belt 6 ft. wide; another plant is 16 ft. high, and 22 ft. wide.

Pas. Mayana runs along the wall at 5 ft. from the top, to the distance of 9 ft. on each side of the main stem, and the breadth covered is 5 ft. deep.

Grossulariæ.

Ribes speciosum, planted in 1837, is 15 ft. high, and 2 ft. wide.

Cornacæ.

Benthamia fragifera, planted in 1836, is 10 ft. high, and 7½ ft. wide.

Escalloniæ.

Escallonia glandulosa, planted in 1839, is 3 ft. high, and 1½ ft. wide.

Esc. viscosa, planted in 1838, is 9½ ft. high, and 2½ ft. wide.

Caprifoliacæ.

Caprifolium gratum, planted in 1837, is 8 ft. high, and 1 ft. wide.

Cap. etruscum, planted at the same time, is 16 ft. high, and 2 ft. wide.

Ericacæ.

Thibaudia setigera, planted in 1838, is 5½ ft. high.

Vaccinium Sprengelii, planted in 1838, is 2 ft. high, and 1 ft. wide.

Oleineæ.

Ligustrum lucidum, planted in 1838, is 13 ft. high, and 3½ ft. wide.

Jasminæ.

Jasminum umbellatum [?], planted in 1837, is 4½ ft. high, and 3 ft. wide.

Jasminum undulatum, planted in 1840, is 5 ft. high, and 1 ft. wide.

J. grandiflorum, planted in 1837, is 4 ft. high, and 3 ft. wide.

J. sp., planted in 1839, is $4\frac{1}{2}$ ft. high.

Bignoniaceæ.

Bignonia spectabilis, planted in 1837, is $5\frac{1}{2}$ ft. high, and $2\frac{1}{2}$ ft. wide.

B. capreolata, planted at the same time, is 16 ft. high, and $2\frac{1}{2}$ ft. wide.

B. pteridifolia [?], planted in 1837, is 6 ft. high.

B. jasminoides, planted in 1837, is 5 ft. high.

Tecoma sp., planted in 1837, is $9\frac{1}{2}$ ft. high, and $2\frac{1}{2}$ ft. wide.

Calámpelis scaber is planted in several places to fill up blanks.

Cobæaceæ.

Cobæa scandens, planted in 1840, is 10 ft. high.

Boraginæ.

Heliotropium peruvianum, planted in 1840, is 3 ft. high, and $3\frac{1}{2}$ ft. wide.

Solanæ.

Brugmansia sanguinea, planted in 1839, is $8\frac{1}{2}$ ft. high, and $8\frac{1}{2}$ ft. broad.

Scrophulariæ.

Lophospermum scandens, planted in 1837, is $8\frac{1}{2}$ ft. high.

Maurandya Barclayana is planted in several places to fill up blanks.

Pentstemon gentianoides, planted in 1840, is $4\frac{1}{2}$ ft. high, and $3\frac{1}{2}$ ft. wide.

Rhodochiton volubile is planted to fill up blanks.

Calceolaria viscosissima, planted in 1836, is $5\frac{1}{2}$ ft. high, and 2 ft. wide.

Labiatæ.

Salvia chamædrifolia, planted in 1840, is $2\frac{1}{2}$ ft. high, and $1\frac{1}{2}$ ft. wide.

Verbenæ.

Lantana Sellowii, planted in 1839, is $2\frac{1}{2}$ ft. high, and 1 ft. wide.

Plumbaginæ.

Plumbago capensis, planted in 1837, is 11 ft. high, and $2\frac{1}{2}$ ft. wide; another specimen, planted in 1836, is 10 ft. high, and 4 ft. wide. The fine blue of the flowers of this plant produces a charming effect, contrasted with the yellow flowers of most of the Leguminosæ.

Proteæ.

Grevillea acanthifolia, planted in 1840, is $2\frac{3}{4}$ ft. high, and 1 ft. wide.

Hækea florida, planted in 1840, is $2\frac{3}{4}$ ft. high, and 1 ft. wide.

Hækea sp., planted in 1837, is 7 ft. high, and 2 ft. wide.

Aristolochiæ.

Aristolochia glauca, planted in 1837, is 11 ft. high, and $2\frac{1}{2}$ ft. wide.

A. siphon, planted in 1837, is 16 ft. high, and $1\frac{1}{2}$ ft. wide; another specimen, planted in 1838, is 16 ft. high, and 1 ft. wide.

Garryæ.

Garrya elliptica, planted in 1837, is 11 ft. high, and $2\frac{1}{2}$ ft. wide.

Casuaræ.

Casuarina equisetifolia, planted in 1837, is 8 ft. high, and $2\frac{1}{2}$ ft. wide.

C. tenuissima, planted in 1837, is $3\frac{1}{2}$ ft. high, and 6 ft. wide.

C. stricta, planted in 1837, is 9 ft. high, and 6 ft. wide.

Smilacæ.

Ruscus androgynus, planted in 1837, is 3 ft. high, and $1\frac{1}{2}$ ft. wide.

In the lawn at Chatsworth there is a want of artistical finish to the water-works, and of an obvious connexion among them, and with the house. The long straight canal, for example, should be lined with masonry ornamented with piers, some of them crowned by sculptural objects, and connected, in

reality or in appearance, with the terrace walls of the house. The magnificent cascade of steps is admirable, so far as it goes, but its lower termination is poor. The cascade ought, perhaps, to be brought down nearer to the house, and the basin, in which it terminates, ought to be surrounded by a highly architectural margin. At all events, something ought to be done to take away from the scattered, disjointed, and in some cases meagre, appearance of these water-works, which, taken separately, are by far the grandest in Britain.

In the kitchen-garden Mr. Paxton is introducing a new mode of covering glass cases, whether frames, pits, or low houses, during the night. This is simply by having a thatched roof of somewhat larger dimensions than the frame, pit, or house to be covered, resting on side walls, and independent of those which support the glass; the lower edge or base of this roof slides on a railway, which extends at either or at both ends of the house, so as to afford space for the roof to stand on in the day time, or when it is not wanted. The advantages of this mode of covering are, that more heat can be retained than by mats or boards; and that the covering and uncovering can be effected with less labour, and almost instantaneously.

The house on which the experiment is about to be tried is for growing orchidaceous plants, and is being heated by Mr. Penn. It is span-roofed, and stands in the direction of north and south: *fig. 67.* is a section, in which *a* is the glass roof, and *b* the thatched roof. The situation is low, and being on a level with the river, is incapable of drainage beyond a certain depth; in consequence of which, a water-tight cast-iron box, or caisson, is sunk, and in it the furnace and boiler are built. This practice is common in Holland even for dwelling-houses; the lower rooms of which, being often

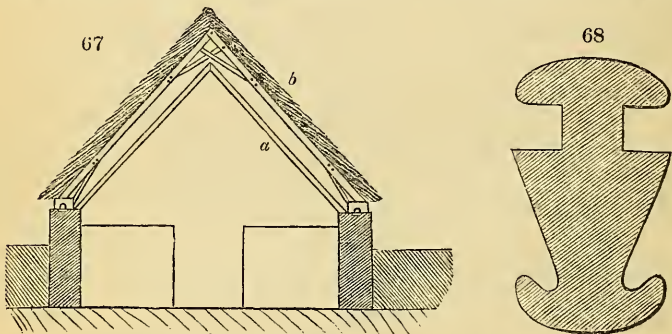

below the level of the adjoining canals, have a thick flooring and thick side walls of masonry, built with cement, which completely exclude water. The sash-bar used in this orchidaceous house has side gutters for collecting the drip, as shown in the section, *fig. 68.*, which is of the full size. The glass is intermediate between the two thicknesses, shown in *fig. 65.* p. 572., and is 6 in. wide, in panes not exceeding 40 in. in length; the cost of which, glazing included, is about 1s. 4d. a square foot.

In Germany and Holland, plant structures with upright glass in front, as in the Botanic Gardens at Munich and Leyden, are covered with great rapidity by letting down rolls of straw mats, as noticed in our vol. for 1830; and where the glass roof slopes, hinged shutters, suspended from the back wall by cords and pulleys, are instantly let down, and as quickly pulled up, as in the Botanic Gardens at Carlsruhe. These modes, however, are not so well adapted for this country, where few houses have opaque roofs and only front glasses; and equally few those elevated projections called bonnet roofs, shown in *fig. 69.*, in which *a* is the point where the shutters are hinged.

Perhaps the operations that we were most gratified with, on our present visit to Chatsworth, were those carrying on in the village of Edensor. The

cottages are being rebuilt, added to, or repaired and ornamented, and their gardens will be enlarged and tastefully laid out and planted. All the houses will be supplied with water from an elevated source, the village being on the side of a hill; and there will be a public play-ground and open shed, and a public drying-ground. Behind the houses are the fields for grazing the cows, of which each cottager has one or more. The school is almost the only

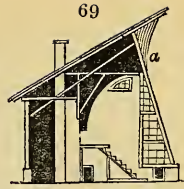

building so far finished as to enable us to judge of its effect, which, we think, will be excellent. We entered several of the cottages, and found them most comfortable and commodious within; all of them had back kitchens, pantries, and dairies for the produce of the cow, with the sleeping-rooms up stairs. We have no doubt, that, when this village is completed according to Mr. Paxton's ideas, His Grace the Duke will be so much pleased with it, as to cause a revision to be made of all the cottages on his extensive estates; and a better mode of doing good, both positively to the occupants, and, by example, to the cottagers of other proprietors, and to cottagers generally, we do not think could be devised.

All that Derbyshire wants, to render it the most beautiful and interesting county in England, is, plantations on the high grounds to improve the climate and beautify the face of the country, and more artistical cottages, farmhouses, and gardens.

Chatsworth to Wootton Lodge, by Chesterfield and Derby. — May 24. To Chesterfield the country is bleak, but the fields are divided by stone walls, and tolerably well cultivated. The railroad from Chesterfield to Derby passes through the most interesting tract of country on the line between Sheffield and London; and the road from Derby, by Ashbourne to Alton Towers, is most romantic.

Wootton Lodge is a remarkably fine old place. The house is a square building, of the time of Elizabeth, imposing from the magnitude of the mass, and from its great height, considering, that it is a dwelling-house, in proportion to its width. It is situated on a prominent rock or hill, surrounded on three sides by a deep ravine, which separates it from higher hills, which are covered with oak woods. The elevation of the house, we repeat, is very imposing, and this arises chiefly from magnitude, and from the height and breadth of the many mullioned windows, and the large spaces of naked wall between them.

The mass of the building is sufficiently large to constitute it grand, and the height, relatively to the breadth, being greater than what is common in buildings of this era, it joins to grandeur a character of elegance, which never can be given in buildings without departing somewhat from the common proportions, and exceeding these to a certain extent in height. The windows at *Wootton Lodge* are grand, and yet elegant, from the same cause by which these impressions are produced by the general mass; that is, they are as broad, if not broader, than usual, and they are decidedly higher than is commonly the case in windows of this style. It may be laid down, then, as a principle, that a building or a window, broader than is usual in proportion to the height, is mean; and, on the contrary, that a house or a window, higher than is usual in proportion to the width, is comparatively elegant.

In *Wootton Lodge*, there are few projections in the way of bays, no towers, very little ornament, scarcely any upper cornice, and the roof, which is of lead and flat, is of course not seen. The chimney shafts are good, though few and simple. Altogether, the exterior of this house deserves the study of the architect, not for its ornaments or details, for these are few, but to find out the cause of the powerful impression which it makes on the mind. We were not within, but from the large windows and the broad space between them in the elevation, it is impossible to doubt, that the interior contains some very magnificent rooms. It is entered through a court of honour, with offices as

wings or lodges to the right and left of the entrance to the court; and beyond these, on the steep sides of the hill, are the terraced gardens and walks among the rocks and aged yew trees which surround the house, except on the entrance side. On a platform facing one of the fronts, there is a curious raised garden, with a canal bordered with masonry, and containing a fountain in the form of a duck, doubtless coeval with the building. Near the kitchen entrance we observed, against the wall, a case of about 4 ft., containing an overshot water-wheel, supplied by a $\frac{1}{2}$ in. pipe of water used for turning the roasting-jack. It is impossible, as it seems to us, not to be charmed with this place.

Alton Towers.—We had only time to take a hasty glance at what may be called the enchanted valley, and to see a new flower-garden recently tastefully designed and most scientifically laid out by Mr. Forsyth, in one of the courts of the Abbey. The valley, in the time of the late Lord Shrewsbury, had a peculiar charm, from the great number of objects, all of an artificial and singular or grotesque character, in so romantic a situation, and from the trees and shrubs being either small, or cut or clipped into artificial shapes.

Whoever recollects this valley, as it was in 1825, so as to be able to compare it in his memory with its present state, must acknowledge that there is a wonderful difference between what it is now and what it was then. Now, the question is, whether this difference is an improvement, or the contrary? Decidedly, in our opinion, it is for the worse. The gardens have lost one character without gaining another. The trees and shrubs have grown too large for the terraces, walks, walls, and buildings; and, being no longer cut or clipped into shape, they seem to have no accordance with the artificial objects. The whole has the appearance of a scene allowed to run wild from neglect, not from age or decay; and this, notwithstanding the highest keeping of the walks, flower-beds, and every thing that depends on the gardener. When a place becomes wild from total neglect, or from age or decay, we become reconciled to it, as the result of inevitable circumstances, as, in short, the fate of all things; but, when we see one part of a scene in the highest style of keeping, and in a particular character, intermingled with a part of a character totally opposite, we are dissatisfied with the discordance of the impression made in our minds from its want of unity. In theory, we have always been an advocate, where the ancient style of gardening is adopted, of subjecting the trees to geometrical forms, as well as the ground; and no circumstance has ever occurred, within our experience, to convince us that we were practically right, equal to the state of the grounds at Alton Towers. We ascribe no fault to any one for this state of things, which has grown up insensibly with the seasons, and which a person living on the spot is not nearly so likely to be impressed with, as an occasional visiter.

The stoves, green-houses, and conservatories were in most beautiful order: in the latter, Mr. Forsyth is introducing borders, of *Lycopodium complanatum* about 6 in. broad along the walks, which have a remarkably good effect, and being the "resemblance" of verges in the open garden, "in some other thing which becomes the image" of them, it may be considered on Q. De Quincy's principle, as truly artistical, and completing the allusion to nature in the open air. These verges are sometimes planted at once in the soil where they are to remain, and at other times on pieces of loam and dung about the length and breadth of a brick, and kept in a glass frame till wanted, when some hundreds of yards of edging can thus be laid down in an hour or two. By means of these bricks, also, repairs can be made momentarily. No edging is better adapted for growing in the shade and in heat. The works connected with the house are going forward under the direction of Mr. Pugin, a most fortunate circumstance for Alton Towers, as far as Gothic architecture is concerned.

Trentham Hall.—*May 25.* The road from Alton Towers, by Cheadle, is at first hilly and romantic, and afterwards rich and varied. The alterations and additions to the house at Trentham are far advanced, and they have had

a magical effect on the place. The effect of the tower at one angle, in forming a centre to the general mass, carrying it off, as artists say, or, in artistic philosophy, communicating an axis of symmetry (see p. 233.), is most satisfactory. The central tower at Alton Towers is too small for the immense pile of buildings that surround it, having been built, no doubt, before it was contemplated to increase them to such an extent; but this at Trentham appears of the proper dimensions, unless, perhaps, it is not sufficiently high. The first or upper flower-garden is laid out in what the French call the English style, with beds of turf, and dug beds edged with box or gravel, and has an excellent effect, the whole forming a raised platform edged with stone. The lower or main garden has the leading walks formed and gravelled, and the slopes turfed; but, not being yet planted, it has rather a naked appearance. We were shown some Portugal laurels, which were training with clean stems and round heads, to imitate the orange trees of the Continent, as at Chatsworth, to be planted along the main walks at regular distances in stone boxes. If the Portugal laurels were budded standard high with the common laurel, the effect would be still more striking, as the light green of the leaves would render the allusion to the orange tree much more complete. Such imitations of orange trees are not uncommon in the neighbourhood of Paris, where the laurel is grafted standard high on the common cherry, which, however, being a deciduous plant, does not form so good a stock for an evergreen as the Portugal laurel would. The common laurel, to a general observer, is so very like the orange, that, some years ago, a foreign ambassador, who was going round the grounds at Clarendon with the gardener, Mr. McIntosh, took the laurel undergrowths there, with which the woods abound, for dwarf orange trees, and expressed his astonishment at seeing the orange thrive so well in England.

For the two side walks at Trentham, we would introduce a border of arcades, cones, or pyramids, of clipped yew, box, or variegated holly. As these, however, are of slow growth, ivy trained on wire framework might be substituted; by which means the arcade might be completed in two seasons; as ivy 6 or 8 feet high may be purchased in pots in quantities, and as soon as it was planted it might be trained over the wire frames, so as to form arcades, pyramids, cones, candelabra, statues of the human figure or of animals, the second season after planting; that is, if the ivy were planted in April, 1841, the framework would be sufficiently covered to show the effect by July, 1842. In the mean time, the effect might be tried by putting up the wirework and tying shoots of ivy to it; as indeed might all other contemplated artificial forms. The situation, we understand from the gardener, is a good deal exposed to high winds; but these would not injure the ivy in the slightest degree, as it is one of the hardiest of plants. The common juniper, the red cedar, the arbor vitæ, the furze, and the spruce fir, grow rapidly, and may be cut into any shapes. The spruce fir forms most beautiful arcades, hedges, and candelabra, at the Whim, near Edinburgh, engravings from which are given in vol. iv. of our *Arboretum Britannicum*, under the head of *Abies excelsa*.

It would be a great improvement to the grounds at Trentham, if the whole of the water could be lowered 5 or 6 feet, as at present it has too much the appearance of an overflowed meadow. The islands are also too large, or, at least, too much in the middle. Were the water lowered, the banks might be enriched, in some places, with blocks of stone, to imitate the jutting out of rocks from the subsoil. It did not occur to us, when on the spot, to ask whether the channel of the river, which takes the water from the lake, could be deepened. If it could, even suppose it were necessary to extend the deepening over a distance of 2 or 3 miles, the improvement to the whole place, as it appears to us, would be very great indeed.

East Combe, near Blackheath; Dowager Countess of Buckinghamshire. — June 16. This is one of the most delightful places in the neighbourhood of London, though but little known. The house stands only a few yards from

the public road, but the grounds are extensive and extremely varied. A very steep bank descends from the house, in the form of a beautiful lawn, varied, first, by flower-beds, next by groups of rare trees and shrubs, then an apparently dense mass of wood, beyond which is seen the windings of the Thames, continually varied by shipping. The Thames is sufficiently near to give the idea of its belonging to the place, and forming its boundary, and the bends of the river are seen lengthwise, rather than directly across. Such is the view from the principal garden front. The other view looks on a level lawn, varied by flowers, and terminating in fine old trees. A walk leads in this direction to a shady but airy avenue, on a level, an admirable place for recreation during the hottest weather of summer, and to a terrace walk which forms the circuit of the place. The taste of the owner is advantageously displayed on the lawn by the small size of the beds, circular or roundish, and their disposition into groups or constellations, which, as may easily be conceived, form a new combination with every change of the spectator. This is by far the most effective way to display flowers on a lawn, whether on a large scale or a small one. The little circles of flowers ought to be considered as trees and shrubs, and distributed over the surface, exactly on the same principle as trees are distributed over the surface of a park. The kitchen-garden we found well cropped, and the whole place in good order. Strawberries planted on a surface sloping to the south, at an angle of 45°; the soil being loamy, and the surface covered with flat tiles, ripen three weeks earlier than on a flat surface. Fig trees and morello cherries against walls are found to produce most fruit when only the main branches are laid in, and the small fruit-bearing shoots of the past year allowed to stand out from the wall. The paradise apple is here raised by cuttings, and the plants, treated like gooseberry bushes, produce enormous quantities of fruit, which, though not fit for the dessert, is useful for culinary purposes. *Agapánthus umbellatus* attains an extraordinary size in pots, which the gardener, Mr. Cockburn, attributes to his shifting the plants once a year, shaking off all the soil, removing the offsets, and replacing the plants in light rich soil quite loose, neither firming it with the hand nor by the pressure of water poured from a pot held as high as a man can reach. Annual flower seeds, and also potatoes, salading, and other articles, are raised on dung beds without sashes, mats being thrown over them, supported by hoops, only when extraordinary cold nights are anticipated. The Kew pine strawberry is here found to bear almost as well as Keen's seedling.

Woodlands, Blackheath; J. Angerstein, Esq. — We looked at this place with a melancholy interest, recollecting the extraordinary sensation which it made in the horticultural world when we first saw it in the year 1803. At that time David Stewart, Esq., Land Agent, and Landscape Gardener, of Great Russel Street, was then head gardener, and so great was his reputation, that in a biography of living characters which was published about that time, and included notices of all the principal men of the day, it is said, when speaking of the late J. J. Angerstein, that he was "fortunate in having for his gardener Mr. David Stewart." We have noticed Mr. Stewart's high talents as a landscape-gardener, in speaking of Bearwood, in our volume for 1833, p. 679.

Charlton House, Sir Thomas M. Wilson, Bart., is a noble mansion in the Elizabethan style, or rather perhaps in that of James I., as it contains more of the Roman or Italian than the earlier Elizabethan, which partakes more of the domestic Gothic. The house is undergoing some changes, which we hope will not be carried so far as to influence the exterior appearance of the general mass. Some additional ground has lately been acquired on the entrance front, and this having given an opportunity of making a new approach, the great mistake was committed of forming it in the modern style, thus counteracting, as far as possible, the first impression made by one of the finest old houses in England. The garden front was formerly thickly embosomed in yew trees, which have been headed down, but they would be

much better entirely removed. We have seldom seen a place with the grounds in a worse state from neglect, but they contain at the same time the elements of every thing desirable for such a situation. Would that we had the re-arrangement of them, with a *carte-blanche* as to moving ground, and forming an approach and terraced gardens.

Belford, — *Mercer, Esq.*, is a place full of variety in the grounds, but at the same time without distinctive character in the different parts. One hill and valley succeeds another, all varied by natural wood in a similar manner, while there are different ravines and deep gullies which have been formed by digging out sand, gravel, or chalk, and these might be arranged in imitation of romantic Swiss scenery. In short, there are here the germs of an almost endless succession of scenes of singular beauty and character; alpine heights, and Swiss valleys. Nothing has been done to the place for many years, and the keeping is of the worst kind, with the edges of the walks as deep as cart ruts.

Belvidere, near Dartford, Lord Saye and Sele, is a noble place. The house is situated on a piece of table land, bordered by a range of inequalities of surface skirting the alluvial plain of the Thames, and commanding delightful views of that noble river, and the country beyond. The house has no merit in an architectural point of view exteriorly, but it contains one room fitted up in the style of Louis XIV., which is altogether one of the most complete things of the kind in England. It is 35 ft. long, 25 ft. wide, 30 ft. high, and appropriately finished and furnished. Exterior facings to the windows, and other architectural decorations, with a terraced garden, for which the situation is peculiarly adapted, would render this a singularly fine place. There are extensive walks reaching for miles along the summits of the wooded banks, and every now and then opening to the river, and sometimes descending to the lower grounds. The wood is chiefly the remains of a natural oak forest, and the soil being very thin on chalk, the roots, which ramify from the old trunks and stools of what had formerly been coppice wood, spread over the surface like network, showing in a strongly marked manner the advantage of planting above the surface rather than under it. There is a fine mixture of hollies, laurels, junipers, red cedars, and other evergreens, among the oaks, and there are some open glades covered with the original heath, in the same state in which they have probably been for ages. Though there are only about 150 acres in the park, yet there are upwards of two miles of walks. These are 10 ft. in width, with low flat grass edgings clipped, but not pared with the spade, and though no family has lived here for a number of years, yet they are kept in the highest order. There is a flower-garden in an extensive glade in the woody scenery, which comes in as a fine relief to the general character, though the flower beds are much too large, and far from being connected into a general system. There is a small pinetum, unfortunately planted under the shade of the native oaks, and therefore never likely to produce any effect. The native oaks are wholly of *Quercus sessiliflora*.

West Heath, — *Preston, Esq.*, is a thatched cottage, entered through a conservatory, and with an exterior form that an architect with an artistical eye might turn to fine account. Showy beds of flowers abound on the lawn, but they are much too large, and for that reason make the place appear smaller than it really is; so much depends on proportioning all the details of a place to the whole.

In returning, we observed two frightful chapels; the Hanover Chapel at Peckham, in the form of a pentagon, with small mean windows without facings, and red brick walls without cornices or any decoration whatever; and another chapel nearer Camberwell, of larger size, with similar walls, with three or four stories of naked windows like those of a third-rate dwelling-house. Chapels, in general, throughout the country, are at present a disgrace to it in an architectural point of view; but it is to be hoped that the spread of knowledge and taste will raise them to a par with other religious buildings. Mr. De Crespigny's house at Peckham is a fine old brick building.

Harringay House, near Hornsey, (June 17.) is one of the finest villas in that part of the suburbs, in point of situation. The house occupies the summit of a knoll, and, half-way down, the New River winds round it on three sides. Agreeably to the old style of laying out places of this kind, the entrance front is on that side of the mansion which contains the finest views, so that a stranger visiter sees every thing worth seeing in point of scenery before he alights from his carriage. Something has been done to counteract this, by a fringed line of trees in the fore-ground, close to the gravelled area for turning carriages on, or what may be called the arena of honour, so that the full enjoyment of the fine views is reserved for the walks in the pleasure-ground. This arrangement constitutes the merits of the place as a study for the young landscape-gardener. To those like us, who have known Harringay for the last twenty years, it is interesting on account of the numerous specimens of rare American trees and shrubs which it once contained, and of which there are still some interesting remains. *Magnolia macrophylla*, which had attained the height of 20 ft., and flowered frequently, still exists, but was much injured by the winter of 1837-8. *M. conspícua* and *M. c. Soulangeana* are 20 ft. high, and flower freely every year. There are various other fine specimens, and the place is kept in good order.

Arno's Grove, Southgate, the residence of Mrs. Walker, is a place which we should wish to visit several times every year, not only on its own account, but because of the beautiful road to it, bordered, as it is, great part of the way, by an undulating country and noble trees in park-like scenery. The collection of trees and shrubs here, at the time the place was planted, has undoubtedly consisted of every thing that could be procured in the London nurseries, for the proprietor, like the late Mr. Gray of Harringay, was the friend of Collinson, Ellis, Dr. Fothergill, and their contemporaries. The specimens of *Quercus palustris* here, which we have before mentioned, are alone worth an annual visit; not to speak of the purple-branched oak, the Oriental plane, the magnolias, the cedars, the immense berberry, the *lagerstrœmia* against the conservative wall, which has resisted the winter of 1837-8 without the slightest protection, and many other hardy and house plants. By the side of the walk which leads from this place to Minchenden, we observed *Collinsia grandiflora*, and a number of other foreign plants, apparently naturalised.

At Woodlands, the residence of — Taylor, Esq., the fine old conservatory built by Mr. Nash has been pulled down, and the lawn and pleasure-grounds, so highly kept in former times, are now in a state of comparative neglect.

—— *Park, near Enfield, the seat of ———,* is a romantic solitary place, formed amid forest scenery of apparently unlimited extent, and having altogether the character of a grand place in a distant part of the country. The approach to the house is first through a long straight avenue, and afterwards through forest scenery untouched by art. The water and woods beyond, as seen from the lawn front of the house, are perfect of their kind, but the walks in the pleasure-ground are on too contracted a scale for so large a place. They ought to stretch away right and left to an apparently interminable distance. An attempt has been made to earth up and plant out the stable offices or farm buildings, which, according to our notions of a fine old English place, is not in good taste. We would avow them, but blend them with the general scenery by means of a few scattered trees. Of all the different modes of concealing buildings, that of raising mounds of earth close before them appears to us the worst, because it takes away from the dignity of the building; and every building, even a cowshed, has a character more or less dignified. A great place is rendered little by any direct attempt at concealment.

Beech Hill Park, near Potter's Bar, now (July, 1840) on sale, is a large open place occupying two immense banks, and the hollow between them. It is capable of vast improvement, but not without great changes both in the house and the approach.

Leamington, Warwickshire, (Sept. 19. to 21.) has increased one half since

we last saw it in 1831, both in population and in the extent of ground covered by streets and buildings. There are a number of suburban and town villas, many commonplace, others ambitious and showy, some rich in decoration, and a few elegant and correct. There is a piece of ground containing about 14 acres, which is intended to be laid out as a public garden, and for which we have made a plan. On a few of the villas, of which we took a rapid glance, we shall say a word or two from recollection.

Bradley House, H. Bradley, Esq., is a town or street garden, the house being part of a row. The ground behind consists of about a quarter of an acre, and includes green-houses, vineries, peach-houses, and various architectural and sculptural ornaments. There is a wall with fruit trees like that of a kitchen-garden, and a lawn varied by flower beds, a basin and fountain, some trelliswork, and a terrace with steps. In point of design, the merit is not great, but the whole is very highly kept. That we may not find fault without assigning a reason, we may observe that the great art in making a small garden appear large, is to prevent the spectator from walking in the middle, so as to see the whole at once; and, in the case of a town garden surrounded by walls, it is mostly desirable to conduct the spectator from the house under a boundary colonnade, or other architectural walk for warm weather, having at the same time open winter walks. The flower beds here are also of too fanciful and angular shapes for the manner in which they are planted, and too large for the situation. Wherever flowers or roses are allowed to grow to the height of 2 or 3 feet, groups of small circular beds will generally be found preferable to other shapes; but where plants are not to rise higher than 6 in., irregular or composite forms may be adopted; because, in consequence of the lowness of the plants, the shapes of the figures may be recognised by the eye. The commonplace character of the surrounding wall and of the hot-houses, and the want of unity of system among the flower beds, are the positive faults of this place; and the negative fault, or omission, is, the want of a surrounding architectural walk, somewhat in the manner of the mural colonnades in the town gardens of Pompeii. A garden of this kind is much more difficult to manage than one round a detached building, because it demands not only an artistical but an architectural eye.

Beech Lawn, Dr. Jephson, is a suburban villa, of several acres, with an excellent square house, and grounds sloping down from it on three sides. On the entrance front, the lawn is separated from the gravelled area on which carriages turn, by a ridge of rockwork 3 or 4 feet high, richly planted with flowers. This is intended to keep off dogs from the lawn, and appears to be a good idea for similar situations. Besides a pleasure-ground planted with a considerable variety of trees and shrubs, there is a small fruit-garden, and an excellent kitchen-garden, with a vinery, peach-house, pine-pits, &c.; the whole, with the exception of the turf edgings of the walks (which are too narrow, and pared with the spade instead of being cut with the shears), well kept. A great improvement to this place would be, a terrace and Italian flower-garden to connect the house with the lawn. The magnitude of the house, its architecture, and the elevated situation on which it stands, particularly point out this style of decoration; besides, it would have been something new in Leamington, where all the gardens are formed on one type. Among the trees planted are some beautiful specimens of Turkey and Lumbe oaks of several varieties.

The Priory, the Rev. John Craigs, is a small town villa, bordering the river Leam, now being laid out and planted by Mr. Cullis, who has very greatly improved the situation, by raising the surface above the level of the river. There is a descent from the principal floor of the house to the garden, by a flight of steps through a mass of rockwork; a good idea, but not carried out in the best manner, partly from want of proper materials. To have managed this rockwork artistically would have required larger blocks of stone than have been used, and the total omission of scoria, vitrified bricks, and indeed of every species of stone except one. There is not a point in the whole

course of ornamental gardening that is so little understood as the formation of rockwork. Most creations of this kind are little better than rubbish heaps, because they appear to consist of all the sorts of stones that are found lying about in the locality, including vitrified bricks, brickbats, shells, roots, &c. No man can form a rockwork that has not the eye of an artist; and, if all the best rockworks in England were examined, it would be invariably found, that each consists only or chiefly of one kind of stone. Compare the rockworks of the last century at Pain's Hill, Ascot Place near Windsor, Fonthill, Wardour Castle, with those erected at the Coliseum, London, under the direction of Mr. Gray, and with those of Lady Broughton, at the Hoole near Chester, and of Mr. Wells at Redleaf. In none of these rockworks will there be found a miscellaneous assemblage of materials heaped up; but, on the contrary, blocks of stone of one kind, or imitations of blocks of stone, are ranged so as to assume some natural-looking character of stratification or position. We repeat that no man who has not the eye of an artist should attempt rockwork.

The roof of a low portion of the house, looked down on from the library windows, Mr. Cullis has very ingeniously covered with a collection of low-growing saxifrages; and, on the whole, this place does him much credit.

Holly Walk is a street finely bordered with old oaks, elms, and hollies, some of the latter having trunks 2 ft. in diameter, and the oaks and elms 6 ft. There are several villas in this street deserving notice, particularly one in the Elizabethan style, called Oak House, and another in a sort of Indian Gothic, the residence of T. S. Hellier, Esq.

Danby Cottage, the residence of *John Williams, Esq.*, in the interior of the town, is a villa in the Gothic style, handsome, and surrounded by fine trees.

Radford Cottage, the residence of — *Squerell, Esq.*, architect, is an example of the Elizabethan style, admirably worked out, in all the exterior details of the house, offices, boundary walls, and gates; and, as we passed rapidly by it, it appeared to us one of the best things of the kind in Leamington.

Mr. Cullis's Nursery extends over many acres in different parts of the town and neighbourhood, the progress of building compelling Mr. Cullis every now and then to retreat further and further into the country. The seed shop, conservatories, and house garden are still, however, in the same situation in which we saw them in 1831, as noticed in our volume for that year, p. 410. The conservatory was then being planted, the more rampant-growing sorts being placed in bottomless pots, resembling chimney pots, 6 or 8 inches in diameter, and 2 or 3 feet in length. After nine years' growth, and notwithstanding annual prunings, the plants, as may always be expected, had become too large, or too disproportionate to one another. They were, therefore, recently taken up, the soil entirely renewed, and a collection of young plants planted in the same manner as before. Every conservatory, to be kept in the best manner, ought to be taken up and replanted every seven or eight years, and we think the whole mass of soil ought to be separated by concealed perpendicular divisions into squares proportionate to the bulk of the plants which are to be planted in them. Mr. Cullis's mode is excellent for a nursery conservatory, where the object is to display as many kinds as possible, on a small space; but, for the conservatory of a private gentleman, more effect is produced by a few choice specimens clothed with branches and foliage from the ground upwards, than by a crowd of species drawn up by one another. For such specimens, a considerable extent of surface is necessary, not only to admit of their growth and bulk, but to promote the ripening of the wood and the formation of flower buds; and hence dividing by rectangular partitions is preferable to planting in bottomless pots, as giving more room for surface roots; because, without these, large plants can never be expected to flower well. Mr. Cullis has a very considerable collection of hardy trees and shrubs, and among these is the largest stock in England of *Cupressus torulosa*, all in pots, and between 2 ft. and 4 ft. in height.

Leamington, like most other country towns in England, is laid out more at random than on any definite system; nevertheless, the streets are broad, and

for the most part straight : but to a stranger there is no obvious leading street or streets, and the houses are numbered in the common and inconvenient manner, by which we mean that there is no fixed and understood end, such as the east or the north, at which numeration should commence, and no separation of the odd from the even numbers, as is now being done in London, and as has been practised in France since the first revolution. There is much municipal arrangement and regulation in Paris that would be of great benefit to the public if adopted in English towns, and more especially in those which are rapidly increasing, such as Leamington, Cheltenham, Brighton, &c. To be convinced of this, it is only necessary to look into the *Guide to Paris*, and the map of that city.

Theobalds, near Waltham Cross ; G. H. Heppel, Esq. — Sept. 27. This is a small place, but displaying on the lawn, on both sides of the house, exquisite taste, and in the kitchen-garden most judicious and successful culture. The house, which is an old cottage, was occupied for many years by W. Wingfield, Esq., a master in chancery, and the grounds which were laid out by him do the utmost credit to that gentleman as an amateur artist. The lawn consists of only two narrow strips of ground, of about an acre each, on two opposite sides of the house, and on these the taste and skill of Mr. Wingfield have been displayed in laying them out. In the one lawn, a broad open glade is preserved down the centre, with a walk surrounding it concealed from the house by shrubs, trees, and small, raised, roundish, distinct beds of flowers which form, as we pass them on the marginal walk, varied foregrounds to oblique views athwart the lawn. In the strip of lawn on the opposite side of the house, there is a straight gravel walk down the centre ; and the lawn on each side is covered with beds of flowers, so as, in fact, to constitute this lawn one entire flower-garden. The contrast between the two lawns thus treated, is striking and delightful. The trees and shrubs which form the marginal foreground to the first lawn are of rare and beautiful kinds, and they are admirably disposed, advancing into the lawn and retiring to the walk, and even behind it into the marginal plantation, so as to produce marked, but not formal, prominences and recesses ; and, looking at these more in detail, we find an endless variety of groups. The extremity of this lawn is bounded by a public road, and to disguise this boundary it is ingeniously contrived to have two returning walks at the end, one separated from the other by a narrow plantation of shrubs and flowers, in consequence of which the immediate proximity of the boundary is never once suspected by the spectator, who, seeing that there are two walks, concludes that there is no want of room ; and, therefore, the idea of a boundary in that quarter never occurs to him. An

idea of the position of these two walks is given in *fig. 70.*, and the hint therefore, we trust, will not be lost on young landscape-gardeners. In this lawn, breadth of effect is preserved by no beds being placed down the centre, and the side scenes are varied by the position of the trees and shrubs, and their different kinds producing different sizes, shapes, and characters of foliage.

In the lawn on the opposite front of the house the side scenes are also varied

by trees and shrubs ; but breadth of effect has not been attempted, the lawn being almost equally covered with beds throughout, and the central walk having

70

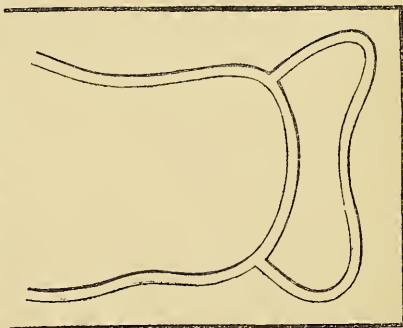

arches of trelliswork with creepers placed across it at regular distances. The beauty of this lawn, therefore, is not to be tested by the same associations as that of the other lawn; and, while the latter is to be considered as addressing itself to the painter, the former addresses itself to the florist. The beds are for the most part raised, and many of them have edgings of wire or trellis work, naked or covered with ivy, honeysuckle, sweet briar, or other fragrant or ever-green shrubs.

Bayfordbury, near Hertford; W. R. Baker, Esq.—Sept. 28. This is a splendid place, the lawn of which, and the park scenery beyond, have been laid out with as exquisite taste, on a large scale, as the lawn at Theobalds is on a small one. We have not seen two places so much to our mind in the course of the summer. The house is in a commanding situation, in a park at Bayfordbury, which probably contains near 1000 acres; and in the vicinity of the house the trees and shrubs are arranged in a manner which leaves scarcely any thing to be wished for. The house itself has nothing to recommend it in point of architecture, but it is grand and imposing by its magnitude, and most commodious and convenient by the number, arrangement, and ample size of the rooms. The principal dining-room and the library are remarkably well proportioned, and the walls of the former are covered by a unique collection of portraits of the members of the Kit-cat Club. The bed-rooms are arranged in three distinct divisions, each division having a well-lighted central passage, as an axis. The division on one wing over the kitchen offices contains all the family apartments, nurseries, &c.; that in the opposite wing, for bachelors and gentlemen without families; and that in the centre for strangers with families, and stranger ladies. The principal and servants' stairs to each of these divisions are quite distinct. All the offices and servants' rooms are above ground, which gives the windows of the living-rooms a commanding view over the park, both on the entrance and lawn front, without which, indeed, there can be no grandeur of effect. The living-rooms on the lawn side open under a deep central portico; and to the right and left is a broad balcony, which extends the whole length of the living-rooms, and descends to the architectural flower-garden at each end by a flight of steps. The descent from the central portico is to a broad terrace walk, between which and the house is the architectural flower-garden just mentioned. But, lest it should appear tedious to continue a description which must fail to give an idea of the beauty and magnificence of the place, we shall conclude by observing that the situation of the house, its general mass, and the position of the flower-garden, remind us of Stowe; but that the lawn and its treatment at Bayfordbury are altogether superior.

A very complete pinetum has been planted; and an arboretum is commenced, by distributing the larger-growing trees and the thorns throughout the park, and placing the smaller and more delicate trees and the shrubs in a plantation by themselves, which will be so arranged that every species can be seen in succession. There are a number of fine old cedars on both fronts of the house, which have been planted about the middle of the last century, and spruce and silver firs, larches, oaks, and yews of the same date. In the lawn, and also in the arboretum, are a number of specimens of *Araucária imbricatá* of vigorous growth, from 1 ft. to 6 or 7 ft. in height, which have never received the slightest protection. There are also several large specimens of *Picea Webbiána*, *Pinus Sabiniána*, and *P. macrocarpa*, and various other rare kinds. There is, indeed, no species of *Abiétinæ* or *Cuprèssinæ* in the country, of which there is not one or more plants in the collection here; and they have all been planted on raised hills of prepared soil, and are thriving accordingly. Mr. Baker has tried with success the *greffe herbace*, and intends next year to make a great many trials on the summits of Scotch pines, common spruces, and silver firs, of 10 or 12 feet in height. Perhaps *Picea Webbiána*, grafted at this height, or even at a greater height, might escape the spring frosts. It is interesting to observe here, on the lips of the wounds of the stock in the case of grafts which had failed, buds emitted in the heart of the sheaths of eaves, thereby proving that each tuft is an abortive shoot.

The lawn is separated from the park by a sunk fence, which in one part of the grounds affords an excellent hint. The natural surface is hollowed out, the fence is made in the bottom, and a bank formed on the park side and on the lawn side; the walk is formed near the top of the bank on the lawn side, in consequence of which the opposite bank rises above the eye and absorbs the attention of the spectator, who appears walking on the side of a natural hollow. The fence is thus altogether lost sight of, or at all events does not attract attention in the offensive manner which it does when made on a level

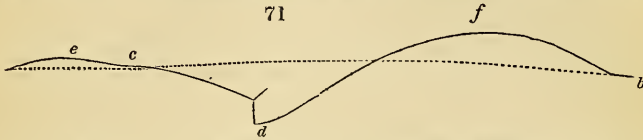

surface. In *fig. 71*, *ab* is the line of the natural surface, previously to sinking the hollow; *c* the walk; *d* the sunk fence, with a light fence of strained iron wire at top; *e* a bank raised in the pleasure-ground; and *f* a bank raised in the park. Of course, this description of sunk fence can only be adopted in particular situations in small places, but in large ones it might be of frequent adoption.

The beds on the lawn are not to be considered as forming a flower-garden, but as low growths connected with the trees, and harmonising with them and with the distant scenery. They are all of roundish shapes, and mostly circles varying from 1 ft. to 6 or 8 ft. in diameter. They are almost all planted with low flowering shrubs, and with occasional low trees, such as rhododendrons, azaleas, and heaths; and the shrubs have almost everywhere spread sufficiently to cover the dug surface, and project over the lawn so as to break the boundary line, which is exactly what is desirable in such a situation. The smaller circles are filled with heaths, vacciniums, andromedas, the lesser rhododendrons, *Arctostáphylos*, *Gaulthéria Shállon*, &c.

In a large conservatory there are some fine fruit-bearing specimens of the mandarin orange, the pulp or sarcocarp of which separates from the skin or epicarp as a filbert does from its husk; and of a most agreeably tasted yellow-fleshed orange, brought from Malta by Mr. Baker, which we have not seen elsewhere. At the south end of the mansion there is a wall covered with orange trees, and in the border in front are many half-hardy herbaceous and suffrutescent plants. The wall and border are protected by a roof and front, consisting of sashes of thatch instead of glass, which take out or slide between rafters like the sashes of a green-house; and by which air and light can be given and taken away every mild day, with rapidity and ease, while the thickness of the thatch is such as completely to exclude frost. The wall against which the trees are trained, being the side of one of the office buildings, it cannot be assailed by frost in that quarter. There are many interesting scenes, such as rockwork, summer-houses, flower-gardens, aquariums, trelliswork, in the pleasure-ground near the house, which we cannot stop to describe, and also many fine specimens of old trees, the family having been devoted to planting for three generations.

The kitchen-garden is a mile from the mansion, having been formed for a dwelling-house, which was taken down some years ago. It is well managed, as are the numerous forcing-houses, pits, and frames, and the adjoining tree nurseries. We saw here a great many plants raised from seeds of *Mahònia Aquifòlium*, varying in foliage in an incredible manner, and some of them decidedly *Mahònia repens*; a proof, as it appears to us, of the correctness of Messrs. Torrey and Gray, in the *Flora of North America*, of making this alleged species only a variety; and the same circumstance accounts for Mr. Rivers having found the distinct seedling which he describes in our vol. for 1839, p. 235. It may be alleged that some seeds of *M. repens* had found their way among those of *M. Aquifòlium*, or that the flowers of the latter had

been accidentally fecundated by those of the former, but we are assured that neither of these circumstances took place.

In the remains of the old pleasure-ground which connected this garden with the former mansion, are some remarkably large larches, silver firs, and cedars, and an avenue of the largest lime trees which we remember to have seen. Those at Syon are probably as high or higher, but at Bayfordbury one tree occupies the space of at least a dozen of these, either at Syon or at Wollaton. Several cedar trees have been felled or blown down at different times, and the boards being used for flooring, they still give out a resinous odour. The branches make a delightful drawing-room fuel, where the fire-places are adapted for burning logs, as they are at Bayfordbury. When cedar wood is burnt in an entrance hall or staircase, its fragrance is diffused over the whole house. In every case the fragrance is most felt when the atmosphere is in a moist state, because then the radiation of the particles is checked by the vapour of the water in the atmosphere.

Kew Gardens.—Oct. 3. We never saw these gardens in better order. Our main object in visiting them at present was to view the ruins of the finest of the cedars. This tree, in the course of the last ten years, had lost several large branches from falls of snow and storms of wind; but on the 4th September, 1840, at 4 o'clock in a calm morning, after a shower of rain, an immense branch, which had not previously been in the slightest degree rent at its junction with the trunk, gave way, and fell down from the height of 40 ft., with such a tremendous crash, that it awoke Mr. Smith, whose house is within 200 yards. The additional weight given by the rain to the branch had no doubt occasioned its fall, like the additional handful of hay which broke the camel's back. This branch having been more exposed to the light and air for some years past, in consequence of the other branches having broken down, and having also a larger proportion than before of the sap thrown up by the roots, it must of course have grown more rapidly at the extremities, which, by increasing the weight at the end of the lever, led to the destruction of its equilibrium. We observed here, and also afterwards in the Horticultural Society's Garden, that *Pinus Sabiniàna* and *P. macrocárpa*, as they advance in size, become more and more different in the appearance of their bark; that of the young wood of *P. Sabiniàna* being smooth, with the persistent scales of the leaves adpressed and regularly imbricated, while those of *P. macrocárpa* are furrowed, rough, more vigorous, and the scales less adpressed and imbricate. The latter tree is much more robust than the former, and also more glaucous. A cone has been received at Kew of what is believed to be the true *Pinus Coultteri* (see p. 550.), from which plants have been raised, and hence that species may be considered as now in the country. In due time we shall give in this Magazine descriptions and figures of this and all the newly introduced species of *Pinus*. *Héimia salicifolia*, a shrub, a native of Mexico, which is now 3 ft. high, and covered with fine ochre yellow flowers, is considered by Mr. Smith as quite hardy. *Leptospermum*, two species, natives of Van Diemen's Land, are also found quite hardy; and a *Tasmánia*, from Mount Wellington, in the green-house, and a *Drimys Winteri* (Winter's Bark), from the Straits of Magellan, now in the conservatory, may be expected in a few years in nurserymen's lists of hardy shrubs. It does not appear to be known at Kew what the intention of government is respecting these gardens, but we do hope that, whatever changes may take place, justice may be done to Mr. Smith, whose modest merit is acknowledged, by every botanist and gardener, to be beyond all praise. If Mr. Aiton should resign, and any other person be appointed to fill his place except Mr. Smith, an act of injustice, and still more of impolicy, will be performed, which it is revolting to the mind to think of. With respect to describing the new plants, Mr. Smith has proved himself, in Hooker and Bauer's *Genera Filicum*, now publishing, as competent to do that as any botanist whatever; but it does not appear to us that government need trouble itself about describing plants at all; it has only to leave the collection open to the examination of all botanists, and provide a clerk for

carrying on, under the direction of Mr. Smith, a correspondence with the public botanic gardens, British and Continental. An intelligent gardener, an old workman in these gardens, and who has been lately visiting the gardens of the metropolis, has sent us the following paragraph respecting them :—

“A difference of opinion appears to exist in regard to the sum required to make this garden useful as a botanic garden; from my own experience I am inclined to believe that much might be done even with the present allowance. But surely an additional 1000*l.* a year might be spared for sending botanical collectors abroad. I cannot but think that part of the sum which appears to be yearly expended in repairing the present hot-houses, would be better employed in enlarging and otherwise improving them; and this might be done gradually, beginning with the palm-house, which, at present, is altogether discreditable to the garden. It is with no ordinary feelings that I behold my old friends, the fine old palms in this house, gradually going to decay; and I do hope that, before long, something will be done before they are irreparably lost.—*J. W.*”

Mr. Willmot's Gardens, Isleworth.—*October 3.* Having seen the chunk-stove advertised as being used by Mr. Willmot with great advantage, we called to see it. The stove is small, portable, placed within the house (a vinery), and burns only coke or cinders. The fire is placed in one cylinder, which is surrounded by another, and the air, which enters at the bottom and passes up the space between, being there heated, is distributed along the front of the house in two perforated tubes proceeding right and left from the stove. The fuel is supplied from the top by a very ingenious contrivance, viz. a box the bottom of which is fitted exactly to the upper orifice of the fuel chamber; and being filled with fuel, the bottom, which slides in grooves, is drawn out, and the fuel is dropped into the fuel chamber without the admission of smoke or dust into the house. Before the fuel box is removed, the cover of the fire chamber, which also slides in grooves, is pushed in and thus replaced. The smoke from the coke or cinders passes through the front wall of the house in a sheet-iron tube of about 3 in. in diameter, and the hot-air tubes are of the same material and dimensions. To counteract the effects of the dry heat produced, a tin tray filled with water is placed over each tube, so as to be in contact with it and evaporate the water. There can be no doubt but that this is a very economical mode of heating, not only with reference to the first cost of the apparatus, but to the daily cost of the fuel; but it has two disadvantages. In the first place, the dry heat produced is unfavourable to vegetation, and cannot easily be rendered moist, because the heat issues in the form of streams of hot air; and not by radiation, from the surface of heated tubes, as in the case of smoke, water, or steam, confined in flues or pipes: and, secondly, should the fire be stronger at any time, from any accidental circumstance, such as better cinders or coke being used, or the smoke funnel and the inside of the furnace being newly cleared out; or should a very mild night unexpectedly occur; then the quantity of heated air suddenly produced will be so great as to overheat the house, and greatly injure the foliage of the plants. On the other hand, if the fire were to go out unexpectedly, there is no sufficient reservoir of heat, as there is in the case of flues or hot-water pipes; for the heat in the fuel, after the fire is gone out, is rapidly carried off by the circulation of the air. We admit that, by great care on the part of the gardener, this may be mitigated; but, from the mode being liable to accidents of this kind, it cannot be generally recommended. For heating a house or pit where there are no flues or other means of heating, it may become a useful expedient. However, if we have not done justice to this mode of heating, we are open to the corrections and reasoning of Mr. Willmot.

The Horticultural Society's Garden.—*October 3.* We have little to add, respecting the conservatory, to what we have said in our preceding volume, p. 351. and 352. The workmanship is excellent, and the plants are looking well, but the structure, considered with reference to design and taste, is, in our humble opinion, objectionable to a degree that would justify the use of much

stronger language than we could apply, without the risk of being accused of bad feeling on the subject.

It is difficult to conceive anything worse than the entrance at the west end, which forms the terminating object to a straight walk. We are totally ignorant to whom the design of this mode of descending and entering is to be attributed, but this we will say, that if any private gentleman's gardener had committed such a blunder he would have deservedly lost his place. How different might have been this entrance, if the parties connected with the placing of the building had only taken the levels of the ground, and considered the structure with reference to all the details connected with it, such as the west entrance, the boiler, the hot-water pipes, the surrounding terrace, &c., previously to putting it down! Even admitting that it had been determined to enter this large hand-glass, as it may be called, under the rim, how different would the appearance have been if this rim had been raised a few feet higher? The heating pipes, in that case, might have been placed under the level of the path, and a current of air established, not by communicating with the open air, as is now done, but with the air of the house, in Mr. Kewley's manner; reserving the power of admitting the exterior air also among the pipes at pleasure. Besides this mean entrance, we have a hideous chimney to the hot-water apparatus. Surely this object might have been built in better taste. Even the commonplace idea of a Grecian column, carried into execution so as to produce a very striking effect at the Coventry railway station, and not higher than the chimney in the Horticultural Society's Garden, would have been incomparably better. At present, the little zinc tube, stuck into the thick clumsy mass of composed brickwork, reminds us of the third-rate houses of the suburbs. But we object altogether to entering this structure under the rim; and we also object to the tameness and monotony of the round end, which would have been relieved by a porch, either of glazed work or of masonry. These remarks should have been illustrated by a section, to show the descent into the west entrance; by a ground plan, to show that this west entrance forms a termination to a straight broad walk; and by a view, to show that the sides of the descent are decorated with some stones in the way of rockwork, unworthy of the dignity of architecture, but certainly very well worthy of the scene of which they form a part.

In the arboricultural department a great many new pines and other ligneous plants have been raised from seeds sent home by M. Hartweg, with the greatest success, by Mr. Gordon. The taste which the Society is creating for rare and beautiful trees and shrubs throughout the country, by the distribution of the seeds of plants sent home by their collector, and of the plants raised in the garden from these seeds, is a redeeming point in its character; and must be considered, along with the *Catalogue of Fruits* prepared by Mr. Thompson (known throughout Europe and North America as perhaps better skilled in fruits than any other man in existence), and the distribution of grafts of selected and new fruits, as veiling the sins of the garden with reference to design and taste.

ART. II. *Botanical, Floricultural, and Arboricultural Notices of the Kinds of Plants newly introduced into British Gardens and Plantations, or which have been originated in them; together with additional Information respecting Plants (whether old or new) already in Cultivation: the whole intended to serve as a perpetual Supplement to the "Encyclopædia of Plants," the "Hortus Britannicus," the "Hortus Lignosus," and the "Arboretum et Fruticetum Britannicum."*

Curtis's Botanical Magazine; in monthly numbers, each containing seven plates; 3s. 6d. coloured, 3s. plain. Edited by Sir William

Jackson Hooker, LL.D., &c., Professor of Botany in the University of Glasgow.

Edwards's Botanical Register; in monthly numbers, new series, each containing six plates; 3s. 6d. coloured, 3s. plain. Edited by Dr. Lindley, Professor of Botany in the University College, London.

Paxton's Magazine of Botany, and Register of Flowering Plants; in monthly numbers; large 8vo; 2s. 6d. each.

The Botanist; in monthly numbers, each containing four plates, with two pages of letterpress; 8vo; large paper, 2s. 6d.; small paper, 1s. 6d. Conducted by B. Maund, Esq., F.L.S., assisted by the Rev. J. S. Henslow, M.A., F.L.S., &c., Professor of Botany in the University of Cambridge.

RUTACEÆ.

+ LEMONIA Lindl. LEMONIA. (In honour of Sir Charles Lemon)
spectabilis Lindl. beautiful ✨ □ or ... au C Cuba 1839. C co. Bot. reg. 1840, 59.

A beautiful stove shrub, imported by Messrs. Loddiges from Cuba, which produced abundance of dark crimson blossoms in August last; and which Dr. Lindley has named in honour of Sir Charles Lemon of Carlew. (*Bot. Reg.*, October.)

1154. CORRÆA [vii. p. 195.]
longiflora Hort. long-flowered ✨ □ or 1 d Pk hybrid 1838. C p.l Paxt. mag. of bot.

One of the beautiful hybrid corræas raised by Mr. Milner of Stockwell, which is now in the hands of Messrs. Lucombe, Pince, and Co., of the Exeter Nursery. This plant is "less luxuriant and robust than most other hybrids, and is far more prolific in flowers." It was one of the first reared. It is generally propagated by grafting on *C. speciosa* or *C. pulchella*, at not more than 3 in. from the base of the stem, and keeping the plants in a slight heat. Ordinary grafting is found to succeed better than inarching. (*Paxt. Mag. of Bot.*, October.)
Leguminosæ.

HARDENBERGIA [60.]
digitata Lindl. finger-leaved ♣ □ or 10 ap P Swan River 1839. C s.p.l Bot. reg. 1840,

"A Swan River climber, raised by Mr. Toward, in the garden of H. R. H. the Duchess of Gloucester, at Bagshot. It is clearly distinguished from all the previously discovered species of the genus, by its leaflets growing in fives, and not in threes." In England it forms a free-growing and abundant blossoming green-house climber, with small purple flowers, which it produces in April. "The best soil is loam and peat mixed with a quantity of sand. It strikes readily from cuttings." (*Bot. Reg.*, October.)

CYCLOGYNE Benth. CYCLOGYNE. (*Kyklos*, a circle, *gyme*, a style; style circinately involute at top.)
canescens Benth. hoary ✨ □ or 1 my P Swan River 1839. C r l Paxt. mag. of bot. [vii. p. 199.]

A very handsome betel-like plant, seeds of which were procured by Mr. Lowe from Mr. Drummond, collector at the Swan River. "The species is quite an ornamental one. It has several main stems, around which an indefinite quantity of suckers arise, each bearing a terminal spike of blossoms when not more than a foot high. A rather rich loam, and an airy place in the green-house, are the main things necessary in its treatment." (*Paxt. Mag. of Bot.*, October.)

Rosæcæ.

Spiræa fissa Lindl. A Mexican shrub, sent home by M. Hartweg, who considers it to be "near *S. ariæfolia*." (*B. M. R.*, No. 170, Oct.)

Crassulacæ.

3356. ECHEVERIA 31593 secunda Bot. reg. 1840, 57.

Compósitæ.

2340. CINERA'RIA 21463 lanâta var.

Synonymcs : Senecio Heritièri Dec. var. cyanophthálmus *Hort. Bot. Mag.* 3827.

An exceedingly beautiful plant, which, though it has been long in cultivation, is very little known. It has a small dark blue disk, and a comparatively large white ray. It flowered at Rosemont, near Belfast. (*Bot. Mag.*, Oct.)

+ HYMENO'XYSS *Cass.* (*Hymên*, a membrane, and *oxyss*, sharp; in allusion to the scales of the pappus)
californica *Hook.* Californian \bigcirc pr I s Y California 1838. S co. *Bot. mag.* 3828.

A pretty little annual raised in the Glasnevin Bot. Garden, from Californian seeds; bearing some resemblance in its general appearance to *Lathènia*. (*Bot. Mag.*, October.)

2265. LIATRIS
propinqua *Hook.* related Δ pr 2 s P N. Amer. 1838. D p.1 *Bot. Mag.* 5829.

Nearly allied to *L. spicàta* and *L. hirsùta*. (*Bot. Mag.*, Oct.)

Valeriàneæ.

Valeriàna *Napus* *Lindl.* A Mexican species "with tuberous roots, as large as a full-sized field turnip." (*B. M. R.*, No. 180., Oct.)

Ericàcææ.

1339. RHODODE'NDRON 11012 arbðreum
var. 6 cinnamòdnum subvar. ròseum *Bot. Mag.* 3825.

Epacrídeæ.

+ CYSTA'NTHE *Grah.* (*Kystis*, a bladder, and *anthè*, a flower; bladder-like form of the flower bud)
sprengelioides *Graham* Sprengelia-like \blacksquare cu 3½ ... Y.w Van Diemen's Land 1836. C [s.1 ... *Bot. mag.* 3826.

A "curious shrub discovered by Mr. Brown in Van Diemen's Land;" of no great beauty. (*Bot. Mag.*, Oct.)

Polemoniàcææ.

472. PHLO'X
Coldryana *Hort.* Coldry's Δ \square or 2 ... Dk C hybrid ... D co *Pact. Mag. of Bot.* vii. [p. 197.

A very handsome *Phlóx*, raised some time since by Mr. Coldry, between two species, "of which *P. cordàta* is evidently one." (*Pact. Mag. of Bot.*, October.)

Convolvulàcææ.

BATA'TAS *Choisy.* BATATAS (Malay name)
betàcæ *Lindl.* Beet-like \blacksquare \square or 6 au P.w Demerara 1839. p.1 *Bot. reg.* 1840, 56.

The genus *Batàtas* takes for its type *B. edùlis*, the common sweet potato, and it has been separated from "*Ipomœa* by M. Choisy, principally on account of the ovary being 4-celled, with one seed in each cell, instead of 2-celled, with two seeds in each cell." The present species is very handsome, both in its leaves and flowers; and it has at present been kept in a stove. Dr. Lindley thinks it has probably "sufficient hardiness to succeed in a good greenhouse." It is a native of Demerara, and it was sent to Dr. Lindley by Mr. May of the Ripon Nursery. (*Bot. Reg.*, October.)

Solanàcææ.

591. SOLA'NUM
angustifòlium *Lam.* narrow-leaved \blacksquare \square pr 3 su P Buenos Ayres 1838. C. s.1p Bo- [tanist, No. 190.

An evergreen shrub, with lanceolate leaves, and rather small dingy purple flowers, which are very fragrant. It was raised from seeds collected at Buenos Ayres by Mr. Tweedie, by Mr. Tillery, gardener to the Duke of Portland at Welbeck, who finds that cuttings of it strike readily, and that it thrives in a compost of loam, sand, and peat. (*Botanist*, Oct.)

Solanum macranthum *Moc. et Sesse.* A "beautiful half-hardy herbaceous plant," raised by Mr. Page of Southampton, from Mexican seeds, and having "large clusters of deep purple flowers." (*B. M. R.*, No. 181., Oct.)

Acanthàcææ.

1734. THUNBE'RGIA 15541 Hawtayneàna.
Synonyme : *Meyènia Hawtayneàna* *Nees.*

Prof. Nees von Esenbeck having proposed to separate this species from

Thunbérkia, on account of a slight difference in the anthers, the name has been adopted by Mr. Bentham in the *Botanist*, No. 188. (*Botanist*, Oct.)

Amentáceæ.

Bétula Bhojpúttra *Plant. As. rar.* 2. p. 7., and described in our *Arb. Brit.* p. 1714. as nearly allied to *B. papyræa*, has been raised from Himalayan seeds in the Horticultural Society's Garden. "It will doubtless be perfectly hardy, as, according to Dr. Royle, it, and the other species of that country, occupy the loftiest situations in the mountains." (*Illust.*, p. 343.; *B. M. R.*, No. 169., October.)

Orchidáceæ.

2571. CALA'NTHE 29617 discolor *Bot. Reg.* 1840, 55.

2553. CATTLEYA 31556 Móssiæ Hook.

Synonyme : *C. labiàta* var. *Móssiæ* *Bot. Reg.* 1840, 58.

Dr. Lindley is satisfied that this is a mere variety of *C. labiàta*, "from which it differs principally in the lip being yellow mottled with crimson, instead of deep blood red." (*Bot. Reg.*, Oct.)

+ *Catasètum trùlla* Lindl. The flowers are "green, with a brown stain on the lip," and about thirty in a spike. (*B. M. R.*, No. 176., Oct.)

C. saccàtum Lindl. A very remarkable plant imported by Messrs. Loddiges from Guayana, the flowers of which are furnished with a large conical bag, not perceivable till the lip is turned back. The flowers are very large and handsome, the sepals and petals being covered with rich purple spots, and the lip, which is of a bright yellow, with crimson dots. (*B. M. R.*, No. 179., October.)

C. (Myánthus) cornùtum Lindl. "A native of Demerara, with the habit of *Catasètum barbàtum*, formerly *Myánthus*." The flowers are green, spotted with dark purple, the labellum being "furnished with a strong inflexed white horn," whence the name. (*B. M. R.*, No. 182., Oct.)

C. callòsum Lindl. This plant resembles *C. tridentàtum* var. *floribúndum* in habit, but its flowers are of a dull reddish brown, without spots, with a green lip. "It was imported by Messrs. Loddiges from La Guayra." (*B. M. R.*, No. 183., Oct.)

Cirrhopétalum vaginàtum Lindl. "Messrs. Loddiges have received this plant from Singapore." The flowers are of a pale straw colour, with coriaceous emarginate leaves. (*B. M. R.*, No. 173., Oct.)

Cælogyne Cumíngii Lindl. A Singapore plant, with white and yellow flowers, allied to *C. trinérvis*, which has flowered with Messrs. Loddiges. (*B. M. R.*, No. 178., Oct.)

Comparètia ròsea Lindl. A beautiful little plant with rose-coloured flowers from the Spanish Main. (*B. M. R.*, No. 186., Oct.)

Cymbídium pubèscens Lindl. A Singapore plant, with "a short raceme of rich purple flowers, bordered and spotted with brilliant yellow." (*B. M. R.*, No. 177., Oct.)

Dendròbium vaginàtum Lindl. A Singapore plant, "belonging to the same section as *D. àmplum*," but combining the habit of *Bolbophýllum* with the entire structure of *Dendròbium*. The flowers are of a pale straw colour, tipped with purple. (*B. M. R.*, No. 172., Oct.)

Bolbophýllum limbàtum Lindl. A Singapore plant, the flowers of which are of a dull purple, and of little beauty. (*B. M. R.*, No. 171., Oct.)

Mycaránthes oblìqua Lindl. "A fleshy-leaved plant from Singapore, with very small white flowers, covered slightly with rusty down." (*B. M. R.*, No. 184., Oct.)

Oncídium incúrvum Bark. The scape is paniced, and about 3 ft. long; and the flowers are pink and white. (*B. M. R.*, No. 174., Oct.)

Pleurothállis seriàta Lindl. A native of Rio Janeiro, "with pale yellowish green flowers, marked with rows of purple dots." (*B. M. R.*, No. 175., Oct.)

Sarcánthus pállidus Lindl. An Indian species, with small pale flowers, imported by the Duke of Devonshire. (*B. M. R.*, No. 185., Oct.)

3582. LÆ'LIA

cinnabàrina? *Bate.* cinnabar

£ ☐ spl 1 jn S

Rio Janeiro 1837. O p.r.w

[*Bot.* vii. p. 193.

Pact. mag. of

A most splendid plant, with brilliant scarlet flowers ; remarkable for the great length and attenuated form of its pseudo-bulbs ; which, with the peculiar form of its flowers, made it first considered to be a *Cattlèya*, "till J. Bateman, Esq., upon a closer examination of some flowers unfolded at Knyversly, discovered its proper affinity with *Lælia*." (*Paxton's Mag. of Bot.*, October.)

ART. III. *On a new Method of introducing Palms of large Size into Hot-houses.* By Dr. JOHN LHOTSKY, F.H.S., of Bavaria, &c.

(Read before the Botanical Society of London, Sept. 6. 1839.)

DURING my stay in Vienna, in the year 1829, a plan was laid down by M. Charles Ritter (author of *A Journey to St. Domingo*) and myself, for introducing large palm trees into Europe. It was, in the first instance, based upon the physiological fact, that the fibre, and the bundles of fibres, in these plants are possessed of a high degree of vegetative power, or vitality. If a palm tree, even of a certain age, gets injured at any height of the stem ; for example, its bark being shaved or taken off, the fibre protrudes outside, assumes the appearance and nature of roots, and hangs out from the surface of the trunk. If a palm is cut off below such a beard, as it were, of fibres, and planted, it will very easily grow ; nay, I observed afterwards, in the Brazils, a still more striking proof of this assertion. The *Diplothèmium* is a palm which does not grow more than 18 ft. high. The lower part of its trunk is round and smooth, but the upper square and curiously shaped. The peduncles of the old leaves break off rather long, and remain on the trunk for nearly two thirds of its height. These rudiments of leaves being large, and covered with spines, afford a superior material for forming hedges around plantations ; the tree is cut off a little under this spiny part, planted, and grows very easily.

According to the above plan, I began, in April, 1831, at Bahia, the execution of the commission which had been intrusted to me. Eight different species of palms were collected for that purpose, viz. *Cocos nucifera*, two specimens, with stems 20 ft. long, of about 300 lb. weight each ; *Elæis guineénsis* (Dendé), one specimen, of the same size and weight as the former ; *Attàlia funifera* (Piaçaba), collected 50 miles up the Bay, rather larger in size than the former ; *Attàlia* sp. (Pati), from the same locality, about 18 ft. high, but rather slender, &c.

It is not required, on the present occasion, to state the difficulties which I encountered, having to work with uncultivated negroes, in savage and difficult localities. Several of the palms had a weight of from 300 lb. to 500 lb. It was required to dig out a considerable portion of the roots, without shaking off the earth from the fibres. In some of the palms, for example, in *Cocos nucifera*, the roots extended in a large circumference, say 5 ft. to 7 ft. The outer full-grown leaves were all chopped off, and only the very tender and recent ones were preserved. As soon as I had conveyed the trees home, the remaining rudiments of the leaves were burned with red-hot iron, that the sap might be prevented from oozing through the wounds. For the sake of making this quite secure, they were moreover primed with a composition of hot pitch and tar. As a precautionary measure against cold weather during the sea voyage or afterwards, some cotton was laid around and over the heart, over which, again, a thick layer of flax was properly secured. The palms, thus prepared, were each laid horizontally in boxes, of which the construction was this :— All the planks but those forming the bottom were perforated by large holes ; the lids were adapted to opening, for proper inspection during the passage. At the root end of the boxes, a partition of boards was inserted, merely admitting, through a hole cut for that purpose, the passage of the stem ; and this minor division was, after the trees were

placed, filled up with earth, so as to envelope the roots; this earth was pressed tightly around them, and the captain instructed to sprinkle it every fortnight with water. The instructions further stated, if any mouldiness appeared on the stems, it should be carefully removed by dry cloths. By these, and other contrivances unnecessary to relate, I anticipated that a certain degree of vegetation would continue in these plants, a hope which experience fully realised. The whole plan, in fact, was but a trial, whether or not the vegetation of these tropical trees can be continued while they are in a horizontal position.

The passage from Bahia to Trieste is performed in from 70 to 90 days. But, by an accident which I could not foresee, the vessel (called *Italo*) was obliged to enter the harbour of Gibraltar, where it remained for some considerable time; so much so, that the palms were, on the 1st of November, 1831, still in Trieste. This accident not only protracted the time of their artificial position, but it shifted their arrival to a very unfavourable season, as the month of November is, at times, very cold in Austria. Whatever accidents or improper treatment these palms might have experienced afterwards it is unnecessary to speak of, although, by so doing, I would corroborate the soundness of the plan concocted by M. Ritter and myself. On these plants arriving in Vienna, they were found in a vegetative state, and, according to a letter of M. Rauch* (who then filled a situation in the Imperial Gardens of Vienna), these large trees were, after an unnatural confinement of nearly seven months, still in such a state that one of them pushed out a vigorous leaf.

My endeavours were subsequently appreciated in Prussia; and I have been only lately informed that some gentlemen have been sent from Berlin to Cuba, for the sake of supplying the Royal Gardens with palm trees of a large size.

As I am discussing matter connected with palms, I may just mention that some of their seeds (for example, *Elæïs guineënsis*) have remained, in hot-houses, in the ground for ten years; after which time some of them began to vegetate. It requires certainly a complication of favourable circumstances to soften some of these extraordinarily hard and thick seeds; an operation which is performed in nature by the very wet soil with which the virgin forests of the tropics are covered: but I have been informed that, in some parts of India and China, the people resort to some artificial means of making palm seeds, and others which are very hard, grow easily, viz. by putting them for some time in very wet manure; a contrivance which may be worth attention.

London, August, 1840.

ART. IV. *Facts relative to the Fecundation of Flowers with Pollen which had been kept for some Weeks.* By HAY BROWN, Gardener, Stoke Edith Park, Herefordshire.

THE cactus mentioned to you by Mr. Beaton I raised from *Epiphýllum Jenkinsòni*, impregnated with pollen from *Cereus grandiflorus*, under the following circumstances:—I procured pollen from *Cereus grandiflorus*, folded it up in a piece of letter paper, and, after having carried it in my waistcoat pocket for several days, I laid it upon the chimney-piece in my kitchen till I should have an opportunity of trying it: this happened in the course of 5 or 6 weeks afterwards, by my having a plant of *E. Jenkinsòni* in flower, which I impregnated with the above pollen, and the result was the seedling alluded to. It may be superfluous to say that the pollen was as dry as possible, and not very tenderly used; but it may be necessary to state that no other of the family were in flower at the time, and the flower was opened with care, and the anthers removed before they burst.

* M. Rauch is now an able assistant of Mr. Loudon in laying out grounds, and a contributor to the *Gardener's Magazine*, &c.

Having often tried, and as often failed, to obtain a cross from *C. grandiflorus*, it seemed to me that it might be from the short time the flower remained open, or the close situation in which it flowered, or both, that the pollen never got matured or dry enough to generate; and this made me anxious to try what dry pollen would do.

The year following, I impregnated *Rhododéndron arbóreum* (which was flowering in the same pine stove) with dry pollen taken from a fine variety which was flowering in the green-house at Belmont, 11 miles hence; and the result was (after marking the crossed flowers), that all those which were impregnated set and matured their seed, and all the other flowers dropped off; not one stood; and the seedlings they produced are more in the habit of the male than that of the female parent.

From the above, I think it probable that dry pollen, under some circumstances, and with some genera of plants, may produce in crossing more distinct varieties than pollen immediately taken from the one plant to the other.

Stoke Edith Gardens, Aug. 18. 1840.

ART. V. *On the Shriveling of Grapes.* By W. H.

SEVERAL articles have appeared at different times in the *Gardener's Magazine* on the shriveling of grapes. I have tried every one of them as they made their appearance, but without the least success. In Dr. Lindley's *Theory of Horticulture*, article Bottom Heat, it is there stated that the cause is, that the roots being in a colder medium than the branches, the supply of sap is consumed quicker than the roots can furnish it, and this brings on the disease. Dr. Lindley, every one must allow, is very high authority, still I doubt this being the cause of the blacking of the footstalks, which is the disease that I particularly wish to refer to. I have the management of three houses in which grapes are grown. One I begin forcing the 1st of January, one the 1st of February, and one the 1st of March. The first house ripens its fruit in May, the second in June, and the third in July. In the first and second there shall be no shriveled berries; in the third, if the weather is cloudy, there shall be a great many. The covering is taken off the borders about the beginning of April, and if the coldness of the borders was the cause, I should suppose that those which ripened in May and June would be more subject to the disease than the July one, for the earth undoubtedly gets warmer as the summer advances. I have been a grape-grower for more than twenty years, and during that time this disease has particularly engaged my attention, as I have always been more or less subject to it, and I am fully convinced that it is caused by the borders being made too rich and stimulating, and by a deficiency of light. My borders are all prepared in the same way, and of the richest materials, and the one that I commence forcing in March produces foliage of the most luxuriant description; those large leaves require more light to elaborate the sap than smaller ones, and if light is deficient, the sap is not properly prepared for the healthy nou-

ishment of the fruit, and this brings on the disease. I have known vineries where borders have been made inside of the house, and vines planted against the back wall, and borders made outside, and vines trained up the rafters. The grapes upon the back wall have every one of them shriveled until the vines upon the rafters had been shortened so as to admit the light upon the back wall, and then the grapes have done well, plainly proving that want of light was the cause, and not the want of heat in the border. In early forcing I have covered one half of the border with hot dung and leaves 2 ft. thick, the other half 6 in., and I never could discover the least difference in the growth of the vines inside or in the fruit. The larger the leaves are the more light they require to assimilate and decompose the sap; and this, in my opinion, is the reason why early forced vines do not shrivel, their leaves scarcely ever being more than half the size of those begun in March, and the light in May and June is commonly greater than that of July, which is in general a dull and showery month. After trying every thing that I had seen recommended as a remedy, and feeling fully convinced in my own mind that want of light was one of the causes, I thought I would try what effect proportioning the heat to the light would do. This I have practised for several years, and with a success beyond my expectation.

In dull weather I keep the house cool, and when the grapes begin to colour, if the weather is warm, I leave the top and front lights a little open, so as to keep up a regular circulation of air in the house night and day; and, if the weather is cold and wet, I shut the front lights, and a little fire is made in the front flue so as to cause the air to circulate, but nothing like forcing is attempted. By this simple mode of management, I have so far conquered the disease, that instead of losing half the bunches, I now only lose a few berries here and there in some of the bunches, and a few at the points of some of them, but not any of any consequence. I have lost more this year than I have lost for years, but this has been the worst July for forcing that ever I experienced. I never expect to get entirely rid of it, as the great fault lies in the formation of the border.

We consider the vine to be a gross feeder, and therefore think that it is impossible to make the borders too rich, but this is certainly a great error. It is true they grow with great vigour, and soon get to the top of the house when planted in a large mass of rich soil, but this is small compensation for the gross and diseased habit which remains with them as long as they live.

Moseley Hall, Aug. 10. 1840.

REVIEWS.

ART. I. *The Eastern Arboretum, or Rural Register of all the remarkable Trees, Seats, Gardens, &c., in the County of Norfolk.* By James Grigor. Illustrated by drawings of trees, etched on copper, by H. Ninham. Nos. II., III., and IV. 8vo, 9 plates. London; July, August, and September, 1840. 1s. each.

THE first number of this most agreeable and entertaining work is noticed in p. 352., and we have great pleasure in stating that it increases in interest as it proceeds. Like Mr. Grigor, we have a regard for trees, "because they grew in Paradise, because they are employed in Scripture illustration, and because we find them about our homes, old and trusty companions,—the earliest objects that memory fixes upon."

Trees and Gardens of Norwich, continued.—The best collection of *Craægus* in Norwich is in the garden of S. Brignold, Esq., where there is a common hawthorn 50 ft. high, and an elm $10\frac{1}{2}$ ft. in circumference, and 85 ft. high. *Quercus Cériss*, in the garden of A. Taylor, Esq., has, in 23 years, attained the height of 35 ft., with a trunk $4\frac{1}{2}$ ft. in circumference. A medlar, in the garden of C. W. Unthank, Esq., measures $4\frac{1}{2}$ ft. in circumference. *Fagus sylvática*, in the garden of Mrs. Jane Gurney, measures 12 ft. in circumference. A snowdrop tree, *Halèsia tetráptera*, of which an engraving is given, is 29 ft. high, with a trunk 4 ft. in circumference, and the diameter of the space covered by its branches 33 ft. We should think this must be the largest specimen of snowdrop tree in England. It stands in the grounds of a villa called the Town Close. "Beside this object, there is a handsome specimen of the tulip tree (*Liriodendron Tulipifera*), measuring $6\frac{1}{2}$ ft. in circumference, and 50 ft. in height,—a favourite with botanists, on account of its conspicuous flowers. But the great charm of this heavenly retreat is a shaded walk o beech, a verdant arcade of 90 yards in length, forming a promenade almost unequalled except in fiction. It looks like a relic of fairy land. At the entrance to this seat, on the Newmarket road, there are two elms of the Wych or Scotch species (*Ulmus montana*), which are really worthy of attention. In our estimation, the elm is one of the most dignified objects in our sylvia. It is this tree especially that flings an air of solemn magnificence around the habitations of men, and strikes the beholder with ideas of more ancient grandeur than is conveyed to him by the consideration of long-worn titles and orders. It would appear that similar ideas have been held by the most of mankind; for it is almost universally found close to our old family mansions and baronial towers." *Arbutus U'nedo* is 20 ft. high, in the garden of F. Ives, Esq. The residence of R. Merry, Esq., the most romantic seat about Norwich, contains many young trees in a highly vigorous state, though none deserving of particular remark, either as to their size or rareness.

"Mrs. Martineau's residence, at Bracondale, presents us with a perfect picture of an extensive and beautifully secluded seat, abounding in all the characteristics of our old English mansions, and may be said to be the only retreat in the immediate neighbourhood of Norwich that partakes of the beauties of our finest lordly demesnes. Amidst the solitary bowers of this suburban sanctuary, there are several temples, a priory, and hermitage interspersed, commanding delightful glimpses of the surrounding country. The principal trees we observed were the broad-leaved English elms, some of them measuring from 11 ft. to 12 ft. in circumference." *Magnòlia grandiflòra* has a trunk 2 ft. in girth on the lawn of George Morse, Esq., Catton.

"Earlham Hall, the residence of Joseph John Gurney, Esq., appears to be one of the most ancient seats in our suburbs, full of sylvan magnificence. It contains a heronry—that noble appendage which nature is so shy of

bestowing. When trees get old, and are resorted to by birds generally, as is the case here, it is a sure sign that their effect in landscape is complete (for the feathered tribes are the best of all judges in this respect): they enter then upon the reverential class, and give a consecrating touch to every thing around them. It is on this account that such of our old family mansions and castellated halls, that are so embosomed amongst trees, read to us so much of descent, and lead back the mind to some of the best and brightest days of hoary antiquity. The extraordinary trees in this park, which deserve particularly to be noticed, are of the English oak. The largest of those we measured has a trunk 24 ft. in girth; but it is divided into two large limbs a few feet from the ground, which considerably destroys its appearance. The handsome tree of this species, so well known to all those in the neighbourhood who take an interest in those matters, is of less magnitude, measuring 19 ft. in circumference, whilst that of the space overspread by the branches is 152 yards."

Cossey Park, the Seat of Lord Stafford, is described, and justice done to the architecture of the mansion, and the extensive and well-stocked walls of the kitchen-garden, "the whole arrangements of which bespeak the enlightened management of Mr. Wighton the gardener. The trees here of most note are ashes, with trunks from 4 ft. to 6 ft. in diameter; a large elm, of which an engraving is given; and old thorns, with trunks which girt above 3 ft. We thank God for his trees, and the green sod He has laid out around them! They are his gifts; and we look upon them as so many invitations to us to be good men. And though He cursed the earth generally, with all its fair furniture, we see that he hath withheld the severity of the sentence from some spots; for they yet break into loveliness, and assume all we fancy of primeval verdure. Such a spot is *Cossey*."

Dereham and its Neighbourhood.—"We hasten to remind our readers at a distance, that we write these lines at the grave of the inimitable poet, Cowper. The good man sleeps on the breast of a sunny bank in one of the richest spots of rural Norfolk, amid much of the quiet and inviting traits of nature. There are trees about his grave; and we are now convinced more than ever, that there ought to be no cemetery without them; for otherwise you cannot get birds to come and sing around those sacred places; and besides, in their absence, churchyards never assume that settled quietude which all of us associate with the picture of what we should like our last earthly resting place to be; they wear rather an aspect of awful desertion, as if in the midst of a moor or common, where nature is unchanging."

"The trees which overshadow the place where this great man reposes are of the *Acer Pseudo-Platanus*, our English sycamore, or the plane of the Scotch, distinguished by some old people as a Bible or New Testament tree, being that from which Zaccheus saw our Saviour whilst on his way to Jerusalem, and the same species which to this day skirts the hallowed shores of Genesareth." Mr. Grigor has here fallen into a little mistake, the sycamore of Scripture being the *Ficus Sycómorus* of Linnæus, a native of Egypt and of the Holy Land. "In the neighbourhood of Dereham are the extensive lawn and gardens of W. W. Lee Warner, Esq., containing some of the most vigorous and handsome trees in the county. Those who are not generous enough to provide for posterity may find a proof here that it is possible to enjoy the fruit of one's own hands; for, with a few trifling exceptions, all the trees on this well-wooded park were planted by the spirited proprietor himself. One of them, an English elm, already measures 2 ft. in diameter, and rises to the height of 50 ft. We are at all times particularly delighted to see the first gentlemen of our land thus betaking themselves to the 'heroic line of husbandry,' and rearing both for themselves and successors such useful and endearing objects."

(To be continued.)

ART. II. *The Florist's Journal.* In 8vo Numbers, monthly, with 1 coloured plate to each Number. Nos. I. to VII., pp. 168, each Number containing a sheet and a half. London, 1840. 6d. each.

THIS work is understood to be edited by Mr. Mudie, which is a guarantee for the correctness of the language, eloquence when he writes himself, and for sound sense in regard to general opinions either of himself or of others. Among the names of the contributors, we observe Mr. Main, Mr. Henchman, Mr. Don, Mr. Plant, Mr. Groom, Mr. Ansell, Mr. Green, and Mr. Gaines. The work, to use a technical phrase, is remarkably well got up, in regard to paper, print, and the coloured plates, and, without making any invidious comparisons, we certainly think it better deserving of patronage than some other magazines of the same kind sold at the same price. It is something to be able to take up a gardening book with the foreknowledge that in reading it we shall not be offended by vulgarity or obscurity of language, or by local or technical terms not generally understood; and though a work thus purified may not be filled with papers by practical men, and, therefore, not always very suitable for the gardener, it is unquestionably the most suitable for the amateur. We shall now take a glance at the numbers before us.

In No. I., there is an eloquent introduction, showing the pleasures and advantages of cultivating flowers in a moral point of view, and noticing the "principle according to which flowers are improved by cultivation. The principle is this. Our power of improving flowers, that is, of breaking them from those characters which they have in wild nature, depends in no small degree upon the difference of the circumstances in which they grow naturally, and those in which we rear and train them artificially. It is true that some plants will bear only a limited change, while others admit of change to a very great extent; but, notwithstanding this, it is a general law in floriculture, that the more different treatment it can bear from that which nature gives it, the more it may be improved by the cultivator. There is also another general principle: — Plants, including flowers, evergreens, and all others, of what description soever they may be, can bear much better to be transported from warm latitudes and situations to cold, than from cold to warm." We might notice some trifling mistakes in the first number, such as wild hyacinth for Oriental hyacinth in p. 8., misspelt botanic names in p. 19 and 20., and other places; but such errors will doubtless be avoided in future numbers.

No. II. contains an article entitled "Colours of Flowers and their Contrasts," in which a right view is taken of the subject, viz., that "the arrangement of flowers will be best in which colours and their complements are brought together, because in this case each will, from the nature of the eye, impart lustre to the other." (p. 28.)

In a paper on Tulips, by Mr. Groom, in No. III., he states that "the shape of the cup of the flower, when fully expanded, should be a semi-oblate spheroid (or the half of a somewhat flattened globe), the stalk being inserted in the pole, which pole should be a little depressed." This Mr. Groom considers the best form to retain the beauty of the flower during all its stages. "The petals," he says, "should be all level on the top, and not the three outer ones turning back from the others, nor the inner higher than the outer. The ground, by which is meant the white or yellow on which the other colours are marked, should be pure and rich, without spots or stains; and it is of the greatest importance to have it quite clear of any colour or marks at the base of the petals round the stamens, for a stain there is a permanent defect which no cultivation can remedy." (p. 56.) An article on the Selanthi, or flowering plants with the organisation apparent, though still different from the flowering plants properly

so called, would have been better understood if it had been accompanied by names and definitions of the other grand divisions of the vegetable kingdom, and also by a list of genera and species. We speak with a view to practical men, for whom we presume the work is intended, as well as for amateurs.

No. V. contains an article "On the Practicability of causing Shrubs to flower twice in the growing Season." The principle laid down is, "that a plant checked in its career of growth, especially in developing its reproductive members, makes a second, and sometimes even a third, attempt the same season, to complete the final object of its growth, the production of flowers and seeds." Hence if the first buds or shoots of a shrub or tree be rubbed off, or the first flower stems of a herbaceous plant removed as soon as they have made their appearance, second buds and stems will be produced immediately afterwards. Removing the trees or herbaceous plants later in the season than usual will cause them to flower later than usual. In general, roses and all flowering shrubs may be made to flower twice the same season, by pruning back the young shoots that have already flowered, and supplying the plant copiously with water for a week or two till it has again pushed. In an article "On Change of Air and Soil," it is said to have "been proved that seeds or plants removed from one soil to another of exactly the same description, but at some distance from each other, either longitudinally or in different parallels of latitude, not too far from the middle of the temperate zone, become renovated, and advance with more celerity than if they had not been transplanted." (p. 106.)

In No. VI., the editor informs his readers that he has "insured the assistance of Mr. Don, brother to the Professor of Botany in King's College," to furnish from time to time authentic accounts of the management of the Orchidaceæ, and other choice plants of tropical climates; and he trusts that with such a cooperator, having so splendid a collection under his immediate care, he shall be able to make his journal without a rival in this department. (p. 154.)

An article entitled "Visits to Nurseries," by the conductor, runs through several numbers, and in Nos. IV., V., and VI. Kew Gardens and Dr. Lindley's report on them are noticed with some degree of acerbity; at the same time, there is much wholesome truth in the article, which we trust will receive the attention of government. We are glad to find Mr. Mudie doing justice to the merits of Mr. Smith. The sum required to put and keep the establishment of Kew Gardens on the most respectable footing is, according to the editor, not more than 4000*l.* or 5000*l.* a year; Mr. Smith, we believe, is also of this opinion. "Many objects, which conduce neither to glory nor gain, and the want of which would be no disgrace or loss, cost far more than this, only they are taken up by parties who are in real earnest in their attempts to accomplish them." (p. 129.) The mere circumstance of this magazine being conducted by Mr. Mudie ought to insure for it the public patronage.

ART. III. *The Floricultural Magazine and Miscellany of Botany.*

Edited by Robert Marnock. No. 53. for October. 8vo, 1 coloured plate, a sheet and a half. London, 1840. Price 6*d.*

THIS number has been sent to us, we presume, on account of the following announcement:—

"The most elegant and cheapest Floricultural Periodical published."

"Arrangements have been made by which a very considerable improvement will be effected in the general appearance of this magazine. The plates will be executed by first-rate London artists, and will present more correct

representations of the flowers, which will be coloured faithfully after nature ; and the printing department will also be executed with greater care than of late."

The paper and print in this October number are certainly better than they have hitherto been, and the figure of *Ipomœa Learü* is good, and certainly of greater artistical merit than any of those in the *Florist's Journal*, though these are an immense deal better than even the figures in *Paxton's Magazine* were at the commencement of that work. With respect to the articles in the *Floricultural Magazine*, they will be liked better by the practical gardener than those in the *Florist's Journal*, but not so well by the lover of speculative science, and of vigorous, eloquent, and correct language. Both works we hold to be essential, as well to the young gardener as to the amateur.

ART. IV. *Organic Chemistry in its Application to Agriculture and Physiology.* By Justus Liebig, M.D. Ph.D. F.R.S., &c., edited from the manuscript of the author by Lyon Playfair, Ph.D. 8vo, pp. 387. London, 1840.

THOUGH we have received this work too late in the month, yet we consider it of so much importance as to deserve an interim notice.

Part I. treats of the chemical processes in the nutrition of vegetables, p. 1. to 211., from which we give the following extract :—

"*The Art of Culture.*—The conditions necessary for the life of all vegetables have been considered in the preceding part of the work. Carbonic acid, ammonia, and water yield elements for all the organs of plants. Certain inorganic substances, salts, and metallic oxides, serve peculiar functions in their organism, and many of them must be viewed as essential constituents of particular parts.

"The atmosphere and the soil offer the same kind of nourishment to the leaves and roots. The former contains a comparatively inexhaustible supply of carbonic acid and ammonia ; the latter, by means of its humus, generates constantly fresh carbonic acid, whilst, during the winter, rain and snow introduce into the soil a quantity of ammonia, sufficient for the development of the leaves and blossoms.

"The complete, or, it may be said, the absolute, insolubility in cold water of vegetable matter in progress of decay (humus), appears, on closer consideration, to be a most wise arrangement of nature. For, if humus possessed even a smaller degree of solubility than that ascribed to the substance called humic acid, it must be dissolved by rain water. Thus, the yearly irrigation of meadows, which lasts for several weeks, would remove a great part of it from the ground, and a heavy and continued rain would impoverish the soil. But it is soluble only when combined with oxygen ; it can be taken up by water, therefore, only as carbonic acid.

"When kept in a dry place, humus may be preserved for centuries, but when moistened with water, it converts the surrounding oxygen into carbonic acid. As soon as the action of the air ceases, that is, as soon as it is deprived of oxygen, the humus suffers no further change. Its decay proceeds only when plants grow in the soil containing it ; for they absorb by their roots the carbonic acid as it is formed. The soil receives again from living plants the carbonaceous matter it thus loses, so that the proportion of humus in it does not decrease." (p. 117.)

Part II. p. 217., to the end of the volume, treats of the chemical processes of fermentation, decay, and putrefaction.

Our readers will thus be enabled to form an idea of the contents of the work, and of the manner in which the author treats his subjects, and, we think, they will agree with us, that it promises to be one of the most instructive books for the scientific cultivator and the agriculturist, that has appeared since the time of Sir Humphry Davy's *Agricultural Chemistry*.

ART. V. *William May's Priced Catalogue of select Plants grown in the Hope Nursery, Leeming Lane, Bedale, Yorkshire.*

THIS selection appears to us extraordinary for a provincial nursery in a remote part of the country. It contains, stove plants, 80 kinds; cacti, 50 kinds; green-house plants, 340 kinds; pelargoniums, 50 kinds; calceolarias, 80 kinds; camellias, 84 kinds; ericas, 90 kinds; select and showy hardy herbaceous plants, 370 kinds; heart's ease, 120 kinds; auriculas, 96 kinds; select polyanthus, 22 kinds; carnations, 108 kinds; pinks, 96 kinds; roses, 408 kinds; select and showy hardy shrubs and ornamental trees, 306 kinds. There is nothing fills our minds with ideas of the riches and grandeur of England so much as the institutions and establishments, private and public, of the provinces. The capital cities of other countries may rival London, Edinburgh, and Dublin; but where is the country in which every description of wealth, industry, and taste is so universally spread over its surface, as it is in Great Britain? The progress also of this diffusion of intellect and industry is most remarkable. Twenty years ago, and half the articles contained in this catalogue could not have been obtained in any metropolitan collection. We may observe of this catalogue, that the retail prices to each plant are printed, which prevents the risk of those mistakes which sometimes occur, when the prices are written in with the pen. A few of the names are misspelt, and others are evidently local or erroneous names; for example, *Arbutus americana*, *Berberis ovalis*, *B. ártica*, *Cratægus obcordata*, (*C. mexicana* and *C. Lamberti* are made distinct, but they are both the same,) *Pýrus polyvèria* should be *P. Bolwylleriána*, *Deutzia undulàta*, *Labúrnum bullàta*, &c. We wish every nurseryman would get into the habit of putting authorities after his scientific names; and also of making certain that his names are correct, by comparing his plants (by specimens or otherwise) with those of some nursery or botanic garden where the names are acknowledged to be so. For example, with the collection in the Fulham Nursery, or with the Derby Arboretum. Since writing the above, we have received various specimens from Mr. May, and sent him their correct names. *Arbutus americana* is *Arctostáphylos Uva úrsi*; *Berberis ovalis* and *B. ártica*, the common berberry, or very slight varieties of it. *Cratægus obcordata* is the common hawthorn; *Deutzia undulàta* is *D. corymbòsa*. A great many specimens sent us by Mr. May were correctly named, from which we augur well of his general correctness.

ART. VI. *Design for laying out the Inner Circle of the Regent's Park as a Garden for the Royal Botanic Society of London.*

Referred to in the Report of Messrs. Burton and Marnock, dated July 15. 1840.

WE gave a large extract from the *Report* referred to in a preceding Number, p. 514., and there anticipated being soon able to give some account of the plan; a lithographed copy of that plan is now before us. It certainly does not look very promising on paper, from the obvious want of harmony resulting from the large (chiefly) rectangular mass of hot-houses placed so conspicuously in a circular plan, and occupying so large a proportion of the area; but that, and other appearances, on paper, which might be objected to, will disappear in the execution, and more especially after the trees have been a few years planted. One part of the details of the plan we would suggest might be altered with advantage; it is the shapeless beds marked R R "for choice flowers," on the left margin of a walk leading from the piece of water to the terrace. Circles of different sizes grouped together would be incomparably better in point of effect, and even more convenient for culture; for every circle might be confined to one genus, species, or variety of plant. On pointing out these beds to a gardener of good taste and objecting to them, he

informed us that such beds were common in the Sheffield Botanic Garden, along the central walk. If they are, we can only say that we do not recollect to have seen them, the only time we were in that garden, viz. in May, 1839, otherwise we should have made the same objections to them which we do now. We recollect the angular outlines of the clumps in which the trees were planted, and have described them in our volume for 1839, p. 454., as having been introduced by Mr. Marnock for a particular purpose. At the junction of walks, the angles of buildings, and in some other situations, shapes of beds called forth by the existing lines are advisable, but on a lawn, or along a gently winding walk where there is nothing to indicate any particular form, circles will almost always be found the best forms that can be adopted. When properly grouped together, they vary, like single trees and small groups, with every position of the spectator; and, whether they are planted with shrubs or with herbaceous plants, they are more likely to be covered by vegetation than any description of angular, and especially acute angular, forms. The reader may refer to what we have said on the subject on former occasions, and more particularly at p. 582. and p. 589. in the present volume. The adoption of circles in the plan referred to in the Report will occasion no change in its main features, and no extra expense whatever.

We can easily conceive that the hot-houses are placed on one side for ready access to them from the street, as a winter garden, in the winter season; otherwise most effect would have been produced by placing them in or near the centre, and surrounding them with a zone of gravelled terrace, and beyond that with an extensive zone of lawn for promenade. We make these remarks with the most perfect good feeling to all concerned, and sincerely desire that this design may be carried into execution.

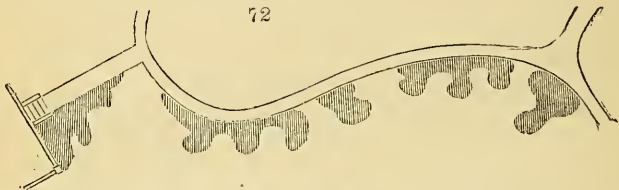

Fig. 72. shows the intended flower-beds as indicated in the plan; and fig. 73. shows circular beds placed in the same situations as the others, and which, it is believed, would have a very superior effect.



ART. VII. *Religion and Crime; or the Distresses of the People, and the Remedies.* By John Minter Morgan. Third edition, enlarged. 8vo, pp. 78. London, 1840.

"I AM delighted with the account of the Derby Arboretum. Surely the government must soon do something for the recreation of our poor working classes, and not leave it to private charity. Have you read *Religion and Crime*, by Morgan. If not, get it immediately, for it is the most cheering and delightful thing I ever perused. I laughed for joy, while I was reading it, to

think on what is in store for a future generation of the working classes, but ultimately wept when I thought on their present state." The above extract from a letter received from an extensive landed proprietor in the Highlands of Scotland, well known for his active benevolence and the ameliorations which he has introduced on his estates, induced us to glance at Mr. Morgan's work, and though, from having perused most of Mr. Morgan's other works, we were aware of the general nature of its contents, yet we were gratified in a very high degree by the details. The author, as remarkable for benevolence as for the peculiar elegance of his mind, examines the subject of spiritual, intellectual, and physical improvement, and under the latter he treats of churches, schools, and dwellings. Houses for the poor are recommended to be built in squares, with all the various adjuncts mentioned in our *Encyclopædia of Cottage Architecture*, p. 244. Societies of young men for the promotion of moral reform, on the principle of those established at New York and other towns in America, are recommended to be formed, and the rules and objects of the American Societies given. The *declaration* to be signed is as follows, and we most ardently wish that every head gardener would get such a declaration signed by the young men under him, and every country gentleman by his indoor servants.

"We, whose names are subscribed, believing that *licentious conversation*, by unnaturally exciting the passions, and familiarising the mind with vice, is the worst enemy to morality, and that some measures for effecting a reformation are highly necessary, do voluntarily agree to abstain from all such conversation, and to discountenance it in others." (p. 44.)

After discussing various schemes of education and moral and physical improvement, the author thus concludes, "When it is recollected that His Royal Highness the late Duke of Kent devoted great attention to plans similar in principle to those now recommended, it may be presumed that the Queen would derive peculiar pleasure in advancing those truly Christian measures which her royal parent, the illustrious patron of benevolent institutions, with so much kind condescension and ability commenced. . . . It would be an act of royal grace and favour, inestimably dear; . . . and, while it is calculated to promote the industry, health, comfort, intelligence, and morals of the people, will conduce, under the blessing of Almighty God, in an eminent degree, to advance their spiritual improvement." Unhappily for the fulfilment of these wishes, Her Majesty is only Queen.

ART. VIII. *Literary Notices.*

The Farmer's Almanac, and Calendar, for 1841; by Cuthbert W. Johnson, Esq., and William Shaw, Esq.; will appear in November.

The Lady's Magazine of Gardening, by Mrs. Loudon; No. I. with coloured plates, to be published by Smith, Fleet Street, will appear on the 1st of January, 1841.

The Gardener's Annual Register; containing an epitome of the improvements in garden and agricultural botany, rural architecture, and in horticulture, floriculture, arboriculture, and landscape-gardening, made during the year 1840; will appear on the 1st of January, 1841.

MISCELLANEOUS INTELLIGENCE.

ART. I. *General Notices.*

EXPERIMENTS with a Liquid obtained from Bones.—I have tried one or two experiments with the bottle of liquid obtained from a distillation of bones, which you sent me. It would have been first highly desirable to have ascertained its properties by chemical means. In the absence of this inform-

ation, you may be pleased to know the effect it had on one or two plants. I considered, from the appearances produced, that it contained a considerable portion of muriate of ammonia and phosphate of lime, held in solution by some acid. I first applied it to a plant of *Geissomèria longifolia* infested with the mealy bug. The leaves were wetted with the liquid by a brush, and in a few minutes its deadly effects were visible. The parts touched with the liquid appeared as if they had been anointed with sulphuric acid, and betrayed at once its highly caustic properties; the bugs, of course, fell a prey to its causticity, as well as every part of the plant with which it came in contact. It did not, however, kill the plant. I administered a little at the root of one or two succession pine plants, and it very soon evinced its stimulating effects, by starting them into fruit. I also poured a little in the pots of two plants in fruit; but I could not distinguish any apparent result, although, probably, had it been continued in a diluted state, it might have proved beneficial. The quantity I possessed would not permit me to extend my liberality farther.

The experiment on the *Státice arborea* was in effect the most singular. I had two plants of this species of *Státice*, as near as possible alike in size and health, which enabled me to discover any visible difference. I therefore poured a little of the distilled liquid on the surface of the earth in one of the pots; and, that its effects might be felt some way down the soil in the pot, I poured some water immediately over it, to assist in washing it down to the roots. In four or five hours the vigour of the plant seemed paralysed, and in a day or two the leaves began to assume a reddish brown freckled hue. It then became interesting to know whether the spongelets had absorbed any portion of the liquid to produce this singular mutation, or if the appearance were caused by the roots having sustained injury from the liquid. The leaf sent will convince you that the former inference is correct, for I can detect both appearance and smell; but you can draw your own conclusions. [The leaf was withered before we received it, and we could not detect any smell.] There is one decided objection to its use in the present state in hot-houses, the smell is unbearable. This may be owing to the ammoniacal gas evolved in the heated atmosphere of a hot-house; whether any admixture would destroy this, your chemical friends must inform you; my opinion is, from the appearance of the soil after its application, that it must prove highly fertilising. We have therefore to learn the best manner of using it: probably, in combination with some other substance, its chemical properties might be changed, and all its nutritive qualities retained. As you say it can be procured cheap, it would be worth while to try its effects, both as an agricultural and horticultural manure, by mixing given quantities in heaps of compost in preparation, and trying it in the culture of the pine and the melon, &c., on the potato and the cereal grasses. This might prove interesting to some of your friends who have leisure and opportunity, and eventually confer a lasting benefit on the interests of gardening and agriculture.—*R. Glendinning. Bicton Gardens, August 19. 1840.*

Musa superba Rox. Coromandel, t. 223., flowered in the Botanic Garden at Calcutta, 33 months after the seeds from which it sprang were sown; but in the Edinburgh Botanic Garden this species blossomed in the end of August, 1840, 14 months after the seed from which it sprang was put into the ground. Every one, Professor Graham observes, who has visited the Botanic Garden for some years past, has been struck with the brilliant success which has attended the cultivation of the many forms of banana, under the judicious management of Mr. M'Nab, and the great quantity of high-flavoured fruit which has been produced; but nothing has offered a greater triumph than the rapid perfection of this beautiful species from imported seed; though we learn from Dr. Roxburgh that it does not yield a fruit which can be eaten, but one which resembles a dry capsule rather than a berry. We learn from the same authority, that it is a native of the valley in the southern part of the peninsula of India. In cultivation in the Botanic Garden, this and all the varieties of fruit-bearing bananas have been planted in large tubs containing extremely rich soil, have had much water, and been kept in

great heat. The flower bud, as I have proved by cutting down full-grown plants of *Musa rosacea* and *M. Cavendishii*, and I think also of *M. paradisiaca*, remains at the root till a time after the plant has attained its full size, varying according to its treatment, and then pushes its way upwards; its appearance at the top of the stem being preceded by the evolution of one or more leaves smaller than the rest. (*Edinburgh Phil. Journ.*, October, 1840, p. 386.)

New Fuchsias raised by W. May, Leeming Lane, Bedale.—*F. multiflora erecta*, *F. pendula terminalis*, *F. fulgida superba*, *F. floribunda magna*, *F. longifolia elegans*, *F. grandiflora maxima*, *F. stylosa conspicua*. — *Cond.*

The Pommerail Pine-apple is superior to all others in our cultivation, for the size and flavour of its fruit. It is sold by the Parisian pine-growers at from 25 to 30 francs a plant.—*W. Gordon, Gardener to the English Ambassador, 39. Rue de Faubourg St. Honoré, Paris.*

The Swainston Seedling Strawberry was raised at Swainston in the Isle of Wight in 1838, and promises to be a very valuable variety. The foliage is large, somewhat resembling that of Keen's seedling, and the fruit is also large, and produced in extraordinary numbers during the whole summer. In shape the fruit resembles that of the Alpine, but it is three or four times larger. The scapes are much branched, and contain many fruit, and even blossoms, in all the different states, from the opening blossom to the mature fruit at the same time. We have seen specimens brought from the Isle of Wight by Mr. Forrest of the Kensington Nursery, in the first week of October, with many ripe fruit, and others in different stages, and also blossoms, as above mentioned. The flavour is said to be good, and the culture that of the common kind. — *Cond.*

Dry Rot.—A solution of muriate of zinc has been found by Sir W. Burnett to be equally effective in preserving timber, cloth, ropes, &c., as Kyan's preparation of mercury, while it is a great deal cheaper. A patent has been taken out to secure this valuable invention, and specimens of articles preserved by it during a year in one of the dampest cellars in Somerset House, were exhibited before the Society of Art in Edinburgh, on February 26. 1840. (*Jam. Jour.*, Oct. 1840. p. 401.)

Supplying packed Plants with Water during long Voyages.—Mr. Knight, of the Exotic Nursery, has found that a slowly leaking porous earthen vessel, placed in the centre of the box or bundle, or two or more of them, if the package should be large, will supply as much water as can be wanted during the longest voyage. — *Cond.*

ART. II. Domestic Notices.

ENGLAND.

CANNABIS sativa var. gigantea.—You may, perhaps, recollect, that in the spring of 1839 you favoured me with some seeds, of the progress of which I will now render an account. The first was *Cannabis sativa var. gigantea* from Siberia: several of these seeds had been bruised in the journey, and none of them vegetated. — *Linum* sp. was the next, and was said to be of great height, from Siberia; this vegetated and grew freely, but the rabbits laid such close siege to it, that they destroyed all the plants except two or three, which I took up in the autumn, and potted; and as the vermin had not permitted them yet to flower, they survived the winter, and have this summer perfected a few capsules of seed, sufficient to reproduce the species, and I hope to be more fortunate with them next year. — *Melilotus* sp., from Bokhara, was the next species, and was said to attain the height of 13 ft. in its native country. I sowed it on the 6th of April, 1839, very thinly in drills, interlining drills of Himalayan barley, on a strong sandy loam of the old red sandstone, deeply trenched. The seed freely vegetated, and rose, in the course of the autumn, to the height of 3 ft., exhibiting a few florets on the strongest plants, and ripening about an ounce of seed. In the present year, the crop rose to

a great height, and although much broken down and prostrated by a violent storm in August, yet I have been able to select an unbroken stem, which measures 10 ft. in length ; many of the stalks are, at the base, of the size of a man's forefinger, hollow, but very woody and strong. I am not yet able to ascertain whether the plant will prove a perennial or only a biennial. The produce of seed is immense. The quantity you sent me might have been contained in a dessert spoon. From this year's produce of that small stock, I have already, this autumn, sown about two gallons of seed ; and when I have harvested and rubbed out the residue, I expect about half as much more, which I shall not sow till spring. The application of this crop must, as it appears to me, be in a degree limited. I conceive that, when somewhat less than half-grown, it might be cut for green fodder, and possibly for hay ; but the great size of its stalks would create a difficulty in getting it sufficiently dried for hay, within the compass of any ordinary haymaking season. If suffered to stand till it has attained its full stature, though it would, in that state, be somewhat less succulent, yet its great bulk would render the drying of it a very slow and uncertain operation. If dried, I believe that, with the aid of a powerful chaff-cutter, it might be brought into a state which would render it practicable and palatable to horses ; a stock that always relishes, and even requires, a certain portion of ligneous matter in their food, to keep them in health ; and would be a wholesome accompaniment and corrective to Swedish turnips, carrots, potatoes, parsneps, or the like. The acreable produce would be enormous. I find that even the stoutest and most woody of the stems, when split with a knife into splinters small enough for a horse to masticate them, are freely eaten. The blossom is white, and the plant might easily be taken for *Melilòtus álba altíssima* ; but its transversely and subacutely rugose legumes indicate that it belongs to the second of your divisions of *Melilòtus* (*Hort. Brit.* p. 298.), in which division there is no species which corresponds with this plant in its characters, and therefore I conceive it is to be taken as a hitherto nondescript species. I mean to make the experiment suggested by M. Vilmorin in his *Bon Jardinier* for 1839, of employing it to support *Vicia villòsa*, which, this year, attained with me the length of 8 ft. — *W. P. Taunton. Stoke Bishop, Bristol, Sept. 26. 1840.*

SCOTLAND.

Melilòtus, or Bokhara Clover. — In recurring to your esteemed letter of 30th March, 1839, enclosing seeds of a *Melilòtus*, or Bokhara clover, which I last year acknowledged, from its gigantic growth, and, while tender, being eaten with avidity by horses and cattle, and from its extraordinary growth the first and particularly the second year, I think it may yet realise the anticipations of those who gave it last year such celebrity in the newspapers, and exceed your expectations as expressed in your letter. The plants stood below the ground last winter, and appeared above ground about the 1st of April : it grew with amazing rapidity ; I cut part to try if it yielded well after cutting ; the second growth came forward with equal rapidity, but, wishing to save seeds, I allowed the whole to flower afterwards. The first flowers appeared on the 7th July, and by the 22d it was literally covered with white blossom ; the plants branched out luxuriantly and reached the height of 10 ft. on ordinary black soil, and without dung. Last year no seeds ripened with me, this year it ripens well ; I enclose a spike, and shall be glad to give one to as many of your friends as you may wish. I yesterday sent a stalk to Messrs. P. Lawson and Son, for the Highland and Agricultural Society's show at Aberdeen, measuring 10 ft. 1 in. above ground : the roots are very large. In its botanic characteristics, it agrees with those of the *Melilòtus leucántha Koch* (see *Hort. Brit.*), only it has sometimes 2 seeds ; perhaps it is a gigantic variety of that plant ; at any rate, it deserves cultivation in the flower-garden from its elegant appearance, and in the field for its extraordinary weight of green food. As it ripens its seeds the second year in this part of the island, and I understand in England the first year after sowing, its culture will likely soon become

extensive, and its merits subjected to general scrutiny: its rind is used in Bokhara as hemp. — Archibald Gorrie. *Annat Cottage, Errol, Perth, Sept. 25. 1840.*

ART. III. *The West London Gardeners' Association for mutual Instruction.*

MONDAY Evening, Feb. 17. 1840. — Mr. Shearer read his paper "On the Culture of the Camellia." He began by observing that camellias, like heaths and geraniums, require a separate house to give them that attention and treatment which are proper for each genus. The splendid and beautiful colours in the flowers of the camellia form a fine contrast with the glossy green foliage which is so conspicuous at that early season of the year when they are most easily produced. His practice, when done flowering, was to raise the temperature of the house to 50° or 53°, in which heat they are more certain to mature the wood and to set the buds. Water should then be given liberally to the root, and syringings every morning and evening. Bunting to be used to shade them, from May until September, during sunshine. If any were observed to grow too much to wood, by discontinuing the watering it would give a gentle check, which would materially assist to set the buds. He would recommend inarching as the most certain and expeditious way of propagating camellias; tongue-grafting he also practised, covering the part with moss, which he found preferable to clay; then putting them under hand-glasses, giving but little air until they were united. The compost to be light and rich; two parts turfy loam, one part leaf mould, and one part sandy peat, with a little decomposed cow-dung; when desirable to grow them large, to be potted as soon as done flowering. If low shrubby plants are preferred, he would pot them in the autumn, giving a top dressing with rich loam and cow-dung. A good drainage for the camellia is indispensable, that no stagnant water may sour the soil. When required to flower them early, plants with the most prominent buds should be selected; the temperature to commence at 50°, rising gradually to 60° as the buds expand. He would select the double-striped variegata, Colvillii, pæoniaeflora, Chandlèrii, and corallina as the best for forcing. He attributed the falling off of the buds to the want of water, and recommended gardeners to allow no more than one or two buds to remain on each branch, as he was confident that the practice would insure a more certain supply, and very much increase the size of the flowers.

Mr. W. Keane returned thanks to Mr. Shearer for bringing forward, on such a short notice, his excellent paper on the culture of the camellia. It was a subject in which he felt particularly interested, as at Castle Martyr, the seat of the Earl of Shannon, where he lived, the camellia was the topic of conversation with all persons who visited the place. There were fourteen large specimens planted out in the open air about sixteen years ago, and they were all, in 1834, when he last saw them, from 12 ft. to 13 ft. high. The largest, a double white, was 13 ft. 6 in. high, and 22 ft. in circumference, and every season feathered with flowers from the bottom to the top. They were planted out in three quarters peat, and one quarter good rich loam, 3 ft. deep, with drainage of old bricks, lime rubbish, and rough gravel at the top. They were planted beside a wall with an east aspect; if the winter was severe, a few poles were placed in front, and mats were stretched from the poles to the wall, which was always found sufficient to protect them from the inclemency of the weather. They generally flowered beautifully in April and May. The system of propagation he recommended was, to take the cuttings in July, or any other time when the wood was perfectly ripe, and insert about ten or twelve in a large 60-sized pot, well drained, and filled with sandy peat and loam, but very little loam to be used, as the tender roots are found to grow better in sandy peat; when struck, to be potted singly into 60-sized pots; the cuttings to be any of the common sorts, which serve as good stocks for the better kinds to be

grafted upon them. To be grafted without tonguing, as the tongue is apt to decay; then tied with bast-matting; clay never to be applied over them, as the admission of light and air is found to be beneficial for the union of the scion and the stock. To be kept in a pit heated by dung to about 55° or 60°. In March to be planted out in sandy peat upon shelves within 2 or 3 feet of the glass, where they would grow rapidly until taken up, if required, for forcing the following season; potting to be performed when they were done flowering.

Mr. Caie was certain that, by proper management, camellias can be flowered, by exciting or retarding the growth of the plant to mature the wood and flowering buds, at any season of the year. He considered spring the best time for shifting them; all decayed roots to be cut away, and if the plants are in a sickly state then placed in heat from 60 to 70 degrees, where they are to remain until they have produced roots; the soil light sandy loam with good drainage, an abundance of water may be given with advantage, but it was a great disadvantage to keep them at a great distance from the glass, where they will not mature their buds. When the roots of camellias were coiled, he found it beneficial to tie haybands around the stems to retain the moisture, by which they were much invigorated.

Mr. Fish saw camellias flower pretty well 15 ft. and 16 ft. from the glass, but about 3 or 4 feet from the glass he observed them to flower better and more abundantly. He would recommend crown-glass to be used for camellia-houses, as defects in the glass are likely to concentrate the rays of the sun on the leaves of the plants, and to give the blotched appearance often to be observed on them; he has kept up a succession of flowering plants for seven months in the year. The temperature, when flowering, to be 60° in the day, 50° to 55° at night; the soil, one quarter leaf-mould, one quarter sand, one quarter peat, and one quarter loam. He considered good strong adhesive loam would be the best for growing large plants, but would not answer so well for flowering them. He agreed with Mr. Shearer, in the advantage of disbudding to produce large flowers; and also that water, by deficient drainage, stagnates and sours in the soil, which is the principal cause of buds falling off. He did not think the camellia a plant of easy culture, as it requires a great deal of attention to produce good forced flowers. He disrooted camellias which were in a bad state, then plunged them in dung heat, with the temperature at 50°, increasing as vegetation proceeded, allowing it to range as high as 80°, with sunshine.

Mr. Caie objected to bottom heat, as being injurious by exciting too much the plant that had been disrooted.

Mr. Massey agreed with Mr. Caie in the disadvantage of bottom heat. He saw fine camellias at Enfield kept in tubs, and put out in the summer in a shady place. He thinks too much water to be the cause of the buds falling off.

Mr. Caie believed that plants, at a great distance from the glass, were easily affected by too much moisture, as the air of the house would contain two parts hydrogen and one part oxygen. The open air is composed of twenty parts oxygen and eighty nitrogen, consequently there can be no carbon fixed in the plant.

Mr. T. Keane saw camellia and orange trees much injured by water, which were recovered by withholding it. He also considered that too much water was the cause of the buds falling off.

Mr. O'Loughlin admitted that camellias may be kept flowering nearly the whole year in large collections. He was opposed to close cutting and to bottom heat. The soil he would recommend to be three quarters peat and one quarter sand. To be potted when done flowering; the temperature to be kept between 45° and 50° at night, and 75° or 80° in the day; to be removed to a shady situation in the autumn, which is of advantage to mature the wood. He saw orange trees grown well in 60° bottom heat, and then gradually inured to the temperature of the orange-house.

Mr. Fish agreed with Mr. O'Loughlin in the advantage of bottom heat for

orange trees. He cut out the decayed roots, headed the branches at the same time, and plunged them in bottom heat, where they grew luxuriantly. From the similarity of the two genera, he considered it was confirmatory of the benefit of bottom heat for the camellias.

Mr. O'Loughlin approved of removing some of the buds, if too close or too numerous on the plant. He considered cuttings from the single red to be the best for stocks. He did not believe that tongueing was injurious to grafts, and recommended that the pots should be well drained with brick rubbish at the bottom, with rough peat over that to the depth of 5 or 6 inches, as the health of the plant mainly depended upon good drainage. He saw, in Dorsetshire, fine camellias 8 ft. to 9 ft. high, planted out in the open air, protected by a few thatched hurdles: they were not injured by the severe frost of 1837-38.

Mr. W. Keane believed that sudden changes of temperature were the causes of buds falling off; the heat he considers best to flower them is 60° by day, and 50° at night. When done flowering, the heat to be raised to 80° by day, and from 65° to 70° at night, to grow them well. When the flower-buds are set, the temperature to be gradually decreased, until placed out of doors in June in some shady situation; if wanted to flower early in the autumn or winter, they should be set growing early in the spring. He was opposed to the system of inarching with bottles of water in which to insert the end of the scion, as it requires too much nicety for general practice.

Mr. Gilfoyle agreed with Mr. Fish in the advantage of bottom heat for the orange trees, but did not think there was such an analogy between them and camellias, as to warrant a gardener to adopt the same practice for both. He believed that the camellia, by the nature of the plant, could transpire from the leaves but very little water, while, on the contrary, the foliage and wood of the orange were naturally more permeable, and could receive a greater quantity of water at the roots without fear of cankering them, or of souring the soil.

Mr. Caie observed that the constitution of the plants should be closely studied, to direct us in removing the buds and in the application of water, which may be freely given to healthy plants in the flowering season. In his opinion, the success of grafting does not depend upon the clay, bottle, or any other practice, but is mainly to be attributed to the beneficial influence of a close atmosphere.

Mr. T. Keane was sure that the idea of Mr. Fish was borne out by the fact, that the rays of the sun were concentrated on the drops of water which remained on the plants, by which the blotched appearance was given to the leaves; he approved of keeping them near the glass, and of shading them on hot sunny days.

Mr. Shearer agreed with Mr. Caie, that camellias could be grown nearly all the year round, and also in the advantage of keeping them near the glass to receive the benefit of light and air.

Monday Evening, March 5. — Mr. Robert Fish read an essay "*On the Shanking of Grapes.*" After some preliminary observations, he described the difference between shanking and shriveling, that the latter was generally a product of the former; he then mentioned having seen grapes shanked out of doors, in opposition to the opinion that they never were so. He adverted to the different reasons assigned as the cause of the evil; some considering it as arising from too much moisture, others from too much heat, and others from a deficiency in ventilation; and endeavoured to show that, while each of these causes might be somewhat instrumental, still the chief cause lay in the inability of the roots to sustain and mature the crops.

He corroborated this proposition by detailing the results of forcing a vinery three years in succession. The first season a very fair crop was taken, and the berries were beautifully swelled and coloured. The second season a heavier crop was taken, and there was a slight deficiency in colouring. The third season a still heavier crop was taken, and there was still a deficiency in colour-

ing, and a small number of bunches were considerably shriveled. The treatment every year being the same. The results seemed to indicate that, when the plant had got too much to do, it showed its unfitness for the task ; first, in a deficiency of colouring, and then in shanking and shriveling. He considered that the disease was not produced by a close moist atmosphere, as the house he referred to was heated partly by fermented dung placed inside the house, and always kept in a wet working state until the berries began to colour. Neither did he conceive that it proceeded from want of air, as he never gave any air at night before the fruit was colouring, and very little during the day ; although he was careful to give a little in the morning, that the leaves and fruit might be dried before the sun became powerful. Nor did he conceive it proceeded from too much heat, when that heat was properly applied ; that is, when a high temperature was kept up by day, especially in sunshine, and the house allowed to fall at night. He then mentioned instances tending to show that the imperfect state of the fruit was frequently owing to the keeping up of a high temperature both by night and by day, by which the excitability of the plant became exhausted before its proper functions were performed, and ended with advising to force the roots simultaneously with the tops. To keep a higher temperature during the day, and lower at night than was generally practised, and to give a little air the first thing in the morning.

Mr. Russel attributed the shanking of grapes out of doors to the confined situation in which they were placed. He attributed shanking solely to the management. He mentioned some instances for the purpose of showing that extremes of temperature and sudden changes would effect it, but did not consider that it was at all owing to the crop or to the state of the roots.

Mr. Caie considered that shanking was in some degree promoted by not regulating the temperature according to the constitution of the plant. He confirmed this idea by detailing instances of some vines bearing shanks and unhealthy bunches in the same house in which others were healthy and luxuriant.

Mr. Adams considered that the evil did not proceed from irregularity in giving air, as he had seen the bunches shank for years where the utmost care was taken. He thought it arose from the borders of the houses referred to being deep, as he conceived that as the heat in the human body was produced by the formation of carbonic acid gas, so the heat in the earth, produced by the same means, would be quite sufficient, provided a little litter was scattered over the border, to prevent the radiation of that heat.

Mr. Russel stated that it was a remarkable fact that carbonic acid gas should produce heat, as he had been informed it had lately been compressed into a solid, and constituted the most powerful freezing principle.

Mr. Stormont could assign no reasons for the shanking of grapes, after having seen a great many methods to prevent it.

Mr. M'Kenzie considered a damp stagnant atmosphere as the principal cause ; advised thinning the berries well, and letting in plenty of air, by removing all superabundant leaves and shoots, and giving plenty of nourishment to the roots, especially if planted inside.

Mr. Grey did not think the shanking proceeded either from an irregularity in giving air, or from a too high temperature at night. He alluded to a vinery kept regularly to 75° at night, and there was not a shanked berry in the house. He also mentioned instances tending to show that moisture in the atmosphere was not the cause, but thought it might be the result of the tree exerting itself to get rid of what it could not bring to maturity. He also mentioned an instance of grapes being cured of shanking by burying two dead horses in the border, showing that the plants had wanted nutriment. He also had seen the disease remedied by raising the roots.

Mr. Massey considered we had made no progress in the cultivation of the grape, as the disease was always becoming more prevalent. It was considered to be chiefly owing to the state of the borders. He had generally found vines planted inside worst, which he attributed to deficiency of nutriment and

watering. Wherever he had seen good borders and high cultivation, he had never seen shanking. In low deep borders, he considered shanking was produced by the rotting off of the young roots; in corroboration of which he stated he had seen such houses shanked in wet seasons, and free from shanking in dry.

Mr. Fish shortly replied: considered that many of the statements confirmed his own propositions, and that the uncertainty on the subject should animate us to greater diligence and attention. He also showed the necessity of heating the border externally in early forcing, as, even allowing Mr. Adam's theory to be correct, there would be little evolution of carbonic acid gas in the soil, if protected by a covering from the influence of the air.

W. Keane, Secretary. July 15. 1840.

ART. IV. *Retrospective Criticism.*

THE Plates to Prince Puckler Muskau's "Hints on Landscape Gardening," (Andeutungen über Landschaftsgärtnerei, &c.)— [Having shown these plates to John Adey Repton, Esq., who was employed by Prince Puckler Muskau as architect and landscape-gardener, he sent us the following remarks, which we requested his permission to publish.]

I was much disappointed, in looking over the publication of the improvements of Muskau, to find that the designs for the mansion, instead of being those of an old château, were only those of a modern Italian villa, although the latter may please many who prefer it to the "odious ugly old castles!"

As the prince said that the estate had been in the possession of his ancestors more than two centuries, I had taken much pains to add to the respectability of the château, by giving it an appearance of antiquity, as far as the modern rows of windows would allow me to do; and indeed the building had been modernised about the year 1750: and, instead of the present cotton-mill-like appearance, and the ugly hipped roofs, I had endeavoured to give it the picturesque character of the 16th century, with lofty and enriched gables and dormer windows. The present style of the building would not allow me to introduce the bow-windows of Henry VIII. or Elizabeth, without pulling much of the building to pieces.

You are as well aware as myself, how difficult it is to represent the beauties of nature in a picture. There is no doubt that the prince, from his good taste, has added much to the improvement of his place, of which the engravings you showed me can hardly give any just idea, the landscape being represented in black and white. These engravings appeared rather the works of an amateur than that of a painter. The little shrubs dotted about may appear very beautiful in nature from the great variety of their colours, which it is not very easy to represent on canvass.

I send you the enclosed sketches [which we intend at some future time to engrave] of Muskau, showing the mansion, and the improvements I proposed for it, and, should these sketches be of use to you for any of your publications, you are welcome to apply them. I also enclose the design for the mansion at New Hardenberg, near Berlin, the seat of the late Prince Hardenberg.

You will see by the enclosed sketches that I never could have recommended the three gigantic arches shown in the engravings in Puckler Muskau's book. The fashion of the present day seems to admire every thing in a great dimension; as the lofty porch at Fonthill, the modern porch at Warwick Castle, &c. These generally act as a scale, and destroy the magnificence of a building. The windows to the buildings at Fonthill, by the sides of the great arch of the porch, look like so many pigeon holes; or like the Lilliputians near Captain Gulliver. Look at the large arch at ————, near ————. It reminds me of a small sprat with great eyes.

I paid a morning visit lately with a friend to a gentleman not a hundred miles from ————. We had a long tedious drive for miles round his place, the trees consisting chiefly of firs; and such is the vanity of mankind, that a

person generally prefers the trees of his own planting, no matter what they are, to the most venerable oaks in a park or forest. Of these tedious walks or drives my late father used frequently to say, that "No stranger would go the second time unless you make him." And of a formal belt to hide a beautiful prospect, or rather to hide what does not belong the owner, his expression used to be, "These miserable belts to shut out mankind!" — *John Adey Repton. Springfield, near Chelmsford, Oct. 1. 1840.*

The Van Mons Leon Leclerc Pear. — Being an attentive reader of your interesting Journal, I have not failed to remark the criticism which you have made (p. 266.) on the name given to the new pear raised by me, and introduced into England by M. René Langelier. Far from disclaiming this criticism, I am the first, on the contrary, to acknowledge its justice; but, after this confession, you will allow me, I hope, to say a few words, if not to excuse myself, at least to explain the cause of this immeasurable length which has shocked you so much. The case is this: Full of gratitude for the signal services which M. Van Mons has rendered to science, and in particular for the special marks of kindness he has shown me, I eagerly seized the opportunity of the pear in question appearing in my nursery to submit it to M. Van Mons. The pear appeared to him to be of the very first rank (such were his expressions), and he was willing to accept of the dedication to him, but being under the necessity of distinguishing this new variety from several others which already bore the name of Van Mons, it was this venerable patriarch of pomology himself who desired that my name, very unworthy no doubt, should be placed after his to serve as a distinctive character. Was it my place to refuse this mark of his kindness? In acknowledging myself again guilty, as I did at the beginning of this letter, I may hope that, in condemning me with full justice, you will at least allow me the advantage of attenuating circumstances.

With respect to the novelty of this fruit, which some persons, it appears, have called in question, I cannot find a better method of removing all doubts on this head than in having the honour of sending you some specimens, which M. Langelier (René), my respected correspondent, undertakes to transmit to you.

Accept, Sir, the expression of my gratitude for all the pleasure which I have derived, and still continue to derive, from your valuable publications of different kinds, and all of the highest esteem. — *L. Leclerc. Laval, Département de Mayenne, Sept. 26. 1840.*

The passage alluded to occurs in a Review by J. B. W., one of our most valuable correspondents, in p. 266.; and we regret its appearance, not only because it has caused pain to M. Leclerc, but because it stands there a proof of our own neglect in not carrying out a principle which we have always taken as a guide, viz. never to condemn, or let others condemn, anonymously, or pseudo-anonymously, without assigning a reason. M. Leclerc has fully justified the name given to the pear, as far as he is concerned, and with reference to the present state of fruit nomenclature. With respect to the merits of this pear, we have received the two specimens from the parent tree referred to by M. Leclerc, and mentioned by M. René Langelier in a separate letter, and we certainly think they are by far the best pears that we ever tasted. They were perfectly ripe on the 15th October, as large as the largest Duchesse d'Angoulême, and shaped a good deal like that fruit, with a flavour remarkably rich, and, as it appeared to us, partaking of that of the pineapple, and consequently having more acidity in it, joined to sugary richness, than is the case with most pears. A more perfect description of it, however, will doubtless be prepared by Mr. Thompson. In the meantime every possessor of a garden, who wishes to grow what really appears to be the best pear in existence, will lose no time in possessing themselves of a scion or a tree of this variety. — *Cond.*

THE
GARDENER'S MAGAZINE,
DECEMBER, 1840.

ORIGINAL COMMUNICATIONS.

ANNUAL SUMMARY.

A Summary View of the Progress of Gardening, and of Rural Improvement generally, in Britain, during the Year 1840; with some Notices relative to the State of both in Foreign Countries. By the CONDUCTOR.

WEATHER of 1839-40. — We are indebted to the same scientific correspondent, who furnished us with the paragraphs on the weather in our last year's report, for what follows: —“ The months of November and December, 1839, were exceedingly wet; and the amount of rain in the first month of the present year was $2\frac{1}{2}$ in. nearly, or almost double the average quantity for January. The temperature was about 39° Fahr., being 3° above the mean. Towards the end of the month, the weather was frequently very boisterous, particularly on the 24th and 26th. In February the same damp condition continued till the 17th; after which, the wind changed from south-west to easterly points, and no more rain fell during the month. The mean temperature was below the average, and vegetation was in consequence beneficially retarded. March was cold and dry, the wind being chiefly from northerly or easterly points. The mean temperature was nearly 4° below the average of the month. The amount of rain was exceedingly limited, being scarcely $\frac{3}{10}$ of an inch. Vegetation made very inconsiderable advances. The weather in April formed a remarkable contrast with that experienced in the corresponding month of several previous years. In these the solar rays were almost constantly obscured; but in this month their intensity has probably been rarely equalled in the neighbourhood of London. The nights, as might be expected, from the clear state of the atmosphere being so favourable to the radiation of terrestrial heat, were frequently frosty. This circumstance considerably affected the mean temperature; yet the latter was above the average, and the increase may be said to have been effected by direct solar heat, unaided by the usual stream of warm air introduced with south-west gales, and notwithstanding the counteracting tendency of winds from cold quarters. On the 25th, the thermo-

meter was 80°, and on the 28th 81°, in the shade. On the 1st of the month, the standard almonds were in blossom, being about 12 days later than in 1839. This arrear was, however, brought up by the 18th, when the hawthorn (*C. Oxyacantha*) was in leaf 2 days earlier than in the previous year. In a few days after this, the horsechestnut burst into leaf; the birch (*B. álba*) began to appear green on the 28th; the beech (*F. sylvática*), the fig (*F. Cárica*), and the walnut (*J. rëgia*) came into leaf between the 1st and 4th of May. The month just mentioned was more favourable to vegetation. There were a few slight frosts at night; but the vicissitudes of temperature were by no means so great as that experienced in April. Showers were plentiful, and the temperature about an average. The same remark applies to June. But instead of the mean temperature of July advancing several degrees, as is usually the case, it scarcely equalled that of June in the present year. To this circumstance is doubtless to be ascribed the lateness of the period to which the maturation of many productions was delayed, for whilst those months which preceded this maintained their average, as has been stated, the one which followed proved 2° above it, the mean temperature of August being 64°. September was rather a cold and wet month; and, as early as the 17th, a sharp frost occurred, which materially affected the growth and flowering of the dahlias. October proved more favourable, and afforded a fair share of dry weather, sufficient for collecting and storing up the production of the seasons."

Crops of 1840. — "It may be observed from the preceding statement, that the winter of 1839–40 was, on the whole, mild, but exceedingly damp till the middle of February, owing to the unusually large quantity of rain, and the very limited degree of evaporation which at any interval was being carried on. Cold dry weather set in after the above-mentioned period. Vegetation was late, at least it had made but little progress up to the commencement of April; but was considerably advanced, in consequence of the brightness and high degree of solar heat which were experienced in that month. Blossoms were brought forth in good perfection; but, owing to the frosts at night, many of the apple blossoms were destroyed in low situations, and, in such, the crop of this kind of fruit was but partial. Plums, cherries, and pears were less injured, and the crops of these have been very abundant. The months of May and June were favourable in every respect; but there was a drawback with regard to temperature in July, whilst, at the same time, vegetation, in many instances, was deficient of moisture. When rains became plentiful in the succeeding months, fruits materially increased in size; but this happening so late, there was neither time nor sufficient solar heat to convert the recently envolomed

watery juice into the richer saccharine nature, which is produced in fruits when they are duly supplied with moisture in the early and middle period of growth, and then ripened off in dry sunny weather. In September, frosts at night were frequent, and sometimes very sharp; this was certainly not favourable to perfect ripening, although it may tend to bring the process to an imperfect termination. Grapes on walls were generally very defective, as regards quantity; the wet and dark previous autumn was doubtless the cause of their not showing blossom; and in ripening, after exposure to a certain degree of cold at night, the saccharine formation process is found to be arrested."

History and Statistics.—The present volume of the *Gardener's Magazine* contains few additional facts relative to the past history of gardening, but many relative to its present state, both in Great Britain and other countries. We refer to the numerous notes on country seats, the names of which will be found in their proper places in the Table of Contents; and to the articles on the Gardening of Italy by Manetti (p. 70. and 241.), on that of Egypt by Dr. Bowring (p. 564.), and to those on America by Mr. Downing (p. 658.) and Mr. Gordon (p. 63. and 660.). Perhaps the most interesting historical fact which has occurred in England in the course of the year is the completion of the Derby Arboretum, an account of which will be found in this volume (p. 521.), and a much more ample one in a separate pamphlet, entitled the *Derby Arboretum*.

Science of Vegetable Culture.—Perhaps the most valuable article in this year's Magazine is the one on the Science of Horticulture, by Mr. Lymburn (p. 425.). It ought to be perused again and again by every young gardener, in connexion with the volume which gave rise to it. The articles next in value we conceive to be those on supplying atmospheric moisture to hot-houses, and on conical boilers, by Mr. Rogers (p. 122. and 196.), and the account of Mr. Penn's mode of warming and ventilating hot-houses (p. 120.). Mr. Penn's mode of warming and ventilating, we conceive to be the greatest practical improvement that has been made known in the course of the year. The essential advantage which it procures is, that of rendering a temperature of 80°, even though accompanied with moisture in the atmosphere to the point of saturation, as agreeable as one of 60°; and, consequently, rendering a moist stove, or orchidaceous house, as fit for the most delicate lady to breathe in as a greenhouse. There is nothing that is not easily accounted for in the difference of the human feelings experienced when we stand in air in motion, as compared with those which we experience when standing in air in a stagnant state; the same results being felt in a warm day, when there is a breeze, as compared

with a warm day when there is no breeze. The great importance of this improvement has induced us to question every person, that we have seen, who has visited Mr. Penn's establishment at Lewisham during the last summer; and we have invariably found that they agree with us in our opinion of it; and one writer, a scientific gardener of great practical experience, N. M. T., p. 640., is even more sanguine than either ourselves or Mr. Willmot. The last gardener that we have seen who visited Lewisham was Mr. Reith, head gardener to the viceroy of Ireland. About the middle of October, he was in Mr. Penn's orchidaceous house, when the temperature was at 80° , and found it as agreeable as that of a green-house, or the room of a dwelling-house, with the air at 60° . Mr. Reith is the reverse of a theorist, and had only recently heard of Mr. Penn's improvement; he did not even know that there was any account of it published in the *Gardener's Magazine*, and hence he could have no previous prejudices respecting it. The articles on atmospheric moisture, and heating by hot water, by Mr. Rogers, deserve to be carefully studied by every person who has the management of hot-houses, or is about to build or heat plant structures. There appears to be no doubt of Mr. Shewen's boiler being the best for garden purposes, on a moderate scale, that has yet been brought into notice.

Landscape-Gardening. — The principal remarks on this subject will be found in our Notices of Country Seats and Gardens (p. 49. 233. 329. and 569.); and it is, perhaps, in the form in which we there introduce them, that they will be found of most use to practical gardeners. In this way we intend to illustrate one principle after another till we go through the whole science of the art. We have, in the present volume, spoken for the first time of the axis of symmetry (p. 233.), a most important subject when rightly understood. The axis of symmetry is founded on this principle: that all the most beautiful objects or scenes in nature are symmetrical; that every symmetrical object forms a whole; and that every whole consists of at least three parts, a beginning, a middle, and an end; or, in other words, a centre and two sides. Now, in this centre, whether visible, or supplied by the imagination, is the axis of symmetry. In the simplest kind of symmetry, the two sides are equal and alike, and the axis is, of course, easily discovered; but in cultivated and refined symmetry, the sides are unequal, and so combined and varied with the centre, that it requires the eye of a philosophical artist to detect the axis; which, in other words, is called the axis of the composition. If it is once admitted that no scene can be truly beautiful or satisfactory that is not more or less symmetrical, then we have only to search for this quality in every building or landscape presented to us for

examination, for the purpose of supplying it where it is wanting, either by abstracting what interferes with it, or by the addition of what is necessary to render it effective or obvious. But, though every artist will allow this to be theoretically true, yet he will also allow that it requires great practical experience to be able to carry the idea into effect, especially in general scenery. In the case of a house, or a group of buildings, the difficulty is not great, because all the forms in buildings are definite and permanent; but in landscape, all the forms are indefinite, and continually changing by growth, by decay, and even by the seasons of the year. Those who have thought much on this subject will discover that the idea of rendering every object or scene symmetrical is but a more accurate and detailed analysis of the expression, "rendering any object or scene a whole." The advantage of treating the subject in this manner is like that of presenting the same object under different points of view: we become better acquainted with it.

Breadth of effect has also been touched on in several places, because without it, that is, in common language, without broad naked surfaces or glades of turf among trees and shrubs, there must either be monotony or confusion in either a park or a pleasure-ground; monotony if the ground is uniformly covered with trees or shrubs, and confusion if it is covered a little more in some places than in others, but not sufficiently uncovered in any place to produce repose or breadth of effect, that is masses of light or masses of shade. The use of these naked places in parks and pleasure-grounds is, to contrast with the covered places; because it is by this contrast that what is called the effect is produced. In other words, a thing is what it is only by comparison with some other thing. If there were only one colour, there could be no such distinction of colours as red, blue, &c.; and if there were no light, there could have been no such thing as darkness. Every large object looks still larger when a small object of the same kind is placed near it; every particular form, such as a cube, appears still more definite or particular when it is opposed to a form of an opposite kind, such as a globe; and every colour appears more intense when it is placed adjoining its contrasting or complementary colour. In short, there is not a principle in the whole art of composition, whether of architecture or landscape-gardening, or, indeed, of any of the fine or mixed arts, so constantly brought into requisition as that of contrast, unless, indeed, it be that of connexion. The whole art of landscape-gardening, landscape-painting, and architecture, with reference to effect, may, indeed, be resolved into the exercise of these two principles.

There is one prevailing error which belongs to the department of landscape-gardening which we have noticed in different

parts of this volume, and to which we shall here recur, viz. the acute-angular forms of dug beds for flowers and flowering shrubs, which are commonly to be found on lawns. Beds, the outlines of which form acute angles, are bad in themselves, because they never can be completely covered with flowers or shrubs at the angles, and because if the eye of the spectator who observes them is not on a much higher level, the shape of the bed, of which the angle forms so conspicuous a feature when near, is not recognised. For all ordinary purposes, therefore, we consider acute-angled beds as ineligible; though, for symmetrical designs, in situations where the design is commanded by an elevated walk, or surrounding terrace, they may with propriety be introduced; because, in such situations, their forms and combinations display them to almost all the advantage of which they are susceptible. It is lamentable to see the pleasure-grounds of some of the finest old places in England spoiled by the introduction of these angular beds, in the most romantic or otherwise strongly marked scenes, that no man of taste would dare to touch; the beds perhaps planted with dahlias, hollyhocks, or China roses.

We wish we could strongly impress on the mind of every amateur, and of every gardener, that, for all general purposes of planting beds of shrubs, or beds of flowers on a lawn, to be laid out in the modern style, the best form is the circle, provided that it be always kept of small size, say from 18 in. to 6 ft. in diameter, one circle never placed nearer to another than 2 ft., and that these beds be thrown together in groups or constellations, as stars are in the firmament, or single trees and single shrubs in a well planted park.

We do not say that there are not cases where large angular masses, or long variously outlined shapes, may not be preferable to circles, or ought not to be introduced along with them. On the contrary, though in a park we would effect the great part of the planting by single trees, and small groups, as we would on a lawn by circular beds of different sizes, yet there may be cases in both where a particular practice requires to take the place of a general one. The principles, indeed, which guide the disposition of the kind of circular beds that we recommend, are exactly the same as those which guide the disposition and grouping of single trees. Wherever large masses of shrubs or flowers are wanted, there a greater number of circles of different sizes are to be brought together; and wherever any particular general form is to be produced, the body of that form may consist of beds in the form of circles, the general outline of which will constitute the form required. In short, as every mass of wood is composed of single trees, so every mass of shrubbery, or of flowers on a lawn, should or might be composed of single circular beds of different sizes.

Some persons who do not understand the difference between the effects of shapes on paper and shapes on ground, and between looking down on a lawn or flower-garden, and looking at it sideways, will object to having nothing but circles, as wanting in variety; but, in practice, it is found that, by combinations of circles of different sizes, more variety is produced than can be effected by the use of any other form whatever, unless we except small squares or small polygons, to which we have no objection except that the angles are not so easily filled up with flowers as circles. To show that combinations of circles are productive of more variety than any other form, we may observe, first, that the circles, being always seen from the side of the combination, change their apparent position with every change in the position of the spectator; and, secondly, that when the circles are planted with flowers, one or more of which in every bed rise to the height of 2 or 3 feet, the shape of the bed, whatever it may be, can never be recognised by the spectator from a side view. The size and the connexion, therefore, in this case, is of much more importance than the shape. As well might combinations of single trees be objected to in a park, as combinations of small circular beds on a lawn; for, as a single tree, in combination with other single trees, is no longer a detached object, but forms a part of the whole to which it belongs, so a single circular bed, in combination with other circular beds, is no longer to be considered as a circle, but as the element of a combination which may form a varied and extensive figure, according to the circumstances of the situation and the object in view.

The only fear that we have in recommending circles so strongly is, least our doing so should revive the old system of clumping in parks; but we hope it will always be borne in mind that we recommend no circles larger than 5 or 6 feet in diameter, and none to be placed in such an isolated position as to be unconnected with any thing else, and to attract attention as single and detached objects.

It is observed by George Cumberland, that "taste is a slow-growing excellence, and that the proof of its advances must arise out of facts. . . . The most likely mode to promote it," he observes, "must also be to give proofs as to its having taken a right direction somewhere, so as to draw attention to that source, from which, the fountain being pure, useful channels may be opened, and wholesome examples adduced." (*Bromley Hill*, p. 5.)

Now, in conformity with this precept, we shall refer to a few places, all near London, where circles are used on the lawn, or in the flower-garden, exactly in the manner which we have been recommending. We may previously observe that circles were chiefly used by Mason the poet, in laying out the flower-garden at

Nuneham Courtenay near Oxford; and by Major Price, brother to Sir Uvedale Price, in laying out the flower-garden at Mongewell House near Wallingford, for Daines Barrington, bishop of Durham. Circles and ovals, it will also be recollected, have been adopted by Mr. Wells in the English flower-garden at Redleaf; in proof of which we refer to the engraving of this garden in vol. xv. p. 365. The places that we allude to, and which we should desire to be taken as examples, are, Norbiton Hall near Kingston, Teddington Grove near Teddington, Trent Park near Southgate, and Bayfordbury near Hertford. The last place being the largest in extent, and containing the greatest variety in the diameters of the circles, we consider as a singularly felicitous example. (See p. 588. and 589.)

Arboriculture.—A number of new species of hardy trees and shrubs have been introduced by the Horticultural Society in the course of this and of the preceding year, which are noticed in Mr. Gordon's Reports, p. 1. and p. 631. The chief points in the subject of Arboriculture, to which we wish to direct attention are, the mode of planting above the surface, as practised in the Derby Arboretum (see p. 534.), and frequently recommended in this Magazine; the mode of managing trees and shrubs in an arboretum, also pointed out in the description of that at Derby (p. 542.); and an improved mode of making plans for planting the grounds of small residences, which we shall here briefly describe.

The selection of trees and shrubs for planting the grounds of villas is a subject to which we wish particularly to direct attention. At present, when a gentleman builds a house, he gets at the same time, or after the house is built, a plan for laying out the grounds. This plan displays walks, lawn, beds of flowers or shrubs, and single trees, and plantations; and the gardener or nurseryman is employed to carry the plan into execution. There being no particular directions respecting either the kinds of the trees and shrubs to be employed, or the manner in which they are to be disposed, the planter necessarily exercises his own taste and knowledge. If he is a gardener of the old school, knowing but few kinds of trees and shrubs, then these few kinds are all that he orders from the nurseryman; and if he is a small nurseryman in the country, who only cultivates a limited collection, the choice being left to him, he very naturally employs only such kinds as he has in his grounds, and he most probably leaves the disposition of them to his foreman, or to the gentleman's gardener. In this way, the collection of trees and shrubs about a place, and more especially a small one, and their disposition, are left in a great measure to chance.

Now, instead of proceeding in this indefinite manner, we would have every individual tree and shrub that was to be

planted, with the exception, perhaps, of the smaller species and varieties of peat-earth shrubs, indicated on the plan. By this means, a greater number of species may be got into even the smallest place, and the execution of the plan may be reduced to almost the same degree of certainty as the execution of an architectural design. The chief interest of every small place must necessarily depend on the variety of trees and shrubs with which it is planted; and the interest of all large places is greatly increased by the same means, while the general effect, which depends on masses, is preserved. In some very fine country seats, where the masses about the house are exceedingly well placed with reference to the distant scenery, they are planted with the commonest trees and shrubs, the most conspicuous evergreen being the common laurel. This is exceedingly offensive to an eye accustomed to see the finer description of trees and shrubs always placed near the house; while nothing is gained in point of effect, because the same mass might be produced by cedars and rhododendrons, and other such plants, that is now done by laurels and larches. The grand cause why the number of species of trees and shrubs planted about country seats by modern landscape-gardeners is so limited, is the prevalence of the idea that picturesque beauty is the sole object of plantations. This idea may, in a great measure, be traced to a mistaken view of the writings of the late Sir Uvedale Price, who ridiculed the idea of collecting together all kinds of plants in a shrubbery, without paying any regard to their disposition with reference to picturesque effect. Picturesque beauty, however, may be produced as effectively by a numerous collection of trees and shrubs, as by the assemblage of a few species. Nay, we will go further, and assert that, by planting every species by itself in groups or masses connected with one another in the manner which we have often described in this Magazine, the picturesque effect will be great in proportion to the number of species employed. But, independently altogether of picturesque effect, the planter ought to enquire whether there are not other beauties and effects which merit his attention. Is not the mere botanical beauty of each species a source of interest to those who have paid some attention to plants, even in a general way, just in the same manner as the picturesque beauty produced by them is a source of interest to those who have bestowed some study on the picturesque? The truth is, that the greater part of the beauty of scenery, and of the external world in general, depends on the cultivation of our minds. A person who knows nothing of picturesque beauty in pictures, engravings, or books, can have no love for it in nature; and one who scarcely knows one plant from another will derive little more pleasure from a collection of different species of plants, than from an assemblage

of a number of plants of the same species. The cultivation of the art of sketching landscape gave a relish for natural scenery, and led to the substitution of the modern style of gardening for the ancient; and the prevailing taste for botanical studies is paving the way for a further improvement in the modern style, by the introduction of a greater number of species and varieties into our parks and plantations.

We would strongly recommend, therefore, all those who procure plans for laying out grounds, to require the artist to specify the name of every tree and shrub which he wishes to be planted in them, and to mark the places of each on the plan. Copies of the lists of plants can then be sent to different nurserymen, requiring them to affix the price to each species, mentioning, at the same time, the size of the plants; and, when this is done, it will be found that a tolerably complete collection of trees and shrubs may be planted for nearly the same price as the ordinary mixture of common sorts. As a proof of this, we refer to our list of the trees and shrubs in the *Derby Arboretum*, with the London prices affixed, p. 73.

It is highly satisfactory to us to find that a taste for planting collections of trees and shrubs is gradually spreading throughout the country. One of the most complete arboretums in England, and one in which ample space, we are informed, has been given for the growth of every plant, has just been completed for Lord Rolle at Bickton, by his most intelligent and enthusiastic gardener, Mr. Glendinning. One, as we have seen (p. 588.), has been commenced at Bayfordbury, where there is already a very complete Pinetum; and some others are projected, of which we expect to be able to give accounts in the course of our next volume. If we could only convince proprietors of country seats how much more permanent the beauties produced by trees and shrubs are to those of herbaceous plants, we are persuaded that there would not be a proprietor throughout the country who would not be anxious to increase the number of species in his park and plantations. We would remind them of what Du Hamel has said on the subject of the superior beauty of trees and shrubs, as quoted in our *Arboretum*, and we would also refer them to our own comparative view of ligneous and herbaceous plants given in p. 533. Gardeners who have a taste and knowledge of trees and shrubs themselves might often communicate this taste to their employers, if, like Mr. Glendinning, they added to a thorough knowledge of their profession a certain degree of enthusiasm for it. We have been informed by a respectable nurseryman, that Mr. Glendinning has done more for spreading an improved taste for gardening in Devonshire, by his operations at Bickton, than any individual that has appeared in the county for the last twenty years. It

is a great mistake to suppose that the state of the gardens and the botanical riches of a country residence depend on the taste of the proprietor or his family; it depends much more on the knowledge and the tact of the head gardener.

Floriculture.—A number of very excellent papers will be found on this subject, and particularly several on the culture of cacti and bulbs. The idea of grafting the finer kinds of New Holland acacias on the hardier species is good, and might, doubtless be applied in the case of other green-house and hot-house plants to a much greater extent than it is at present. The article on conservative walls (p. 23.), and the account of the conservative wall at Chatsworth (p. 573.), will, we trust, induce many proprietors to adopt this garden luxury, which, in our opinion, is one of the greatest that can be added to a country seat, next to that of an arboretum. In many places, the mansion, or, at all events, the offices, are connected with the kitchen-garden by a wall; and this wall, and also the exterior of the offices, might almost always be treated as a conservative surface for training half-hardy plants. But, independently of these sources of conservative situations for plants, when the interest which attaches to this kind of scenery and culture shall be better understood, we shall doubtless have walls, and perhaps entire gardens, formed on purpose for half-hardy articles. All the borders, and also the walls, might be so arranged as to be heated artificially at pleasure; and at pleasure, also, drained or irrigated artificially: for, to make the most of plants against a conservative wall, they ought to be urged on by heat and moisture in the early part of summer, and their wood ripened by withdrawing moisture and supplying heat in the early part of autumn.

The cultivation of annual flowers has greatly increased throughout the country generally, principally through the many new kinds that have been introduced by the London Horticultural Society, and partly through the publication of Mrs. Loudon's *Flower-Garden of Ornamental Annuals*, during the past year. It is particularly gratifying to observe the number of these annuals which are now to be found in the front gardens of street-houses. The street gardens of London and Brighton, in this respect, have undergone a complete revolution within the last ten years, by partaking of these and other improvements, which formerly were confined to the gardens of gentlemen's seats.

Horticulture.—Two valuable communications on the culture of the grape will be found in p. 89. and p. 598.; but one more especially in our notes in p. 570., in which a mode, which we witnessed in May last, is described, of growing three crops of grapes in one house in one year. The article on the culture and preservation of potatoes, in p. 210., and that on the wild potato in p. 259., are both full of instruction and interest. Frozen

potatoes, it will be observed in the latter article, may be preserved for a number of years, and yet retain their nutritive properties. One of the most valuable papers on practical horticulture in the present volume is one by Mr. Drummond, quoted from the *Horticultural Transactions*, "On the Cultivation of Pears, and the Management of Fruit Borders" (p. 402.). It is full of instruction, and ought to be maturely studied by the young gardener.

Agriculture and Domestic Economy, including *Bee Culture*, will be found to have received their customary share of attention as secondary objects; but we consider it unnecessary to do more than refer to the Table of Contents, more especially to our Miscellaneous Intelligence.

Garden Literature.—A great many books have been reviewed or noticed in the present volume, of which three are of peculiar value: De Candolle's *Vegetable Organography* (p. 163.), Liebig's *Organic Chemistry, in its Application to Agriculture and Physiology*, and Dr. Lindley's *Theory of Horticulture*. The last book ought to be in the possession of every gardener, and the others in the hands of all who can afford to procure them. Professor Liebig's work is the most valuable of the kind which has been published since the days of Sir Humphry Davy. It has generally been supposed that the chief source of nutriment to plants depends on the presence in soils of a substance to which the name of humus has been given, and which is extracted or absorbed by them during the process of vegetation; this notion of the absorption of a solid substance by plants has hitherto prevailed among physiologists who have considered the subject; and in the 6th edition of Sir H. Davy's *Agricultural Chemistry*, it is stated that "vegetable and animal substances deposited in the soil, as is shown by universal experience, are consumed during vegetation, and they can only nourish the plant by affording *solid matters capable of being dissolved by water*, or gaseous substances capable of being absorbed by the fluids in the leaves of vegetables; but such parts of them as are rendered gaseous, and that pass into the atmosphere, must produce a comparatively small effect; for gases soon become diffused through the mass of the surrounding air. The great object in the application of manure should be to make it afford as much *soluble matter* as possible to the roots of the plant, and that in a slow and gradual manner, so that it may be entirely consumed in forming its sap and organised parts." Professor Liebig dissents from this opinion, and adduces the most complete evidence that humus, in its pure form, or as it exists in the soil, does not yield the smallest nourishment to plants, in consequence of the low soluble power of this substance, either alone or in combination. He therefore concludes that the carbon must be derived from other sources, chiefly, though not entirely, from the atmosphere, by the decomposition

of the carbonic acid, of which carbon is assimilated, and the oxygen is again restored to the atmosphere. This opinion is certainly not new, but it has scarcely been generally appreciated, in consequence, Liebig considers, of the imperfect knowledge of chemical principles by naturalists, and the want of any decided physiological experiments to determine the point. "Nature," he says, "speaks to us in a peculiar language, in the language of phenomena; she answers at all times the questions which are put to her; and such questions are experiments." On the other hand, Professor Liebig believes that the chief influence exercised by humus on vegetation arises from its being "a continued source of carbonic acid, which it emits slowly. An atmosphere of carbonic acid, formed at the expense of the oxygen of the air, surrounds every particle of decaying humus. The cultivation of land, by stirring and loosening the soil, causes a free and unobstructed access of air. An atmosphere of carbonic acid is, therefore, contained in every fertile soil, and is the first and most important food for the young plants which grow in it." A variety of other interesting matter is discussed in this volume: such as the transformations or metamorphoses which take place in the organs of plants; the assimilation of hydrogen and nitrogen; the art of culture; the interchange of crops and manure, &c. *Instructions in Gardening, for Ladies*, by Mrs. Loudon (p. 350.), is by far the best book for grown-up gardening ladies that has ever appeared; and there is not perhaps another lady in England, or a gentleman either, who could have produced such a work. We state this, because, to have done so, it is necessary for the writer to have been in the very peculiar circumstances of the authoress previous to writing it, viz. to have arrived at maturity before she began to study either gardening or botany. (See the preface to the work, copied in p. 350.) A *Pocket Dictionary of Garden Botany*, by Mr. Paxton, will be found an exceedingly useful book for amateurs. The new *Flora of North America* (p. 558.) is an admirable work, which ought to find its way into the library of every botanist; as should Royle's *Illustrations of the Botany of the Himalayan Mountains* (p. 348.). Both these books contain descriptions of many hundreds of plants, ligneous and herbaceous, which are adapted for growing in the open air in this country; and for that reason they are particularly deserving of the attention of the cultivator. Many of the plants alluded to will be yearly sent home, and references will be continually made to these works, to ascertain their native habits, on which will be grounded the kinds of culture which they require. Kollar's *Treatise on Insects injurious to Gardeners, Foresters, and Farmers* is by far the best work of the kind for the practical gardener that has ever appeared; and it is not too much to say that

a copy of it ought to be in the hands of every gardener, young and old; for such is the number of insects which attack garden productions, that some knowledge of their natures is become almost as necessary to the gardener as some knowledge of botany and vegetable physiology. The Botanical Periodicals proceed in the usual manner; some of them improve, particularly Maund's *Botanist*. That excellent work, Baxter's *British Flowering Plants*, is advancing into the fifth volume; and the no less excellent one, Sowerby's *English Botany*, is in the eighth volume, having finished the ferns and commenced the mosses. A gardener's newspaper, the *Old England and Gardener's Journal*, was commenced in the course of the year, but soon dropped. The horticultural department of the *Gardener's Gazette* has been put under our direction, commencing with the number for November 14.; but this will make no difference to the *Gardener's Magazine*, which our readers may rest assured will be continued and conducted by us as long as we shall live. See our address in the *Gardener's Gazette*, for 1840, p. 724.

Education.—This subject, which ten years ago we were found fault with for mentioning at all in the *Gardener's Magazine*, is now making steady progress, and those who were formerly its greatest enemies are beginning to become its friends; finding from experience that persons without this inestimable blessing are liable to be blown about by "every wind of doctrine," and thus to become the most dangerous enemies of civilised society. Our opinion is, as expressed in our earlier volumes, both of this periodical and of the *Magazine of Natural History*, that the progress of education will not be complete till it ends in "all useful knowledge being taught to all;" which it may be, by means of infant and other schools, and workshops, to every individual, male and female, before reaching the age of 16 years. Our words were, that, "supposing education to be a fluid, every individual ought to be immersed in it, in order that he may absorb as much as his organisation will admit." The result will be, that every individual will be in the same relative situation to every other individual that he is at present; but that all will have their capacities for enjoyment greatly increased, and all will be incomparably happier; inasmuch as knowledge is a source of pleasure, as well as of power. The idea, that, if common labourers were educated to a higher degree than they are at present, there would be "no such thing as getting servants," is a bugbear that is vanishing like the idea of ghosts and spectres.

Garden and Rural Improvement in Foreign Countries.—France has advanced both in the culture of flowers and fruits, and more especially in the culture of the pine-apple, as will appear by our Notes made during a visit to Paris and Fontainebleau in July and August last, which will be given in our ensuing volume.

We have heard little, during the year, of gardening improvements going forward in Germany, except that a public garden has been formed at Hamburg at the expense of the town, and for the benefit of all the inhabitants. In Berlin, a new Botanical Periodical has been commenced, of which a notice will be found in p. 566. Great progress in gardening has been made in Russia, especially in the neighbourhood of Moscow (see p. 565.); and ample accounts of the state of vegetable culture in Egypt will be found in p. 645., and of North America in p. 642.

Obituary.—The botanical and gardening worlds have lost in the course of the year, Baron Jacquin, Allan Cunningham, and Charles Sckell of Munich; the last an eminent landscape-gardener.

ART. I. *Report on the new Species and Varieties of hardy Trees and Shrubs raised in the Horticultural Society's Gardens since the last Report, made in November, 1839, and published in the "Gardener's Magazine" for 1840, p. 1.* Drawn up for the "Gardener's Magazine" by Mr. GORDON, of the Arboretum of the Horticultural Society, by Permission of the Council of that Body.

RANUNCULA'CEÆ.—*Atrágene macropétala* Ledebour's MS. This seems a distinct species, and very little known, as I have not been able to find any published account of it. It is, however, certainly a species of *Atrágene*, and comes nearest to *A. alpina*, and, like that species, is quite hardy. I have only succeeded in raising a single plant from a small paper of seed, presented to the Society by Dr. Bunge of Dorpat. The plant is a native of Siberia, and is said to have large white flowers, probably the *Clématis sibírica flore albo* of the Hamburg collections.

BERBERA'CEÆ.—*Bérberis* (*Mahònia* sp. *Arb. Brit.*) *trifoliàta* Hartweg's MS. This beautiful and very distinct species was raised from seeds received from M. Hartweg, who found it growing at a place called San Luis Potosi, in Mexico, covering large tracts of land, and almost the only flowering shrub in that place, which was not eaten by the all-devouring goats. It is very curious in having the leaves always in threes, and in showing the approach of the pinnate to the single-leaved species. It is probably about as hardy as *B. [M.] fasciculàris*, which its small yellowish green prickly leaves resemble; but the fruit is of a yellowish green colour when ripe.

Bérberis (*Mahònia* sp. *Arb. Brit.*) *pállida* Hartweg's MS. *Benth. Plantæ. Hartw.*, p. 34. No. 268. This is another of the beautiful pinnate berberies found in Mexico by Hartweg, who sent home to the Society a small portion of the seeds, and from which a single plant only has been raised. It resembles *B. [M.] Aquifòlium*; but the leaflets are not so spiny, much smaller, and from 11 to 15 in number. The flowers are of a whitish colour (hence the name). The plant grows from 6 ft. to 8 ft. high, and was found at a place called Tula, and also at Atotonilco el Grande, and San Jose del Ora, near Zacualtipan in Mexico.

Bérberis (*Mahònia* sp. *Arb. Brit.*) *grácilis* Hartw. MS. *Benth. Pl. Hartw.*, No. 271. This also is another very distinct species of *Bérberis*, with not more than 4 pairs of leaflets, but of the *B. [M.] Aquifòlium* section, and but slightly toothed. It was found by M. Hartweg growing about 6 ft. high, at a place called Zimapan in Mexico; and, like the preceding, he only found a very small portion of ripe seeds, and from which only a single plant has been raised in the garden.

It may be here worth recording, for the benefit of those who have correspondents in Mexico, that the following *three* species were found by M. Hartweg, who was unable to procure any ripe seeds at the time, and are fully described by Mr. Bentham in his valuable *Plantæ Hartwegianæ*, p. 34., from dried specimens sent home by M. Hartweg. These make no less than *seven* new pinnate species of (*Mahònia*) berberries found by him in Mexico.

Bérberis (*Mahònia* sp. *Arb. Brit.*) *lanceolatum* Benth. *Pl. Hartw.*, p. 34. No. 269. This is the handsomest of all the Mexican species yet known, and very distinct. It has the long slender leaves of *B.* [M.] *tenuifolium*, but the leaflets are very spiny, dark green, and there are from 13 to 17 leaflets on each leaf. The plant grows from 5 ft. to 6 ft. high, and was found by M. Hartweg on the mountains of Apulco in Mexico, and at the Contaders between Tula and St. Barbara, flowering in April. It would be a great addition to the beautiful pinnate species if introduced, and probably is quite hardy.

Bérberis (*Mahònia* sp. *Arb. Brit.*) *angustifolia* Hartw. MS. *Benth. Pl. Hartw.*, No. 270. Another very distinct but small species in the way of *B.* [M.] *fascicularis*, but very much smaller in all its parts; with from 5 to 7 leaflets on each leaf, which are very spiny, and of a light green colour. It was found by M. Hartweg at a place called Pachuca, near Actopan in Mexico, growing 6 or 8 feet high, with purple fruit, which is said to be very sweet. It still remains to be introduced.

Bérberis (*Mahònia* sp. *Arb. Brit.*) *Hartwegii* Benth. *Pl. Hartw.*, No. 272. This has the largest and finest foliage of all the Mexican species as yet known; the leaves are very large, having from 11 to 15 leaflets, which are nearly double the size of those of *B.* [M.] *Aquifolium*, and of a bright green colour, much resembling that species. It also remains to be introduced. M. Hartweg found it at a place called Tula and at Santa Barbara in Mexico, flowering in April.

ACERACEÆ. — *Acer levigatum* Wall. *Arb. Brit.*, p. 431. A very distinct species of *Acer*, belonging to the same section as the beautiful, but certainly tender, *A. oblongum* of Dr. Wallich, but differing from that species in having the leaves numerous and deeply serrulated, of a dark shining green, and in not being glaucous on the under side. It is found on the loftiest mountains of Nepal, growing about 40 ft. high; and, according to Dr. Wallich, will be quite hardy. It was raised in the garden of the Society, from seeds received from Dr. Royle.

Acer colchicum Booth MS. This is a very handsome and distinct maple, more like *A.* [*p.*] *Lobëlii* than any other species that I am acquainted with; but differing from it in having the lobes of the leaves more pointed, the bottom lobes lapping over the footstalk, and in being mucronate. The leaves are also five-lobed, of a bright glaucous green, and not quite so large as those of *A.* [*p.*] *Lobëlii*. It was received from Messrs. Booth of Hamburg, under the above names; but I have not been able to find any such name published, nor is any such name to be found in their catalogue. I suppose the plant must be from Colchis in Asia, but it is quite new to me.

RUTAACEÆ. — *Ruta [gravæolens] angustifolia* Persoon. *Arb. Brit.*, p. 487. fig. 156. This is nothing more than a narrow-leaved variety of the *Ruta gravæolens*; the leaves are much more glaucous, very narrow, and the plant altogether is distinct, being intermediate between *R. gravæolens* and *R. montana*. The plant is as hardy as *R. gravæolens*, and much stronger-scented. There seems some confusion about *R.* [*g.*] *chalapense*, which is only another variety of the common *rues*, as well as *R.* [*g.*] *montana*.

RHAMNACEÆ. — *Rhamnus* Wicklius Jacquin. This species belongs to the same section as *R. infectorius* and *R. catharticus*. It was raised from seeds received from Dr. Fischer, and seems tolerably distinct from *R. infectorius*, having larger leaves. The plant is quite hardy.

ANACARDIACEÆ. — *Duvaia longifolia*. This very distinct species has long bright green leaves, and belongs to the same section as *Duvaia latifolia* Lindl. *Bot. Reg.* t. 1580. It was raised at the Clapton Nursery, from seeds col-

lected in Chili, and a plant was given to the Society by Mr. H. Low. This plant is hardier than any other of the genus *Duvaúa*.

LEGUMINOSÆ. — *Sophora* [*japónica*] *pubescens* Booth. This certainly is only a variety of *S. japónica* with the leaves a little more pubescent. It was received from Messrs. Booth of Hamburg, and is not very distinct.

Genista ephedroides Dec. *Arb. Brit.*, p. 580. This neat slender species was received from the Birmingham Botanic Garden, and bears some resemblance to the old *Genista* (or *Spártium*) *monosperma*. It has yellow flowers, is hardy, and a native of Sardinia.

Caragana Gerardiana Royle. A very distinct species, raised from seeds presented to the Society by Dr. Royle, who has published a figure of it in his beautiful *Illustrations of the Himalayan Mountains*, where he also gives the account of its being the Tartaric furze so frequently mentioned by travellers, and found at very high elevations at Sirmore by Dr. Gerard, and at the Neetee Pass, by Captain Webb, at an elevation of upwards of 16,000 ft. It is curious in having nearly all the leaves terminated by a spine, and, when the leaflets fall off, the remainder becomes a permanent spinosity.

Astrágalus fruticosus Dec. This scarce little undershrub was raised from seeds received from the late Baron Jacquin, and is quite hardy, but only fit for planting on rockwork, or to be kept in pots, as the superabundant moisture of autumn and winter soon destroys them.

This species and the following one belong to the smooth shrubby or *Onobrychis* section, and not the prickly or *Tragacanth* section.

Astrágalus vimineus Dec. Another very pretty little shrubby species of milk vetch, which was given to the Society by Messrs. Lee of Hammersmith, and, like the last, only fit to plant in a dry situation, as they always suffer from the extremes of wet and dry, and like most of the shrubby Siberian Leguminosæ, although subject to a severe winter, are rather difficult to keep long alive except in pots.

ROSACEÆ. — *Amýgdalus Pallásii*. This is the *A. pedunculata* of Pallas, which was raised from seeds received from Dr. Ledebour three or four years ago by the Society. It is a very pretty dwarf decumbent bush, and quite hardy. The name *pedunculata* is the oldest and the one mostly adopted by Continental botanists, and the name, I believe, first given to the plant by Pallas.

Spiræa fissa Lindl. *Bot. Reg. Misc.*, No. 170. 1840. This beautiful species was raised from seeds received from the Society's collector in Mexico. It very much resembles *S. arizæfolia* (with which it forms a distinct section), but differs from that species in having the leaves much smaller, bright green, quite smooth on the upper surface, and in having the lateral lobes split or incise. M. Hartweg, who found it, says that it grows from 15 ft. to 20 ft. high, will prove quite hardy, and rivals the beautiful *S. arizæfolia* of North-West America. He does not mention where it was found, but it probably grows on the mountains of Anganguco in Mexico.

Spiræa Reevesii. A plant of this very distinct species was presented to the Society by Mr. Knight, F.H.S., of the King's Road, Chelsea. It is quite distinct from any other *Spiræa* that I am acquainted with, in having long, lanceolate, attenuated, glabrous, leathery leaves, and in being nearly evergreen. The leaves are mostly much jagged or deeply serrated, but sometimes they are 3-lobed and quite smooth. The plant is hardy, and was introduced by Mr. Reeves from Japan, who presented the first plant to Mr. Knight: the name placed above will indicate to whom the merit of introducing the plant is due, for to no person are we so much indebted as to John Reeves, Esq., F.H.S., of Clapham, for so many beautiful plants both from China and Japan.

Spiræa rotundifolia Lindl. *Bot. Reg. Miscel.*, No. 159. 1840. Another new species which comes nearest to the *Spiræa cuneifolia* of my former Report for 1839, p. 3., but differs from that species in the leaves being quite round and large. It was raised from Cashmere seeds collected by Dr. Falconer, and presented to the Society by Dr. Royle, to whom the Society

is so much indebted for the seeds from which so many new plants have been raised, natives of the Himalaya, and other northern parts of India.

Petromëlis ovàlis subcordàta Jacquin. Baron Jacquin has changed the genus *Amelanchier* into *Petromëlis* [see *Selectis Seminum pro Commutatione*, &c. 1837]; and this plant is identical with *Amelanchier ovàlis subcordàta* *Arb. Brit.* p. 876. The account given of it by Dr. Richardson is, that it is found on the sandy plains of the Saskatchewan, and its berries are about the size of a pea, are the finest fruit in the country, and are used by the Crees, both fresh and dried. They make a pleasant addition to pemmican, as well as excellent puddings very little inferior to plum-pudding.

Pyrus heterophýlla Booth. A very curious and distinct plant raised from seeds received from Dalmatia, and also a plant was given to the Society by Messrs. Booth. The leaves are about the size of the common hawthorn, and of the same shape, but finely serrated on the edges and glabrous: they vary from 3- to 5-lobed. It is very distinct from any other at present known, and I can find no account except the name in Messrs. Booth's *Catalogue*.

PHILADELPHA'CEÆ. — *Philadélphus mexicanus* Benth., *Pl. Hartw.*, p. 61. No. 458. This is about one of the smallest of the species at present known, with very much of the habit of *P. láxus*, but the leaves are nearly entire, and rather smaller, but, like that species, the flowers are mostly solitary, rather large, and scentless. It was raised in the garden of the Society from seeds received from M. Hartweg, who found it at a place called Hacienda del Carmen, in Mexico. It is hardy, and forms a graceful little bush.

GROSSULA'CEÆ. — *Ribes taúricum* Jacquin. This is certainly nothing but a mere variety of *R. petræum*. It was raised in the garden from seeds received from Baron Jacquin.

ARALIA'CEÆ. — *Aràlia japonica* Sieboldt. This is a very fine hardy species of *Aràlia*, very much like the *Aràlia spinòsa* of North America, but differing from that species in having the leaflets much smaller, sessile, and the flowers in rather flat panicles, and not umbellate as in *A. spinòsa*. The plant was presented to the Society by Mr. Low of Clapton.

CORNA'CEÆ. — *Córnus grándis* Benth. *Pl. Hartw.*, p. 38. No. 298. A beautiful species of dogwood raised from seeds received from M. Hartweg, who found it on the ravines near Chico in Mexico, forming a small tree; but it is uncertain whether it is hardy or not. The plant most resembles *C. sericea*, but with the leaves from 3 in. to 5 in. long, smooth and deep green above, and hoary with down on the under side. The fruit is about the size of the common sloe, and purplish black. The flowers are in small heads, and not very conspicuous.

Córnus macrophýlla Wall. Plants of this fine species of dogwood were raised in the garden from seeds received from Dr. Royle, who gives the following account of it in his *Illustrations*. He says "it is found growing at the Mussoree and similar heights along with *Benthàmia fragífera*;" and Dr. Wallich gives it a still greater range, as he found it at Saharunpore, Sirinagur, and at Kamoon. Still I fear it will not be much hardier than *Benthàmia*, but will make a beautiful sub-evergreen shrub or small tree, and is sure to succeed well where *Benthàmia* will. Dr. Royle says it is a very elegant plant. It is more like *C. sericea* than any other I know, with leaves 6 in. long and 2½ in. broad.

ERICA'CEÆ. — *Arctostáphylos púngens* H. & B. *Nova Gen.*, vol. iii. p. 278. t. 259. This very singular species of *Arbutus* has small greyish entire lanceolate leaves. The plant is nearly prostrate and quite hardy. It was raised from seeds transmitted by M. Hartweg, who found the plant at Guanaxuato in Mexico, and of which a large quantity of the seeds were distributed by the Society.

Pernéttya angustifolia Lindl. *Bot. Reg.*, t. 63. 1840. This very distinct species was received from Mr. Cunningham of Edinburgh, and also from Mr. Cameron of Birmingham. It has longer and narrower leaves than any other species of *Pernéttya* that I am acquainted with. It is a native of Chili and

as hardy as the other species of the pretty genus to which it belongs. It is known in some collections under the names of *P. myrtifolia* and *P. philly-reæfolia*.

ASCLEPIA DEÆ. — *Morrèna odorata* Lindl. This curious plant has proved as hardy as the *Physiánthus álbens*, which it very much resembles; but differs in having much larger cordate leaves and smaller flowers, as well as in the botanical structure. The flowers are white, sweet-scented, and solitary. I have never seen the fruit.

SCROPHULARIA CEÆ. — *Paulòwnia imperiális* Sieboldt. *Flor. Jap.*, p. 27. t. 10. A plant of this beautiful tree was raised in the garden of the Society from seeds received from Japan in 1338. It has large cordate leaves very much like those of the *Catálpa syringæfolia* of North America, with which it was considered identical by Thunberg; but Dr. Sieboldt, who had an opportunity of fully examining it, has formed the plant into a new genus under the above name. The plant is quite hardy.

THYMELA CEÆ. — *Dáphne Aucklandii* Lindl. This fine species of *Dáphne* belongs to the same section as *Dáphne alpina* with smooth lanceolate leaves. It is evergreen, and was raised from seeds sent to the Society by Lord Auckland from Kunawur, where it was found at an elevation of 12,000 ft., and near the limits of perpetual snow. There is no such plant described by Dr. Royle in his beautiful *Illustrations of Northern India*, nor does it appear that the plant was known to Dr. Wallich; but the *Dáphne viridiflora* of Wallich, and the *D. mucronata* of Royle, belong to the same section as *D. Aucklandii* of Lindl.

ULMA CEÆ. — *Spònia canéscens*, syn. *Céltis canéscens* H. & B. This species of the old genus *Céltis* was raised from seeds received from M. Hartweg, who found it near Angancuco in Mexico: he says it will prove hardy. It very much resembles in its present state *C. australis*, but is more downy, and particularly so on the under side of the leaves.

BETULA CEÆ. — *Ahnus jorulensis* Benth. *Pl. Hart.*, p. 52. No. 392. This very distinct species of alder was raised from seeds transmitted to the Society by M. Hartweg, who collected them at a place called Zacualtipan in Mexico, but the plant is common on the mountains of Jorula, and on the mountains between the city of Mexico and Tampico. It much resembles *Ahnus serrulata*, but the leaves are 6 in. long and 3½ in. broad, and, like all the others of the genus no doubt will prove quite hardy. M. Hartweg considered it a species of *Bétula*, and a large quantity of the seeds received from M. Hartweg was distributed by the Society under that name; but it is certainly a true species of alder, and not a birch.

Bétula mollis Lindl. *Bot. Reg. Mis.*, No. 169. for 1840. This singular species of birch was raised from seeds collected in the Himalaya Mountains by Dr. Falconer of the Saharunpore Botanic Garden. It is remarkable for the softness of its leaves, which are roundly heart-shaped, and seems nearly related to the *Bétula álba pubéscens* *Arb. Brit.*

Bétula Bhojpúttra Wallich. *Arb. Brit.*, p. 1714. The finest of the Himalayan species of birch, and certainly the most desirable. It was raised in the garden of the Society from seeds, for which we are indebted to the Hon. the Court of Directors of the East India Company. According to Dr. Royle, this species occupies the loftiest mountains in the Himalayas, and the following account is given of it in the *Botanical Register* for Oct. 1840, by Dr. Lindley. "The epidermis of the *Bétula Bhojpúttra* is used by the mountaineers instead of paper for writing upon; it is of a very delicate texture, and peels off in large masses, of which great quantities are brought down into the plains of Hindustan, where it is employed for covering the inside of the long flexible tubes of the apparatus used for smoking tobacco, commonly called hooka. The Sanscrita name of the substance is Bhoorja, in the Bengali language Bhoorjapattra; and Mr. Graves Haughton, Oriental Examiner to the Hon. East India Company, is of opinion that the word Bhoorja is the etymon of Birch. It belongs to the same section as the paper birch of America and very much resembles the *B. papyracea*."

CORYLACEÆ.—*Quercus reticulata* Humb. et Bonp. *Arb. Brit.*, p. 1941. fig. 1865. ; *Bot. Reg. Miscel.*, No. 161. 1840. The leaves of this species are not much above half the size of those of *Q. spicata*, but very much of the same shape, except that they are not so blunt, slightly dentated, with longer mucros, and less undulated. They are very much reticulated on the under surface, rather glaucous, and quite smooth on both surfaces; the acorns are rather small. It was raised from seeds received from Mr. Strangways collected at Real del Monte in Mexico.

Quercus sideroxylla Humb. et Bonp. *Arb. Brit.*, p. 1941. fig. 1860. ; *Bot. Reg. Miscel.*, No. 166. 1840. This distinct species has rather small lobulate, unequally dentated, undulated, dark shining leaves, with the mucros hardly perceptible. They are smooth on both surfaces, and the acorns are very small. I have raised three tolerably distinct sorts, varying mostly in the size of the leaves only, but they are certainly nothing but varieties of the iron oak; and I fear that one half of the Mexican oaks described in books are species made out of specimens collected from old and young plants of the same species, or from plants grown in damp rich soil in the warm valley, or poor stunted specimens grown high up on the mountains. The difference between young and old plants is so great that I do not think any botanist would credit it, unless they were to gather the seeds and raise the young plants themselves. *Q. sideroxylla* was raised from seeds given to the Society by Mr. Strangways, and is said to be one of the hardiest of the Mexican oaks.

Quercus acutifolia Willd. *Arb. Brit.*, p. 1941. fig. 1874. ; *Bot. Reg. Miscel.*, No. 160. 1840. This distinct species has rather large, glabrous, and widely serrated mucronate leaves, each lateral rib terminating in a rather long slender mucro. The leaves are quite smooth on both surfaces, and of a bright shining green. The acorns are very large, flat, and very much depressed. It probably belongs to [the same section as *Q. Prinos* or *Castanea*. It was raised from seeds sent to the Society by M. Hartweg, and the acorns were thrown loose into a box of *Orchideæ*, packed in moss, which gives an excellent hint as to the best way of transmitting acorns on long journeys; as packing them in moss is decidedly the best way of transmitting such seeds as soon lose their vitality, but they must not be by any means in small cases.

Quercus spicata Humb. et Bonp. *Arb. Brit.*, p. 1941. fig. 1867. ; *Bot. Reg. Miscel.*, No. 163. 1840. This very fine oak has large, broad, obovate leaves, in some tapering very much towards the base, in others nearly round, which are rather crenulated, or in some nearly entire; but regularly undulated at the margin, and having very short but broad mucros. The upper surface is quite smooth; but the under surface, particularly the mid and lateral ribs, is covered with a dense brown tomentum, and is beautifully reticulated. The leaves are nearly sessile, and the acorns are rather small. This species belongs to the same division as *Q. lanuginosa* (which is known under the name of *Q. nepalensis* in some collections). It was raised in the garden of the Society from acorns presented by the Hon. W. F. Strangways. The plant was also found by M. Hartweg at a place called Tlalpuxahua, in Mexico. It is the same as that extant in some of the London nurseries under the name of *Q. rugosa*. It is also very nearly related to *Q. Hartwegii* of Mr. Benth.

Quercus glabræscens Benth. *Pl. Hartw.*, No. 428.—This beautiful small-leaved species is well described by Mr. Benth in his excellent *Plantæ Hartwegianæ*, as above quoted. It has the leaves deltoid, slightly undulated (particularly in the young ones), with the extreme ends rather deeply serrated, but without mucros: they are quite glabrous on both surfaces; but the young wood, like that of most of all the other oaks, is covered with a dense tomentum, and furnished with rather long stipules, which both disappear after the first season, and show how little reliance is to be placed on such fugacious appendages. The leaves and acorns are the smallest of all the Mexican oaks belonging to the lobulated division at present known. The acorns were given to the Society by Mr. Strangways, and M. Hartweg found the same species at Real del Monte.

Quercus petiolaris Benth. *Pl. Hartw.*, No. 420.— This species has the leaves in the young plants so many different shapes that it would be useless attempting to describe them, as in some they are much serrated and obtuse, in others angulated and pointed, in others again slightly crenated and undulated; while in the leaves of the old plants they are quite entire, on very long foot-stalks, and resembling some of the fine varieties of *Q. Ilex*, but they are rather larger, rounder, and not so thick. They are quite glabrous, but rather glaucous on the under side; the petioles vary very much even in the old specimens, for they are very long in some, and quite sessile in others. The acorns are about the size of those of *Q. Ilex*, and were received from M. Hartweg, who found the tree at a place called Bolanos, in Mexico.

Quercus crásipes Humb. et Bonp. *Arb. Brit.*, p. 1941. fig. 1862.; *Bot. Reg. Miscel.*, No. 162. 1840.— This pretty species belongs to the same division as the *Q. Phellos* and *Q. mexicana*, which latter it very much resembles, but the leaves are more linear, and not nearly so large; and have only a very short tomentum on the mid-ribs on the under side. The seeds were received from Real del Monte.

Quercus lancifolia Bot. Reg. Miscel. No. 167. 1840. This beautiful holly-like oak has the leaves various-shaped, but always pointed. It belongs to the Viréntes division (or live oak), and is very much like *Q. virens* of North America, but the leaves are not so broad, and much longer. It is from Mexico, and a plant was presented to the Society by Mr. H. Low of Clapton, along with a plant of the true *Quercus mexicana*. It was found near Real del Monte, but is rather scarce there.

Quercus annulata Smith and Wallich. *Arb. Brit.*, p. 1921. fig. 1805. Plants of this species have been sent by Dr. Wallich to several collections. It is one of the thin-leaved oaks of Nepal, with smooth widely serrated leaves when young, but probably nearly entire on the old trees. The acorns are rather small, and two thirds buried in the cup. This seems very nearly related to *Q. acuminata* of ? Wallich, and is probably the same.

Quercus pannonica Booth. This seems rather distinct, but certainly belongs to the same set as *Q. Taurin*, which it very much resembles. It is said to have been found on the Count Josikea's estate in Hungary, at the same place where the beautiful *Syringa Josikæa* was discovered. It was received from Messrs. Booth of Hamburg.

Quercus rubra var. *taraxacifolia* Booth. This singular variety of the common American red oak has long, narrow, irregularly-lobed leaves. It was received from Messrs. Booth.

GARRYA CEE.—*Garrya laurifolia* Hartw. Only a single plant of this beautiful species has been raised in the garden of the Society, and I am not aware that any other person has succeeded with them, although several hundred papers of the seeds were distributed by the Society. The seeds, to all appearance, were in excellent condition, and quite fresh. It has leaves about the size and shape of the largest leaves of the sweet bay, but pubescent on the under side in the adult leaves, and on both sides in the young ones. It was found by M. Hartweg in the mountains of Mexico, near Guanajuato, a shrub from 15 ft. to 18 ft. high; and at Anganguco it formed a tree with a trunk 2 ft. in diameter. M. Hartweg has also found four other new species of this curious genus in Mexico, but was unable to send seeds in a living state, but of which he has sent excellent dried specimens: and, as it may be interesting to those who have friends or correspondents in Mexico to know where to find the other four species, I give the following accounts of the plants and their localities; and for any further particulars the reader is referred to the following quotation from Mr. Benthams's valuable *Plantæ Hartwegianæ*:—

“Leaves elliptic oblong, very entire, or minutely dentate. Flowers in both sexes solitary, opposite, sessile; one seated in every bract, and shorter. The stamens in *G. laurifolia* and *G. ovata*, and apparently in *G. elliptica*, are opposite to the laciniae of the perigonium.

"A plant found amongst the precipices of Barranca del Encarnacion near Zimapan was sent home by Hartweg as a distinct species, under the name of *Garrya Lindleyi*; but, judging from a few withered specimens, of which one was in fruit, there appears to be no difference between it and *G. laurifolia*." This is Mr. Bentham's opinion; but Mr. Gordon "thinks the two kinds quite distinct. Hartweg," he says, "who found both, and named them, was not likely to be mistaken; and I find, by comparing the specimens sent along with the seeds, that they are very distinct, one being quite glabrous, on both sides of the leaves, while the other has the leaves downy on the under side, and nearly double the size."

Garrya macrophylla Hartweg. *Benth. Plantæ Hartw.*, p. 50. This has nearly round leaves, somewhat resembling the common wayfaring tree (*Viburnum Lantana*), but two or three times as large, with the upper surface smooth, and the under covered with a dense pubescence. It forms a small tree, and was found by M. Hartweg in the Barranca del Encarnacion near Zimapan in Mexico. This is the finest of all the *garryas* at present known, and very well worth the trouble of endeavouring to introduce, and one that would soon repay any person who has got correspondents in Mexico. Mr. Bentham's spec. char. and description are as follows:—

"Leaves large, broadly ovate-elliptic; the younger cobwebbed above, woolly beneath; the full-grown blistered, smooth, and shining above, woolly or become smooth beneath. Racemes short, disposed in a dense few-flowered panicle. Flowers (of both sexes?) solitary, sessile, one seated in every bract. I have seen but two specimens— one, male and withered; the other, female and in fruit. Leaves $3\frac{1}{2}$ in. to 4 in. long; 2 in. to $2\frac{1}{2}$ in. broad. Fruit scarcely larger than a grain of pepper. Barranca del Encarnacion, near Zimapan."

Garrya oblonga Benth. *Pl. Hartweg.*, p. 51. No. 385. This is one with very small leaves, very much resembling the smallest leaves on the *Quercus Ilex*. They are about $1\frac{1}{2}$ in. long, and about $\frac{1}{4}$ in. broad, quite smooth above, and downy on the under side. The plant grows about 6 or 8 feet high, and was found by M. Hartweg on the sandstone hills near Regla. Mr. Bentham's spec. char. is as follows:—

"Leaves oblong-lanceolate, or oblong elliptic, mucronate, or rarely sub-mutic; the younger loosely tomentose beneath, or on both sides; the full-grown smooth and shining above, tomentose or become smooth beneath. Racemes short. Flowers The specimens are few and withered. Shrub 6 ft. to 10 ft. high."

Garrya ovata Benth. *Pl. Hartw.*, p. 14. No. 80. This species has rather small round leaves, about the size of those of the common plum; quite smooth on the upper surface, but very downy on the under surface. It was found growing on rocks at 9,000 ft. in the mountains of Bufa, near Guanaxnato, by M. Hartweg, forming a bush 4 or 5 feet high. It is more like *Garrya elliptica* of Douglas than any of the others, but the leaves are not half the size.

"Leaves ovate, very entire, sub-mucronate, densely pubescent beneath. Flowers, male in short racemes; and in both sexes solitary, sub-sessile; one seated in every bract, and exceeding it in length. *Benth.*"

CONIFERÆ.—*Pinus pithyusa* Strangways. This is only one of the varieties of *P. halepensis*, and is, I believe, identically the same as *P. maritima* of Lambert's *Monograph*, *P. halepensis maritima Arb. Brit.*, p. 223. fig. 2112., which is only the largest-coned variety, and more egg-shaped than the cones of the true Aleppo one. I have raised it from a cone presented to the Society by Mr. Strangways, and Messrs. Booth of Hamburg have also presented the Society with a plant.

Pinus pátula var. fólis strictis Bentham. *Plant. Hartw.* This pine is considered by Mr. Bentham as only a variety of *P. pátula Arb. Brit.*, p. 2267., but it certainly is a very distinct one. The leaves of this (? species, not variety) are three in a sheath, 7 or 8 inches long, stiff, and three times the size of those

of the true *P. pátula* of my former report (p. 6.), the leaves of which are only five inches long, and very lax. The cones are hard, horn-shaped, and like those of *P. pátula*, but much smaller: they were received from M. Hartweg, who found them at Real del Monte in Mexico.

Pinus Ayacahuíte Schiede. This gigantic pine belongs to the *Stròbus* division, with the leaves five in a sheath, very short, not being more than 3 or 4 inches long, but rather stout for the leaves of this section: the sheaths are deciduous, and the leaves (particularly the young ones) are glaucous on the under side. The cones very much resemble those of *P. excélsa*, but are three times the size, being from 12 in. to 18 in. long, with distant, oblong, lanceolate, obtuse, spreading scales, which are reflexed at the points. It was found by M. Hartweg on the mountains of Guatemala, and by M. Ehrenberg at Omitlan in Mexico.

Pinus filifòlia Lindl. *Bot. Reg. Miscel.*, p. 132. 1840. This magnificent new pine has the leaves five in a sheath, which are from 15 in. to 18 in. long, and are longer than in any other species previously discovered. The branches are stouter than those of *P. austràlis*, and the cones also resemble those of that species more than any others that I am acquainted with, being from 7 in. to 9 in. long, tapering to a point, and with rather prominent scales. It was raised from seeds collected by M. Hartweg, on the Volcan del Fuego, in Guatemala.

Abies Smithiana Wallich. *Arb. Brit.*, p. 2317. fig. 2229. This Indian fir has been very much confused, and is supposed by some to be the same as *Abies Morinda* (also *Khùtrow*) of Royle, but they are very distinct in the cones; cones of the true *A. Smithiana* having been sent to the Society by Dr. Wallich, and of *A. Morinda* (*Khùtrow*), by Dr. Royle. The cones of *Abies Smithiana* are not half the size of those of *Abies Morinda*, but more conical, with the scales rather cuneated, and much divided at the margins; while those of *Abies Morinda* (*Khùtrow*) are bluntly oblong, with the scales rounded, nearly entire (mostly bilobed), much thicker and larger in proportion. I have not been able to detect any difference in the leaves of the young plants, but the young seedlings of *Abies Smithiana* are much slenderer and smaller than those of *Abies Morinda* of the same age. The tree in the Horticultural Society's Garden, of which a portrait is given in *Arb. Brit.*, vol. viii. t. 340., is *A. Smithiana* Wall.

Picea Pinsàpo Bois. This most certainly is nothing but a slight variety of *P. cephalónica*, but, I believe, distinct in some minor points; and I am surprised how any person with the least possible knowledge of *Coniferae* should have supposed the one to be a *Picea* and the other an *Abies*. The seeds of *Abies* are hard-shelled and round, like those of *Pinus*, while the seeds of *Picea* are soft and angular. This alone is quite sufficient to decide the generic difference, without even having the deciduous scales of the cones.

Juniperus flagelliformis. A plant of this very distinct species of juniper was presented to the Society by Mr. Reeves, in the shape of one of those deformed, or rather decrepit, specimens of Chinese skill, an old pollard, which is said to be above one thousand years old. It is very distinct from any other that I know or can find any description of. It has long, slender, closely imbricated shoots (both young and old), very much resembling very fine whipcord (in consequence of which I have placed the above specific name provisionally), and it is a true juniper, having sometimes those open glaucous shoots with sharp lanceolate leaves. The fruit is small, globular, but sometimes slightly angular, and very glaucous. It is quite hardy, and strikes freely from cuttings of the two-years-old wood. [Being quite hardy, and so easily propagated, we trust so interesting and ornamental a species will soon become general in collections. We recommend the plant to nurserymen.]

Juniperus dealbata. This very distinct and handsome species is supposed to be from North-West America. It has the close habit of the common juniper, but with small, imbricated, sharp-pointed leaves, rather distant on the shoots, which are rather slender, and of a beautiful glaucous colour, more particularly in the early part of summer. It is very distinct from any others

that I know, and is one of the strongest-scented, not even excepting the savins. It is quite hardy, and forms a rival for the singular *J. suécica* in habit.
Horticultural Society's Garden, Nov. 14. 1840.

ART. II. *On Mr. Penn's Mode of Warming and Ventilating.*
 By N. M. T.

AFTER visiting Mr. Penn's establishment with the view of ascertaining the merits of his method of heating and ventilating plant-houses, the result is that I think it fully deserving of all that you have said in its favour. I consider, it the greatest boon ever conferred upon the horticulturist. To Mr. Penn the thanks of every gardener are justly due; mine he has most sincerely; as I consider that he has done much to lessen the labour of our profession; to shorten the list of countless accidents that were ever ready, even at the eleventh hour, to deprive us of the just reward for months of unremitting exertion and anxiety; and to render, with ordinary care, success, even in our most difficult operations, almost a matter of certainty. Were it merely a matter of theory, the advantage of a free circulation over stagnation, for every purpose of the cultivator, must be obvious to every person possessing common sense, however destitute he might be of horticultural knowledge; but happily this system has been so far tested by practice, that there is not room for a single doubt of its effects. The plants treated according to this system by Mr. Penn are such, that I am satisfied he need only show them to his most decided opponents, to convince them of the utter hopelessness of all opposition, and that his system must speedily supersede all others. The beholder is in fact forced into the most favourable conclusion, without the aid of judgment; as nothing can more forcibly appeal to the senses. Its effects may be tasted, smelled, and they are as sensible to feeling as to sight. The exquisite flavour of fruit, the unusual degree of fragrance in flowers, the entire absence of all confined or fetid smells, and the comparative ease with which we can bear a degree of temperature that under ordinary circumstances soon becomes intolerable, may all be appreciated by the merest novice. The practised eye of the connoisseur and the practical man must perceive a striking originality of character displayed by every plant that comes under his notice in Mr. Penn's houses. This change of habit must be seen to be fully understood. Still there is no doubt that the effect greatly depends upon the unparalleled breadth of fine foliage so universally displayed; and upon the absence of all debility of habit, which is more or less apparent in every plant cultivated in the hitherto unnatural atmosphere created by a covering of glass. There is a truly remarkable difference in this respect between some plants of the species flowering with Mr. Penn, and flowering in some of the superb collections in the neighbourhood of London. The flower stems produced in the confinement, and by the excessive stimulus applied by the latter, are elongated, comparatively feeble, and half-pendent from the weight of their blossoms; while with the former they are stubby, elastic, and upright, bearing with ease their fine blossoms, having apparently found the necessity of nerving themselves to withstand the current of air in which they live.

It would be tedious to descend to the notice of individual species, but in remarking the superiority over general culture so evident, I paid particular attention to such of our old shy favourites as fell in my way; and notwithstanding their general obstinacy, I invariably found them keeping pace with (or rather surpassing) the mass in their approach to perfection.

Some cucumbers trained up the rafters of a forcing-house were growing with surprising luxuriance, and under them kidneybeans in pots in full bearing, and exhibiting (June 1.) all the health and stubbiness they generally do in March or April. Let the practical man mark this. A house of pine plants, without a single exception, of the most magnificent growth, demands a

separate notice. In examining some pine plants grown in pits of the ordinary construction, I was delighted to find them also growing after the ordinary manner. This speaks forcibly for the system, and demonstrates that any extraordinary effect may be attributed to Mr. Penn's system, rather than to the management, which, however, appeared excellent in every department, doing great credit to Mr. Penn's intelligent and most obliging gardener.

There is, I find, an opinion that this system can only be useful in houses where fire heat is constantly used, and that for green-houses, or mere conservative structures, it will be nearly useless. My opinion is the reverse of this. In addition to its use in forcing-houses, where it may be deemed indispensable, I would adopt it in the green-house in preference to all other modes of heating. Green-house plants invariably do well while we can admit plenty of air; or while we can maintain a current to counteract the effects of damp. But there are sometimes months together that we cannot open a sash to effect this, without admitting air injuriously cold, or saturated with moisture; it is then we are doomed to see many of our tender favourites pine, droop, and die; and then that the advantage of an independent atmosphere, circulating at pleasure, and of any desired quality of heat and moisture, becomes of incalculable value. Admitting damp to be the greatest enemy that tender plants have to encounter during winter; that a current of air dispels that damp as effectually, and much more safely, than fire heat (the least excess of which is always hurtful, often fatal), the conclusion is, that plants in a damp state are really more benefited by the application of fire heat from the common it creates in the air, than from any trifling addition it may make to the temperature. Hence the great utility of Mr. Penn's apparatus, with which the same quantity of fuel will create a tenfold current, giving at all times the power of maintaining sufficient heat to keep plants in a state of health without the possibility of injuring them. Some persons suppose that plants will thrive better in a lower circulating medium, than they will do in a higher stagnated one; (that is, that they will do as well in a current of air heated to 60°, as they would where it is stagnated and heated to 70°;) then I reply that we know that plants of a more hardy nature will bear much more heat with the air in a state of circulation, than they will when it is stagnant. Therefore, with an atmosphere so truly under our control as that produced by Mr. Penn, we may reasonably expect an approximation in the habits of plants, that will render the division of structures, however desirable under any circumstances, less a matter of absolute necessity than it has hitherto been. It is, I think, not improbable that this may be the case to an extent that will render green-house grapes equal to the present forced fruit.

But it must appear premature, even to guess at the effects to be produced by a system the influence of which must be universal. Still we can hardly expect too much from any thing so strictly in accordance with the grand operations of nature. Mr. Penn's method is not, however, entirely dependent upon the ventilation. Supposing that to go for nothing, still there is much to recommend it left. His boiler gives unlimited command of heat at the least possible expense of fuel, and the whole apparatus is constructed with truly self-acting simplicity, which is an object of the last importance; and his manner of heating so many houses from one fire possesses advantages that must be obvious to all conversant with such matters, and must alone render it superior to all others. The saving of labour, consequently of expense, is great; while there is a certainty that one fire, upon which every thing depends, will be better attended to, and therefore perform the work better than if it were left to half a score fireplaces. Altogether, I have no hesitation in saying that, where the houses of an establishment are not too far apart to be connected, they will be better attended to than if they were separate. I do not mean to say that heat is often denied when absolutely necessary, but a little would often do good, when we are loth to heat a separate apparatus to produce it. Where the whole are connected, this can be done without, I may say, either time or trouble, and often, as chance may be, without a farthing of

expense. For example, suppose that any of the houses at work becomes overheated, turn the water for a time into any house that may be cold or damp, and you have a more reasonable and economical way of getting rid of the excessive temperature procured at so much expense, than by opening the sashes that it may escape into the external air.

I cannot conclude this paper without repeating your advice, and earnestly recommending all whom it may concern, to employ, in the erection of this apparatus, the inventor in preference to all others; they will thereby not only do an act of justice to Mr. Penn, but they will find him do the work better, and consequently cheaper, than any other mechanic.

Mr. Penn, be it understood, presses his invention upon no man. He courteously exhibits the effects it has produced to all who desire it, and leaves them to reject or adopt it at pleasure. Nor will he, I presume, trouble himself to notice the attacks that may be made upon it. While others are finding fault with his apparatus, he seems perfectly satisfied with pulling down theirs and substituting his own in their stead. A short time ago we had some of their apparatus, excellent in their kind, erected here; but now, thanks to the unsparring liberality of my respected employer, I have been allowed to extend the new system to every thing requiring it here, where it has been at work for some time, answering admirably. Should I have to report progress, independent of the opinion I have so unconditionally expressed, you may depend that it shall have fair play and no favour. The purpose to which the underground connecting pipes might be applied, in connexion with the still neglected scheme of portable houses, &c. (see my paper on the subject, in vol. xiii. p. 442.), will, should it prove sufficiently interesting, form the subject of another paper.

Folkstone, Sept. 24. 1840.

ART. III. *Notes on the Progress of Gardening in the United States during the Year 1840.* By A. J. DOWNING, Esq., Newburgh, near New York.

NOTHING has occurred so remarkable in the United States in the gardening way, as the late *Morus multicaulis* fever, as it is now called here, which has fully exploded and burnt out this past season, after a duration of about two or three years. The production of silk, which is at the present moment carried on to a very considerable extent, and which, no doubt, will in time be one of the most important branches of industry here, will undoubtedly be greatly benefited by the attention which the mulberry mania has attracted towards it. In the mean time, thousands have wasted their time and money in this idle speculation, and not a few have been ruined or much embarrassed by it. In the autumn of 1838, the demand for this species of mulberry was so great, that the trees were sold by the 100 and 1000 at prices varying from 1s. to 5l. per tree, according to the size and number of cuttings the plants would afford. During the winter of 1838-39, in New Jersey and Pennsylvania, the gardeners emptied their green-houses of plants, or built new ones to be occupied in the propagation of this far-famed plant; and, through the whole southern states, every one appeared to be occupied in the same manner; even the sashes were taken out of the dwelling-houses to cover hot-bed frames filled with the young cuttings. During the spring of 1839, the fever was at its height. Auction sales of the plants and cuttings were made daily in New York at enormous prices, large quantities were imported from France and the South of Europe; and not only were all the varieties of *Morus álba* sold for *M. multicaulis*, but even the branches of some of our native trees, as the *Tilia americana*, were sold in bundles for cuttings of the *M. multicaulis*. The ordinary price for buds (every bud will produce a plant) was two to five cents; and not only gardeners and agriculturists, but merchants, lawyers,

physicians, and divines, were found purchasing, and afterwards assiduously fostering, this newly discovered source of wealth. Although the summer of 1839 was an extremely unfavourable one, yet an accurate observer, who made the entire tour of the union from New Orleans to Boston, informed us that at the lowest calculation there could not be less than fifty millions of plants growing in the country. The natural result was, that in the autumn succeeding all came into the market as sellers, and none as buyers; the trees were first sold at a few cents each, and finally were not to be disposed of at any price whatever. During the present year, therefore, while immense numbers have served as brush for sticking peas, or have been entirely thrown away, a considerable number of individuals possessing the requisite means, as well as many farmers, have turned their attention to silk-growing with good success. In New England there are at least two towns that produce annually from 50 to 100,000 dollars' worth of silk; and, at the last fair of the American Institute in New York, specimens of tassels, fringes, and a great variety of silk fabrics of the first quality, were exhibited, entirely of domestic production and manufacture. Our sewing silk is admitted by the consumers of this article to be far stronger, and of equal fineness and lustre with the best Italian; and, from the more gradual and sure manner in which the silk business is making progress, we have no doubt that it will ultimately be of immense importance to the nation.

The Advance of Horticulture generally in the union is rapid, though, from its being diffused over such an immense territory, the results are neither so soon nor so easily appreciated as in a country covering a smaller superficial area, as England or France. Every year we find the number of what may be called handsome villas and suburban residences, with respectable, sometimes elegant, gardens and neat green-houses, increasing, especially in the middle and eastern Atlantic states. The recently increased facilities of importing rare plants by the medium of the steamers have given fresh stimulus to the exertions of amateurs and commercial gardeners in obtaining new species and improved varieties. Immense quantities of fruit trees, rose bushes, and ornamental shrubs, &c., are imported annually, and sold in New York; those from the French nurseries are, however, frequently of the most worthless description, though sold under high-sounding names. Although New York is the point of reception and delivery for a considerable portion of the union, it is far below Boston and Philadelphia in horticultural zeal or taste. This arises partly from the all-engrossing nature of the commercial pursuits of its inhabitants, and partly from the fact that its own direct suburbs are neither pleasant nor perfectly healthy for residence; hence, the more wealthy inhabitants form their country seats on the banks of the Hudson, the Connecticut, &c. The suburbs of Boston, on the contrary, are, perhaps, the most beautiful in the union, abounding with elegant and well cultivated residences of opulent citizens. The climate of Massachusetts being a little more inauspicious to the maturing of the finer fruits than that of the middle states, forcing is carried to greater perfection about Boston than in any other portion of the union; some of the finer places having from 500 ft. to 1200 ft. in length of green-houses and forcing-houses. Philadelphia is particularly remarkable for the taste for green-house exotics which has long existed there, as there are probably more plants grown there than in all the other towns of the union together. The public squares of this city are numerous and filled with choice and beautiful trees, and the windows and walls of the houses are more elegantly decorated with rare plants and climbers than is elsewhere to be seen. There are seven horticultural societies in the union, those of Boston and Philadelphia, of course, taking the lead in zeal and usefulness. Some idea of the interest manifested in these cities may be formed, when it is stated that the proceeds of the admission to the late exhibition of the latter society were nearly 4000 dollars.

No country in the world is more favourable to the growth of the finer fruits of temperate climates than the northern half of the United States. Although

the winters are moderately cold, yet, when the spring fairly commences (from the first of March to April), all fear of the chilling frosts so fatal in England is over, and the trees bloom and the fruit sets and swells with rapidity surprising to a European gardener. Walls are comparatively unknown, yet the poorest occupant of an acre of ground may have the finest peaches, cherries, plums, apricots, melons, &c., with the easiest possible out-of-door culture. Several attempts have been made by French and German emigrants to introduce the cultivation of the foreign grape for wine on a large scale. These have always failed, the wine grape of Europe being almost the only fruit of the other continent which does not arrive at an equal perfection here. But we have several native varieties which promise fully to supply their place for the vintage, if not for the table. Vineyards of these kinds are now in successful operation in various sections of the union, amounting in all to about 3000 acres. Mr. Longworth of Cincinnati, Ohio, a most intelligent and zealous patron of horticulture, has produced the finest wines; some of them indeed so nearly resembling the finest and most expensive imported varieties as not to be distinguished by the best judges. The yield of these American grapes is truly enormous, Mr. Longworth having produced at the rate of 3000 gallons per acre.

Commercial Gardens are constantly increasing as the wants of the country increase. Fruit trees are of course most in demand where so many new residences are being planted; but the taste for ornamental trees, shrubs, and herbaceous plants is every year becoming greater. Mr. Gordon has given a tolerably good description of the principal nurseries in a former page of your Magazine. The largest general nurseries at present are Wilcomb and King's at Flushing, and our own (A. J. Downing and Co.) at Newburgh, near New York. The latter covers about 24 acres; and trees and plants have been distributed in a single year over 23 states of the union, embracing a diameter of nearly 1000 miles.

Messrs. Winship's nursery at Brighton, near Boston, and those of Mr. Kenrick, are celebrated for their ornamental trees, as well as those of Landreth of Philadelphia. Colonel Carr's establishment, near the latter city, is especially remarkable for its fine native trees and tree seeds.* Besides these, there are nurseries at Albany, Burlington, New Jersey, Auburn, Rochester, and Buffalo, in the State of New York; several pretty large establishments at Baltimore, Washington, Charleston, &c.; besides 20 more new ones in progress at Pittsburgh, St. Louis, Cincinnati, and other places in the western states. The largest growers of green-house plants are Mr. Buist of Philadelphia, and Mr. Hogg of New York; the former, one of the most intelligent cultivators in the country, has about 13,000 square feet of glass. Mr. Thorburn of New York is the great dealer in seeds, and grows the dahlia to its highest perfection at his residence at Astoria near the latter city.

We are greatly in want of an experimental garden, like that of your Horticultural Society of London, to test the endless variety of fruits which are offered to the public by the various nurseries at home and abroad, and show their comparative excellence in this climate. None of our horticultural societies have yet been able to establish experimental gardens; and, indeed, there is no public experimental or botanic garden in America, belonging to any institution or corporate body, worthy of the name. Mr. Manning of Salem, Massachusetts, one of our best pomologists, has devoted himself to this branch of horticulture; and we have ourselves, fruited and tested during the past year, at this establishment above, 250 varieties of fruit, including nearly all the finest new varieties of Knight, Van Mons, &c.

* The nurseries of the Messrs. Prince, at Flushing, are in a rapid state of decay, and the green-house plants and other effects of the proprietor have lately been sold by auction.

A public garden for promenade has been commenced within a year in Boston, by a company of individuals, and a collection of plants purchased, green-house built, &c., which we hope may set an example worthy of frequent imitation in the other cities.

In relation to Floriculture, it is difficult to give an idea of the exact state of our gardens; for, while you will find 1000 gardens in which the rarest China and hardy roses, or the latest and most *recherché* dahlias, are blooming in the greatest beauty and perfection, in the neighbourhood of fine camellias, pæonias, hyacinths, tulips, &c., there is scarcely such a thing as a respectable collection of carnations, auriculas, pansies, or anemones in the whole country. This has arisen, however, in a great measure, from the fact that these latter florist's flowers have almost invariably perished in the long voyages of the packet ships, from being badly packed, &c.: and we hope soon to see them becoming every where common, since the rapid passages made by the steamers have enabled us to import them in excellent condition.

In the Literature of Gardening, but little has been produced here, as the current works of the English press, of a higher character, find their way across the Atlantic almost as soon as published. Buist's *American Flower-Garden Directory*, and Bridgeman's *Gardener's Assistant*, Kenrick's *Orchardist*, and Lindley's *Guide to the Orchard* (American edition), are the most popular works that have yet been published in this country. Hovey's *Magazine of Horticulture* is published monthly at Boston. Our agricultural periodicals, increasing daily in number and circulation, are working great good for the farming interest, and indirectly for that of gardening, by teaching some of the principles of the arts of culture, as well as practical results in all parts of the Union. The American Institute, which holds an annual fair or exhibition of the products of native industry in New York, second, in point of size or interest, to none in the world, has for two years past had a department, especially devoted to agriculture, where the choicest stock and pure blood cattle are shown and sold, and where ploughing matches to test the best implements are held. The present season they have also proposed a horticultural department, which, if carried out on an equally liberal scale, may be of great service in fostering a taste for horticulture.

Botanic Garden and Nurseries, Newburgh, near New York,

Sept. 30. 1840.

ART. IV. *Report on the State of Agriculture and Horticulture in Egypt.* Extracted from Dr. Bowring's Report on Egypt, presented to Parliament, and printed in 1840.

THE *Report* from which the following extracts are taken is one of the most interesting which can well be conceived. Egypt, which is generally considered to be a semi-barbarous country, in which it is dangerous to travel, and next to impossible for a European to live in comfort, is here shown to be making gigantic strides in civilisation, and all this through the efforts of one individual, the present pacha, or viceroy, Mahomet Ali. The few extracts for which we can afford room chiefly relate to agriculture and gardening; but as the *Report* itself, occupying 236 folio pages of small type, is, like other government *Reports*, sold for little more than the price of the paper (3s. 6d.), we recommend it to every reader whose heart is capable of expanding with delight at the prospects of human nature, in a part

of the world hitherto generally considered stagnant in respect to all that is good, and in the full plenitude of suffering from much that is evil. It is impossible to read this *Report* without being struck with admiration and astonishment at the comprehensive mind, impartiality, and delightfully liberal views of Dr. Bowring. The government which has employed such a man deserves immortal honour. A man, indeed, with so many qualifications for such a mission is rarely to be found; and we trust that he will be long blessed with health and strength to be similarly employed, and that a government may always be at the head of affairs in this country which has sense, liberality, and independence enough to engage him in labours which may be truly said to have for their object, not only the welfare of Great Britain, but the progress of civilisation throughout the world.

“*Agriculture.* — The causes of the general stagnation of agricultural and manufacturing improvement in the East will be found to be deeply seated and widely spread; for, though some evidences of progress may be here and there discovered, they must be considered as presenting a striking contrast to the almost universal result.

“There is in the Mahomedan religion itself a great want of encouragement to art, science, or industry. It does not give honour to labour. The book and the sword are the only two objects which it presents as worthy the ambition or the reverence of its votaries. The Imams, who sometimes preach with the Koran in one hand and a wooden scimitar in the other, are living emblems of the present state of the Mussulman world, — for the sword is powerless, and the book speaks in vain. Agriculture has no praise in the Koran, nor has manufacture nor commerce: it is the book of the desert, addressed to the inhabitants of the wilderness. The Nile is, indeed, an object of religious veneration among the Egyptians, as wells and water-springs are to the Arabs; but the attachment of the fellahs to their fields and to their plantations, which distinguishes them from the great body of the Mahomedans, has in it much of Paganism, which, indeed, held the plough in honour. The Koran was addressed to warriors — to the fighting men of the waste. The Mahomedan cultivator seems to accept and resign himself to a recognised condition of humiliation and inferiority — for him there is little comfort in the holy book. If an Egyptian artisan be asked to undertake any labour analogous to the cultivation of the soil; as, for example, to assist in the care of a garden, in the enclosure of a field, or any similar work, he will indignantly answer, “Am I a fellah?” Hence the pursuits of agriculture imply degradation, and the peasantry represent not the pride, but the poverty — not men aspiring to wealth and influence, but those contented with a meek and unresisting servility.”

After speaking of the measurement of land and the rights of property, the principal agricultural produce of the country is stated to be trefoil, grain, beans, barley, peas, and other seeds, which are threshed at “a kele per day,” and the threshed corn watched by a man at a kele per night, “independently of what he steals. The distribution of lands, the soil, “the powers of which are incalculable,” the encroachments of the desert, the hot winds, and the locusts, are next reported on.

“*Encroachments of the Desert.* — But a perpetual struggle is carried on between the desert and cultivation. In many parts of the Delta the desert has

invaded and mastered the soil. In the neighbourhood of Abouzabel, in the district of Essiout, and some other parts of Egypt, the desert has been vanquished by cultivation. In fact, were there hands to plough, and water to irrigate, it is not easy to calculate what an immense tract of territory might be rescued from waste. Still, to counterbalance, as it were, the productive powers of the soil, other difficulties peculiar to eastern regions present themselves in Egypt.

“*The Khamsine, or hot Winds.* — The hot winds of the desert often destroy the hopes of the husbandman; their intensity and duration become objects to him of the greatest anxiety, for there are seasons in which the khamsine (which takes its name from its ordinary duration of fifty days) dries up whole districts, even after irrigation. Added to this, the prospect of large and productive harvests is sometimes suddenly cut off by the visitations of *Locusts*, which appear in clouds of myriads, destroying everything before them. I have seen dense masses of this all-destroying plague, followed by multitudes of hawks and other birds, filling the atmosphere for a vast space, and then descending on the fields of corn, which they completely devastate, and then wing their way to another spot, to be devastated in its turn.”

The Inundations of the Nile form a subject which surely cannot be uninteresting to any gardener who has read his Bible.

“All countries,” Dr. Bowring observes, “are subjected more or less to the action of the seasons on their agricultural productions, which are increased or diminished according to the circumstances more or less favourable to seed-time, growth, and harvest. But in Egypt one necessity absorbs all others; the sunshine to ripen, the fair weather for gathering the fruits of the earth, may always be reckoned on, but, unless the inundations of the Nile irrigate the lands, in vain through immense districts is the seed sown, in vain the husbandman goes forth to harvest. The inundations are very various in their character and consequences: when favourable to the upper regions, they are excessive in the lower; and when they suit the lower districts, they sometimes leave the higher country almost dry.”

We omit great part of the subject to notice the curious and melancholy fact contained in the following sentence: —

“It may be doubted if the farmed land is less than it was a generation ago; in some districts it is undoubtedly greater; but the hands which cultivate are diminished in number, and their efficiency has been considerably interfered with by the habit of mutilation to which they have recourse as a means of escaping the military life, to which the Egyptian Arabs have a singular repugnance, not only from the dangers they are exposed to, but from that passionate love of the valley of Egypt which is the universal characteristic of the race.”

Cultivation by Surface Irrigation is practised in all warm countries, even in the South of France; and perhaps the time will arrive when the importance of watering, as an element of high artificial culture, will be better understood in England than it is at present. How we can think it reasonable to supply every other element in our fields and gardens, and yet withhold that which is the life and soul of growth in plants, is not easily to be accounted for; but this is not the time to enter on the subject. Dr. Bowring informs us that there are in Lower Egypt 50,000 water-wheels for cultivation by irrigation, each

worked by three oxen and two men. They work, on an average, 180 days in the year. There is, besides, another kind of machine for raising water, called a "shadoof," of which there are a great many worked by men without oxen. Dr. Bowring calculates that these water-wheels may be in a great measure dispensed with by throwing a dam across the Nile at a short distance from the fork of the Delta; — a magnificent idea, the sublimity of which can only be fully felt by those who have seen a wide river passing through a perfectly flat country, such as Holland. In a subsequent part of the *Report*, it is stated that the use of steam-engines for throwing up water may probably render such a dam unnecessary.

Canals and Wells have been at all times in use for agricultural purposes in the region above the valley of the Nile, and many of these have been constructed, excavated, or repaired, by the government of Mahomet Ali.

The government, it seems, is obliged to force the inhabitants to cultivate the ground according to approved rules.

"The excuse alleged for forcing a particular cultivation in Egypt is, that the lazy habits of the fellahs would induce them to abandon cultivation altogether, or, at all events, only to produce the articles necessary for their own consumption, and such as required the smallest application of labour, were not the despotic stimulant applied. On one occasion, when I suggested to Mahomet Ali that a greater latitude left to the cultivator would lead to an increased production, he replied, 'No! my peasantry are suffering from the disease of ignorance to their true interest, and I must act the part of the doctor. I must be severe when anything goes wrong.'

"The indolence of the fellahs may be, to a certain extent, a justification of that direction which the government gives to cultivation, by requiring the production of certain articles in particular localities, not allowing to the peasant or proprietor to decide as to what produce would be most profitable to him.

"The authorities aver that, where a greater liberty of action has been given to the cultivator, his produce has been less, and that the ordinary motive of the love of gain is not so strong as the unwillingness to labour. As far, however, as I was enabled to judge, the desire to accumulate and to retain wealth is as active and as influential among the fellah race as in any other class of human beings; and, were the rights of property better defined and respected, and a system of regularity introduced into the fiscal machinery of Egypt, the peasantry might be very safely trusted to take care of their own interests."

This state of things in Egypt is not very different from what was the case in the very best cultivated districts in Scotland about the beginning of the last century; in proof of which see Cleg-horn's *History of Agriculture* in Black's edition of the *Encyclopædia Britannica*, now in course of publication.

Passing over several pages, which it would be interesting to quote if this Magazine were as much devoted to agriculture as it is to gardening; and leaving the culture of dourah grass (*Hólcus Sórghum* L.), rice, tobacco which is grown to a considerable extent in Middle Egypt, cotton the culture of which

is given in detail, wheat, pulse, the mulberry for silk, the sugar-cane for sugar, and the poppy and the olive for oil; we come to the culture of the rose for rose-water, a subject which, we trust, will interest at least one portion of our readers.

“*Fayoum is the Land of Rose Trees.* — In May the soil is twice turned up, divided into squares, and slips are then planted in holes at a distance of $2\frac{1}{2}$ ft. The slips are covered with earth, which is kept constantly humid, till the trees appear above ground, when the irrigation is lessened and the trees reach their natural height of about $2\frac{1}{2}$ ft. At the end of December the shoots are cut at the surface of the ground, irrigation being recommenced for thirty to forty days, being the time necessary for the budding and blowing of the flower. The roses are gathered every morning before sunrise, while covered with dew; they are placed in an alembic ere they dry or heat, and the distillation lasts six hours. The water is white when drawn from the alembic; that offered for sale is generally yellowed by a mixture of water from roses which have been infused. A feddan gives from 6 to 7 quintals of roses. In 1832, 800 quintals were collected. By a reduction of 50 per cent from distillation, these 800 quintals give 400, which produced 40,000 rottoli of rose-water. A feddan planted with rose trees costs 60 piastres for culture and taxes, and gives 3 quintals, which give 300 rottoli, which, at 3 piastres, produce 900 piastres net. But no person is allowed to distil roses for his own account, and those who cultivate them are obliged to sell them to the government.

“The manufacture of rose-water, for which the Fayoum was so distinguished, is reduced to very small results. There are a few acres of rose garden in the neighbourhood of the capital (Medineh el Fayoum), but their produce is trifling. The monopoly of rose leaves, for which so small a sum is allowed to the cultivators, has rendered the cultivation by no means worth the attention of the peasantry or landholders. It is seldom that any cultivator has more than a single feddan dedicated to the production of rose trees. The price paid for rose leaves is 25 piastres = 5s. per cantar. Of fine rose-water a small quantity is made for the use of the government; but that produced for sale is of little value and of indifferent character. There are three qualities of rose-water produced; they sell for 3 piastres ($7\frac{1}{2}d.$), 5 piastres ($1s. \frac{1}{2}d.$), and 7 piastres ($1s. 5\frac{1}{2}d.$) per bottle.

“Otto of roses is not manufactured in the Fayoum, though the free cultivation of rose trees would, I am assured, enable its inhabitants to compete with any part of the East in its production. The consequence of the monopoly is the gradual diminution of rose trees throughout the district, every person being interested in producing as few as possible.

“*Dates.* — One of the most productive and most extensively cultivated objects of the vegetable kingdom is the date tree. It is spread over all Egypt, is a source of considerable revenue to the government (1 piastre per tree being generally levied), and administers, both by its fruit, trunk, branches, leaves, and fibres, to the comforts of the natives, far more than any other product of the soil. As a source of landed revenue it is highly lucrative. One proprietor told me that he had planted 5000 date trees, which, after eight years, had produced yearly fruit of the average value of from 40 to 80 piastres (8s. to 16s. sterling) per tree. Revenue is collected on about two millions of date trees.

“*Madder.* — Madder is produced in Middle Egypt to some extent for the consumption of the country, principally for dyeing the tarbouche, or skull-caps, which are universally worn. Madder cultivation was introduced in 1825. In 1833 there were 300 feddans in Upper Egypt, and 500 in the Delta and the Kelyouh, devoted to madder roots.

“*Wines.* — Egypt was never celebrated for its wines. Herodotus says it produced no wines in his time. A few attempts have been made, principally by Ibrahim Pacha, to introduce the cultivation of the vine; and some

tolerably good wine has been made. The white wine resembles Marsala, though it is not equal to it in quality; the red is somewhat similar to the common wine of Spain.

“*Trees.* — 1. The indigenous trees of Egypt are few. The Acacia (Iebbek) has a fine foliage in the time of the inundation. The heart of the trunk, which is black, is employed in wheel-making and sakias: the white part of the trunk easily decays.

“2. The sycomore (gimmis) [*Ficus Sycómorus Lin.*] is knotty and not easily split; it is used much in the construction of sakias. Its fruits grow from the trunk, but do not ripen unless cut.

“3. The Acacia nilotica (saat) is used for hedges and enclosures; it is also employed for boat-building on the Nile, for sakias, and for charcoal. In Upper Egypt gum is extracted from this tree. Boats are constructed in Senaar of the saat, which comes down the Nile for sale. Its fruit, called karat, is used for tanning, and it completely impregnates the leather in forty days; so tanned, the leather resists heat admirably, but not humidity.

“4. The etl is a tree of light wood, which flourishes with so small a quantity of water as to grow on the skirts of the desert. Its appearance resembles the cypress.

“5. The nebk is a tree bearing fruit resembling olives, whose wood is employed for various purposes.

“6. The doum (*Hyphæne coriacea*) is a dichotomous palm; the wood is used for the making of sakias. It is of a fibrous texture, not easily split.

“7. The date palm (*Phœnix dactylifera Lin.*) is the most common and most useful of Egyptian trees. It is easily propagated by the off-shoots from the roots: of its leaves, brooms and brushes are made; of the *lif*, by which the branches are bound together, all sorts of cordage; the trunk is employed for house building and many other purposes; and the fruit, of universal consumption.

“Olive trees are now introduced in large quantities, and produce fruit in three years.

“Orange trees are very numerous in the province of Galiub, and lemon trees are common. There are many plum trees, and some apple and peach trees; large quantities of figs and cacti.

“There are few medicinal trees; among which, the khiar shember's fruit is used for purging.

“The fibres which bind together the branches of the date trees are an article of great consumption in that country, being used for purposes of cordage: in the Fayoum, these fibres (*lif*) are of a peculiarly fine quality.

“*Onions.* — There is a very large production of onions in Egypt, far larger than that of potatoes, which, indeed, do not succeed well in the rich alluvial soil. The ordinary price of onions is from 4 to 6 piastres per cantar, or about 1s. the cwt.; but the price was trebled in 1837, from the general deficiency of food. So large is the consumption, from the employment of the onion in such a variety of dishes, and for such a variety of purposes, that a person of the opulent ranks assured me he consumed in his family, whose annual expenditure was about 300*l.* sterling per annum, nearly two tons of onions.”

The expense of living for an agricultural labourer in Egypt is about half the price of labour; and it is a curious fact, that the proportion between the expense of living and wages for the lowest description of labour was the same in England about the time of Elizabeth, and, in fact, has been nearly the same in all countries where the labourer had few or no enjoyments of an intellectual nature; in short, previously to the time when labourers could read. In the present century, in England, the

proportion begins to differ, but still the expenses of workmen of every description are constantly treading on the heels of their incomes, and, from the innate desire to enjoy our condition, will probably always do so. A fellah, or agricultural labourer, in Egypt, receives about 1*d.* per day, and if he is prudent he can live on $\frac{1}{2}$ *d.* per day. We now come to the important subject of

“*Horticulture.*— Much has been done in Egypt for horticultural improvement; many of the gardens are beautiful in appearance, and rich in their possessions; the most striking are in the care of Europeans; that of Ibrahim Pacha, in the island of Rhoda, is one of the most attractive. It is under the superintendence of Mr. Traill, A.L.S., C.M.Z.S., &c., and is kept in order by about 120 workpeople, whose average earnings are a piastre (2 $\frac{1}{2}$ *d.*) per day; the extent of this garden is about 40 acres. In this garden many very interesting and important experiments have been made, which are likely to have a happy influence on the future productions of the country. I found the teak tree in a most flourishing state. In a period of seven years it had reached the height of 25 ft., and was most luxuriant in appearance. Mr. Traill had been producing the teak from seeds, and there were about 300 teak trees in the garden. As forest trees are almost unknown in Egypt, the timber consumed for ship-building, for domestic and general purposes, being principally imported from Syria, the introduction of the teak is of the highest interest and importance to the country. The bamboo, the yam, the caoutchouc, the ginger, and the arrow-root had also completely succeeded, and, in the opinion of Mr. Traill, may be cultivated without difficulty to any extent. The custard apple also has been introduced and prospers.

“The experiments that have been made in the cultivation of the coffee and tea plants have not been fortunate, and it is to be feared that the soil of Egypt is not friendly to their production. But that the introduction of many important agricultural articles, which have hitherto not been attended to, would add greatly to the resources of Egypt, there can be no doubt. The inertness of the fellahs, the unwillingness to try any new produce, however much the cultivation may promise, have been the cause of the scanty number of articles which the Egyptian soil, so rich and exciting, has hitherto nurtured. Nothing but the stubborn purpose of the Pacha would have led to the growth of such vast supplies of cotton, to the cultivation of opium and indigo, and other objects of European consumption. The peasant is always desirous of producing what he and his neighbours consume, in preference to articles for export; and it is to be feared, the coercion which is exercised towards the fellah, in order to compel the growth of the principal articles of demand for foreign markets, finds some justification in the unwillingness of the cultivators to attend to them without the arbitrary interference of the authorities.

“The successful attempts which have been made in the gardens of Egypt, may ultimately produce in its fields results of a more extensive character. Horticulture is in that country scarcely distinguishable from agriculture, and will, probably, by the attractions of greater profits, encourage adventure. Ibrahim Pacha has, indeed, been very willing gratuitously to distribute seeds and plants and trees from his own garden; but the cases are rare in which any attention has been paid to them by the receivers.

“To the Pacha the horticulture of Egypt owes much; not only are his own extensive gardens watched over by intelligent and skilful botanists, but he has sent travelling gardeners to the East Indies and other parts, in order to collect specimens of such vegetable productions as are likely to suit the Egyptian soil. Nor is there any unwillingness on his part to incur any expenses for the furtherance of botanical science, and for making it instrumental to the general agricultural interests of the country. [Dr. Bowring informs us,

and, indeed, the fact had been previously stated to us by Mr. Traill, when in England in 1838, that the Pacha had sent Mr. McCulloch, one of his head gardeners, to British India, and that he had brought to Egypt forty cases of plants, seeds, and roots.]

“ I have been favoured by Mr. Traill with the following interesting statement as to the success of his horticultural experiments : —

“ ‘ Rhoda, 9th February, 1838.

“ ‘ Dear Sir,

“ ‘ While sending you the enclosed list of some of the more valuable plants introduced into the gardens of His Highness Ibrahim Pacha, since their formation in 1830, allow me to state that we possess, besides, many highly interesting species, as the mango, cocoa nut, black pepper, cinnamon, tea, &c. ; but, being a very recent acquisition and now under experiment, I have thought it better not to add them, until enabled by time to form an opinion as to the probability of their naturalisation.

“ ‘ The list sent you contains only such subjects as have either been decidedly acclimated in Egypt, or from which satisfactory results have been obtained.

“ ‘ I remain, dear Sir,

“ ‘ Yours most faithfully,

“ ‘ Dr. Bowring.

“ ‘ (Signed)

JAMES TRAILL.

“ ‘ List of some of the most useful Plants introduced into Egypt within the last eight Years.

English Name.	Botanical Name.	Date of Introduction.	Observations, &c.
Star apple - -	Chrysophyllum Cainito	1830	Acclimated — but has not yet produced fruit.
Guava - - -	Psidium pomiferum -	—	Introduced by Mr. Briggs many years ago, but, having been neglected, no result was obtained till taken up by me in 1831 — is now perfectly naturalised — producing fruit abundantly.
Coffee - - -	Coffea arabica -	1830	Seed sown in 1830 — several plants of which produced fruit last year, but, from the extraordinary care required in preserving the plants, ultimate naturalisation very doubtful.
Teak - - -	Tectona grandis - -	1831	Of six plants raised from Indian seeds, one has now attained the height of 29 ft. 4 in., being an average growth of upwards of 4 ft. annually ; girth at one foot from the surface of the ground 2 ft. 4½ in. Another plant of smaller dimensions produced seed last year.
Papaw tree - -	Carica Papaua - - -	1834	Acclimated — fruited.
Arnotta - - -	Bixa Orellana - - -	—	Acclimated — grows freely — but hitherto no produce obtained.
Allspice - - -	Myrtus Pimenta - - }	—	Live, but do not prosper.
Sago Palm - -	Cycas revoluta - - }	—	Acclimated — not fruited.
Custard apple -	Annona Cherimoya - -	—	Ditto — vegetates freely.
India rubber tree	Ficus elastica - - -	—	Ditto, ditto.
Turmeric - - -	Curcuma longa - - -	—	Ditto, ditto.
Arrow root - -	Maranta arundinacea	—	Ditto, ditto.
Ginger - - -	Zingiber officinalis	—	Acclimated — tree 14 ft. high — grows vigorously.
Cedar wood - -	Cedrela odorata - - -	—	Acclimated.
Fustic - - -	Morus tinctoria - - -	—	Acclimated — tree 15 ft. high.
Benzoin - - -	Terminalia angustifera	—	Acclimated — tree 14 ft. high.
Cajeput - - -	Melaleuca Cajeputi. -	—	From five tubers planted last year, an average produce of fifteen-fold was obtained — successful cultivation indubitable.
Yam - - -	Dioscorea aculeata -	1837	A small plant, having been placed close by a canal of irrigation last year, threw up three vigorous shoots upwards of 10 ft. long, which, having stood the winter uninjured, puts the naturalisation of this valuable plant beyond question.
Bamboo cane -	Bambusa arundinacea	—	

“ There is everywhere resistance, a resistance not peculiar to Egypt, to the introduction of improved agrarian instruments, and, of course, improved husbandry makes little progress ; the same old plough, the same rude tools which were employed a hundred generations ago, are still in use ; and I did not find that even the Egyptians and Turks who had travelled in Europe had brought back with them any disposition to attempt a superior method of cultivation. In the model farms established by the Government the best instruments are used ; but the influence of these establishments has hitherto been small.”

From the remainder of the *Report* we shall merely glean a few facts or observations.

The creation and destruction of earthenware vessels goes on to a vast extent ; and the wheel by which the clay is turned seems to have undergone no change from the patriarchal times. The stones of some of the finest temples in Egypt have long been employed in the manufacture of lime ; a barbarous practice, which we are not to be so much surprised at when we consider what frequently takes place in this country with the finest Gothic ruins, which are frequently made quarries for modern buildings, or even fence walls. The Pacha has put a stop to this practice in Egypt. Salt is obtained by the peasants by soaking the bodies of mummies in water, and afterwards evaporating it. Even the sand and stones on which mummies have lain are found impregnated with salt, and they are also steeped in water. Here are wants to be supplied which might form the germs of three sure and lucrative manufactures : improved pottery ; lime-burning from native limestone, which is abundant ; and salt-making from sea water. In the government administration there is a minister for public instruction, who is also director of the public works, &c. One of the duties of this minister is, to see that schools and instructors are provided for all the youth of both sexes in every part of the country, and we cannot help wishing that he would introduce the teaching of English into all these schools, as one step towards the universality of that language. This minister's duty is also to inspect all plans for buildings, public or private, and to protect the monuments which already exist. Dr. Bowring, at the request of the viceroy, drew up a plan for a commission to be charged with the preservation of public monuments, researches for new discoveries, and the establishment of a museum in which all the more valuable smaller objects should be collected. This excellent idea we trust will be carried into execution. In all primitive countries there is little change in the fashions of dress, but, since the Pacha began his improvements, the beauty, variety, and economy of European cottons and silks, are gradually working a revolution in the dress of both sexes, which will end in firmly binding the East to the West by the links of commerce. There are regular steamers from various parts of Europe to Alexandria,

but the ordinary passage is from Marseilles, which occupies fourteen or fifteen days, including stoppages, and costs for each passenger 2*l*. Letters between London and Alexandria arrive in from seventeen to nineteen days, and cost about 2*s*. each. We mention these prices, because we have no doubt some young gardener will be disposed to offer his services to Mr. Traill, whom from our personal knowledge, we can state to be a most excellent man much attached to Egypt. The accounts of the slave trade and slave hunts are horrible. The natives are burned out of their hiding places, like wasps or foxes; or caught by snares or traps, like game or vermin. For the sake of impressing on the reader's mind the incalculable blessings of civilisation, we make the following quotation, though we admit that it is somewhat foreign from the subject of gardening.

“As the pay of the troops was often in arrear, they generally showed no little activity in capturing the negroes, on whose sale they were to depend for the settlement of their claims; and there is sufficient evidence that horrible atrocities are frequently committed in the capture of slaves. In some cases, where the blacks had retreated to caves and caverns, fires of straw and brushwood have been kindled at the entrance in order to force them out by fear of suffocation. Resistance leads to frays in which much blood is shed; but, generally, the poor slaves are seized by men in ambuscade, from their mothers when in the fields, from small parties of blacks who are surprised or waylaid by the soldiery, or by individual acts of kidnapping. Wars are entered upon for the purpose of making prisoners to be sold as slaves; the quarrels of petty communities are engaged in for the sake of handing over the weaker party to the jellab or slave dealer. Sometimes the strong sell the weak, even of the same tribe; in a word, there is no crime which is not committed on the spots where the slave trade has its birth.” (*Report, &c.*, p. 83.)

So brutal is the usage of the negroes after they are captured, that it is estimated that 30 per cent perish in the first ten days after seizure. The facts related by Dr. Bowring on this head are fearful. In estimating the positive suffering, however, we must make allowance for the different state of feeling among a people so degraded; even the memory of these people is so little cultivated, that it only reaches back a few years, and their future prospects of life are so limited, that they have scarcely any thoughts which reach beyond a few days or weeks. Nevertheless they are “almost invariably fierce religious fanatics.” The Pacha seems favourable to the abolition of the slave trade, but he does not appear to have taken any active measures against it.

“*Hatching of Eggs.*—From fifteen to twenty millions of chickens are annually hatched in Egypt by artificial heat. One chicken is given for two eggs.”

“*Misdirection of Labour.*—The misdirection and waste of labour in the Levant are very great; thought is seldom associated with the ordinary occupations of life. If rubbish is to be removed, for example, a large portion will be spilt from the baskets or carriages into which it is thrown; if timber-work is to be repaired, little attention is paid to the fitting of the various parts; seldom is a room made air-tight, either from the door or windows; seldom is a staircase found in which the steps are of equal heights.”

“ *Associated Labour.* — Sometimes labour is divided among small bodies of labourers ; and I observed in Upper Egypt an ingenious device for the equal distribution of their toil. Where a certain number of fellahs had to divide the work in the fields with an equal number engaged in raising water by the shadoof, they had made a primitive sort of sundial by sticking a piece of wood into the earth, and marking the hours at appropriate distances by bits of chalk. When the shadow reached the given spot, the field labourers took the part of the irrigators, and so interchanged their employment. I inquired how they settled this when there was no sunshine, and they said they made a small hole in an earthen vessel, which they filled with water, and when it was run out they shifted their work, filling the vessel again to measure the labour of the new comers.”

Commission of Ornament in Alexandria. — A correspondent in our volume for 1835 (p. 280.) has suggested the idea of a society for promoting the improvement of the public taste in architectural and rural scenery ; and we have shown in the same volume (p. 283.) that such a society exists at Munich, where more attention is paid to public convenience and ornament than in any other country in Europe, not even excepting France. We were not, however, prepared to meet with an establishment of this kind in Egypt.

“ *Commission of Ornament in Alexandria.* — Among the establishments which show the gradual progress of improvement in Egypt, I cannot avoid mentioning the Commission of Ornament in Alexandria, instituted for promoting the cleanliness, healthfulness, and beauty of that important place. I had an opportunity of examining the proceedings of the board since its establishment. It has done much for the well-being of Alexandria, by providing for a freer circulation in the streets, for the ventilation of houses, and generally by the supervision of all buildings erected or proposed. No new building can be constructed without the approval of the board, which is authorised to order the removal of all nuisances affecting the public health. The British consul-general is the permanent president of the commission. It consists of some of the Egyptian authorities, with a greater number of Europeans. There is a civil engineer who is especially attached to it, and the board has been instrumental in introducing many improvements and getting rid of many nuisances, thus adding much to the salubrity of the place. It has received on all occasions the cordial support of the government. The viceroy himself, and all the officers of the government, submit to its ordinances.”

“ Among the useful suggestions which I understand have emanated from this commission, one has been the removal of all the cemeteries to without the walls of Alexandria, The Mussulmans have now their burial ground ; and each Christian sect, Copts and Greeks, Armenians and Catholics, and Protestants, as well as Jews, have each a separate resting-place for their dead, at some distance from the town.”

Perhaps the most interesting part of the whole *Report* is that which relates to education. It occupies above twenty pages, and is full of the most gratifying details. There are primary schools to be spread in all the provinces, according to the population ; the system of instruction is to be the same in all, and all children are to be compelled to undergo it. But for this, and various other interesting subjects of general improvement, we must refer to the *Report* itself.

ART. V. *Notes on Provincial Nurseries.* By J. P. W.

NO. 1. THE MILFORD NURSERY, NEAR GODALMING.

PERHAPS you will allow me to lay before you and your numerous readers a few remarks I lately made in visiting some of the provincial nurseries; and as that at Milford, near Godalming, belonging to Mr. William Young, was the first which I visited, I shall accordingly begin with it.

The Milford Nursery occupies a beautiful situation about half way between London and Portsmouth, with the Portsmouth Road running along its southern boundary. The nursery abounds in every description of tree generally used in extensive planting, with an immense number of evergreens, such as laurels, yews, cedars, hollies, box, &c. In passing along the road, the general effect of the nursery is very striking, from the appearance of the extensive pits and green-houses which meet the eye, backed by numerous thriving young trees, assuming at a distance the character of an evergreen plantation. On entering the grounds I was not a little pleased with a fine specimen of *Juniperus thurifera* Lin., forming a beautiful spreading evergreen tree feathered to the ground, and hence an appropriate ornament for the lawn, or to stand out singly from a group where a low-growing tree is required. A little further on I observed several fine specimens of *J. phœnicea* Lin., *Cuprèssus sempervirens stricta* Arb. Brit., and *Taxus baccata fastigiata* Arb. Brit. In a turf pit not far from these large specimens, I saw a fine specimen plant of *Cuprèssus torulosa* Lamb.; and, in pots, above 50 strong young plants of this species for sale. Also in pots, several fine specimens of that beautiful and, since the winter of 1837-8, scarce tree, *C. lusitânica* Tourn. In my opinion this evergreen ought to be in every collection of *Coniferae* in the country; as also *Juniperus excelsa* W., which forms one of the finest trees of all the section *Cuprèssinæ*, attaining a height of 60 ft. with a slightly pendent habit. I have no doubt that, from its great elegance, this tree will in a few years become plentiful in our nurseries, as, from its extensive geographical distribution, seeds might be either procured from the New or Old World; from the latter, no doubt, through the Calcutta Garden. At present Mr. Young's stock of it appears limited, as I only observed a few small plants in pots. In *Abiétinæ* Mr. Young seems very rich. I saw fine specimens of *Pinus Banksiana* Lamb., *P. Sabiniæna* Doug., *P. Coulteri* D. Don, *P. longifolia* Roxb., *P. canariensis* Smith, *P. excelsa* Wall., *P. Lambertiana* Doug., *P. monticola* Doug.; with many of the common sorts in large quantities, such as *P. pumilio* Hænke, *P. Laricio* Poir., *P. austriaca* Höss, *P. Pallasiana* Lamb., &c. &c. Among the rarer *Abies* I observed *A. Smithiana* Wall., *A. Douglàsii* Lindl., *A. Menziesii* Doug., *A. cephalonica* Arb. Brit. [now *Picea cephalonica*]; and in *Picea* nearly all the species. There is also a fair proportion of all the genera belonging to *Coniferae*.

As this is the season of the year when all deciduous vegetation begins to fall "into the sere and yellow leaf," I was not a little pleased in observing the various tints of autumn, especially in the genus *Quercus* (which is here rather numerous, counting above thirty species, exclusive of varieties). *Q. tinctoria* Willd. was in all its beauty, as was also *Q. rubra* L., with most of the same section. There are some fine full-grown specimens of American *Quercus* and acers in the arboretum of P. B. Webb, Esq., Milford House, which adjoins the nursery, and which are now clothed in yellow, orange, purple, red, and scarlet.

In a compartment near one of the green-houses, I observed a numerous collection of *Cratægus* Lindl., containing about 50 species and varieties, all named according to the *Arboretum Britannicum*: and in a row not far from the above was a fine assemblage of pendulous trees, consisting of weeping ash, weeping willow, weeping beech, weeping elm, weeping poplar, weeping

laburnum, weeping birch, and that most beautiful of all weeping trees, the *Sophora japonica pendula* *Arb. Brit.* When grafted high, this tree forms one of the most delightful living vegetable umbrellas imaginable, especially when trained *en parasol*.

But leaving with regret the plants of the open air, where I pass over many varieties unmentioned, I will give a hasty glance at the inmates of the greenhouse. On entering it, I was much pleased with a splendid collection of heaths, second to none in England for luxuriance of growth, and the size of the specimens. Many were in full flower, and many more in an advanced state. At the end of the house I observed a splendid specimen of *Banksia speciosa* *B. Mag.* in full flower. This alone was a treat worth going to see. There was also a very extraordinary specimen of *Rhipidodendron plicatilis* *Hort. Brit.*, which is of a great age, and is sure to arrest the attention of every visiter. The camellias looked well, as also did a quantity of *Rhododendron arboreum* *Smith.* In one of the pits, the pitcher plant grows luxuriantly; for although this plant has generally been kept in a stove, yet it will stand in a house where the thermometer falls below freezing, as I am told the individual here did last winter; for though it had the ice on its leaves as thick as a sixpence, yet it did not suffer from it in the least.

In a Dutch pit there were above 20 species of *Kennedyia* and *Zichya*, being nearly all the sorts yet introduced into this country. There are two or three species quite new that have not yet flowered; also several other good things, amongst which I may notice *Pronaya elegans*, a climbing plant nearly allied to *Sollya*; also *Convolvulus scoparius*, one of the rarest of the genus, and perhaps not yet to be found in any other collection in England. I could go on to enumerate many other good and rare plants which I saw here, but I will only notice the following hardy trees and shrubs, which I believe are not very common in the London nurseries, and which it may be useful to those planting arboretums to know may be had from Mr. Young: *Aràlia japonica*, *Atraphaxis spinosa*, *Nitraria Schóberi*, *Kadsura japonica*, and *Paulownia imperialis*.

If I do not meet with a situation soon, it is my intention to visit some of the principal nurseries in different parts of the country, and then perhaps to go to Scotland, and you shall hear from me accordingly.

Bristol, September, 1840.

ART. VI. *How to get rid of Insects that have attacked the Cacti.* By
M. EMIL SELLO.

(Translated from the *Garten Zeitung*, by J. L.)

It is well known to every gardener and cultivator of the Cacti, that the expulsion of the insects so injurious and destructive to this tribe of plants is particularly difficult to effect; and it is also a fact, that the scale which is found between the spines on the elevated parts and small protuberances of many species cannot be got rid of, without destroying the specimen. Permit me, then, to make known to you a more suitable method, for the expulsion of such injurious insects, than I ever saw in practice during my journey.

In the establishment of M. Makoy in Liège, a very simple and, therefore, easy method has been practised for a long time most successfully, without the specimens on which it was employed sustaining the most trifling injury. Such an operation is generally performed elsewhere by means of a small brush, or other small kind of instrument, which occupies several hours, and is frequently attended by the injury of the exterior of the plant; but here it is effected in the course of a few minutes, without the plant sustaining any injury whatever. Many species of the *Mammillaria*,

such as *M. radians*, &c., cannot be cleaned with a small brush, as this brush cannot penetrate between the numerous and thickly set spines, which are the favourite abodes of the insects. Powdered sulphur was also used to destroy the molesting intruders; but this had not only a very disagreeable appearance for a long time, but its application was attended with injurious consequences to the plants. The simple method, therefore, practised in the above establishment cannot be sufficiently recommended, and I now subjoin the directions for its application. On a fine sunny day take a cactus plant which is attacked by an insect, and cover the earth in the pot with a cloth, so as to prevent it falling out during the operation; then make a boy hold it over a tub or cask with both hands, and take a good-sized syringe, that has a great many small holes at the end, and fill it with clean water, but not very cold, because, if otherwise, the outer cellular tissue might get a chill; then holding the syringe at some distance, let the water play with more or less force on the upper part of the plant, and by its gushing and penetrating power, the placidly reposing insects are soon roused, and, with all the impurities, are washed away without the most trifling injury to the plant. This method, however, is not sufficient for the destruction of the scale, because it sticks so firmly on the exterior of the plant, that the force of the stream of water cannot remove it; but in order to effect this, it is necessary that the plant should be soaked in tobacco juice for several hours before it is syringed; and it is understood, that the tobacco juice must not penetrate into the earth in which the plant is grown. The scale by this means is killed, but not removed from the plant, but which is readily effected by the application of the syringe, as above described; and it is particularly necessary, that a dry sunny day should be selected for the operation, so as to facilitate the drying of the attacked and syringed plant. All kinds of *Echinocácti*, *Melocácti*, and *Mammillariæ* are the easiest purified in this manner; also, the *Cereus* species, when they are not too large; but large specimens of *Cereus* and *Opuntia*, *Epiphyllum* and *Pereskia* require, as may easily be understood, the greatest care and attention. As I have practised this method of expelling injurious insects myself, on different kinds of *Cácti*, in the establishment of M. Jacob Makoy in Liège, with the most perfect success, I can confidently recommend it as the most applicable and worthy of imitation. In one day, with the assistance of a boy, I purified a very considerable part of the rich collection of *Cácti* there. (*Garten Zeitung*, April 11. 1840, p. 118.)

ART. VII. *Notice of a new evergreen coniferous Tree, the Torrèya taxifolia.* By A. J. DOWNING, Botanic Garden and Nurseries, Newburgh, near New York.

I SEND you by the British Queen (in a box among some *sarracenas*, *dionæas*, &c.) what I hope you will consider a treasure, viz. a living plant of the beautiful new evergreen tree of Florida, which Dr. Arnott (*Annals of Nat. Hist.*, vol. i. p. 126.) has named in compliment to our distinguished friend Dr. Torrey, the first of American botanists. This is the first and only specimen that has yet been sent across the Atlantic. There are no plants of it in any other establishment in this country, and from the absolute impossibility of penetrating to its habitat in Florida, abandoned as that territory at present is to the ravages of the Indians, I fear that this most interesting new tree will be rare in botanic gardens for a considerable time to come. I trust you will receive this specimen in good condition, and that, after figuring it, you may be able to place it in a favourable situation for its future growth. As it comes from the North of Florida, there can scarcely be a doubt of its hardiness in the climate of England; and it will probably, therefore, in time prove a most valuable addition to the arboretum of Britain. I learn from Dr. Torrey, that his former correspondent in Florida, who collected the very

few living specimens we have (of which this sent is one), states that it is a rapid-growing tree, attaining the altitude of 40 or 50 feet, and forming a superb rich green pyramidal head of foliage. The latter you will perceive somewhat resembles that of the yew. But the general appearance of the tree, in a gardenesque point of view, is perhaps between that of the *Táxus baccàta* and our *Abies canadénsis*. I regret that I am only able to send a single specimen to England at present, but assure you it is quite the choicest botanical novelty in the country. — *A. J. Downing. Botanic Garden and Nurseries, Newburgh, near New York, Sept. 30, 1840.*

The plant, about 18 in. high, was brought to Bayswater on Oct. the 27th, in excellent condition; and, being afraid of neglecting so valuable a treasure, and besides wishing that it might be speedily propagated, we deemed it best to present it to our esteemed friend Alderman Masters, of the Canterbury Nursery, who, from his great skill and success in propagating rare plants, will, we doubt not, soon be able to produce some young torreyas for sale. The dionæa arrived in excellent condition, and also the sarracénias; and for the whole we are very deeply indebted to Mr. Downing.

We are also deeply indebted to Dr. Torrey, for we find by his letter, dated Oct. 1., that the plant we have received was his "only living specimen," and that, at the request of his friend Mr. Downing, he let that gentleman have it to send to us. Dr. Torrey also accompanied the plant with a section of the trunk of the tree, which we have also received. It is between 6 in. and 7 in. in diameter, and 1½ in. in depth, the grain much coarser than that of the yew, though finer than that of the *Abiétinæ*, unless we except *Pinus Cémbra*. — *Cond.*

The following notice respecting the *Tórreya*, is taken from Dr. Arnott's paper in the *Annals of Natural History*.

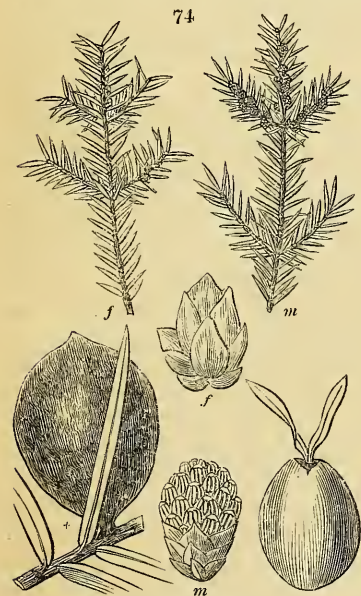

Torrèya taxifòlia Arnott in *Ann. Nat. Hist.* vol. i. p. 126., *Hook. Icon. Plant.* vol. iii. t. 232. and 233., and our *fig. 74.* and *fig. 75.* natural size; *Táxus montàna Nutt.*, but not of Willd.; *Taxínæ Richard*; is a native of Middle Florida, where it was discovered in 1835. It is so abundant about Aspalaga, that it is sawed into

planks and timber. "It differs from *Podocárpus* by the erect fertile flowers; and from *Táxus* by the want of the fleshy enlarged cup or disc in which the seed of that genus is immersed, and by the anthers being four-lobed and dimidiate, and inserted by a pedicel on an axis, which is at length elongated. It is a tree of from 6 in. in diameter, and from 20 ft. to 40 ft. high

with numerous spreading branches, the ramuli dividing trichotomously; its appearance at a distance is not unlike that of *Pinus canadensis*. The wood is dense and close-grained, heavy for one of this family, and in old trees of a reddish colour, like that of *Juniperus virginiana*; it is of a strong and peculiar odour, especially when bruised or burned; hence it is frequently called, in the country where it grows, "stinking cedar." It makes excellent rails, and it is not liable to the attack of insects. A blood-red turpentine, of a pasty consistence, flows sparingly from the bark; it is soluble in alcohol, forming a deep clear solution; when heated, it evolves a very powerful terebinthine but unpleasant odour. The foliage is much like that of *Taxus canadensis* and *Podocarpus taxifolius*, only the leaves are larger. The ripe fruit, or rather seed, is as large as a nutmeg, with beautifully ruminated albumen, the inflexions of the brown investing membrane penetrating through the white albumen about half way to the axis; a structure which alone will separate it from *Taxus*, nor, indeed, has it (so far as I know) been observed in any other of the family. There is no fleshy cup, but the external coat of the seed itself is fleshy, or rather leathery, and covers the whole, leaving a minute perforation at the summit. The seed, deprived of its succulent external covering, strongly resembles the gland of a large acorn, as well as the fruit of *Taxus nucifera* *Kæmpf.* figured in Richard's *Mem. on the Coniferae*, tab. 2. (*Ann. Nat. Hist.*, p. 129.)

ART. VIII. *On the Orange Groves of East Florida.* By ALEXANDER GORDON.

IN a communication to the *Gardener's Magazine* for 1828, p. 463., I recollect having made some remarks on the gratification I derived from viewing the luxuriance of the orange trees in East Florida. Having recently returned from exploring that country to a very considerable extent, probable more than ever was accomplished by a *Pale face* (according to the Indian phrase) before, I shall therefore trouble you with a few remarks on that subject, but more particularly as respects the city of St. Augustine, which has been long famed for its oranges, and with which I was so highly gratified on the 1st of Jan. 1828, as alluded to by you in the *Encyclopædia of Gardening*.

I may here remark that all over East Florida natural groves of the orange abound, but at St. Augustine the cultivation of that fruit was carried to a great extent, particularly by the Minorcain portion of the population. St. Augustine is one of the oldest, if not the very oldest city within the jurisdiction of the United States, and has long been a place of great resort for invalids afflicted by pulmonary and bronchial complaints. I had visited this city in 1828 and 1831, and I am free to confess I was in perfect raptures with its diversified beauties. It then appeared like a rustic village, the white houses peering from among groves of orange trees, which grew in the greatest luxuriance; the clustered boughs, covered with their golden-coloured fruit, yielding a rich harvest to the owners, and affording a delightful shade to the foreign invalid, where he cooled his fevered limbs, and imbibed health from the perfumed atmosphere, while the ear

was gratified and the feelings soothed by the various notes of that delightful songstress the mocking-bird: but alas! on my visit during the past spring (1838), in vain did I look for those rural bowers, so gratifying to the eye, and invigorating to the system. Not a single tree of any magnitude to indicate its former grandeur. The imagination could scarcely conceive such a perfect metamorphosis. For a long period the orange trees had flourished without interruption from frosts or other casualties. The city of St. Augustine was peculiarly favourable for this semi-tropical fruit. The soil is naturally sandy, but rich in calcareous and vegetable deposits, consequently well calculated for horticultural pursuits. For years the orange had become the staple commodity of the city's commerce; immense quantities were annually grown and exported. Numerous groves of young trees were planted, and 10,000 dollars had been refused for a grove consisting of only two or three acres. Extensive nurseries could scarcely supply the demand for young trees. A vast and lucrative field opened to the enterprising horticulturist. On the native orange were engrafted the choicest varieties of other climes. The Minorcain population had been accustomed to depend on the produce of their little groves of eight or ten trees to purchase their coffee and other necessaries from the stores (shops), so that, without either toil or care, their wants were amply supplied by the hand of nature, but

“ There came a frost — a withering frost.”

During the month of February 1835, East Florida was visited by a severe frost, much more severe than any before experienced. A cutting north-west wind blew ten days in succession, but more violently for about three days. During this period the mercury sank 7° below zero. The St. John's river was frozen several rods from the shore, and afforded the inhabitants a spectacle as new as it was distressing. The orange, the fig, and all kinds of fruit trees were killed to the ground. The wild or native orange suffered equally with those cultivated, at all events as far south as Lake George, which lies between 28° and 29° north latitude. The inhabitants of St. Augustine were thus deprived at one fell swoop of their chief dependence for support. But during my late visit to that city, I was happy to find they were not discouraged, for there were many thousands of young trees now ready for planting out, and in a few years more it is to be hoped St. Augustine will again exhibit its wonted appearance, and the citizens reap the reward of their laudable perseverance. The oranges grown here were considered decidedly superior to those imported from the West Indies, and as a long period has elapsed since they experienced so calamitous a visitation (I believe not since 1775-6), it certainly is worth while to persevere.

At a former period there was an extensive Botanic Garden here; it was enclosed by a formidable stone wall, and I believe was established by Governor White. This place now serves as a pen for a herd of swine; which, with the exception of a few decaying fruit trees, appear the only inhabitants of a spot once devoted to the choicest gifts of Flora.

In conclusion, I may remark, the city of St. Augustine is most pleasantly situated, two miles back from the Atlantic, near the southern point of a peninsula, and is almost surrounded by water; defended from the surf by Anastasia Island, which is just high enough to answer this end, but sufficiently low to admit the refreshing breezes and a view of the ocean. The situation is peculiarly serene, healthy, and pleasant. The climate is delightful; snow is almost unknown, and slight frosts in general are only felt for one or two months in the year, and I understood many winters pass without discovering the least symptom of frost. In the summer season the air is tempered daily by the sea breezes, while the land breezes render the evening cool and pleasant.

New York, Dec. 9. 1838.

REVIEWS.

ART. I. *Traité de la Composition et de l'Ornement des Jardins avec 161 Planches représentant en plus de 600 Figures des Plans des Jardins, des Fabriques propres à leur Décoration et des Machines pour élever les Eaux, &c.* 2 vols. oblong 4to, text pp. 223, and 1 vol. of plates. Paris, Audot, 1839.

THOUGH there is not much in this work that will be new to the English reader conversant with the literature of landscape-gardening and garden architecture, yet it contains such an assemblage of engravings of ground plans, elevations, and views, having reference to gardening and rural improvement, as is not to be found in any other work. In some respects it resembles the grand work of Hirschfeldt, so frequently quoted in the historical part of our *Encyclopædia of Gardening*, but it also includes much of what is contained in the *Ideenmagazin*, published in Leipsic between 1779 and 1805, and noticed in one of our early volumes. The letterpress contains, I. A Glance at the History of Gardens; II. Different Kinds of Gardens; III. Of Situations in general; IV. Of particular Situations; V. Of Climate and Temperature; VI. Of measuring Ground and taking Plans; VII. Of the Kitchen-garden and Orchard; VIII. Of Mixed Gardens; IX. Of Botanic Gardens; X. Of Symmetrical Gardens; XI. Of Florists' Gardens, and of a Rosarium; XII. Of Landscape Gardens; XIII. Of Gardens of great Extent, including a cosmopolite garden; XIV. Of Zoological Gardens; XV. Of a Cottage Ornée; XVI. Of a Ferme Ornée; XVII. Preparations for laying out a Landscape Garden; XVIII. Employment and Arrangement of Plants; XIX. Of artificial Perspective, including trees with obscure flowers, and trees with conspicuous flowers; XX. Evergreens; XXI. Of Water; XXII. Of Rocks; XXIII. Ornamental Constructions of different kinds, including hot-houses, dwellings of every kind, from the villa to the cottage,

bridges, ornamental structures, and structures for play, such as roundabouts, swings, &c.

The volume of plates is very neatly executed, and there is scarcely a gardening work of any note which has not been made to contribute to its enrichment. The plate which we like best is the view of the gardens of Levens Hall, Westmoreland, which forms the frontispiece to the volume of text.

ART. II. *Traité des Végétaux qui composent l'Agriculture, &c.*

Treatise on the Plants which are cultivated in Agriculture, Planting, and Gardening; containing the most striking Characters, the Points of Difference, and the Qualities and Uses of all Plants, more particularly those little known or deserving of Culture; followed by Considerations respecting Nurseries and Plantations, and a Monthly Journal of Work to be done in the Forest, the Garden, and the Farm. By C. Tollard aîné, Seedsman and Nurseryman, M.D., and Member of many Societies. Small 8vo, pp. 913; 2d edition. Paris, printed for the Author, and sold by him at his Seed-shop, Rue de la Pelleterie, and by Colas, Bookseller, Rue Dauphiné. 1838. Price 6 francs.

THIS may be considered as a similar work to the *Bon Jardinier*, but, inasmuch as it treats of a greater number of plants, it is in a botanical point of view more comprehensive. On comparing letter *A.* of the Index of the one with letter *A.* of the other, we find above fifty articles in the *Traité* which are not in the *Bon Jardinier*, and three or four in the *Bon Jardinier* which are not in the *Traité*. Nevertheless there is a greater quantity of matter in the *Bon Jardinier*, and perhaps on the whole it may be considered as less botanical, but more practical, that is, treating more at length of culture. Both appear to us excellent works, and well deserving of patronage. The paper on which the *Traité* is printed, and the type used, are both greatly superior to those of the *Bon Jardinier*, which is surely worthy of being put on a par with the *Traité* in these particulars.

ART. III. *Exposition de Fleurs et d'autres Produits de l'Horticulture et de l'Agriculture.* Pamph. 8vo, pp. 43, 2 folding and 2 octavo plates. Lyons, 1840.

AMONG the collections of plants noted as remarkable are, that of M.M. Charles Martin, Burdin, & Co., which contained 177 species; that of M. Nérard aîné, which contained 168 species; that of M. Adrien Sénéclauze, which contained 194 species; that of M. Guillot père, 254 species; that of M. Armand, 166 species; and a number of others. Several grafting instruments, garden seats, fountains, and some agricultural implements and plans of gardens, were exhibited, engravings of some of which articles are given in the plates. On the whole, the exhibition contained a great many plants, some of which, such as *Dammara*, would have been considered rare, and almost all of them valuable, in England.

The first plate exhibits the potato onion (*Allium Cæpa stérilis*), propagated by cutting the bulb across two or three lines above the plate, when a number of offsets are developed from the centre; the second and third contain some grafting instruments; and the fourth, views of garden seats, fountains, contrivances for *jeux d'eau*, vases for plants, and a *jardinière*, or box for plants, all in iron or copper. We have sent the pamphlet to Mr. Austen of the New Road, who manufactures fountains as well as statuary work, to afford him a chance of acquiring new ideas from it.

ART. IV. *The Flora of Yorkshire.* By Henry Baines, Sub-curator to the Yorkshire Philosophical Society. 8vo, pp. 159, two maps. London, 1840.

THE botanical riches of Yorkshire, the author informs us, "are little known to the public in general, though the county contains many rare species."

"It is not merely because of its large geographical area that Yorkshire is more rich in vegetable forms than most other English counties: its surface exhibits several distinct characters of soil and stratification, accompanied by gradations of elevation, from the sea-shore to mountains of 2400 and even 2600 ft. high; its climate varies accordingly; and it lies in such a geographical position as to unite, in a considerable degree, the characters of Scottish and English vegetation.

"The mean temperature of York, which is about 50 ft. above the sea, is very nearly 48° Fahr., and there is little variation in different parts of the county, except what unequal elevation above the sea occasions. The effect of this on Mickle Fell, the highest mountain in Yorkshire, may be estimated at 8° of Fahr., so that the extremes of mean temperature in Yorkshire vary from 40° to 48°. From similar data we may state the range of highest mean daily temperature, in the shade (in July), at from 54° to 62°; and the range of lowest mean daily temperature (in January) at 25° to 33°. The most prevalent winds are south-easterly during all the year, excepting about a month after the vernal equinox, when, in all the eastern parts, north-easterly winds prevail. The quantity of rain falling at York is 24 inches, and it is below the average of the county, of which the western parts are the most rainy.

"Of 1002 flowering plants noticed in the catalogue, only three are peculiar to Yorkshire, viz.:—*Arabis hispida*, *Dryas octopetala*, and *Juncus polyccephalus*.

"One not peculiar to the county, flowers no where else in England, viz., *Cornus suecica*.

"Twelve attain in Yorkshire their southern limits, viz.:—

<i>Actæa spicata</i>	<i>Ribes petræum</i> *	<i>Bartsia alpina</i> *
<i>Potentilla fruticosa</i> *	<i>Saxifraga umbrosa</i>	<i>Rhinanthus major</i>
<i>Rosa sarmentacea</i>	<i>Saxifraga hirculus</i> *	<i>Trientalis europæ</i>
<i>Sedum villosum</i> *	<i>Gentiana verna</i> *	<i>Tofieldia palustris</i> *

"It is interesting to observe that of these the greater proportion, marked by the asterisk, occur only in the most northerly and mountainous districts of the county."

There are in Yorkshire "six principal physical regions, which correspond to as many great groups of the subjacent mineral aggregates. Several of these may require further subdivision; as, for example, the great central vale, from which the low terrace of magnesian limestone which limits it on the west may be separated. We must also notice the line of sea coast, and thus we shall have eight botanical divisions, viz.:—1. The North-Western or Mountain Limestone district. 2. The South-Western or Coal district. 3. The Magnesian Limestone tract. 4. The great central Vale. 5. The North-Eastern or Oolitic Hills. 6. The Chalk Wolds or South-Eastern Hills. 7. The district of Holderness. 8. The Sea Coast."

These extracts will show the very interesting nature of the work before us, which may be characterised as one of the most scientific local British Floras yet published.

ART. V. *Every Lady her own Flower-Gardener.* Addressed to the Industrious and Economical only. By Louisa Johnson. 12mo, pp. 136 3d edit. London, 1840.

COMPILED, the authoress informs us, for many of her companions who require a work in a small compass, not deluged with Latin words and technical

terms. I have endeavoured, the fair authoress says, "to meet their views; and my plan of Floriculture may be carried into effect by any Lady who can command the services of an old man, a woman, or a stout boy." We are happy to find that so meritorious a work has already arrived at a third edition. Every author and publisher knows that this is worth a page of eulogium.

ART. VI. *The Eastern Arboretum, or Rural Register of all the remarkable Trees, Seats, Gardens, &c., in the County of Norfolk.* By James Grigor. Illustrated by drawings of trees, etched on copper, by H. Ninham. Nos. II., III., and IV. 8vo, 9 plates. London; July, August, and September, 1840. 1s. each.

(Continued from p. 601.)

OUR Trees.—No. 1. *The British Oak.* *Quercus Ròbur L.*, the *Quercus pedunculàta* of Willd. and *Arb. Brit.*—Out of much that is interesting on this tree, we quote the following passage:—"Various opinions are abroad respecting the best mode of forming forests of oak; some maintaining that it is indispensably necessary, in order to preserve the native vigour of the tree, that plantations, if possible, should be sown, whilst others recommend the ordinary practice of planting. We are aware, from experience, that frequent transplantation has a tendency to subdue and soften that rigidity of fibre which all young trees possess: in the case of the crab-tree, it lessens the sharpness and sourness of its fruit; and it is well known that in Spain and Portugal, where large plantations of the chestnut are made, the practice of frequently shifting the trees is resorted to, for the purposes both of checking their growth and freeing the nuts from that woody taste which they otherwise have. It ameliorates and subdues the wildness of their native character, and it must have a corresponding effect on the texture of their timber. But, notwithstanding all this, our conviction is, that, if a tree is transplanted finally before it loses the power of forming to itself a new taproot, as it is called, it is immaterial whether it rise in the forest from seed or plant. An oak, for example, that is planted and replanted often in the nursery, before being placed in its final destination, has a bushy, matted root, and has no such power: it will never shoot up vigorously; the top, in sympathy with the root, will break into numerous branchlets and form a round-headed tree. Great care must therefore be taken to give every encouragement, by pruning, to the principal shoot, in order that it may have always a decided ascendancy over the others."

Our belief is, that trees so circumstanced, after being removed to where they are finally to remain, and firmly established there, and cut down to the ground, will throw out a taproot, and become in all respects as vigorous as if they had been raised on the spot from the acorn.

A Day at Thorpe, &c., "the Richmond of Norfolk."—"Altogether, this place reminds us of some of those delightful scenes met with about the great metropolis of England, especially in the neighbourhood of Kensington and Bayswater. Notting-Hill and Camden-Hill are very like Thorpe; the villas are of the same style, and the inhabitants of a similar grade—men generally of refined taste, who carry their wealth out of the city with them, and beat it out at leisure, not in embroidered gold, but in the shape of gardens, trees, and flowers; objects in which there is a lasting heartfelt satisfaction, which rise around them in after years, speaking a language in which there is nothing that reproaches, which tells them that there is, after all, something good in the human heart, and that their labour has not been in vain." We must pass over the remainder of this delightful chapter, which describes the seats of Col. Harvey, Col. Money, Captain Blakiston, C. Jeeks, Esq., J. Postle, Esq.,

the Rev. W. Frost, C. Weston, Esq., Sir W. Foster, the Rev. G. Stracey, G. D. Gardiner, Esq., J. Kitson, Esq., N. Micklethwait, Esq., T. T. Berney, Esq., Misses Lloyd, H. Custance, Esq., and some others. We shall only give the dimensions of one or two of the largest trees, viz., a pinaster, usually called a stove pine, 60 ft. high, with a trunk 10 ft. in circumference; a yew, $5\frac{1}{2}$ ft. in circumference; *Pópulus canéscens*, $11\frac{1}{2}$ ft. in circumference; an oak, with a trunk $16\frac{1}{2}$ ft. in circumference, and another $19\frac{1}{2}$ ft. in circumference, with its branches spreading over a circle of 102 yards. An engraving is given of a silver fir 85 ft. high, with a trunk 4 ft. in diameter.

Our Trees.—No. 2. *The Wild Pine.* *Pinus sylvéstris.* — Mr. Grigor is here more than usually eloquent and instructive; his brothers, the highly respectable nurserymen of Elgin and Forres, being extensive dealers in the seed and plants of the true Highland variety of this most useful of all European trees. An engraving is given of a specimen at Keswick, the seat of H. Birkbeck, Esq., which has a trunk 12 ft. in circumference, clear of branches to the height of 30 ft., with a wild branching head, “like its kindred on the sides of the Norwegian or Highland hills.”

Holkham Park, the Seat of the Earl of Leicester. — “Long before reaching the hall, you enter by one of the many magnificent gateways, which ushers you at once into scenes which ordinary people take care to have grouped immediately around their dwellings. A profusion of exotic plants decorates the walks on each side.” This appears to be more in the French style than any thing we recollect to have seen in England; and as far as we can decide, without being on the spot, we should say it is in bad taste, for reasons which we shall give when speaking of French villas. In describing Holkham, justice is done to the enlightened liberality of its proprietor, who may truly be said to be universally loved and admired.

“On approaching the Hall, the scene partakes of that heavy grandeur which time usually bestows on old plantations. . . . Who can look abroad on this rich domain without priding himself on his national character, that there should be found in our land spirits so far ennobled above the common throng, as to prepare for posterity such an inheritance as this is? Let it be remembered, that it was not the aiding of Nature, but her total subjugation, that had to be accomplished before this place was brought to its present perfection; the country here being once a cheerless barren desert,—she had to be overcome, and led out in a way which she knew not before; and, certainly, every trace that we can discern of her having been so conducted, bespeaks the guidance of a masterly hand. We at once associate such work with the best efforts of philanthropy. It is far removed above every thing pertaining to earthly titles and orders. It is the work of good men; and, though we may run the risk of being accounted an enthusiast in those matters, we maintain that there is a heavenly-mindedness, even, pervading such employment, which the ordinary objects of fame are but indifferently endowed with. What are all the triumphs of man over man, carrying only death and desolation with them, compared to this peaceful conquest of country, leaving it stored with life, and rich in arborescent grandeur? The simple announcement inscribed over the entrance of this Hall is, that ‘This seat, on an open barren estate, was planned, planted, built, decorated, and inhabited in the middle of the eighteenth century, by Thomas Coke, Earl of Leicester.’”

Among the remarkable trees are, *Pópulus canéscens*, a magnificent specimen, of which an engraving is given; several very large and old oaks, with trunks averaging 16 ft. in circumference, and from 65 ft. to 70 ft. high; an elm 14 ft. 6 in. in circumference; many specimens of *Quércus Ilex* “celebrated all over England” for their magnitude and beauty; some having trunks $12\frac{1}{2}$ ft. in circumference, with branches overspreading a circle of 54 yards. Common oaks, planted by the present proprietor, now measure 8 ft. in circumference; a mulberry, in the kitchen-garden, trained against a wall, extends over a space of 101 ft.; “but, in order to induce the tree to produce fruit, the younger shoots have been shortened of late years.” We pass over nume-

rous interesting passages to give two sentences from Mr. Grigor's conclusion. "In our opinion, then, this eastern dwelling has no rival, either at home or abroad, to which in any respect we can compare it. It stands alone, a monument of English opulence and taste."

Our Trees.—No. 3. *Bétula álba* and *B. a. péndula*.—The proper province of this tree, Mr. Grigor remarks, "is amongst rocks and ravines, or by some glassy stream far away from the haunts of men; for we can never bring ourselves to think that it appears at home beside our dwellings." In this sentiment we concur, and the reason is, that, like Mr. Grigor, we have been in the habit of seeing the birch in its native habitats in mountainous countries, and the associations thus established in the mind are so peculiar and so strong, that we never have been able to consider the common birch a fit inhabitant of ornamental grounds of any description. Persons who are natives of the level fertile country of England, we know, have no such associations.

"The most remarkable trees of the weeping species in Britain are grouped about the Findhorn, a noble and rapid river near to Forres, in the North of Scotland, where the tree rises to the height of from 60 ft. to 70 ft., and girting on an average about 11 ft. Some of the branches of those trees display pendent masses of spray 10 ft. in length, adding a graceful variety of verdure to scenes in themselves of great beauty."

"We are sorry to banish such an object from our homes; but it cannot, with any propriety, be introduced in our cultivated lawns. It has little fellowship with other trees: even with the weeping willow, a tree which in many respects it resembles, it forms a very unsuitable companion. It seems as if Nature had peculiarly designed this tree only to fill up scenes which, in her haste, she had left in an unfinished, or rather in a rugged state; for it is in such places exclusively that we naturally find it."

"There is no tree which, when fairly started, will so completely overcome the evil effects of greensward, weeds, hardness of soil, or the usual results of negligence in rearing timber. This arises from an admirable provision of nature, in having formed its bark much harder, or at least more durable, than its wood. It is peculiarly, then, the tree of the waste and the desert, where it may be planted and left to contend successfully with all adverse circumstances."

Stratton Park, the Seat of Robert Marsham, Esq.—This place, celebrated for upwards of a century, on account of its plantations of oaks, pines, and most other kinds of trees, Mr. Grigor justly observes, may be characterised as "the Arboretum of Norfolk." R. Marsham, Esq., F.R.S., grandfather to the present proprietor, was born in 1707, began to plant before he had attained the age of manhood, and died at the age of 90. It is easy to conceive, that, under such circumstances, Stratton Park must be covered with magnificent trees, and such, indeed, is the case, as appears both by the dimensions given in our *Arboretum*, which were sent us by R. Marsham, Esq., the present proprietor, and by the more numerous details in Mr. Grigor's work. To this work we must refer the reader, though we cannot resist the temptation of giving one or two dimensions. A cedar of Lebanon, planted when 1½ ft. high, in 1747, has a trunk of 44 ft. high free from branches, which measures, at 2 yards from the ground, 12 ft. 2 in. in circumference. The height of this tree, which is one of the handsomest in England, is 79 ft., and it contains 10 loads of timber. A silver fir is 105 ft. high, another 104 ft.; a spruce fir 95 ft.; a common holly 60 ft., with a trunk 5½ ft. in circumference, and 25 ft. in length; a sweet chestnut 75 ft. high; a weeping birch girting 14 ft. 10 in., "a noble and graceful object;" a beech, of which an engraving is given, has a trunk 6 ft. in diameter at 1 ft. from the ground, and a head which covers a space of 104 yards in circumference. After paying a just tribute to the trees in general on this estate, Mr. Grigor observes: "We sometimes wonder why it is not general amongst our public societies devoted to improvement, either to offer prizes for the finest trees upon our lands, or

appoint judges to report upon the appearance of our various estates, — a mode of distinguishing betwixt the diligent and careless in those great matters, which could not fail to be attended with beneficial results. In our opinion, then, the planting of trees forms the best of subjects for rewards. We have been led to make these remarks simply from seeing so many fine old trees together, and the high state of culture the young ones upon this estate exhibit, great care having been evidently bestowed upon them as to their selection, pruning, and the distances at which they stand from each other, so as to admit the free air amongst their leaves. The trees here, from their displaying such grandeur, are creating a taste for such objects amongst some of our proprietors in this neighbourhood; and we trust that when an arboretum shall have become an indispensable accompaniment to every country seat, this feeling will be still more extensively promoted.”

Trees of Hevingham, Aylsham, &c. — Around the ancient church of Hevingham there are some magnificent old trees of the sweet chestnut in the decline of life. Mr. Grigor mentions the tradition of a forest of sweet chestnuts having formerly existed in the neighbourhood of the metropolis, but on further research he will find that the trees and the timber believed to be chestnut was the chestnut oak (*Q. sessiliflora*), which is still the indigenous species of oak to the north of the metropolis, and the grain of the wood of which bears a close resemblance to that of the sweet chestnut. In truth, the timber of the sweet chestnut, after the tree has attained a diameter of 18 in. or 2 ft., is seldom fit for any thing but fuel. The wood, when young, however, is durable, and is much used in England for hop-poles, and, when large, for gate-posts; in France, for props to vines, and, split into laths, for trellis-work to fruit-walls, and for trellis fences. Laths of young trees, from 6 in. to 10 in. in diameter, unpainted, will last as trelliswork for 10 or 12 years. Speaking of the seat of the Rev. Mr. Bulwer at Aylsham, “a place which exhibits many works of a fine taste,” a sweet chestnut is recorded as 7 ft. 2 in. in circumference, with a beautiful regular head, which was raised from a nut planted 38 years ago. The soil here is very favourable to the growth of trees, and “eminently adapted for a private arboretum. It might be commenced with a collection of the various species of *Cratægus*, *Pinus*, *Pavia*, &c., and extended by degrees until a specimen of each of our finer trees was included in it. As already observed, we firmly believe that the day is not very distant, when all our landowners will generally betake themselves to the work of forming arboretums, and, consequently, of perfecting their estates by planting. The establishment of arboretums all over the land will be productive of two grand results, — the improvement of our country and climate. There will then be a sort of millennial perfection arrived at. The barren districts will rejoice in plenty, and the parched wilderness will bear the luxuriant spreading evergreen. The seasons of Italy will be transferred to England, and England’s warmth and genial clime will be felt within the wintry North.”

In conclusion, we cannot sufficiently recommend this work as one of instruction and entertainment, not only to the inhabitant of Norfolk, but to all lovers of nature, gardens, and trees. With Mr. Grigor, “we pity the man who displays no fondness for trees — who inquires not after them at all; because he is robbing himself of one of the greatest sources of enjoyment that nature has placed within the reach of the human kind.”

ART. VII. *Monographie du Genre Camellia, &c.* A Monograph of the Genus *Camellia*, and a complete Treatise on its Culture, Description, and Classification. By the Abbé Berlèze. 2d ed. 8vo, pp. 237, 4 coloured plates. Paris, 1840. Price 5 francs.

THE first edition of this work was noticed with commendation in our volume for 1838, p. 290., and we there also gave a summary of the author’s mode of

classification and description. This second edition contains 17 new articles on culture, and more than 200 descriptions of new varieties. The total number described in the work is 508, all of which are in possession of the author, and cultivated by him in the Rue de l'Arcade in Paris, to a very high degree of perfection. This we can testify, having seen them, in company with the author, in July last. Besides these 508 named kinds, the Abbé has numerous seedlings which have not yet flowered, and which will furnish food for new names, and future editions of the *Monograph*. The work has been in extensive demand both in Europe and America, and has been translated into English, German, and Russian. More in its favour it is unnecessary to say.

ART. VIII. *A Treatise on Agriculture and Dairy Husbandry*. By James Jackson, author of various Prize Essays of the Highland and Agricultural Society of Scotland. 8vo, pp. 116, numerous woodcuts. Edinburgh, copyright work published in connexion with People's Editions by W. and R. Chambers; London, Orr and Co.; 1840. 2s. 6d.

THIS is an epitome of the whole art of British field culture, drawn up with great skill and care by an author evidently well acquainted with the literature of agriculture, as well as its science and practice. We can safely venture to affirm that there is no modern work on the same subject so good and so cheap.

MISCELLANEOUS INTELLIGENCE.

ART. I. *General Notices*.

The skilled Gardener rises in his position and means as horticultural science multiplies its inventions. The gardener who was once a mere labourer becomes the director of labourers. The work of his hands diminishes, and that of his brain increases, and brings him a better remuneration. He is advanced above his poor fellow-labourer, whose bones and sinews have to compete with the spade, the mattock, and the wheelbarrow. The unskilled gardener has to stand the brunt of ceaseless improvements and changes, which press him downwards, while they heave others upwards. It may still be the fact that the condition of the labouring gardener is much above that of his forefather; but, then, how changed is the whole state of society! If absolutely better, he is comparatively worse. And, moreover, if he be not educated in the mode that would most benefit him, there is a kind of education continually going on which is not lost upon him. There ought not to exist in this country a numerous race of unskilled gardeners or labourers of any description. So long as it does exist, we are treading upon gunpowder. The permanent safety of society, through all its ranks, and in all its institutions, is contingent upon the instruction of the poorer classes. Everyone should be put in training to become a skilled, instead of an unskilled, labourer, by which alone he can be put in the way to avail himself of that common heritage of improvement from which he is now excluded. (*Morn. Chron.*, Sept. 10. adapted.)

Preservation of Grain or Seeds.—At the Academy of Sciences, Paris, July 28th, M. Granier addressed to the Academy an explanation of his method of preserving corn for long periods. The corn was well winnowed, and put in a vessel or room perfectly free from damp, the external air excluded, and then sulphuric acid introduced by means of burning sulphur within, as is done in this country for whitening peeled wickerwares. If many insects should be found to be destroyed by this method, pulverised charcoal should be mixed with the corn to obviate the effects of putrefaction. M. Granier had kept corn

six years perfectly good by a renewal of this operation once a year. (*Literary Gazette*, August 1. 1840.)

Pumpkin Sugar. — M. L. Hoffinan, in Hungary, has procured a patent for the manufacture of sugar from pumpkins, and he and M. Emeric Devay have established a small manufactory of the article in Zamdor, in which they have already obtained 40 cwt. of sugar from pumpkins, a small part of which they have also refined : 1 cwt. of pumpkins yields as much sugar as 1 cwt. of beet-root ; but the space of a hectar, viz., 2 acres, 1 rood, and 35 perches, yields three or four times more pumpkins (according to the weight) than beet-root, the space occupied by the Indian corn growing between the rows not being included. 8 cwt. of sugar could be raised on 1600 square toises, from which a weight of 200 cwt. of pumpkins is obtained, and sometimes even 260 cwt. of pumpkins. M. Hoffman has obtained from between 26 and 27 cwt. of pumpkins, 1 cwt. of sugar, and as much syrup. In making the sugar, the pumpkins are cut in pieces, and then with the rind are rubbed on a grating, the same as is used for beet-root : and the seeds, which produce an excellent oil, are kept separate. 1 lb. of oil is obtained from 5 lb. of seed. The juice is obtained from the grated pumpkins in the same manner as from beet-root. M. Hoffmann obtained from an indifferent press 82 lb. of juice, containing a proportion of sugar of from 3° to 10°, according to Bauncé. This juice is far preferable to that of beet-root, because it does not so soon lose its virtue, but remains good for 24 hours. It is purified and cleared with animal matter, and the pumpkin juice is boiled in the same manner as that of beet-root. Every machine intended for the above manufactory should be so constructed as to cut the pumpkins to pieces before they are grated.

Sheep prefer the refuse of the pumpkin to that of beet-root, which requires a well-cultivated soil, while the former will thrive on one that is less so. The beet-root is calculated for the north, and for moist atmospheres, and the other is more adapted for the south. In the French colonies, and in the Isle of Bourbon, a kind of pumpkin is found which produces much more saccharine matter than our most esteemed sorts ; but it cannot be compared to the sugar-cane, which has the inestimable advantage of producing fuel for boiling its own juice.—*M. Holst. Moscow.* (Translated for the *Gardener's Magazine* by J. L.)

The Bokhara Clover. — The small packet of seed which you presented to the Marquess of Northampton in 1839 was equally divided between our gardener and myself. I had my portion of the seed set singly, at a yard apart, in rather poor stiff soil, in His Lordship's private nursery. Above forty plants came up, and about half of these were eaten off, while in the seed leaf, by some species of insect. From the rapidity with which the seedlings disappeared, plant after plant, I apprehend that if this clover shall ever come to be raised from the seed in England as an agricultural crop, much disappointment will be experienced on account of its seeming liability to the attacks of insects. The greatest height which it attained with me, during the first summer (1839), was from 5 ft. to 6 ft. But I must observe here, that, long before it reaches this height, it becomes so hard and woody as to be totally unfit to use as fodder for cattle. When planted out singly, as my plants were, the habit of growth is rather elegant. From the main stems, which are numerous, proceed a profusion of irregularly situated lateral stems, which, as well as the main ones, terminate in a flower spike ; and again these laterals are furnished with numerous lateral flower spikes, and still the plant does not look confused or crowded. The average length of the spikes is from 5 in. to 8 in., and each spike supports from sixty to eighty small white and scentless papilionaceous flowers ; but, if a handful of the stems, when in flower, are cut and left in the shade for the matter of two days, a strong agreeable smell is emitted, exactly resembling that of *Anthoxanthum odoratum*. During the past summer, my plants grew 8 ft. to 10 ft. high : those in the gardens at Castle Ashby, where the soil is much richer, reached from 10 ft. to 12 ft. in height. Towards the commencement of last winter, I discovered that this plant was not an annual, as I had supposed, and therefore

I determined on allowing half a dozen of the roots to take their chance in the ground for the winter, without giving them any protection. They began to shoot forth very strong, and very early in the spring. In fact, some shoots were 1 in. long by the middle of December, looking through the ground not unlike asparagus in the spring. With me, the stems were 1 ft. long before the common red clover began to show signs of vegetation.

Should the Bokhara clover ever come to be useful in British agriculture, no advantage need be expected from it if allowed to grow to its full height, which is reputed to be 16 ft. The advantage will be found in the frequency with which it may be cut, and the weight of the crop, which must be very great. In the gardens at Castle Ashby, we had a row of the plants cut down four times, each cutting being from 18 in. to 2 ft. high; and, even now, a fifth cutting may be had taller than any of the former cuttings, only it is more woody and more covered with flower.

I have saved from six plants, this summer, 3 lb. of good seed, and I think there is nearly as much at the gardens. Seed, however, will be of little consequence, as the plant may be struck from cuttings in any number in the open border, without shade or shelter. I made six to seven hundred cuttings in August, and they have mostly rooted, and put out shoots, more than 20 in. now, and are all in full flower.

The shoots when young, and not more than from 2 ft. to 3 ft. long, are strong, and very succulent. I have tried horses and cattle with it several times, but they do not seem to relish it, leaving it for almost anything that is green. It is but fair, however, to say that my trials were made only after the plants had commenced flowering, and I believe, if it were cut and given before it gets too rank to the taste, they would not refuse it. My attention was at first attracted to the Bokhara clover only on account of the great height it was said to grow to, 16 ft.; and, as it only came to little more than half that height with me during the first summer, I felt disappointed, and became quite careless about it altogether. However, upon finding out that it was at least biennial, and, further, when I found such a quantity of succulent vegetable matter produced so early in the spring, I began to consider whether it might not be of some advantage to the sheep farmer. In the course of next season, from my present stock of plants, I shall have ample opportunity of ascertaining more fully the properties of the new vegetable, meanwhile I should be glad of any advice as to the best mode of cultivation. — *J. Munro.*

ART. II. Domestic Notices.

ENGLAND.

EFFECTS of the Winter of 1837-8. — I have been much interested with Dr. Lindley's masterly and well-arranged paper (p. 475.) on the "Effects of the Winter of 1837-8." Cultivators of trees and shrubs ought to consider themselves much indebted to him for the extensive information which it contains, and also for the systematic mode in which it is conveyed. It appears from this, as well as other accounts, that plants suffered much more about London, than they did in this neighbourhood, during that memorable winter. Most probably they were more excited by the previous mild weather, than ours were in Lancashire. For the future this may be guarded against, in a great measure, by placing all plants not perfectly hardy in such a situation as will give them the full benefit of sunshine in summer, but shade in winter, and shelter from storm throughout the whole year. The last is an all important requisite, as we can all testify, who experienced the dreadful effects of the hurricane of Jan. 9. 1839 upon all exposed plants, but more particularly upon the evergreens within its fierce sweep. A large bush of *Photinia serrulata*, in my garden, lost most of its leaves in that storm, and in spring the extremities of most of the branches were found to be dead for the length of 9 in., though not a twig of it was killed in the preceding winter. If the Horticultural So-

ciety would raise before their conservative wall a screen of hardy evergreens, of the height requisite for giving the required shade and shelter to the tender shrubs trained upon it, they would find themselves benefited by it on the occurrence of another severe season. Shrub and tree nurslings so situated would be in a great measure proof against a sudden fall of temperature, the screen before the sun guarding against unseasonable excitement as effectually as any high and breezy locality, and furnishing shelter at the same time.

If I recollect rightly, you have somewhere [?] spoken of the sun shining in winter time upon the plants trained on the conservative wall in the Horticultural Society's Garden as being beneficial, but I beg to correct you on that point; and, had you been here in 1838, my garden would have furnished you with reasons for submission under the correction, particularly by means of camellias and *Edwárdsia microphýlla* with a cover over head, and *Ligústrum lúcidum* without any sort of cover or protection, but sheltered both from winter sun and storm. The latter plant has now a flower spike upon it. *Edwárdsia chilénsis*, though well protected, but not similarly to *E. microphýlla*, died.

I hope you will give us a chapter on the winter of 1837-8, in your intended supplement to that work by which you are to be known hereafter: need I name the *Arboretum Britannicum*? I read it, as it appeared in numbers, with unwearied attention, and I remain your debtor for the information acquired.—*R. Tongue. Forton Cottage, near Lancaster, Oct. 18. 1840.*

Curtailing the alleged Species of Herbaceous Plants.—I wish Dr. Lindley or yourself would exercise the same assiduity with regard to curtailing the number of species of herbaceous plants, as you have praiseworthy employed in diminishing the species of shrubs and trees. I am sure there is much necessity for the labour in the *Aster*, *Saxifraga*, and *Delphínium* families. I see *Delphínium mesoleucum* ranks as a species in the specimen page of Paxton's *Pocket Dictionary*, which appeared in your review of that work; your *Hortus Britannicus* also gives it the same rank: yet it does not come true from seed. Whilst on this subject, let me say that *Viola flavicórnis*, which is suspected to be only a variety of *V. canina*, is not deserving of such suspicion, and appears to me not to merit degradation; on these grounds, that it flowers later, by a month or so, than *V. canina*, and disappears entirely in the winter, which is not the case with *V. canina*, its stems and part of the leaves, at least, being visible in winter. I have grown two plants of *V. flavicórnis* in my garden two or three years; plants which I collected from Ros-sall Warren, near the new town of Fleetwood, at the mouth of the Wyre; and of *V. canina* I have had too many plants, and am now discarding it as a nuisance. So you see I have had ample means of comparing the two.—*Id.*

The Crop of Apples in this neighbourhood has been unusually large, and, as far as I can judge from travelling 150 miles to the west, fully equal throughout the country. The load is so great as to require props to support the branches. The apple bigglers bought the orchards in a lump, not thinking it worth while to measure them. I have heard that inferior apples were so low as a shilling a sack.—*R. Lowndes. Binfield, Berks, Oct. 26. 1840.*

Quercus pedunculáta.—Have you remarked that one species of oak has been covered with acorns, I mean that growing upon a long stalk; whilst on the short stalk there are few or none. I noticed it very distinctly in the New Forest as I passed along, but here, where we have only those two kinds in common use, the fact is indisputably so, though in Billingbear Park I observed some of the short stalks with a tolerable crop of fruit, but the acorns very small.—*Idem.*

ART. III. Retrospective Criticism.

NAKED Barley. (p. 312.)—I send some observations that have occurred to me on perusing the article (p. 312.) on naked barley. The fate of the naked species of barley (of which there are several) is a singular one. They are

decidedly superior to the covered barley with respect to the quality of the grain; an equal measure weighs about a fifth more. The absence of skin must render the meal sweeter and better; in short, every body agrees in praising them, and yet they have never been brought into general cultivation. I speak at least of France; two species, the large with two rows, and the small, or celestial barley (*orge céleste*), have for a long time been tried and recommended, and I know of no locality where they have become market grain. To what must this be attributed? Is it only to the force of habit, and to the difficulty which, often without any other reason, new things find in obtaining a place beside the old, or have these sorts of naked barley any obvious defect which may have prevented their adoption? I am inclined to believe that both causes have had their effect here; but I cannot decidedly settle the question. Though I sow every year a certain extent of these species for the commercial collection of the house, I have never compared them sufficiently exactly with the common barley, to judge with certainty of their respective merit. These crops have, however, furnished me with some ideas, which I now communicate to you.

The large naked barley, or naked two-rowed barley (*orge nue distique*), (that to which the article in the *Gard. Mag.* refers), is the largest in the grain of the naked sorts; the ear is fine, long, and well filled; it is the earliest sort of barley, and perhaps of all grain. Opposed to these qualities it has some defects: the straw, scarcely so high as that of the common barley, is less strong in the stalk; it is subject to fall over, and to shed its seed, and to become entangled, which renders mowing very inconvenient, and causes loss. But the greatest disadvantage consists in the difficulty of thrashing; the grain adheres so strongly to the axis that it can only be separated by the strokes of the flail; and the straw after this operation is broken and good for little. An eminent agriculturist, the late Marquis of Barbançois, author of a small volume full of good observations, says that he has rejected this naked barley on account of this defect, notwithstanding its other advantages. In the part of Berry where he resided (the neighbourhood of Buzançais), barley straw is considered the best of all for horses, and reserved for their fodder. This was certainly a great disadvantage in the naked barley; in richer districts, where this straw is in less estimation, the detriment may not be so great.

The small species, or *orge céleste*, is also difficult to thrash, but less so than the preceding; the grain is smaller, fairer, and more delicate. It sends up many shoots; the straw is higher than that of common barley, larger, and firmer in the ground. From these qualities it seems to be superior to the preceding species, but it is more tenacious of the quality of the soil. In a middling soil, part of the ear cannot escape from the sheath, and is abortive. It has besides the defect of reproducing for a long time successive shoots, so that there are some quite young and herbaceous at the root when the first stalks are ripe. Notwithstanding this, good crops have been obtained, and I think on the whole it is a good grain. About twenty-five years ago this species was very much increased and noticed, in Belgium, under the names of *Blé de Mai*, *Blé d'Egypte*, and *Blé de Cent Jours*. The cultivation of it was then encouraged by the government; I do not know if it has kept its ground since.

I have also tried the barley of Nepal, or trifurcate barley, in the fields for some years, so remarkable for its singular ears without beards. The stalks are extremely thick, the leaves very broad. The grain is shorter, and not so fine as that of the two preceding species. In 1838 it yielded a produce equal in weight to that of common barley. I do not yet know what to think of it. I understand from Mr. Lawson, that in Scotland they were tolerably well pleased with it.

I shall conclude by enumerating the different species and varieties with naked grains which we now possess:—

1. The large naked barley (*Hórdeum distichum nudum*).
2. The small, or celestial, barley (*H. vulgare nudum*; *H. cœléste* Linn.)

3. The naked barley, *Risso*. Straw shorter than the preceding; ear yellow; grain rather larger, shorter, of the consistency of that of the large naked barley. I received it from the late M. Risso, under the name of Orge céleste, but it differs considerably from that of the North.
4. The barley of Guimalaye (in Taurida). Fine ear similar to that of *H. vulgare vérnum*; straw of a good height, ripens earlier than that of orge céleste; grain greenish. It was lately given to me by M. Pepin, Principal of the School of Botany at the Jardin du Roi, and appears to be very good.
5. The barley of Guimalaye, with purple grain, Sub-variety of the preceding; the same origin.

These three varieties (3, 4, 5.) belong, like No. 2., to the species *H. vulgare Lin.*

6. The barley of Nepal, or trifurcate (*H. trifurcatum Ser.*).

Besides these some new varieties have lately arrived at the Jardin des Plantes, among seeds received from Abyssinia. A portion of each has been sent to us. We shall sow them next spring.

You will see that there is room for further study and experiments, in order to arrive at the exact appreciation of the merit of the naked barley in general, and of the different species and varieties in particular. A great number of trials have been made on Nos. 1 and 2., but the greater part of them have not been followed up sufficiently, and very few of the statements have been laid before the public.

The great fault of almost all has been the not bringing one or more of the old species into comparison. This would be the only means of obtaining ideas on the subject, perfectly useful and satisfactory to the minds of practical men. — *Vilmorin. Paris, Sept. 1840.*

ART. IV. *Queries and Answers.*

THE Cause of Curl in the Leaves of Vines. (p. 568.)—A subscriber at Knightsbridge (p. 568.) wishes to know the cause of the curl in the leaves of vines. Whenever vine leaves flag, they are sure to curl afterwards, as the sap is stagnated, and the veins of the leaves get contracted when in a drooping state; and the sap being checked causes a curl and rough surface all over the leaves. The flagging of vine leaves is caused in many ways; viz. from the roots being injured, from vineries being kept too hot when the leaves are young and tender, and the sap being excited so as not to be able to supply all the wood; from heavy cropping, or from keeping too much wood in the vines. — *William Wilson. Blagdon Gardens, Northumberland, Oct. 14. 1840.*

ART. V. *Biographical Memoir of Charles Augustus Skell, Intendant of the Royal Gardens of the Kingdom of Bavaria.*

DIED on the 10th of July, 1840, in consequence of an apoplectic fit, Charles Augustus Skell, garden director of the kingdom of Bavaria. The name of Skell is so celebrated among landscape-gardeners and friends of gardening, and the deceased has, himself, contributed so much to support and extend the same fame, that a short notice of his death cannot be out of place in your interesting pages.

Even to the fourth generation the family of Skell has distinguished itself in gardening, and the application of its principles; and for nearly a hundred years, the grandfather, grandchildren, and great grandchildren have been celebrated in this branch of knowledge by their services to the chief of Bavaria. The deceased's uncle, Frederick Lewis von Skell, effected the most for the art, at a time when the nation showed a disinclination for the old French style of gardening; and he, by renewing it, and particularly in the South o.

Germany, produced a most æsthetical effect in the art of landscape-gardening. Munich is indebted to him for its beautiful gardens; the English garden, the garden at Nymphenburg, Biederstein, and the improvements in the Royal Gardens; and his name will ever live in the grateful recollection of the public generally, as well as in the hearts of his professional brethren. If these have not had opportunities of displaying their talents in similar great undertakings, arising either from political changes or other circumstances, they have always remained faithful to the prototype of their master and friend; and, by more fully establishing and extending his principles, have, to the present day, creditably supported one of the most beautiful and comprehensive departments in the art of gardening. Much of this merit is due to the deceased. He was born in 1794 at Karlsberg, near Zweibrücken, where his father, Matthew Sckell, was gardener to the Duke Charles of Zweibrücken, and towards the end of the last century came to Munich, when the king, Maximilian Joseph, succeeded to the electorate of Bavaria. His father was appointed head gardener at Nymphenburg, where he effectually realised his brother's intentions. Preceded by such men, and guided by their example, young Sckell grew up amid the favourable auspices of his future greatness; but he had originally but little inclination for the art of gardening, and on leaving the gymnasium in Munich, wished to continue his studies at the High School, when, in 1811, a variety of circumstances induced him to succeed to this hereditary profession. After a regular apprenticeship he visited the most celebrated gardens in Germany, Holland, and France, and stayed a long time in England in the Botanic Garden at Kew, and at Lee and Kennedy's at Hammersmith. The bounty of his sovereign also enabled him to travel in England and Scotland, with a view of pursuing his studies, and to make himself thoroughly acquainted with the noble and simple style of landscape-gardening practised by Kent and Brown. The death of his father, in 1817, called him suddenly home, where he succeeded to his place as royal gardener at Nymphenburg. He had the good fortune to be under his uncle's directions till 1823, during which time he became more fully conversant with the art, and gave proofs of his acquired knowledge. At that time the gardens at Nymphenburg were very much improved, many new scenes formed, and many tasteful gardens belonging to private individuals were laid out. The hot-house and green-house plants at Nymphenburg which had been collected by his uncle, and also by himself on his journeys, and through the various connexions he had formed, increased so rapidly, that it was found necessary to make a considerable addition to the houses, and which was readily effected by the beneficence of the king.

On the death of his uncle in 1823, the king, Maximilian, appointed him Inspector of the Royal Gardens. In fulfilling this high office he remained faithful to his taste for landscape-gardening, and by making an annual journey to the romantic regions of Bavaria, he there found the best models for gardens, hills, waterfalls, groups of trees, &c.

The chief scene of Sckell's labours of late years has been in Munich; such as the garden belonging to the Ruhmeshalle in the Theresenweise, the Pinakothek, the gardens of several institutions, and of rich private individuals; and in Kissingen, the gardens of the baths there. In the English garden, and also in Nymphenburg, he has formed many beautiful scenes, which give evidence of the pure taste and talents of the deceased. During the seventeen years which he had the management of the Royal Nurseries, they were found to increase in value and extent; and the fruit and vegetable departments were greatly improved, and new sorts introduced. To all those acquainted with the difficulties of the soil and climate of Munich for gardening, it will be evident what share of merit is due to the services of Sckell.

His Majesty the King of Bavaria valued his labours, and rewarded him by raising him to the office of Royal Garden Director in 1833, and with an increase to his salary, and, in 1837, he was elevated to the office of Intendant of all the Royal Gardens in the kingdom of Bavaria. In this honourable situation he lived till his death, which at so early an age called him to another

state of existence. He was a mild and just master, an affectionate husband, and a faithful friend. He is therefore worthy of the tears shed to his memory by those who are left behind. Peace be to his ashes!—*L. C. S. Garten Zeitung*, 1840.

ART. VI. *Provincial Horticultural Societies.*

OUR notices this year, as in that preceding, commence with November 1. 1839, and extend to November 1. 1840; and, as before, we have only given details when we have been enabled to do so through the kindness of the secretaries of societies in sending us newspapers. The total number of societies noticed last year was, — England, 121; Wales, 1; Channel Islands, 2; Scotland, 25; and Ireland, 14. This year the numbers noticed are, — England, 102; Wales, 1; Channel Islands, 2; Scotland, 16; and Ireland, 3; by which it appears that there is a falling off of about one fifth part; but this apparent result is probably owing to the indifference of the local secretaries in sending local newspapers containing accounts of the meetings of the provincial societies to our own and other journals.

ENGLAND.

The Horticultural Society of London. — Abstracts of the proceedings will be found in p. 318.

The West London Gardeners' Association for mutual Instruction. — Abstracts of the proceedings will be found in p. 172. 313. 379. 420, and 611.

The Royal Botanic Society of London. — Notices of the proceedings will be found in p. 321. 514.

BEDFORDSHIRE. — *Biggleswade Horticultural Society.* — April 27. See *Gard. Gaz.*, 1840, p. 328. — July 24. *Ibid.*, p. 511.

Berkshire Royal Horticultural Society. — May 27. See *Ibid.*, 1840, p. 360.

BUCKINGHAMSHIRE. — *Hartwell Gooseberry Show.* — Aug. 10. *Ibid.*, p. 535.

CAMBRIDGESHIRE. — *Horticultural Society.* — Autumn show, 1839. See *Ibid.*, 1839, p. 820. — Spring show, 1840. *Ibid.*, 1840, p. 216.

The Cambridge Horticultural Fête was held July 16., when the following cottagers' prizes were awarded : — best collection of vegetables, Wm. Clarke, Bourne; second best ditto, Ellis Lawson, Bourse; third best ditto, Peter Fuller, Great Abington; fourth best ditto, Thos. Shelford, ditto; fifth best ditto, John Saunders, Bourne; sixth best ditto, James Blows, ditto. The company included all the most influential and fashionable people of the county, and the numbers admitted amounted to upwards of 5500. (*Farm. Journ.*, July 20.)

Cambridge Horticultural Fête. — Sept. 11. See *Gard. Gaz.*, 1840, p. 599.

Cambridge Annual Dahlia Show. *Ibid.*, p. 617.

Cambridge Florists' Society. — Sept. 28. See *Ibid.*, p. 664.

CHESHIRE. — *Chester Floricultural and Horticultural Society.* — April 29. 1840. See *Ibid.*, 1840, p. 311.

Northwich Floricultural and Horticultural Society. — Spring show. See *Ibid.*, 1840, p. 311.

Sandbach Floricultural and Horticultural Society. — May 15. See *Ibid.*, 1840, p. 351.

Stockport Annual Tulip Show. — May 16. See *Ibid.*, 1840, p. 319.

CORNWALL. — *Royal Horticultural Society of Cornwall.* — The first meeting this season was held at Truro on May 15. Among the flowers in the room, there was not anything which, from its rarity or its novelty, would call for particular remark. The following cottagers' prizes were awarded : — Best nosegay geraniums, 2s. 6d., Francis Green, Kenwyn. Best six tulips, 2s. 6d., Joseph Tamblin, St. Mary's. Best nosegay of wallflowers (double), 2s. 6d., John Eudey, Illogan. Best nosegay of stocks (double). 2s., John Bond, Kea. Best nosegay of flowers, 3s., John Eudey, Illogan. Best six apples, of 1839,

5s., Nicholas Scobell, Kea. Best six turnips, 1840, 5s., Henry Lobb, St. Gluvias; second ditto, 2s. 6d., Peter Murton, St. Gluvias. Best three lettuces, 2s. 6d., Peter Murton, St. Gluvias. Best six onions, 5s., 1840, John Gay, Feock; second ditto, ditto, 2s. 6d., Thomas Gay, Feock. Best six leeks, 5s., Thomas Merifield, St. Mary's; second ditto, 2s. 6d., John Eudey, Illogan. Best six carrots, 1840, 2s. 6d., Peter Murton, St. Gluvias. Best dish of spinach, 2s. 6d., Walter Lance, St. Mary's. Best two cabbages, 5s., Richard Pearce, Illogan; second ditto, 2s. 6d., Samuel Martin, Mylor. Best twelve potatoes, of the growth of 1840, 7s. 6d., John Eudey, Illogan. Best basket of vegetables, of sorts, 7s. 6d., John Eudey, Illogan; second ditto, 5s., Peter Murton, St. Gluvias.

Extras. Rhubarb, 2s. 6d., Henry Lobb, St. Gluvias; spinach, 2s. 6d., Henry Lobb, St. Gluvias; eschalots, 2s. 6d., George Marks, Kenwyn; apples, 2s. 6d., James Trevena, St. Gluvias; gooseberries (of one sort), 2s. 6d., John Luxton, Kenwyn; heartsease, 2s. 6d., James Luxton, Kenwyn. (*West Briton*, May 27.)

The second exhibition of this Society was held on July 17., at Falmouth. The show of plants and flowers was a very good, though by no means a large, one; and the attendance was tolerably numerous, and highly respectable. The vegetables and fruits shown by the cottagers were especially worthy of notice and of commendation; for, without possessing the means which wealth will always command, to adopt every kind of valuable suggestion that the advancement of science may afford, the cottagers' productions were barely excelled by their more wealthy competitors. This state of things is most satisfactory on more grounds than one, and it is with great pleasure that we again record a fact which is not now asserted for the first time. (*Ibid.*, July 24.)

The third and last meeting of the season was held on September 15. at Truro, and, in spite of the stormy state of the weather, there was a very numerous and fashionable attendance of visitors from all parts of the county. The appearance of the room was unusually gay, although the supply of plants was not so large as is frequently seen. The pillars, and underneath the gallery, were tastily festooned, and there were two very beautiful devices exhibited, which presented a *coup d'œil* that was highly gratifying. The first was a very large and elegant device, formed of dahlias by Mr. Treseder, the present occupant of the gardens formerly belonging to Lewis Daubuz, Esq. This was behind the president's chair, and in the centre of the room. The design embraced, *inter alia*, the words "Victoria Rex;" but although we cannot praise Mr. Treseder's Latin, which perhaps he does not wish to have praised, we may justly say he deserves great credit for his beautiful and varied display of this elegant flower. At the bottom of the room stood the other device, formed of different flowers, and consisting of the initials "V. R. A." These were surmounted with a crown. This device was exhibited by George Nicolls Simmons, Esq., and obtained for that gentleman the silver medal, — another stimulus in addition to the many he has already received for his successful cultivation of botanical science. The orchidaceous plants, though small as to the supply, were select. There was a new species, named *Maxillaria Skinneri*, by Mr. Bateman, in compliment to its discoverer, G. Ure Skinner, Esq., of Guatemala, a gentleman to whom the botanical collections of this country are under great obligations, for the liberality with which he has contributed some of the finest productions of the interesting spot on which he resides. This plant was grown by Sir C. Lemon, and is the first that has flowered in this country. The show of fruit was highly gratifying, and, without particularising, we may say that the melons, pines, strawberries, cherries, currants, and grapes (a second crop from the garden of S. Moyle, Esq.), apples, pears, &c. &c., were worthy of all praise. The cottagers' exhibition was very beautiful; really far superior to anything that we have ever had of the kind. There were not many flowers shown, the articles exhibited being chiefly of the more useful kind. (*Ibid.*, Sept. 18.)

Trecan Cottage-Gardening Society. — The sixth annual exhibition of this

excellent and truly benevolent Society was held at Trecau Gate, on the 16th July. The day, with the exception of a partial shower or two, was, on the whole, fine; and the numerous assemblage (among which we noticed some of the first families in the neighbourhood) appeared highly gratified with their visit to this rural scene. More than the usual taste was displayed in the erection of booths, &c. We have attended the meetings of this Society year after year, from its infant state, when it sprang up under the auspices of the Rev. Richard Buller, to the present time; and to the cottagers we would say that, considering the dry spring and summer, we never saw a better display, on their table, of fruits, vegetables, and flowers. (*West Briton*, July 24.)

CUMBERLAND.—*The Whitehaven Floral and Horticultural Society*.—The first exhibition of this Society for the present season took place on April 30. During the afternoon the rooms were crowded by our gayest fashionables, and by well-dressed people, who all seemed highly delighted with the objects presented to their notice. The exhibition, indeed, was decidedly the best first show of the season which has yet distinguished the annals of this Society. The competitors were numerous, and the specimens of the various flowers of a very superior order. The leading objects of attraction were the auriculas, and the assortments of these beautiful gems of the garden which were brought forward by Mr. Gaitskell and Mr. Robert Elliot were certainly never surpassed, if ever equalled, in the same room. (*Whitehaven Herald*, May 2.)

The summer show took place on July 16th. This exhibition consisted of flowers, fruits, and vegetables, of each of which there was a tolerably fair display, though it was far from being so well attended as we have seen it on former occasions. (*Cumberland Packet*, July 21.)

The autumn show of flowers, fruits, &c., belonging to the members of this Society was held on September 24., and there was much reason to congratulate the friends of the exhibition on the triumphant success which distinguished their exertions. In many respects the show was much superior to any which has taken place in the Savings' Bank Assembly Room. The dahlias were, of course, the crowning gems of the occasion, and of these upwards of 1100 were in the room; and it was truly wonderful, considering the wet and turbulent weather which we have experienced of late, that they should have been brought for exhibition in such exquisite bloom, and altogether in so rich a state of perfection. The day being fine, the attendance of visitors was both numerous and fashionable, and the exhibition received the tribute of praise both from connoisseurs and the less learned admirers of the beauties of Flora and the products of the garden. (*Whitehaven Herald*, September 26.)

DERBYSHIRE.—*Chesterfield Gooseberry Show*.—May 3. See *Gard. Gaz.* p. 535.

Derby Annual Gooseberry Show.—July 27. See *Ibid.*, p. 584.

DEVONSHIRE.—*The Royal Devon and Cornwall Botanical and Horticultural Society*.—The spring exhibition of this Society displayed some of Flora's choicest stores, and was of the most splendid description, exceeding in many respects most of the vernal shows hitherto witnessed. The plants and flowers in the large room were arranged in the most tasteful manner, presenting to the eye the varied riches and unrivalled brilliancy in which nature decks her choicest gems at this season. The rare and beautiful exotics, interspersed with the stove and green-house plants, offered on every side subjects for admiration, and called forth the strongest feelings of delight. We cannot omit noticing the superior manner in which the cottagers produced the articles they exhibited. The potatoes belonging to John Chapman of Saltash, were equal to any in the amateur's class. His basket of vegetables was laid out with very great taste. John Courtis, of Ford Cottage, Stoke, produced a most splendid dish of peas, equal to any we saw. The wallflowers shown by J. T. Addicott were exceedingly beautiful; but it would be invidious to particularise further, where so much industry was displayed. We only regret that the Society's benevolent intentions are not more appreciated by the agricultural labourers in our district. (*Plymouth Herald*.)

The second exhibition for the season took place at Devonport, on July 23. when the show of plants, flowers, and fruit greatly surpassed that of any previous exhibition in this town. The company, also, was numerous and highly respectable. Mr. William Rendle, Union Road, Plymouth, as usual, contributed largely to the display of flowers on the occasion. His collection of fuchsias was particularly noticed, and was very fine; amongst them were specimens of *Standishii* and *Devonia*, two excellent new varieties. (*Devonport Independent*, July 25.)

The twenty-ninth exhibition of the above Society took place at Plymouth, Sept. 10., and was numerous and fashionably attended. More than usual exertions had evidently been made to render the occasion splendid; and we must give the Committee of Management great credit for their admirable arrangements. To attempt a full description of the plants and flowers in this exhibition would be useless; suffice it that, for its brilliant and diversified character, the scene was never equalled by any previous one of the kind in this neighbourhood. The fruit tables "groaned" under the weight of their delicious burden; as a whole, we never saw this branch of the exhibition surpassed in the West of England. Of the vegetable productions, all of which were excellent, there was the great curiosity of a pumpkin, grown by Mr. Samuel Ellis of Fleet, from a seed taken out of the wreck of the Royal George; it weighed, we should think, about 10 lb., and was an object of general remark, from the peculiarity of its origin. The cottagers' productions were more than usually fine, and the following is a list of premiums awarded: — Apples, the best dish of sorts, 5s., J. T. Addicott, Millbrook; second best ditto, 4s., John Courtis, Ford Park, Stoke. Pears, the best dish of, 4s., W. Fiddick; second best ditto, 3s., J. T. Addicott. Plums, best dish of six, 3s. 6d., J. T. Addicott; second best ditto, 2s. 6d., John Keast, St. Stephens; third best ditto, 4s. 6d., J. Dingle, St. Stephens. China Asters, the best collection of, 5s., J. Chapman, Saltash; second best ditto, 4s., Thomas Dennis, Saltash; third best ditto, 3s., J. Dingle. Hollyhocks, best collection of, 3s. 6d., Thomas Dennis; second best ditto, 2s. 6d., J. T., Addicott. Roses, best bouquet of, 3s. 6d., J. Smith, Plymstock; second best ditto, 2s. 6d., J. T. Addicott. Hardy annuals, best collection of named, 4s., John Chapman; second best ditto, 3s., Thomas Dennis; third best ditto, 2s., J. Davies. Stocks, the best bouquet of, 3s. 6d., J. Chapman; second best ditto, 2s. 6d., John Davies. Marigolds, French and African, best collection of, 2s. 6d., J. Chapman. Vegetables, best basket of sorts, 10s., John Smith; second best ditto, 7s., Thomas Dennis; third best ditto, 5s., J. Chapman; fourth best ditto, 3s. 6d., J. Davies. Peas, the best dish of, 4s., J. Chapman; second best ditto, 3s., John Dingle. Scarlet runners, best dish of, 4s., John Davies. Dwarf kidneybeans, best dish of, 3s., John Smith. Onions, the best dish of, 4s. 6d., John Chapman; second best ditto, 3s., John Dingle. Potatoes, the best sample of, 4s., John Keast, St. Stephens. Sweet herbs, the best collection of named, 2s. 6d., J. Davies.

Prizes for Personal Merit. *First division:* 1st prize, to the cottager or labourer with small weekly wages, who has reared the largest family in habits of industry, without parochial assistance, 1l. 10s., W. Hancock, St. Stephens; 2d prize, ditto, the second largest family, &c., 1l., John Keast, St. Stephens; 3d prize, ditto, the third largest family, &c., 10s., W. Fiddick, Millbrook. *Second division:* 1st prize, to the cottager or labourer, with small weekly wages, who cultivates his garden in a superior manner, the interior of whose cottage displays the greatest neatness and economy, and whose children are educated in habits of industry and sobriety, 1l., John Keast; 2d prize, ditto, in the second best manner, &c., 15s., Thomas Hearle, Knackersknowle; 3d prize, ditto, in the third best manner, &c., 15s., Mr. Smith, Plymouth. *Third division:* 1st prize, to the servant in the rural district, who has remained the largest number of years in the service of the same master or mistress, and whose conduct has been exemplary, 1l., W. Hancock; 2d prize, ditto, the

second largest, &c., 10s., W. Fiddick ; 3d prize, ditto, the third largest, &c., 10s., Nicholas Pinwell, Yealm Bridge. (*Ibid.*, Sept. 12.)

Exeter Horticultural Society. — Spring show. See *Gard. Gaz.*, 1840, p. 345.

Exeter Grand Dahlia Exhibition. — See *Ibid.*, 1840, p. 632.

DURHAM. — *Sunderland Floral and Horticultural Society.* — Spring show. See *Ibid.*, 1840, p. 319. — Aug. 18. See *Ibid.*, p. 551.

The Gateshead Ancient Florists' Society recently held their third annual show for ranunculuses, at the house of Mr. James Scott, Half Moon Inn, Bridge Street, Gateshead, when the prizes were awarded to the following gentlemen : — Mr. John Wilson, first, with De Drain ; third, with Orestes ; fourth, with Grand Monarque, and fifth with Rebecca ; Mr. Andrew Bouglas, second, with Suprema. (*Gateshead Observer*, July 11.)

ESSEX. — *South Essex Horticultural Society.* — Spring show. See *Gard. Gaz.*, 1840, p. 440.

GLOUCESTERSHIRE. — *Cheltenham Horticultural and Floral Societies.* — April 21. 1840. See *Ibid.*, 1840, p. 268. — May 19. See *Ibid.*, p. 328. — June 2. See *Ibid.*, p. 360. — Aug. 7. See *Ibid.*, p. 551.

Cirencester Horticultural Association. — July 3. See *Ibid.*, 1840, p. 458.

Cirencester Horticultural Society. — Aug. 7. See *Ibid.*, 1840, p. 521.

Pittville Horticultural Association. — April 28. 1840. See *Ibid.*, 1840, p. 281.

HAMPSHIRE. — *Andover Horticultural Society.* — June 18. (*Salisbury Herald*, June 20.) — Sept. 25. See *Gard. Gaz.*, p. 663.

Hampshire Horticultural Society. — The first exhibition of this Society for the present season took place at the Corn Exchange, Winchester, March 12., and to the lovers of botanical pursuits must have afforded a treat of no ordinary kind : the flowers introduced were of great rarity and beauty, and the show of fruits and vegetables were every way worthy the advances which the science of horticulture has made within the last few years. This meeting has been looked forward to by the members of the Society with more than usual interest, from its having been known that a presentation of plate of great value was intended to be made to their excellent secretary, Dr. Wickham, at the Society's dinner after the business of the day. Mr. Burt of Southampton introduced a new and pleasing variety of ornamental ironwork for floricultural purposes, which was much admired. (*Hampshire Advertiser*, March 14.)

The second meeting of the Hampshire Horticultural Society was held at the Archery Rooms, Winchester, May 21., to which numerous visitors were attracted for the purpose of viewing the exhibition of flowers and fruits, which was very superior. (*Hampshire Chronicle*, May 25.)

At the third meeting of this Society at the New Corn Exchange, Winchester, June 23., there was a very good show of fruit, flowers, and vegetables, from the gardens of the neighbouring gentry. (*Salisbury Herald*, June 27.)

Winchester Auricula Show. — April 30. 1840. See *Gard. Gaz.*, 1840, p. 281.

Winchester Pansy Show. — June 2. See *Ibid.*, p. 410.

HERTFORDSHIRE. — *Herts Horticultural Society.* — The first annual show of this useful and flourishing Society took place in the Shire Hall, Hertford, April 30. The display of flowers was as splendid as we ever remember to have witnessed at any previous spring show ; and the company was more numerous and fashionable than usual. The specimen plants were particularly fine, consisting of azaleas, euphorbias, and hoveas, of great luxuriance. The miscellaneous collections of Mr. Warner and Mr. Harrison were arranged with the accustomed taste, and presented a splendid appearance. The cottage exhibitors were but few, but the quality of the vegetables and flowers exhibited was good. (*Herts Reformer*, May 2.)

The second or summer show of this Society, held on June 25., was distinguished for its grand display of fruit and flowers, and drew together a

numerous assemblage of the families of the county. The collections of roses were unusually fine and splendid; those from C. S. Chauncy, Esq., were particularly admired; and from the same gardens was exhibited a very fine seedling variety of the Bourbon rose. The fuchsias from the gardens of W. R. Baker, Esq., of Bayfordbury, were the finest ever exhibited, standing 7 or 8 feet high, and being profusely covered with bloom. The grapes and peaches from Earl Cowper's, and the pines from Viscount Melbourne's, were the most prominent among the fruits. We were much gratified at witnessing the growing spirit of emulation among the cottagers; their productions being of a superior kind, and more numerous than we have seen at any previous exhibition. (*Herts Reformer*, June 27.)

The Autumn Show. — *Sept. 9.* See *Gard. Gaz.*, 1840, p. 599.

HUNTINGDONSHIRE. — *Huntingdonshire Horticultural Society.* — *April 28.* 1840. See *Ibid.*, 1840, p. 296. — *July 28.* See *Ibid.*, p. 520.

St. Neot's Horticultural Society. — *May 5.* See *Ibid.*, 1840, p. 327. — *Aug. 4.* See *Ibid.*, p. 552.

KENT. — *Kent and Canterbury Floral and Horticultural Society.* — On April 2., the first exhibition this year of this Society took place at the Corn Exchange in this city. The day was altogether inviting, and a very goodly company was attracted. The plants belonging to Mr. Alderman Masters were, as usual, splendid and numerous, alike extraordinary for their beauty as for their rarity. (*Canterbury Journal*, April 4.)

On April 30., the second exhibition for this season of the above Society took place at the Corn Exchange. The show fully displayed what the genial weather of the last two months has effected in the garden. There was a brilliant array of choice and beautiful flowers; and the company was very respectable and numerous. Many of the plants even surpassed those hitherto exhibited. The two grand attractions were, Mr. Masters's *Rhododéndron arbóreum*, and the Rev. H. Hilton's *Œe plicátilis*. Our attention was arrested, on first entering the room, by the grandest specimen that we ever beheld at any flower show, in town or country. It proved a variety of the Nepal rhododendron, that had been hybridised by the species most commonly cultivated, the *pónticum*. To describe it would be impossible, it must be seen to form any idea of its grandeur and beauty. Let, however, the reader imagine the common rhododendron grown into a tree of 10 ft. in height, and 18 ft. in circumference, rising with a single stem for about 3 ft., and then gradually giving out branches so as to form a symmetrical head; but instead of the blossoms, as in the garden kind, being of a pale lilac colour, they should be of a bright crimson, elegantly mottled with deep brown spots, and nearly every branch to be terminated with a bold cluster of flowers; and then some idea, though faint it be, may be formed of this superb variety. We counted more than 170 heads of blossoms, and we believe there were more lurking beneath "its ample pavilion of green." (*Ibid.*, May 2.)

On Sept. 10th, the last exhibition this season took place at the Corn Exchange. The show was attended by most of the respectable families of the city and neighbourhood. There was a better collection of succulents than on any previous occasion. Mr. Shepherd's and Mr. Masters's were particularly fine and attractive, as also were Mr. Friend's *larocheas* and *Sempervivum variegátum*. (*Ibid.*, Sept. 12.)

Dover Horticultural Society. — *June 18.* See *Gard. Gaz.*, 1840, p. 409.

Eltham Horticultural and Floricultural Society. — *July 21.* See *Ibid.*, 1840, p. 479.

Maidstone Horticultural Society. — *May 20.* See *Ibid.*, 1840, p. 345.

West Kent Pink Society. — *July 2.* See *Ibid.*, 1840, p. 440.

Wingham Horticultural and Floricultural Society. — *July 30.* See *Ibid.*, 1840, p. 505. — *Sept. 15.* *Ibid.*, p. 616.

LANCASHIRE. — *Barrowford Pink Show.* — *July 9.* See *Ibid.*, 1840, p. 458.

Warrington Tulip and Horticultural Show. — *Spring show.* See *Ibid.*, 1840, p. 458. — *Dahlia show.* See *Ibid.*, p. 664.

Whitefield Pansy Show.—Sept. 5. See *Gard. Gaz.*, 1840, p. 616.

LEICESTERSHIRE.—*Leicestershire Floricultural and Horticultural Society.*—Spring show. See *Ibid.*, 1840, p. 399.—June 1. See *Ibid.*, p. 458.—Aug. 7. See *Ibid.*, p. 521.

Hinckley Horticultural and Floricultural Society.—Sept. 25. See *Ibid.*, 1840, p. 663.

Melbourne Floricultural and Horticultural Society.—Sept. 22. See *Ibid.*, 1840, p. 615.

Melbourne Gooseberry Show.—Aug. 3. See *Ibid.*, 1840, p. 584.

LINCOLNSHIRE.—*Grantham Floral and Horticultural Society.*—Aug. 8. and Sept. 26. See *Ibid.*, 1839, p. 773.

Grantham Carnation Show.—Aug. 6. See *Ibid.*, 1840, p. 584.

Horncastle Floricultural and Horticultural Society.—June 30. See *Ibid.*, 1840, p. 458.

Stamford Floricultural and Horticultural Society.—April 29. See *Ibid.*, 1840, p. 327.—Summer show. See *Ibid.*, p. 458.—Aug. 12. See *Ibid.*, p. 527.

MIDDLESEX.—*Hampstead Florists' Society.*—June 16. See *Ibid.*, 1840, p. 409.—Sept. 22. See *Ibid.*, p. 655.

Metropolitan Society of Florists.—Oct. 13.

Middleton Gooseberry Show.—Aug. 8. See *Ibid.*, 1840, p. 584.

Middleton Tulip Show.—See *Ibid.*, 1840, p. 458.

South London Horticultural Society.—June 16. See *Ibid.*, 1840, p. 394.—July 28. *Ibid.*, p. 489.—Sept. 15. *Ibid.*, p. 598.

South Walworth Amateur Floricultural Society.—Sept. 21. See *Ibid.*, 1840, p. 615.

West London Amateur Dahlia Society.—Sept. 14. See *Ibid.*, 1840, p. 615.

NORFOLK.—*Lynn Horticultural Society.*—May 13. See *Ibid.*, 1840, p. 351.—July 29. *Ibid.*, 521.

Norfolk and Norwich Horticultural Society.—May 27. See *Ibid.*, 1840, p. 351.—Dahlia show. *Ibid.*, p. 598.

Norwich Dahlia Show.—See *Ibid.*, 1840, p. 615.

NORTHUMBERLAND.—*Felton Floricultural Society.*—May 5. 1840. See *Ibid.*, p. 311.

Felton Florists' Society.—Tulip show. See *Ibid.*, 1840, p. 399.—June 29. *Ibid.*, p. 425.—Pink show. *Ibid.*, p. 489.—Aug. 24. *Ibid.*, p. 569.

Hexham Floricultural and Horticultural Society.—Sept. 16. See *Ibid.*, p. 633.

Newcastle Botanical and Horticultural Society.—A general meeting of this Society was held in the Music Hall, Nelson Street, March 7. (*Newcastle Courant*, March 12.)

The second meeting of this Society took place, Aug. 28. (*Ibid.*, Sept. 4.)

NOTTINGHAMSHIRE.—*Beeston and Chilwell Flower Show.*—Spring show. See *Gard. Gaz.*, 1840, p. 361.—Aug. 4. *Ibid.*, p. 521.

Nottingham Floricultural and Horticultural Society.—Spring show. See *Ibid.*, 1840, p. 344.

Old Lenton Gooseberry Show.—See *Ibid.*, 1840, p. 522.

Retford and Bawtry Horticultural Society.—Spring show. See *Ibid.*, 1840, p. 311.

OXFORDSHIRE.—*Oxfordshire Horticultural Society.*—April 30. 1840. See *Ibid.*, p. 297.—July 1. *Ibid.*, p. 473.—July 28. *Ibid.*, p. 507.

SHROPSHIRE.—*Market Drayton Horticultural and Floricultural Society.*—May 7. See *Ibid.*, 1840, p. 312.

Salop Floricultural and Horticultural Society.—Summer show. See *Ibid.*, p. 583.

SOMERSETSHIRE.—*Bath Royal Horticultural and Botanical Society.*—The first exhibition for the season took place on April 14, at the Society's Gardens in Victoria Park, of which it may be desirable to give a brief description. In so doing, we cannot but express our admiration at the consummate ability which has been displayed in their arrangement. The north side of the Botanical Garden is laid out in a large oval shape, and contains an illustration of

the Linnæan system, by means of ornamental plants. Although few of the plants are yet in flower, the appearance of this portion of the garden is, even at present, highly picturesque. Students and connoisseurs in botany will here find ample means for gratifying their *penchant*: while their labours will be considerably lessened by the assistance which has been provided for them, the class and order of each plant being indicated, as well as its generic, specific, and popular English name. To the south is the medical department of the garden, and here are to be found specimens of all the hardy plants now enumerated in the pharmacopœia. The eastern half of the lawn is laid out in illustration of the Jussieuan or natural system of botany. We observe with pleasure the progress which has been made by the Society in its collections of *Iris*, *Narcissus*, *Cratægus*, peony, &c., several handsome donations of these fine plants having been made. A number of rhododendrons, growing in the open air, are also looking remarkably well; and not the least attractive portion of the gardens is its excellent collection of aquatic plants. The rocky structure which surrounds the fountain has been planted with a variety of sedum or stone crop, which is now rising, and will shortly present a very interesting appearance. We may here mention that it is in contemplation to remove the hedge which encloses the half-acre recently added to the grounds, and to substitute for it one which shall be more characteristic of a botanic garden. Brief and imperfect as this description necessarily is, we trust it may prove sufficient to stimulate curiosity in behalf of these gardens, and that it will demonstrate the activity and good taste which have been displayed by the committee to whom their formation was intrusted. We must now turn to the show.

We should be liable to imputation were we to say that a more splendid and gratifying exhibition never took place in this or any other city. It may, however, be asserted with the strictest truth, that, with extent and variety, it was in every way worthy of the distinguished reputation hitherto maintained by this Society. The weather, notwithstanding the lowering aspect of the morning, proved propitious; and at the hour appointed for the admission of the subscribers and the public the gardens were thronged by a numerous and fashionable company. The enthusiasm manifested on the occasion will be made apparent by the fact, that not less than four thousand persons visited the show during the day. We may also add that the arrangements which had been made for the accommodation of the spectators had been so well contrived, that, notwithstanding the continual ingress and egress which lasted during the whole day, no confusion occurred, nor was the presence of so large a concourse felt to be inconvenient or oppressive in the least degree. The influence of the sun was less potent than on some of the preceding days; while refreshing breezes from the west rendered the temperature delightfully agreeable. The fine gravel walk which encircles the gardens afforded a pleasant promenade for the company; the splendour and beauty of the surrounding landscapes adding to the other attractions which it presents. A royal standard (the gift of a number of ladies) floated gaily from a lofty pole, and considerably enhanced the animated appearance of the scene. Mr. Reynolds's celebrated band was in attendance; and played a succession of the most popular pieces in their usual talented manner. One of the most decided improvements made by the committee is the establishment of a ladies' cloak and attiring room; a convenience which has long been a desideratum at shows of this kind. (*Bath Gazette*, April 18.)

Bath Horticultural Society, Sidney Gardens.—May 28. See *Gard. Gaz.*, 1840, p. 360.—June 3. See *Ibid.*, p. 439.—July 22. *Ibid.*, p. 479.

Bristol and Clifton Dahlia Show.—See *Ibid.*, p. 616.

STAFFORDSHIRE.—*Burton-upon-Trent Horticultural Society.*—April 22, 1840. See *Ibid.*, p. 268.—May 20. See *Ibid.*, p. 440.

Stafford Floricultural and Horticultural Society.—Spring show. See *Ibid.*, 1840, p. 344.

Ottoveter Horticultural and Floricultural Society.—Aug. 7. See *Gard. Gaz.*, 1840, p. 551.

Wolverhampton Horticultural Society.—Summer show. See *Ibid.*, p. 534.

Wolverhampton Tulip Show.—May 20. See *Ibid.*, p. 344.

SUFFOLK.—*Ipswich Floricultural Society.*—April 30. See *Ibid.*, p. 296.

Stowmarket Horticultural Show.—Sept. 17, 1839. See *Ibid.*, 1839, p. 709.

SURREY.—*Croydon Dahlia Show.* See *Ibid.* 1839, p. 616.

East Surrey Florists' Society.—June 25. See *Ibid.*, 1840, p. 425.

Wallington Pink Show.—June 30. See *Ibid.*, 1840, p. 441.

WARWICKSHIRE.—*Birmingham Gooseberry and Flower Show.*—Aug. 3. See *Ibid.*, 1840, p. 507.

The Birmingham Grand Dahlia Exhibition, opened Sept. 30, at the Town Hall, and was continued during the following day. Notwithstanding the late period of the season, and the injury sustained in some plantations from the frost on the night of the 19th ult., there was a very splendid collection of flowers, the blooms on many of the stands being remarkably fine in form and perfect in colour. The general opinion appeared to be that the exhibition surpassed that of 1839; and there is no doubt that increased attention has, during the present season, been paid to the cultivation of this beautiful and admired flower. (*Midland Counties Herald*, Oct. 1.)

Coventry Horticultural Society.—June 1. See *Gard. Gaz.*, 1840, p. 441.

WILTSHIRE.—*Wilts Horticultural Society.*—The first exhibition for the present season took place at the Council Chamber, Salisbury, April 4. The assemblage of visitors was unusually large, and the display of plants was such as to convince us that increased life has been imparted to the Society since the last season. The forced shrubs were of first-rate excellence, and we have never seen at any previous exhibition so numerous an assortment of specimens of this gay and attractive tribe. (*Salisbury Herald*, April 11.)

July 21. The third exhibition for this season took place at the Council Chamber, Salisbury, but owing to the unfavourable state of the weather, the attendance of visitors was unusually thin. The collection of plants, however, was remarkably good; and we never recollect to have witnessed, at the July meeting, such an abundance of splendid specimens. The orchideous plants were particularly attractive, and the geraniums, notwithstanding the lateness of the season, were in fine bloom. (*Ibid.*, July 25.)

Sept. 8. The fourth exhibition for the season of the Wilts Horticultural Society was held in the Council Chamber, Salisbury. (*Hampshire Chronicle*, Sept. 14.)

WORCESTERSHIRE.—*Worcestershire Horticultural Society.*—Spring show. See *Gard. Gaz.*, 1840, p. 311.—July 28. See *Ibid.*, p. 506.

Vale of Evesham Horticultural and Floricultural Society.—April 29. and May 15. See *Ibid.*, 1840, p. 344.—July 24. *Ibid.*, p. 506.

YORKSHIRE.—*Doncaster Horticultural Society.*—May 13. See *Ibid.*, p. 328.—Summer show. See *Ibid.*, p. 473.—Aug. 4. *Ibid.*, p. 551.

Heath Tulip Show.—May 18. See *Ibid.*, p. 345.

Kingston Floricultural and Horticultural Society.—Oct. 1. See *Ibid.*, p. 663.

The Horticultural Society for Sheffield and its Vicinity held their third exhibition for this season at the Botanical Gardens, June 29, 1840. (*Sheffield Mercury*, July 4.)

Sheffield Class Dahlia Show.—Sept. 14. See *Gard. Gaz.*, 1840, p. 615.

Sheffield Pink Show.—July 6. See *Ibid.*, p. 489.

Sheffield Tulip Show.—May 21. See *Ibid.*, p. 345.

Wakefield Floral Society.—Auriclea show. April 27, 1840. See *Ibid.*, p. 281.—Aug. 10. *Ibid.*, p. 521.

Wakefield Tulip Show.—May 25. See *Ibid.*, p. 345.

York Amateur Florists' Society.—May 13. See *Ibid.*, p. 344.—June 17. *Ibid.*, p. 440.—Aug. 10. *Ibid.*, p. 527.

York Horticultural Society.—Autumn show. See *Ibid.*, p. 569.

York Horticultural Exhibition.—Sept. 22. See *Ibid.*, p. 631.

WALES.

DENBIGHSHIRE. — *Wrexham Horticultural Society*. — June 5. See *Gard. Gaz.*, p. 425. — Sept. 29. *Ibid.*, p. 664.

CHANNEL ISLANDS.

JERSEY. — *The Agricultural and Horticultural Society*. — On July 15., the summer exhibition of fruits, vegetables, and flowers took place at the New Cattle Market, Minden Place, Jersey. At no former exhibition had we ever been so much gratified. At 2 o'clock, the hour appointed for the introduction of visitors, the press for admission was very great, and on our entrance we were much pleased to find the area literally crowded with the rank and fashion of the island. Shrubs were placed in various parts of the ground, and the fruits and flowers under the piazzas were well arranged; the beauty of the latter was much admired. The object which attracted most attention was a beautiful stand of plants belonging to Mr. Bernard Saunders, seedsman, florist, &c., of Halkett Place. The plants grouped in the open space were also furnished by Mr. Saunders, to whose assistance the Society was on this as on all former occasions greatly indebted. An excellent stand was also exhibited by Mr. Edward Turgis, nurseryman; nor must we omit to mention several fine bouquets of flowers displayed in various parts of the market: one by Mrs. Daniel Janvrin attracted much attention, and was universally admired; it formed the front part of St. Matthew's Chapel, Millbrook, and must have cost the fair architect much labour and ingenuity: a horse at full speed (Mr. Godfray's), and a little Cupid with his bows and arrows (Mr. Kaye's), formed entirely of flowers, were also universally admired. (*Jersey British Press*, July 17.)

GUERNSEY. — *Guernsey Horticultural Society*. — May 20. The flowers exhibited were on the whole exceedingly good. The geraniums, of which there was a large number, were generally of a superior quality and in good condition. Mr. I. S. Carré's, to which a first prize was awarded, were, we should say, almost perfect, and evinced good taste in selection, and much skill and care in cultivation: to carry the palm, on a first attempt, against five or six of the best and most experienced amateurs in the island, must have been highly gratifying to him, and we believe that the award of the judges was confirmed by every connoisseur present, although their task can have been by no means an easy one. Mr. Cockburn's pears and apples, Mr. Joshua Priaulx's potatoes, and Mr. Augustus Dobrée's asparagus, were, perhaps, the best of the members' productions, if we except half a dozen remarkably fine apples (*Pomme Suzon*), exhibited by Mr. James Hammond of Jersey. The fruits and vegetables exhibited by the cottagers were, as is almost invariably the case, superior to those belonging to the members. Among these may be mentioned, six very fine oranges, exhibited by N. Brouard, three of which were growing on one stem; half a pound of strawberries, exhibited by Margaret Giffard; Mrs. Machon's and John Falla's apples; James Langlois's green peas and cabbages; S. Luff's potatoes, artichokes, and cabbages; J. Falla's asparagus; T. Sebire's potatoes, lettuces, and carrots; and John Moullin's rhubarb. As respects flowers, the best were H. H. Le Pelley's sparaxis, which were decidedly good, and the bouquets belonging to Judith Le Page and Rachel Robert. This exhibition afforded a strong evidence of the marked improvement which has taken place in Guernsey, in the departments of floriculture and horticulture, since the formation of the Society. Not only have articles of a superior description become more generally cultivated than they were formerly, but their style of growth has much improved; and among no class of persons has this improvement been more marked than among the cottagers, whose productions are highly creditable to the island. (*Star*, May 23.)

SCOTLAND.

The Caledonian Horticultural Society held their spring meeting on March 5.,

and a full account of what passed on that occasion will be found from p. 270 to 272. The other meetings of the Society held in the course of the year were equal in point of interest to the first, and displayed a great many garden productions, both useful and ornamental.

ABERDEENSHIRE. — *Aberdeenshire Horticultural Society*. — Spring show. See *Gard. Gaz.*, 1840, p. 319.

The summer exhibition of this invaluable institution was held in Aberdeen on June 23., and presented decidedly the best display which has ever been exhibited at this season of the year. In the vegetable department there were some remarkable specimens of the kidney potato, full-sized and ripe though raised in the open air. The cabbages (Yorks) presented a great improvement over those of last year, being much more solid and free from huskiness than they used to be ; the early turnips were also very superior. It is especially pleasing to notice these improvements, because the poorer classes of the community have so much dependence on the vegetable market. In the display of fruit, the strawberries were much admired ; the cherries, too, were good ; and there were a few green-fleshed melons of very superior quality. Three bunches of grapes, by Mr. Runcie of Millbank, were the best we ever saw so early in the season. A new seedling ranunculus, by Mr. Wright, the clerk, was the leading attraction in the floral department. He has named it the "British Queen," and well does it deserve the distinction, for it is a stately plant, and promises to be very prolific. There were a good many fuchsias, and a very rich and rare variety of green-house plants, especially of geraniums. The border flowers were also good, and the designs most tastefully, and, we may say, ingeniously, wrought out. Nor must we forget Mrs. Rae's home-made wine, for which she very justly obtained a premium. We may notice, in passing, that this department has strong claims on the tee-totallers, for, if we may credit the best-informed of our wine-brewers, an article can be made which "will cheer, but not inebriate." (*Aberdeen Herald*, June 27.)

For the autumn show of this Society, see *Gard Gaz.*, p. 623.

CLACKMANNANSHIRE. — *Clackmannanshire Horticultural Society*. — The first meeting of this Society for the season was held at Alloa, the 14th of May. The room was adorned, as usual, by evergreens and flowers, part of which surrounded two fine paintings by our townsman, Mr. Bell. The meeting was not numerously attended ; but this may have arisen from the season being unusually far advanced, and a supposition that all the auriculas, primroses, polyanthuses, and other spring flowers were past and gone. This was, no doubt, the case to a considerable degree, on account of the long continued dry weather, and owing to this exhibition having been put off a week later than last spring, at a time when such weather was not anticipated. Notwithstanding all this, the articles both for competition and exhibition were numerous and in good order. The following were exhibited : — From Airthrey Castle, *Rhododéndron arbóreum*, *R. álbum*, pelargoniums, pansies, &c. &c. ; from Kennet, *Wistària Consequàna*, *Hóya carnòsa*, *Cístus*, &c. ; from Powis, herbaceous plants, pansies, apples, cabbages, spinach, turnips, &c. ; by Mr. Livingstone, Alloa, a variety of pansies ; and by Mr. Williamson, Alloa, a variety of plants. (*Stirling Journal*, May 29.)

The second exhibition of this Society for the season was held at Alloa, on July the 9th, when the room was adorned with a variety of fine shrubs and evergreens, kindly furnished from Alloa Park, by the Countess of Mar and Kellie. The visitors were numerous, for, amidst much rainy weather, the day was dry and favourable. Both the quantity and quality of vegetables, flowers, and fruits much exceeded the expectations of the directors, being abundant as well as excellent. On this occasion eight prizes were allotted for cottagers, that is, persons who work their own gardens, only three of which were competed for. It is much to be wished that cottagers may be induced to become contributors to these exhibitions ; much good might result from their occasional success, as it would probably stimulate them to cultivate their gardens with more attention and in a better manner than at present. (*Ibid.*, July 17.)

The Kilmadock and Kincardine in Monteith Cottage and Farm Garden Society held its first meeting for this season in Kincardine school-house, on the 11th July, when the following prizes were awarded:— Best three Dutch roses, sorts: 1st, John M'Kinlay, Deanston; 2d, James Stewart, Thornhill; 3d, Archibald M'Nie, Ochertyre. Best China rose in pot: 1st, Archibald M'Nie; 2d, William Gilchrist, Deanston. Best six violas, two flowers of each: 1st, John M'Kinlay, Deanston; 2d, William Gilchrist; 3d, John Ferguson, Clarkton. Best geranium in pot: 1st, John M'Kinlay; 2d, William Gilchrist; 3d, William M'Farlane, Blairdrummond. Best bouquet hardy flowers: James Simpson, Doune. Best three sorts of daisies, six of each: 1st, William Gilchrist; 2d, Archibald M'Nie; 3d, William M'Farlane, Blairdrummond. Best three calceolarias, of sorts: 1st, John M'Kinlay; 2d, William Gilchrist; 3d, William Caw, Doune. Best three sorts mimulus, small bunch of each: 1st, John Taylor, Auchinlyach; 2d, Archibald M'Nie. Six heaviest early potatoes: 1st, James Stewart Thornhill; 2d, George Bryce, Doune; 3d, James Livingstone, Kirklane. Best kept six late potatoes, crop 1839: 1st, George Stalker, Summerlane; 2d, William M'Farlane; 3d, William Gilchrist. Best three yellow turnips: 1st, Andrew Reid, Summerlane; 2d, William Caw; 3d, William Bayne, Doune. Best twelve pods green pease: 1st, William Robertson, Woodlane; 2d, Peter Stewart, Thornhill; 3d, Isaac Fixton, Thornhill. Best brace early cabbages: 1st, Isaac Fixton; 2d, William M'Farlane; 3d, Peter Dow, Blairdummond. Heaviest six spring-sown onions (entire): 1st, Peter Stewart; 2d, Isaac Fixton; 3d, William Robertson. Heaviest six potato onions (entire): 1st, Thomas Welch, Thornhill; 2d, James Stewart; 3d, William Gilchrist. Heaviest four stalks rhubarb: 1st, John Taylor; 2d, William Gilchrist; 3d, John M'Kinlay. Heaviest twelve gooseberries: 1st, Isaac Fixton; 2d, John Taylor; 3d, John Ferguson. The house was tastefully decorated with evergreens from Blairdrummond and the neighbouring gardens. From Blairdrummond, Deanston, Newton, and Argaty were exhibited collections of fruits, flowers, and vegetables. From Mr. Reid, teacher, Kincardine, two large cauliflowers; from Miss M'Gowan, splendid turnips; from Mr. Jamieson, surgeon, ripe morello cherries; from William Bayne, strawberries; from R. C. Marshall, Esq., *Fuchsia globosa*. The articles brought forward, both for exhibition and competition, were superior to any articles produced at any former competition, and did great credit to all parties. The numerous and highly respectable visitors, who patronised the exhibition with their presence, expressed themselves highly delighted with the increasing taste and success in the cultivation of the several articles. (*Stirling Journal*, July 17.)

DUMFRIESSHIRE.— *The Dumfries and Galloway Horticultural Society* held its anniversary meeting on the 10th September, in Dumfries. We have seen a larger display of fruit; but the muster was wonderful, the season considered; and, if deficiency appeared at all as to quantity, it was otherwise as to quality. Numerous parties of ladies and gentlemen visited the show-room in the course of the day, and appeared highly satisfied with the appearance of everything, including a splendid specimen of the *Campánula pyramidalis*, and several highly beautiful floral decorations. (*Dumfries Courier*, Sept. 15.)

FIFESHIRE.— *Fife Horticultural and Floricultural Society.*— The first meeting for the season took place in the Town Hall on the 6th May, and was honoured with the presence of most of the distinguished families of the city. We never saw a finer display of plants at any corresponding meeting than this; the whole reflected great credit on the growers, and on their employers, in enabling them to produce so many valuable plants. (*Fife Herald*, May 14.)

The Kennoway Floricultural and Horticultural Exhibition was held in the parochial school-room on the 29th of June, when premiums were awarded by the judges for tulips, ranunculuses, roses, calceolarias, geraniums, irises, pansies, double catchfly, herbaceous flowers, peas, turnips, early potatoes, cabbages, cauliflowers, and lettuces, according to their merit. Several sweepstakes were also decided. Amongst the ornamentals, the geraniums held the

first place, and the ranunculuses, pansies, and herbaceous flowers were likewise good, whilst few professional gardeners could have produced better potatoes, peas, or cabbages. There was, however, a paucity of competitors, and fewer articles were brought forward for competition than we have seen for some seasons past. Besides the articles competed for, there were exhibited, a large and tastefully built bouquet from Kingsdale; a good collection of flowers from Newton Hall; bouquet roses and pansies from Durievale; turnips and onions from Charlton; pansies and sweet williams from Balfour; turnips from Cameron Distillery; a quantity of perfectly ripe black currants, raised by G. Arthur, Balcurvie; with some fine geraniums, and a plant of *Fuchsia fulgens*, from a member of the Society. (*Fife Herald*, July 9. 1840.)

The *Pitlessie Horticultural Exhibition* took place June 28., when the judges awarded numerous prizes. There was exhibited a large assortment of very splendid dahlias and hollyhocks from Priory; dahlias from Edenwood; dahlias, seedling hollyhocks, seedling heartsease, and peculiarly fine geraniums, from Ramornie. (*Ibid.*, October 1.)

The *St. Andrews Horticultural and Floricultural Society's* meeting took place in the Town Hall on the 24th June. The show of flowers and vegetables was most excellent, and reflected great credit on the exhibitors. The geraniums, Cape heaths, and bouquets were splendid productions. We are happy to state that the Society's exhibitions not only keep pace with the science, but are far in advance of societies in more favoured localities. (*Ibid.*, July 2.)

FORFARSHIRE. — *Brechin Horticultural Society.* — July 9. See *Gard. Gaz.*, 1840, p. 474.

Dundee Floricultural and Horticultural Society. — May 13. See *Ibid.*, 1840, p. 327. — June 10. See *Ibid.*, p. 394. — July 22. See *Ibid.*, p. 506. — August 26. See *Ibid.*, p. 584.

MORAYSHIRE and NAIRN. — *Forres and Nairn Horticultural Society.* — June 18. The first exhibition for the season of this Society took place in Forres. On this occasion, the flowers produced, both for competition and exhibition, far exceeded any former display in point of number, variety, and splendour; and it is only due to the members of the Society, to state that neither exertion nor expense was spared to render this exhibition not only conducive to the promotion of scientific horticulture, but also of general and exciting interest to the public.

An air-tight plant case, or portable conservatory, for growing plants without fresh supplies of water or air, on the principle recommended by Mr. N. B. Ward of London, was exhibited by the secretary, Mr. Gillan; the same having been without air or water for the space of four months, the plants notwithstanding exhibited great luxuriance.

The rapidly increasing taste for the science of horticulture, fostered and patronised as it now so powerfully is by the Royal Caledonian Horticultural Society, cannot fail to prove the source of much intellectual recreation to its lovers, and even to the general admirer. The great superiority of this exhibition over those of former years attests the growing spirit of emulation and attention among the members of the Society, and its beneficial influence is daily becoming more apparent. With a limited district for its operation, this Society had many difficulties, at its outset, to contend with, which have happily been overcome, and now stands forth a pleasing example of what may be done by union and perseverance. (*Forres Gazette*, July 1.)

PERTHSHIRE. — *Royal Perthshire Horticultural Society.* — The spring show of this Society was held May 4. The exhibition was very good, considering the season, both as regards the merits of the articles and their variety. The general effect was, however, weakened by the absence of the usual splendid bouquets, but the company, which comprehended most of the neighbouring county families, testified their usual interest in the exhibition. Besides the articles competing we observed the following:— Scone: a large and most beautiful plant of *Clianthus puniceus*, and *Euphorbia splendens*. Kinfauns: *Ardisia elegans* and *Blétia Tankervilleæ*. Moncreiffe: a basket of very

choice cut flowers. Delvine: a seedling *Fuchsia*, named *F. delvinensis*. As usual, Miss Henderson seems to delight the admirers of flowers, by her beautiful productions in wax, in imitation of which we observed the following represented:—*Bigonia venusta*, *Camellia* var., *Cosmèlia rubra*, *Erica vestita*, *Hibiscus violaceus*, *Kennèdya Marryàttæ*, *K. rubicunda*, and *Nelumbium speciosum*. Pitfour: a beautiful variety of *Camellia japonica*, *Cactus* seedling, *Corræa speciosa*, and twelve varieties of good apples in excellent preservation. Fingask: *Brugmansia sanguinea*, with its long trumpet-like flowers. Methven Castle: mushrooms of uncommon size, showing superior cultivation. From Mr. Ross, teacher, Collace, a splendid assortment of pansies. (*Perthshire Courier*, May 7.)

The summer exhibition of this Society was held July 9. Considering the unfavourable character of the season latterly, the show was on the whole good, although not so rich in various departments as we have seen. The exhibition was well attended by county and city families. (*Ibid.*, July 16.)

RENFREWSHIRE.—*West Renfrewshire Horticultural Exhibition.*—May 1. The members of the West Renfrewshire Horticultural Society held their first competition for the season. The vegetables shown were excellent, the flowers very beautiful, and the green-house and hot-house plants, many of which were in flower, were rare and of first-rate quality. The admirable way in which every thing was arranged reflected the highest credit on all concerned. Although sometimes there were several hundreds of people present at once, there was no confusion, and the visitors were enabled, without difficulty, to inspect minutely every article shown. The room in which the exhibition was held is 200 ft. in length and 60 ft. in breadth, and two rows of tables, extending nearly the whole length of the apartment, were stocked with green-house, stove, and hardy plants, chiefly from gardens in this vicinity; facts which at once demonstrate the splendour of the exhibition itself, and, when the early period of the season is taken into account, the abundant materials which Greenock possesses for displays of this kind. It is gratifying to know that the zeal and talent of our practical gardeners are such, that the judges admitted occasionally the difficulty of deciding where all were so good. We were struck with the beauty and interest of many plants exhibited from various gardens, not for competition: such as a very fine specimen of the *Clíanthus puniceus*, richly in flower, and about 10 ft. high, from John Scott, Esq.; together with some fine pelargoniums, also in bloom; and the beautiful *Epiphýllum speciosum*, grown pendent, and covered with its delicate flowers. There were also, from the garden of John Gray, Esq., President of the Society, specimens of many highly curious succulents, a great variety of Cape heaths and choice New Holland plants, with several from Madagascar, besides the coffee, the green and black tea, the cinnamon, also a well-grown specimen of the *Dionæa muscipula*, or fly-trap, in flower, with the Norfolk Island pine, the *Pinus longifolia*. In a group from Provost Fairrie were specimens of *Kennèdya glabra* and *Hòvea Cèlsi* in fine bloom. (*Greenock Advertiser*, May 5.)

ROXBURGHSHIRE.—*Kelso Horticultural Society.*—Summer show. See *Gard. Gaz.*, 1840, p. 410.

STIRLINGSHIRE.—*Falkirk Horticultural Society.*—July 11. The second meeting of this Society for the current year was held at Falkirk. Upon that occasion, the flowers and fruit brought forward for competition were of the most select kind, evincing a judgment and taste well worthy the encouragement of the patrons of this excellent institution. Besides these, a number of beautiful and rare plants were brought for exhibition. The variety and richness of the green-house seemed collected into a short focus, which charmed the numerous visitors to this botanical treat. (*Stirling Journal*, July 17.)

The annual general meeting and last exhibition of the Falkirk Horticultural Society for the season, took place in the large hall of the Red Lion Inn, Falkirk, at which the display of flowers, fruits, and vegetables was superior to any brought forward at any former autumnal meeting of this flourishing Society. The day having been most favourable, numerous visiting parties

arrived in carriages, and during the hours of exhibition the hall was crowded by members and visitors. (*Stirling Journal*, Sept. 25.)

The *Stirling Horticultural Society* held its summer show on July 15., and, in addition to the articles for competition, there were exhibited select lots of herbaceous and green-house plants from Meiklewood, Kepp, Viewfield Lodge, Blairdrummond, Deanston House, Craigforth, Mrs. Alexander's of Allan Park, Sir John Hay, Bart., and Drummond's Nursery. Cucumbers from Comely Bank, and early potatoes from Mr. Robert M'Naughton, King Street; and from Deanston House a handsome plant of the Siberian cow parsnip in full flower (a new agricultural plant), measuring 9 ft. high, with luxuriant foliage, raised from seed sown in May, 1839. This specimen is now exhibiting in Drummond's Agricultural Museum. There were also exhibited thirteen numbers of Maund's *Botanic Garden*, presented to the Society by the author. This very appropriate gift seemed to excite considerable interest, and the author has the warmest thanks and best wishes of the Society. The day being favourable, the exhibition was numerous and respectably attended. The show produced some very superior specimens in the various classes named for competition, and the decision of the judges seemed to give general satisfaction. (*Ibid.*, July 17.)

IRELAND.

Royal Horticultural Society of Ireland. — April 28. 1840. See *Gard. Gaz.*, 1840, p. 297. — June 25. See *Ibid.*, p. 440.

BELFAST. — *Fête Champêtre in the Belfast Botanic Garden.* — Aug. 27. See *Ibid.*, p. 550.

The Northern Horticultural Society. — Sept. 13. 1839. See *Ibid.*, 1839, p. 819. — April 26. 1840. See *Ibid.*, 1840, p. 281.

The autumn show of this most useful institution was held Sept. 18., in the Exchange Buildings (the free use of which, for the occasion, having been handsomely presented to the Society, by Messrs. Scott, Brothers). The collection of stove and green-house plants was not so large as we have seen on former occasions; although there were exhibited several valuable specimens, well grown, and in good flower. There was an excellent display of dahlias, sufficient to compensate for any deficiency in other articles. There were several very tasteful bouquets exhibited. Two, in particular, were peculiarly worthy of notice: one from Mr. Andrews of Ardoyne, which combined taste in its arrangement, and valuable flowers in its composition; the apex displayed sentiment, in addition to fancy, the loyal fingers of the composer having poetically converted some of the finest flowers of the parterre into the significant symbols of Irish loyalty, "V. R." being beautifully arranged as a cupola to a splendid pyramid of Flora's choicest gems. Ardoyne has long been celebrated for its specimens of Irish art; in this instance, loyalty and art have combined their attractive qualities. There was also a most tasteful bouquet from a cottage gardener, named Darragh; it was most creditable to the imagination of the framer, and equally so to the grower. Several seedling dahlias were displayed. (*Northern Whig*, Sept. 19.)

KILKENNY. — *Kilkenny Horticultural Society.* — The spring exhibition of this Society was held in the Museum, April 29. (*Kilkenny Moderator*, May 2.)

END OF THE SIXTEENTH VOLUME.







SMITHSONIAN INSTITUTION LIBRARIES



3 9088 01527 8534