

UNIVERSITY OF TORONTO

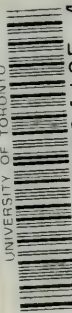

3 1761 00984135 4



Digitized by the Internet Archive
in 2008 with funding from
Microsoft Corporation

A.R. McLeod

Oct 25th 1915

Cains College
Cambridge

X RAYS AND CRYSTAL STRUCTURE

LONDON : G. BELL AND SONS, LTD.,
PORTUGAL ST., LINCOLN'S INN, W.C.
NEW YORK: THE MACMILLAN CO.
BOMBAY: A. H. WHEELER & CO.



Presented to the
LIBRARY of the
UNIVERSITY OF TORONTO
by
Mr. J. R. McLeod

X RAYS AND CRYSTAL STRUCTURE

BY

W. H. BRAGG, M.A., D.Sc., F.R.S.

CAVENDISH PROFESSOR OF PHYSICS, UNIVERSITY OF LEEDS

AND

W. L. BRAGG, B.A.

FELLOW OF TRINITY COLLEGE, CAMBRIDGE



LONDON
G. BELL AND SONS, LTD.

1915

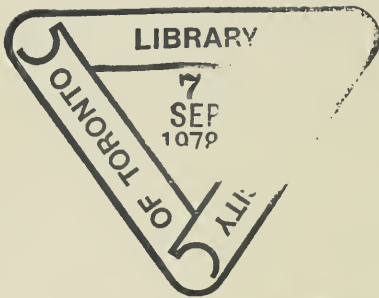

QD
945
B7

PREFACE.

It is now two years since Dr. Laue conceived the idea of employing a crystal as a 'space diffraction grating' for X-rays. The successful realisation of the idea by Messrs. Friedrich and Knipping has opened up a wide field of research in which results of great interest and importance have already been obtained. On the one hand the analysis of X-rays which has been rendered possible has led to remarkable conclusions concerning the atoms which emit them under the proper stimulus, and has thrown an entirely fresh light on problems of atomic structure. On the other hand the architecture of crystals has been laid open to examination; crystallography is no longer obliged to build only on the external forms of crystals, but on the much firmer basis of an exact knowledge of the arrangement of the atoms within. It seems possible also that the thermal movements of the atoms in the crystal will be susceptible not only of observation but even of exact measurement.

In order to grasp the meaning and progress of the new science, it is necessary to have some knowledge both of X-ray phenomena and of crystal-

lography. As these branches of science have never been linked together before, it is to be expected that many who are interested in the new development find themselves hampered by a tantalising ignorance of one or other of the essential contributory subjects. In this little book my son and I have first made an attempt to set out the chief facts and principles relating to X-rays and to crystals, so far as they are of importance to the main subject. We have devoted the remaining and larger portion of the book to a brief history of the progress of the work, and an account of the most important of the results which have been obtained.

The book is necessarily an introduction rather than a treatise. The subject is too new and too unformed to justify a more comprehensive treatment. We have tried to draw its main outlines for the use of those who wish to understand its general bearings, and we hope that our statement may even be of some service to those who wish to make its acquaintance practically and to share in the fascinating research work which it offers. No doubt the latter will consult also the original papers.

Considering the purpose which we have had in view we have refrained from the discussion of a number of interesting points of contact with other sciences and with older work, such as for example the remarkable investigations of Pope and Barlow. We have not even given a complete account of all the experimental investigations that have been made in connection with the subject itself, and have been

content with the merest allusion to the serious mathematical discussions which it has received at several hands.

The publication of the book has been delayed by the difficulties of these times, which have also hindered the continuance of some researches and the publication of others that are almost or quite complete. A few results which could not be included in the book itself are given in supplementary notes at the end.

The same circumstances have left me to write this preface alone. Probably, however, I should have demanded the privilege in any case. I am anxious to make one point clear, viz., that my son is responsible for the 'reflection' idea which has made it possible to advance, as well as for much the greater portion of the work of unravelling crystal structure to which the advance has led.

W. H. BRAGG.

January, 1915.

CONTENTS.

CHAPTER	PAGE
I. INTRODUCTORY - - - - -	1
II. DIFFRACTION OF WAVES - - - - -	8
III. THE X-RAY SPECTROMETER - - - - -	22
IV. THE PROPERTIES OF X-RAYS - - - - -	38
V. CRYSTAL STRUCTURE - - - - -	50
VI. X-RAY SPECTRA - - - - -	66
VII. THE ANALYSIS OF CRYSTAL STRUCTURE. I. -	88
VIII. THE ANALYSIS OF CRYSTAL STRUCTURE. II. -	112
IX. THE RELATION BETWEEN CRYSTAL SYMMETRY AND THE ARRANGEMENT OF THE ATOMS -	142
X. THE ANALYSIS OF CRYSTALS. III. - - -	160
XI. THE INTENSITY OF X-RAY REFLECTION - -	175
XII. THE ANALYSIS OF THE LAUE PHOTOGRAPHS -	207
SUPPLEMENTARY NOTES - - - - -	227
INDEX - - - - -	229

CHAPTER I.

INTRODUCTORY.

EVER since the discovery by Rontgen of the rays which bear his name, their nature has been the subject of the keenest investigation. In many respects the rays resemble light. They move in straight lines and cast sharp shadows, they traverse space without any obvious transference or intervention of matter, they act on a photographic plate, excite certain materials to phosphorescence, and can bring about the ionisation of a gas. In other respects the rays have seemed to differ from light. The mirrors, prisms and lenses which deflect light have no such action on X-rays; our diffraction gratings do not diffract them; neither double refraction, nor polarisation is produced by the action of crystals. If the velocity of X-rays could have been shown without question to have been the same as that of light, it would have been a most important piece of evidence. E. Marx of Leipzig devoted the greatest skill and perseverance to the attempt to measure the velocity, and claimed that he had overcome all the many acute objections brought against his work. His results led him to assert the equality

of the velocities of the two kinds of rays ; but the difficulties of the experiment were so great that his work did not bring universal conviction.

Undoubtedly the strongest evidence—up to the present time—of the similarity of nature of light and X-rays was supplied by the discovery of a form of polarisation of the latter rays. Barkla showed that the X-rays issuing from a bulb and impinging upon matter were less scattered by the matter in a direction parallel to the stream of cathode rays in the bulb than in directions at right angles to the stream. A pencil of rays selected from the scattered radiation, though more difficult to work with than primary rays, showed the same effect to a much higher degree.

These facts were in accordance with the theory of the electromagnetic origin of X-rays due to Schuster, Wiechert, Stokes, J. J. Thomson, and others. Cathode particles, whose flight had been suddenly arrested by impact on the anticathode, should send out ether pulses, that is to say, a sort of light in which the vibrations would tend to be parallel to the direction of the cathode-ray stream. Such vibrations, impinging on matter and scattered thereby, would give rise to less radiation in the direction of the vibrations than in any other.

The strongest evidence *against* the similarity of nature of light and X-rays has arisen from considerations of the transference of energy by means of the latter. Cathode rays impinge on the anticathode and give rise to X-rays: it is found that

these in turn give rise to cathode rays, *i.e.* swiftly moving electrons, when they encounter matter of any kind. It is very remarkable that the speed of the secondary electron which the X-ray produces is nearly the same as that of the primary electron which produces the X-ray. This is so, no matter what the intensity of the X-rays may be, nor how far from the bulb the production of the secondary X-ray takes place, nor what the nature of the matter from which the secondary electron seems to spring.

It seems almost imperative that we should consider the X-ray to have transferred so much energy from the one electron to the other, and this involves the conception of a 'quantum' of energy radiation travelling through space without alteration of form or content as it goes. The idea is quite foreign to orthodox conceptions of the transference of radiation energy. No one has been able to suggest how it is to be reconciled with the older hypotheses.

It has, however, become increasingly clear that the phenomenon which appears so irreconcilable with light theory must in some way be made to fit in. The 'photo-electric action' is found, on closer investigation, to be of exactly the same kind as the X-ray action which has just been described. It is quite clear that we cannot explain our difficulties over the X-ray energy question by asserting that X-rays and light are not to be compared with each other because they are of different natures.

Just when we are pondering on the difficulties of

reconciling facts which appear to be in conflict, a new discovery is made of extraordinary interest. It tells us in the first place that the right path has been chosen in assuming light and X-rays to be identical in nature. Indeed, it shows that the identity is even closer than we had thought in that it precludes us from ascribing differences in character to anything else than mere differences in wave-length. While all the new knowledge the discovery gives is of course to be regarded as so much new and welcome guidance to a solution, the limitation of differences to variety of wave-length seems to be a fresh difficulty in the way, but a very interesting one.

In the second place, we have a new and powerful method of analysing a stream of X-radiation. We are placed in the same position with regard to X-rays as we may conceive ourselves to have been in the case of light if we had, up to a certain time, been able to analyse light only by observing the absorbing powers of various screens, and had then been presented with a spectrometer. Again, we have a new means of investigating the structure of crystals.

Instead of guessing the internal arrangement of the atoms from the outward form assumed by the crystal, we find ourselves able to measure the actual distances from atom to atom and to draw a diagram as if we were making a plan of a building. In doing so, we seem certain to acquire, indeed we have already acquired, knowledge of great importance to

chemical theory, to the theory of specific heats, and so on.

This list of new powers is far from exhaustive, but it will serve to show the importance of the new discovery. The fundamental idea of the advance is due to Dr. Laue, a member of the staff of the University of Zurich.

A large proportion of our knowledge of the phenomena of light is derived from investigations suggested by the undulatory theory. Our most useful instrument is the spectrometer, and especially that form of it which makes use of the diffraction grating. The essential feature of the use of the grating is the absolute measurement of wave-length which it renders possible. The grating consists, as is well known, of an arrangement of parallel and equidistant straight lines ruled in great numbers on a glass or metal surface. The spacing of the lines must in practice be of the same order as the wave-length to be measured. Sodium light, which has a wave-length of .0000589 cm., is diffracted through about 24° by a grating which has 7000 lines to the centimetre, *i.e.* a spacing of .000143 cm.

On various grounds it has been known for some time that the length of the X-ray wave, if there is such a thing, should be about 10^{-8} cm. or 10^{-9} cm., *i.e.* about ten thousand times smaller than the waves of sodium light. To construct a grating of appropriate spacings is unthinkable, because the spacings would need to be of the order of the distances between the molecules of a solid.

Laue conceived the idea of using the ordered arrangements of atoms or molecules of a crystal as a proper 'grating' for the investigation of X-rays. The spacings of the atoms or molecules are of the right order of magnitude. The diffraction problem is not so simple as in the case of the grating, because the regularity of arrangement of the atoms of the crystal extends over three dimensions instead of one. Laue was, nevertheless, successful in his attack upon the mathematical side of the problem. He showed that if a pencil of X-rays was made to traverse a crystal, diffracted pencils would be formed, arranged about the primary beam in a regular pattern according to laws which he formulated. A photographic plate placed perpendicular to the primary rays and behind the crystal would show a strong central spot where the primary rays struck it, and other spots arranged in regular fashion round the central spot in the places struck by the diffracted pencils. The experiment was carried out by Messrs. Friedrich and Knipping in the spring of 1912, and was a brilliant success from the first. Since then the authors have pursued their investigations vigorously, and their diagrams have attained the most admirable clearness. Examples are given in Plate I. The beautiful geometrical arrangement of the pattern is in reality a manifestation of the regularity of crystal structure.

We shall not discuss now the mathematical investigation of the theory of the space-grating. Experience has shown that there is an exceedingly simple

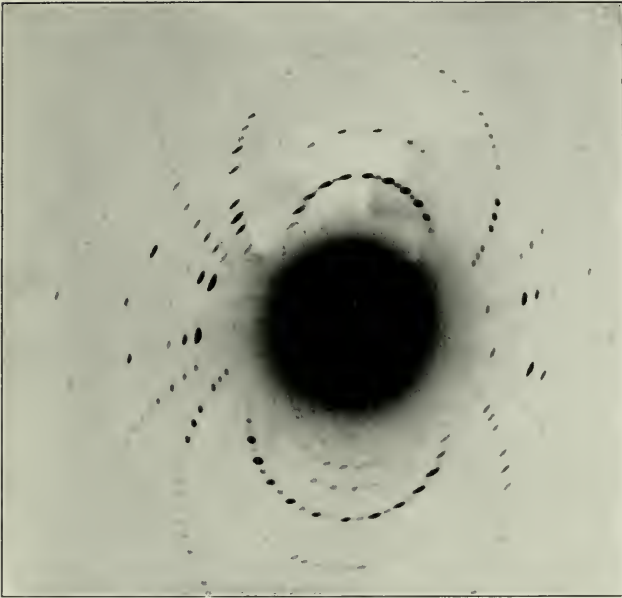

NICKEL SULPHATE.

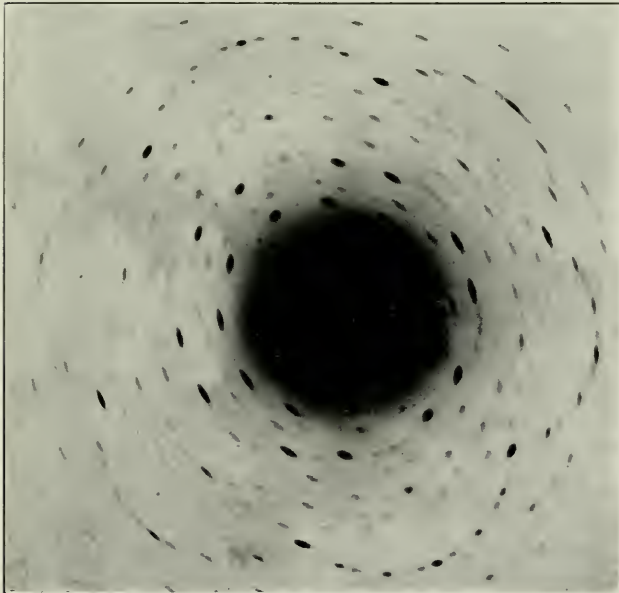

BERYL.

method of attacking the question which differs in form, though of necessity not in essence, from the original method of Laue. The newer method leads also to a simple and useful mode of experimental procedure. It will be convenient to follow it for the present.

CHAPTER II.

DIFFRACTION OF WAVES.

THE appearance of the photographs obtained by Laue suggests at once the action of interference. Generally, when X-rays fall on a body which scatters them, the scattering takes place in a continuous manner all round the body. In this case, however, the scattering takes place in certain directions only, and the scattered rays are grouped into separate pencils which leave their impression on the photographic plate in a series of isolated spots as shown in Plate I. The arrangement of these spots shows, both by its regularity and by the form which the regularity takes, that the effect is intimately connected with the crystal structure. It must be connected, moreover, with the fundamental pattern of the structure, and not with any accidental consequences of the crystal growth. For example, in one case the pattern is regular and two-fold, and the crystal—nickel sulphate—has two-fold symmetry in a plane perpendicular to the direction in which the X-rays passed through the crystal. In the other case the pattern is six-fold: these are the characteristics of the symmetry of beryl in the corresponding plane. It is natural to

suppose that the Laue pattern owes its origin to the interference of waves diffracted at a number of centres which are closely connected with the atoms or molecules of which the crystal is built, and are therefore arranged according to the same plan. The crystal is, in fact, acting as a diffraction grating.

In this chapter an attempt will be made to solve the problem of the diffraction of waves by such a grating. It is clear that this problem is very much more complicated than that of the diffraction of waves by the ordinary line grating, such as is used in spectroscopy. The latter owes its power of analysing a complex beam of light into its component wave-trains to the system of parallel lines which are ruled upon its surface at exactly equal intervals, many thousands going to the inch. When a train of waves falls on the system, each line acts as a fresh centre from which a 'diffracted' train of waves spreads out, and it is the interaction of the similar wave trains from all the lines which gives rise to the diffraction effects. This kind of grating is the simplest kind possible, for we have a single series of lines repeated one after the other in a row. It may be called a 'one dimensional' or 'row' grating. A crystal, on account of its regular structure, also forms a grating, but a much more complicated one. A molecule, or a small group of molecules, forms the unit of the crystal pattern, and this unit is repeated throughout the whole volume. A convenient analogy in two dimensions—the crystal has three dimensions—is to be found in the pattern of a wall paper. The

wall paper has regularity in two directions of space, and the unit of its pattern is one member of what may be called a doubly infinite series. The crystal is one degree more complicated still, for the units are repeated in three dimensions.

In order then to analyse Laue's results, we must solve the problem of diffraction by a three-dimensional grating. The light waves of very short wave length fall on the grating, and from each element, consisting of the little unit of pattern as described above, an identical train of waves is diffracted. We have to solve the problem of the interference of these diffracted trains.

At first sight it would appear that this is a problem demanding very complicated analysis, and indeed if attempted directly this is so.

In his original paper* on the newly discovered effect, Laue treated the problem in the direct manner. He obtained a mathematical expression which gave the intensity at all points due to the diffraction of waves of known wave length incident on a set of particles arranged on a space lattice. A study of this expression showed that the spots on his photographs were in positions agreeing with the supposition that they were due to diffraction, and so proved the all-important nature of the new discovery. The expression is, however, unwieldy to handle in the investigation which we are about to describe. Any analysis concerned with three-dimensional geometry

* *Sitzungsberichte der Königlich Bayerischen Akademie der Wissenschaften*, June, 1912.

must be of the most simple type if its results are to be visualised, and we shall find it very useful to be able to form a mental picture of the mechanism of the effect which we are considering. Fortunately there exists a device by which the analysis can be made quite simple, and of which we will make use in what follows.

Let us suppose that we have a series of particles which all lie in one plane, these particles representing atoms or whatever the little obstacles are which scatter the waves. When a pulse passes over these atoms, each emits a diffracted pulse which spreads

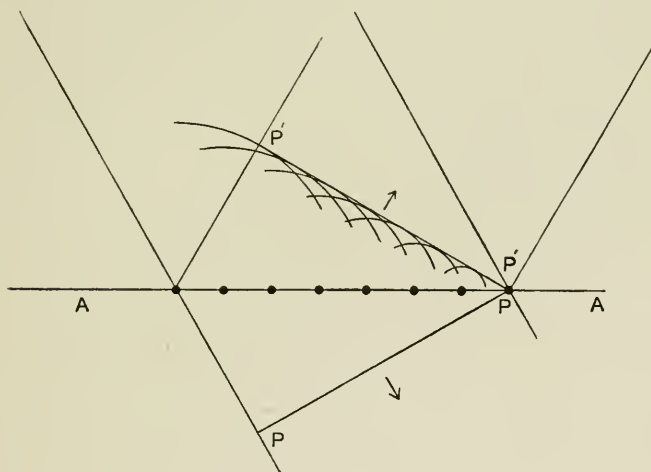

FIG. 1.

spherically all round it. In Fig. 1 we see the result of the passage of the pulse PP over the atoms in the plane AA . The circles represent the pulses sent out by atoms in the plane. It is obvious that

all the diffracted wavelets touch a 'reflected wave front $P'P'$ ', in fact we have only repeated Huygens' construction for the wave front reflected from a plane surface. It does not matter how the particles are arranged on the plane AA , as long as they lie exactly on that plane.

Thus we see that when the pulse passes over a set of particles which lie in a plane, the diffracted pulses all combine to form a wave front which obeys the laws of reflection from the plane.

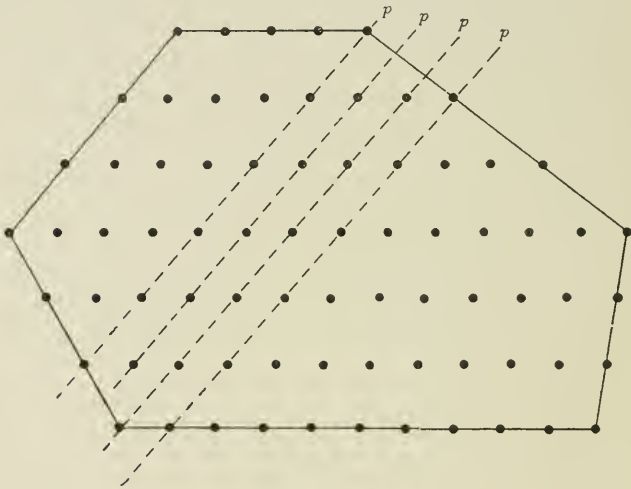

FIG. 2.

Turning now to the crystal, it is evident that its particles possess this arrangement in planes. Fig. 2 represents a crystal, everything being drawn in two dimensions as in the last figure. It is the natural arrangement of the particles in planes which gives rise to the plane faces of crystals, just as the

form of the crystal in Fig. 2 is a polygon bounded by straight lines. The analysis which we have just made shows that if a wave passes over the crystal, all the particles in one plane combine to reflect it. Therefore, if we choose any one way of arranging the crystal particles in planes, corresponding to the lines pp in Fig. 2, and then find the direction in which a wave would be reflected by these parallel planes, this direction will be one in which to look for an interference maximum. There are many ways of choosing such planes, but in only a few cases are the planes thickly studded with particles; the more 'complex' the planes the more thinly are they studded. It is, on the whole, to the 'simple' planes that the faces of the crystal are parallel, just as the sides of the polygon in Fig. 2 are parallel to the more obvious rows of the structure. Therefore one might say, to sum up, that when a pulse passes over the crystal its scattered energy is concentrated into definite beams, and that these beams may be regarded as feeble reflections of the pulse on the possible faces in the interior of the crystal.

The reflection does not depend upon the existence of any polished surface on the outside of the crystal, it depends upon an arrangement of planes within. It is this difference between what is here called the 'reflection' and the true reflection of ordinary light on surfaces which may make the analogy somewhat puzzling. When we talk of the X-rays being reflected by the crystal, it must be borne in mind that the term is only used in order to simplify the

conception of the effect. There can be no such thing as a surface reflection of X-rays. The surface reflection of light is an effect concerned with the skin of the reflecting body alone. As long as the reflecting film is more than a few wave lengths thick the full reflection is obtained. But when X-rays fall on a crystal face, the first few layers of atoms cannot diffract an appreciable proportion of the rays, for experiment shows that the rays must pass through some millions of layers before the X-ray beam is appreciably absorbed. Reflection takes place on all the layers, the only limitation being that if a layer is too deep within the body of the crystal, the absorption by the superincumbent layers reduces its contribution to an amount that is negligible. To the comparatively long waves of light the atom structure is so fine grained that the medium is practically continuous. The X-rays are so short, on the other hand, that a crystal is to them a series of widely separated and regularly arranged particles, each of which diffracts a very small proportion of their energy.

If the waves may be regarded as reflected in the crystal planes, this idea should be capable of explaining the Laue photographs. When Laue employed zinblende to obtain his first photographs, the exact arrangement of the atoms in the crystal was unknown. However the mere fact that it belonged to the cubic system was enough to determine the arrangement of the 'simple' planes with respect to the incident X-ray pencil. When the test was

made* it was found that the spots on the Laue photographs were situated as if the incident beam had been reflected simultaneously by all these planes. Each spot corresponded to some simple way of choosing the planes, showing that this way of regarding the problem was sound. Nevertheless the photographs obtained by Laue, while they were the origin of the new subject, are among the more complicated of the phenomena concerned with X-rays and crystals. They are treated fully in a later chapter.

Let us suppose that we have a crystal with a large natural face on it, one of its important faces. From what has been said of the crystal structure in connection with Fig. 2, it is clear that this implies possible arrangement of the particles in a series of planes parallel to this face. Therefore, as a pulse falls on this face, it will appear to be reflected from the face itself, though we know really that it is not at the face, but inside the crystal that reflection is occurring. Yet, since the rays do not usually penetrate more than a millimetre in depth into the crystal, and often much less than a millimetre, it is only a thin layer parallel to the face which is engaged in the reflection. In future we shall, for brevity, describe a reflection of this kind as reflection by the face.

So far we have considered the reflection of a single pulse. We may now proceed to consider the reflection of a regular train of waves. Each plane reflects

* W. L. Bragg, *Proc. Camb. Phil. Soc.* vol. xvii. part 1, p. 43.

the wave train as a wave train, but when the reflected trains are in the same phase, that is to say, are so arranged that they fit on to each other exactly, crest to crest, and hollow to hollow, the reflected energy is far greater than if this condition is imperfectly fulfilled, even if the want of fit is exceedingly small.

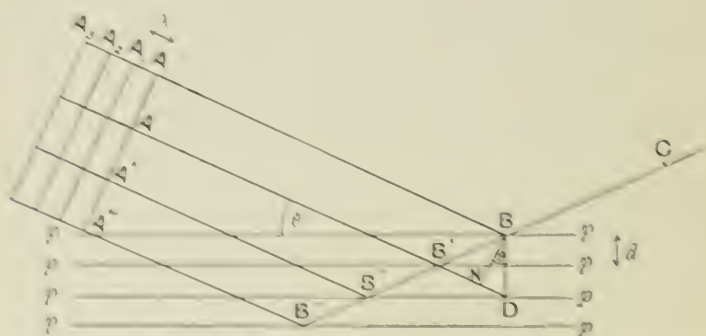

FIG. 3.

Let the crystal structure be represented in Fig. 3 by the series of planes, $\hat{p}, \hat{p}, \hat{p}, \hat{p}$ being their common distance apart or 'spacing.' A, A_1, A_2, A_3, \dots are a train of advancing waves of wave length λ . Consider those waves which, after reflection, join in moving along BC , and compare the distances which they must travel from some line such as AA' before they reach the point C . The routes by which they travel are $ABC, A'B'C, A''B'C$ and so on. Draw BN perpendicular to AA' . Produce AA' to D , where D is the image of B in the plane through B . Since $B'B = BD$, and $AN = AB$, the difference between $A'B'C$ and ABC is equal to ND , that is to

of the incident ray, ABC , is greater than ACB by the angle BCA , and so on.

If ABC is equal to the angle of the wave, or is any whole multiple of that angle, all the wave front reflected by the plane g, g, g will be the same plane and have constant curvature, and will together with ABC define the shape of the wave front, only by a sensible part, the wave front will be curved just as if plane surfaces with ABC were not the incident wave front, and the wave front will be the same as if the wave front were a plane, and the angle of the wave front is only when the plane angle is not a whole number of the angle ABC . These cases are given by

$$\begin{aligned} &1 + 2\theta \sin \theta, \\ &2 + 2\theta \sin \theta, \\ &3 + 2\theta \sin \theta, \text{ etc.} \end{aligned}$$

The reflection at the angle θ is called the reflection of the first order, that at the angle 2θ , reflection of the second order, and so on.*

If the crystal is slowly turned round in such a way that the plane angle θ is gradually increased, as general laws in an oblique beam. For as the angle increases the values $\theta, 2\theta, 3\theta$, there is a reflection of the ray. Finally when it reaches half of the angle, which is a different position of the crystal, more rays will only be reflected when

$$\begin{aligned} &1 + 2\theta \sin \theta, \\ &2 + 2\theta \sin \theta, \text{ etc.} \end{aligned}$$

*By analogy with the case of a plane wave front, the reflection of the first order is called the primary reflection, and so on.

If, therefore, we measure the angles θ_1 , θ_2 , θ_3 , at which reflection occurs, it gives us a relation between λ , the wave length and d , the constant of the grating. By employing the same crystal face, the wave lengths of different monochromatic vibrations can be compared. By using the same wave length, the distance d can be compared for different crystals and different faces of the same crystal.

In this way we may, on the one hand, investigate the structure of crystals, and on the other analyse a beam of X-rays. An instrument which detects and measures the reflection from a crystal face may be called an X-ray spectrometer. The next chapter will be devoted to a description of such an instrument; we are here concerned merely with the theoretical explanation of the reflection. In order, however, to gain some idea of the dimensions of the quantities involved, we may assume some of the results obtained with the spectrometer, and take as an example the reflection of palladium rays (*i.e.* the rays emitted by a palladium anticathode) by rock-salt. We shall prove later that the planes parallel to the face of a cube of rock-salt are equally spaced at intervals 2.81×10^{-8} centimetres. When the palladium rays are reflected from such a face there is a series of angles (5.9° , 11.85° , 18.15° ..., in a certain experiment), at which the reflection is exceptionally strong. It is clear that a monochromatic radiation is diffracted as 1st, 2nd, and 3rd spectra at these angles, for we note that $\sin 5.9^\circ : \sin 11.85^\circ : \sin 18.15^\circ = 1 : 2 : 3$ to a close approximation. The wave length being given

by the equation $n\lambda = 2d \sin \theta$, we have therefore, considering the first spectrum only,

$$\lambda = 2 \times 2.81 \times 10^{-8} \sin 5.9^\circ = .576 \times 10^{-8} \text{ centimetres.}$$

It is important to notice the relative magnitude of the grating constant d and the wave length λ . The former quantity may be so small compared to the latter that no value of θ can be found to satisfy the equation $n\lambda = 2d \sin \theta$, for $\sin \theta$ cannot be greater than unity. In the case we have considered, there is a wide margin. The value of the spacing is some five times larger than the wave length. The planes we have chosen are of a very 'simple' nature, and the spacing between them is large. As one proceeds, however, to consider the reflection from more complex planes of the structure, the spacing becomes smaller and smaller until finally d is so small that it is impossible to find an angle which satisfies our condition. The conditions under which the reflection of X-rays can take place are therefore very restricted indeed. Reflection is possible only when the spacing of the planes is large enough, and even then the planes must be inclined at exactly the right angle to the primary beam. It is the fact that we are dealing with the complicated case of a three dimensional grating which imposes all these conditions before it is possible to obtain a 'spectrum' of monochromatic waves.

To sum up now the analysis which we have made. When a pulse passes over the crystal, we have seen that it will be more or less strongly reflected by all the sets of planes on which the crystal particles can

be pictured as arranged. Its scattered energy will be concentrated in these special directions. If there are a series of pulses falling on the crystal, this will be true for each of them, so that on the whole the X-rays, if of this nature, will be diffracted along the 'reflection' directions. By a series of pulses we mean that the incident radiation contains no regular wave trains, that it is of a perfectly general nature, and is comparable to white light. However the crystal is oriented, the 'white' radiation is reflected in a series of little pencils, and it is these which made the spots in Laue's original interference photographs. Every set of planes reflects somewhat, but in general, as the planes become more complex in their nature, they reflect less and less, until the amount of reflection is too small to be detected. The apparent paradox that the crystal in one fixed position can reflect the pencil of rays in so many different directions is due to the fact that the so-called reflection is not a surface effect at all, but, owing to the penetration of X-rays, takes place throughout the whole volume of the crystal. The term reflection is only used because a convenient analogy with ordinary reflection gives the positions of the scattered beams.

When the light falling on the crystal is monochromatic, the effect is still more restricted. For each set of planes it is now only at a few special angles that reflection can take place at all, these being determined by the equation $n\lambda = 2d \sin \theta$.

It is this extra condition which distinguishes the

crystal grating from the ordinary line grating. The latter, at whatever angle the incident rays fall on it, gives a series of spectra. The crystal must be held at exactly the right angle, and even then can only give a spectrum of one order at a time. The reflection of the monochromatic vibration in this way gives more information about the crystal structure than the reflection of the white radiation. By observing the angles of reflection, we get a relation between λ and d , and by doing this for various faces of a crystal we gain an important insight into its structure. The X-ray spectrometer has already determined both the absolute wave lengths of various types of X-radiation and the arrangement of the atoms in several crystals.

CHAPTER III.

THE X-RAY SPECTROMETER.

THIS chapter contains a general description of the construction and use of an instrument designed to make use of the reflection principle which we have just discussed. It may be called the X-ray spectrometer.

The X-ray bulb shown in the accompanying drawing is enclosed in a wooden box coated with lead. The lead screening is a necessity. We find it well to employ a thickness of 2 mm. over the whole of the box, and in addition a special shield of 5 mm. thickness on the side of the box next the apparatus. The bulb is mounted so that it can be adjusted to an exact position. The centre of the fine pencil of rays which emerges from a slit in the side of the box should pass exactly through the axis of the spectrometer, and the source should be as nearly as possible a line parallel to that axis. For this reason the bulb should be so placed that the plane of the anticathode passes very nearly through the slits; the pencil of rays then leaves the anticathode at a grazing angle. A special form of bulb in which the anticathode is perpendicular to the stream of cathode rays is

especially convenient.* This arrangement greatly diminishes the evil effect of any wandering of the cathode spot over the surface of the anticathode.

The slit at *A* permits a fine pencil of rays to issue from the box. A second slit is often very useful; in

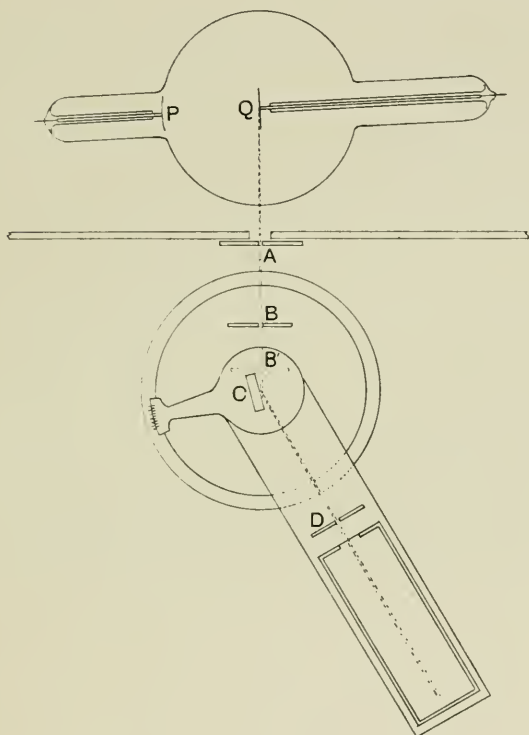

FIG. 4.

the drawing it is shown at *B*, but on occasions it may be placed as close to the crystal as possible. In the latter case it is used to define the width of the X-ray

* We owe the idea to Prof. R. W. Wood.

pencil ; in any position it helps to cut off stray radiation. The crystal *C* is mounted on a revolving table carrying an arm, at the end of which is a vernier working in conjunction with a graduated circle. The holder of the crystal is made to rock about a horizontal line, lying in the face of the crystal and passing through the centre of the spot where the rays strike it. This permits adjustment in case the reflecting planes of the crystal are found on trial to be out of the vertical. The crystal is mounted on a lump of soft wax, its position being generally determined by pressing the face to be used against a metal template which is afterwards removed.

The reflected pencil of X-rays passes into an ionisation chamber mounted so as to be capable of revolving about the same vertical axis as the crystal table. An adjustable slit *D* stands in front of the ionisation chamber. The chamber consists of a closed brass cylinder 15 cm. long and 5 cm. in diameter, made of stout brass tube and faced at the end where the rays enter with a lead plate. A hole in the centre of the plate is covered by a thin sheet of aluminium which transmits the reflected ray without much loss. The opening is large enough to take in a pencil 1 cm. wide ; but the width is often limited to very small dimensions by the slit at *D*.

The chamber is filled with a gas which absorbs the X-rays strongly, and so yields a large ionisation current. We have generally used SO_2 , which absorbs most rays about ten times as much as air. For the more penetrating X-rays methyl bromide is

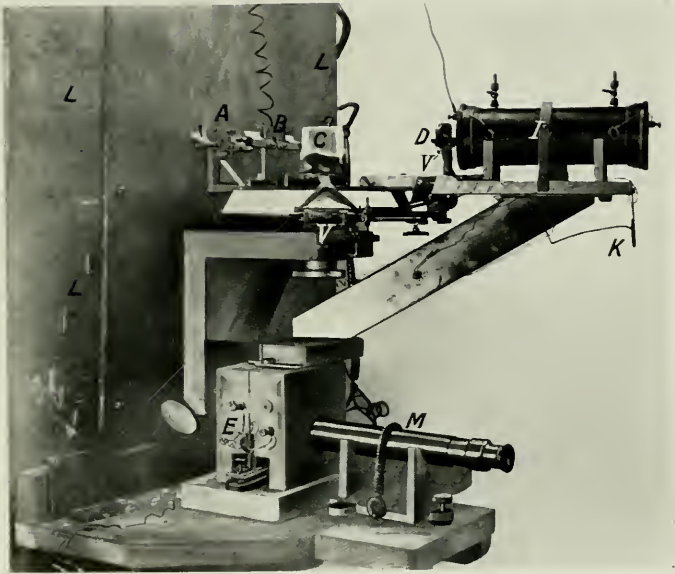

X-RAY SPECTROMETER.

- | | | | |
|-----------------|---------------------|------------|--------------------------------|
| <i>LLL.</i> | Lead box. | <i>V,</i> | Vernier of crystal table. |
| <i>A, B, D,</i> | Slits. | <i>V',</i> | Vernier of ionisation chamber. |
| <i>C,</i> | Crystal. | <i>K,</i> | Earthing key. |
| <i>I,</i> | Ionisation chamber. | <i>E,</i> | Electroscopes. |
| | | <i>M,</i> | Microscope. |

more effective than SO_2 . The chamber is insulated from the earth and raised to a high potential by a battery of storage cells. The electrode is mounted in the cylinder, just out of the way of the stream of rays which enter, and is connected through a mounting in a sulphur plug of the usual kind with a fine wire which leads to a Wilson tilted electroscope.

The wire is connected to the electroscope at a point immediately below and on the continuation of the axis of the instrument. The photograph (Plate II.) will make this clear. The object of this arrangement is to make it possible to turn the ionisation chamber about the axis without straining the connection with the electroscope. The connecting wire of the electroscope is electrically shielded by stout metal casings, which are earthed.

The Wilson electroscope is a convenient instrument to use: its sensitiveness can be adjusted to range over wide limits, and when all electrical conditions are sound, and the electrical shields are solidly built, the readings are extremely consistent, even when the sensitiveness is high. The electroscope works all the more satisfactorily because the tubes are best run in these experiments in a very 'soft' and steady state.

The arm of the chamber also carries a vernier which works on the same scale as that of the revolving table. It is convenient to be able to clamp the table and the chamber and to give motions to them over a small range by means of tangent screws, and in practice it is found to be a great convenience if

the heads of the tangent screws carry spokes like a capstan. It very often happens that during a series of observations the crystal must be moved from position to position at half the rate at which the chamber is moved, and with the arrangement described this can be conveniently done without the necessity of actually reading the verniers after every movement.

A key connects the electrode with earth. This being raised, and the X-rays turned on for a suitable time, the ionisation current flows into the electro-scope, and the consequent deflection of the gold leaf is read. From two to ten seconds is usually sufficient.

A strong reflected pencil will make the leaf move at the rate of ten or twenty scale divisions a second, and each division is readily divisible into ten by eye.

We may now proceed to consider various methods of using the spectrometer. It is sometimes very convenient to fix the crystal in some definite position and to move the ionisation chamber through a succession of small changes of position, recording the current for each position. Let S (Fig. 5) be the source, AB be the crystal: and let the slit of the ionisation chamber move over the arc CD . All the reflected rays appear to come from S' , the image of S in the line AB . For simplicity we suppose the reflecting layer to be very thin, so that S' may be assumed to be a point. In reality, it is drawn out into a line $S'S''$, which is a continuation of SS' . The rays reflected at A are of a wave length (considering

the reflection of the first order only) given by $\lambda = 2d \sin \theta$, where θ is the angle SAN . The waves reflected along BC have a wave length equal to $2d \sin SBN$, and so on. Thus the radiation is analysed into a spectrum along CD ; and if the various distances and angles are measured, the wave length of any particular ray can be determined in terms of $2d$, the constant of the crystal grating.

In this experiment the slit at A (Fig. 4) may be made narrow in order that it may be taken as the point

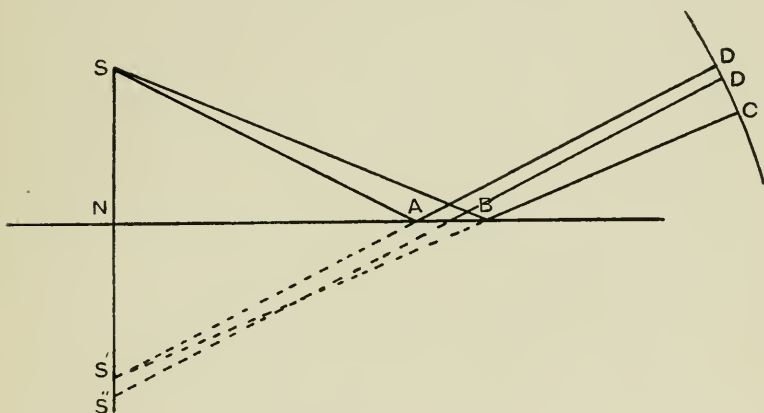

FIG. 5.

source S . The slit at B is not wanted, and may be left wide; the slit of the ionisation chamber must be narrow. Unless the cathode rays impinge on a rather large area of the anticathode, so that a pencil of some divergence passes through A , the range of the spectrum on CD (Fig. 5) is only small, but it is often quite sufficient. For example, in Fig. 6 the crystal is sylvine (KCl), and the table carrying the crystal

is set at such an angle that the primary rays passing through the axis make an angle of $5^{\circ} 40'$ with the crystal face. The ordinates of the

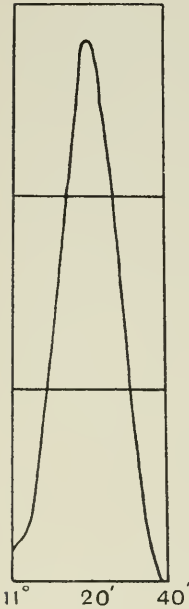

FIG. 6.

figure show the currents obtained at various settings of the ionisation chamber. The curve shows the existence of a strong radiation at $11^{\circ} 20'$, which is in fact the principal rhodium line.

If the source of the rays on the anticathode is fine enough, both the *A* and the *B* slits may be left wide. If the crystal is large and uniform, quite a considerable length of spectrum may be mapped in this way. A photographic plate may be used in place of the ionisation chamber: a method which has been employed by Moseley,* see p. 75. A variation of the photographic method has lately been used by de Broglie. As in Moseley's experiments, the plate replaces the ionisation chamber, but the crystal is made to revolve by clockwork slowly and uniformly. In this way a considerable range of spectrum is recorded at one time.†

In a second method crystal and chamber are moved together, the rate of motion of the latter being twice that of the former. In this case the

* *Phil. Mag.*, Dec. 1913 and April 1914.

† *C. R.*, Nov. 17, 1913, *et seq.* See also Herveg, *Verh. d. D. Phys. Ges.*, Jan. 1914.

reflection always occurs at that part of the crystal face which is near the axis, unless the crystal is very imperfect. The consequence of imperfections will be considered presently. Different portions of the same face are often out of alignment with each other, and it is more satisfactory to use the same part of the face throughout the whole series of measurements. The slit at *B* may be made narrow, in order to define the incident pencil more closely; but in the case of imperfect crystals the intensity of the reflection is diminished thereby.

This method has been largely used both for observing the spectra emitted by various anticathodes and for determining the constants of crystals. Many examples will be found in the following chapters.

In a third method the crystal is made to revolve while the ionisation chamber stands still, its slit being opened wide. In this case the incident pencil must be as fine as possible. For this purpose the slit *B* is pushed close to the bulb and made narrow. As the crystal moves, each wave length in the incident radiation is reflected in turn. An example is given in Fig. 7, which shows the reflection of the principal rhodium line by the (111) face of the diamond. The abscissae are the glancing angles at which the rays fall upon the diamond. The line is really a doublet, the two maxima being at $8^{\circ} 35'$ and $8^{\circ} 39'$ as marked on the figure. Each point in the diagram represents the result of a separate observation. The crystal is a good one, and the reflection of each homogeneous ray is complete within a range

30 THE X-RAY SPECTROMETER

of ten to twelve minutes. The slit at *B* was 0.3 mm. wide, and was at a distance of 20 cm. from the anticathode. The incident pencil had therefore itself a divergence of at least $\frac{3}{2000}$, or a little more than five



FIG. 7.

minutes of arc. The anticathode spot had a certain width which further increased the small divergence. Thus the extent of the range of reflection is largely, if not entirely, accounted for. No want of precision of the angle of reflection is made apparent, and the crystal appears to be almost perfect.

The principal objects in view, when choosing a method of observation, are intensity and sharpness of definition or resolving power. The two are not always compatible with each other. In considering the question, certain geometrical relations are of importance, and these we will now consider.

Suppose the rays to issue from a point source (*O*) (Fig. 8) which may be the anticathode spot, or the

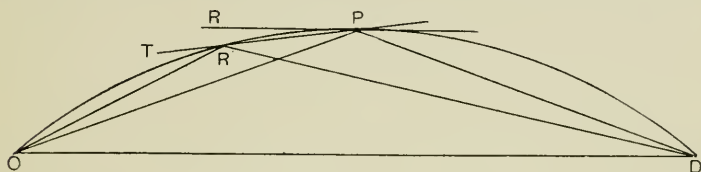

FIG. 8.

slit at *A* in the wall of the box. Let the crystal face be in the position PR , P being on the axis of the spectrometer. Let the ray OP be reflected to D , the slit of the ionisation chamber. Let PR' be a second position of the crystal face, the crystal having been turned through the angle RPR' . Let R' be the intersection of PR' with a circle through OPD . The angle $OR'T$ is equal to the angle ODP , and the angle $PR'D$ to POD . Also $OR'D = OPD$. Consequently if OP is made equal to PD , that is to say, if the source and the ionisation chamber slit are at the same distance from the axis of the instrument, the angles made by OR' and $R'D$ with the position $PR'T$ of the crystal face are the same as those made by OP and PD with the face in the position PR . If a ray of wave length λ is reflected along PD in the one position of the crystal, it is reflected along

$R'D$ in the other. The crystal in quite different positions reflects the ray to the same point D . Thus the position of the ionisation chamber where a certain wave length can enter it is far more sharply defined than the position of the crystal which reflects it: provided, of course, that the incident pencil is divergent enough to include both the direction OP and OR' . This is a very important consideration, since it shows us that we may obtain a sharply-defined or pure spectrum, even when the original pencil is not limited to a very small divergence.

There is another point to be considered. Crystals are often imperfect. They appear to consist of a multitude of small and more perfect crystals put together somewhat imperfectly. Consequently reflection of a homogeneous ray does not take place exactly on a vertical line on the crystal face, but at a number of points scattered over the face and grouped most densely near the vertical line. If the rays were visible, an eye placed at the ionisation chamber slit would see an effect like that of light reflected by slightly rippling water. To make the comparison complete, it would be necessary to imagine the light to be capable of reflection at one angle only: so that the eye would only see this effect at its best in one position, and if it moved would soon cease to see any reflections at all.

Let PQ in Fig. 9 represent the crystal face reflecting the ray OP of a certain wave length along PD , as in Fig. 8. Suppose that at Q there is a small crystal element set at a slight angle to the face

PQ , and also reflecting the same ray. Let us find to what point it reflects it. Join OQ , meeting the circle through OPD in R' . We know that the ray OR' would be reflected by the crystal if its face was

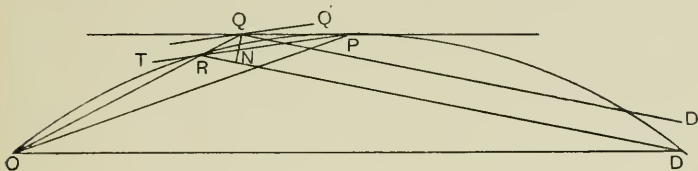

FIG. 9.

in the position $PR'T$. Consequently the face of the reflecting element at Q must be parallel to PR' , and the reflected ray QD' must be parallel to $R'D$.

Let $OP = L$, $PQ = l$. Draw QN perpendicular to $R'D$. The triangles OQP and PQR' are similar, for they have a common angle at O , and the angles $PR'Q$ and OPQ are equal to each other, being each equal to the glancing angle of reflection for the ray in question, which may be put equal to θ .

Hence $QR' = l^2/L$, and $QN = l^2 \sin 2\theta/L$.

This quantity is usually quite small. If, for example, l was as much as 1 cm., L equal to 12 cm. and 2θ to 20° ,

$$\begin{aligned} QN &= .342/12 \\ &= .028 \text{ cm.} \end{aligned}$$

The ray reflected at R' would pass by D at a distance of a third of a millimetre only, and the slit at D need only be opened to that extent to take in such rays.

When, therefore, a crystal is not very regular in

its general construction, the intensity of the radiation entering the slit at D is much increased by widening the incident pencil; that is to say, by opening the slits at A and B . For example, in a certain case the intensity of the third order reflection of the principal rhodium ray by galena was increased three times by the removal of the slit B , which had been placed close to the crystal, and had been opened to the extent of three-tenths of a millimetre. Under similar circumstances, the intensity of the ray reflected by the diamond was very little affected.

That the galena is a less perfect crystal may also be seen by comparing the curve of Fig. 10 with the curve of Fig. 7, which were obtained under exactly

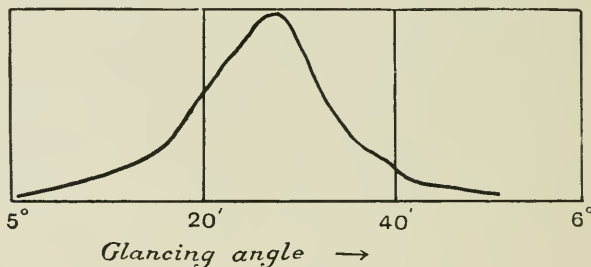

FIG. 10.

the same circumstances, except for the change of crystal. In each case the slit B was close to the crystal and 0.3 mm. wide. The crystal alone was rotated. The angle at which the diamond must be set in order to reflect the fine incident pencil is restricted to much narrower limits than in the case of the galena, showing that the latter had a more irregular face. In other words, the smaller crystals

which go to make up the larger were put together in less exact alignment with each other. In Fig. 11 is shown the reflection of the same rhodium line from a badly distorted piece of rock-salt: the slit at *B* was

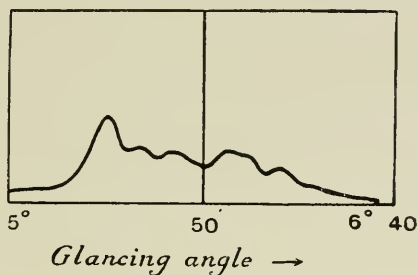

FIG. 11.

only 0.1 mm. wide in this case, and the irregularities are intensified by the use of so fine a pencil of X-rays.

At the same time it is clear from the above geometrical considerations that the rays reflected from various parts of the crystal face all pass very close to the slit at *D*. The purity of the spectrum is not seriously affected when, in order to increase the intensity of reflection from an imperfect crystal, we open the slits at *A* and *B*.

From the preceding paragraphs we may draw the general result that the method of observing the reflection by the face of a crystal gives a purity of spectrum which is remarkably independent of the divergence of the incident rays, and of irregularities in the crystal.

It is not possible in all cases to use an exposed or developed crystal face. A crystal may not possess

the particular face that is to be investigated, and it may be inconvenient or impossible to prepare it artificially. The reflection must be studied as it takes place within the crystal: and the crystal must be placed in position without the use of the template. For example, we have been obliged to observe the reflection by the dodecahedral planes of the diamond in the manner shown in Fig. 12. The diamond which we have used consists of a slip 6 mm. wide and 0.4 mm. thick, its faces being octahedral planes.

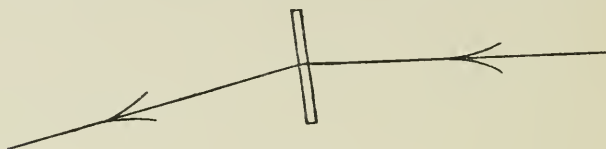

FIG. 12.

Six dodecahedral planes are perpendicular to each octahedral plane; e.g. the planes $(1\bar{1}0)$, $(\bar{1}10)$, $(10\bar{1})$, $(\bar{1}01)$, $(0\bar{1}1)$, $(01\bar{1})$ are all perpendicular to the plane (111) . The figure may be considered to show reflection at one of such six planes.

Since the angle of reflection of a homogeneous ray is a constant quantity, the place of reflection moves quickly across the diamond as we turn the crystal round; the ray turns about the source at the same rate as the crystal. In this case, therefore, the position of the ionisation chamber, when placed to admit the reflected ray, depends directly on the setting of the crystal. The setting of the ionisation chamber can be varied between limits which increase with the divergence of the incident

rays: it is no longer, as in the previous disposition, almost independent of the divergence of the rays and of irregularities in the crystal. If quantitative measurements are desired, the incident pencil must be fine.

There is one further consideration which is of importance in connection with the ability of the spectrometer to separate two homogeneous rays of nearly equal wave lengths, that is to say, with its resolving power. We know that $n\lambda = 2d \sin \theta$. If two wave lengths differ slightly, the difference in the corresponding values of $\sin \theta$ is proportional to the order of the spectrum considered. But there is an

additional advantage in the use of a high order. An angle grows faster than its sine, especially when the angle is large. This can have a large effect on the resolving power.

In fact,

$$d\theta/d\lambda = n/2d \cos \theta = \tan \theta/\lambda,$$

which becomes infinite when

$\theta = \pi/2$. For instance, Fig. 13 shows the third order spectrum of two platinum lines given by diamond (111). In the first order spectrum the separation is 30'. Here it is 2° 30', and the resolution is complete, although the slits were all 2 mm. wide.

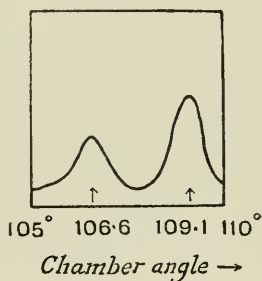

FIG. 13.

CHAPTER IV.

THE PROPERTIES OF X-RAYS.

IN this chapter we shall describe some of the properties of the X-rays, taking our stand at the point which had been reached before the recent discoveries. We shall confine ourselves mainly to the consideration of such properties as are important to the present discussion, or are illuminated by the newer work.

X-rays are produced by bombarding metal plates, usually of platinum or tungsten, by electrons to which a high velocity has been imparted by the electromotive force of an induction coil. The process can only be efficiently carried out in the partial vacuum of an exhausted glass 'bulb.' The cathode P (see Fig. 4, p. 23) is connected to the negative terminal of the coil, and so becomes the origin of the fast-moving electrons or 'cathode rays.' The bombarded plate, or anticathode, is denoted by Q .

The conditions of working depend greatly on the amount of gas left in the bulb. If there is too much, it is found that the supply of electrons is plentiful, so that it is easy to pass current through the tube, and the electromotive force is not driven to high values. The speed of the electrons is slow, and the X-rays

which they produce are found to have little penetrating power. The bulb is said to be 'soft.'

On the other hand, if the vacuum is too high, and it generally tends to rise as the bulb is used, the supply of electrons falls off. The electromotive force then rises, the electrons acquire greater speeds, and give rise to more penetrating X-rays. The bulb is then said to be 'hard.'

A pencil of X-rays issuing from an X-ray bulb is generally of very mixed composition. This is evident, because, if screens of various materials and thicknesses are placed in the path of the rays, the absorption is not governed by any simple or regular law.

Nevertheless, it is possible to obtain pencils of X-rays which may be considered to be homogeneous. In a series of highly important investigations, Barkla and his fellow-workers showed that every substance under proper stimulus emitted an X-radiation which was homogeneous and characteristic of that substance. In certain cases a substance could emit two homogeneous radiations of different quality. It may be said at once that the newer work shows that these characteristic radiations are not quite so simple as they have appeared; but substantially Barkla's conclusions as to the existence and means of producing the secondary radiations have been entirely confirmed.

The necessary stimulus required to make a substance emit its characteristic X-rays is provided by irradiating the substance in question with X-rays of a penetrating power which must—so experiment

shows—be at least a little greater than that of the rays which are to be produced. The exciting or ‘primary’ rays may be those issuing from an X-ray bulb, or be ‘secondary’ rays from some other substance. The work of Kaye, Whiddington, Beatty, and others has shown that the characteristic rays are also excited if the substance is made the anticathode of an X-ray bulb, and bombarded by cathode rays of sufficient velocity.

A ‘homogeneous’ radiation loses successively equal fractions of its energy when it passes in succession through a series of similar layers of the same material. Mathematically we say that if I measures the energy in a homogeneous pencil of X-rays which is moving in a certain direction through any substance, and if the energy diminishes by δI in moving a distance δx in that direction, then δI must be proportional to $I\delta x$.

If, therefore, we put $\delta I = -\lambda I\delta x$ where λ is the constant of absorption, we have $I = I_0 e^{-\lambda x}$; expressing the amount I to which an initial amount I_0 has fallen after traversing a distance x in the material in question. The constant λ is called the absorption coefficient.

We can also write this in the form

$$I = I_0 e^{-\frac{\lambda}{\rho} \cdot \rho x},$$

introducing ρ , the density of the material. The quantity λ/ρ is called the ‘mass absorption coefficient’: it expresses the ratio of the proportionate loss of energy in crossing a thin layer at right angles

to the weight of that layer in grams per square centimetre. The constant λ/ρ is far more useful than λ itself, because it is found that a layer of given material and given weight per square centimetre absorbs the same fraction of X-ray energy, no matter what its density may be. For instance, a slab of ice absorbs just the same amount if it is melted, the weight per square centimetre remaining the same. In what follows the term absorption coefficient must be taken as meaning mass absorption coefficient.

The quality of a homogeneous beam may therefore be defined by its absorption coefficient in some standard substance. For all qualities usually met with it is found that aluminium is a convenient substance to choose; it does not show within a wide range any of the abnormalities which many other substances do.

In the table appearing on page 42 are given the absorption coefficients in aluminium of the radiations characteristic of a number of substances. The table is taken from a paper by Barkla.

It will be observed that experiment has led to the recognition of two series of radiations, and that within any one series the penetrating power of a characteristic radiation increases steadily with the weight of the atom which produces it. Some substances emit radiations of two qualities, one from each series. In the case of other substances only one has been observed. Extrapolation shows that the observation of a second in such cases could not be expected, it would either be so hard that

42 THE PROPERTIES OF X-RAYS

Radiator.	Atomic Weight.	Absorbability of Fluorescent Radiation ($\frac{\lambda}{\rho}$ in Al).		Remarks.	
		Series K.	Series L.		
H-Mg	1.008-24.32	—	—	No radiation observed: probably very absorb- able.	
Al....	27.1	—	—	} Effects of fluorescent ra- diation observed: mea- surements not made.	
S.....	32.07	—	—		
Ca ...	40.09	435	—	Not so accurate as values below.	
Cr ...	52	136	—	} Easily observed and homogeneity proved with considerable accu- racy.	
Fe ...	55.85	88.5	—		
Co ...	58.97	71.6	—		
Ni ...	58.68 (61.3)	59.1	—	} For atomic weight of Ni see paper by Barkla & Sadler (<i>Phil. Mag.</i> Sept. 1907).	
Cu ...	63.57	47.7	—		
Zn ...	65.37	39.4	—	} Not accurately deter- mined for Rb.	
As ...	74.96	22.5	—		
Se ...	79.2	18.9	—		
Br ...	79.92	16.4	—		
Rb ...	85.45	13.7	—		
Sr ...	87.62	9.4	—		
Mo ...	96.0	4.7	—		
Rh....	102.9	3.1	—		
Ag ...	107.88	2.5	700		} Owing to two fluorescent radiations total radi- ation appears very vari- able in experiments with primary radiation of ordinary penetrating power. Series L not obtained with accuracy of series K.
Sn ...	119.0	1.57	—		
Sb ...	120.2	1.21	435		
I ...	126.92	.92	306		
Ba ...	137.37	.8	224		
Ce ...	140.25	.6	—		
W ...	184.0	—	33		
Pt ...	195.0	—	27.5	} Homogeneity not shown with accuracy, conse- quently values of absor- bability only approxi- mate,—possibly rather high.	
Au ...	197.2	—	25		
Pb ...	207.1	—	20		
Bi ...	208	—	19		

it would go through the gas of the measuring chamber with negligible effect, or so soft that it could not reach the chamber at all. It will be seen that a wide range of qualities is at our disposal.

The next table is well-known : it is taken from a paper by Barkla and Sadler, and is most instructive :

Mass absorption coefficients $\left(\frac{\lambda}{\rho}\right)$.

Radiator.	ABSORBER.										
	C.	Mg.	Al.	Fe.	Ni.	Cu.	Zn.	Ag.	Sn.	Pt.	Au.
Cr	15.3	126.5	136	103.8	129	143	170.5	580.5	713.7	[516.8]	[507+]?
Fe	10.1	80	88.5	66.1	83.8	95.1	112.5	381	472	340	367
Co	7.96	63.5	71.6	67.2	67.2	75.3	91.5	314	392	281	306
Ni	6.58	51.8	59.1	314	56.3	61.8	74.4	262	328	236	253
Cu	5.22	41.4	47.7	268	62.7	53.0	60.9	214	272	194	210
Zn	4.26	34.7	39.4	221	265	55.5	50.1	175	225	162.5	178.2
As	2.49	19.3	22.5	134	166	176	203.5	105.3	131.5	105.7	106.1
Se	2.04	15.7	18.9	116.3	141.3	149.8	174.6	87.5	112	93.0	100.0
Ag	.41	2.2	2.5	17.4	22.7	24.3	27.1	13.3	16.5	56.5	61.4

It shows in the first place that there are large discontinuities in the run of the absorption coefficients. If we take as an example the powers which nickel possesses of absorbing the various radiations, we find that over a certain range they decline steadily with the increase in atomic weight of the radiator. In fact they are proportional to the absorption co-

44 THE PROPERTIES OF X-RAYS

efficient of aluminium for the same radiations. The absorption coefficient for nickel rays is the least of all ; then comes a sharp rise, and the absorption coefficient for Zn rays is five times what it was for Ni rays. From this higher level a regular decline again sets in. A little calculation will show that the absorption coefficient in any substance is now approximately eight times what it would have been had the rise not been made. This is easily seen if we divide the absorption coefficients of metal by those of aluminium as in the following table :

RATIOS OF ABSORPTION COEFFICIENTS OF VARIOUS RADIATIONS
IN Ni AND Al.

Cr	-	-	0.949		Cu	-	-	1.314
Fe	-	-	0.947		Zn	-	-	6.7
Co	-	-	0.939		As	-	-	7.29
Ni	-	-	0.953		Se	-	-	7.42

These changes which we have considered in the case of nickel as an absorber are shown in the same way by other substances. Even the factor eight recurs with some regularity.

The next point to be considered—a little more closely than we did above—is that in order to stimulate a substance to emit its characteristic X-rays, it is found necessary to use rays more penetrating (as measured in aluminium) than those which it emits itself. For example, nickel rays can be excited by Zn rays, or by any rays more penetrating than Zn rays: not by Ni rays or any rays less penetrating. They cannot even be excited by Cu rays; there

seems to be some evidence that rays of a substance *A* can be excited by rays of a substance *B* when *B* is at least two places higher than *A* in the table of atomic weights.

This helps us to understand why the high absorption coefficients set in at certain definite points. The Zn rays are the least penetrating of those which can excite Ni rays, and Zn is the lightest atom whose rays are absorbed by Ni on the higher scale. The sudden increase of absorption coefficient and the power to excite secondary rays appear together.

Yet the increase of the absorption coefficient is not entirely due to the expenditure of energy in the production of secondary radiation. X-rays, when their energy is absorbed in any substance, produce 'cathode rays';* that is to say, they set in motion electrons, which, taking their origin in atoms of the substance, move off with a velocity of the same order as that of the cathode rays of the X-ray bulb, and spend their energy in producing ionisation. It is this ionisation, produced in the gas of the ionisation chamber, which we measure in the electroscope. The X-rays do not apparently contribute directly to the ionisation, nor do any secondary rays which they set up: in all cases the 'cathode rays' must play

* So called because they have initial velocities of the same order as the electrons constituting the cathode rays of the X-ray bulb. The close relation between the velocities of the two classes of electron motion constitutes one of the most remarkable and least understood phenomena of X-radiation. The speed of the secondary cathode ray is generally somewhat less than the speed of the primary ray, but never exceeds it.

their part. The most obvious illustration of these facts is given by C. T. R. Wilson's beautiful 'fog-pictures,' in which the tracks of the ionising cathode rays are made visible, and there is no trace of any ionisation caused by the X-rays to which the cathode rays are due.*

Now we find that the sudden increase of the absorption coefficient to which we have drawn attention above is marked not only by the appearance of the power to excite secondary X-rays, but also by the excitation of cathode rays in far greater numbers than before. For example, when the X-rays characteristic of iron or nickel or copper pass through a nickel plate, there is a certain production of cathode rays. They are easily observed to be emerging from the plate on both sides and penetrating to a small distance, a fraction of a millimetre, into the air. But when zinc rays are made to pass through the same plate, three striking changes are observed: the absorption is very greatly increased, there is a production of the characteristic nickel radiation, and a large increase in the cathode radiation. This fact is of great moment to us: we will give an illustration presently.

We must take note of one other important phenomenon in connection with absorption. The relations of X-rays to matter have been found to be entirely independent of the physical or chemical condition of the matter. The absorption coefficients are, for example, independent of temperature. They are

* *Proc. Roy. Soc.* 1912.

independent even of chemical association: for example, the absorption coefficient of sodium chloride can be found immediately from the absorption coefficients of sodium and chlorine without any need to consider the question of molecular composition.

It will be very interesting to consider whether the new experiments constitute a breach of these rules, and if so, in what way.

The laws relating to absorption coefficients which we have set down are of great importance in the newer work. If, for example, we measure the intensity of reflected X-rays by means of an ionisation chamber, or a photographic plate, or a fluorescent screen, we have to bear in mind that the nature of the gas in the chamber, or of the materials of the plate or screen, will have a great influence on the sensitiveness of the detector in different parts of the spectrum. Sulphur dioxide absorbs all rays of the usual range of quality several times more than air; there is a correspondingly larger increase of ionisation throughout the whole spectrum if this gas is used in the ionisation chamber. If we use methyl bromide, we greatly enhance the effect of all those rays, which are penetrating enough to excite bromine secondary rays, and at the same time produce an especially large quantity of cathode rays, and so of ionisation. In the case of the less penetrating rays from a bulb with a platinum anticathode, methyl bromide is little better than sulphur dioxide. But in the case of rhodium rays, it is several times better.

So, again, if we use photographic methods, a photographic plate containing a silver salt will record with far greater intensity all those rays which are highly absorbed by silver and excite an extra quantity of cathode rays than those which do not. On one side of a sharply dividing line the more penetrating rays leave a record which is greatly reinforced in comparison with the record of the less penetrating rays on the other. We shall refer to this point later.

As we go on, we shall find other cases in which we must take account of the peculiarities of the absorption coefficients.

We have stated that X-rays, in passing through any substance, always excite cathode rays and sometimes the X-rays which are characteristic of that substance. There is another way in which the energy of the primary beam suffers loss. It is 'scattered' without transformation; that is to say, X-rays of exactly the same quality as the primary are found to be travelling outwards in all directions from the substance which the primary rays traverse. The proportion of the primary energy diverted in this way is small, even when the excitation of characteristic X-rays and the accompanying excessive production of cathode rays are not taking place. It is quite negligible when these latter processes are going on.

This concerns us in two ways. In the first place, primary rays are scattered at the edges of screens and slits, and in other places on the spectrometer. It is important to know that in practice the effect

of these scattered radiations is so small as to be negligible.

The second point is theoretical. Barkla has found that atoms of small atomic weight scatter radiation energy in proportion to their weight.* On the other hand, Crowther † states that this law holds approximately only for the smaller atoms and not at all for the larger, which scatter more vigorously than according to Barkla's rule.

On the other hand, it will be shown in a later chapter that in order to explain certain effects which will be described, an atom must be supposed to contribute to the *amplitude* of the scattered waves in proportion to its weight. Since the energy of wave motion varies as the square of the amplitude, there is an apparent divergence between the various experimental results which remains to be explained.

The statements in this chapter constitute by no means a full record of X-ray phenomena; but they are perhaps sufficient for our present purpose.

* *Phil. Mag.*, May, 1904.

† *Camb. Phil. Soc. Proc.*, Dec. 1, 1911.

CHAPTER V.

CRYSTAL STRUCTURE.

THE atoms and molecules of the substances composing a crystal are arranged in a definite pattern. It is this arrangement which distinguishes a crystal from a block of the same substance in the amorphous state. The crystal form, displaying itself as a polyhedron bounded by plane faces, is generally assumed whenever a substance is deposited as a solid from solution, or from the molten or vaporous state. When the atoms are, as it were, given an opportunity to arrange themselves, they adopt a geometrical disposition of perfect regularity. Each chemical compound has its own crystalline form, by which in most cases it may be identified.

Crystals have been grouped into systems and classes on the evidence of their external form alone. Until quite recently nothing definite has been known concerning their internal constitution, though several theories have been put forward to explain the external forms by assigning various arrangements to the atoms. Nevertheless it has been possible, without any exact knowledge of crystalline structure, to lay down certain geometrical laws to which all such

structures must conform, simply because they are 'patterns' in space. We can investigate and classify the different ways in which it is possible to make a space-pattern. It is important to observe that in this way we arrive at a classification which is exactly the same as that to which we are led by actual observations of outward forms. It is believed that the geometrical theory of crystal structure is now complete, and that further advance must be made by experimental discoveries concerned with actual crystals.

Let us suppose we take a crystalline structure, and group its atoms into the little units of pattern mentioned above. The groups are to contain as few atoms as possible, consistent with the requirement that the whole crystal can be built by packing these groups together, all the groups being similar and similarly oriented. If a point is now chosen in each of the groups in the same way, for example the centre of a particular atom, these points serve to indicate the positions of the groups to which they belong. Thus by neglecting the complicated structure of atoms surrounding each point, and considering the points alone, we arrive at a series of points in space which form the foundation on which the crystal is built. Such a series of points is of the greatest importance in the theory of crystal structure: it is known as a 'Space Lattice.'

In order that a set of points in space may form one of these space lattices, they must satisfy certain conditions. Since the points have been chosen in

the same way from each unit of the pattern, it follows that every point must be situated similarly to every other point; each has neighbours in the same directions and at the same distances from it. All ways of drawing points in space which satisfy these conditions reduce in the end to the following method. Space is divided into parallelepiped cells by three sets of parallel planes. The planes belonging to a set are all equidistant and parallel, but the distance between the planes need not be the same for all three sets, and the planes of different sets may make any angle with each other. By taking every point where three planes meet, we form a lattice which satisfies the conditions stated above.

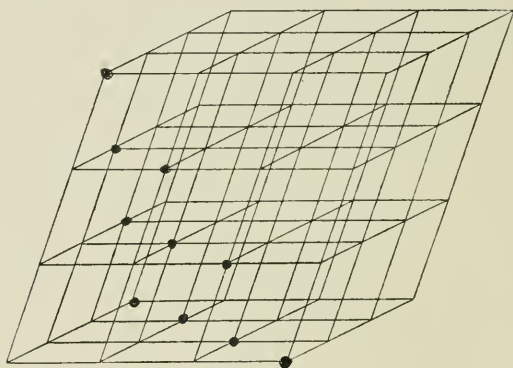

FIG. 14.

Suppose now that Fig. 14 represents the space lattice actually underlying a crystal that we are measuring. It is clear that the orientation of any face which the crystal may possess is determined by the lattice alone and not by the pattern unit which

is grouped round each point. The faces of the crystal represent possible ways of arranging points of the space lattice in planes (compare p. 12, Fig. 2). For instance, in Fig. 15, we have a series of points lying in the plane ABC , the parallelepipeds being pictured as bricks packed so as to show this plane, which is known as a 'net plane' of the structure.

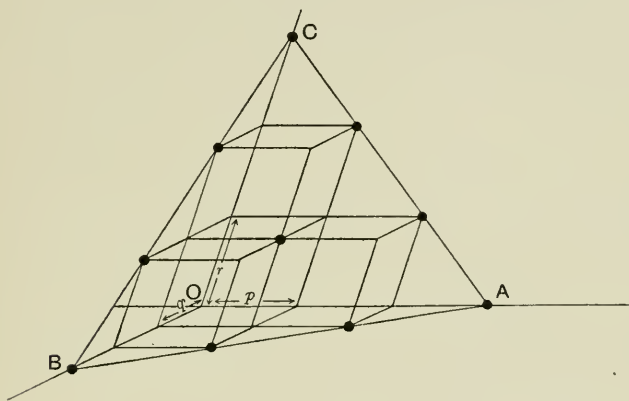

FIG. 15.

The same points can be arranged in any number of ways on parallelepipeds, those in the figure representing only one possible way of carrying out the arrangement. Let us, however, choose some particular way of drawing the parallelepiped. We may then call the three directions to which the edges of the parallelepiped are parallel, the *axes* of the crystal, and all its faces can be named with reference to these axes. The way in which the planes are referred to the axes is as follows. In Fig. 15 we have drawn a typical plane ABC on which a set of particles lie. Let

O be the origin at a parallelepiped corner, and OA , OB , OC parallel to the axes of the crystal. The plane ABC cuts off the intercepts OA , OB , OC from the axes, and if we know the ratio of these intercepts, we can thereby define the orientation of the plane ABC . (It will be evident from Fig. 15 that net planes of all types can be drawn by choosing for OA , OB , OC any multiples of the parallelepiped edges.) If we call these edges p , q , r respectively, then the ratio $\frac{OA}{p}$ must be a whole number. Similarly, $\frac{OB}{q}$ and $\frac{OC}{r}$ are whole numbers. We see, therefore, that we can write

$$\frac{OA}{p} : \frac{OB}{q} : \frac{OC}{r} = N_1 : N_2 : N_3,$$

where N_1 , N_2 , N_3 are whole numbers. We may also put

$$\frac{p}{OA} : \frac{q}{OB} : \frac{r}{OC} = N_2 N_3 : N_3 N_1 : N_1 N_2,$$

the last three quantities being again whole numbers. These are the ratios which are used by crystallographers when they wish to designate any particular plane of a crystal. The numbers are divided by any common factor, so as to make them as simple as possible, and finally, if

$$\frac{p}{OA} : \frac{q}{OB} : \frac{r}{OC} = h : k : l,$$

the plane in question is defined as the plane (h, k, l) , the indices being written in brackets.

For the plane drawn in Fig. 15,

$$\frac{OA}{p} = \frac{OB}{q} = \frac{OC}{r},$$

and the plane is represented by indices (111). The intercepts which this plane makes on the axes are proportional to the sides of the elementary parallelepiped. The ratios of these three quantities are then called the *axial ratios* of the crystal. The axial ratios are denoted by the symbols a , b , c , and since it is merely ratios that we require, b is usually put equal to 1. We have

$$a : b : c = a : 1 : c = p : q : r.$$

In the case of an actual crystal the ratios $a : b : c$, and the angles the axes make with each other are determined as the result of measurement of the inclination of the crystal faces to each other. There is, however, a certain freedom of choice, which is so made that the indices of the most important faces have simple values. When we have chosen suitable axes, and some well marked plane to be called the plane (111), the intercepts which this plane makes on the axes then give the ratios $a : b : c$. We may now proceed to determine the indices of all the other plane faces of the crystal, and it is not difficult to see, from the above example, that all these faces will have a set of indices (h, k, l) which are integers.

Let us take as an example the naming of the faces of a cubic crystal. Such a crystal has three equal axes at right angles, represented by OX , OY , OZ in Fig. 16. If the crystal were bounded by a face

parallel to $EGFA$, this face would be named the face (100) . For since the face is parallel to two of the axes, the intercepts it makes on these two are to be regarded as infinite, so that the three intercepts are in the ratio $OA : \infty : \infty$, and the inverse of these numbers gives the indices $h : k : l = 1 : 0 : 0$. The face $CEFB$ is parallel to the X axis, and makes

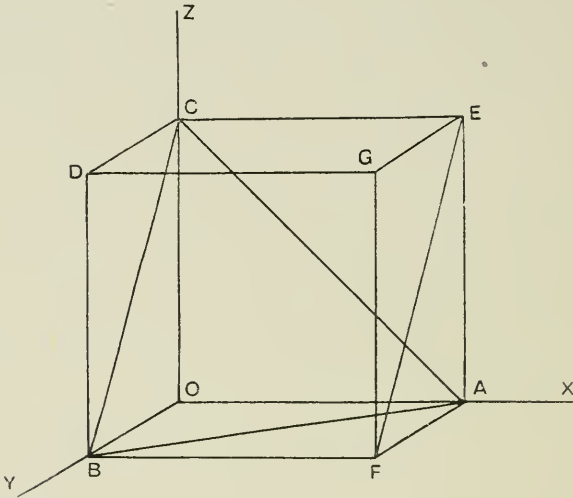

FIG. 16.

equal intercepts on the Y and Z axes. It has indices (011) . The face ABC makes equal intercepts on all three axes, and is therefore the face (111) . Now the crystal may have two faces on opposite sides parallel to ABC . We distinguish these faces from each other by calling them (111) and $(-1, -1, -1)$ respectively, the latter being written $(\bar{1}\bar{1}\bar{1})$. If the body of the crystal is on the same

side of ABC as the origin in Fig. 16, this plane is called (111) , the opposite face being called $(\bar{1}\bar{1}\bar{1})$.

To return to the space lattice. In general the sides of the elementary parallelepiped of Fig. 14 may be of any length and be inclined at any angle to each other. As a special case, the three sides might be equal and make right angles with each other. If this were so, the parallelepiped would become a cube, as in Fig. 17 (*a*).

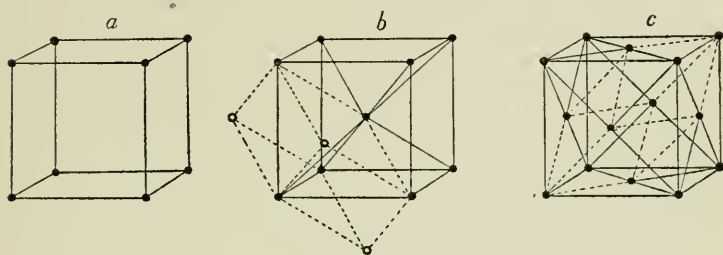

FIG. 17.

A crystal built up on such a lattice as this will have a cubic character, that is to say, it can be referred to three identical axes at right angles, and therefore belongs to the cubic system of crystals. But on examining all the ways of arranging points on space lattices, we find two more, each of which can be referred to the cubic system of axes, although its elementary parallelepiped, which is shown by dotted lines, is not cubic. These are shown as (*b*) and (*c*), Fig. 17. They may be represented respectively by a cube with points at the corners and cube centre, and a cube with points at the corners and the centres of the cube faces.

It is to be remembered that these diagrams only represent the units of the lattice, which is to be pictured as extending by a repetition of these units in all directions in space. It is clear that (b) and (c) have cubic symmetry as well as (a). It is not so clear at first sight that the points of b , or of c , are all identical, but this is really the case. If, for instance, the structure (b) is continued in space, it is evident that the distinction between cube corners and cube centres is quite arbitrary; the points are identical in all respects.

Investigation shows that these are the only three space lattices which have cubic symmetry. They are known as the cubic, the centred cubic, and the face-centred cubic lattices.

The cubic lattices possess certain elements of symmetry which are characteristic. These we must now proceed to consider.

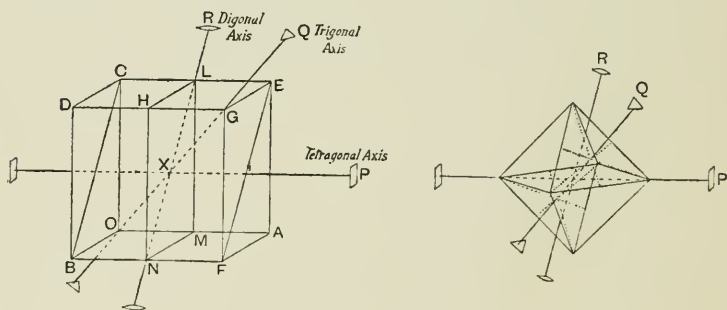

FIG. 18.

Fig. 18 represents an element of the cubic space lattice. The line P which is drawn through the centre of the cube parallel to the cube edge is called

an axis of fourfold symmetry, or a tetragonal axis. If the whole space lattice is turned around this axis through a quarter of a revolution, it is brought to self-coincidence; that is to say, the completed operation has made no apparent change. The line Q is an axis of threefold symmetry, or a trigonal axis. A revolution of $2\pi/3$ brings the space lattice to self-coincidence. A line such as R is an axis of twofold symmetry, or a digonal axis.

There is another form of symmetry which the structure possesses. The plane $EFBC$ is such that the points on one side of it are the reflections in it of points on the other side. It is called a plane of symmetry. $HLMN$ is also such a plane.

Lastly, the centre of the cube is a centre of symmetry. To every point of the structure there corresponds another point which is equidistant from the centre of symmetry, the two points and the centre being collinear. Such centres are also situated at the cube corners, as may be seen by imagining the lattice of Fig. 17 to be extended.

There are similar planes and axes otherwise situated in the lattice, but this enumeration is sufficient for present purposes.

Suppose a crystal to be built up on one of these space lattices. In a simple case, a single atom of some element may be imagined to be placed at each point of the lattice, and to avoid complications, let the properties of the atom be independent of directions in space. If the crystal is allowed to grow quite freely under ideal conditions,

it will develop in such a way as to show the underlying symmetry of the space lattice. If the face (100) of the crystal grows at a certain rate, the face (010) and (001) will grow at the same rate, for they are of the same kind, and the crystal will develop as a perfect cube. If, instead, it is the face (111) which grows in preference to others, the crystal will grow seven other faces $(11\bar{1})$, $(1\bar{1}1)$, ... $(\bar{1}\bar{1}\bar{1})$ at the same rate, and will become an octahedron.

When a crystal has a complete series of faces of one kind such as this, the set is called a 'form,' and it is written $\{111\}$ in curly brackets. Any one cubic crystal may have a variety of shapes, composed of different forms and combinations of forms. One feature will be common to the crystals: all their forms will display the symmetry of the lattice. For instance, we will now suppose that the cube in Fig. 18 represents, not an element of the structure, but an actual crystal which has grown under ideal conditions into a perfect cube by developing faces $\{100\}$. Beside it there is another cubic crystal (Fig. 18) which has developed into an octahedron. It will be seen that the octahedron has the same axes, planes, and centre of symmetry as the cube. Although their forms are so different, both crystals are 'cubic.' Any actual crystal will not form perfectly symmetrical solid figures, for accidents of growth will cause irregularities. Some faces of the octahedron will be larger than others, but because these octahedron faces are a result of the underlying cubic structure of the crystal, they will still make

the same angles with each other, and so be recognisable.

Any elements of symmetry possessed by the lattice are also possessed by the crystal. A space lattice such as that on which we have supposed the atoms to be arranged has an infinite set of axes, planes, and centres of symmetry, all of which are, so to speak, embodied in the structure. For instance, the lattice has axes of fourfold symmetry, coinciding with all the cube edges in Fig. 17 (a) (b) (c), and also parallel axes of fourfold symmetry passing through the cube centres. The crystal has therefore three axes of fourfold symmetry at right angles to each other, parallel to the three cube edges. In the same way it has four threefold axes perpendicular to the planes $\{111\}$, three planes of symmetry parallel to the cube faces $\{100\}$, six planes of symmetry $\{110\}$, and six twofold axes perpendicular to these planes. Since there is a centre of symmetry at each cube corner and cube centre of the lattice, the crystal has also a centre of symmetry. Each kind of axis in the structure corresponds to an axis of the crystal.

It is these true elements of symmetry of a crystal which are important, and not mere accidents of form. By the symmetry they possess crystals are classified, in the first place into six families or systems, and afterwards by further subdivision into thirty-two classes. A detailed account of the classes would be out of place here, but a list is given of the features which distinguish the six systems. The definitions are based upon those in Miers' *Mineralogy*:

Cubic System. Crystals referable to three equal rectangular axes. All crystals of this system possess four trigonal axes.

Tetragonal System. Crystals referable to three rectangular axes, two of which are equal, the third being a tetragonal axis.

Orthorhombic System. Crystals referable to three unequal rectangular axes, one of which is a digonal axis. This axis has either two planes of symmetry intersecting it, or two digonal axes perpendicular to it.

Hexagonal System. Crystals referable to three equal oblique axes, and possessing one trigonal or hexagonal axis.

Monoclinic System. Crystals referable to three unequal axes, one of which is perpendicular to the other two, and possessing either one digonal axis or one symmetry plane.

Anorthic System. Crystals referable to three unequal oblique axes and possessing at the most a centre of symmetry.

In the further subdivision, each class has its own characteristic symmetry. Now the three space lattices of Fig. 17, which belong to the cubic system, all have the same elements of symmetry, *i.e.* the full number which the cubic system can possess. By themselves they furnish no criterion of the particular class to which the crystal belongs. It is the arrangement of atoms around each of these points which now enters into consideration, and the symmetry of

the structure as a whole may be modified by the symmetry of each little unit of the pattern.

A two dimensional model will serve to show how this comes about.

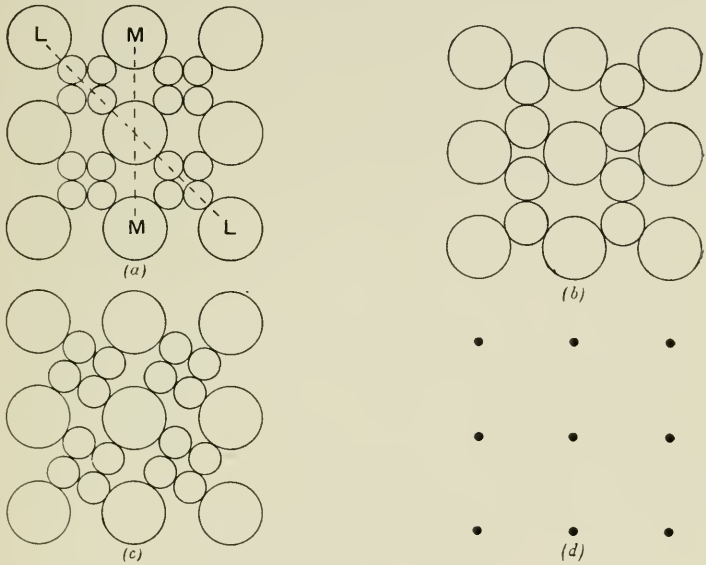

FIG. 19.

Fig. 19 (a) is supposed to be part of a crystal in two dimensions with tetragonal axis perpendicular to the plane of the paper. The structure is also symmetrical about such lines as LL , MM . The crystal is built up on the space lattice (d), which possesses the same elements of symmetry, and may be called the typical lattice of the 'square' system in two dimensions. In Fig. 19 (c) we have another crystal built up on the same lattice, and therefore belonging to the same system. Here the groups of

four small atoms are supposed to have slightly slewed round for some reason connected with their equilibrium. It is obvious that this crystal is no longer symmetrical about any line; it has lost certain elements of symmetry which (*a*) possesses. The crystals belong to two different 'classes' of the four-fold 'system,' the class to which (*a*) belongs being characterised by fourfold axes, and lines of symmetry parallel to *L* and *M*, while the class to which (*c*) belongs has only the fourfold axes. The two dimensional square crystals can in this way be divided into two kinds, those which possess 'lines' of symmetry and those which do not. We have subdivided the 'square' system into two classes, the foundation of the structure in both cases being the same 'square plane-lattice.' It might be argued that still other classes of crystals could be built up on this same square lattice, Fig. 19 (*d*) being an example. But in this figure the arrangement of the structure makes it clear that if the lattice is a square one, it is so merely by coincidence. It would be natural for the vertical and horizontal dimensions in the figure to be different. In the other cases the structure provides a reason for the equality of the two rectangular axes. Considerations of this kind show that there are only two classes in this category.

These considerations may be carried over to the three-dimensional case. The three cubic space lattices provide a basis, on which crystals are built up which possess some, but not all, of the elements of symmetry possessed by the space lattices. They

are classified according to their symmetry, the cubic system being divided into five classes, just as the 'square' system in two dimensions is divided into two classes. The tetragonal system is divided into seven classes, the hexagonal into twelve classes, and so on, the whole number of classes being thirty-two.

The results obtained with the X-ray spectrometer enable us to discover both the space lattice on which the atoms are arranged and the way in which they are grouped round each point of the space lattice. Several of the cases which we shall presently discuss provide very clear illustration of the manner in which the symmetry of the group determines the symmetry of the crystal as a whole. As in Fig. 19 (*c*), the groups of atoms are so arranged as to limit the number of elements of symmetry, while retaining sufficient to cause the structure to be cubic. This arrangement of the atoms has been so long a mere matter of speculation that it is interesting to find actual examples now within our grasp.

CHAPTER VI.

X-RAY SPECTRA.

WE now proceed to enquire what information the new methods give us in respect to the composition of the heterogeneous radiation issuing from the X-ray bulb. As has been said already, a substance can be stimulated to the emission of its characteristic X-rays by bombarding it with cathode rays of sufficient velocity. Consequently we may expect that the substance of the bombarded anticathode will contribute its characteristic rays to the general stream. This is found to be the case; the spectrometer analyses the radiation into a more or less continuous spectrum, from which certain homogeneous pencils of definite wave length stand out with greater or less clearness. Possibly the continuous part of the spectrum may eventually be resolved into separate 'lines'; but so far, at any rate, this has not been done.

The earliest measurements which were made with the spectrometer practically constituted an analysis of this kind. The curves of Fig. 20, taken from the original paper, show the variation of the intensity with the magnitude of the glancing angle

of reflection. The bulb was of the usual kind, having a platinum anticathode; it was therefore natural to suppose that these special rays might constitute the characteristic radiation of platinum. This was confirmed by various tests. It is worth while to consider the nature of these tests and the degree to which they were satisfied.

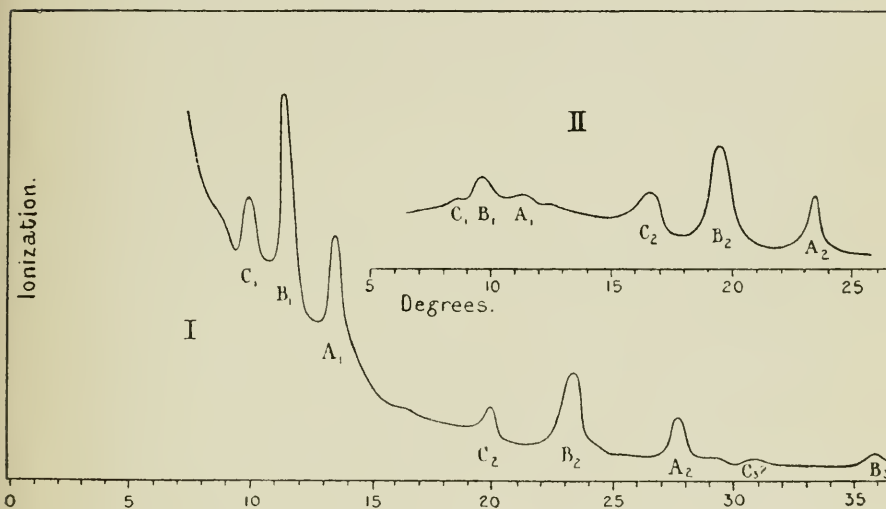

FIG. 20.

I. Rock salt (100), II. Rock salt (111).

In the first place, it was necessary to show that the special rays were characteristic of the anticathode and not of the crystal. This was readily done by varying first the one and then the other of the two possible sources. When the crystal was changed, and iron pyrites, potassium ferrocyanide, fluorspar, sodium ammonium tartrate and other crystals were used in turn, the same set of peaks

occurred at the same points of the reflection curve and of the same relative magnitude (see, however, p. 185). Only the general scale of the reflection seemed to depend on the nature of the crystal.

When, however, the bulb was changed, and a different substance was used as anticathode, the spectrum altered entirely. A tungsten bulb gave a weak line at a glancing angle in rock salt of 12.9° .^{*} It was not a good bulb, and, as we know now, the tungsten spectrum resembles the platinum spectrum, so that the line observed was only the strongest of a series. Another bulb was constructed with a nickel anticathode, which gave a line at 17.2° .

These experiments made it perfectly clear that the special rays were characteristic of the anticathode and not of the crystal.

In the next place, it was necessary to discover whether the rays were actually the characteristic rays of Barkla: though indeed there could be little doubt upon the point. Barkla defined his rays in terms of their absorption coefficients (p. 43) by various substances, and especially by aluminium. An examination of the absorption of the strongest set of special rays of the platinum bulb (Fig. 20, *B* peak) showed that the coefficient of absorption in aluminium was nearly 24, and that the rays were homogeneous, because the coefficient did not vary with the thickness of the screen. Barkla has given 27.5 as the value of the absorption coefficient found in the usual way (p. 42). The agreement was quite satisfactory.

^{*} *Proc. Roy. Soc.* 89, p. 247.

Moreover, the absorption coefficient of the same rays by various other metal sheets, silver, copper, nickel and others, were all of the right magnitude.*

It was therefore clear that the observed effects might properly be described as the spectra of the characteristic X-radiations.

The recurrence of three similar but smaller peaks at twice the angles of the first (more strictly, at twice the sines of the angles) was clearly in accordance with the analysis already given (p. 17). Homogeneous radiations of wave length λ should undergo reflection by crystal planes of spacing d at angles θ derived from the equation $n\lambda = 2d \sin \theta$ by giving n successive integral values. The peaks $A_2B_2C_2$ constituted the second order reflection of the rays, the glancing angles of reflection being obtained by putting n equal to 2. Traces of a third order, B_3, C_3 , were also to be seen. Also, if the crystal was cut so as to show a (111) face, the three peaks occurred at angles which differed from the (100) angles, but were in accordance with the theory. The (111) spacing of a cubic crystal bears to the (100) spacing a ratio which contains $\sqrt{3}$ as a factor (p. 92): it may, for example, be $\sqrt{3}/2$ or $\sqrt{3}/4$. The angle of the strongest reflection of the B peak in the (111) face was $20^\circ 6'$: the angle of reflection in the (100) face was $11^\circ 33'$. The sines of these angles are 0.344 and 0.200, and are very nearly in the ratio $\sqrt{3}$ to 1.

* *Proc. Roy. Soc.* 88, p. 434.

These and other coincidences between calculation and experiment showed that the characteristic X-radiations consisted of sets of homogeneous rays. Previous methods of analysis which had relied on distinction by means of absorption coefficients had naturally been unable to resolve the characteristic radiation of each substance into its separate constituents. It was now clear that the characteristic rays of each substance consisted, not of a single homogeneous constituent, but of a group of such constituents. The precision with which each member could be defined showed that each homogeneous ray contained, on issuing from the bulb, a long train of waves, and possessed a wave length capable of exact definition.

As soon as a satisfactory determination had been made of the structure of some one crystal—it was first accomplished in the case of the rock salt series (p. 94)—absolute measurements of wave length became possible.

This opened the way to another and very different opportunity of comparing the experimental results with the anticipations of modern theories of radiation.

Under the close and yet widely-ranging scrutiny which modern experimental methods have rendered possible, the older radiation theories have been found wanting in certain respects; for example, in their ability to explain the variations of specific heat constants with temperature. One of the best known and most brilliant of the attempts to improve them

has been made by Planck. His hypothesis is not so much an attempt to explain, as a focussing of all the difficulties into one: so that, if this master difficulty is overcome, a number of others melt away. The fundamental idea is that a vibrator which can emit ether waves can only do so in such a way that the quantity of energy given out is an exact multiple of a certain unit or 'quantum.' The number of vibrations per second, or frequency, being denoted by ν , the unit belonging to any frequency is $h\nu$, where $h = 6.55 \times 10^{-27}$, and is called 'Planck's constant.' The magnitude of the unit changes, therefore, from frequency to frequency; but h is a constant of nature. No explanation is suggested as to how this effect occurs: we are not as yet able to form any conception of the mechanism. The only demand made by the hypothesis is that the interchange of energies in the processes of radiation is carried out in this curious discontinuous manner.

As soon as the wave length of the X-ray became a measurable quantity, the magnitude of the corresponding quantum could be calculated. For example, the *B* peak of the platinum curve was deflected by rock salt at a glancing angle of 11.3° : and the spacing of the planes was 2.81×10^{-8} cm. (see p. 110). The wave length was therefore

$$2d \sin \theta = 2 \times 2.81 \times 10^{-8} \times 0.196 = 1.10 \times 10^{-8}.$$

The frequency was obtained by dividing the velocity of light by the wave length, and consequently the quantum energy was equal to

$$6.55 \times 10^{-27} \times 3 \times 10^{10} / 1.10 \times 10^{-8} = 1.78 \times 10^{-8} \text{ ergs.}$$

In the same way the quantum energy of the nickel ray, reflected at 17.2° , was 1.18×10^{-8} ergs.

According, therefore, to Planck's hypothesis, X-radiation of the two qualities can be emitted only in multiples of the corresponding quanta. Now we are fortunate enough to possess certain information as to the relation between the quality of the X-ray and the amount of energy concerned in its production and absorption. Whiddington has shown* that an electron forming part of the cathode-ray stream must possess a certain velocity if it is to excite the X-ray characteristic of the anticathode upon which it falls. In the case of nickel he found the critical velocity to be

$$6.17 \times 10^9 \text{ cm./sec.},$$

or about one-fifth of the velocity of light. He made no direct measurement of the critical velocity in the case of platinum; but as the 'B' peak of platinum represents a radiation whose absorption coefficient is about 24, and the same, therefore, as would be emitted in the *K* series (p. 42) by an atom of weight equal to 70 approximately, we may assume the critical velocity to be that of the latter atom, and this, according to Whiddington's measurements, is about 7×10^9 cm./sec. Taking the mass of the electron as 0.9×10^{-27} , we can easily calculate that the energy of the cathode ray is 1.7×10^{-8} ergs in the former case and 2.2×10^{-8} ergs in the latter.

In this way we know roughly the amount of energy which the cathode ray must possess if it is to

* *Proc. Camb. Phil. Soc.* 1910.

excite the corresponding X-ray. We know something also of the energy changes in the converse process, because experiment shows that the cathode ray, which is excited by the X-ray, has an energy of movement approximately equal to that of the cathode ray by which the X-ray was excited. We are justified in assuming that these processes are actual examples of the give and take of radiant energy with which Planck's hypothesis is concerned. We may compare the experimental value of the energy required to excite the nickel X-ray, viz. 1.7×10^{-8} ergs, with the quantum energy deduced from the wave length of the nickel ray, viz. 1.18×10^{-8} ergs: * and so also we may compare the corresponding quantities in the case of the platinum ray, 2.2×10^{-8} and 1.78×10^{-8} . Though the agreements are not exact, they are wonderfully close, considering all the circumstances of the case.

The experiment of Whiddington afforded a further opportunity of comparison. He was able to derive from his results a general law, that the critical velocity required to excite the ray characteristic of any atom was approximately proportional to the weight of that atom; it was, in fact, nearly equal to the atomic weight multiplied by 10^8 . The law was confined to the *K* series of radiations (p. 42). Coupling this statement with the fundamental idea of Planck's hypothesis, it could be argued that the frequency of a characteristic X-ray, being

* Nickel emits also a shorter wave (see p. 74), for which the quantum energy is 1.3×10^{-8} ergs.

proportional to the energy of the cathode ray required to excite it, should therefore be proportional to the square of the weight of the corresponding atom.

This deduction was of immediate practical benefit to the course of the experiments. In examining the reflections from various crystals in order to determine their structure, it had become clear that a bulb emitting a wave length about half that given by the principal radiation of platinum would be of material assistance. Since the platinum ray was such as would be emitted—in the *K* series—by an atom of weight about 70, the atom to give the desired radiation should have a weight of $70\sqrt{2}$ or 100. Rhodium—atomic weight 102.9—was therefore chosen as a suitable substance for the anticathode. The result agreed with expectation. The rhodium bulb was found to emit two strong rays of wave lengths 0.607×10^{-8} and 0.533×10^{-8} cm., the former being much more intense than the latter: and it was an unexpected piece of good fortune that the general radiation was comparatively weak. A bulb with a palladium anticathode was found to give a spectrum of exactly similar character, the two wave lengths being 0.576×10^{-8} and 0.507×10^{-8} . The similarity of these two spectra led to a re-examination of the spectra of the nickel bulb, and of a copper bulb which had also been constructed. It was then found that the nickel bulb had a second line which had been overlooked previously, and that the copper anticathode also emitted a two-line spectrum. In

all four cases the relative separation of the two lines was the same.*

The examination of the platinum spectrum was also carried out by Moseley and Darwin.† By using finer slits (0.5 mm. broad) and by increasing the distances from the crystal to the source of rays, and to the ionisation chamber, they were able to improve very greatly the accuracy of the angular measurements. In order to compensate for the reduction in intensity which accompanied these changes, they employed a method of multiplying the ionisation current which had been previously used by Griffith and by Rutherford and Geiger. They showed that the two peaks which we have hitherto called *B* and *C* were in reality close doublets, and they gave the following values of the glancing angles of the rays (now five) of platinum :

$9^{\circ}28'$, $9^{\circ}47'$, $11^{\circ}17'$, $11^{\circ}28'$, and $13^{\circ}31'$.

They estimated that these values were correct to one minute of arc. The crystal face was rock salt (100). They also measured the relative intensity of the general radiation in different parts of the spectrum.

Moseley afterwards undertook a systematic investigation of the spectra emitted by all the known elements which could be brought under examination. The results are given in two papers published in the *Philosophical Magazine* for December, 1913, and April, 1914. They constitute a most remarkable and important contribution to the subject.

* Second Solvay Congress (October, 1913). † *Phil. Mag.* July, 1913.

The experimental difficulties in the case of some of the substances examined were very considerable. In order to absorb the rays emitted by the various anticathodes as little as possible, the X-ray bulb

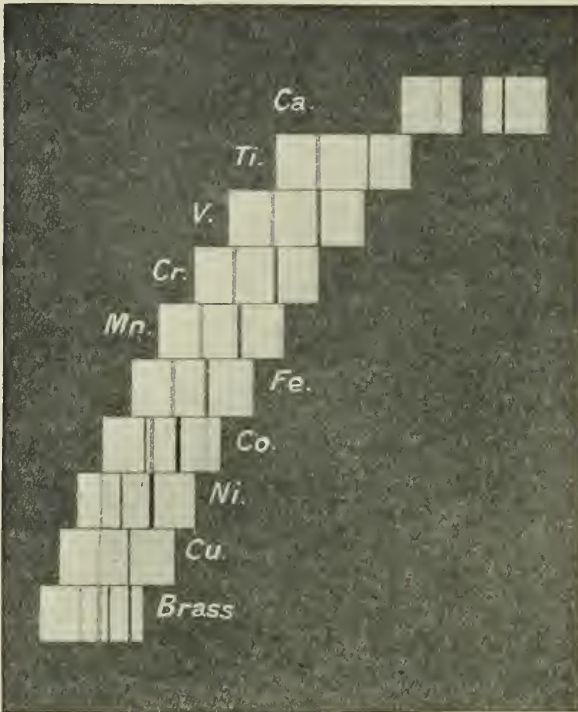

FIG. 21.

was provided with a thin aluminium window, through which the rays passed on their way to the crystal, and thence to the photographic plate which registered them. Some substances emitted rays so soft that goldbeater's skin had of necessity to be substi-

tuted for the aluminium ; and, in addition, the whole spectroscope had to be enclosed in an evacuated chamber, since the rays could not penetrate a few centimetres of air. Others, such as calcium, could only be submitted to the rays for very short periods, because they gave off gas which lowered the vacuum. Certain substances could only be examined in alloy with others, or as chemical compounds, such as oxides.

A number of the photographic results obtained by Moseley are illustrated in Fig. 21, which is taken from his earlier paper. The figure displays the spectra of the characteristic radiations of certain metals, ranging from calcium to zinc, the latter having been investigated as a constituent of brass. The separate photographs are so arranged as to show a gradual increase in wave length, which goes with a decrease in atomic weight. Brass shows the spectra of both copper and zinc, and the cobalt evidently contains both iron and nickel. The double-line spectrum already alluded to is clearly characteristic of all these substances.

The next figures (Figs. 22 and 23) are re-drawn from Moseley's second paper, and exhibit the results described in both papers in a most convenient and instructive form. One or two minor alterations have been made on the basis of information very kindly supplied to us by Mr. Moseley himself. The first point to which reference must be made is the choice of the method of distinguishing the atoms. The ordinates are not, as might have

been expected, the atomic weights, but the *atomic numbers*—numbers, that is to say, which represent the order of the atoms in the periodic table. It has already been argued, for example, by Van den

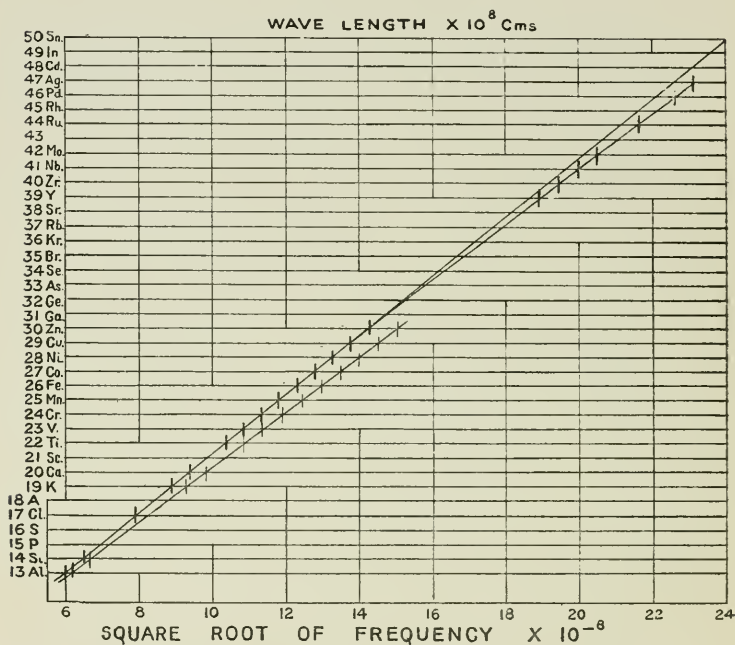

FIG. 22.

Broek,* that the number indicating the order of the element in the periodic table is a more fundamental index of quality than the atomic weight. Van den Broek has also pointed out that the number does not generally differ much from the half of the atomic weight.

* *Phys. Zeit.* 1913, p. 82.

The abscissae in the figure are the square roots of the frequencies, which we should expect to find (see above) to be proportional approximately to the atomic weights, and therefore to the atomic numbers.

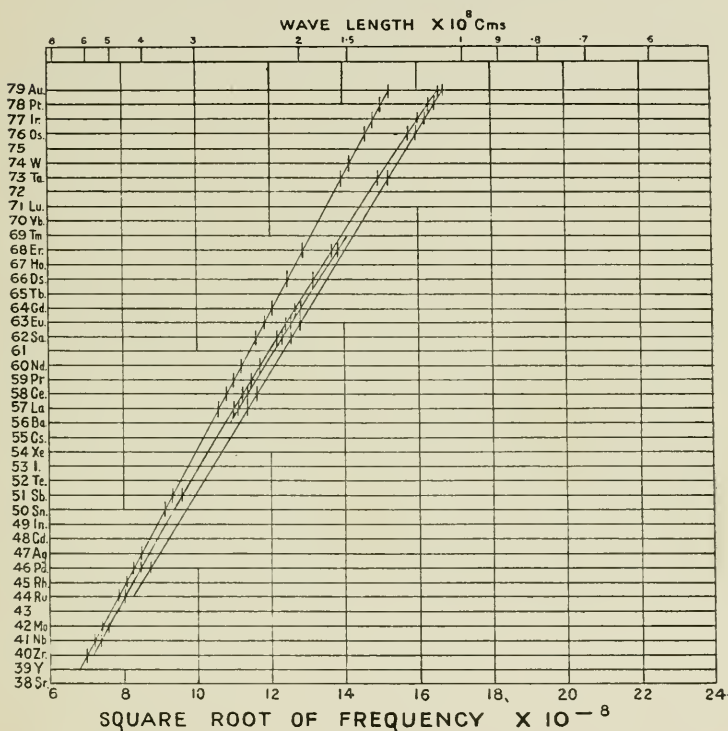

FIG. 23.

The figure shows that the radiations characteristic of the various elements belong to one or other of two sequences, which clearly correspond to the *K* and *L* series of Barkla. Considering first the former of the two, we find that points representing the wave

lengths observed lie on an exceedingly good line, which is almost straight. The order chosen for the elements is the order of the atomic weights, except in the cases of argon and cobalt, where this clashes with the order of the chemical properties. This is

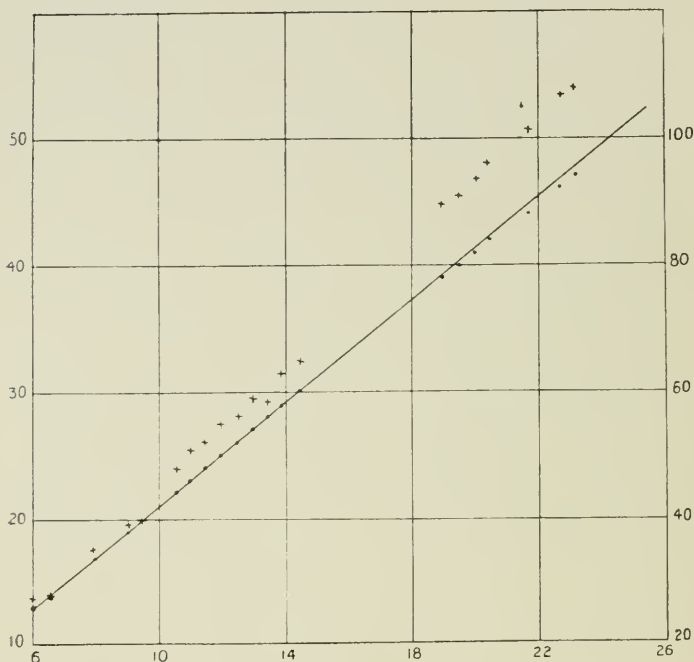

FIG. 24.

Crosses, frequency and atomic weight, figures on the right.
Dots, " " " " number, " " left.

equivalent to assigning to successive elements a series of successive characteristic integers. How much more closely the wave lengths march with a series of natural numbers than with the atomic weights is shown in Fig. 24, in which the two sets

of points, plotted from Moseley's figures, show the relation between frequency and number, frequency and weight respectively. It will be observed that no element is missing from the series of Figs. 22 and 23, nor are there any vacant places, so far as the K series is concerned, except between molybdenum and ruthenium. The absence of a number of indicating points implies merely that the corresponding elements have not been examined.

The relations of the L radiations to the atomic number are of the same character. Tellurium is placed in accordance with its chemical properties rather than its atomic weight, and spaces have been necessarily left for three new elements, one between neodymium and samarium, one between lutecium and tantalum, and one between tungsten and osmium.

The atomic number which is brought into such prominence by these experiments must be something more than a mere ordinal: it must represent some fundamental attribute of the atom.

Now it has been shown by Rutherford* that the deflections from the rectilinear path which are occasionally experienced when the α particle passes through an atom are of such magnitude and frequency as can be accounted for only by supposing a positive nucleus to be placed at the atom centre. Experiments carried out by Rutherford and Geiger showed that the magnitude of the nuclear charge was Ne , where e is the charge of the electron and N a number approximately equal to half the atomic

* *Phil. Mag.* 1911, p. 669.

weight. It is therefore (see above) nearly equal to the atomic number. It is a very natural hypothesis which suggests that the atoms vary by successive accretions of e to their nuclear charges. The relations between X-rays and atoms are known to be very fundamental; since, for example, the absorption of X-rays by various substances is totally independent of physical state and chemical combination. We may well suppose that the wave length of the characteristic ray depends directly on the magnitude of the nuclear charge, and that, in fact, the frequency increases steadily with it.

Moseley has pushed still further the comparison of his experimental results with modern theory. A very remarkable and ingenious hypothesis has lately been advanced by N. Bohr,* in which he defines more closely than hitherto the circumstances under which the exchanges of energy between wave motion and electron take place. His theory leads to a formula for the frequency of which the following is a very simple form :

$$\nu = \frac{2\pi^2 m e^2 E^2}{h^3} \left(\frac{1}{\tau_2^2} - \frac{1}{\tau_1^2} \right)$$

where

e = charge of an electron,

m = mass ,, ,,

E = nuclear charge,

h = Planck's constant,

τ_1 and τ_2 are whole numbers.

In the case of hydrogen the nuclear charge $E = e$,

* *Phil. Mag.* July, September, November, 1913.

for the nucleus contains only a single charge. Referring to this case, Bohr says :

‘ We see that this expression accounts for the law connecting the lines in the spectrum of hydrogen. If we put $\tau_2 = 2$ and let τ_1 vary we get the ordinary Balmer series. If we put $\tau_2 = 3$, we get the series in the infra-red discovered by Paschen, and previously suspected by Ritz. If we put

$$\tau_2 = 1, \text{ and } \tau_2 = 4, 5, \dots$$

we get series respectively in the extreme ultra-violet and the extreme ultra-red which are not observed, but the existence of which may be suspected.

‘ The agreement in question is quantitative as well as qualitative. Putting

$$e = 4.7 \times 10^{-10}, \quad e/m = 5.31 \times 10^{17} \quad \text{and} \quad h = 6.5 \times 10^{-27}$$

we get

$$\frac{2\pi^2 m e^4}{h^3} = 3.1 \times 10^{15}.$$

The observed value for the factor outside the bracket in the formula (*i.e.* $2\pi^2 m e^4 / h^3$) is 3.290×10^{15} .

If, as Bohr suggests, we put $\tau_2 = 1$, and give τ_1 the value 2—we remember that τ_1 may have any integral value, and 2 is the smallest which gives a frequency having any meaning—and if we give E the value Ne where N is the atomic number we actually find that the frequency given by the formula is that of the strong line in the two-line X-ray spectrum of the substances which lie between aluminium and silver.

For example, in the case of palladium, $N = 46$.

Hence

$$\begin{aligned} \nu &= \frac{2\pi^2 m e^4}{h^3} \cdot N^2 \left(\frac{1}{1^2} - \frac{1}{2^2} \right) \\ &= 3.290 \times 10^{15} \times 46^2 \times 3/4, \\ &= 5.21 \times 10^{18}. \end{aligned}$$

The corresponding wave length is therefore

$$\begin{aligned} &3 \times 10^{10} / 5.21 \times 10^{18} \\ &= 0.576 \times 10^{-8}, \end{aligned}$$

which agrees with the experimental value (p. 74). As a matter of fact, it is exactly the same, but we can only consider that to be accidental. The wave length for copper calculated in the same way is 1.45×10^{-8} and the experimental value is 1.55×10^{-8} . Moseley gives an interesting explanation of the small divergence between theory and experiment.

We ought perhaps to refrain from further discussion of these remarkable arguments, for they are still under debate. The reader may be referred to the original papers.

The photographic registration of spectra has also been carried out by de Broglie,* who was indeed the first to publish results obtained by this method. He uses the method of the uniformly revolving crystal which has already been described, a method which has the advantage of dealing with a wide range of wave lengths at one time. Herweg has also obtained spectra by the photographic method,† his results agreeing with those found by the ionisation method.

* *C.R.* Nov. 1913, etc.

† *Verh. d. D. Phys. Ges.* Jan. 1914.

Rutherford and Andrade have used the revolving crystal method for the determination of the wave lengths of γ -rays.* They have shown that the γ -ray spectrum of radium *B* is of the same general type as that found for platinum and other metals of large atomic weight. Moreover, they have found evidence that the spectrum of the soft γ -rays spontaneously emitted from radium *B* is identical within the limits of experimental error with the spectrum given by lead when the 'L' characteristic radiation is excited by the bombardment of β -rays.

The extreme interest of this discovery lies in the fact that it is in agreement with a remarkable theory, in support of which Fajans and Soddy have lately contributed much strong evidence. It is possible to point to certain groups of substances, at least among the radio-elements, which must be considered to occupy the same place in the periodic table, and yet to differ somewhat in atomic weight. Soddy has pointed out that radium *B*, actinium *B*, thorium *B*, and radium *D* are all 'isotopes' of lead, showing chemical properties identical with those of lead, and inseparable from lead by chemical means. This is in spite of the fact that their atomic weights differ from each other; that of radium *B* is 214 nearly, of radium *D* 210, of thorium *B* 212 and of lead 207.1. That which is common to them all is—adopting Rutherford's idea as to the structure of the atom—the positive nuclear charge. Considering the close relation which, following the same theory, is sup-

* *Phil. Mag.* 1914.

posed to exist between the wave length of the X-ray and the nuclear charge, it is to be expected that isotopes should yield the same X-ray spectrum. The fact that they are now found to do so is a striking confirmation of theory. The wave lengths which they emit belong to the *L* series of Barkla.

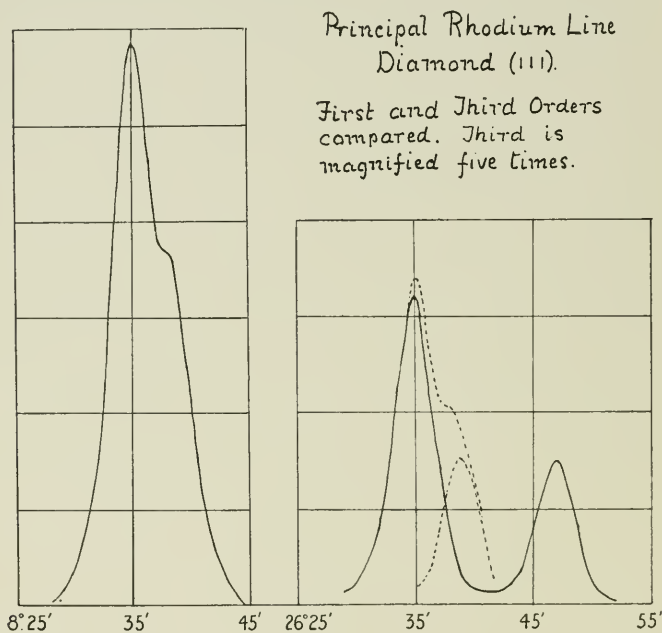

FIG. 25.

It is to be observed, however, that in all these comparisons we have picked out the important lines from the various spectra, and we are still in ignorance as to how to place the rest. We do not understand in the least the mechanism through which it is brought about that so many of the elements

emit two-line spectra, and that in others there is a still more complex arrangement of five lines at least. Even the principal line of the two-line spectrum is really a very close doublet: the wave lengths of the rhodium doublet being, for example, 0.614×10^{-8} and 0.619×10^{-8} . We are not yet able to give any explanation whatever of these departures from simplicity.

The double nature of the rhodium line is well shown in the foregoing figure (Fig. 25), which compares the first and third order reflections in the cleavage plane of the diamond. In the first order the double nature is indicated only, but in the third the doublet is completely resolved. The treble separation in the third order shows that the effect is real. It is not due for example to irregularities of the crystal or of the source of rays.

CHAPTER VII.

THE ANALYSIS OF CRYSTAL STRUCTURE. PT. I.

THERE are three types of faces which are more frequently developed on cubic crystals than any others. If a crystal grows regularly with faces of one of these types, it becomes a cube, a rhombic dodecahedron or an octahedron, according as to whether the faces have indices of the form $\{100\}$, $\{110\}$ or $\{111\}$. Faces with more complicated indices are comparatively uncommon on cubic crystals, and in making an examination of the crystal with the X-ray spectrometer, these simple faces are naturally the first to be investigated.

Fig. 26 shows the results of the examination of two cubic crystals. These are potassium and sodium chloride, whose very strong resemblance to each other suggests that the crystals are built up in the same way. They are two examples of a series of cubic crystals believed to be isomorphous, which have the composition RX , R being one of the alkaline metals lithium, sodium, potassium, rubidium, caesium, and X one of the haloids fluorine, chloride, bromine and iodine.

It is clear that the spectra given by corresponding

faces of the two crystals strongly resemble each other.

Moreover, we can in the following way institute a quantitative and a closer comparison, which brings out the identity of the structure.



FIG. 26.

For each face the wave length and the spacing of the crystal planes parallel to that face are connected by the equation

$$n\lambda = 2d \sin \theta.$$

90 ANALYSIS OF CRYSTAL STRUCTURE

Consider the first reflection from the faces (100) in each case.

$$\text{We have } 2d_1 \sin \frac{10.43^\circ}{2} = \lambda,$$

$$2d_2 \sin \frac{11.8^\circ}{2} = \lambda,$$

giving us $d_1 = 5.48\lambda,$

$$d_2 = 4.85\lambda,$$

where d_1, d_2 are the spacings for NaCl and KCl respectively, and are therefore proportional to the dimensions of the atomic structure in each case.

Though the two structures are similar, they have not the same dimensions. The potassium chloride crystal is built on a larger scale than the sodium chloride crystal, or, to put it in another way, the molecule of potassium chloride occupies more volume than the molecule of sodium chloride. The ratio of these volumes is the ratio of the molecular volumes of the two crystals, the molecular volume being the molecular weight divided by the specific gravity. Potassium chloride should have a larger molecule volume, according to the relation :

$$\frac{d_1^3}{d_2^3} = \frac{\text{Molecular volume of KCl}}{\text{Molecular volume of NaCl}} = \frac{M_1/\rho_1}{M_2/\rho_2},$$

where M_1, M_2 are the molecular weights, ρ_1 and ρ_2 the densities, of the two crystals. Or we may say

that the quantity $d\sqrt[3]{\frac{\rho}{M}}$ should be the same for these two crystals and for other members of the same series.

Testing this, we find :

$$\begin{aligned} \text{for KCl} \quad d\sqrt{\frac{\rho}{M}} &= 1.63\lambda, \\ \text{NaCl} \quad \text{,,} &= 1.62\lambda, \\ \text{KBr}^* \quad \text{,,} &= 1.63\lambda. \end{aligned}$$

So far the results merely indicate that the structure of KCl and NaCl are analogous. Now

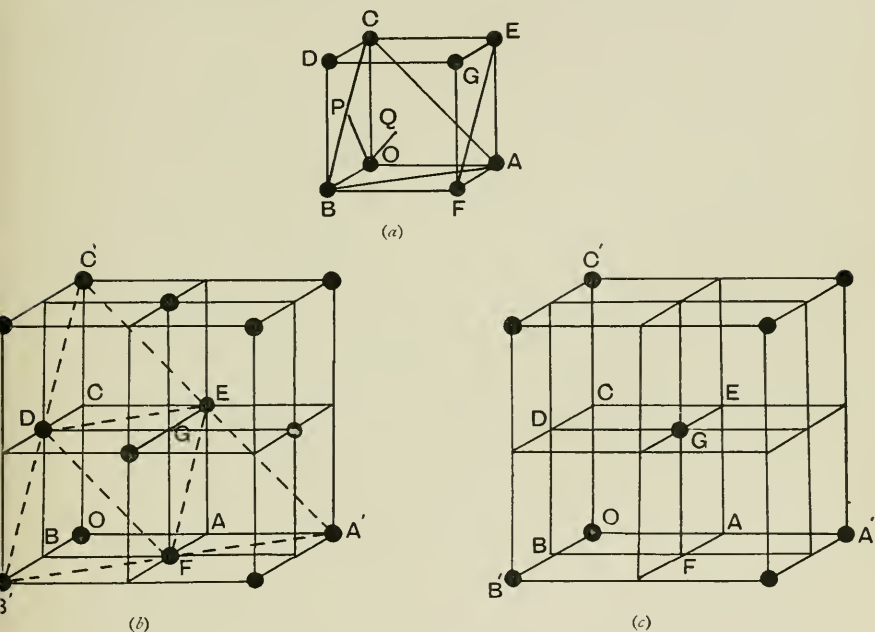

FIG. 27.

let us examine the relations which exist for the three faces of the same crystal, potassium chloride.

Let $OBFACDGE$, Fig. 27 (a), be a cube of the KCl structure. Imagine for the moment that it is

* KBr being yet another crystal of the same series.

92 ANALYSIS OF CRYSTAL STRUCTURE

replaced by a simple cubic space lattice, a point being at each of the cube corners. The planes (100) are parallel to $OBDC$, and their distance apart is equal to OA . The planes (110) are parallel to $CBFE$, their distance apart being OP . The planes (111) are parallel to ABC , and their distance apart is equal to OQ , the perpendicular from O on ABC .

For this simple cubic space lattice, we have the relation

$$\frac{1}{d_{(100)}} : \frac{1}{d_{(110)}} : \frac{1}{d_{(111)}} = \frac{1}{OA} : \frac{1}{OP} : \frac{1}{OQ} \\ = 1 : \sqrt{2} : \sqrt{3}.$$

Turning now to the potassium chloride measurements, experiment shows that for the crystal itself

$$\frac{1}{d_{(100)}} : \frac{1}{d_{(110)}} : \frac{1}{d_{(111)}} = \sin 5.22^\circ : \sin 7.30^\circ : \sin 9.05^\circ \\ = .0910 : .1272 : .1570 \\ = 1 : 1.40 : 1.74 \\ = 1 : \sqrt{2} : \sqrt{3}$$

agreeing with the measurements for the cubic lattice above.

Suppose that instead of a simple cubic lattice, the arrangement were that of the face-centred lattice as in Fig. 27 (b). As compared with (a) we have drawn the cube on twice the scale for a reason which will appear presently. The distances $d_{(100)}$ and $d_{(110)}$ are equal to those in Fig. 27 (a), but the distance $d_{(111)}$ is twice as great as before. As compared with (a) (b) has a (111) plane passing through O , and then one passing through DEF ,

the ABC plane being missing. $d_{(111)}$ is now the perpendicular from O on $A'B'C'$. For Fig. 27 (*c*), the cube-centred lattice, $d_{(100)}$ and $d_{(111)}$ are the same as for the simple cubic lattice,* but $d_{(110)}$ is now twice as great as before. Comparing the spacings of these three lattices we have :

Cube-lattice	$\frac{1}{d_{(100)}} : \frac{1}{d_{(110)}} : \frac{1}{d_{(111)}} :: 1 : \sqrt{2} : \sqrt{3}.$
Cube-centred lattice	,, ,, :: $1 : \frac{1}{\sqrt{2}} : \sqrt{3}.$
Face centred cube lattice	,, ,, :: $1 : \sqrt{2} : \frac{\sqrt{3}}{2}.$

Our measurements on KCl therefore tell us something definite about its structure. It is the cube lattice to which it is analogous, as against the other two.

Turning to the NaCl spectra, it is at first sight puzzling to say to which lattice the structure is to be referred. One spectrum, that from the (111) plane, is of a new type. It has a weak first reflection, a strong second one, a very weak third, a perceptible fourth. The potassium chloride spectra do not show such irregularities; in the case of all three planes the spectra diminish regularly in intensity as one passes to reflections of a higher order. Judging by the strong reflections, we would assign to NaCl a simple cube lattice like that of KCl, but judging by the positions of the reflection of the first order, we would assign to it a face-centred lattice such as that of Fig. 27 (*b*).

* To see this, imagine the lattice to be extended in all directions.

94 ANALYSIS OF CRYSTAL STRUCTURE

The dissimilarity between KCl and NaCl suggests that the diffracting centres, which seem to be arranged on a cube lattice in KCl, are not molecules, for if they were there is no reason why the similar structure NaCl should not also give spectra characteristic of a cube lattice. It is found that of the series NaCl, KCl, KBr, KI, it is only KCl which gives these simple spectra. When we remember further that the efficiency of an atom as a scatterer of X-rays is supposed to be proportional to its atomic weight, a simple reason suggests itself for the special behaviour of KCl. Potassium and chlorine atoms have nearly equal masses, and so act as identical diffracting centres. In this way we are led to suppose that this series has a structure as represented in Fig. 28A.

The two kinds of particles represent atoms of metal (K or Na) and halogen (Cl, Br, I). Considering the points of one kind alone, the whites for example, it is clear that they lie on a face-centred lattice, such as is hinted at by the spectra of rock salt. If the atoms are identical as regards their behaviour to X-rays, the structure reduces to a straightforward cubic one.

The arrangement of the atoms in planes is shown diagrammatically by Fig. 28B. The planes (100) contain atoms of both kinds. As we are going to compare KCl and NaCl, let us call the metal R. We can then denote the constitution of the (100) planes in both cases by saying they contain R.Cl. The (110) planes are built up in the same way, but

their distance apart is smaller in the ratio $1:\sqrt{2}$. The (111) planes are of a different nature, however. The successive planes contain R atoms alone and Cl atoms alone alternately.

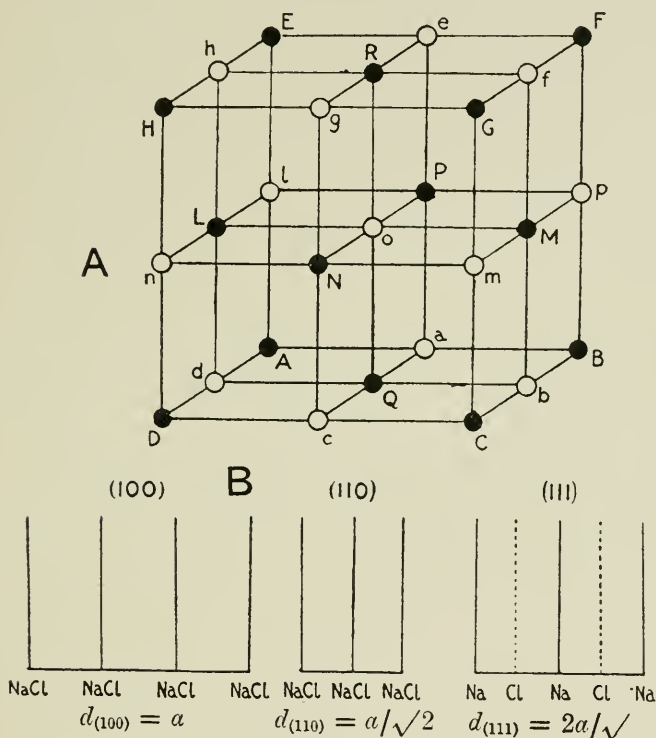

FIG. 28.

If we reflect the X-rays from the planes (111) in Fig. 28B, the true distance $d_{(111)}$ is that from like plane to like. The angle of the first reflection is given by the equation $\lambda = 2d_{(111)} \sin \theta$. But halfway between the planes of composition Cl are spaced

planes of composition R. These reflect waves which are, for the first reflection, just out of step with (*i.e.* in opposite phase to) the waves reflected from the Cl planes. Their effect is to tend to destroy the first reflection, and in fact every reflection of the odd order, while they strengthen the reflections of even order. This effect is apparent in the spectrum of (111) NaCl, where the planes containing sodium of atomic weight 23 alternate with the planes containing chlorine of atomic weight 35.5. In $\text{KCl}_{(111)}$ the atomic weights (39 and 35.5) are so close that the spectra of odd order are absolutely cut out. The crystal behaves as if the distance $d_{(111)}$ was that between a plane R and a plane Cl, and we come back to the same result as before, that the spacings of the planes (100) (110) and (111) are apparently those of a simple cube lattice.

The analogy between this case and that of a line grating may help to elucidate this point. A line grating gives a series of spectra with monochromatic light, the equation

$$a \sin \theta = n\lambda$$

determining the positions of the spectra. Here a is the distance between line and line of the grating, and θ the angle through which the incident rays are diffracted. The angle at which the first spectrum occurs is given by

$$\sin \theta = \frac{\lambda}{a}$$

Suppose that every odd line of the grating were made a little wider than the even lines, so that it

diffracted more light, a spectrum would appear corresponding to the distance $2a$ between the widened lines; its angle would be given by

$$\sin \theta = \frac{\lambda}{2a}.$$

If the widening were small this spectrum would be very faint compared with the others, and it would appear at approximately half the angle of the first bright spectrum. Between the first and second bright spectra would be a faint one corresponding to

$$\sin \theta = \frac{3\lambda}{2a},$$

and so on. The peaks reflected from rock salt (111) are exactly analogous to the alternate bright and faint spectra reflected by such a grating. Parallel to this face the odd and even planes are of a different nature, like wide and narrow lines of the grating.

When the successive planes parallel to a face are identical as regards the action on the X-rays, the reflections diminish regularly in intensity as their order increases. If this regularity is absent it implies that the successive planes are different as regards spacing or constitution.

Zincblende, ZnS ,* is another binary compound which forms crystals belonging to the cubic system. The spectra of zincblende are shown diagrammatically in Fig. 29.

The first point to be noticed is that the first order

* W. H. Bragg and W. L. Bragg, *Proc. Roy. Soc., A*, Vol. 89, pp. 286, 473.

98 ANALYSIS OF CRYSTAL STRUCTURE

spectra have the same relative positions for the three faces as have those of rock salt. The ratio of the sines of the angles approximates closely to the ratio $1 : \sqrt{2} : \frac{\sqrt{3}}{2}$. It would appear that it is again the face-centred lattice that is the basis of the structure (Fig. 27 (b)).

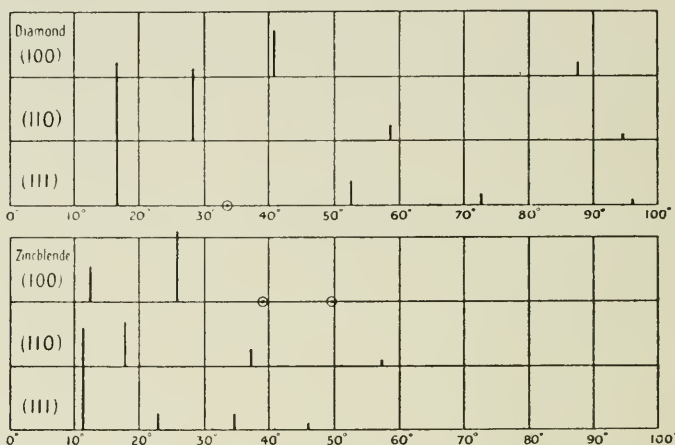

FIG. 29.

Further, we have for this crystal, for which $\rho = 4.06$, $M = 97$, $\theta_{(100)} = 12^\circ 20'$,

$$d \sqrt[3]{\frac{\rho}{M}} = .164\lambda ;$$

that is to say, there are as many atoms of zinc and sulphur to a unit cube of the structure as there are atoms of sodium and chlorine to the unit in NaCl. On the other hand, the arrangements of the atoms in both cases cannot be identical, as a comparison of the spectra of zincblende and rock salt will prove

at once. Since, firstly, the spectra indicate a face-centred lattice, and secondly, this comparison with rock salt shows that one molecule is associated with each point of the lattice, we will provisionally place the zinc atoms on a face-centred cubic lattice. We will then try possible arrangements of the sulphur atoms relatively to the zinc atoms, seeking to explain the observed spectra in this way.

In the zincblende spectra, it is the (110) planes which alone show a normal decrease in the higher orders. These planes have first, second, third order reflections which decrease in intensity in a normal manner. Therefore, the sulphur atoms must lie in the same (110) planes as the zinc atoms. The (100) planes, on the other hand, have a small first spectrum, just as do the (111) planes of rock salt. The sulphur planes must alternate with the zinc planes, and so tend to cut the first spectrum out as compared with the second. If the sulphur atom is to lie in the (110) planes, but halfway between the (100) planes (cf. Fig. 30 A), it must be placed at the centre of one of the small cubes, into eight of which the whole cube of that figure is divided.

The structure of rock salt as given in Fig. 28 may be regarded as composed of two intersecting face-centred cube lattices. The sodium atoms are arranged on one, the chlorine atoms on the other, and the two are relatively placed in such a way as to make up the structure there depicted. Let us now take zinc atoms on one face-centred lattice, sulphur atoms on another, but so place them relatively to each

100 ANALYSIS OF CRYSTAL STRUCTURE

other that the sulphurs come in the places we want them, *i.e.* at the centres of the small cubes of the zinc lattice. We get the structure shown in Fig. 30.

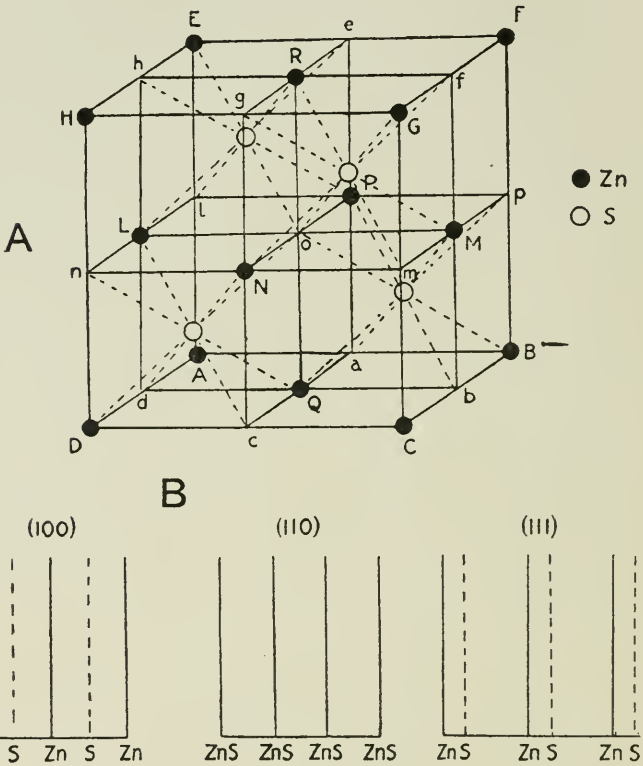

FIG. 30.

The representation of these three-dimensional figures is so complicated that only four sulphur atoms can be shown in the figure, this being all there are inside the unit cube of the structure. If the reader imagines cubes such as this put side by side so as to

continue the space lattice of zinc atoms, it will not be difficult to see that the sulphurs are really also on a face-centred lattice.

In Fig. 30B the arrangement of the planes parallel to (100), (110), (111) is shown diagrammatically. The zinc and sulphur atoms lie in the same (110) planes, and the simple structure of these planes corresponds to the regular set of spectra shown in Fig. 29. The arrangement of the (100) planes is like that of the (111) planes of rock salt (see Fig. 28). It is, again, the case of a grating with the odd lines stronger than the even lines. The first spectrum corresponds to the distance $d_{(100)}$ between the zinc planes, but it is weak compared to the second. The difference between the reflecting power of Zn (65) and S (32) is apparently greater than that between Cl (35.5) and Na (23), for the first spectrum of zinblende (100) is stronger comparatively than that of rock salt (111). Otherwise the two cases are similar.

The (111) planes are of a new type, the spacing of the sulphur planes being such that the distance Zn-Zn is four times the distance Zn-S.

It is not hard to see how this will influence the spectra. Although the sulphur planes are between the zinc planes, there is no reason why they should tend to cut out the first order reflection, as a matter of fact they slightly increase its intensity. For the second order reflection, however, the waves from the sulphur planes will be exactly out of phase with the waves from the zinc planes. At this

angle the wave train reflected from one zinc plane is two wave lengths behind the train from the next plane, *i.e.* the phase difference of these trains is 4π . The phase difference between zinc and sulphur is a quarter of this amount, and a phase difference of π means that the two trains are in opposite phase. We therefore expect that the second reflection will be weak as compared with the first and third. An inspection of the spectrum actually obtained, Fig. 29, shows that this is so, the third spectrum is if anything stronger than the second, while for a normal set of planes the second spectrum should be twice as strong as the third. In fine, our arrangement of zinc and sulphur atoms has successfully borne the test of explaining all peculiarities of the spectra reflected from the three principal faces of the crystal.

The next crystal to be considered is, perhaps, a more simple and certainly a more striking example of the laws governing the X-ray reflection, than either rock salt or zincblende. Zincblende has been discussed first here because it shows better the underlying face-centred cube lattice, which is the basis of its structure, and also of the one now to be considered.

Diamond,* one of the forms of carbon, forms crystals belonging to the cubic system. The spectra from faces (100), (110), (111) of diamond are given diagrammatically in Fig. 31, the spectra from the last face being given in detail in Fig. 32.

* W. H. Bragg and W. L. Bragg, *Proc. Roy. Soc., A*, Vol. 89, p. 277.

The first spectra occur at angles whose sines are in the ratio

$$2 : \sqrt{2} : \frac{\sqrt{3}}{2}.$$

This ratio is not characteristic of any space lattice

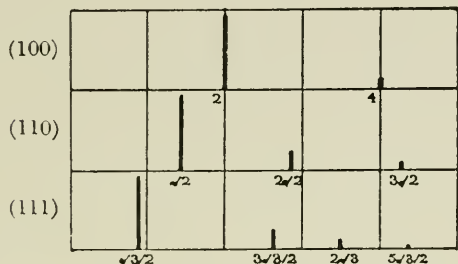

FIG. 31.

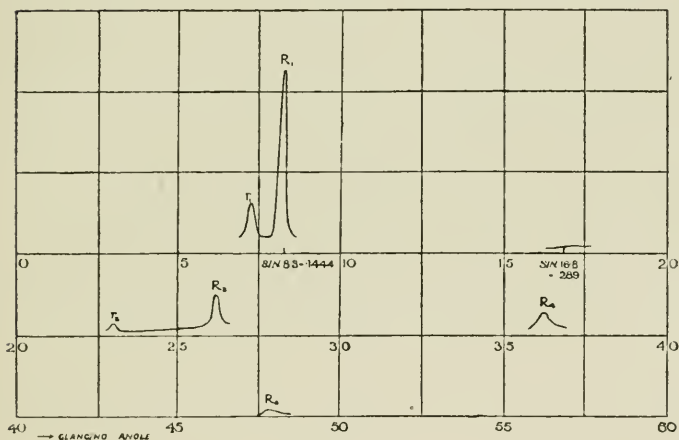

FIG. 32.

(cf. p. 93). Moreover, the spectra reflected from the face (111) are peculiar in that no trace of a second spectrum can be detected, although the first, third, fourth and fifth spectra are quite plain.

It is to be borne in mind that this peculiar feature has to be explained by the arrangement of one kind of atom only. In zincblende the second (111) spectrum was small because the sulphur planes divided the distance between the zinc planes in the ratio 1 : 3, but the second spectrum was not cut out entirely because the sulphur has atomic weight 32, as compared with zinc atomic weight 65. If the planes were to become identical in nature, retaining the same spacing, the second spectrum would entirely disappear. Moreover, the first (100) spectrum would disappear since all the (100) planes would also be identical in their nature. *The spectra would then become exactly like those of diamond.*

We are thus led to substitute carbon atoms for those both of zinc and sulphur in the zincblende structure, whereupon we get the structure shown in Fig. 33. The arrangements of planes parallel to the faces (100), (110), (111) can be got from the planes of zincblende by considering Zn and S equivalent. The planes parallel to the face (100) are closer together, and therefore throw the first spectrum farther out than either of the other sets of planes.

The planes (110) are $\sqrt{2}$ times, the (111) planes $\frac{4}{\sqrt{3}}$ times, as far apart as the planes (100). Our arrangement satisfactorily explains both the positions of the first spectrum from each face, and the peculiar fact that the face (111) has no second spectrum. The arrangement remains to be tested,

however, on one important point. Does it assign the right number of carbon atoms to each unit cube of the structure? If we are right in placing an

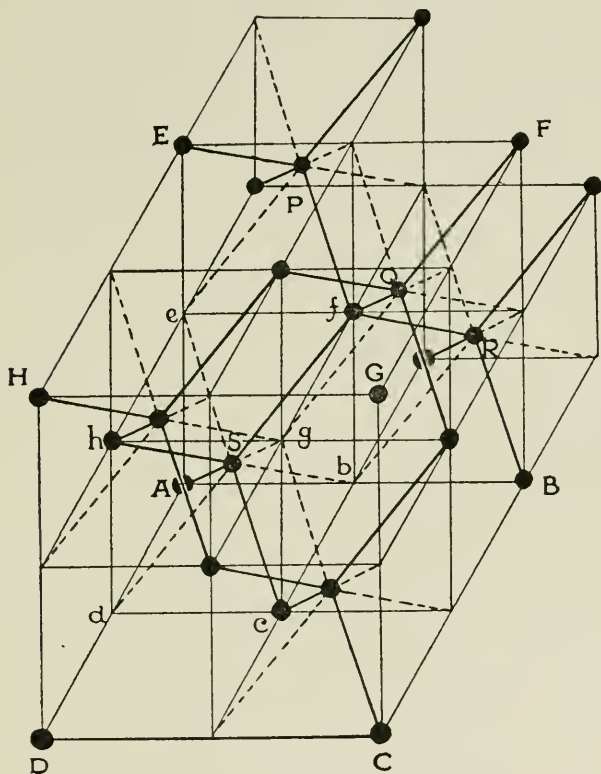

FIG. 33.

atom of carbon for each of zinc and sulphur in the structure, the diamond must fall into line with the other crystals as regards the relation we have found to exist between d , ρ , and M . To compare diamond with zincblende, we must compare the mass of two

carbon atoms with that of the molecule of zincblende, since a carbon atom replaces every atom of zincblende, whether of zinc or sulphur. We therefore put $M = 24$. The density of diamond is 3.51. For zincblende the distance d was calculated from the position of the first spectrum, the analogue to which is absent in the case of diamond. The corresponding distance d for diamond is double that between successive planes. It is given by

$$2\lambda = 2d \sin 19.0^\circ,$$

$$d = 3.06\lambda ;$$

$$\text{so } d \sqrt[3]{\frac{\rho}{M}} = 1.62\lambda, \text{ as before (p. 91),}$$

showing that zincblende and diamond do really possess the same number of atoms in each unit cube.

In the structure of the diamond as given in Fig. 33, the carbon atoms are arranged on two interpenetrating face-centred lattices. Each carbon atom of lattice B is surrounded by four carbon atoms belonging to lattice A , arranged tetrahedron-wise, and *vice versa*, just as each sulphur is surrounded by four zincs in Fig. 30.* This suggests a more simple way of considering the structure; we can draw links from atom to atom in such a way that each carbon atom is linked up to the four carbon atoms sur-

* A convenient way of getting the structure is to take a face-centred cubic lattice (A) and imagine it translated parallel to itself along a cube diagonal one-quarter of the length of the diagonal. The new position is that of the lattice B , and the points of both lattices (A) and (B) taken together give the positions of the carbon atoms.

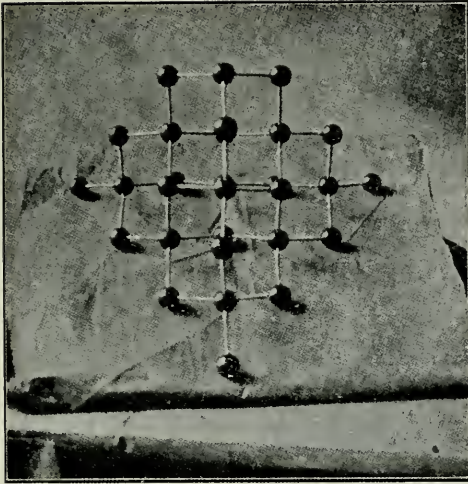

MODEL OF DIAMOND.

Horizontal and vertical planes perpendicular to the paper are (110) planes.

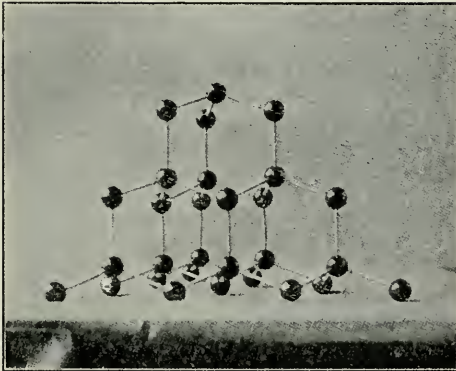

MODEL OF DIAMOND.

Horizontal planes perpendicular to the paper are (111) planes.

Facing page 106.

rounding it. We then drop the arrangement of cubes shown in Fig. 33, and obtain the structure of which a model is shown in Plate III. In these photographs the balls representing the atoms are built up into a tetrahedron, which rests on one of the faces (111). The arrangement of the planes parallel to this face in pairs, which possess the spacing of Fig. 30, can be traced very well in the photograph.

There remains one simple structure which is very similar to those considered above; it is that of fluor-spar, CaF_2 .* The spectra are sufficiently described by saying that they are identical with those of diamond. The structure which fits these spectra is quite simple. The calcium atoms are arranged in a face-centred cubic lattice, while the fluorines occupy the centres of the small cubes, as do the sulphur atoms in zincblende (Fig. 30). In this case, however, we have twice as many fluorine atoms as calcium atoms; we must therefore place fluorine atoms at the centres of all the small cubes, instead of choosing only one-half of the cubes, as in the zincblende structure. The structure and the arrangement of the principal planes is then given by Fig. 34. This arrangement gives the right value for the molecular volume of fluor-spar, as in the case of the other crystals.

The spectra of fluor have an especial interest for the following reason. It will be noticed that in this case, as in that of diamond, the first (100) spectrum

* *Proc. Roy. Soc., A*, Vol. 89, p. 474.

and second (111) spectrum are absolutely extinguished. In diamond the (100) planes belonging to lattice *A* (see p. 106) are interposed with planes belonging to lattice *B*, of an identical nature, and the first spectrum naturally disappears. In the case of fluor-spar the planes containing calcium atoms are interposed with planes containing twice as many fluorine atoms, and the observed disappearance of the first spectrum shows that the calcium planes and fluorine planes are nearly the same as regards

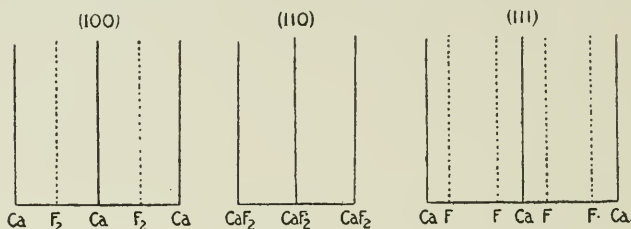

FIG. 34.

reflecting power. Just as we may balance C against C in diamond, and K against Cl in sylvine, so we may balance Ca against F₂. The potassium atom balances the chlorine, because their weights are nearly the same. It is possible that Ca balances F₂ for the reason that $\text{Ca} = 40$, $\text{F} + \text{F} = 19 + 19 = 38$. This suggests that the reflecting effect of a plane is proportional to its mass per unit area. In the next chapter we shall describe some examples which give strong support to this view; a view which simplifies considerably the analysis of more complicated structures.

In the series of crystals which we have considered,

we have linked up the the angles of reflection for the face (100) of each crystal by means of the quantity $d\sqrt[3]{\frac{\rho}{M}}$. This quantity has the same value, viz. 1.62, for each member of the series.

The constancy of this quantity shows that the crystals form a self-consistent series, since in each case the nature of the spectra, and the angles at which they occur, when compared between themselves, are satisfactorily explained by the structures assigned to the crystals. We are justified in assuming that the structures must at any rate approximate closely to the arrangement of atoms in the crystal. There may be slight distortions of the crystal of which the spectra give no evidence, but at any rate the 'marshalling' of the atoms is as we have represented it to be. This being assumed, we may proceed to calculate the wave length of the radiation we are using. Take a face-centred cubic lattice. The unit cube of the lattice as represented in Fig. 27 (*b*) has four points associated with it, that is to say, in any given volume of the lattice there are four times as many points as the volume contains cubes. The whole cube has eight corner points, each of which is common, however, to eight cubes in all, so that these points only count as one. The six points on the faces are each common to two cubes, so that they can be reckoned as three, making the total number associated with the cube four. Each of the small cubes of Fig. 27 (*b*) may be said to be associated with half a point. Passing now to

110 ANALYSIS OF CRYSTAL STRUCTURE

the structures we have found for the various crystals, it follows that, associated with the small cubes, we have respectively

$$\frac{\text{KCl}}{2}, \frac{\text{NaCl}}{2}, \frac{\text{ZnS}}{2}, \text{C}, \frac{\text{CaF}_2}{2}.$$

If m is the mass of a hydrogen atom in grams, M the molecular weight of the substance, the mass associated with unit cube of the structure is $Mm/2$ in every case.

On the other hand, the volume of the elementary cube is equal to $(d_{(100)}^3)$, where $\lambda = 2d_{(100)} \sin \theta$. If the density of the crystal is ρ , the mass of unit cube must be $\rho(d_{(100)}^3)$. We therefore have

$$\left(\frac{1}{2}M\right)m = \rho(d_{(100)}^3).$$

(It is, of course, a mere coincidence that for four of these crystals half a molecule is associated with the same cube.)

Taking the case of rock salt, NaCl, and substituting

$$\begin{aligned} \frac{1}{2}M &= 29.25, & m &= 1.64 \times 10^{-24} \text{ grams,} \\ \rho &= 2.17, \end{aligned}$$

we obtain the result, $d_{(100)} = 2.80 \times 10^{-8}$ cm., and hence

$$\lambda = .576 \times 10^{-8} \text{ cm. ;}$$

and since $d\sqrt[3]{\frac{\rho}{M}}$ is approximately constant for all these crystals, they all give the same value for λ .

Let us suppose that we are investigating a new cubic crystal, whose structure is as yet unknown. We take ammonium chloride (NH_4Cl) for example. It is found that the first spectrum from the face (100) occurs at a glancing angle, 4.25° .

$$\begin{aligned} \text{Hence, } .576 \times 10^{-8} &= 2.d_{(100)} \sin 4.25^\circ, \\ d_{(100)} &= 3.88 \times 10^{-8} \text{ cm.} \\ \rho(d_{(100)})^3 &= 88.2 \times 10^{-24} \text{ grams.} \end{aligned}$$

The mass of a molecule NH_4Cl is equal to

$$1.64 \times 10^{-24} \times 53.5 = 87.8 \times 10^{-24} \text{ grams.}$$

It is therefore clear that each unit cube of the structure contains one molecule, and this is the first thing to be considered when arranging the atoms so as to account for the observed spectra.

In this way, having once determined the absolute wave length of the palladium rays, we can measure in centimetres any spacing of any crystal we please.

Whatever class of symmetry the crystal belongs to, this enables us to measure up an elementary cell of its structure, and so to find the mass contained in it by multiplying its volume by the density of the crystal. A comparison with the known mass of a molecule of the substance at once informs how many molecules are contained in the unit cell. Having found this, the spectra from the various faces are compared in order to find the disposition of the atoms in this unit cell, and in this way we determine the structure of the crystal.

CHAPTER VIII.

THE ANALYSIS OF CRYSTAL STRUCTURE. PT. II.

THE compounds MgCO_3 (Magnesite), CaCO_3 (Calcite or Iceland spar), MnCO_3 (Rhodochrosite), FeCO_3 (Chalybite), ZnCO_3 (Calamine), all occur in nature as crystals which strongly resemble each other, and constitute one of the best known series of isomorphous minerals. They belong to a rhombohedral class of the hexagonal system. The crystal in each case has an axis of threefold symmetry, with three symmetry planes intersecting in it, and three axes of twofold symmetry at right angles to it. A rhombohedron of calcite is shown in Fig. A, and it serves to illustrate the arrangement of these axes and planes of symmetry. The edges of the rhomb are all equal; so are the angles AOB , BOC , COA . The axes of symmetry are marked in the figure, OO' being the trigonal axis. Digonal axes pass through the middle points of opposite edges, such as BD and EA . The planes of symmetry pass through OO' and the edges OA , OB , OC respectively.

The crystals cleave parallel to the faces of these rhombs, in a very perfect manner. We may take

provisionally cells of this shape as being the unit cells of the structure, and suppose the whole crystal built up by stacking together such unit cells. Three edges of the rhomb which meet in the axis of three-

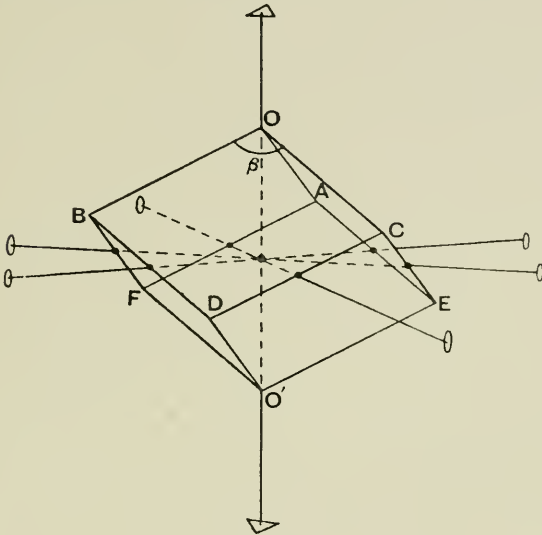

FIG. 35.

fold symmetry, such as OA , OB , OC , are taken as the axes of the crystal. They are, of course, of equal length, in accordance with the threefold symmetry, and they all make the same angle with each other. For calcite this angle is $101^\circ 54'$; and it is within two degrees of this value for all the crystals of the series. When OA , OB , OC are taken as axes, the face OBC becomes the face (100) of the crystal. The face ABC has indices (111) . The angle BOC , which defines the form of the rhomb, is denoted in the figure by the symbol β .

114 ANALYSIS OF CRYSTAL STRUCTURE

If we determine the angle at which X-rays of known wave-length are reflected by any face of the rhomb we can calculate the spacing of the planes parallel to this face. Let $d_{(100)}$ denote this distance. The angle of reflection of the principal palladium ray is found to be 5.35° , and, substituting in the usual formula, we find that $d_{(100)} = 3.07 \times 10^{-8}$ cm. As we know the form of the rhomb, we can easily find the volume of the elementary cell, in which $d_{(100)}$ is the perpendicular distance between any pair of opposite faces. It is $1.08 \times d_{(100)}^3$. The density of calcite being 2.71, the mass contained in this elementary cell is

$$2.71 \times 1.08 \times (3.07)^3 \times 10^{-24} = 8.50 \times 10^{-23} \text{ gr.}$$

Now the mass of a molecule of CaCO_3 is

$$(40 + 12 + 48) \times 1.64 \times 10^{-24} = 16.4 \times 10^{-23} \text{ gr.}$$

This preliminary investigation shows, therefore, that there must be half a molecule of CaCO_3 in each elementary cell. This gives a hint as to the space lattice on which the calcium atoms, as representing the whole molecules, must be arranged. Imagine a lattice built up of cells having the same shape as the elementary cell just considered, but of twice the linear dimensions and eight times the volume. Place points at each corner and at the centre of each face of every such cell. There are then four points to each cell, as explained in the case of the similar cubic structure on page 109, for we may regard the rhomb as a distorted cube. If one molecule of CaCO_3 is arranged around each point of the lattice, there are four molecules of CaCO_3 in the face-centred

cell. The spacing of the planes parallel to the side of the cell, which we call $d_{(100)}$, is equal to half the distance between opposite faces of the new cell, just as it is equal to half the side of the cube for a face-centred cubic lattice.

We may now calculate the spacings in centimetres characteristic of any plane of this lattice, proceeding as follows. We regard the above preliminary calculation as merely indicating the number of molecules associated with the unit cell. We take this number to be four and, starting from this point, commence our calculations afresh. We begin with $d_{(100)}$, which is now a quantity to be calculated. We know that the volume of the unit cell is $1.08 (2d_{(100)})^3$, the density of calcite 2.71. Therefore the mass in the unit cell is

$$1.08 \times (2d_{(100)})^3 \times 2.71 \text{ grams.}$$

This cell contains four molecules of CaCO_3 , each weighing 1.64×10^{-24} grams. We have

$$1.08 \times 2d_{(100)}^3 \times 2.71 = 4 \times 164 \times 10^{-24},$$

$$d_{(100)} = 3.04 \times 10^{-8} \text{ cm.}$$

From the calculated value of $d_{(100)}$ we can find the angle at which the Pd rays should be reflected.

We have

$$\lambda = 2d \sin \theta_{100},$$

$$.576 \times 10^{-8} = 2 \times 3.04 \times 10^{-8} \sin \theta_{100},$$

$$\sin \theta_{100} = .0950,$$

$$\theta_{100} = 5.4^\circ.$$

We may calculate d_{111} , d_{110} , etc., in the same way. The table below gives a comparison of the angles at which reflections from the faces are actually observed,

116 ANALYSIS OF CRYSTAL STRUCTURE

and the angles at which the calculations would lead us to expect them :

PLANE.	CALCULATED SPACING.	CALCULATED ANGLE.	OBSERVED ANGLE.
100	$d_{(100)} = 3.04 \times 10^{-8}$ cm.	5.43°	5.35°
$1\bar{1}0$	$d_{(1\bar{1}0)} = 2.48 \times 10^{-8}$ cm.	6.67°	6.6
110	$d_{(100)} = 1.917 \times 10^{-8}$ cm.	8.63°	8.70°
111	$d_{(111)} = 2.79 \times 10^{-8}$ cm.	5.92°	5.77°
$2\bar{1}\bar{1}$	$d_{(2\bar{1}\bar{1})} = 1.43 \times 10^{-8}$ cm.	11.59°	11.65°

Since the calculated values agree with those actually found in all cases, and are not, for example, half or twice or three times, it is evident that a right choice of lattice has been made.

The peculiar features of the spectra from each face are now employed to determine the arrangement of the atoms of the CaCO_3 molecule which is associated with each point of the lattice. It is not necessary to enter into the examination here; the results will alone be given. The structure which is finally arrived at by a study of the spectra is shown in Fig. 36. A full account of the way in which it is worked out will be found in the original paper.*

In Fig. 36, for the sake of simplicity, only calcium and carbon atoms are shown in their places in the unit cell of the structure. For the purpose of showing the arrangement of the oxygen atoms, the structure is given as a series of layers perpendicular to the trigonal axis, in Fig. 36B. The way in which these layers are taken from the unit rhomb is sufficiently explained by the lettering of the figures.

* *Proc. Roy. Soc., A*, Vol. 89, p. 468, 1914.

From Fig. 36, it is apparent that the arrangement of the planes perpendicular to the trigonal axis can be expressed very simply. The planes are evenly spaced, and they contain alternately calcium atoms

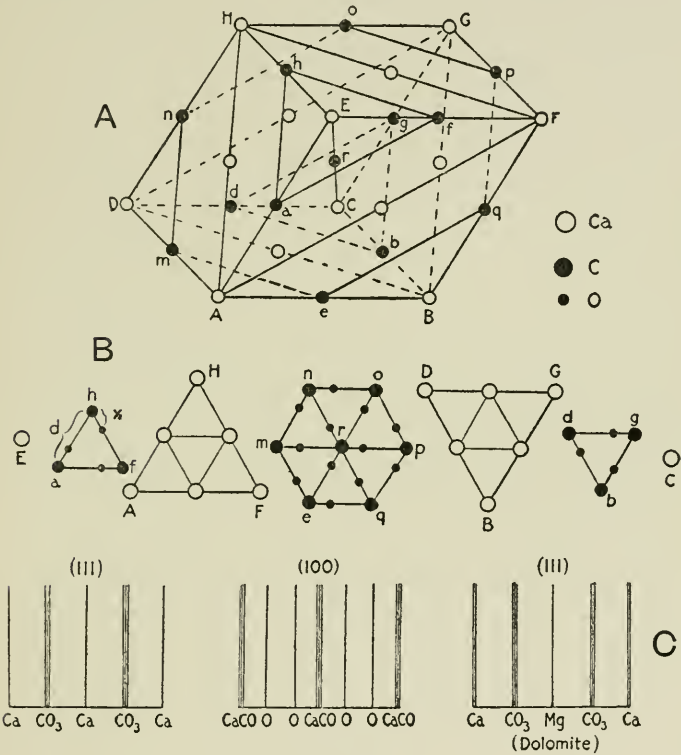

FIG. 36.

and groups of the composition CO₃. This arrangement is represented diagrammatically in Fig. 36c. The planes containing the group of CO₃ of weight (12 + 3 × 16 = 60) are evenly spaced with the planes containing calcium, of weight 40.

The structure of each crystal of the calcite series is similar to that of calcite itself; and in particular they all have a similar arrangement of planes perpendicular to the trigonal axis. Moreover there is another crystal which though of very different composition imitates the calcite series so closely in its crystalline shape and molecular volume that it has always been supposed to be built up in the same way. This substance is sodium nitrate, NaNO_3 . An investigation of its reflection spectra shows that this similarity is indeed the result of similarity of composition. As still another crystal of the same structure, we have dolomite, $\text{Ca.Mg}(\text{CO}_3)_2$. Its similarity to calcite is so great that, although it is of so much more complicated a composition, we are almost certainly justified in treating it for the time being as a simple carbonate, the atomic weight of the metal being taken to be the mean of those of calcium and magnesium.

The results of the examination of this series of crystals is shown in Fig. 37, the reflecting surface being in each case the (111) plane.

The spacing $d_{(111)}$ is, throughout, the distance between two CO_3 planes as in Fig. 36c. But half-way between these planes are the metal planes. The effect of the latter is, as in previous similar cases, to decrease the first order reflection and increase that of the second order. If the metal planes were of negligible effect compared with the CO_3 planes, the first, second, and third spectra would diminish regularly in intensity. If the metal planes had an

effect equal to that of the CO_3 planes, we would have to consider the distance $d_{(111)}$ as being halved. The first spectrum would be entirely destroyed, for the waves from the CO_3 and metal planes would be equal in amplitude and opposite in phase. If the effect of the metal planes is anywhere between the two

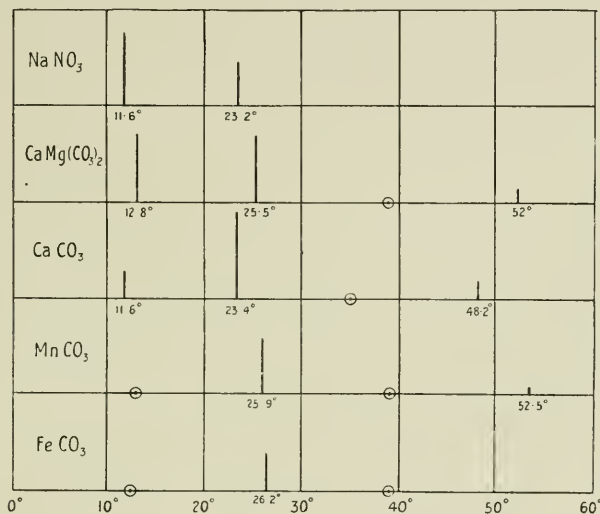

FIG. 37.

extremes, the effect will be that the ratio of the second spectrum to the first is larger than the normal.

In the series of spectra of Fig. 37, we see the effect of the progressive change of the atomic weight of the metal throughout this series of carbonates. The gradual disappearance of the first spectrum, as the alternate planes approximate in their reflecting effect, can easily be observed. In NaNO_3 , the Na

planes have little effect compared with the NO_3 planes, and the first spectrum is greater than the second. In FeCO_3 , the Fe planes must be equal to the CO_3 planes in reflecting power, for the first spectrum is extinguished.

We conclude that the alternate planes become equal in reflecting power when their masses per unit area are equal. The atomic weight of iron is 56, the sum of the atomic weights of the CO_3 group is 60. We have seen that a calcium atom balances two fluorine atoms, we now see that an iron or manganese atom balances the group CO_3 . This is therefore direct evidence that the reflecting power of the atom is proportional to its atomic weight.

When analysed, this means that the amplitude of the diffracted wavelet, as an X-ray wave passes over an atom, is proportional to the atomic weight of that atom. The argument may be put as follows: It is found that the first spectrum of equally spaced sets of planes A and B is entirely cut out. This implies that a single pair of planes A and B reflects two trains which annul each other. For if this were not true for each pair considered separately, the planes might be grouped into pairs each of which reflected a certain amount of the incident wave train, and these amounts would add together to give a first spectrum. This reasoning can be extended, and it can be said that if A and B contain Fe atoms and CO_3 groups respectively in equal number per unit area, each Fe atom must exactly balance each CO_3 group. That is to say, the amplitude at any given point due to the

diffraction of a wave train by the iron atom must be equal to the sum of the amplitudes due to diffraction by the atoms of the CO_3 group. The only simple explanation is that the amplitude is proportional to the atomic weight. At any rate, since the effects of carbon and oxygen must be nearly the same, each must be one quarter as effective as iron. In the case of fluor-spar, we have seen that the effect of fluorine is half that of calcium. It will be shown later that the effect of a sulphur atom is rather more than half that of an iron one.

In these few instances the law, that the amplitude is proportional to the atomic weight, can be directly tested. There are numerous instances where it can be tested in a less direct manner. The evidence seems strong enough to justify the provisional assumption that the law holds good for all atoms. We are now, therefore, in a position to attack the general case in which planes that are not of identical nature are spaced, not at regular intervals, but according to some more complicated law. Suppose that in a crystal there are parallel reflecting planes of two kinds, A and B , arranged alternately and parallel to the crystal face. Suppose that they have relative masses M_1 and M_2 , M_1 and M_2 being the sums of the atomic weights of groups of atoms occurring in equal numbers in the two planes. We now wish to find the influence of spacing upon the strength of the reflected beam. Let the distance between two A planes be d , that between an A and a B plane x .

122 ANALYSIS OF CRYSTAL STRUCTURE

If x is made zero, the successive planes become identical in character. Such an arrangement of planes gives, as we have seen, a series of spectra which diminish regularly in intensity. Their intensities may be called

$$I_1, I_2, I_3, I_4, \text{ etc.}$$

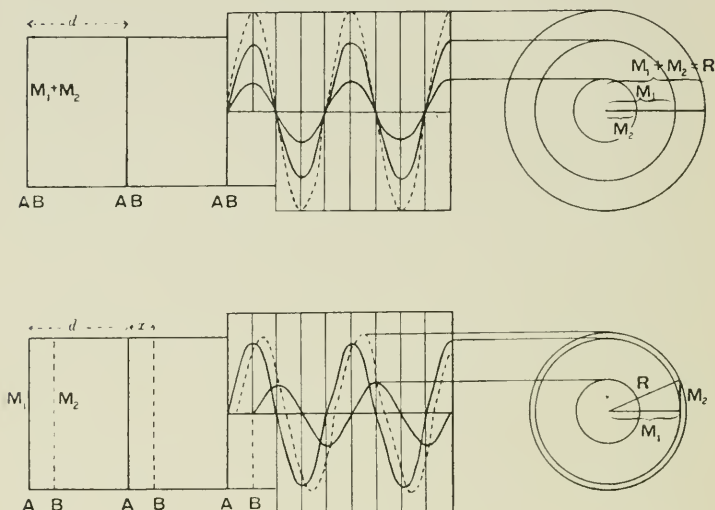

FIG. 38.
A and B Planes.

Under these circumstances the planes A and B reflect waves which are in the same phase. Taking a single plane AB , the amplitude of the reflected wave is the sum of the amplitudes due to A and B independently. See Fig. 38 (upper part).

Since the amplitude is proportional to the 'mass' of the plane, the intensity is proportional to

$$(M_1 + M_2)^2.$$

When x is not zero, the waves from the A planes and those from the B planes are not in phase with each other. Each pair of planes sends off two wave trains of the same length, but differing in phase and amplitude (Fig. 38 (lower part)). There is a well-known method of finding the resultant of two such trains, which is shown in the same figure. The phase difference θ of the two sets of waves is given by

$$\begin{aligned}\frac{\theta}{2\pi} &= \frac{x}{d} \text{ for the first spectrum} \\ &= \frac{2x}{d} \text{ for the second spectrum} \\ &= \frac{3x}{d} \text{ for the third spectrum,}\end{aligned}$$

and so forth. The amplitudes are proportional to M_1 and M_2 . The amplitude of the resultant wave is proportional to R , where R is the resultant of two vectors M_1 and M_2 , making an angle θ with each other, so that $R^2 = M_1^2 + M_2^2 + 2M_1M_2 \cos \theta$.

The energy of the reflected wave train is proportional to the square of the amplitude. When the planes are coincident this energy is proportional to $(M_1 + M_2)^2$. When they are not it is proportional to $M_1^2 + M_2^2 + 2M_1M_2 \cos \theta$.

Comparing then the intensities of the reflections for the two cases

(1) when $x=0$ the reflections have intensities

$$I_1, I_2, I_3, I_4, I_5,$$

(2) when $x \pm 0$ they have intensities $I_1', I_2', I_3', I_4', I_5'$, where

$$I_1' = \frac{I_1 M_1^2 + M_2^2 + 2M_1 M_2 \cos \frac{2\pi x}{d}}{(M_1 + M_2)^2}$$

$$I_2' = \frac{I_2 M_1^2 + M_2^2 + 2M_1 M_2 \cos \frac{4\pi x}{d}}{(M_1 + M_2)^2},$$

and so on.

As an example of the quantitative estimation of the intensities, let us take the spectra of rock salt. The planes (100) and (110) are of the simple type, in which all planes are identical, and they give a series of spectra which decline regularly in intensity, as is found to be usual in such cases. But the planes (111) are not simple, and the intensities of their spectra show abnormal relations. Consider the following figures, which are taken from a table given in the original paper:—

Plane	I_1	I_2	I_3	I_4
(100)	100	30	7	3
(110)	100	24	7	—
(111)	20	100	0	6

The first two sets of spectra show differences which may be ascribed in part to errors of experiment, and in part to irregularities of the crystal, always quite obvious.* The third shows an abnor-

* But according to the theory discussed in Chap. XI. the difference may be partly real. It should be mentioned that the experimental values given here are those which were available at the time when the method was first used, and the empirical relations between I_1, I_2, I_3 , etc., are those which then seemed to be most in accordance with facts. They were sufficient for their purpose, and we have therefore reproduced them without alteration. In Chap. XI. the question is discussed more fully and with later experimental evidence.

mality of quite a different order, for which we now proceed to give a sufficient reason.

If the Na and Cl atoms were in the same planes, parallel to the (111) face, as they are in the case of the faces (110) and (100), we would expect this face to give a series of spectra diminishing regularly in intensity. One might, from comparison, say that the spectra would then be roughly in the proportion

$$I_1 : I_2 : I_3 : I_4 :: 100 : 30 : 7 : 3.$$

We now apply our analysis. We have,

$$M = 35.5, \quad M_2 = 23, \quad \frac{x}{d} = \frac{1}{2}.$$

This gives $I'_1 = I_1 \frac{(35.5 - 23)^2}{(35.5 + 23)^2} = .045 I_1,$

$$I'_2 = I_2,$$

$$I'_3 = .045 I_3,$$

$$I'_4 = I_4.$$

Thus the arrangement of sodium and chlorine planes being what it is, we expect to find, instead of spectra of intensities $I_1, I_2, I_3, I_4,$ a series of values given by

$$I'_1 : I'_2 : I'_3 : I'_4 :: 4.5 : 30 : .3 : 3 \\ :: 15 : 100 : 1 : 10,$$

which agree closely enough with the experimental values, 20 : 100 : 0 : 6.

In short, the spectra of the face (111) of the crystal have been brought into line with those of the faces (110) and (100). We have accounted quantitatively as well as qualitatively for their abnormal relative intensities.

Again, let us take the case of zincblende (100) (see Fig. 30). Here we have

$$M_1 = 65, \quad M_2 = 32, \quad \frac{x}{d} = \frac{1}{2};$$

calculating as before we find that

$$I_1' = .116 I_1, \\ I_2' = I_2, \text{ etc.}$$

The experimental ratio of first to second reflection for this face is 52 : 100, which is quite abnormal. The explanation, of course, is that the zinc and sulphur planes occur alternately. If the sulphur and zinc atoms had been in the same planes, our calculation shows that the ratio would have been

$$\frac{52}{.116} : 100 = 100 : 22, \text{ which is normal.}$$

We must not expect nor demand too close an agreement between calculated and observed intensities. We estimate the values of the ratios $I_1 : I_2 : I_3$ from the behaviour of other planes of the crystal, which are, as between themselves, identical in all respects. The measurements of these quantities have been subject to considerable inaccuracy, so that other values which are derived from them must remain uncertain also. Accurate methods are now available, but there has not been time to redetermine all the ratios which we are considering. This does not render the quantitative relations of the spectra, as already found, useless for the purpose of finding the relative positions of the planes *A* and *B* in our examples. The ratios of the intensities may vary

through so wide a range that approximate values give quite valuable information. Take, for instance, the planes NaCl (111), and suppose, for the purpose of argument, that the position of the chlorine planes relative to the sodium planes was uncertain. If the Na and Cl atoms were in the same planes, the intensities would be expected to have a ratio approximating to

$$100 : 30 : 7 : 3.$$

If the Cl atoms were so placed that $\frac{x}{d} = \frac{1}{4}$ calculation alters the ratio to

$$100 : 2.6 : 7 : 5.5.$$

If $\frac{x}{d} = \frac{1}{2}$, as is actually the case, the ratio is calculated to be

$$15 : 100 : 0 : 10.$$

The actual values (see above) are 20 : 100 : 0 : 6.

When $\frac{x}{d}$ changes from $\frac{1}{4}$ to $\frac{1}{2}$, the ratio of the first to the second spectrum changes from 100/2.6 to 15/100. This very rapid change of the ratio of the spectra with alteration in the spacing of the planes, makes it possible to determine the spacing to a high degree of accuracy, although so many assumptions are made about the quantitative part of the work.

Iron pyrites.

Iron pyrites, another cubic crystal, provides a good instance of the way in which this quantitative analysis can be made useful, and as the structure is also

128 ANALYSIS OF CRYSTAL STRUCTURE

interesting from the point of view of crystalline symmetry, it is worth while entering into it in some detail.

The spectra of iron pyrites are given in Fig. 39. It will be seen that they are a more complicated set of spectra than any as yet examined. The planes

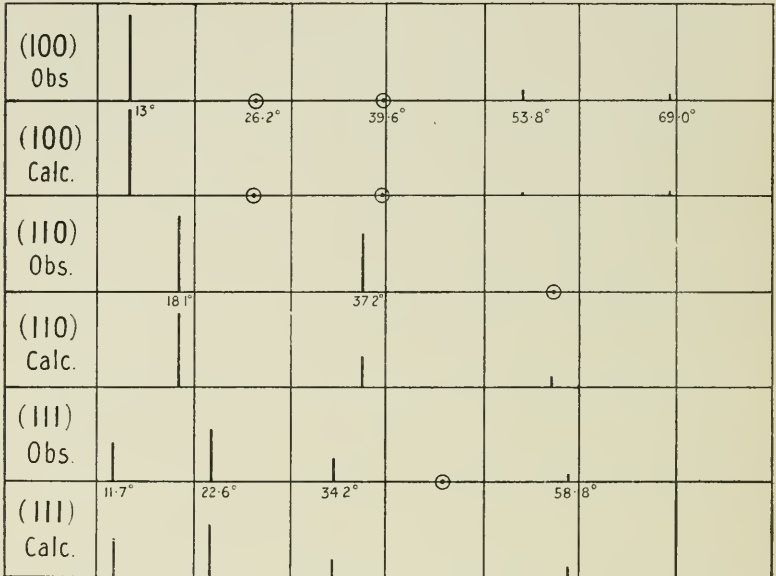

FIG. 39.

parallel to all three types of faces have a complex arrangement, as shown by the peculiarities of their respective spectra. In no case is there a regular succession of spectra diminishing in intensity towards the higher orders.

The first spectra are in each case very plainly marked. They occur at angles 13° , 18.1° , 11.7°

(rhodium bulb), and the sines of the glancing angles have the ratio

$$1 : \sqrt{2} : \frac{\sqrt{3}}{2},$$

which is characteristic of the face-centred cubic lattice. This lattice being chosen as characteristic of the crystal structure, calculation shows that one molecule of FeS_2 is associated with each point of the lattice.

Therefore when marshalling the atoms into their positions in the crystal, one iron atom and two sulphur atoms must be associated with each point. The most simple way in which this can be done corresponds to the structure of fluor-spar (see p. 107). The iron atoms would then lie on a face-centred lattice, while the sulphur atoms would occupy the centres of all the small cubes of the figure.* In all the cubic structures so far dealt with, it is at these cube centres and corners that we have found the atoms to be placed. If we limit ourselves to these positions, and wish to build up a structure with one molecule of FeS_2 to each point of a face-centred lattice, this particular arrangement characteristic of fluor-spar is the only way in which it can be done.

Such an arrangement will not fit the observed spectra in any way. Sulphur is approximately of half the atomic weight of iron, as fluorine is of calcium, and therefore we should expect the spectra typical of each face to be more or less the same for

* Compare Fig. 30, where *four* of the centres are occupied.

the two crystals. This is far from being the case. The (100) spectra, for instance, have a strong first and no second spectra in iron pyrites, no first and a strong second in fluor-spar.

The sulphur and iron atoms in FeS_2 cannot be in these very symmetrical positions, viz. at cube corners and centres. Some of the elements of symmetry must be sacrificed in order to explain the spectra observed.

In Fig. 40 (*a*) represents a small cube of the fluor-spar structure of p. 107. It has a fluorine atom at its centre and calcium atoms at four of its corners.

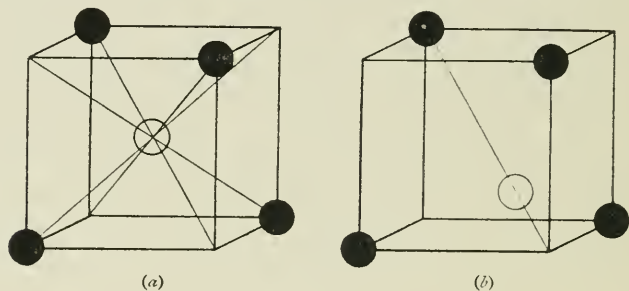

FIG. 40.

The four diagonals which are drawn intersecting in the centre of the cube are axes of threefold symmetry of the whole structure, and are, of course, continuous through whole strings of cubes. Four such axes pass through each corner of the cube, of which only one appears in the figure.

If the atom at the centre of the cube is to be displaced from its position, it is impossible to retain the four axes of symmetry passing through it. One

at most can be retained, the atom sliding along a diagonal as in Fig. 40 (*b*). If it left the axis every trigonal axis would be destroyed and the crystal would be no longer cubic. In pyrites the displaced atom is the sulphur atom, the iron atoms being at the corners. Each sulphur atom has only one trigonal axis passing through it, while the fluorine had four. Similarly, each iron atom lies on only one trigonal axis.

In Fig. 40 (*b*), one axis going through one of the atoms is shown; the axes which pass through the other three iron atoms lie in neighbouring cubes. This arrangement, which is perhaps rather difficult to visualise, may be made more clear by Fig. 41, which shows eight of the cubes stacked together in two sets of four, the sets being separated so as to make the construction more obvious. In each cube one diagonal is drawn, and none of these diagonals intersect each other. Each diagonal making a trigonal axis is continued in both directions and is common to a whole string of cubes.

We may think of the sulphur atom as initially in a symmetrical position at the cube centre. It lies on one of these chosen diagonals, the diagonal having an iron atom at one end and an empty corner at the other. To arrive at the actual crystal structure the sulphur atoms are now displaced by equal amounts along the diagonals, and it remains to be found by how much. So long as the typical sulphur atom lies on the chosen diagonal symmetry alone gives no reason why it should be at one place more

than another. Its exact position must be found by *quantitative* measurements of the strengths of the spectra. Placing the sulphur atom at different points along the diagonal, it is possible to calculate theoretically the relative intensities of the spectra, in the way employed above in the case of rock salt and zinblende. These theoretical values are then compared with the actual spectra obtained, and it appears

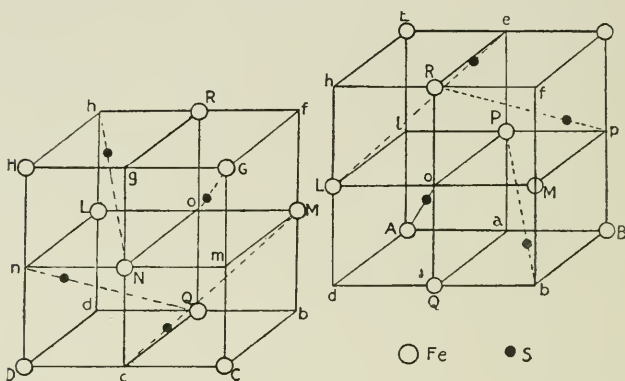

FIG. 41.

that there is only one position for the sulphur atoms which explains the facts.

A first approximation to the position of the sulphur atoms can be got from the (100) spectra. The first spectrum is large, the second and third are too small to detect, and the fourth and the fifth easily measurable. The iron atoms lie on (100) planes whose distance apart is that of two opposite sides of the cube in Fig. 40 (b), and the sulphur atoms lie between them. If the distance between sulphur planes and iron planes were $d_{(100)}/4$, the sulphur planes would

tend to destroy the second spectrum (cf. diamond). If this distance were $d_{(100)}/6$, it would tend to destroy the third spectrum. Since it is actually found that both have become too small to observe, the distance must be about $d_{(100)}/5$.

In order that it may have this value, the sulphur atom must be displaced along the diagonal until it divides it in the ratio 1:4. As far as these planes go, the displacement may take place either towards or away from the iron atom along the diagonal without altering the spectra, but consideration of the spectra of the (111) planes shows that the displacement takes place towards the empty corner and away from the iron atom, as in Fig. 40 (*b*).

Let us sum up the whole structure, now that this displacement has been approximately determined. The iron atoms are arranged on a face-centred cubic lattice. A series of non-intersecting threefold axes are then chosen, one passing through each iron atom, so that each small cube of Fig. 41 has a single diagonal which is a threefold axis. Each cube contains one sulphur atom, which lies on the diagonal near the empty cube corner and divides the diagonal in the ratio 1:4. The symmetry of this structure is still that of the cubic class; it will be discussed in the next chapter.

The planes (100), (110), (111) are arranged as in Fig. 42, which also gives the structure.

These planes are of a much more complicated kind than the simple AB , AB type arrangement hitherto considered. The intensities of the spectra

are calculated, however, in exactly the same way, except that we must now find the resultant of several vectors instead of that of two only. As an instance, take the planes (100), whose arrangement is of a simple type. Each plane containing the iron atoms lies between a pair of planes containing sulphur atoms. The quantity x/d for these planes is equal

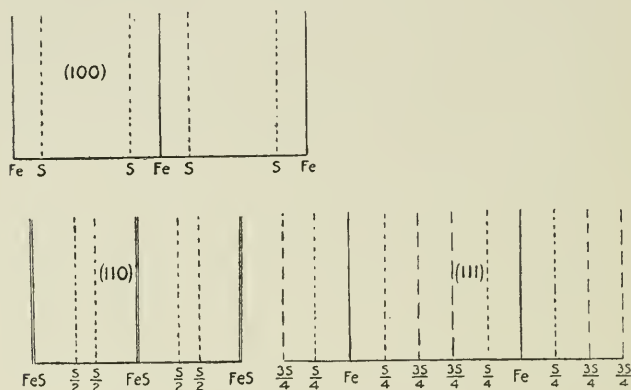

FIG. 42.

to $1/5$, which means that the wave trains from the pair of sulphur planes differ in phase from that from an iron plane by $2\pi/5$ for the first spectrum, $4\pi/5$ for its second, $6\pi/5$ for the third, and so forth.

We have therefore

$$\frac{I_1'}{I_1} = \frac{\left(56 + 2 \cdot 32 \cdot \cos \frac{2\pi}{5}\right)^2}{(56 + 64)^2} = \left(\frac{76}{120}\right)^2 = .40,$$

$$\frac{I'_2}{I_2} = \frac{\left(56 + 2.32 \cdot \cos \frac{4\pi}{5}\right)^2}{(56 + 64)^2} = \left(\frac{4}{120}\right)^2 = .00111,$$

$$\frac{I'_3}{I_3} = \text{etc.} = .00111,$$

$$\frac{I'_4}{I_4} = \text{etc.} = .40,$$

$$\frac{I'_5}{I_5} = \text{etc.} = 1.$$

We assume, as before, a set of intensities declining in normal fashion, such as

$$I_1 : I_2 : I_3 : I_4 : I_5 :: 100 : 20 : 7 : 3 : 1.$$

In this case we have no simple iron pyrites planes from which we may obtain guidance in the choice of these ratios, and we are obliged to fall back on average values obtained from the study of a number of other crystals. The calculated values of $I'_1, I'_2, I'_3, I'_4, I'_5$, for the (100) planes, become $I'_1 = 40, I'_2 = .02, I'_3 = .007, I'_4 = 1.2, I'_5 = 1$, so that the ratios of the intensities of the spectra may be put

$$100 : 0 : 0 : 3 : 2.5.$$

Carrying out the same calculation for the planes (100), (111), the ratio for these planes is found to be

$$\begin{array}{l} (110) \quad 100 : 50 : 18 : 3 : 4, \\ (111) \quad 72 : 100 : 35 : 2 : 20. \end{array}$$

In Fig. 39 above, the calculated and observed spectra are displayed so that a comparison of the order of agreement is possible.

It will be seen that the peculiarities of the iron pyrites spectra can be explained quantitatively, in

an approximate manner, as well as qualitatively. Though there are obvious discrepancies between theory and experiment, the analysis does in almost all cases indicate the reason for the observed absence of spectra, and so far as it does this it deserves to be called a quantitative analysis. If the vector diagram which we draw in order to find the resultant reflection of a complex arrangement of planes indicates that this resultant is zero in a certain case, and it is found by experiment that the corresponding spectrum is absent, this alone justifies some of the important assumptions we have made. We will now examine these assumptions in some detail.

When X-rays pass over an atom, the atom diffracts a portion of the energy in the wave train. A train of waves of the same wave length proceeds from the atom, which is executing forced vibrations. We have assumed in the calculations that when the trains from two neighbouring atoms interfere, their relative phases may be obtained by supposing the train diffracted at some geometrical centre of each atom. To obtain the phase difference, we compare the path difference of the two diffracted trains. Now there is no reason *ab initio* why there should not exist for each atom a special phase-lag, which would compel the addition of a distance t to the total path of any ray which it diffracted. The phase difference of the trains from two atoms might depend on their nature as well as on their relative positions. This would affect the intensity of the resultant train.

There is a case where this assumption can be tested directly and with considerable accuracy. In Fig. 50, Chapter IX., are given the spectra reflected from the faces (111) and $(\bar{1}\bar{1}\bar{1})$ of zincblende, that is to say, two opposite faces perpendicular to a trigonal axis of the crystal. The arrangement of the planes parallel to these faces has the polar nature displayed in Fig. 43 (*a*).

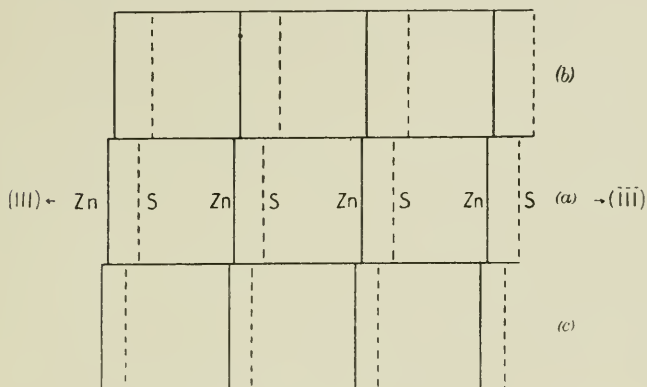

FIG. 43.

If there is a change of phase on reflection, corresponding to path differences t_1 and t_2 in the case of zinc and sulphur respectively, the wave train reflected from the faces (111) and $(\bar{1}\bar{1}\bar{1})$ will behave as if reflected without any phase change on the arrangements (*b*) and (*c*) of Fig. 43, respectively.

Given a phase change, we would therefore expect the spectra from the phase (111) to be different to the spectra from the face $(\bar{1}\bar{1}\bar{1})$. Reference to Fig. 50 will show that they are identical, thus

affording a direct proof that in this case the change of phase is the same for zinc and for sulphur. This is a sensitive test.

The next assumption made in the calculations regards the amplitude of the wave diffracted by each atom. The experimental evidence has been taken to indicate that this amplitude is proportional to the atomic weight. There would be a much firmer basis for this assumption if it could be tested for other series of compounds as well as the carbonates, but no such other series have as yet suggested themselves. How far the evidence given in this chapter justifies it, must be left to the reader.

We have good reason to believe both these assumptions are valid, for they stand on some experimental basis. They enable us to compare I_1, I_2, I_3 with I'_1, I'_2, I'_3 , as has been done above. It is a different matter to compute the relative values of I_1, I_2, I_3 , that is, the relative strengths of the spectra in any case, supposing the atoms all ranged in a series of identical equally spaced planes. There is much that is arbitrary in the assumption that the intensities bear a constant ratio

$$100 : 20 : 7 : 3 : 1.$$

It can only be justified in that it represents with fair accuracy the ratios when they are observable, and leads to calculations which are sufficiently satisfactory. The factors which enter into the relative strength of the spectra are at least three in number. We may take each as involving a fresh complication in the way of an additional factor of the relative

intensities of the spectra. In the first place, there is the simple problem which may be stated thus. Suppose we have an atom from which a wave, of the same amplitude in every direction, is diffracted when an incident wave passes over it. Suppose, further, that such atoms are arranged in a series of identical equally spaced planes. What will be the relative intensities of the spectra of different orders reflected from such a crystalline arrangement? This is a more or less definite mathematical problem. In solving it there are difficulties, for we know so little about the crystalline arrangement on a large scale. We cannot suppose a perfect relation of atom to atom to exist through the whole body of a crystal; the most cursory examination proves that no crystal, however perfect, attains so high a standard of perfection. A difficult question arises as to the range over which we suppose the perfect structure to persist. There is no reason, however, to despair of the solution of this problem.

We next require to know the 'scattering function' of the atom. It is exceedingly unlikely that the diffracted wavelet has the same amplitude all over, in fact, it may be taken to be an experimental fact that this is not so. The expression for the amplitude, at all points over a sphere, with the atom its centre, must contain a factor $\psi(\beta)$, where β is the angle between the diffracted and the incident ray direction. The form of this function is not known with any approach to exactness or generality, although it has been investigated in certain cases.

Finally, there is the effect of the heat vibration of the atoms. As has been shown, by Debye,* since the atoms in the crystal are displaced from the mean positions owing to their heat vibrations, the spectra will be affected. The general effect is to lessen the spectra of higher, as compared with those of lower, orders. This factor, again, needs investigation, as we have no idea of its value in the case of any series of crystals.

We may hope in the future to isolate and solve the questions of each of these factors separately. They combine at present to create much uncertainty as to the theoretical values for I_1 , I_2 , I_3 in any special case. Such experimental information as is available is discussed in Chapter XI. of this book.

To pass to the experimental uncertainties in determining the relative intensities of the spectra. The conditions are quite definite. A narrow beam of monochromatic X-rays falls on the face of a crystal, this face being, to all intents, of infinite depth and extent. It is reflected as spectra of the first, second, and third order, each at its own angle. We wish to compare in each case the fraction of the incident beam reflected. As a matter of fact, the procedure has been to obtain a curve showing the reflection at all angles, the collimator and chamber slits being set at some arbitrary width. The height of a 'peak' has then been measured, the height of the curve showing the general radiation in the immediate neighbourhood has been subtracted, and the result taken to measure

*P. Debye, *Verh. der Deut. Phys. Ges.*, XV. Jahrgang, No. 15, §678.

intensity of the reflected beam. That this procedure gives an approximation to the truth there can be no doubt, but it is open to many grave objections. The ordinates of curve are not quite proportional to the ionisation in the chamber, for no calibration of the electroscope in each case was made. The refinement would not have been justified by the condition of accuracy in other respects.

Considering all these difficulties, it is not surprising that the calculated and experimental results do not agree better. They agree well enough to justify the arguments based upon them. Since the experiments here described were made the difficulties of measurement have been largely overcome, and the work can be repeated with much more claim to accuracy.

CHAPTER IX.

THE RELATION BETWEEN CRYSTAL SYMMETRY AND THE ARRANGEMENT OF THE ATOMS.

IN the preceding chapters we have discussed the structures of a whole series of cubic crystals. Though all these crystals belong to the cubic system, they belong to different classes of the system. For instance, rock salt, fluor and diamond are believed to belong to the holohedral or ditesseral central class of the cubic system. Zincblende belongs to the ditesseral polar, pyrites to the tesseral central class, each class being defined by its peculiar elements of symmetry. It is interesting to trace the connection between the symmetry as displayed by the crystal as a whole and the arrangement of atoms revealed by the spectrometer analysis.

A diagram of the NaCl structure is given on p. 95. Among the axes, planes, and centres of symmetry are the following :

Every cube edge is a rotation axis of fourfold symmetry.

Every cube diagonal is a rotation axis* of threefold symmetry.

* A rotation axis is such that a simple rotation of $2\frac{\pi}{n}$ around this axis brings the structure into self-coincidence. It is called a rotation

The diagonals of the cube faces are rotation axes of twofold symmetry.

A plane of symmetry coincides with each cube face.

A plane of symmetry passes through opposite parallel edges of each cube.

A centre of symmetry lies at each cube corner.

If the structure on which the molecules are built possesses these elements of symmetry, they will also be possessed by the crystal as a whole. That is to say, the crystal of rock salt has as symmetry elements :

Three fourfold axes $[100]$.

Four threefold axes $[111]$.

Six twofold axes $[110]$.

Three symmetry planes $\{100\}$.

Six symmetry planes $\{110\}$.

A centre of symmetry.

This is the full complement which a cubic crystal can possess. A crystal which has these elements of symmetry is said to belong to the holohedral class.

Reference to the structure of fluor-spar, described on p. 107, will show that this crystal has the same elements of symmetry as rock salt. They coincide in every respect with regard to their symmetry axes and planes, these being in fact the axes and planes of the face-centred cubic lattice. In both these cases axis to distinguish it from a screw axis, which is such that a rotation of $2\frac{\pi}{n}$ round it and a movement along it are necessary to bring the structure to self-coincidence.

the structures assigned to them would indicate that the crystals belonged to the holohedral class, and this is also the class to which they have been assigned by crystallographic evidence.

Compare with this the structure of zincblende, which is repeated in Fig. 44, this time in plan. The black and white zinc atoms of that plan are situated,

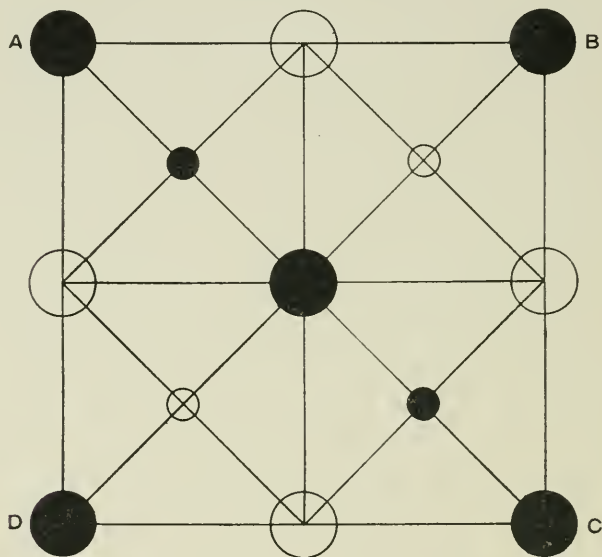

FIG. 44.

The large circles represent zinc atoms, the small circles sulphur atoms.
Blacks and whites of each size are in different planes.

so to speak, on the ground and first floors respectively, the whole plan representing two layers of cubes. It is the same with the sulphur atoms; the black atoms are at the centres of the lower layer of cubes, the whites at the centres of the upper layers. This plan will make it clear that there are planes of

symmetry perpendicular to the plane of the paper and cutting it in AC , BD . The crystal has therefore planes of symmetry parallel to (110) .

However, there are no planes of symmetry parallel to (100) . Such planes would cut the plane of the paper in lines parallel to AB and AD , and it is evident in the plan that this line and others parallel to it do *not* represent planes of symmetry.

Moreover, there are no axes of fourfold symmetry perpendicular to the plane of the paper in Fig. 44. Axes of merely twofold symmetry pass through cube centres and cube corners.

Considering the diagram in Fig. 30, Chap. VII., which represents the arrangement of the (111) planes in zincblende, there is another feature characteristic of its peculiar symmetry. The zinc and sulphur planes occur in pairs, which disposition gives 'polarity' to the axis of threefold symmetry perpendicular to these planes. If we proceed in one direction along the axis we meet first the zinc plane of each pair; proceeding in the opposite direction, the sulphur plane. Suppose that the crystal were building itself up in an octahedron, with (111) planes as faces, and that the ZnS molecules were depositing themselves on the growing faces in these pairs of planes. Two opposite faces of the octahedron would be different, one having a last layer of zinc atoms and the other of sulphur atoms. Half the faces of the octahedron would be of one kind, and the other half of another.

This is exactly what is observed in the case of an actual crystal of zincblende; it is the phenomenon

known as 'hemihedrism.' If a crystal of zincblende has octahedron faces, they are in general unequally developed. Half of them, which alone would make up a tetrahedron, are large, and the other half small. They are further to be distinguished by the action of solvents on them, which attack them in different ways. In some cases the faces of one kind alone are developed, so that, instead of a complete octahedron, the crystal has the shape of a tetrahedron. Further, if an insulated plate cut perpendicular to a threefold axis is touched with a heated metal, positive or negative electrification results according as a face of one kind or the other is touched.

Though the structure cannot explain the reason why one octahedron face develops more rapidly than the other, it explains why a difference between the faces is to be expected. The crystal structure is in accordance with the symmetry exhibited by the crystal as a whole.

Consider now the case of diamond, which is derived from the zincblende structure by substituting carbon atoms for both zinc and sulphur atoms. Its plan is represented in Fig. 45.

This structure at first sight appears to occupy a somewhat anomalous position. It possesses, of course, at least all the elements of symmetry of the zincblende structure. In this case, however, the $[111]$ axes are no longer polar, since the two planes of each pair are now alike. This polarity, which causes ZnS to be hemihedral, is now absent, and diamond must belong to the holohedral cubic class.

The crystal must have elements of symmetry which zincblende does not possess, namely, symmetry planes parallel to $\{100\}$, fourfold axes of symmetry, and a centre of symmetry.

A consideration of the structure in Fig. 45 shows that there are no reflection planes of symmetry or

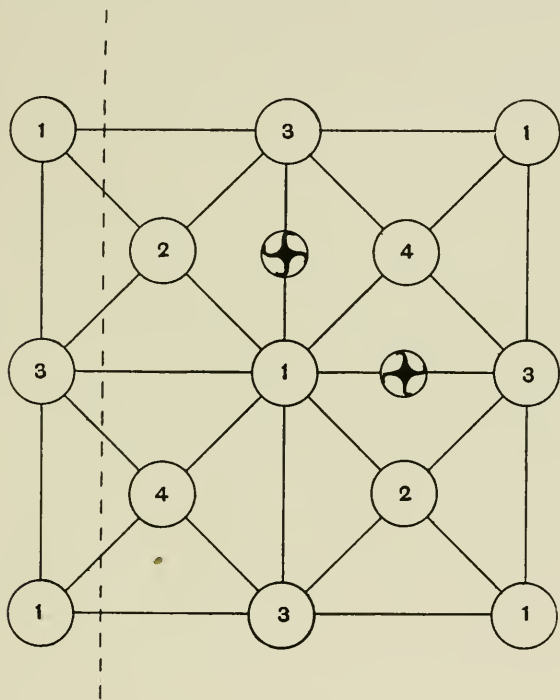

FIG. 45.

'rotation' axes of symmetry which could give rise to the holohedral symmetry of the crystal as a whole. Their places are taken by 'glide' planes of symmetry and 'screw' axes of symmetry. Two of the fourfold screw axes are marked in Fig. 45; it will be seen how

the points **1 2 3 4** are arranged in a spiral round the axis. The dotted line represents a plane of 'gliding reflection.' By its operation **1** turns into **2** and **3** into **4**. **1** is to be imagined reflected in the plane, at the same time receiving a translation which brings it to **2**.

If the structure has as elements of symmetry these screw axes and gliding planes, the crystal must have corresponding rotation axes and planes of symmetry. A rotation axis is, of course, the only kind which can be possessed by a crystal, for when the crystal is imagined turned round this axis through $2\frac{\pi}{n}$ into self-coincidence, its centre must remain fixed. The diamond crystal, according to the structure here put forward, is holohedral. There has been a great deal of controversy among crystallographers as to the class to which diamond should be assigned; on the whole the evidence has seemed to be in favour of the holohedral class, the alternative being the class to which zinblende belongs. However, even if the crystal really belongs to this latter class, the fact that the evidence for assigning it to this class is so doubtful, shows that its departure from holohedral symmetry must be very slight indeed. More will be said on this point in connection with cuprite and sylvine.

Iron pyrites, like zinblende, has a 'hemihedral' crystalline form. This hemihedrism is, however, of a different nature; pyrites belongs to the class known as 'tesseral central.' A cube of iron pyrites has

scratches or markings on its faces, and the scratches on each face are parallel to a cube edge and perpendicular to those of the neighbouring faces (see Fig. 46 *b*). This shows that the crystal does not possess a fourfold axis of symmetry perpendicular to the face, merely a twofold axis. The cube has a centre of symmetry, however, which distinguishes it from zincblende. It has planes of symmetry parallel to $\{100\}$, whereas in zincblende the planes of symmetry are

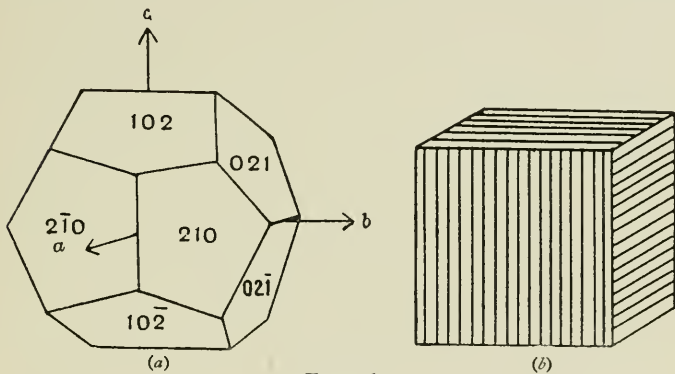

FIG. 46.
Iron Pyrites.

parallel to $\{110\}$. The crystals possess, in fact, all the elements of symmetry possessed by the cube in Fig. 46 (*b*), taking into account the markings on the face of that cube.

Fig. 47, p. 150, represents the structure of iron pyrites as assigned to it by our analysis. In Fig. 47 all the atoms of a unit cube are projected on one of the cube faces. It is at once evident that there is a reason why markings on the corresponding cube face of the crystal should go up and down, rather than

150 CRYSTAL SYMMETRY AND THE

from left to right, or *vice versa*. The sulphur atoms of the structure appear in pairs arranged vertically. This is only another way of saying that the structure, like the crystal, has twofold axes where a holohedral crystal would have fourfold axes. The twofold screw axes are marked in position in Fig. 47.

The dotted lines represent glide planes of symmetry. Every cube corner (see Fig. 41) is a centre

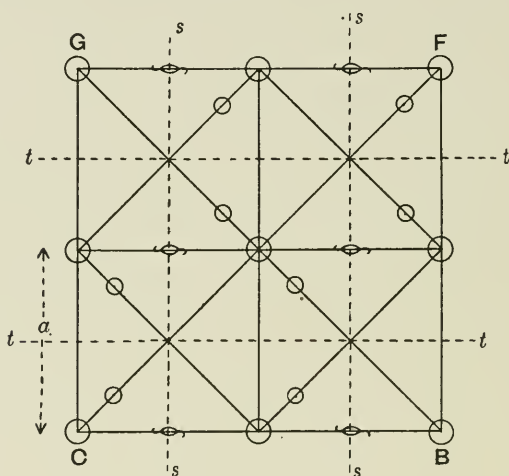

FIG. 47.

of symmetry. The non-intersecting threefold axes of symmetry have already been explained.

The structure of the crystal as revealed by the spectrometer is again in accordance with the symmetry exhibited by the crystal as a whole, so that the structure explains why the crystal develops a hemihedral form. The hemihedrism of pyrites betrays itself by forms such as that in Fig. 46 (a).

The cubic axes of the crystal are here drawn in position. It is perhaps clear that a holohedral crystal would have four faces surrounding each axis where it emerges from the crystal, for example $(2\bar{1}0)$, (210) , (201) , $(20\bar{1})$. Instead of this the faces $(2\bar{1}0)$, (210) alone appear, meeting in a line which is parallel to the scratches on the cube face.

This figure is a common form of iron pyrites, it is known as the pyritohedron in consequence.

The explanation of the difference between the

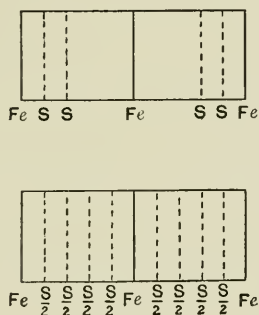

FIG. 48.

Upper diagram 210 planes.

Lower diagram 120 planes.

faces $\{210\}$ and $\{120\}$ cannot in this case be similar to the explanation of the hemihedrism of zincblende. There are no polar axes, for the crystal structure has centres of symmetry. But if we take the plan of the crystal structure as given in Fig. 41, and find the arrangement of the planes parallel to the faces (120) and (210) , the difference of these faces is accounted for. The arrangement of the planes is shown in Fig. 48.

The planes (210) and (120) have quite a different arrangement. In the one case the arrangement repeats itself at twice as great an interval as in the other case. That is to say, $d_{(210)}$ is twice as great as $d_{(120)}$.

This conclusion can be tested at once by cutting the two faces (120) and (210) on a cube of pyrites, and reflecting the X-rays from them. The results of this measurement are given in Fig. 49. The first reflection from the face (210) occurs at about 14° , that from the face (120) at about 28° . This measure-

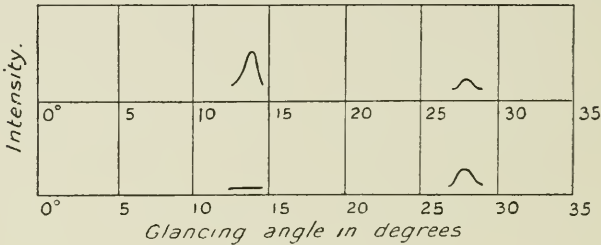

FIG. 49.

ment brings out an interesting fact, namely, that the face (210), which is commonly developed in pyrites crystals, is the face with the larger spacing $d_{(210)}$. The face (120) is much more rarely developed. One can remember how the structure of Figure 47 and an actual cube of pyrites must be placed so as to be similarly situated, by noting that the scratches on a pyrites face are parallel to the pairs of sulphur atoms observed when looking at the parallel face of the structure. Fig. 50 gives the spectra for the faces (111) and $(\bar{1}\bar{1}\bar{1})$ of a crystal of zincblende. These

are two opposite faces of an octahedron, one at each end of the polar axis of the crystal. As has been explained, such a pair of faces show the greatest difference in their development, etch-figures and pyro-electric properties, and on this account zincblende is referred to a hemihedral class of the cubic system. The X-ray spectra, on the other hand, do not distinguish between these two faces.

We have already discussed the significance of this

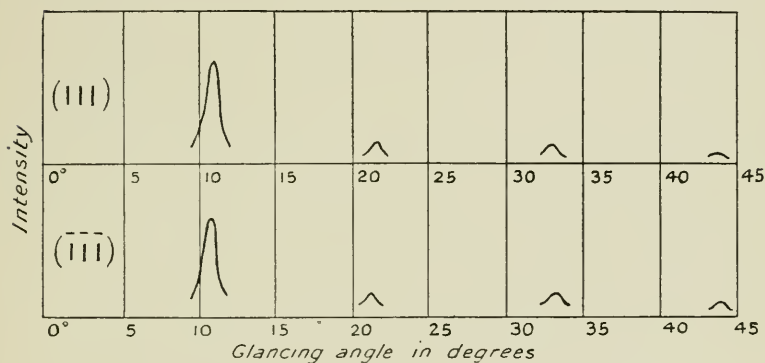

FIG. 50.

fact (Chap. VIII., p. 137). If it is true that the phase-lag on reflection is the same for all atoms, we may make a generalisation of this result. A pair of faces (hkl) and $(\bar{h}\bar{k}\bar{l})$ will always yield identical spectra when the X-ray is reflected on each face in turn. To put this in another way: when examining by the X-rays the faces of a crystal to find differences which might be due to the hemihedral nature of the crystal, all crystals will behave as if they had a centre of symmetry.

If a centre of symmetry were added to the elements of symmetry already possessed by zincblende, it would raise that crystal to the holohedral class. Therefore all Laue-photographs taken with zincblende will indicate a holohedral symmetry of the crystal, and in particular a photograph in which the incident rays are parallel to a cubic axis of the crystal will show a fourfold, as against a twofold, symmetry. On the other hand, the hemihedral iron pyrites already has a centre of symmetry. Adding a centre of symmetry does not raise it to the holohedral class, and we can therefore understand the fact that Laue-photographs of iron pyrites give unmistakable indications of its hemihedral nature.*

Very similar spectra are yielded by two crystals which belong to the same class as pyrites, namely Hauerite, MnS_2 , and Cobaltite, CoAsS . It is not easy to get such large crystals of these substances as those of iron pyrites, so that the reflections are very much weaker. They suffice to show, however, that all three crystals are built up in a similar way. About MnS_2 little need be said; it is natural that it should have the same structure and exhibit the same symmetry as iron pyrites.

The case of cobaltite is rather interesting. Cobalt replaces the iron, and arsenic atoms replace one-half the sulphur atoms in the pyrites structure. If this is carried out in a symmetrical way the structure loses

*This point has been dealt with very fully by G. Friedel (*Comptes Rendus*, Dec. 1913, p. 1533. See also W. L. Bragg (*Phys. Zeit.* 15 Jahr. 1914, Seite 77-79).

some of its elements of symmetry, for the trigonal axes become polar. The centres of symmetry at the cube corners of Fig. 41 are destroyed, for each has now an arsenic atom on one side and a sulphur atom on the other. The structure belongs to a still lower class of the cubic system, namely, the tesseral polar class. The typical crystal of the class is the mineral Ullmannite, NiSbS . This crystal has not

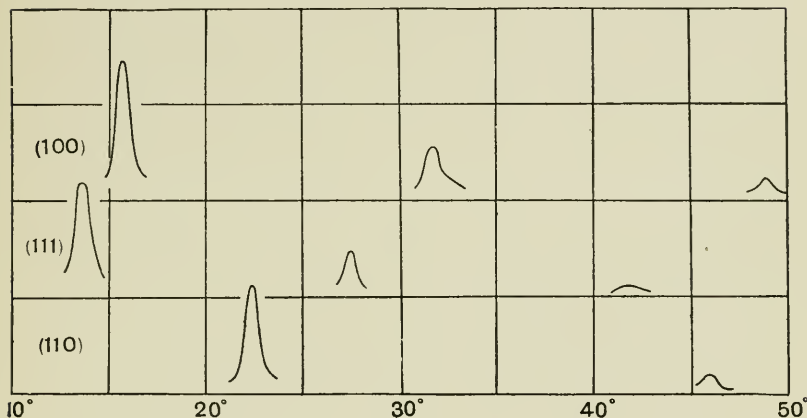

FIG. 51.
Cuprite spectra.

yet been examined, but it is natural to suppose that NiSbS and CoAsS belong to the same class.

There remains but one class of the cubic system of which we have not given a corresponding example in crystalline structure. This class is typified by Cuprite, Cu_2O . The crystals have no planes of symmetry and no centre of symmetry, but they possess the complete number of axes of symmetry of the cubic system. The class is known as the

holoaxial class, and crystals belonging to it have two enantio-morphous forms. They are either right- or left-handed.

The spectra and supposed structure of cuprite are shown in Figs. 51 and 52. The spectra are typical of the face-centred cubic lattice. There can be little doubt that the heavy copper atoms are arranged in a face-centred cubic lattice, the oxygen atoms being so

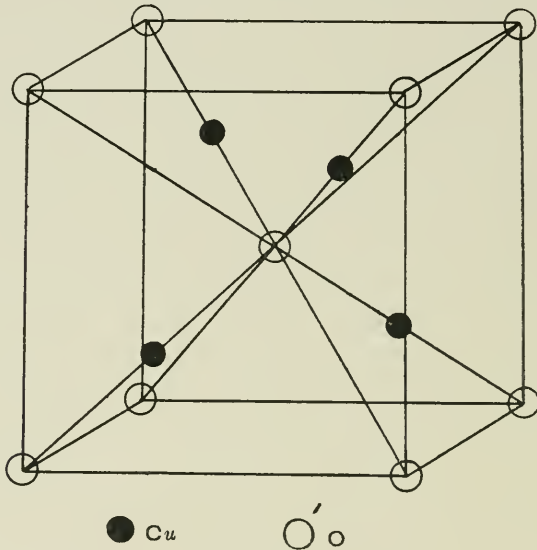

FIG. 52.

light that they make comparatively little difference to the intensities of the spectra. The absolute dimensions of the structure confirm this supposition. Taking the copper atoms to be on a face-centred lattice, the oxygen atoms must now be allotted to the structure in such a way that there are two atoms of

copper to one of oxygen. The most simple way of doing this leads to the construction shown in Fig. 52. The oxygen atoms lie on a cube-centred lattice, the copper atoms on a face-centred lattice, and the two intersect as shown.

This structure has holohedral symmetry. If the copper and oxygen atoms have these exact geometrical positions, the crystal of cuprite ought to exhibit holohedral symmetry. Instead of this, certain uncommon forms of the crystal show that its symmetry is in reality holoaxial. If this holoaxial symmetry corresponded to a large distortion of the holosymmetric structure, such as the distortion in the case of iron pyrites, which consists of a large displacement of the sulphur atoms, it is probable that the spectra would show the influence of this distortion. They would not be as straightforward as they are. The spectra alone indicate the holosymmetric structure given in Fig. 52. A very slight distortion of the structure would not affect the spectra, but might have sufficient influence on the growth of the crystal to account for the rare forms of cuprite which show holoaxial symmetry. On the other hand, the crystallographic evidence would seem to show that the distortion of the structure is slight. The etch figures of cuprite indicate a holosymmetric crystal, and the crystal does not rotate the plane of polarisation of light. It is only on account of the existence of crystals which show a holoaxial hemihedrism that cuprite is assigned to the holoaxial class.

These observations apply equally well to the case

of potassium chloride, which was the first example worked out in this book. Potassium chloride is assigned by crystallographers to the holoaxial class of the cubic system. We have seen that the examination by means of the X-ray spectrometer indicates the structure given in Fig. 28, which has perfect cubic symmetry. Any distortion of this structure must be slight, or the spectra would give evidence of it. When a potassium chloride crystal is etched with water, it displays facets $\{931\}$ in accordance with holoaxial symmetry, and on this evidence is assigned to the cuprite class. Again, however, there is no trace of rotatory polarisation.

Ammonium chloride is assigned to the holoaxial class on similar evidence, while the spectra give to this crystal a structure with holohedral symmetry. The chlorine atoms are arranged on a simple cubic lattice, the nitrogen atoms are at the centres of the cubes at the corners of which the chlorine atoms are situated. The arrangement of the hydrogen atoms is doubtful, as they are so light that they do not affect the X-rays. It is interesting to notice that ammonium chloride is in no sense isomorphous with the other alkaline haloids, although it also crystallises in the cubic system. Each unit cube of the structure contains in the one case half a molecule of KCl (see p. 109), in the other case a whole molecule of NH_4Cl .

This division of crystals into those in which the distortion from perfect symmetry is large, and those in which it is small may appear at first sight arbitrary,

but it is at any rate an interesting speculation. On the one hand, we have zincblende, pyrites, hauerite, cobaltite, etc., in which the symmetry of the crystal is obviously related to the symmetry of the structure. The distortion from holohedral symmetry is so large as to completely change the character of the spectra. On the other hand, we have cuprite, potassium chloride, and possibly diamond also, in which the spectrometer gives a structure which is of higher symmetry than that assigned to the crystal by crystallographic evidence. The departure of the first set of crystals from holohedral symmetry is very obvious, while it is on very slight evidence that the second set is believed to depart from the class of higher symmetry.

CHAPTER X.

THE ANALYSIS OF CRYSTALS. PART III.

IN the last two chapters we have considered crystals whose structures could be elucidated with some approach to completeness. In this chapter several instances will be given of crystals whose precise arrangement is not yet known, although the results obtained in their investigation are so interesting as to warrant their mention. A great deal about the structure can be learnt by studying the spectra in each case.

*Quartz.** The symmetry of quartz is that described as 'trigonal holoaxial.' Fig. 53 shows a right-handed crystal of quartz. It will be seen that three edges meet in the apex of the crystal, these edges being parallel to the axes to which the crystal is referred. The faces marked R are the faces $\{100\}$, z is $\{2\bar{1}2\}$, m $\{2\bar{1}\bar{1}\}$. Quartz is thus referred to three equal axes making equal angles with each other, just as is calcite. Quartz,

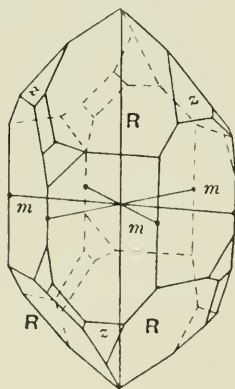

FIG. 53.

* See W. H. Bragg, *Proc. Roy. Soc., A*, Vol. 89, p. 575.

however, unlike calcite, possesses neither planes nor centre of symmetry, having axes of symmetry alone. There is a single axis of three-fold symmetry, with three axes of twofold symmetry intersecting in it, these being shown in the figure. Because quartz has no centre or plane of symmetry,



FIG. 54.

it follows that the crystals may be of two kinds, right- and left-handed, these kinds being related to each other as are an object and its image in a mirror.

The spectra yielded by various faces of quartz are given in Fig. 54.

This crystal is more complicated than any as yet measured, and it is somewhat difficult to express

these results in terms of the crystal structure. This becomes more simple if we give up the axes to which quartz is generally referred by crystallographers, and employ a set of hexagonal axes. For our purpose it is more convenient to refer quartz to a hexagonal space lattice.

An example of the rhombohedral lattice has already been given in the case of calcite, where the atoms of calcium, or those of carbon, are arranged on such a lattice. There is another type of lattice which is always at the base of crystals with hexagonal symmetry, and which may be also at the base of crystals with trigonal symmetry. This is the hexagonal lattice shown in Fig. 55. We know that all crystals of trigonal symmetry must have either this lattice or the rhombohedral lattice as their basis, and we shall see that, in the case of quartz, it is the hexagonal lattice which gives the simplest explanation of the observed spectra. For instance, the first order spectrum occurring at the smallest angle is that from the plane $(2\bar{1}\bar{1})$, so that these planes are further apart than any others in the crystal. The planes $\{2\bar{1}\bar{1}\}$ form the sides of the usual six-sided prism of quartz. But the planes $\{2\bar{1}\bar{1}\}$ are very unlikely to be the most important in the case of a rhombohedral lattice. In the case of calcite, for instance, the first reflection from $\{2\bar{1}\bar{1}\}$ occurs at 24° , the first (100) at 11° , the first (111) at 11.2° . Contrasted with this, we have for quartz the first $(2\bar{1}\bar{1})$ at 7.8° , the first (100) at 10° , the first (111) at 18.5° . This is at once explained on referring

quartz to a hexagonal lattice, for then the prism faces rank high in importance, and we would expect to get the reflection from them at a small angle.

The typical crystal of quartz consists of a six-sided prism terminated, if perfect, by a six-sided pyramid

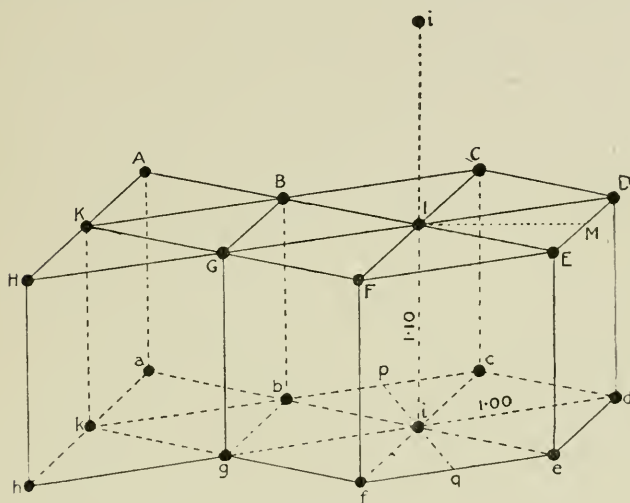

FIG. 55.

at each end. Some of the corners are generally modified by small faces of other types (Fig. 53). We will suppose that the underlying lattice is such that the prism faces are parallel to $EDde$, etc., the pyramid faces to Ide . The length ID is called ' a ,' the height Ii , ' c .' Measurement of the quartz crystal shows that

$$a : c = 1 : 1.10.$$

With each point of the lattice there is associated a volume $\frac{a^2\sqrt{3}}{2} \cdot c$. If this lattice really underlies the

quartz structure, we must find the number of SiO_2 atoms associated with each point of it, in the way that we have always done for other crystals.

We will take the distance a , as determined by the first spectrum of the prism face. We have

$$2 \cdot \frac{a\sqrt{3}}{2} \cdot \sin 3.9^\circ = 0.576 \times 10^{-8},$$

$$a = 4.89 \times 10^{-8} \text{ cm.}$$

Therefore the mass contained in unit cell of the lattice (density of quartz = 2.65) is equal to

$$2.65 \times a^3 \times 1.1 \times \frac{\sqrt{3}}{2} \text{ grams}$$

$$= 2.94 \times 10^{-22} \text{ grams.}$$

The mass of one molecule of SiO_2 is

$$(28.3 + 32) \times 1.64 \times 10^{-24} \text{ grams} = 0.99 \times 10^{-22} \text{ grams,}$$

and a comparison of the above quantities shows that *three* molecules of SiO_2 are associated with each point of the lattice we have chosen. Using this fact, we can proceed to an exact numerical calculation of the spacings parallel to various faces of the crystal, and so of the angles at which we may expect a first spectrum. We take for granted the association of three SiO_2 molecules with each point of the lattice, and carry out for each face the reverse of the above calculation. The agreement between theory and experiment is shown in the table opposite.

PLANE.	INDICES.	GLANCING ANGLE OBSERVED.	GLANCING ANGLE CALCULATED.
Prism $EDde$	$(2\bar{1}\bar{1})$ or $(10\bar{1}0)$	3.9°	3.9°
Pyramid Ide	(100) $(2\bar{1}\bar{2})$ or $(10\bar{1}1)$	4.93°	4.95°
$FDdf$	$(1\bar{1}0)$ or $(\bar{1}2\bar{1}0)$	6.60°	6.75°
Gpq	$(\bar{1}2\bar{1}1)$	9.2°	9.1°
$I'de$	$(20\bar{2}1)$	8.4°	8.3°
$BGed$	$(10\bar{1}2)$	7.25°	7.3°
$AHed$	$(10\bar{1}3)$	10.15°	9.5°
Basal plane $BCDEFG$	(111) or (0001)	9.25°	3.1°

We see that in every case the calculated and observed angles agree, except in the case of the basal plane $\{111\}$ or $\{0001\}$. Here the observed angle of reflection is three times larger than the calculated angle, and so the spacing of the planes three times smaller than that of the underlying lattice. Bearing in mind the fact that three SiO_2 molecules are associated with each point of the lattice, the significance of this last angle becomes clear. The quartz structure is based on three interpenetrating hexagonal lattices. These are so related that they can be derived from each other by a rotation of $\frac{2\pi}{3}$ about, and a translation $\frac{c}{3}$ along, an axis parallel to the c direction. Thus each trigonal axis of the structure has points arranged spirally around it, and since a spiral may be either right- or left-handed, we can understand the reason for the two forms of quartz.

What will be the effect of this on the positions of the first order spectra? We may call the points belonging to the three lattices p_1, p_2, p_3 . Three points,

p_1, p_2, p_3 , form one turn of a spiral. All the points of one kind, such as p_1 , lie on a hexagonal lattice of such dimensions that it alone would give the first orders at the calculated angles of the table on p. 165. Add now to this structure the points p_2 and p_3 . A little consideration will show that in general the distance $d_{(hkl)}$

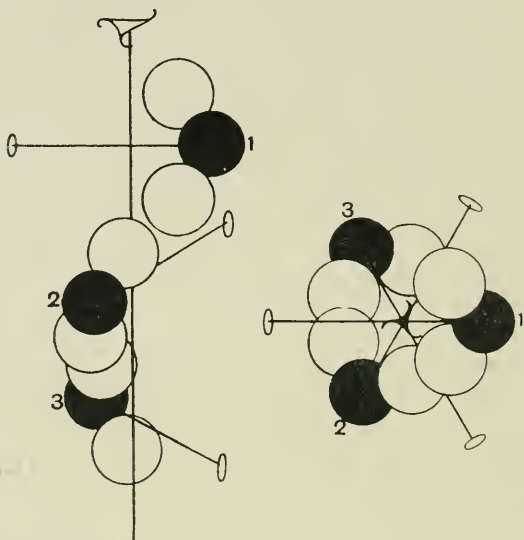

FIG. 56.

for any face of the crystal is not diminished by the addition of these lattices, their only effect is to make the arrangement of planes more complicated. One plane only is an exception to this rule, the basal (111). Since the points p_2, p_3 are derived from p_1 by successive translations of $\frac{c}{3}$ perpendicular to (111), the distance $d_{(111)}$ will be divided exactly into

three by the new planes. The anomalous angle of reflection from these plans is explained.

In order to find the precise disposition of the atoms, we must rely on the peculiarities of the spectra from each face. Fig. 56 represents the most general possible arrangement of atoms. The three atoms forming a molecule SiO_2 will be recognised in this diagram. We have here a trigonal axis with three digonal axes intersecting it. The typical silicon atom must lie on one of these digonal axes, but may lie at any distance from the trigonal axis. The oxygen atom may lie anywhere, but must have a fellow which is opposite to it across the digonal axis. Thus three coordinates are required to place the oxygen atoms, making four in all which determine the crystal structure. In order to determine these four unknowns we shall have to improve our knowledge of the mechanism of reflection, and our methods of determining the strength of spectra.

*Sulphur.** The case of sulphur is somewhat similar. This element in its common form is orthorhombic, with axial ratios $a : b : c = 0,811 : 1 : 1,901$. The angles of reflection from various faces of the crystal are given in the table below.

Plane - - - -	100	010	001	011	101	110	111
Glancing angle { Calculated -	6.35	5.2	1.33	5.85	6.82	4.06	4.3
{ Observed -	6.2	5.15	10.5	59	7.0	4.07	4.15

With the exception of the plane (001), the angles of reflection from the various faces are those to be

* See W. H. Bragg, *Proc. Roy. Soc., A*, Vol. 89, p. 575.

expected from a lattice of the form and dimensions shown in Fig. 57. On calculating the number of sulphur atoms to be associated with each point of the lattice, this comes to be eight, and this number was assumed when the upper set of angles in the table were worked out. In correspondence with

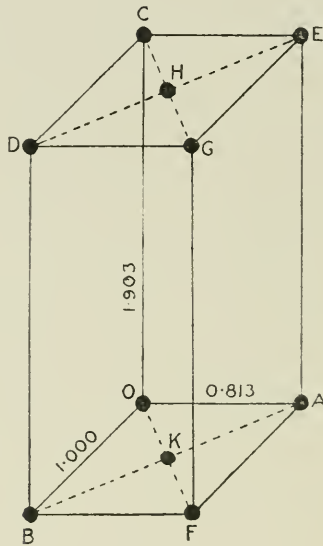

FIG. 57.

this, the plane (001) has a glancing angle just eight times greater, and so a spacing just eight times smaller, than that of the lattice. Obviously there are eight interpenetrating lattices, as there are three in quartz, and these lattices are evenly spaced along the c direction.

So far only one spectrum has been found reflected from each face of sulphur, so that no clue to its

structure is yielded. It possesses, however, one interesting feature. Let us call the lattices P_1, P_2, \dots, P_8 . The points of all these eight lattices cannot be similar in their situations, as will be seen if the reader tries to picture their distribution about the axes of the structure.

We can at most have all the points of P_1, P_2, P_3, P_4 similarly situated to each other and forming a set contrasted in disposition with the remaining points P_5, P_6, P_7, P_8 , which latter are again similarly situated in all respects. There are, in other words, sulphur atoms of two kinds in the crystal. It may even be that there are sulphur atoms of four or eight kinds, but at all events they are not all identical. There must be some connection between this complexity and the fact that sulphur forms molecules containing a large number of atoms (six to eight) in its vaporous state near the boiling point.

Haematite and Ruby. Haematite, Fe_2O_3 , and Ruby, Al_2O_3 , are two crystals isomorphous with each other and belonging to the same crystal class as calcite, CaCO_3 . The spectra of these crystals indicate a simple structure, but one which cannot be so completely evaluated as can that of calcite. We may arrive at it as follows.

Take the calcite structure of Fig. 36 in the eighth chapter, and suppose the oxygen atoms to be marshalled as they are in that crystal. Picture the carbon atoms removed, and each calcium atom replaced by two aluminium atoms, arranged dumbbell-wise parallel to the c axis. It is easy to see that the

proportion of atoms will be that of the molecules Al_2O_3 . The structure has two variable quantities. The first determines the position of the oxygen atom, exactly as in calcite, and may be again defined as the ratio $\frac{x}{d}$ (Fig. 36B). The second variable is the distance between the aluminium atoms of a pair. Precisely the same considerations lead us to this marshalling as in the case of calcite.

If we examine the planes $(1\bar{1}0)$, which are parallel to the trigonal axis, the second variable does not enter into consideration. These planes have the first and second spectra nearly equal, the third and fourth too small to observe. This would indicate that the ratio $\frac{x}{d}$ is approximately $\frac{1}{2}$, giving an arrangement of planes $\text{Al}_2\text{O} \dots \text{O}_2 \dots \text{Al}_2\text{O} \dots \text{O}_2 \dots \text{Al}_2\text{O}$ and so accounting for the large second spectrum. Next, when we examine the planes (111) , the value of $\frac{x}{d}$ does not affect the arrangement of these planes, which have the arrangement

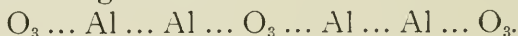

As the second and third spectra are stronger than the first spectrum, it is probable that the distance $\text{Al} \dots \text{Al}$ is somewhat smaller than the distance $\text{Al} \dots \text{O}_3$.

The $(1\bar{1}0)$ and (111) spectra can be equally well explained, however, by supposing the pair of aluminium atoms to be centred about the points where the carbon atoms are in calcite, leading to

a slightly different marshalling. It will be seen by this example how very much more difficult it is to determine a structure with two variables, like ruby, than a structure with one variable, like calcite. The spectra of ruby and haematite are given in the table below. The angles are those of the ionisation chamber, the numbers represent the intensities of the spectra.

RUBY.

Plane.	1st.	2nd.	3rd.	4th.
(100)	9.5° 53	19.2° 113	29.2° 14	39.3° 23
(111)	15.3° 19	31.2° 57	47.8° 35	
(110)	14.1° 32	28.7° 30	0	0

HAEMATITE.

(100)	9.4° 19	18.7° 75	27.9° 10	37.5° 12
(111)	14.8° 13	0?	45° 14	

The Spinel Group. The spectra of three crystals of the spinel group, given in Fig. 58, will show how closely these crystals are related in their structure. The spinels are all cubic, and have the formula $R''R_2'''O_4$, when the divalent metal R'' may be Mg, Fe, Zn, or Mn, and the trivalent metal R''' may be Fe, Mn, Cr, Al. Magnetite, Fe_3O_4 , belongs to this

group. The unit cube of the structure can be shown to contain one molecule $R''R_2'''O_4$, and the spectra are peculiar in that the planes (110) are apparently the most widely spaced of all those in the crystal.

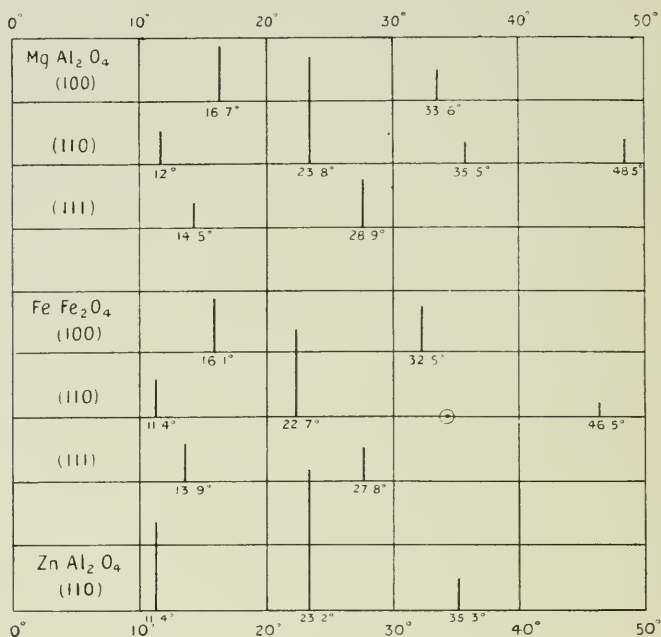

FIG. 58.

Appended to this chapter is a list of the crystals whose structure has already been examined by the X-ray spectrometer. The crystals of class A have been worked out with some completeness. For those of list B we know the marshalling but not the precise arrangement of the atoms. In the case of those of list C, little more than the number of molecules in each unit of the structure is known.

A.

CRYSTAL.	SYSTEM.	REMARKS.
Diamond, C	cubic.	
Copper, Cu	"	Atoms of Cu on face-centred cubic lattice.
{ Sodium chloride, NaCl	"	
{ Potassium chloride, KCl	"	
{ Potassium bromide, KBr	"	
{ Potassium iodide, KI	"	
Galena, PbS	"	Pb and S as Na and Clin sodium chloride.
Zincblende, ZnS	"	
Zincite, ZnO	hexagonal.	} Two interpenetrating hexagonal lattices.
Cadmium sulphide, CdS	"	
Fluor, CaF ₂	cubic.	
{ Pyrites, FeS ₂	"	
{ Hauerite, MnS ₂	"	
{ Sodium nitrate, NaNO ₃	rhombohedral.	
{ Calcite, CaCO ₃	"	
{ Dolomite, CaMg(CO ₃) ₂	"	
{ Rhodochrosite, MnCO ₃	"	
{ Chalybite, FeCO ₃	"	

B.

CRYSTAL.	SYSTEM.	REMARKS.
{ Aragonite, CaCO ₃	orthorhombic.	Pseudo-hexagonal assemblage, closely related to calcite, CaCO ₃ .
{ Cerussite, PbCO ₃	"	
{ Potassium nitrate, KNO ₃	"	
Ammonium chloride, NH ₄ Cl	cubic.	Position of H atoms uncertain.
Cobaltite, CoAsS	"	Belongs to pyrites group.
Sodium chlorate, NaClO ₃	"	Sodium and chlorine atoms approximately as in sodium chloride.
Cuprite, Cu ₂ O	"	
{ Haematite, Fe ₂ O ₃	rhombohedral.	
{ Ruby, Al ₂ O ₃	"	

CRYSTAL.		C.		SYSTEM.	REMARKS.
Quartz, SiO_2	rhombohedral.	
Sulphur, S	orthorhombic.	
{	Spinel, MgAl_2O_4	cubic.	
	Magnetite, FeFe_2O_4	"	
	Gahnite, ZnAl_2O_4	"	
Graphite, C	pseudo-hexagonal.	One measurement only, on cleavage basal plane $d = 3.42 \cdot 10^{-8}$ cm.

CHAPTER XI.

THE INTENSITY OF X-RAY REFLECTION.

THE efficiency of reflection of X-rays depends on a number of factors, such as the absorption coefficient of the rays in the crystal, the arrangement of reflecting planes, the distribution of weight among the planes, the magnitude of the glancing angle, and the thermal movements of the atoms of the crystal. In this chapter we propose to consider the various factors separately, so far as such division is possible and as our present imperfect knowledge permits.

We have already considered in Chapter IV. the relation between the quality of the X-ray and its absorption by various substances. The quality was then defined by reference to the nature of the radiator which emitted rays of the given quality as its secondary radiation. We can now measure with accuracy the wave length of the X-ray, and it becomes a matter of importance, particularly for our present purpose, that the quality should be expressed in terms of wave length. The comparison which we obtain in this way is entirely quantitative, and all the quantities involved can be measured with precision. The radiation, which was formerly described as the

homogeneous radiation characteristic of a given substance, is now found to be complex, and to consist of two or more constituents, which may be submitted to separate examination. It will be well to consider first what has been done towards a redetermination of absorption coefficients in the more precise terms which are now at our command.

The experiment consists in reflecting a certain homogeneous constituent of X-radiation and observing the result of interposing various screens. We may anticipate that this will be done eventually for a great variety of wave lengths and of absorbers. The work has already been begun, but will take some time to complete. The results of a preliminary survey by Mr. S. E. Peirce are given in the following table, in which, perhaps, the most striking feature is the considerable difference between the absorption coefficients of the different constituents of the radiations from one and the same substance. For example, the absorption coefficients in aluminium of the two constituent radiations from silver are 1.94 and 2.70 respectively. The coefficient found by Barkla, 2.5, is clearly a mean between these two, as might be expected.

The figures in the first six rows of the table were measured with considerable care, and were as accurate as could well be obtained from the instrument employed. The results for platinum rays are less exact, but seem worthy of inclusion. The method was to place absorbing screens across the homogeneous rays reflected by a crystal, and to observe the change in

A.
 MASS ABSORPTION COEFFICIENTS (K).

Anticathode and ray.	Wave Length $\lambda \times 10^8$	ABSORBING ELEMENT.									
		Al.	Fe.	Ni.	Cu.	Zn.	Pd.	Ag.	Sn.	Pt.	Au.
Silver β -	.491	1.94	14.2	17.8	20.9	21.8	58+	10.3	12.2	46.9	48.0
Palladium " -	.508	2.25	17.7	21.6	22.4	25.0	11.4	12.4	15.2	52.3	58.0
Rhodium " -	.537	2.73	19.3	23.4	25.3	28.1	12.8	14.0	16.7	55.1	57.7
Silver α -	.554	2.70	20.4	25.0	26.7	30.3	13.6	14.3	18.1	64.1	65.8
Palladium " -	.576	3.16	23.1	28.9	30.9	34.0	16.2	16.9	20.0	74.4	75.4
Rhodium " -	.615	3.53	26.0	32.1	34.6	38.8	18.0	19.8	23.3	75.9	78.5
Platinum C -	.95	11.4	80	—	115	—	—	71.8	78	—	—
" B -	1.10	20.8	125	167	186	—	—	86	107	92	98
" A -	1.32	30.8	205	250	273	39.1	—	152.5	—	145	—
Atomic numbers -		13	26	28	29	30	46	47	50	79	80

178 INTENSITY OF X-RAY REFLECTION

the ionisation current. There are certain difficulties in the way of obtaining accurate results by this method, due chiefly to the irregularities of the source of X-rays. Measurements of intensity are far more difficult than measurements of angle of reflection, chiefly from this cause. It becomes desirable to employ a balance method. In a further and more complete determination of absorption coefficients which is now in progress, two portions of the same homogeneous radiation are reflected by two rock-salt crystals into separate ionisation chambers, the two currents being made to balance by the interposition of suitable screens. The method is a null one, the electroscope being no more than a detector of a want of balance.

Meanwhile the figures in Peirce's table show some features of decided interest. In a second form of the table, the absorption coefficients are calculated in terms of the weight of the absorbing atom, the figures in the first table having been multiplied by the weight of the atom. A figure from the first table, such as 20.4, the absorption coefficient of the longer silver wave in iron, means that a pencil of these rays crossing a layer of iron one centimetre square and weighing x grammes would lose a fraction of their energy equal to $20.4 \times x$. Of course this is only true when $20.4 \times x$ is a very small fraction. In the second table, the corresponding coefficient 18.71×10^{-22} is the fraction of the energy of the same pencil of rays, one square centimetre in section, which would be absorbed in passing over one iron atom.

B.
 ABSORPTION PER ATOM (K, α) $\times 10^{22}$.

Anticathode and ray.	Wave Length $\lambda \times 10^8$	ABSORBING ELEMENT AND ATOMIC NUMBERS.									
		Al. 13	Fe. 26	Ni. 28	Cu. 29	Zn. 30	Pd. 46	Ag. 47	Sn. 50	Pt. 79	Au. 80
Silver β - -	.491	.86	13.0	17.2	21.8	23.4	101.5?	18.2	23.8	150	155
Palladium ,, - -	.508	1.00	16.2	20.8	23.4	26.8	20.0	22.0	29.7	167	188
Rhodium ,, - -	.537	1.22	17.7	22.6	26.4	30.1	22.4	24.8	32.6	176	187
Silver α - -	.554	1.20	18.7	24.1	27.8	32.4	23.8	25.3	35.4	205	213
Palladium ,, - -	.576	1.41	21.4	27.9	32.2	36.4	28.3	30.0	39.0	238	244
Rhodium ,, - -	.615	1.57	23.8	30.9	36.1	41.6	31.5	35.1	45.5	243	254
Mass of atoms -	$A \times 10^{24}$	44.5	91.6	96.4	104.3	107.1	175.0	177.0	195.2	320.3	323.5

180 INTENSITY OF X-RAY REFLECTION

When the logarithms of the coefficients for any one absorber are plotted against the logarithms of the corresponding wave lengths, a straight line is obtained, the slope of which implies that the absorption is proportional to the wave length raised to the power $5/2$. The platinum figures do not fit in very well ; but under the circumstances it will be well to wait for further experiment before discussing the fact. Owen found* that the absorption coefficient of a radiation was inversely proportional to the fifth power of the atomic weight of the radiator. This is easily seen to be the same law, because the wave length is approximately proportional to the inverse square of the atomic weight.

When the logarithms of the coefficients for any one wave length are plotted against the logarithms of the atomic numbers of the absorbers a second series of straight lines are obtained, which are shown in Fig. 59. The slope of these lines shows that the absorption varies very nearly with the fourth power of the atomic number ; but the constant of the proportion changes as one of the critical values is passed through. Both propositions may be summed up in the statement that the atomic absorption coefficient, viz. Kw , where w is the actual weight of the atom, K being the ordinary "mass absorption coefficient"

$$= CN^4\lambda^{5/2}.$$

The value of the constant C is about 1.79×10^{-6} on one side of the critical point for each wave length,

**Proc. Roy. Soc.*, 1912, p. 426.

and $c.235 \times 10^{-6}$ on the other: the ratio of the two values being nearly 8 to 1, a relation which has been noticed before (p. 44).

The series of absorption coefficients of the platinum rays pass through two critical points: the few values obtained by Peirce—values which are of the same

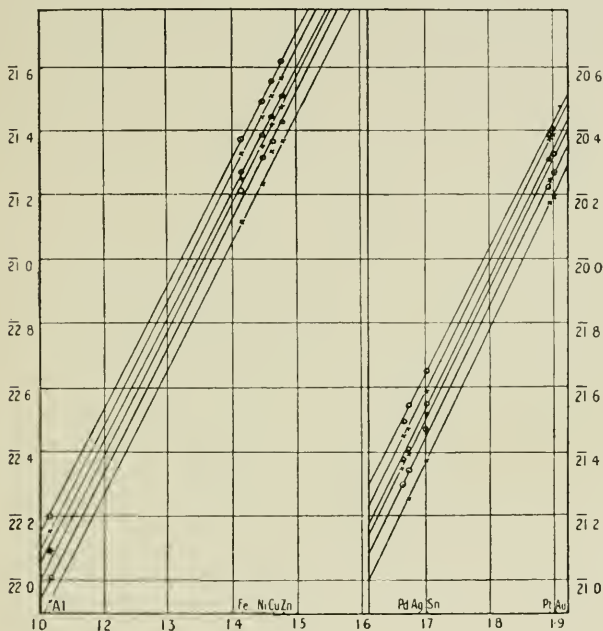

FIG. 59.

order as have been found by the older methods— seem to show that the constant experiences another drop in the ratio 4 to 1.

It may be noticed that the critical value of the wave length when palladium is the absorber lies between the two wave lengths emitted by silver. The high absorption of the shorter wave could not

be measured accurately with the palladium foil available, as its thickness was too great.

Apart from this direct attack upon the absorption question there are certain indirect methods which give very interesting information respecting particular features of the problem, and have a direct bearing on the subject of this chapter. We have already mentioned (p. 43) the existence of certain critical points in the relation between quality of X-ray and atomic weight of absorbing screen. The existence of these discontinuities is made manifest in several striking ways.

It will be remembered that a given atom absorbs on a much higher scale the X-rays characteristic of atoms heavier than itself than the X-rays characteristic of lighter atoms. To put it in another way, an atom emitting homogeneous rays of wave length λ , absorbs rays of *shorter* wave length to a greater degree than waves of length equal to or greater than λ . There is no "absorption band" or "selective absorption" or "selective transparency" in the ordinary sense. The function, whatever it may be, which represents the relation between absorption coefficient and wave length in the case of a given absorber does not undergo a *temporary* aberration when the wave length passes through any value such as that of the radiation characteristic of that absorber. On the other hand, it experiences a violent *permanent* change when it passes through a value somewhat less than that of the wave length (or lengths) characteristic of the absorber.

In Fig. 60* are shown three curves, all representing the same portion of the spectrum of Pt rays given by NaCl (100). The peak shown is that of the longest wave length which is characteristic of platinum, viz. 1.316×10^{-8} cm. In the case of (a) no absorbing screen has been used; in the case of (c) a thin sheet of zinc has been interposed, and the radiations of the peak are seen to be reduced in

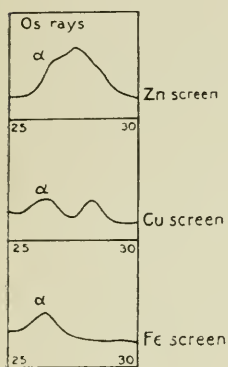

FIG. 61.

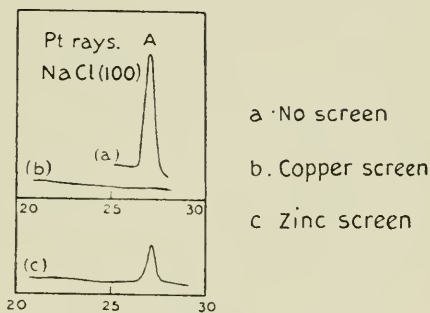

FIG. 60.

intensity. But when a thin sheet of copper of nearly equal weight is interposed—curve (b)—the radiation of the peak is completely absorbed. Now the characteristic rays of zinc have wave lengths 1.445×10^{-8} and 1.306×10^{-8} (Moseley). Those of copper are 1.549×10^{-8} and 1.402×10^{-8} .

These results may be compared with those which are represented in Fig. 61. In this case a portion of the osmium spectrum in NaCl (100) has been

* *Proc. Roy. Soc.*, 89, p. 43.

measured after the interposition of Zn, Cu and Fe screens respectively. The peak marked (a) is really a second order reflection of a short wave length 0.63×10^{-8} approximately, and represents a very penetrating radiation, which is not to be considered for our present purpose. The point is that the copper screen has removed a radiation at 27° as in the former case, and transmitted a radiation at 28.5° for which $\lambda = 1.38 \times 10^{-8}$. Both these rays are absorbed by iron.

These results may be summed up in the follow-

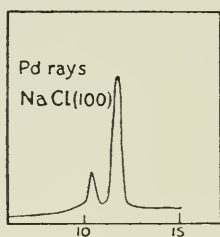

FIG. 62.

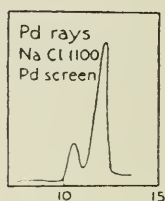

FIG. 63.

ing way. Copper, having characteristic waves 1.549×10^{-8} and 1.402×10^{-8} , has a critical absorption value at about 1.35×10^{-8} , transmitting greater wave lengths and absorbing lesser. Zinc should have a critical value at about 1.25×10^{-8} . In fact, as we shall see presently, it strongly absorbs the 'B' lines of platinum, 1.113 and 1.095×10^{-8} cm. respectively.

The same point is clearly shown by a comparison of Figs. 62 and 63, representing the radiation from palladium. In the second figure a piece of palladium foil has been inserted as an absorbing screen, with the result that the rays having wave lengths less

than the smaller of the two Pd rays have been strongly absorbed.

A variation of the same effect is observed as the result of the presence of various substances in the crystal itself. A wide-slit spectrum of the Pt rays in rock salt (100) is given in Fig. 64 (*a*). The ratio of the intensities of the three reflected pencils is found to be nearly the same, no matter what crystal is used, so long as the latter contains no atom with respect to which two of the radiations lie on opposite sides of the critical value. Diamond, quartz, calcite, sodium bromide, and many other crystals give a platinum ray spectrum of the same form. But if we use zinblende the form changes. For the critical wave length of zinc is about 1.25×10^{-8} cm., as we have seen above, and this falls between the wave lengths of the *A* and *B* peaks, which are 1.316 and 1.1×10^{-8} cm. respectively. The curve (*c*) in the figure shows how the peaks at *B* and *C* are reduced relatively to *A* by the action of the Zn atom. The critical wave length of arsenic must be a little less than the smaller of its two characteristic wave lengths, which may be calculated to be 1.08×10^{-8} . We may perhaps put it at 1.04×10^{-8} by comparison with the case of copper worked out above. We should therefore expect a crystal containing arsenic to reflect very little of the *C* peak of the platinum of wave length 0.95×10^{-8} nearly, as compared with the *B* peak of wave length 1.1×10^{-8} cm. nearly. The curve Fig. 64 (*b*) shows that this is the case, the reflection having been obtained from sodium arsenate.

It is possible to make quantitative measurements of these alterations. Mr. S. E. Peirce has kindly compared for us the intensities of the *A* and *B* peaks of platinum both for rock salt and zinblende. When the former crystal was used as reflector the ratio of intensities of *A* and *B* was 1.63, with the

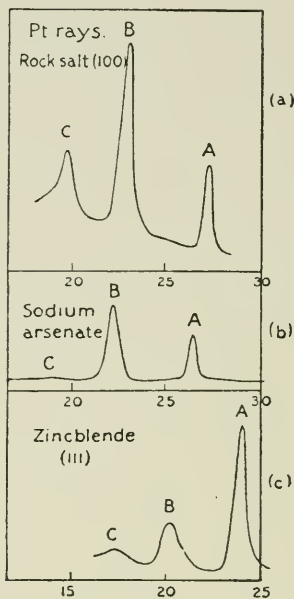

FIG. 64.

latter .464. Thus the ratio is increased $1.63/.464$, or 3.5 times by the use of zinblende. Accurate measurements of the absorption coefficients of the *A* and *B* peaks in zinc, sulphur, chlorine and sodium have not yet been made; but we can obtain approximate values by interpolation. In this way we find that the absorption coefficients of the *A* peak in zinc-

blende and rock salt are nearly 49 and 50 respectively, while the absorption coefficients of the *B* peak are 129 and 30. If differences of absorption were alone the cause of the change in the relative intensities of the *A* and *B* peaks when we replace one crystal by the other, we should therefore expect the magnitude of the change to be $129 \times 50 / 49 \times 30$, or rather more than 4 : 1. This is not far from the value found by Peirce. -

All these experiments go to show that the absorption coefficient has a direct influence upon the intensity of the reflection. We might state our conclusion in the form that other things being the same the intensity of reflection is directly proportional to the amount of mass traversed by the primary rays : it is a "mass effect."

We now proceed to consider the influence of the relative density of any plane of a series in determining its contribution to the reflected wave. It appears, in the first place, that two planes of atoms are equally effective if their densities are the same no matter what the wave length of the radiation may be. In the case of CaF_2 , for example, the (100) planes contain calcium and fluorine alternately, and they are approximately of equal weight, for the calcium planes contain one atom of weight 40 for every two atoms each of weight 19 contained by the fluorine planes. Now, whatever wave length we use, we find no evidence of a reflection at an angle due to a spacing equal to the distance from calcium plane to calcium plane. The first spectrum occurs

at an angle due to a spacing of half this value, the distance from calcium plane to fluorine plane: showing that these planes can be considered as equivalent. We find similar effects in other cases.

We can go a step further. Our experiments give us some opportunity of comparing the effects of planes of unequal mass when they form recurring members of a series. We have in fact assumed in previous chapters that each plane of a series contributes to the *amplitude* of the reflected ray in proportion to its mass: and we have found that the assumption is exceedingly effective and must at least have much truth in it. If so, it is of great theoretical importance.

The method of analysis of which it forms an important feature is, however, so powerful that the assumption might be no more than a rough approximation without impairing its usefulness. From a theoretical point of view it is obviously important to examine the correctness of the assumption with great care, but this has not yet been done systematically. We have, however, made one or two isolated experiments which are of some interest.

We have looked very carefully for a spectrum at a glancing angle of 4.9° in the case of the (111) planes of sylvine. We should expect to find something there if there was an effective difference between the weights of K and Cl, viz. 39.1 and 35.5; or perhaps we ought to say between their atomic numbers 19 and 17. We have found nothing, and this is in agreement with our previous assump-

tion, which would lead us to expect the intensity to be reduced from the normal in proportion to $(39.1 - 35.5)^2 / (39.1 + 35.5)^2$, or about 1 to 430. The quadratic form of this factor is a natural sequence of assuming that the planes contribute to the *amplitude* in proportion to the mass: it is this which makes the factor so small and gives a reasonable explanation of the experimental results.

If we examine the corresponding case for NaCl, in which the sodium and chlorine planes are now very different in density, we find that the explanation is nearly but not quite satisfactory. The corresponding diminution of intensity should now be $(35.5 - 23)^2 / (35.5 + 23)^2$, or 1/22. We ought to find the first, third, fifth . . . spectra to be only 1/22 as strong in comparison with the second, fourth, sixth . . . as they would be in a normal spectrum. In one set of experiments already published* the relative intensities of the first four spectra were found to be 16.5, 24.4, 3.1, and 4.2. The values for the odd order spectra were, however, very roughly measured because they were of no importance to the argument then under consideration. The present purpose requires a careful determination, and we have tried to make it, particularly in the case of the relative intensities of the third and fourth. We now find this ratio to be nearly 3 : 10.

If the spectrum had been normal the figures should have been approximately 135, 25, 9, 4: an estimate founded on arguments which will be discussed later

* *Phil. Mag.*, May, 1914, p. 889.

190 INTENSITY OF X-RAY REFLECTION

in the chapter. Introducing the effect of the want of uniformity of the planes the odd orders should be reduced in the ratio 22:1, and the figures thus become 6, 25, .4, 4, approximately. Thus the third is more intense than it ought to be according to the simple theory which makes it one-tenth of the fourth. It may be mentioned that the first spectrum is difficult to measure accurately because it is small in itself, and the allowance for 'general' radiation is so much the more difficult, and also because the rock-salt crystal which is not usually well-formed has to be set at a very fine angle to the incident ray.

It would seem that if the cardinal assumption is true, the difference between the weight of sodium and chlorine is not large enough to account for the difference in their behaviour to X-rays. Possibly there is sufficient difference in their thermal movements to account for the discrepancy. The average departures of the sodium atoms from their equilibrium positions may be greater than those of the chlorine. As will be shown below, the effect of these displacements upon the intensity of the reflection is greater the higher the order of the spectrum. This would account very well for the fact that according to the above figures the third spectrum is less reduced than the first. The thermal movements will accentuate in the third order the difference between the Na and Cl atoms which is the cause of the existence of the spectrum of the third order.

It will be obvious from the nature of this discussion that there is much experimental work to be

done in this direction and that the results may be of considerable importance. We can only say at present that, probably, the planes of a crystal mainly contribute to the amplitude of the reflection in proportion to their weight, but that it may be necessary to allow for the effect of thermal movement, or other minor sources of interference.

In this connection we may notice the remarkable fact that the ratio of the intensities of the reflection of two different wave lengths does not depend upon the nature of the crystal, except under such special circumstances as we have just considered. In other words, the form of the spectrum curve does not change obviously with the crystal used as reflector. Let us suppose that, as suggested to us by the zinblende experiment, the intensity of the reflection depends in part on the degree to which the rays penetrate the crystal. Imagine beams of two different wave lengths λ_1 and λ_2 to be constituents of the same primary radiation. The depths to which these rays penetrate the crystal, measured in terms of the mass traversed, may be satisfactorily represented by two quantities d_1 and d_2 . We may imagine two reflection coefficients ρ_1 and ρ_2 representing the amount reflected in the two cases by the same mass of crystal. Then the ratio of the reflected intensities in the two cases will be $\rho_1 d_1 / \rho_2 d_2$, because all considerations of crystal structure are the same for both; nor will the thermal movements of the atoms (see later) make much difference unless λ_1 and λ_2 are very different. The corresponding ratio for a second crys-

tal may be represented by $\rho_1'd_1'/\rho_2'd_2'$. Experiment appears to show these two ratios to be equal. But from our previous knowledge of X-ray phenomena we have $d_1/d_2 = d_1'/d_2'$. Hence $\rho_1/\rho_2 = \rho_1'/\rho_2'$. That is to say, the ratio of the reflections of any two wave lengths λ_1 and λ_2 by a certain mass of a crystal, the primary beam being kept the same, is independent of the nature and structure of the crystal. Or, to put it in another way, the ratio of the efficiencies of reflection of a given wave length by two different crystals is independent of the wave length.

The next point for consideration is the relation between the intensities of reflection of the different orders of a crystal. In previous chapters we have assumed that the intensities of the 1st, 2nd, 3rd, 4th, 5th are approximately as 100:20:7:3:1. These figures were the general average of all the results obtained where the reflection was due to a set of planes which were known to be uniform and uniformly spaced, and they were used to show the magnitude of the departure from normality due to want of uniformity. They were found to be quite good enough for their purpose. But we may now ask what explanation is to be given of this rapid decline, and again, whether it is the same even in all cases of uniform arrangement.

Perhaps it is better to answer the latter question first, and to say that even when the planes are uniform and uniformly spaced the decline in intensities is not always the same. Only a small amount of experimental work has, however, been

done in this direction. But it appears probable that the differences can be accounted for as due to varying effects of the thermal movements of the atoms of the crystal. We may consider these variations first, and afterwards the more general law which remains when the variations are allowed for.

A theoretical discussion of the effect of thermal movement upon the reflection of X-rays has been given in a series of papers by Debije.* The effect has also been discussed by Darwin.† It might be expected that temperature would diminish the intensity of reflection, and that, of course, the higher the temperature the greater would be the effect. Further, the effect of temperature would be more manifest in the higher orders, where the consequences of the departures of the atoms from their average positions are more serious, just as, in the case of a diffraction grating, the influence of irregularities is greater the higher the order of the spectrum. These anticipations are borne out by calculation. Debije finds that the influence of temperature may be represented by a factor,

$$e^{-\frac{3}{2} \cdot \frac{h^2}{\mu \lambda \theta \alpha^2} \cdot n^2 (h_1^2 + h_2^2 + h_3^2) \frac{\phi(x)}{x}},$$

in which the symbols have the following meanings :

h_1, h_2, h_3 are the direction cosines of the reflecting planes referred to the axes of the crystal.

α is the spacing of the crystal : Debije is con-

* *Verh. d. D. Phys.-Ges.*, XV., pp. 678, 738, 857 (1913); also *Ann. d. Phys.* (1914), p. 49.

† *Phil. Mag.*, Feb. 1914, p. 325.

sidering a crystal of which the atoms are in simple cubic array.

x is equal to θ/T , where T is the absolute temperature and θ the temperature characteristic of the crystal. The latter is used by Debije to denote a temperature at which the substance of the crystal stands in a certain standard relation to its specific heat. For sylvine $\theta = 219^\circ$ absolute, for fluor-spar $\theta = 474^\circ$ and for diamond $\theta = 1830^\circ$. A high value of θ implies a small thermal movement and a small capacity for heat.

$\phi(x)$ is a certain function of x which Debije evaluates.

μ is the mass of the atom.

h is Planck's constant $= 6.5 \times 10^{-27}$.

k is the gas constant $= 1.35 \times 10^{-16}$.

n is the order of the spectrum.

Since the distance (d) between consecutive planes is equal to

$$\frac{a}{\sqrt{(h_1^2 + h_2^2 + h_3^2)'}}$$

and since $n\lambda = 2d \sin \alpha$, where α is the angle of reflection, the formula may also be written

$$e^{-\frac{6h^2}{\mu k \theta} \cdot \frac{\phi(x)}{x} \cdot \frac{\sin^2 \alpha}{\lambda^2}}$$

Generally, this formula implies that the temperature effect increases with the angle of reflection and with the temperature, but decreases with the wave length and the characteristic temperature.

Experiment shows that the numerical values of

the Debije factor are at least of the right order. A crystal may be surrounded, as it stands upon the spectrometer table, by a small electric furnace, in which mica windows are constructed so as to allow of the ingress and egress of the X-rays. The temperature effects are then easy to observe: the results of a certain experiment are shown in

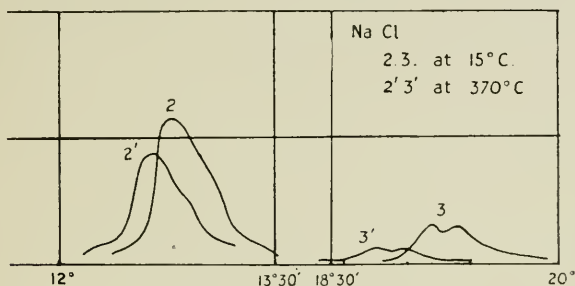

FIG. 65.

Fig. 65,* where the curves represent the second and third spectra of the rhodium line at both 15°C . and 370°C ., the crystal face being $\text{NaCl}(100)$. This line, it will be remembered, is really a close doublet. It is easily seen that the intensity of both orders is diminished by the rise in temperature, and of the third more than the second. The shift of the curves to the left is due to the expansion of the crystal with temperature, causing an increase in the spacing of the planes.

The numerical results of a series of experiments with rock salt are given in the following table, in which the first column gives the designation of the spectrum used, the second the magnitude of the sine

* *Phil. Mag.*, May, 1914.

196 INTENSITY OF X-RAY REFLECTION

of the corresponding glancing angle, the third the ratio of the original intensity to the intensity as affected by temperature, and the last the corresponding value calculated from Debye's formula. The temperatures were 15° C. and 370° C.

Spectrum.	Sine of Glancing Angle.	Ratio of Intensity at 15° C. to Intensity at 370° C.	
		Observed.	Calculated.
100 1st order	1×0.1097	1.07	1.075
110 „	$\sqrt{2} \times$ „	1.20	1.16
100 2nd order	$2 \times$ „	1.26	1.35
110 „	$2\sqrt{2} \times$ „	2.07	1.90
100 3rd order	$3 \times$ „	1.94	1.92

Though the agreement is far from perfect, there can be no doubt that the effect is a true one, and the calculations are on the right lines.

Some results for sylvine may also be quoted. Calculation from the formula shows that the ratio of the first to the second spectrum should be diminished when the temperature is raised from 17° C. to 311° C. in the ratio 1.14 to 1; and that of the ratio of first to third in the ratio 1.44 to 1. Experiment gives the rather higher values 1.18 and 1.68. On the whole, the experimental results obtained so far seem to give a rather larger change than the formula accounts for.

In the case of fluor-spar the changes are found to be quite small, and this is in agreement with the high value of the characteristic temperature. Diamond should give no measurable change, but we have not yet ventured to try the experiment.

We have seen in the preceding paragraphs that the effects of thermal movement cause appreciable variations in the intensity of the reflected spectra of different orders, and particularly those of higher orders. When these are allowed for, the allowance being different for different crystals, experiment shows that the remaining decline of intensities as we proceed from lower to higher orders seems to follow a simple rule which is the same for different crystals. It must be stated, however, that only a very few experiments which can pretend to any accuracy have been made in this direction. The rule is that the spectra fall off in intensity in the inverse square of the order: or more generally, the reflection by any set of planes of a crystal is inversely proportional to the square of the sine of the glancing angle. The latter statement is more comprehensive than the former, since it draws into one comparison the spectra from all possible reflecting planes of any one crystal. An example may be given for the case of rock salt.* The intensities of various spectra are given in the third column of the following table: the fourth column contains the intensities calculated on the basis of the simple inverse square rule, amended by the Debye temperature factor. Two sets of calculated

* *Phil. Mag.*, May, 1914, p. 893.

198 INTENSITY OF X-RAY REFLECTION

values are given; in one of which it has been supposed that $\theta=200$; in the other $\theta=280$: the latter being the more probable value according to other considerations.

Spectrum.	Sine of Glancing Angle.	Observed.	Calculated $\theta=200$.	Calculated $\theta=280$.
(100) 1st order	1×0.1097	100	100	100
(110) „	$\sqrt{2} \times$ „	41	46.3	47.6
(111) „	$\sqrt{3} \times$ „	24.4	28.5	30.2
(100) 2nd order	$2 \times$ „	18.7	19.8	21.6
(110) „	$2\sqrt{2} \times$ „	7.05	7.2	8.9
(100) 3rd order	$3 \times$ „	6.25	6.0	7.5
(111) 2nd order	$2\sqrt{3} \times$ „	4.2	3.6	4.9

The observed results are plotted as black dots in Fig. 66, and lie nearly on the lower of the two curves. The dots in circles represent the calculated values of the fifth column. The upper curve in the figure shows how the points would have been placed if the law had been that of the inverse square exactly.

The agreement is reasonable: and it is best where it might be expected to be, that is to say, in comparing the intensities of the spectra of one and the same face. The (100) spectra agree very well amongst themselves. We may take it that the inverse square law is the right basis for calculation.

No one has yet been able to give a reason for this law. It may of course be due to a combination of causes, some of which are unknown. It does not seem possible to account for it from simple diffraction principles only, for these lead us to expect a

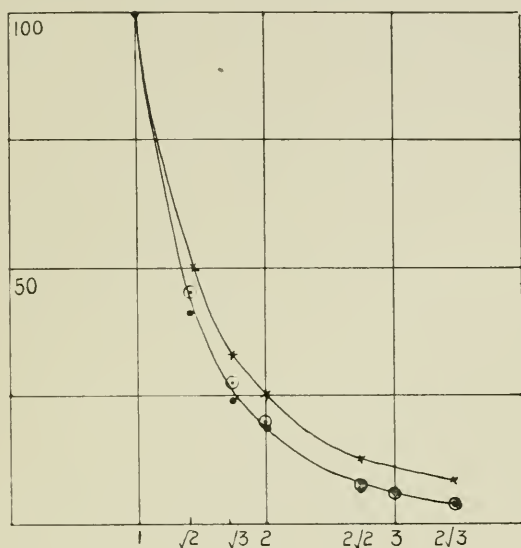

FIG. 66.

simple inverse law. The question is fully discussed by Darwin.* Possibly the scattering by a single atom depends on the angle of scattering, though this does not seem likely to account for an effect which appears to be the same for all atoms. It is strange that no explanation is forthcoming of so simple and so obvious an effect. It must certainly be answered if progress is not to be delayed. We shall leave the question here, as discussion involves so much specu-

* *Phil. Mag.*, April, 1914, p. 689.

lation. No doubt further experiment, which is much to be desired, will help to clear it up.

If we assume provisionally that there is the same law of variation of intensity with glancing angle for all cases of simple reflection, we are then left with one constant of reflection for each crystal. It becomes a matter of interest to compare these constants and to discover if possible some dependence on other known constants. Let us suppose that we have allowed for temperature effects, for the influence of 'order,' or which comes to the same thing, of glancing angle, and for any speciality in the arrangement and relative density of the planes. From what has gone before we should rather expect that penetrating power and the ability of each atom to contribute to the amplitude of the reflected beam in proportion to its mass were the only causes of difference left us; and that knowing these we ought to be able to calculate the relative reflecting power of different crystals.

Experiments of this kind are in progress. They have not gone very far, but it seems that the anticipation may possibly be realised.

Before discussing them it may be well to answer a question which might cause difficulty. How, it may be asked, is the relative intensity of reflection by different crystals to be measured? A crystal may be placed so as to intercept and to reflect partially a given primary beam. The maximum reflection that can be obtained by varying the angle of setting of the crystal will depend greatly, among

other things, upon the perfection of the crystal. Is it all one regular crystal or a collection of crystals more or less in line with each other? In order to avoid this difficulty we turn the crystal at a definite uniform rate while the X-rays are acting, or, which is sufficient, move it at each beat of a clock through a definite small angle. We commence the turning movement at an angle which gives no reflection, or a reflection due only to small disturbing causes, and turn through the reflecting angles until the reflection again becomes negligible. If the crystal is good the reflection will be strong over a narrow range, if it is bad the reflection will be moderate over a wide range. In this way we integrate the effect at all positions, and give every piece of crystal on which the primary beam falls its chance of reflection. It is in this way that the reflecting powers of different crystals are compared. In the same way were obtained the intensities of reflections of different orders and planes which are given on p. 198. A fuller discussion is given in the paper already cited.*

The following table contains the results of a few measurements of this kind, which, since they are difficult and incomplete, must be considered as liable to correction after further experiment.

CRYSTAL.	λ/ρ .	REFLECTION, IN ARBITRARY UNITS.
NaCl	5.25	142
CaF ₂	6.73	65
KCl	8.5	93
FeS ₂	15.4	90
ZnS	22.6	60

* *Phil. Mag.*, May, 1914.

202 INTENSITY OF X-RAY REFLECTION

The figures in the last column have been corrected as far as possible for thermal movement, order of spectrum, and crystal form. The absorption coefficients are not very well known as yet, and may be considerably in error. With the exception of fluor-spar the crystals show a reflecting power which increases steadily with the penetrability of the X-rays. If the intensity of reflection were simply a mass effect it would vary inversely with the absorption coefficient, which in its turn varies inversely with the amount of mass penetrated. The figures show some approximation to such a law. Fluor-spar seems to show a decided divergence: should this turn out to be real, we may possibly be obliged to seek for some other factor which influences the intensity of reflection.

There is one consideration of importance which we have neglected. While the ordinary absorption coefficient seems to be of so much importance in determining the relative intensity of reflection, it is a matter of experiment that rays which are undergoing reflection are subject to another absorption coefficient of a different kind; more properly, to a reflection coefficient. The reflection effect is so strong that the transmitted beam shows an obvious loss of the rays that are reflected; in fact, there is an absorption band. This may be seen in the following way:*

In the figure a pencil of rays AB emitted by a rhodium anticathode A is represented as passing

* *Phil Mag.*, May, 1914, p. 896.

through a slit at *B* and meeting a diamond slip at *C*, which is mounted upon the revolving table of the spectroscopie. The rays can in part pass through the diamond, and the transmitted beam meets a crystal of rock salt *C'*. The latter is adjusted until it reflects the principal rhodium ray. The ionisation chamber

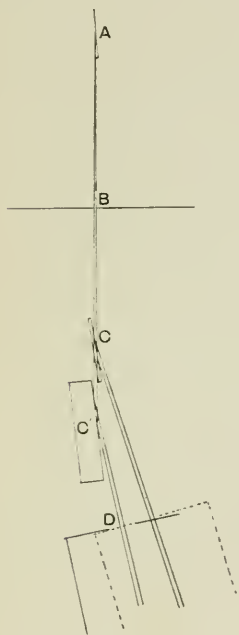

FIG. 67.

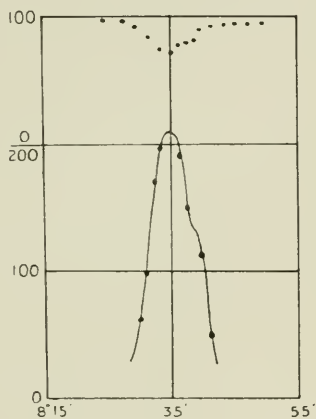

FIG. 68.

can be placed to receive either a reflection from the diamond or a reflection from the rock salt. In the former case if the diamond is gradually turned so as to pass through the angles $8^{\circ} 35'$ and $8^{\circ} 39'$, it gives an ionisation curve represented by the lower curve in Fig. 68. If now the ionisation chamber is placed so as to receive the reflection from the rock salt, and

204 INTENSITY OF X-RAY REFLECTION

the turning of the diamond is repeated, that part of the primary beam which passes through the diamond and is reflected by the rock salt shows diminutions just when the diamond is itself able to reflect. In other words, the reflection is a diversion of energy from the primary beam to the reflected beam. The readings of the rock-salt reflection are given in the upper curve of the figure; and the absorption bands are seen to correspond exactly to the peaks of the lower curve.

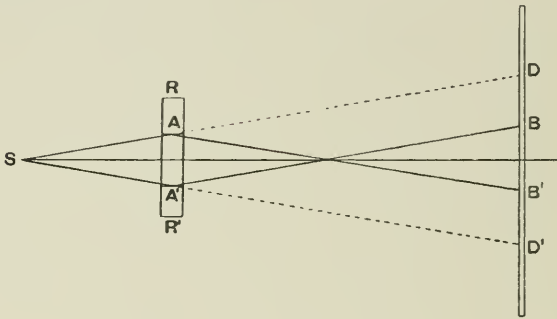

FIG. 69.

The same effect is very well shown in a recent experiment by Rutherford and Andrade. A quantity of radium emanation in an extremely fine glass tube is placed at S (Fig. 69), the tube lying along a normal to a rock-salt crystal RR . The γ rays from the radioactive products find their own reflecting planes at AA' in the crystal (the angle ASA' being about 3°) and meet a photographic plate at BB . The reflecting planes *cast shadows* at DD' . Reflection takes place also at two planes parallel to the paper, and the photographic plate shows a pattern



REFLECTION OF γ RAYS BY ROCK SALT.

(Rutherford and Andrade.)

of both light and dark lines arranged in a square pattern as in Plate IV. This experiment, it may be observed, gives an exceedingly neat and accurate method of measuring the fine angle of reflection of the γ ray.

Darwin calculates* that a pencil of rays undergoing reflection may penetrate but a very small distance into the crystal, and will be extinct long before the rays going in a slightly different direction are appreciably absorbed. Now we have seen that the ordinary absorption coefficient plays an important part in determining the amount of reflection. This seems difficult to understand if the rays undergoing reflection are absorbed at a rate which is far larger than the absorption coefficient represents them to be. It seems unlikely that the two coefficients are always proportional to each other. Darwin gives a very ingenious explanation. Assuming that crystals are imperfect, and the planes are not everywhere absolutely parallel, it may happen that some part of the beam which has not been extinguished by reflection at the surface will find a piece of the inside of the crystal at the proper angle and so will undergo reflection in the end. Such an effect will obviously involve the absorption coefficient of the rays in the crystal.

It may be said against this view that if the crystal imperfections which are here called into play are of the same kind as the crystal irregularities which the spectrometer makes so plain, then the more imperfect

* *Phil. Mag.*, April, 1914, p. 681.

the crystal as observed by the spectrometer the better it should reflect. The evidence seems to be against this conclusion. Rock salt is certainly a bad crystal and gives an excellent reflection, but no more than might be expected from the smallness both of the glancing angle and of the absorption coefficient. Different specimens of rock salt vary greatly in perfection; but the worse pieces do not reflect better than the others; indeed, it is rather the reverse. Zinblende and iron pyrites give sharp reflections and may be called good crystals; but after allowing for magnitude of glancing angle and so forth, their reflections seem quite as strong as those of rock salt.

It is interesting to observe also that theory does not seem able to give an adequate explanation of the intensity of the reflection.*

We have now considered in turn (1) the relative reflecting capacities of the different members of a set of reflecting planes; (2) the relations between the intensities of different orders; (3) the relations between the intensities of reflection of different crystals; and (4) the absolute magnitude and the details of reflection by any one crystal. The sketch is obviously most incomplete: but it may show at once the directions in which progress is being attempted and the amount of work there is to do.

* *Phil. Mag.*, April, 1914, p. 684.

CHAPTER XII.

THE ANALYSIS OF THE LAUE PHOTOGRAPHS.

THE Laue photographs are due to the diffraction by the crystal of the 'white' or general radiation proceeding from an X-ray bulb. All anticathodes give a certain amount of this white radiation, in addition to the monochromatic rays which form the line spectrum of the metal of which they are made. A platinum or iridium anticathode, such as is generally used when a Laue photograph is taken, gives off most of its X-ray energy in the form of the general radiation.

Fig. 20 shows the strength of the reflection in the plane (100) of rock salt over a large range of glancing angles, the anticathode being composed of platinum. It must be remembered that at any definite angle, the reflected beam received by the ionisation chamber is in one sense not monochromatic. It consists of all wave lengths given by the equation

$$n\lambda = 2d \sin \theta,$$

that is to say, it is composed of a series of wave lengths, λ , $\frac{\lambda}{2}$, $\frac{\lambda}{3}$, $\frac{\lambda}{4}$, etc. The greater part of it, how-

ever, consists of the wave length λ , which gives a first order reflection at this angle. The strength of the reflection at all angles is represented by a smooth curve (the peaks due to the line spectrum not being taken into account), and although this curve does not give us directly the energy at all points in the spectrum of the rays, it shows that this energy is distributed over the spectrum in a continuous manner.

Each spot in a Laue photograph represents the reflection of the X-rays by a certain plane (hkl) of the crystal structure. It is possible to calculate from the positions of the spots the indices (hkl) of the planes, in which reflection has occurred, and of course also the angle of incidence of the rays on these planes. The efficiency with which each reflection has taken place is also recorded and roughly indicated by the intensity of the corresponding spot on the plate. The information thus given is very different indeed from that given by the X-ray spectrometer, which examines each plane in detail by itself, the monochromatic radiation which it employs remaining approximately constant in intensity during the examination of each face. In the Laue photograph every spot represents the action of waves of a different wave length, for d and θ vary from spot to spot. When we compare the intensities of two spots, we are comparing the reflection of two different regions of the spectrum, and initially we do not know the relation between the amounts of radiation of either kind present in the incident X-ray beam.

The exact position of the spot is fixed by geometry, and yields no useful information.

In spite of the limitations of this method of investigation, it is possible to deduce the structure of the very simplest crystals from a study of the photographs.

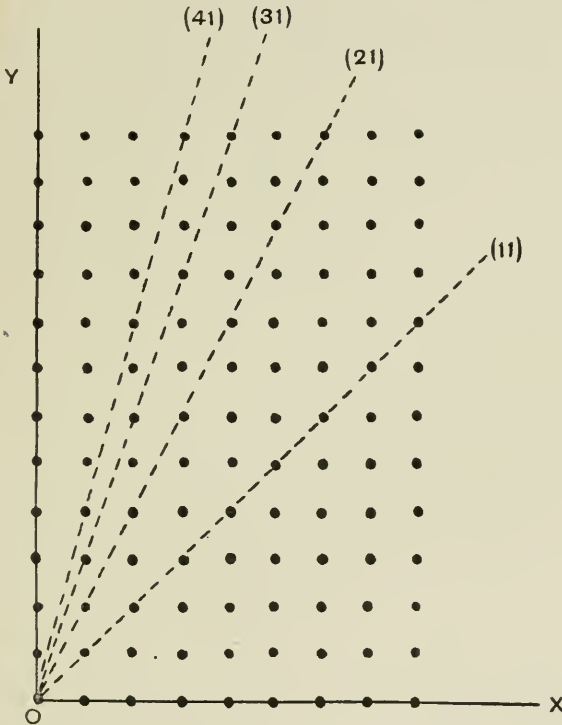

FIG. 70.

An example in two dimensions will best explain how this is possible. In Fig. 70 the points represent a crystalline structure, which is referred for convenience to the axes OX , OY .

210 ANALYSIS OF LAUE PHOTOGRAPHS

In Fig. 71 a section of a crystal with this structure is supposed to be placed at O , the incident rays are represented by the pencil AO , and the reflected rays by the pencils OS_1 , OS_2 , OS_3 . The rows of the crystal structure, which reflect the rays along these paths, have indices (hk) , which correspond to

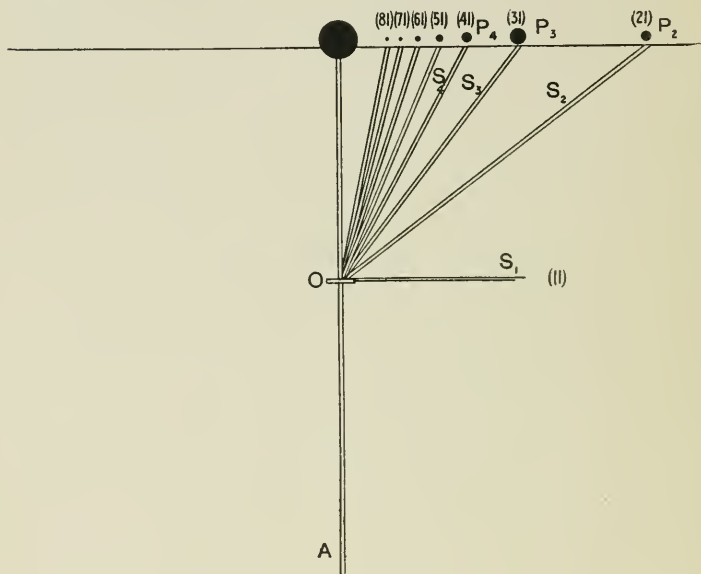

FIG. 71.

the indices (hkl) of a three-dimensional crystal. The set of rows which are represented as dotted lines in Fig. 70, for instance, have indices (11) , (21) , (31) , (41) , respectively. Each of these types of rows in the crystal reflects a portion of the incident X-ray beam, the reflected rays travelling along OS_1 , OS_2 , OS_3 , etc., and making spots S_2 , S_3 , etc., on the photographic plate. In the diagram, the reflected ray

OS_1 does not fall on the photographic plate, and so makes no impression, but the other rays do, and as a result the plate when developed shows a series of spots P_2, P_3, P_4 , etc. This is a two-dimensional Laue photograph.

Consider now the properties of the rows with indices $(11), (21), (31)$, etc. The angle of incidence of the rays on the row, the distance between successive rows, the number of points per unit length of the row, and such other properties differ for each member of the series. They vary, however, in a perfectly regular manner as one reviews the series of rows. For instance, the wave length of the reflected beam and the density of the points on the reflecting rows decrease in an orderly manner as one takes the planes in succession. The wave length is determined, of course, by the spacing of the planes under consideration and by the angle of incidence. If this wave length belongs to a part of the spectrum in which the energy is large, the reflection will be strong; if not, it will be weak. The strength of the reflection also depends on other considerations, such as the density of points along a row mentioned above, and so forth. From Fig. 20 we know that the amount of energy in the spectrum varies continuously from wave length to wave length, and we also see that the properties of the rows vary regularly through the series, so that, taking everything into consideration, it is to be expected that the strength of the reflected beam will vary regularly through the series. If in Fig. 71 the spots P_2, P_3, P_4 represent by their size the

intensity of the corresponding spot in the photograph, they will form a regular series such as is there shown. That is to say, every spot will be more or less intermediate in intensity between its neighbours, and there will be no sudden discontinuities in the series.

Fig. 72 represents a different crystalline structure. The points are now of two kinds. As before, the

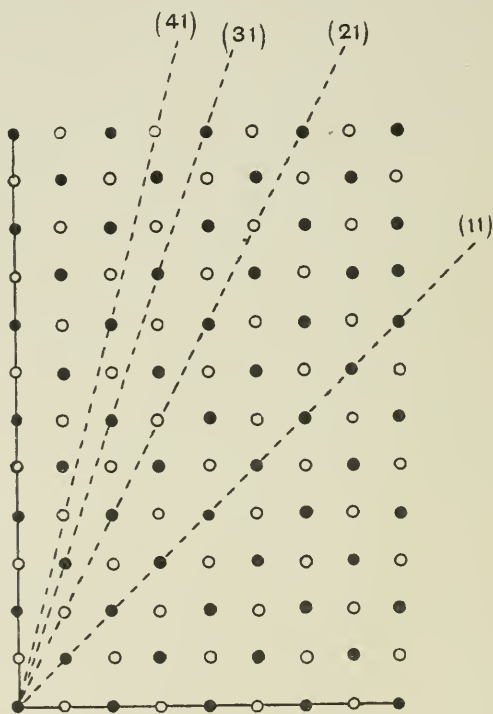

FIG. 72.

rows with indices (11), (21), (31), (41) have been dotted in. It is perhaps clear from this figure that these rows are not all of the same nature. The

rows with indices (11) , (31) , (51) are rows of points all of a kind. Each single row has only white or black points on it, the alternate rows being black and white. The rows (11) show this well. On the other hand, the rows (21) (41) (61) contain points of both kinds in equal numbers, and all the rows of the series, (21) for example, are identical in nature. We must divide our series into two parts, one of which contains the planes (11) , (31) , (51) , and the other the planes (21) , (41) , (61) . The properties of the planes vary regularly for members of each of these divisions, but they do not vary continuously as one reviews the complete series.

This division of the planes into two sets will inevitably betray itself in the intensities of the spots; it will no longer be true that all the spots form a regular series, but every odd spot will belong to one series, every even spot to another. Therefore, conversely, if we notice this peculiarity in the spots, we are led to imagine the structure of Fig. 72 as the cause of it.

This is the kind of information which the Laue photographs give concerning the crystal structure. We consider the spots in the photograph which correspond to reflection in a series of planes of the crystal such as the series

$$\begin{array}{cccc}
 (111) & (211) & (311) & (411) \\
 (121) & (221) & (321) & \\
 (131) & (231) & (331) & \\
 (141) & & &
 \end{array}$$

In some cases these spots show perfect regularity

as regards their intensity. In other cases the spots with wholly odd indices, such as (311) , (531) , are a set apart from the others, exhibiting regularity among themselves, while the rest also exhibit regularity when 'odd' spots are not regarded. Yet

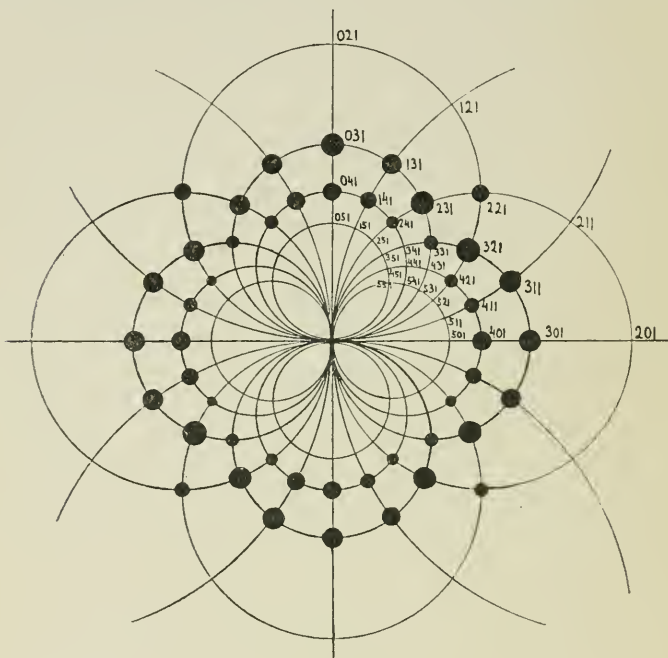

FIG. 73.

again, there are crystals for which the spots are divided into three sets: firstly, those with wholly odd indices; secondly, the spots with one even index and two odd indices (141); thirdly, the set with two even indices and one odd index (041), (241). In each case the corresponding crystal structure can be deduced.

When the whole series of spots shows regularity it corresponds to a crystal structure which has atoms at every point of a simple cubic lattice, just as the regularity in the two-dimensional example corresponded to an arrangement of identical points in squares. Fig. 73 shows diagrammatically the photograph yielded by potassium chloride, the spots on the actual photograph being represented in the diagram as dots of corresponding magnitude. The indices of the planes, in which the spots are reflected, are marked on the diagram. We have already seen that potassium chloride is for our purpose a perfect simple cubic lattice, and we now see the absolute regularity of the Laue pattern which it yields. Every simple index within a certain range is represented, and all spots are intermediate in intensity between their neighbours.

Compare this with the diagram Fig. 74 representing the Laue photograph of rock salt.

It is evident that the perfect regularity has disappeared. Instead of there being a spot at every intersection of the circles, there are gaps. For instance, there are spots corresponding to reflection in the planes (511) , (531) , but none corresponding to reflection in the planes (501) , (521) , (541) . There are (331) , (351) , but no (341) , and so on. There is, in fact, a preference for the odd as against the even indices; the series of planes (hkl) is divided into two sets, one of which contains all planes with wholly odd indices and the other the rest of the planes.

The two-dimensional examples gives the key to the explanation of this division. The photograph applies to a crystal structure such as that shown in Fig. 72, p. 212. We are dealing with points of two kinds, arranged alternately in a three-dimensional

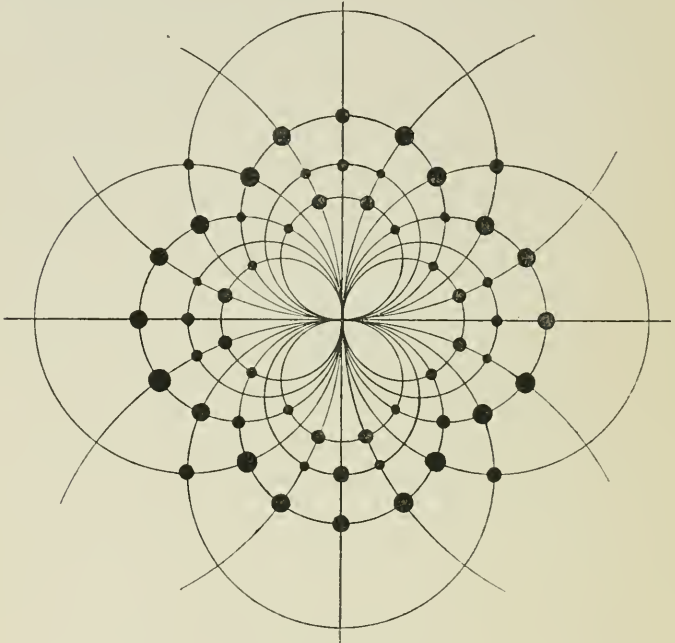

FIG. 74.

structure analogous to that of Fig. 28. Potassium bromide and iodide repeat the peculiarities of rock salt in a more marked manner, as would be expected, for in these crystals the difference between the two kinds of diffracting points is accentuated.

The division between 'odd' and 'even' planes as reflectors is the characteristic of the face-centred

cubic lattice. This is only another way of stating the conclusion already arrived at. The face-centred lattice may be looked on as an extreme case of the rock salt structure, in which one atom has become negligible in comparison with the other. The broad features of the Laue photograph are a guide to the underlying space lattice of the crystal structure exactly as are the positions of the first spectra obtained by the spectrometer.

The crystal which Laue employed for exact investigation of his new discovery was zincblende. This crystal, as we have seen, is composed of two interpenetrating face-centred cubic lattices, their relation to each other being explained on p. 100. The feature of the structure which will impress itself most strongly on the Laue photograph is the arrangement of heavy zinc atoms on a face-centred cubic lattice. Hence, examining the series of plane (hkl), we find them divided into two sets :

(1) Odd planes (131), (151), (531), etc.

(2) Even planes (231), (241), (051), etc.

This division is very marked indeed. Owing, however, to the peculiar relation of the sulphur to the zinc lattice, the even planes are again subdivided into two sets :

(2*a*) Planes with one even integer (231), (051) ;

(2*b*) Planes with two even integers (241), (041) ;

this being due to the fact that the planes (2*a*) contain both zinc and sulphur atoms, the planes (2*b*) contain zinc alone and sulphur alone. This

division is also traceable in the Laue photograph of zincblende.

The combined effect of this division and subdivision of the planes is to make the pattern of spots appear very complicated indeed. So much was this the case that in the early interpretations the peculiarities of the spectrum, not those of the crystal, were imagined to be the cause of the complications in the pattern. As we have shown, each spot of the pattern must be caused by rays of a series of definite wave lengths, given by

$$\lambda = \frac{2d \sin \theta}{n}.$$

The incident radiation was supposed to contain five narrow bands or broad lines in its spectrum, and the spots were explained as reflections of these bands by planes which just happened to be oriented in the right way to reflect them. The other planes did not reflect because it happened that their spacing was not of the right magnitude to bring about reflection of any of the bands. The values of d and $\sin \theta$ could be calculated for each spot, which was in fact due to homogeneous waves of any of the wave lengths

$$\frac{2d \sin \theta}{n}.$$

When any one of these wave lengths fell within a band on the spectrum the spot would be strong. If it did not the spot would be faint or invisible. In this way all peculiarities of the pattern were explained, and explanation was always possible if the

existence of a sufficiently large number of bands was assumed.

A simple experiment shows, however, that the effect is due to a continuous spectrum, and not to a series of bands. A series of photographs can be taken with the crystal in slightly different positions, so that the angle of incidence of the rays on each set of planes varies. If the spot reflected in these planes appears merely because one of the values,

$$\frac{2d \sin \theta}{n},$$

happens to be exactly right, and to coincide with the wave length of one of the bands, this spot should disappear when θ is altered. As a matter of fact, the same spot can be traced in a succession of photographs, and though generally its intensity alters, this happens in a perfectly regular manner. It was this phenomenon which led to the supposition that the Laue photographs really represented the diffraction of a continuous spectrum,* although the X-ray spectrometer had not yet given its decisive evidence on this point.

Although the radiation emitted by a bulb with a platinum anticathode consists mainly of this general radiation, there are yet the five lines in its spectrum already described (p. 75). The question now arises as to whether these homogeneous components will in any way influence the Laue photographs. At first sight it might appear that this was possible, for there are five lines in the spectrum, and several orders of

* W. L. Bragg, *Proc. Camb. Phil. Soc.*, XVII. Part I. p. 43.

220 ANALYSIS OF LAUE PHOTOGRAPHS

reflection, and it does not seem impossible that one or more of the many crystal planes should be oriented in such a way as to reflect one of the lines. We will therefore compare the wave lengths which form the spots with those of the lines in a Pt spectrum.

The following are the wave lengths, corresponding to reflection of the first order, which form the spots of the KCl Laue-photograph. The reflecting planes all have indices of the form $(h\bar{k}l)$. The figures represent $\lambda \times 10^8$.

		<i>h</i>				
		0	1	2	3	4
<i>k</i>	0				.62	.37
	1				.57	.35
	2			.69	.45	.30
	3	.62	.57	.45	.33	
	4	.37	.35	.30		

The extreme range of wave length represented lies between

$$\lambda = 0.69 \times 10^{-8} \text{ cm. and } \lambda = 0.30 \times 10^{-8}.$$

The five platinum lines are composed of a single line and two doublets, the approximate wave lengths being

$$\lambda_1 \text{ and } \lambda_2 = 0.96 \times 10^{-8} \text{ cm.,}$$

$$\lambda_3 \text{ and } \lambda_4 = 1.12 \times 10^{-8},$$

$$\lambda_5 = 1.31 \times 10^{-8}.$$

All these lie quite outside the range of wave lengths to which the spots on the Laue photograph are due. However, it might be supposed that since

in the NaCl structure, where the spacing of such odd planes as the plane (131) is doubled, it is conceivable that some of such lines may be reflected as a first spectrum. For such planes, however, the first spectrum is very weak compared with the second (see p. 96).

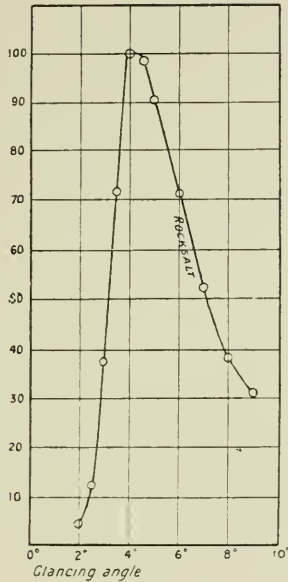

FIG. 75.

Moreover, in order to reflect a monochromatic radiation, the setting of the crystal must be very exact. Taking all this into account, it is very unlikely that the Laue photograph should be complicated by the reflection of the platinum line spectrum.

Fig. 75 shows the measurements of Moseley and Darwin* on the general radiation from a Pt

* *Phil. Mag.*, July, 1913.

anticathode. The amount of radiation reflected from the face (100) of rock salt is plotted against the angle of reflection. Now it is a useful, ready rule that the wave length reflected at any small angle from NaCl (100) is approximately equal to the glancing angle multiplied by 10^{-9} . We see that the main part of the general radiation lies in the region between the wave lengths 0.3×10^{-8} cm. and 0.8×10^{-8} cm. We have already seen that the spots in the KCl pattern correspond to the region 0.3×10^{-8} to 0.7×10^{-8} cm. Thus these widely different experiments confirm each other remarkably well.

Further, the most marked spot on the photograph is that reflected in the plane (321). This corresponds to the wave length $.45 \times 10^{-8}$ cm., and, as is seen from the curve in Fig. 75, this wave length is in the very strongest part of the spectrum.

In a case like this nothing can be simpler than the explanation of the Laue photograph. Given the arrangement of the K and Cl atoms on a cubic lattice, and the results of Moseley and Darwin's work on the white radiation from a platinum anticathode, we could predict with absolute certainty the distribution and intensity of the spots. It would still be possible to attempt this in the case of NaCl, though we would then have to take account of both first and second orders for such planes as (111), in order to determine the intensity of the resulting spot. Zincblende and fluor-spar present a still higher order of complication. It is possible from the photographs to fix the atoms of the metal on a face-centred

lattice, but it needs a careful analysis to place the sulphur and fluorine atoms in each case. When the disposition of these atoms was discovered by the X-ray spectrometer, the photograph was at once explained; until then its peculiarities could only hint at the probable structure of the crystal. Yet these crystal structures are of a very simple nature. To discover such structures as those of pyrites, or of calcite, by means of the Laue photographs, would seem almost impossible.

Recently, however, some interesting results have been published by P. P. Ewald,* who uses the Laue photographs in order to obtain an exact knowledge of the structure of such crystals as pyrites. The structure which the X-ray spectrometer assigns to the crystal has already been given (p. 133). It will be remembered that the sulphur atoms are displaced along the cube diagonals until they divide these in approximately the ratio 1 : 4. Ewald takes this approximate determination of the crystal structure, and then employs the Laue photograph of pyrites in order to find the precise ratio in which the diagonal is divided.

The way in which this is done is as follows: Consider the reflection of two such planes as $1\bar{8}\bar{2}$ and $81\bar{2}$. If the crystal had holohedral symmetry, these planes would yield reflections identical in strength; but because of the peculiar symmetry of pyrites, it is found, as a matter of fact, that the two corresponding spots in the Laue photograph are very different in

* P. P. Ewald, *Phys. Zeit.*, 1914, pp. 399-401.

intensity. This difference in intensity is to be ascribed to the action of the sulphur atoms alone, as the iron atoms have a perfectly holohedral arrangement.

When the rays are reflected from the planes $81\bar{2}$, the displaced sulphur atoms each contribute their quota to the reflected wave train, these quota having the same amplitude, but differing in phase. Ewald considers that the sum of the contributions of the sulphur atoms may be represented by

$$\begin{aligned}\Sigma = & (-1)^{h_3} \cos \frac{\pi\alpha}{5} (h_1 - h_2 - h_3) \\ & + (-1)^{h_1} \cos \frac{\pi\alpha}{5} (-h_1 + h_2 - h_3) \\ & + (-1)^{h_2} \cos \frac{\pi\alpha}{5} (-h_1 - h_2 + h_3) \\ & + (-1)^{h_1+h_2+h_3} \cos \frac{\pi\alpha}{5} (h_1 + h_2 + h_3),\end{aligned}$$

where $\frac{\alpha}{5}$, instead of $\frac{1}{5}$, determines the position of the sulphur atom. Now, if the sulphur atoms were exactly $\frac{1}{5}$ th the distance along the cube diagonal, the expression Σ comes to the same value if we substitute for h_1, h_2, h_3 the numbers $81\bar{2}$ or $18\bar{2}$. Therefore, Ewald considers that these spots should have the same strength if the ratio $\frac{1}{5}$ were true, whereas, experimentally, he finds them very different in intensity. The same is true for the spots $(37\bar{2})$ and $(73\bar{2})$.

From this and other similar data Ewald draws the conclusion that the sulphur atom does not divide the

diagonal in the ratio 1 : 4, but in the ratio .224 : .776 correct to $\pm .002$.

There is no doubt that this method ought to place to a high degree of accuracy the sulphur atoms. On the other hand, in the examination in question Ewald does not appear to have considered the higher orders of reflection, which may quite overpower a weak first order. He also neglects the effect of the iron atoms in contributing their amplitude, and the fact that the fundamental wave length is not in all cases the same for planes $8\bar{1}\bar{2}$ and $1\bar{8}\bar{2}$, but may be twice as great for the one as for the other (see p. 151). It seems impossible to avoid assuming some empirical laws governing the intensities of different orders of reflection, even by this method.

SUPPLEMENTARY NOTES.

1. The crystals ZnO, ZnS (hexagonal form) and CdS are supposed to possess identical structures: they are dihexagonal polar.

The structure of zinc oxide has been completely determined. The zinc atoms considered separately from the oxygen atoms are in hexagonal close packing: so also are the oxygen atoms, considered separately from the zinc. The two lattices are of exactly the same form, and can be brought to coincidence by relative movement along the hexagonal axis. Cadmium sulphide has not been examined in detail, but the base of the hexagon gives spectra in accordance with the above hypothesis.

Presuming that the hexagonal form of ZnS is of the same structure, it is interesting and instructive to compare it with the cubic form. In the former crystal there are alternate layers of zinc and sulphur atoms, just as in the latter: the one essential difference is that in the former the zinc atoms are in close-packed hexagonal; in the latter, are close packed in the cubic arrangement.

It is possible that graphite is related to diamond, somewhat as the two forms of zinc sulphide are related to each other. There is some suggestion that the separate networks of atoms, each consisting of two layers of carbon atoms separated by 0.51×10^{-8} , exist in the same form in graphite as in diamond; but in the former the spacing of network to network is increased from 2.05×10^{-8} cm. to about 3.42×10^{-8} cm. At any rate the densities of the two crystals are nearly in that proportion, being 2.5 and 3.7 respectively.

Bismuth and antimony have been found to be exactly like the diamond in construction, except that the whole structure is distorted along a trigonal axis.

The structure of aragonite and its relation to calcite have been studied, but a perfectly satisfactory solution has not been reached.

2. The rhodium spectrum contains a faint line having a wave-length 0.534×10^{-8} , somewhat shorter than those previously described, viz. 0.545, 0.614 and 0.619 A.U. The corresponding wave lengths in the silver spectrum are 0.488, 0.495, 0.557, and 0.562 A.U. In the palladium spectrum they are 0.503, 0.516, 0.583 and 0.589 A.U. Apparently the silver wave-length 0.557 A.U. cannot excite any of the palladium rays, since its absorption by Pd is on the same small scale (see p. 179) as that of longer waves which are known to be unable to do so. Yet this wave-length is appreciably shorter than the 0.583 of Pd. On the other hand, the shorter silver wave-length 0.495 A.U. is only just shorter than the 0.503 A.U. of Pd, and can apparently excite all the Pd waves. It seems worth while enquiring whether it is possible to excite the longer wave-lengths of an X-ray spectrum without exciting the others; and whether the exciting wave must be just shorter than the shortest wave in the spectrum which it is to excite.

3. Several workers have employed rock salt in the analysis of X-ray spectra. Rock salt is, however, a very imperfect crystal, and may give false effects. Calcite is a very perfect reflector, nearly, if not quite, as good as diamond, but the reflection is much less intense. Even iron pyrites and zinc-blende reflect more truly than rock salt.

INDEX.

- Absorption of X-rays, 40, 175
et sqq., 203.
Ammonium chloride, 110.
Andrade, 85, 204.
Atomic numbers, 78.
- Barkla, 2, 39, 68.
Beryl, 8.
Bohr, 82.
van den Broek, 78.
de Broglie, 84.
- Cadmium sulphide, 173.
Calcite class, 112.
Cobaltite, 154.
Copper, 173.
Crystal imperfections, 34.
Cubic crystals, 56.
Cuprite, 155.
- Darwin, 75, 193, 199, 205, 221.
Debye, 140, 193, 197.
Diamond, 102 *et sqq.*
- Ewald, 223.
- Fajans, 85.
Fluor-spar, 107.
- Galena, 173.
- Haematite, 169.
Hauerite, 154.
Hemihedrism, 148.
- Iron pyrites, 127.
- Laue, 5, 207 *et sqq.*
- Marx, 1.
Moseley, 75 *et sqq.*, 77, 221.
- Nickel sulphate, 8.
- Planck's constant, 71.
Platinum spectrum, 67.
Polarity of ZnS, 145.
- Quartz, 160 *et sqq.*
- Reflection by set of planes, 16.
Resolving power, 37.
Rhodium doublet, 30, 86.
Rock salt, 89.
Ruby, 169.
Rutherford, 75, 85, 204.
- Soddy, 85.
Space lattices, 51.
Spectrometer, 22, 23 *et sqq.*
Sulphur, 167.
Sylvine, 89.
- Temperature effects, 195.
- Whiddington, 72.
Wilson, 46.
- Zinc-blende, 97.
Zincite, 173.

Third Edition. Demy 8vo. Illustrated. 6s. net.

ELECTRONS

OR

THE NATURE AND PROPERTIES OF NEGATIVE ELECTRICITY

BY

SIR OLIVER LODGE, F.R.S., D.Sc., LL.D.

PRINCIPAL OF THE UNIVERSITY OF BIRMINGHAM

“At the present time there are few more absorbing topics among physicists and chemists than the electron and its relation to matter, and none on which a more complete mystification exists : and the present book, from the pen of a writer to whom so often in the past the student has looked for light and leading in difficult places, will therefore be opened with curiosity and read with eagerness.”—*Nature*.

“We consider Sir Oliver Lodge’s book an admirable exposition of a subject in great need of general explanation, our nearness to which makes clear exposition very difficult. We think, too, that he has shown laudable discretion as to those points which are already susceptible of decision and those which are not.”—*Athenæum*.

“Sir Oliver Lodge has done a good service for the layman in writing this admirable book, which is a brief, accurate, and reasonably simple account of the electron theory, and the leading experiments on which it is based, divested as far as possible of mathematical language. . . . His book will be read with the greatest interest by all who desire to stand abreast of the latest investigations into the ultimate problems of the physical universe.”—*Manchester Guardian*.

“The subject matter is of the highest interest, and is brought before the reader in a very convincing manner. . . . His exposition is so direct that the veriest tyro of a student can hardly fail to see the force of his reasoning or to accept his conclusions.”—*Electrical Engineer*.

“Physicists, students of electricity especially, will owe to Sir Oliver Lodge a deep obligation for this luminous work. It demands study and amply repays it.”—*Daily Telegraph*.

LONDON: G. BELL AND SONS, LTD.

Royal 8vo. 6s. net.

MODERN INSTRUMENTS AND METHODS OF CALCULATION

BEING A DESCRIPTION
OF BOOKS, INSTRUMENTS AND DEVICES FOR
FACILITATING CALCULATION

EDITED BY

E. M. HORSBURGH, M.A., B.Sc., Assoc.M.Inst.C.E.

LECTURER IN TECHNICAL MATHEMATICS IN THE UNIVERSITY OF EDINBURGH

WITH THE CO-OPERATION OF THE FOLLOWING COMMITTEE

HERBERT BELL, M.A., B.Sc.
G. A. CARSE, M.A., D.Sc.
DAVID GIBB, M.A., B.Sc.

CARGILL G. KNOTT, D.Sc., *Hon. Secretary.*
J. R. MILNE, D.Sc.
E. T. WHITTAKER, Sc.D., F.R.S., *Convener.*

This manual has been described by one of the most eminent experts in Computation as "the only authoritative treatise in existence on the art of calculation," and should be useful to the laboratory computer, the engineer, the astronomer, the statistician, and all who are interested in the art of calculation.

"All who are interested in the history or the methods of calculation owe a debt of gratitude to the editor and the committee who have produced this valuable book. . . . Seeing that the price asked for a large 8vo book of 343 pages, containing a very large number of excellent illustrations, is only six shillings, those who are interested should feel that the work is in effect a gift."—*Nature*.

"This handsome volume forms a permanent and valuable record of the exhibition organised in connection with the Napier celebration. The price, moreover, is exceedingly moderate. The first sections are devoted to Napier, and include a very readable account of his life and works by Professor G. A. Gibson. Section C contains a descriptive list of mathematical tables. . . . The following sections, dealing with calculating machines and instruments, are probably the most valuable feature of the book, for they bring together a mass of information, much of which is new and certainly has hitherto not been easily accessible. . . . The final sections deal with ruled papers and mathematical models."—*School World*.

LONDON: G. BELL AND SONS, LTD.

FOR

THE ROYAL SOCIETY OF EDINBURGH



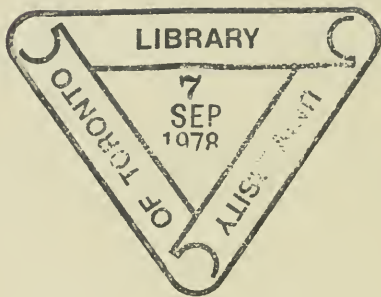

PLEASE DO NOT REMOVE
CARDS OR SLIPS FROM THIS POCKET

UNIVERSITY OF TORONTO LIBRARY

QD
945
B7

Bragg, (Sir) William Henry
X rays and crystal structure

P&ASci.

