



















P.V. 24

16

500  
64840  
Smith  
17

# SCIENCE

---

A WEEKLY JOURNAL

DEVOTED TO THE ADVANCEMENT OF SCIENCE.

---

EDITORIAL COMMITTEE: S. NEWCOMB, Mathematics; R. S. WOODWARD, Mechanics; E. C. PICKERING, Astronomy; T. C. MENDENHALL, Physics; R. H. THURSTON, Engineering; IRA REMSEN, Chemistry; J. LE CONTE, Geology; W. M. DAVIS, Physiography; O. C. MARSH, Paleontology; W. K. BROOKS, C. HART MERRIAM, Zoology; S. H. SCUDDER, Entomology; C. E. BESSEY, N. L. BRITTON, Botany; HENRY F. OSBORN, General Biology; C. S. MINOR, Embryology, Histology; H. P. BOWDITCH, Physiology; J. S. BILLINGS, Hygiene; J. MCKEEN CATTELL, Psychology; DANIEL G. BRINTON, J. W. POWELL, Anthropology.

NEW SERIES. VOLUME VIII.

JULY - DECEMBER, 1898.

---

NEW YORK  
THE MACMILLAN COMPANY  
1898

---

THE NEW ERA PRINTING COMPANY,  
41 NORTH QUEEN STREET,  
LANCASTER, PA.

---



# CONTENTS AND INDEX.

N. S. VOL. VIII.—JULY TO DECEMBER, 1898.

*The Names of Contributors are Printed in Small Capitals.*

- Affiliated Societies, with the A. A. A. S., 72  
Agricultural, Production, Variations, J. HYDE, 575 ;  
Colleges, Association, A. C. TRUE, 761  
Agriculture, Secretary of, Report, A. C. TRUE, 847  
Air, A New Constituent of, W. RAMSAY, 1  
Alabama Industrial and Scientific Society, E. A. SMITH, 720  
American Association, Meeting, 17, 57, 141, 226 ;  
President's Address, WOLCOTT GIBBS, 233 ; Fiftieth Anniversary, 269 ; Greeting to the Boston Meeting, J. M. CRAFTS, 274 ; Report of Committees, H. CARRINGTON BOLTON, 323 ; H. S. CARRHART, 326 ; Zoology, R. T. JACKSON, 395 ; Geology and Geography, WARREN UPHAM, 462, 501 ; Chemistry, C. BASKERVILLE, 521 ; Physics, N. E. DORSEY, 529 ; Botany, E. F. SMITH, 651, 690  
Ames, J. S., Free Expansion of Gases, M., 675  
Anderson, R. E., Extinct Civilizations of the East, D. G. BRINTON, 265  
'Anlage,' its Equivalent, BURT G. WILDER, 793 ; or Proton? CHARLES SEDGWICK MINOR, 906  
Antarctic Exploration, British Government and, 100  
Anthony, W. A., Electrical Measurements, F. E. N., 838  
Anthropological Exhibit, Omaha, W. H. HOLMES, 37  
Anthropology, Current Notes, D. G. BRINTON, 16, 42, 71, 99, 126, 155, 180, 217, 260, 296, 328, 365, 407, 440, 474, 508, 545, 588, 626, 741, 787, 831, 862, 901, 948  
Appell, P., Mécanique rationnelle, R. S. W., 190  
Archibald, D., The Atmosphere, F. WALDO, 304  
ARTHUR, J. C., Plant Physiology, W. Detmer, 597  
Astronomical Notes, WINSLOW UPON, 623  
Astrophysical Conference, Harvard, M. B. SNYDER, 449  
Atavism, The Delusion of, F. A. L., 267  
Atkinson, Geo. F., Botany, C. MACMILLAN, 796  
Aurora, An Unusual, SIMON NEWCOMB, 410  
AYRTON, W. E., and JONES, J. V., An Ampere Balance, 858  
B., H. C., Metallic Carbides, J. A. MATHEWS, 110  
Bacteriological Notes, SIMON FLEKNER, 406  
BAILEY, VERNON, New Name for *Microtus insularis* Bailey, 782  
Balance, An Ampere, W. E. AYRTON and J. V. JONES  
BALDWIN, J. MARK, Language Study, 94  
BANGS, OUTRAM, New Name for the Georgia Old Field Mouse, 214 [386  
BARNARD, E. E., Photography in Astronomy, 341,  
BARNES, C. R., Plant-Life, CHARLES E. BESSEY, 372  
BARIS, CARL, Inertia as a Manifestation of the Ether, 681  
BASKERVILLE, C., Chemistry at the American Association, 521  
BATHER, F. A., Zoological Bibliography and Publication, 872  
Batrachians, Tailless, THEO. GILL, 932  
Baur, George, O. P. HAY, 68  
BEAUCHAMP, W. M., Wampum Belts, 596  
Bertrand, A., Au Pays des ha-Rotsi, W. LIBBEY, 163  
BESSEY, CHARLES E., Science Teachers' Conference, 123 ; Illustrated Flora of the United States, Canada, etc., N. L. BRITTON and A. BROWN, 195 ; Botanical Notes, 215, 257, 587, 702, 785 ; Plant-Life, C. R. BARNES, 372  
Bibliographical Data for Books, 44  
Bibliography and Publication, Zoological, F. A. BATHER, 872 ; WM. H. DALL, 709, 955  
Binet, A. et Henri, V., La fatigue intellectuelle, J. JASTROW, 132  
Biological, Survey of Lake Erie, H. M. SMITH, 13 ; Laboratory of the United States Fish Commission, Woods Holl, H. C. BUMPUS, 96 ; Station of the Indiana University, 298 ; Society of Washington, F. A. LUCAS, 678, 717, 799, 918  
Bipolarity, of Polar Faunas, A. E. ORTMANN, 516 ; Hypothesis, W. A. HERDMAN, 707  
Blackall, R. H., Air-brake Catechism, R. H. T., 637  
BLISS, C. B., N. Y. Acad. of Sciences, Psychology and Anthropology, 919  
BOLTON, H. CARRINGTON, An American Blue Grotto, 266 ; Committee on Indexing Chemical Literature, Report, 323  
Boston Society of Natural History, S. HENSHAW, 799, 960  
Botanical Club, Torrey, E. S. BURGESS, 56, 83, 112, 719 ; Engelmann, J. B. S. NORTON, 84, 196 ; H. VON SCHRENK, 639 ; Notes, CHARLES E. BESSEY, 215, 257, 587, 702, 785 ; Society of America, 471 ; Seminar of the Univ. of Nebraska, 720  
BOUTWELL, J. M., Harvard Geological Conference, 560, 680 ; Harvard Geological Club, 760, 799, 919  
BOWDITCH, H. P., Medical Education, 921  
BRANNER, J. C., Earth Sculpture, J. Geikie, 957  
Breeding of Animals at Woods Holl, May, 1898, H. C. BUMPUS, 58 ; June, July, August, 1898, H. C. BUMPUS, 850  
BRINTON, D. G., Current Notes on Anthropology, 16, 42, 71, 99, 126, 155, 180, 217, 260, 296, 328, 365, 407, 440, 474, 508, 545, 588, 626, 741, 787, 831, 862, 901, 948 ; The Study of Man, A. C. HADDON, 82 ; Brown Men and Women, E. REEVES, 111 ; Extinct Civilizations of the East, R. E. ANDERSON, 265 ; International Catalogue of Scientific Literature, 375

- British Association, 436; President's Address, SIR W. CROOKES, 561, 601
- BRITTON, E. G., Phytogeography of Nebraska, R. Pound and F. E. Clements, 53
- Britton, N. L., and Brown, A., Illustrated Flora of the U. S., Canada, etc., C. E. BESSEY, 195
- BROOKS, W. K., Zoology and the Philosophy of Evolution, 881
- BROOMALL, C. M., Stress-Strain Relations of Rubber, 673
- BROWN, E. W., Progress in Hydrodynamics, 641
- BRUSH, CHARLES F., A New Gas, 485
- BUMPUS, H. C., Breeding of Animals at Woods Holl, May, 1898, 58; June, July, August, 1898, 850; Biological Laboratory of the U. S. Fish Commission at Woods Holl, 96; Reappearance of the Tile-fish, 576; James Ingraham Peck, 783 [719]
- BURGESS, E. S., Torrey Botanical Club, 56, 83, 112, Burkhardt, H., and Meyer, W. F., *Mathematische Wissenschaften*, GEORGE BRUCE HALSTED, 907
- CALKINS, G. N., Biological Section of N. Y. Academy of Sciences, 679, 879
- Canker, An Apple, W. PADDOCK, 595, 836
- CARHART, H. S., Report of Committee on Standards of Measurement, 326
- Catalogue of Scientific Literature, D. G. BRINTON, 375; 589; A. TUCKERMANN, 752
- CATTELL, J. McKEEN, Memory, F. W. Edridge-Green, 111; Advance of Psychology, 533; *Physiologische Optik*, H. von Helmholtz, 794
- Celluloid Films, H. S. DAVIS, 163
- Cephalic Index, Curves, W. Z. RIPLEY, 578
- Cetaceans, Papier Maché Casts, F. W. TRUE, 108
- CHANDLER, S. C., Name for the New Planet, 672
- Chemical Society, Washington, W. H. KRUG, 26, 759; American, N. Y. Section, DURAND WOODMAN, 639, 759, 918; Journal, American, J. E. GLILPIN, 168, 959; Formulas, Abuse of, F. P. VENABLE, 732
- Chemistry. Inorganic, Notes, J. L. H., 181, 297, 328, 366, 439, 473, 506, 544, 585, 701, 740, 783, 899, 945; Applied, Third International Congress, FERDINAND G. WIECHMANN, 360; Physical, Progress in, T. W. RICHARDS, 721; Inorganic, Increasing Importance, H. C. JONES, 927
- Chicago Academy of Sciences, 182
- Christmas Island, 299
- Civil Service Examinations in Science, 19
- Classes, A., Quantitative Analysis, H. C. J., 598
- Cochineal, Lower Sonoran, T. D. A. COCKERELL, 675
- COCKERELL, T. D. A., Basil Valentine, 335; Life Zones in New Mexico, 635; Lower Sonoran Cochineal, 675; Instincts and Habits of Solitary Wasps, G. W. and E. G. Peckham, 876; and GARCIA, FABIAN, Growth of Plants in Gypsum, 119
- 'Coherer,' A Self-Readjusting, A. E. LAWRENCE, 836
- COLE, F. N., American Mathematical Society, 362, 717
- Color-Vision, C. LADD FRANKLIN, 23; FRANK P. WHITMAN, 305; C. L. F., 329
- COMSTOCK, G. C., The Day of the Week, 710
- Conant, F. S., The Cubomeduse, H. V. WILSON, 481
- CONKLIN, E. G., Problems of Biology, G. Sandemaun, 85
- Consumption, Prevention of, 330
- COOK, O. F., Stability in Nomenclature, 186; Method of Types, 513
- COOPER, H. C., The Nernst Light, 710
- Cope, Edward D., Memento of, C. S. MINOT, 113
- Coral-Boring Expedition to Funafuti, 73
- COULTER, JOHN M., Gymnosperms, 377
- CRAFTS, J. M., Greeting to the Boston Meeting of the American Association, 274
- CROOKES, SIR W., Address of President before British Association, 561, 601
- DALL, WM. H., Advances in Malacology, 612; Zoological Bibliography, 709, 955
- Dana, E. S., Mineralogy, A. J. M., 878
- Darwin, G. H., Tides, R. S. W., 911
- DAVENPORT, CHAS. B., Biomechanik, E. Meynert, 559; Fauna and Flora about Cold Spring Harbor, L. I., 685
- Davie, O., Nests and Eggs of North American Birds, F. A. L., 268
- DAVIS, H. S., Celluloid Films, 163
- DAVIS, W. M., Current Notes on Physiography, 40
- Day of the Week, E. L. STABLER, 594; G. C. COMSTOCK, 710
- Deep-sea Expedition, The German, 742
- Degrees, Honorary, Conferred by the University of Edinburgh, 261
- Delage, Y., Protoplasma, C. S. MINOT, 753
- Detner, W., Plant Physiology, J. C. ARTHUR, 597
- DEWAR, JAMES, Liquid Hydrogen, 3
- DEWEY, JOHN, Sense of Solidity, 675
- Dietary Studies, 73
- Discussion and Correspondence, 22, 108, 132, 161, 186, 223, 266, 302, 335, 371, 410, 479, 513, 551, 594, 634, 671, 707, 749, 793, 836, 872, 906, 953
- Distribution of Mammals, G. S. MILLER, JR., 615
- Doctorates Conferred by American Universities for Scientific Research, 197
- DORSEY, N. E., Physics at the American Association, 529
- Du Bois, A. J., Principles of Mechanics, R. S. W., 190
- Duss, R. P., Flore phanerogamique, 224
- Earthquakes, EDWARD S. HOLDEN, 294
- Edentates, Miocene, S. W. WILLISTON, 132
- Education, Report of Commissioner of, 1896-7, 78; Medical, H. P. BOWDITCH, 921
- Edridge-Green, F. W., Memory, J. McKEEN CATTELL, 111
- Electric Current in Organic Chemistry, EDGAR F. SMITH, 413
- Electricity and Magnetism, Mathematical Theory of, A. G. WEBSTER, 803
- Elements, Chemical, in Relation to Heat, W. A. TILDEN, 114
- ELIOT, CHAS. W., Destructive and Constructive Energies of Our Government compared, 277
- Energies of Our Government, Destructive and Constructive, CHAS. W. ELIOT, 277
- Engler, A., Pflanzenfamilien, L. M. UNDERWOOD, 136
- Entomological Society of Washington, L. O. HOWARD, 638, 718, 917
- Entomologists, Economic, Association, C. L. MARLATT, 584
- Erdmann, H., Anorganische Chemie, E. R., 837
- Escarpments, Vetter, J. E. WOODMAN, 735
- Ether, Inertia as Manifestation of the, C. BARUS, 681
- Evolution, A Half Century of, A. S. PACKARD, 243, 285, 316

- F., C. L., Color Vision, 329  
F., W. S., Notes on Physics, 403, 472, 859  
FARLOW, W. G., Conception of Species, 423  
Fauna and Flora about Coldspring Harbor, L. L.,  
CHAS. B. DAVENPORT, 685  
'Feeling of being Stared at,' E. B. TUTCHENER, 895  
Fermentation without Living Cells and Synthetic  
Protein, H. W. WILEY, 893  
FERNOW, B. E., The N. Y. State College of Forestry,  
494  
Fishes of S. New England, H. M. SMITH, 543  
Flachat, Eugène, R. H. T., 14  
FLEXNER, SIMON, Special Pathological Anatomy, D-  
MacAlister and H. W. Cattell, 139; Bacteriologi-  
cal Notes, 406  
Flower, W. H., Essays on Museums, F. A. L., 411  
Forestry, N. Y. State College, B. E. FERNOW, 494;  
Association, American, Meeting, 471  
Fossils, Vertebrate, for National Museum, 43  
FRANKLIN, C. LADD, Color-Vision, 23  
Franklin Institute, The, 547.  
FREER, PAUL C., Science Education, 210  
Fuertes, J. H., Water and Public Health, W. P. MA-  
SON, 166  
G., J. E., Quantitative Chemical Analysis, E. F.  
Ladd, 81; Organic Chemistry, J. Wade, 715  
Gage, A. P., Physics, W. LE CONTE STEVENS, 912  
GARDINER, J., Science in Bureau of Education, 161  
Gas, A New, CHARLES F. BRUSH, 485  
Gases in the Atmosphere, New, 18  
Geikie, J., Earth Sculpture, J. C. BRANNER, 957  
Geologic Association, International Conference, E. D.  
PRESTON, 841  
Geographical, Society, National, W. J. M., 363; Con-  
gress, International, 864  
Geological, Conference, Harvard, J. M. BOUTWELL,  
560, 680; Survey, Bulletin, W. F. M., 742; Club,  
Harvard, J. M. BOUTWELL, 760, 799, 919  
Geology of Jamaica, O. H. HERSHEY, 154  
GIBBS, WOLCOTT, President's Address before the  
American Association, 233  
GILL, THEO., Tailless Batrachians, 932  
GILPIN, J. E., Amer. Chemical Journal, 168, 959.  
Glaciers, Northern Rocky Mountain, G. B. GRIN-  
NELL, 711  
Goebel, K., Organographie der Pflanzen, C. MAC-  
MILAN, 23  
GORDON, R., N. Y. Acad. of Sciences, Physics, 960  
GRATACAP, L. P., Natural History Museums, 29, 61  
Gray, A., Magnetism and Electricity, J. TROW-  
BRIDGE, 109  
GRINNELL, G. B., Rocky Mountain Glaciers, 711  
Grotto, An American Blue, H. CARRINGTON BOLTON,  
266  
Growth of Plants in Gypsum, T. D. A. COCKERELL  
and FABIAN GARCIA, 119  
Gymnosperms and the Seed Habit, JOHN M. COULTER,  
377  
H., J. L., Notes on Inorganic Chemistry, 181, 297,  
322, 366, 439, 473, 506, 544, 585, 701, 740, 783,  
899, 945. [82  
Haddon, A. C., The Study of Man, D. G. BRINTON,  
Halévy, E., Théorie des sciences, P. SHOREY, 302  
HALLOCK, W., Hydraulic Illustration of the Wheat-  
stone Bridge, 206  
HALSTED, GEORGE BRUCE, Mathematische Wissen-  
schaften, H. Burkhardt and W. F. Meyer, 907  
HARRINGTON, N. R., Senff Zoological Expedition,  
541  
HAY, O. P., George Baur, 68  
HAYFORD, J. F., Tidal Problem, 810  
Heat of Metals, Specific, C. C. TROWBRIDGE, 6  
Helmholtz, H. von, Physiologische Optik, J. Mc-  
KEEN CATTELL, 794  
HENSHAW, S., Boston Society of Natural History,  
799, 960  
HERDMAN, W. A., The Bipolarity Hypothesis, 707  
HERRICK, C. L., Nervous Connection, 108  
HERSHEY, O. H., Geology of Jamaica, 154; Raised  
Shore-lines, 179  
Hertwig, O., Die Zelle und die Gewebe, F. R. LILLIE,  
517  
HOLDEN, EDWARD S., Earthquakes, 294  
HOLMES, W. H., Omaha Anthropological Exhibit, 37  
HOWARD, L. O., Entomological Society of Wash-  
ington, 638, 718, 917  
'Humane' Society, The, 863; Men of Science and,  
H. C. MERCER, 873  
HUSSEY, W. J., Minor Planet DQ, 673  
HYDE, J., Variations in Rate of Agricultural Pro-  
duction, 575  
Hydrodynamics, Progress in, E. W. BROWN, 641  
Hydrogen, Liquid, JAMES DEWAR, 3  
HYSLOP, J. H., La certitude logique, G. Milhaud; Le  
rational, G. Milhaud, 224  
Illusion, An Optical, F. C. KENYON, 371; Wind-  
mill, A. H. PIERCE, 479; JOSEPH LE CONTE, 480  
Illusions, Geometrical Optical, A. H. PIERCE, 814  
Inoculation against Plague, Preventive, 127  
Insects, Ordinarily Common, Occurrence in Great  
Abundance, F. C. KENYON, 551  
J., H. C., Quantitative Chemical Analysis by Electro-  
lysis, A. Classen, 598; Electro-chemistry, F.  
Oettel, 598; Elektrochemie, F. Peters, 637  
JACKMAN, WILBUR S., Nature Study, L. L. Wilson,  
446  
JACKSON, R. T., Zoological Section of the American  
Association, 395  
JAMES, WILLIAM, Telepathic Problem, 956  
JASTROW, J., La fatigue intellectuelle, A. Binet et  
V. Henri, 132  
Jays, Blue, Observations on, H. M. STANLEY, 223  
JENNINGS, H. S., Trochosphæra, 551  
JONES, H. C., Chimie physique, J. H. Van't Hoff,  
914; Importance of Inorganic Chemistry, 927  
Jordan, D. S., Footnotes to Evolution, A. S. PACK-  
ARD, 956  
Jurassic Formation on the Atlantic Coast, O. C.  
MARSH, 145  
KENYON, F. C., An Optical Illusion, 371; Occur-  
rence in Great Abundance of Insects Ordinarily  
Merely Common, 551; Eggs of the Sea-Urchin,  
829  
Kinetic Theory of Gases, WILLIAM RAMSAY, 768  
Kingsley, J. S., Comparative Zoology, F. E. LLOYD,  
53  
Kites at Blue Hill Observatory, 330  
Klein, F., und Sommerfeld, A., Theorie des Kreisels,  
R. S. W., 190  
KRUG, W. H., Chemical Society of Washington, 26,  
759  
L., E., Photography, A. T. Story, 959



- L., F. A., Zoological Notes, 96, 296, 474, 625, 860 ; Taxidermy, J. Rowley, 165 ; Delusion of Atavism, 267 ; Nests and Eggs of North American Birds, O. Davie, 268 ; Essays on Museums, W. H. Flower, 411
- Ladd, E. F., Quantitative Analysis, J. E. G., 81
- Lafar, F., Technical Mycology, H. L. RUSSELL, 267.
- Laisant, C. A., La mathématique, A. MACFARLANE, 51
- Language Study, J. MARK BALDWIN, 94
- Lassar-Cohn, Chemie in Täglichen Leben, FERDINAND G. WIECHMANN, 715
- LAWRENCE, A. E., A Self-readjusting 'Coherer,' 836
- LE CONTE, JOSEPH, The Windmill Illusion, 480
- LIBBEY, WILLIAM, Au Pays des ba-Rotsi, A. Bertrand, 163 ; The Philippines, D. C. Worcester, 755
- Life Zones in New Mexico, T. D. A. COCKERELL, 635 ; C. HART MERRIAM, 636
- LILLIE, F. R., Die Zelle und die Gewebe, O. Hertwig, 517
- LINDENKOHL, A., Salinity and Temperature of the Pacific Ocean, 941 [53
- LLOYD, F. E., Comparative Zoology, J. S. Kingsley, 106
- LOPER, S. W., Tertiary Formations of Wyoming and Colorado, 751
- Loubat Prizes, Award of, H. T. PECK, D. G. BRINTON, W. J. MCGEE, 18
- LUCAS, F. A., Biological Society of Washington, 678, 717, 799, 918
- M., Free Expansion of Gases, J. S. Ames, 675
- M., A. J., Mineralogy, E. S. Dana, 878
- M., M., Prismatical Formulae, T. U. Taylor, 677
- M., W. F., Geological Survey, Bulletin, 742
- M, W. J., National Geographic Society, 363 ; Wind Deposits, J. A. Udden, 835
- MaoAlister, D., and H. W. Cattell, Special Pathological Anatomy, SIMON FLENNER, 139
- MACFARLANE, A., La mathématique, C. A. Laisant, 51
- MACMILLAN, C., Organographie der Pflanzen, K. Goebel, 23 ; Botany, G. F. Atkinson, 796
- Magnetism, Terrestrial, International Conference, C. A. SCHOTT, 582
- Malacology, Advances in, WM. H. DALL, 612
- Mammals, Origin of, O. C. MARSH, 953
- MANN, C. R., The Echelon Spectroscope, 208
- MARE, E. L., Studies from the Harvard Zoological Laboratory, 176
- MARLATT, C. L., Association of Economic Entomologists, 584
- MARSH, O. C., Jurassic Formation on the Atlantic Coast, 145 ; Origin of Mammals, 953
- MASON, O. T., Pre-Columbian Music, 374
- MASON, W. P., Water and Public Health, J. H. Fuertes, 166
- Mathematical Society, American, Bulletin, 225 ; F. N. COLE, 360, 717
- Mathews, J. A., Metallic Carbides, H. C. B., 110
- MEAD, A. D., Peridinium and the 'Red Water' in Narragansett Bay, 707
- Measurements of Precision, X, 634 ; A. G. WEBSTER, 749
- Medicine, History of, Exhibit, 128
- MERCER, H. C., Men of Science and the Humane Society, 873
- MERRIAM, C. HART, Life Zones in New Mexico, 636 ; New Name for *Spermophilus brevicaudus*, *Canis pallidus*, *Sorex caudatus*, Merriam, 782
- Metargon, Spectrum of, 100
- Meteorology, Current Notes on, R. DEC. WARD, 15, 42, 97, 259, 405, 507, 665, 785, 947
- Meynert, E., Biomechanik, C. B. DAVENPORT, 559
- Milhaud, G., La certitude logique ; Le rational, J. H. HYSLOP, 224
- MILLER, JR., G. S., Local Temperature Control of Distribution of Mammals, 615
- Mills, W., Animal Intelligence, E. L. THORNDIKE, 520
- Minet, Ad., L'electro-chimie, E. F. SMITH, 80 ; Electro-Metallurgie, E. F. SMITH, 81
- MINOT, CHARLES SEDGWICK, Memento of Professor Edward D. Cope, 113 ; La structure du protoplasma, Y. Delage, 753 ; Anlage or Proton ? 906 ; Storing of Pamphlets, 944
- Moore, V. A., Bacteriology, W. H. PARK, 915
- Mouse, Georgia old field, New Name, OUTRAM BANGS, 214
- MURDOCH, J., Is the Beach Pea Food or Poison ? 907
- Museums, Natural History, L. P. GRATACAP, 29, 61 ; of British Columbia, H. I. SMITH, 619
- Music, Pre-Columbian, O. T. MASON, 371
- N., F. E., Electrical Measurement, W. A. Anthony, 838
- Names, New for *Spermophilus brevicaudus*, *Canis pallidus*, *Sorex caudatus*, Merriam, C. HART MERRIAM, 782 ; for *Microtus insularis*, Bailey, VERNON BAILEY, 782 ; for *Sciurus alpinus quercinus*, Nelson, E. W. NELSON, 783
- National Academy of Sciences, 758
- National Museum, Lacoe Collection in, 213
- Naturalists and Affiliated Societies, 627
- 'Naturforscher und Aertzte,' The German, 628
- Navy, Applied Science in the, R. H. THURSTON, 801
- NELSON, E. W., New Name for *Sciurus alpinus quercinus*, Nelson, 783 ; What is *Sciurus variegatus* Erxleben ? 897.
- Nernst Lamp, The, H. M. SMITH. 689 ; H. C. COOPER, 710
- Nervous Connection, C. L. HERRICK, 108
- New Books, 28, 84, 112, 140, 196, 268, 304, 340, 376, 412, 448, 484, 560, 600, 640, 680, 720, 760, 800, 840, 920, 960
- NEWCOMB, SIMON, An Unusual Aurora, 410
- New York Acad. of Sciences, Biology, G. N. CALKINS, 679, 879 ; Geology and Mineralogy, 839 ; Psychology and Anthropology, C. B. BLISS, 919 ; Physics, R. GORDON, 960
- NOLAN, E. J., Philadelphia Academy of Sciences, 27, 56, 111, 196
- NORTON, J. B. S., Engelmann Botanical Club, 84, 196
- Nomenclature, Generic, Stability in, O. F. COOK, 186
- Noyes, A. A., and S. P. Mulliken, Class Reactions and Identification of Organic Substances, W. A. NOYES, 167
- NOYES, W. A., Atoms in Space, J. H. Van't Hoff, 167 ; Class Reactions and Identification of Organic Substances, A. A. Noyes and S. P. Mulliken, 167
- O., H. F., Senff Zoological Expedition, 541
- Oettel, F., Electro-chemistry, H. C. J., 598
- Oppenheim, Development of the Child, M. V. O'SHEA, 556

- Ova, Fish, for Educational Purposes, H. M. SMITH, 671
- Ornithologists' Union, American, J. F. SAGE, 830
- ORTMANN, A. E., Supposed Bipolarity of Polar Faunas, 516
- OSGOOD, W. H., Four-footed Americans, M. O. Wright, 877
- O'SHEA, M. V., Recent Literature on Child-study, 552
- Ouranomba, Leidy's Genus, W. L. POTEAU, 778
- Oyster, Life Conditions of the, 736
- PACKARD, A. S., A Half Century of Evolution, 243' 285, 316; Charles Darwin and the Theory of Natural Selection, E. B. Poulton, 752; Footnotes to Evolution, D. S. Jordan, 956
- PADDOCK, W., An Apple Canker, 595, 836
- Pamphlets, Storing, CHARLES S. MINOT, 944
- PARK, W. H., Bacteriology, V. A. Moore, 915
- Pea, Beach, Food or Poison? J. MURDOCH, 907
- Peabody, C. H., Thermodynamics of the Steam Engine, R. H. THURSTON, 676
- PECK, H. T., BRINTON, D. G., MCGEE, W. J., Award of Loubat Prizes, 18
- Peck, James Ingraham, H. C. BUMPUS, 783
- Peckham, G. W., and E. G., Instincts and Habits of Solitary Wasps, T. D. A. COCKERELL, 876
- Peridinium and the 'Red Water' in Narragansett Bay, A. D. MEAD, 707
- Perry, J., Applied Mechanics, R. S. W., 190
- Personal Equations, Century of, J. H. SAFFORD, 727
- Peters, F., Elektrochemie, H. C. J., 637
- Philadelphia, Academy of Sciences, E. J. NOLAN, 27, 56, 111, 196
- Philosophical Society of Washington, E. D. PRESTON, 880, 959
- Photography in Astronomy, E. E. BARNARD, 341, 356
- Photometer, The Flicker, FRANK P. WHITMAN, 11
- Physical Laboratory, National, for Great Britain, 546
- Physics, Notes on, W. S. F., 403, 472, 859
- Physiography, Current Notes on, W. M. DAVIS, 40
- Physiological Effects of Lack of Oxygen, High Temperature and Certain Poisons, W. ZOETHOUT, 776
- PIERCE, A. H., The Windmill Illusion, 479; Geometrical Optical Illusions, 814
- PIERCE, C. S., Age of Basil Valentine, 169
- Plague, Professor Koch on the, 101
- Planet, Name for New, S. C. CHANDLER, 672; Minor, DQ, W. J. HESSEY, 673
- POTEAU, W. L., Leidy's Genus Ouranomba, 778
- Poulton, E. B., Charles Darwin, A. S. PACKARD, 752
- Pound, R., and Clements, F. E., Phytogeography of Nebraska, E. G. BRITTON, 53
- PRESTON, E. D., International Conference of Geodetic Association, 811; Philosophical Society of Washington, 880, 959
- PROSSER, W. S., The Endowment of American Archaeology, 675
- Psychology, Advance of, J. MCKEEN CATTELL, 533
- Quadratic Cremona, Transformations of the Plane, H. E. SLAUGHT, 121
- R., E., Inorganic Chemistry, F. P. Venable and J. L. Howe, 754; Anorganische Chemie, H. Erdmann' 837
- RAMSAY, W., A New Constituent of Air, 1; Kinetic Theory of Gases, 768
- Reeves, E., Brown Men and Women, D. G. BRINTON, 111
- RENOUF, E., Qualitative Analysis, H. L. Wells, Inorganic Qualitative Analysis, J. S. C. Wells, 878
- RICHARDS, T. W., Progress in Physical Chemistry, 721
- RIPLEY, W. Z., Curves of Cephalic Index, 578
- Routh, E. J., Analytical Statics, R. S. W., 190
- Rowley, J., Art of Taxidermy, F. A. L., 165
- Rubber, Stress-Strain Relations of, C. M. BROOMALL, 673
- RUSSELL, H. L., Technical Mycology, F. Lafar, 267
- RUSSELL, ISRAEL C., The Earth's History, N. S. Shaler, 712
- St. Louis Academy of Sciences, WM. TRELEASE, 720, 920
- SAFFORD, T. H., Century of Personal Equations, 727
- SAGE, J. F., Ornithologists' Union, 830
- Salinity and Temperature of the Pacific Ocean, A. LINDENKOHLE, 941
- Sandemann, G., Problems of Biology, E. G. CONKLIN, 85
- Sanford, E. C., Experimental Psychology, E. W. SCRIPTURE, 24
- SCHOTT, C. A., International Conference on Terrestrial Magnetism, 582
- SCHRENK, H. VON, Engelmann Botanical Club, 639
- Science and Industrial Supremacy, 75
- Science, Teachers' Conference, C. E. BESSEY, 123; in Bureau of Education, J. GARDINER, 161; Education, P. C. FREER, 210
- Scientific, Notes and News, 17, 43, 72, 99, 127, 156, 182, 218, 261, 298, 329, 367, 407, 441, 475, 508, 546, 589, 627, 667, 703, 742, 788, 832, 863, 902, 949; Literature, 23, 51, 80, 109, 132, 163, 190, 224, 267, 302, 335, 372, 411, 446, 481, 517, 552, 597, 637, 675, 712, 752, 794, 837, 874, 907, 956; Conference, 660; Journals, 25, 55, 82, 168, 195, 225, 340, 376, 484, 560, 599, 638, 678, 716, 758, 798, 839, 879, 916, 959
- Sciurus variegatus Erxleben, What is? E. W. NELSON, 897
- SCRIPTURE, E. W., Experimental Psychology, E. C. Sanford, 24
- Seal Rookeries, Prifilof, C. H. TOWNSEND, 618
- Sea-urchin, Eggs, F. C. KENYON, 829
- Self, Early Sense of, H. M. STANLEY, 22
- Senf, Zoological Expedition, H. F. O., N. R. HARRINGTON, 541
- Seward, A. C., Fossil Plants, LESTER F. WARD, 335
- Shaler, N. S., The Earth's History, ISRAEL C. RUSSELL, 712
- Shore-lines on Cape Maysi, Cuba, Raised, O. H. HERSHEY, 179
- SHOREY, PAUL, Théorie des Sciences, E. Halévy, 302
- SIDIS, BORIS, Psychology of Suggestion, 162
- SLAUGHT, H. E., Cross-ratio Group of 120 Quadratic Cremona Transformations of the Plane, 121
- SMITH, E. A., Alabama Industrial and Scientific Society, 720
- SMITH, EDGAR F., L'Electro-chimie, Ad. Minet, 80; Electro-metallurgie, Ad. Minet, 81; Electric Current in Organic Chemistry, 413
- SMITH, ERWIN F., Botany at American Association, 651, 690
- SMITH, H. I., Natural History Museums of British Columbia, 619
- SMITH, H. M., Biological Survey of Lake Erie, 13; New Fishes of S. New England, 543; Fish Ova for Educational Purposes, 671

- SMITH, H. MONMOUTH, The Nernst Lamp, 689  
 SNYDER, M. B., Harvard Astrophysical Conference, 449  
 Societies and Academies, 26, 83, 111, 140, 168, 196, 226, 560, 638, 678, 717, 758, 799, 839, 879, 917, 959  
 Solidity, Sense of, JOHN DEWEY, 675  
 Species, Conception of, W. G. FARLOW, 423  
 Spectroscope, The Echelon, C. R. MANN, 208  
 STABLEY, E. L., A Day of the Week, 594  
 STANLEY, H. M., Early Sense of Self, 22; Observations on Blue Jays, 223 [764  
 Steam Engines, Thermal Efficiency, R. H. THURSTON, STEVENS, W. LE CONTE, Physics, S. P. GAGE, 912  
 Story, A. T., Photography, E. L., 959  
 STRONG, E. A., Grundprobleme der Naturwissenschaft, A. Wagner, 373  
 Suggestion, Psychology of, BORIS SIDIS, 162  
 Sully, J., Children's Ways, M. V. O'SHEA, 552  
 Surveys of the Gateways to Alaska, 700
- T., R. H., Eugène Flachat, 14; Air-brake Catechism, R. H. Blackall, 637  
 Tait, P. G., Dynamics, R. S. W., 190  
 Taylor, Study of the Child, M. V. O'SHEA, 554  
 Taylor, T. U., Prismoidal Formule, M. M., 677  
 Teaching, Laboratory, F. P. WHITMAN, 201  
 Telegraph and Telephone, Ownership, 864  
 Telegraphic Problem, WILLIAM JAMES, 956  
 Tertiary Formation, S. W. LOPER, 751 [520  
 THORNDIKE, E. L., Animal Intelligence, W. MILLS, THURSTON, R. H., Thermodynamics of the Steam Engine, C. H. Peabody, 676; Thermal Efficiency of Steam Engines, 764; Applied Science in the Navy, 801  
 Tidal Problem, Solution, J. F. HAYFORD, 810  
 TILDEN, W. A., Chemical Elements and Heat, 114  
 Tile-fish, Reappearance, H. C. BUMPUS, 576  
 TITCHENER, E. B., 'Being Stared At,' 895  
 TOSTI, G., Sociology, Lester F. Ward, 874  
 TOWNSEND, C. H., Pribilof Seal Rookeries, 618  
 TRELEASE, WM., St. Louis Academy of Sciences, 720, 920  
 Trochosphera again, H. S. JENNINGS, 551  
 TROWBRIDGE, C. C., Specific Heat of Metals, 6  
 TROWBRIDGE, J., Magnetism, A. Gray, 109  
 TRUE, A. C., Report of Secretary of Agriculture, 847; Association of Agricultural Colleges, 761  
 TRUE, F. W., Exhibitions of Cetaceans, 108  
 TUCKERMANN, A., Catalogue of Scientific Literature, 752  
 Types, The Method of, O. F. COOK, 513
- Udden, J. A., Wind Deposits, W. J. M., 838 [136  
 UNDERWOOD, L. M., Pflanzenfamilien, A. Engler, University and Educational News, 21, 51, 78, 107, 132, 161, 185, 223, 265, 301, 334, 370, 410, 446, 478, 512, 550, 594, 633, 670, 706, 748, 791, 835, 871 905 952
- UPHAM, WARREN, Geology at the American Association, 462, 501  
 UPTON, WINSLOW, Astronomical Notes, 623
- Valentiu, Basil, C. S. PIERCE, 169; T. D. A. COCKRELL, 335  
 Van't Hoff, J. H., Atoms in Space, W. A. NOYES, 167; Chimie physique, H. C. JONES, 914  
 VENABLE, F. P., Abuse of Chemical Formulas, 732  
 Venable, F. P., and J. L. Howe, Inorganic Chemistry, E. R., 754
- W., R. S., Recent Work on Mechanics, 190; Tides, G. H. Darwin, 911  
 Wade, J., Organic Chemistry, J. E. G., 715  
 Wagner, A., Grundprobleme der Naturwissenschaft, E. A. STRONG, 373  
 WALDO, F., Atmosphere, D. Archibald, 304  
 Wampum Belts, W. M. BEAUCHAMP, 596  
 WARD, LESTER F., Fossil Plants, A. C. Seward, 335  
 Ward, Lester F., Sociology, G. Tosti, 874  
 WARD, R. DE C., Current Notes on Meteorology, 15, 42, 97, 259, 405, 507, 665, 785, 947  
 Weather Service, Extension of, 99  
 WEBSTER, A. G., Measurements of Precision, 749; Theory of Electricity and Magnetism, 803  
 Wells, H. L., Qualitative Analysis, E. RENOUF, 878  
 Wells, J. S. C., Inorganic Qualitative Analysis, E. RENOUF, 878  
 Wheatstone Bridge, Illustration, W. HALLOCK, 206  
 WHITMAN, FRANK P., The Flicker Photometer, 11; Laboratory Teaching, 201; Color-Vision, 305  
 WIECHMANN, FERDINAND G., Third International Congress of Applied Chemistry, 360; Chemie in täglichen Leben, Lassar-Cohn, 715  
 WILDER, BURT G., Equivalent of 'Anlage,' 793  
 WILEY, H. W., Fermentation without Living Cells and Synthetic Protein, 893  
 WILLISTON, S. W., Miocene Edentates, 132  
 WILSON, H. V., The Cubomedusa, F. S. Conant, 481  
 Wilson, L. L., Nature Study, WILBUR S. JACKMAN, 446  
 WOODMAN, DURAND, N. Y. Section of American Chemical Society, 639, 759, 918  
 WOODMAN, J. E., Vetter Escarpments, 735  
 Worcester, D. C., Philippine Islands, W. LIBBEY, 755  
 Wright, M. O., Four-footed Americans, W. H. OSGOOD, 877  
 Wright, T. W., Mechanics, R. S. W., 190
- X., Measurements of Precision, 634
- ZOETHOUT, W., Physiological Effects of Lack of Oxygen, High Temperature and Certain Poisons, 776  
 Zoological, Notes, F. A. L., 96, 296, 474, 625, 860; Studies, Harvard, E. L. MARK, 176; Club, University of Chicago, 140  
 Zoology, International Congress, 353; and the Philo-zoophy of Evolution, W. K. BROOKS, 881.



# SCIENCE

EDITORIAL COMMITTEE: S. NEWCOMB, Mathematics; R. S. WOODWARD, Mechanics; E. C. PICKERING, Astronomy; T. C. MENDENHALL, Physics; R. H. THURSTON, Engineering; IRA REMSEN, Chemistry; J. LE CONTE, Geology; W. M. DAVIS, Physiography; O. C. MARSH, Paleontology; W. K. BROOKS, C. HART MERRIAM, Zoology; S. H. SCUDDER, Entomology; C. E. BESSEY, N. L. BRITTON, Botany; HENRY F. OSBORN, General Biology; C. S. MINOT, Embryology, Histology; H. P. BOWDITCH, Physiology; J. S. BILLINGS, Hygiene; J. McKEEN CATTELL, Psychology; DANIEL G. BRINTON, J. W. POWELL, Anthropology.

FRIDAY, JULY 1, 1898.

## CONTENTS:

<i>A New Constituent of Atmospheric Air:</i> PROFESSOR WILLIAM RAMSAY.....	1
<i>Liquid Hydrogen:—</i>	
<i>Preliminary Note on the Liquefaction of Hydrogen and Helium; The Boiling Point and Density of Liquid Hydrogen:</i> PROFESSOR JAMES DEWAR..	3
<i>The Specific Heat of Metals at Low Temperatures:</i> C. C. TROWBRIDGE.....	6
<i>The Flicker Photometer:</i> PROFESSOR FRANK P. WHITMAN.....	11
<i>Biological Survey of Lake Erie:</i> H. M. SMITH.....	13
<i>Eugène Flachet:</i> R. H. T.....	14
<i>Current Notes on Meteorology:—</i>	
<i>Mohn's Grundzüge der Meteorologie; Van Eeber's Wettervorhersage: The Climate of Cuba:</i> R. DEC. WARD.....	15
<i>Current Notes on Anthropology:—</i>	
<i>The Building Sacrifice; The Custom of Dharna:</i> PROFESSOR D. G. BRINTON.....	16
<i>Scientific Notes and News:—</i>	
<i>Meeting of the American Association; Award of the Loubal Prizes; New Gases in the Atmosphere; The Civil Service Examinations in Science; General.....</i>	17
<i>University and Educational News.....</i>	21
<i>Discussion and Correspondence:—</i>	
<i>On the Early Sense of Self:</i> PROFESSOR HIRAM M. STANLEY. <i>Color Vision:</i> C. LADD FRANKLIN.....	22
<i>Scientific Literature:—</i>	
<i>Goebel's Organographie der Pflanzen:</i> PROFESSOR CONWAY MACMILLAN. <i>Sanford's Course in Experimental Psychology:</i> DR. E. W. SCRIPTURE.....	23
<i>Scientific Journals.....</i>	25
<i>Societies and Academies:—</i>	
<i>The Philadelphia Academy of Natural Sciences:</i> DR. E. J. NOLAN. <i>The Chemical Society of Washington:</i> WILLIAM A. KRUG.....	26
<i>New Books.....</i>	28

## ON A NEW CONSTITUENT OF ATMOSPHERIC AIR.\*

THIS preliminary note is intended to give a very brief account of experiments which have been carried out during the past year to ascertain whether, in addition to nitrogen, oxygen and argon, there are any gases in air which have escaped observation owing to their being present in very minute quantity. In collaboration with Miss Emily Aston we have found that the nitride of magnesium, resulting from the absorption of nitrogen from atmospheric air, on treatment with water yields only a trace of gas; that gas is hydrogen, and arises from a small quantity of metallic magnesium unconverted into nitride. That the ammonia produced on treatment with water is pure has already been proved by the fact that Lord Rayleigh found that the nitrogen produced from it had the normal density. The magnesia, resulting from the nitride, yields only a trace of soluble matter to water, and that consists wholly of hydroxide and carbonate. So far, then, the results have been negative.

Recently, however, owing to the kindness of Dr. Hampson, we have been furnished with about 750 cubic centimeters of liquid air, and, on allowing all but 10 cubic centimeters to evaporate away slowly, and, col-

\*Paper read before the Royal Society on June 9th by Professor William Ramsay, F. R. S., and Morris W. Travers. Received by the Society June 3d. Reprinted from *Nature*.

MSS. intended for publication and books, etc., intended for review should be sent to the responsible editor, Professor J. McKeen Cattell, Garrison-on-Hudson, N. Y.

lecting the gas from that small residue in a gas holder, we obtained, after removal of oxygen with metallic copper and nitrogen with a mixture of pure lime and magnesium dust, followed by exposure to electric sparks in presence of oxygen and caustic soda, 26.2 cubic centimeters of a gas, showing the argon spectrum feebly, and, in addition, a spectrum which has, we believe, not been seen before.

We have not yet succeeded in disentangling the new spectrum completely from the argon spectrum, but it is characterized by two very brilliant lines, one almost identical in position with  $D_3$ , and almost rivalling it in brilliancy. Measurements made with a grating of 14,438 lines to the inch, kindly placed at our disposal by Mr. E. C. C. Baly, gave the following numbers, *all four lines being in the field at once*:

$D_1$	...	...	5895.0
$D_2$	...	...	5889.0
$D_3$	...	...	5875.9
$D_4$	...	...	5866.65 + 1.7 to correct to vacuum.

There is also a green line, comparable with the green helium line in intensity, of wave-length 5566.3, and a somewhat weaker green, the wave-length of which is 5557.3.

In order to determine, as far as possible, which lines belong to the argon spectrum, and which to the new gas, both spectra were examined at the same time with the grating, the first order being employed. The lines which were absent, or very feeble, in argon have been ascribed to the new gas. Owing to their feeble intensity, the measurements of the wave-lengths which follow must not be credited with the same degree of accuracy as the three already given, but the first three digits may be taken as substantially correct:

Violet	...	..	4317	Blue	...	...	4834
"	...	...	4387	"	...	...	4909
"	...	...	4461	Green	...	...	5557.3
"	...	...	4671	"	...	...	5566.3
Blue	...	...	4736	Yellow	...	...	5829
"	...	...	4807	"	...	...	5866.5
"	...	...	4830	Orange	...	...	6011

Mr. Baly has kindly undertaken to make a study of the spectrum, which will be published when complete. The figures already given, however, suffice to characterise the gas as a new one.

The approximate density of the gas was determined by weighing it in a bulb of 32.321 cubic centimeters' capacity, under a pressure of 521.85 millimeters, and at a temperature of 15.95°. The weight of this quantity was 0.04213 gram. This implies a density of 22.47, that of oxygen being taken as 16. A second determination, after sparking for four hours with oxygen in presence of soda, was made in the same bulb; the pressure was 523.7 millimeters, and temperature was 16.45°. The weight was 0.04228 gram, which implies the density 22.51.

The wave-length of sound was determined in the gas by the method described in the 'Argon' paper. The data are:

			i.	ii.	iii.
Wave-length in air	...	...	34.17	34.30	34.57
"	"	gas	29.87	30.13	

Calculating by the formula

$$\lambda_{\text{air}}^2 \times \text{density}_{\text{air}} : \lambda_{\text{gas}}^2 \times \text{density}_{\text{gas}} :: \gamma_{\text{air}} : \gamma_{\text{gas}}$$

$$(34.33)^2 \times 14.479 : (30)^2 \times 22.47 :: 1.408 : 1.666$$

it is seen that, like argon and helium, the new gas is monatomic and therefore an element.

From what has preceded, it may be concluded that the atmosphere contains a hitherto undiscovered gas with a characteristic spectrum, heavier than argon, and less volatile than nitrogen, oxygen and argon; the ratio of its specific heats would lead to the inference that it is monatomic and therefore an element. If this conclusion turns out to be well substantiated we propose to call it 'krypton,' or 'concealed.' Its symbol would then be Kr.

It is, of course, impossible to state positively what position in the periodic table this new constituent of our atmosphere will



occupy. The number 22.51 must be taken as a minimum density. If we may hazard a conjecture it is that krypton will turn out to have the density 40, with a corresponding atomic weight 80, and will be found to belong to the helium series, as is, indeed, rendered probable by its withstanding the action of red-hot magnesium and calcium on the one hand, and on the other of oxygen in presence of caustic soda, under the influence of electric sparks. We shall procure a larger supply of the gas and endeavor to separate it more completely from argon by fractional distillation.

It may be remarked in passing that Messrs. Kayser and Friedlander, who supposed that they had observed  $D_8$  in the argon of the atmosphere, have probably been misled by the close proximity of the brilliant yellow line of krypton to the helium line.

On the assumption of the truth of Dr. Johnstone Stoney's hypothesis that gases of a higher density than ammonia will be found in our atmosphere, it is by no means improbable that a gas lighter than nitrogen will also be found in air. We have already spent several months in preparation for a search for it, and will be able to state ere long whether the supposition is well founded.

#### LIQUID HYDROGEN.

##### PRELIMINARY NOTE ON THE LIQUEFACTION OF HYDROGEN AND HELIUM.\*

In a paper entitled 'The Liquefaction of Air and Research at Low temperatures,' read before the Chemical Society, and published in their 'Proceedings,' No. 158, an account is given of the history of the hydrogen problem and the result of my own experiments up to the end of the year 1895. The subject is again discussed in a Friday Evening Lecture on 'New Researches on

\*Read before the Royal Society, London, May 12, 1898.

Liquid Air,\* which contains a drawing of the apparatus employed for the production of a jet of hydrogen containing liquid. It was shown that such a jet could be used to cool bodies below the temperature that could be reached by the use of liquid air, but all attempts to collect the liquid in vacuum vessels failed. No other investigator has so far improved on the results described in 1895. The type of apparatus used in these experiments worked well, so it was resolved to construct a much larger liquid air plant, and to combine with it circuits and arrangements for the liquefaction of hydrogen, which will be described in a subsequent paper. This apparatus, admirably constructed by the engineers, Messrs. Lennox, Reynolds, and Fyfe, took a year to build up, and many months have been occupied in testing and making preliminary trials. The many failures and defeats need not be detailed.

On May 10th, starting with hydrogen cooled to  $-205^{\circ}$  C., and under a pressure of 180 atmospheres, escaping continuously from the nozzle of a coil of pipe at the rate of about 10 cubic feet to 15 cubic feet per minute, in a vacuum vessel double-silvered and of special construction, all surrounded with a space kept below  $-200^{\circ}$  C., liquid hydrogen commenced to drop from this vacuum vessel into another doubly isolated by being surrounded with a third vacuum vessel. In about five minutes, 20 cc. of liquid hydrogen were collected, when the hydrogen jet froze up from the solidification of air in the pipes. The yield of liquid was about 1 per cent. of the gas. The hydrogen in the liquid condition is clear and colorless, showing no absorption spectrum, and the meniscus is as well defined as in the case of liquid air. The liquid has a relatively high refractive index and dispersion, and the density appears to be in excess of the theoretical density, viz., 0.18 to 0.12, which we

\*'Roy. Inst. Proc.,' 1886.

deduce respectively from the atomic volume of organic compounds and the limiting density found by Amagat for hydrogen gas under infinite compression. My old experiments on the density of hydrogen in palladium gave a value for the combined body of 0.62, and it will be interesting to find the real density of the liquid substance at its boiling point. Not having arrangements at hand to determine the boiling point, two experiments were made to prove the excessively low temperature of the boiling fluid. In the first place, if a long piece of glass tubing, sealed at one end and open to the air at the other, is cooled by immersing the closed end in the liquid hydrogen, the tube immediately fills, where it is cooled, with solid air. The second experiment was made with a tube containing helium.

The 'Cracow Academy Bulletin' for 1896 contains a paper by Professor Olszewski, entitled 'A Research on the Liquefaction of Helium,' in which he states 'as far as my experiments go, helium remains a permanent gas and apparently is much more difficult to liquefy than hydrogen.' In a paper of my own in the 'Proceedings of the Chemical Society,' No. 183 (1896-7), in which the separation of helium from Bath gas was effected by a liquefaction method, the suggestion was made that the volatility of hydrogen and helium would probably be found close together, just like those of fluorine and oxygen. Having a specimen of helium which had been extracted from Bath gas, sealed up in a bulb with a narrow tube attached, the latter was placed in liquid hydrogen, when a distinct liquid was seen to condense. A similar experiment made with the use of liquid air under exhaustion in the same helium tube (instead of liquid hydrogen) gave no visible condensation. From this result it would appear that there cannot be any great difference in the boiling points of helium and hydrogen.

All known gases have now been condensed into liquids which can be manipulated at their boiling points under atmospheric pressure in suitably arranged vacuum vessels. With hydrogen as a cooling agent we shall get within 20° or 30° of the zero of absolute temperature, and its use will open up an entirely new field of scientific inquiry. Even as great a man as James Clerk Maxwell had doubts as to the possibility of ever liquefying hydrogen.\* No one can predict the properties of matter near the zero of temperature. Faraday liquefied chlorine in the year 1823. Sixty years afterwards Wroblewski and Olszewski produced liquid air, and now, after a fifteen years' interval, the remaining gases, hydrogen and helium, appear as static liquids. Considering that the step from the liquefaction of air to that of hydrogen is relatively as great in the thermo-dynamic sense as that from liquid chlorine to liquid air, the fact that the former result has been achieved in one-fourth the time needed to accomplish the latter, proves the greatly accelerated rate of scientific progress in our time.

The efficient cultivation of this field of research depends upon combination and assistance of an exceptional kind; but in the first instance money must be available and the members of the Royal Institution deserve my especial gratitude for their handsome donations to the conduct of this research. Unfortunately its prosecution will demand a further large expenditure. The handsome contribution made by the Goldsmiths' Company ought also to be mentioned as very materially helping the progress of the work.

During the whole course of the low temperature work carried out at the Royal Institution the invaluable aid of Mr. Robert Lennox has been at my disposal; and it is not too much to say that but for his engi-

\* See 'Scientific Papers,' Vol. 2, p. 412.

neering skill, manipulative ability and loyal perseverance the present successful issue might have been indefinitely delayed. My thanks are also due to Mr. J. W. Heath for valuable assistance in the conduct of these experiments.

#### THE BOILING POINT AND DENSITY OF LIQUID HYDROGEN.\*

The boiling point of liquid hydrogen at atmospheric pressure has been determined by a platinum resistance thermometer. This was constructed of pure metal and had a resistance of 5.3 ohms at 0° C., which fell to about 0.1 ohm when the thermometer was immersed in liquid hydrogen. On reduction of this resistance to normal air temperatures the boiling point is found to be -238.2° and -238.9° respectively by two methods, and to be -237° by a Dickson formula calculated for this thermometer (*cf. Phil. Mag.*, 1898, 45, 525). The boiling point of the liquid is, therefore, about -238° C., or 35° absolute, and is thus about 5° higher than that obtained by Olszewski by the adiabatic expansion of the compressed gas, and about 8° higher than that deduced by Wroblewski from van der Waals' equation. It may be inferred that the critical point of hydrogen is about 50° absolute, and that the critical pressure will probably not exceed 15 atmospheres. As molecular latent heats are proportional to absolute boiling points, the latent heat of liquid hydrogen will be about two-fifths that of liquid oxygen. From analogy it is probable that the practicable lowering of temperature to be obtained by evaporating liquid hydrogen under pressures of a few mm. cannot amount to more than 10-12° C., and it may be said with certainty that no means are at present known for approaching nearer than 20-25° to the absolute zero of temperature. The platinum resistance thermometer used had

a zero point of -263.2 platinum degrees, and when immersed in boiling liquid hydrogen indicated a temperature of -256.8° on the same scale, or 6.4 platinum degrees from the point at which the metal would become a perfect conductor. The effect of cooling platinum from the boiling point of liquid oxygen to that of liquid hydrogen is to diminish its resistance to one-eleventh.

The approximate density of liquid hydrogen at its boiling point was determined by measuring the volume of the gas obtained by evaporating 10 cc. and is slightly less than 0.07, or about one-sixth that of liquid marsh gas, which has a density of 0.41 and is the lightest liquid at its boiling point hitherto known. It is remarkable that, with so low a density, liquid hydrogen is so easily seen, has so well defined a meniscus, and can be so readily collected and manipulated in vacuum vessels. As hydrogen occluded in palladium has a density of 0.62, it follows that it must be associated with the metal in some other state than that of liquefaction. The atomic volume of liquid hydrogen at the boiling point is about 14.3, atomic volumes of liquid oxygen and nitrogen being 13.7 and 16.6, respectively, at their boiling points. The density of the gas at the boiling point of liquid hydrogen is 0.55, or about one-half that of air, and is eight times that of the gas at ordinary temperatures. The ratio of the density of hydrogen gas at the boiling point to that of the liquid is approximately 1 : 100, as compared with a ratio of 1 : 255 in the case of oxygen.

The specific heat of hydrogen in the gaseous state and in hydrogenized palladium is 3.4, but may very probably be 6.4 in the liquid substance. Such a liquid would be unique in its properties, but as the volume of one gram of liquid hydrogen is about 14-15 cc. the specific heat per unit volume must be nearly 0.5, which is about that of liquid air. It is highly pro-

\*Read before the Chemical Society, London, on June 2, 1898.



bable, therefore, that the remarkable properties of liquid hydrogen predicted by theory will prove to be susceptible of explanation when they are compared with those of liquid air, volume for volume, at corresponding temperatures as defined by van der Waals.

JAMES DEWAR.

ROYAL INSTITUTION, LONDON.

*THE SPECIFIC HEAT OF METALS AT LOW TEMPERATURES.*

DR. WOLCOTT GIBBS having requested Professor Rood to make some determinations of the specific heat of a few metals, employing liquid air, the matter was finally handed over to me by Professor Rood, and I herewith give a short account of the method used and the results obtained.

Few experiments on the specific heat of substances at low temperatures have been made. The chief cause of this has been the difficulty experienced heretofore in reducing the temperature of bodies to a definite number of degrees sufficiently below zero, Centigrade. Liquid air affords a means of obtaining a very low temperature, and was procured through the kindness of Mr. Charles E. Tripler, who has devised apparatus for making it in considerable quantities.

In a paper on the liquefaction of gases by Professor Charles Olszewski, in the *Philosophical Magazine*, London, February, 1895, Vol. XXXIX., No. CCXXXVII., pp. 188-212, it is stated, that the boiling point of liquefied air under atmospheric pressure is  $-191.4^{\circ}\text{C}$ ., that of liquefied nitrogen  $-194.4^{\circ}\text{C}$ ., and that of liquefied oxygen  $-181.4^{\circ}\text{C}$ .. These temperatures were determined with a hydrogen thermometer, and are generally accepted as correct.

Liquefied air changes in composition when in a state of ebullition, the percentage of nitrogen contained in it diminishing, while that of oxygen increases.

This change occurs because liquid nitrogen is the more volatile of the two liquid gases, and boils away at a higher rate than liquid oxygen; consequently liquid air changes in temperature. If it is allowed to boil for a considerable time it becomes almost pure liquid oxygen and its temperature correspondingly approaches near the boiling point of that liquid gas, or  $-181.4^{\circ}\text{C}$ ..

Such was the case with the liquefied air procured for the experiments on specific heat; therefore, after standing several hours, the cold liquid employed by me was considered to be liquid oxygen and its temperature  $-181.4^{\circ}\text{C}$ ..

A series of determinations were made of the specific heat of copper, iron and aluminium between the boiling point of liquid oxygen ( $-181.4^{\circ}\text{C}$ .) and about 13 degrees Centigrade.

The method of mixtures was employed and was applied in a manner suggested by Professor Rood.

The experiments were conducted as follows:

A piece of metal of known weight was immersed in liquid oxygen ( $-181.4^{\circ}\text{C}$ .); after it had cooled down to the temperature of the liquid, it was lifted out by a silk thread attached to it, and transferred quickly to a calorimeter containing water of known weight and temperature.

The loss in temperature of the water, due to the insertion of the cold substance, was carefully noted, and the specific heat of the metal computed.

Various precautions were taken to avoid errors in the results, and the usual corrections were applied in the calculations.

Before the determinations of the specific heat of metals between the boiling point of liquid oxygen and normal temperatures (about  $13^{\circ}\text{C}$ .) were begun, a series of experiments were performed on the specific heat of copper between  $23^{\circ}\text{C}$ . and the boiling point of water ( $100^{\circ}\text{C}$ .), under condi-

tions as far as possible identical with those anticipated in the experiments with liquid oxygen.

By this means it was ascertained approximately what degree of accuracy could be expected in the results when liquid oxygen was employed.

The manipulation in these preliminary experiments was as follows:

A piece of copper, with a silk thread attached (the identical piece to be used in the low temperature experiments), was immersed in boiling water and allowed to remain submerged for several minutes.

It was then lifted out of the boiling water by the thread, and conveyed as quickly as possible to a calorimeter two-thirds filled with water at 17°C. The rise in the temperature of the water was noted, and the specific heat calculated in the usual way. When the copper was transferred from the vessel containing the boiling water to the calorimeter, it was allowed to strike the edge of the vessel a sharp blow to remove drops of water remaining on the surface of the piece of copper.

It was found, however, that a small amount of hot water, .03 to .04 of a gram, was always carried over to the calorimeter. The quantity was determined experimentally and the proper correction applied in the specific heat calculations.

Five consecutive determinations of the specific heat of copper between 23° C. and the boiling point of water (100° C.), by this method, were as follows:

TABLE 1.

Substance.	Determination Number.	Specific Heat. 23°...100° C.
Copper.	1	.09262
"	2	.09463
"	3	.09399
"	4	.09394
"	5	.09517
	Mean	.0940

Average variation of the five determinations from the mean .0006, or .7 per cent.

Greatest variation of any one determination from the mean, .00138, or 1.5 per cent.

The weight of water used in each determination was 70.00 grams, and the water equivalent of the calorimeter and thermometer, 5.87 grams.

The weight of copper employed in each determination was 63.493 grams.

The temperature of the boiling water was determined from the atmospheric pressure, the barometric height being measured at intervals during the experiments.

The mean value obtained for the specific heat of copper, .0940, is in agreement with the value generally accepted for that metal for the same range of temperature, the best values ranging from .0933 to .0949.

Also the percentage error of each determination as compared with the mean value, .0940, is small, being less than 1 per cent.

These facts seemed to warrant proceeding with a series of determinations of the specific heat of copper and other metals at low temperatures by the same method, employing liquid oxygen.

Five determinations of the specific heat of copper between the boiling point of liquid oxygen, under atmospheric pressure (-181.4°C.), and 11 C. were as follows:

TABLE 2.

Substance.	Determination Number.	Specific Heat (-181.4°... 11°C.)
Copper.	1	.0867
"	4	.0854
"	7	.0882
"	10	.0873
"	13	.0868
	Mean	.0868

Average variation of the five determinations from the mean, .0007, or .8 per cent.

Greatest variation of any one determination from the mean, .0014, or 1.6 per cent.

Weight of water used in each determination, 70.01 grams.

Weight of copper used in each determination, 63.493 grams.

By these experiments the specific heat of copper between  $-181.4^{\circ}$  and  $11^{\circ}$  C. was found to be .0868.

As previously stated, the specific heat of copper between  $23^{\circ}$  and  $100^{\circ}$  C. was found to be .0940.

The two sets of determinations were made by the same method, the accuracy of manipulation in each being about equal, and the same piece of copper was used for both ranges of temperature.

A comparison of the two values shows the specific heat of copper between  $-181.4^{\circ}$  and  $11^{\circ}$  C. to be 7.6 per cent. less than that found in determinations between  $23^{\circ}$  and  $100^{\circ}$  C.

The specific heat of iron between  $-181.4^{\circ}$  and  $13^{\circ}$  C. and that of aluminium between  $-181.4^{\circ}$  and  $15^{\circ}$  C. were also found.

Five determinations of the specific heat of iron between  $-181.4^{\circ}$  and  $13^{\circ}$  C. were as follows :

TABLE 3.

Substance.	Determination Number.	Specific Heat. ( $-181.4^{\circ}$ ... $13^{\circ}$ C.).
Iron.	3	.0890
"	5	.0883
"	8	.0949
"	11	.0912
"	14	.0939
	Mean	.0914

Average variation of the five determinations from the mean .0025, or 2.4 per cent.

Greatest variation of any one determination from the mean, .0035, or 3.8 per cent.

Weight of water employed in each determination, 70.01 grams.

Weight of iron, 51.93 grams.

Five determinations of the specific heat of aluminium between  $-181.4^{\circ}$  and  $15^{\circ}$  C. were as follows :

TABLE 4.

Substance.	Determination Number.	Specific Heat. ( $-181.4^{\circ}$ ... $15^{\circ}$ C.).
Aluminium.	2	.1814
"	6	.1827
"	9	.1851
"	12	.1815
"	15	.1861
	Mean	.1833

Average variation of the five determinations from the mean, .0018, or 1 per cent.

Greatest variation of any one determination from the mean, .0028, or 1.5 per cent.

Weight of water employed in each determination, 70.01 grams.

Weight of aluminium, 19.86 grams.

All of these experiments on specific heat, employing liquid oxygen, were performed consecutively, without interruption.

The determinations were made alternately, and with one exception in the order : copper, iron, aluminium.

The 'determination number' in the foregoing tables of the specific heats of the metals between  $181.4^{\circ}$  and about  $13^{\circ}$  C. shows the order followed.

By this arrangement any change in the temperature of the cold liquid used (liquid oxygen), during the time occupied in performing the experiments, would have been indicated in the results obtained. No such indication is apparent.

The assumption made that the liquid employed had already been transformed by ebullition from liquid air to liquid oxygen was, therefore, virtually substantiated.

Liquid oxygen placed in a vessel surrounded by air at ordinary temperatures boils away rapidly; consequently in the foregoing experiments it was contained in a cylindrical copper receptacle, set inside of another about twice the diameter of the first, which also contained liquid oxygen. With this arrangement the oxygen in the inner receptacle can be made to cease boiling.

This simple method of rendering liquid

gases free from ebullition has been employed by Mr. Charles E. Tripler, and was adopted in the present investigation with a slight modification; the liquid oxygen in the inner receptacle being kept always at a higher level than that in the outer, allowed feeble ebullition in the inner vessel and assured the liquid therein being at its boiling point.

The same weight of water to a gram was used in the calorimeter throughout the experiments of both the specific heat at low temperatures and those between  $23^{\circ}$  and  $100^{\circ}\text{C}$ ., and also in determining the water equivalent of the calorimeter and thermometer.

It was found necessary to filter the liquid oxygen in which the metals were immersed, in order to free it from the solid matter that was present in the liquid. Unless this precautionary measure had been adopted, some of the frozen masses of carbon dioxide, water and other compounds that are in unfiltered liquid oxygen would have adhered to the metals (as was found by experiment), and would have affected the accuracy of the determinations.

The metallic objects of which the specific heat was determined were cylindrical in form and all about equal in volume. The measurements of each were as follows:

Copper—Length, 5.5 cms.; diameter, 1.2 cms.; weight, 63.493 grams.

Iron—Length, 5.5 cms.; diameter, 1.2 cms.; weight, 51.93 grams.

Aluminium—Length, 5.6 cms.; diameter, 1.2 cms.; weight, 19.86 grams.

These pieces were specially constructed on a lathe, and were made with rounded instead of flat ends, so that the liquid oxygen and boiling water would be less apt to adhere to them when they were lifted from these liquids. A small button was turned on the end of each of the metal pieces in construction, and to this a silk thread was attached for transferring them from the hot

or cold liquids to the water in the calorimeter in the two series of experiments. It was considered inadvisable to bore holes in the metal pieces through which to fasten the threads, because drops of the liquids would have been caught in such recesses.

In all of the above experiments with liquid oxygen, before the metals were transferred from the liquid oxygen to the water in the calorimeter, the water was heated a few degrees above the room temperature. The amount that it was thus previously raised was approximately equal to half the number of degrees that the water would fall in temperature when the cold metal was placed in it.

A value for this fall of temperature was determined by a preliminary experiment.

By this means changes in temperature of the water and calorimeter, due to radiation and conduction of heat, and caused by a difference in temperature existing between them and surrounding bodies, were approximately compensated for.

The method of eliminating errors arising from causes similar to those just under consideration was originated by Rumford.

In calculating the values of the specific heats in the above experiments it was assumed that the temperature of the metals in transference from the liquid oxygen to the water in the calorimeter did not change to an appreciable amount. This assumption was apparently substantiated by the following experiments:

The metals were lifted out of the liquid oxygen, and again immersed after a period of two seconds. It was noted that no boiling whatever could be observed as they were replaced in the liquid. In ten observations made with a watch provided with stop attachment, in which the time that the metals were held out of the liquid air varied from  $1\frac{3}{5}$  sec. to  $2\frac{1}{5}$  sec., no boiling was perceived when they were replaced in the liquid.



With an extension of the time that the metals were held out of the liquid to three seconds, a slight effect of boiling was apparent when they were replaced.

In the determinations of specific heats for low temperatures it required only one second or less to transfer the metals from the liquid oxygen to the water in the calorimeter. It, therefore, seems probable that little heat was absorbed by the substances during the time required for their transference from the liquid oxygen to the calorimeter. In the experiments with liquid oxygen transference of the metallic objects from the cold liquid to the water in the calorimeter was accomplished with less difficulty than the transference of the same objects from boiling water to the water in the calorimeter, as performed in the preliminary experiments on the specific heat of copper between 23° and 100° C.

Little or no liquid oxygen was carried over to the calorimeter on the metal pieces, it having boiled off before they were placed in the water; therefore a correction similar to that applied in the experiments with boiling water was not necessary.

The value of the specific heat of iron between -181.4° and 13°, C., as determined by the foregoing experiments, is .0914.

The lowest value for the range, 15°...100° C., according to recorded results, appears to be about .113 (.1130, 0°...100° C., Tomlinson).

The value for the specific heat of iron between -181.4° and 13° is, therefore, approximately 19 per cent. less than the lowest value for the range, 15°...100° C.

The specific heat of aluminium for the low temperature range was found to be .1833.

The lowest value for the range 15°...100° C. seems to be about .212 (15°...97° C., Regnault).

The value for the specific heat of this metal between -181.4° and 15° C. is 13.6

per cent. less than the lowest value for the range 15°...100° (97°) C.

The values for the specific heat for the ranges, 0°...100° C. and 15°...97° C. given, were taken from *Physikalisch-chemische Tabellen*, by Landolt and Börnstein, 1894 Ed.

The variation in the values, as given by different authors, of the specific heat of certain metals for the range 15°...100° C. is no doubt partly due to the employment of metals of different degrees of purity. For this reason the specific heat of the pieces of iron and aluminium used in the experiments with liquid oxygen have been determined between 23° and 100° C. in the manner that the specific heat of the copper for the same range was found.

The determinations were as follows :

TABLE 5.

Substance.	Determination Number.	Specific Heat. (23°...100° C.)
Iron.	16	.1175
"	17	.1151
"	18	.1185
"	19	.1164
"	20	.1136
	Mean	.1162

The weight of water and other quantities were the same in these experiments as those with copper (23°...100°C.).

The determinations of the specific heat of aluminium between 23°...100° C. were as follows :

TABLE 6.

Substance.	Determination Number.	Specific Heat. (23°...100° C.)
Aluminium.	21	.2190
"	22	.2165
"	23	.2225
"	24	.2128
"	25	.2158
	Mean	.2173

The accuracy of manipulation in these two sets of determinations was about equal to that of the experiments on copper for the same range of temperature.



If the results of the determinations just given and those for copper for the same range, 23°...100° C., are employed, a comparison can be made between the specific heat of pieces of certain metals (copper, iron, and aluminum) determined between —181.4° C. and 13° C. and the specific heat of the same pieces of metal determined between 23° and 100° C., by the same method.

The following table has been arranged to show this comparison :

TABLE 7.

Metal.	Specific Heat. —181.4°...13° C., (employing liquid oxygen).	Specific Heat. 23°...100° C., (employing boil- ing water).	Actual difference between two values.	Percentage differ- ence between two values.
Copper.	.0868	.0940	.0072	7.6 %
Iron.	.0914	.1162	.0248	21.3 %
Aluminium.	.1833	.2173	.0340	15.7 %

It is shown by this table that the specific heat of copper, iron and aluminium between —181.4° C. and about 13° C. were found to be, respectively, .0868, .0914 and .1833, or 7.6, 21.3 and 15.7 per cent. less than the specific heat of these metals determined between 23° and 100° C.

An error of several degrees in the low temperature value (—181.4° C.) would affect the accuracy of these results only to a small amount. If, for example, the specific heat of iron for the low range of temperature is assumed to be the same as between 23° and 100° C. it would mean that an error of over 40 degrees had been made, which is obviously impossible. If there are errors in the results given above, the present indications are that they are less than one per cent.

The value of the water equivalent of the calorimeter and thermometer finally used in the calculations in all the specific heat experiments was obtained from the mean of

ten determinations. The mean value was 5.87 grams.

The calorimeter was made of copper, cylindrical in form ; height, 9.75 cms.; diameter, 4.0 cms.; and weight, 35.498 grams.

The thermometer was one made by Henry J. Green, No. 8407, graduated to  $\frac{1}{2}^{\circ}$  of a degree Centigrade, and could be read to  $\frac{1}{100}^{\circ}$  of a degree.

C. C. TROWBRIDGE.

COLUMBIA UNIVERSITY, June 16, 1898.

#### THE FLICKER PHOTOMETER.

PROFESSOR ROOD'S interesting article in SCIENCE of June 3d prompts me to add a few words corroborating his statement as to the ease with which the flicker photometer is handled by observers unaccustomed to its use. If the lights to be compared differ at all in color, it is probably more easy to use, for the unskilled observer, than ordinary photometers, as the following experience, among others, shows. While I was experimenting, in 1895, with the revolving disk instrument to which Professor Rood refers, two chemists, in the course of an investigation, found it necessary to compare photometrically the illuminating powers of several different specimens of refined petroleum. I placed at their disposal a Lummer-Brodhun and a Bunsen Photometer, and showed them, as a matter of interest, the newly-devised flicker instrument. The standard lamp differed slightly in color from the flames given by the oils under investigation, so that the two observers found it somewhat difficult to obtain concordant results with either of the two ordinary photometers. They, therefore, reverted to the flicker instrument, using it to check all their results, finding its use, under the conditions, more agreeable and certain than either of the others.

With the Lummer-Brodhun or the Bunsen instrument they experienced all that unpleasant sensation of uncertainty which

attends the comparison of differently colored lights; each found it hard to make readings agreeing with the other, or even to verify the other's readings. With the flicker instrument these difficulties disappeared.

As Professor Rood says, there is little or no more difficulty or fatigue in the use of this instrument than in other optical observations, the approximate setting being quickly made, and the flicker near that point being so slight as not to disturb the eye, yet being distinct enough to require no especially strained attention, unless the illumination is too feeble. I may call attention here once more to the statement in my previous paper, that the method used by Professor Rood, of keeping the photometer and one lamp stationary, moving the other, has certain notable advantages in the use of this instrument, especially in the comparison of a number of lights differing greatly in color and in brightness, in that the standard light can be kept at a fixed distance from the photometer, and all the measurements made at the same absolute brightness, insuring about the same quality of flicker, and about the same degree of sensitiveness throughout.

The arrangement, however, is obviously not so sensitive as that in which both lights are stationary and the photometer itself is moved, and probably the latter method is generally preferable when the lights are sufficiently bright. It takes a little longer to make a setting with the flicker photometer than with others, and for this reason it is not easy to use upon an arc light, where the brightness is continually changing. This difficulty, of course, varies greatly with the character of the arc.

The essence of the flicker photometer lies in this, that the two fields to be compared are presented to the eye alternately, in rapid succession, and not as in other instruments simultaneously, and side by side. There is no attempt to compare the two

lights. One simply notes the disappearance of a certain recurrent sensation. It is evidently necessary that the two fields compared should fill exactly the same portion of the whole visual field, and it is desirable that the time taken in transition from one field to the other should be as small a portion as possible of the whole time of observation, in order that the retinal shock, to which the 'flicker' sensation is due, may be sharp and sudden. I am inclined to think that the latter condition is more easily and completely met by a rotating than by an oscillating apparatus.

Professor Rood's form of the instrument possesses some advantages over the rotating disk. The faces of the large prism are rigid, and the same portion of each of them is always used. A rotating disc is thin, easily bent or distorted, and there is a possibility of difference in the character of the surface of different parts, which, since the whole of it passes in review before the eye, might cause a flicker between different portions of the disk itself. A flat disc of zinc, however, to which is firmly glued a sheet of white paper, gives but little trouble, and the line separating the two fields is rendered almost imperceptible by filing thin that edge of the disk which passes in front of the eyepiece. Again, the method of construction of the disk photometer makes it impossible that the two lights to be compared should be in the same line parallel to the photometer bar, an arrangement which becomes inconvenient if it is desired to change from this to another photometric apparatus. This difficulty is avoided in the oscillatory apparatus of Professor Rood.

I may mention here a form of the flicker photometer (described at the Detroit meeting of the American Association for the Advancement of Science, but not elsewhere published) which avoids some of the difficulties of the disk form and is more convenient for ordinary photometric purposes.

A short truncated cone is made of wood, and the conical surface carefully whitened. The approximate dimensions of the cone in my apparatus are: lower base, 20 cm.; upper base, 15 cm.; height, 3.7 cm. The cone is cut in two along the axis, one-half reversed in direction, and the halves fastened together in this new position. The whole is then mounted so as to rotate about the axis of the cone, which is placed parallel to the photometer bar.

The figure represents the photometer. L and L' are the lights to be compared.

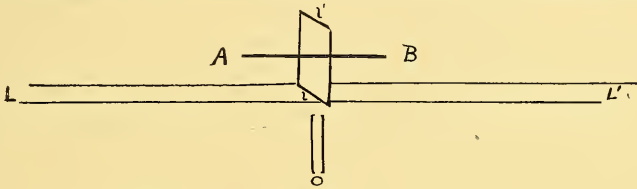

FIG. 1.

The cone, cut and reversed as described, revolves about the axis AB. The plane of division of the cone, as the figure is drawn, passes through this axis and is perpendicular to the paper. O is the eye-tube. When the instrument is in the position shown,  $l$  is in the field of view and is illuminated by the lamp L, but when the cone has made one-half a revolution  $l'$  is seen, which is lighted by the lamp L'.

While this instrument is compact and convenient for most photometric measurements, the disk form is superior for the comparison of pigments, as one of the fields consists simply of a card, which can be removed in an instant and replaced by another. Thus differently tinted papers can be easily compared in succession with the revolving disk, which may be of any color, but which in practice is generally white or gray.

I do not know whether it has been generally remarked that Captain Abney, in his

careful measurements of the distribution of brightness in the spectrum, seems to have used a method of observation closely akin to the flicker method, though apparently without perceiving its definite character or possibilities. His well-known color-patch apparatus places side by side two differently colored fields, the brightness of one of which can be rapidly varied by opening or closing the apertures in revolving sectors. I quote the following from his Tyndall lectures, delivered in 1894:

“By gradually diminishing the range of

the ‘too open’ to ‘too close’ apertures we arrive at the aperture where the two colors appear equally bright. *The two patches will cease to wink at the operator*, if we may use such an unscientific expression, when equality in brightness is established. This operation of equalizing luminosities must be carried out quickly and without concentrated thought, etc.”

It seems probable that Abney, throughout these measurements, applied himself not so much to a careful comparison of the brightness of the two colors involved as to reducing to its faintest condition this *wink*, which differs little in its nature from a flicker.

FRANK P. WHITMAN.

#### BIOLOGICAL SURVEY OF LAKE ERIE.

ON July 1, 1898, the U. S. Commission of Fish and Fisheries will inaugurate a biological survey of Lake Erie, under the direction of Professor Jacob Reighard, of the

University of Michigan. Commissioner Bowers has allotted a liberal sum for the first season's inquiries, and will undoubtedly provide for a continuance of the work over several years. Professor Reighard will have associated with him Dr. H. B. Ward, of the University of Nebraska; Dr. H. S. Jennings, of the Montana College of Agriculture and Mechanical Arts; Dr. Julia Snow, of Ann Arbor; Mr. A. J. Pieters, of the U. S. Department of Agriculture, and a number of other assistants.

An elaborate plan for the study of the lake fauna and flora has been outlined and will be followed as closely as the circumstances permit. The work will extend over the entire year. Experimental work, similar to that conducted at agricultural experiment stations, will be a prominent feature of the survey, some of the problems to be considered being the rate of growth of fishes; the food of young fishes reared from the egg and the changes in their regimen during growth; the source of food of aquatic rooted plants; the life histories of food fishes reared in aquaria or ponds, and of certain aquatic insects and other invertebrates; the rate of increase of the plankton as a whole and of its individual constituents. There will also be systematic studies of the habits, migrations, distribution and food of the fishes and other organisms of the lake.

At the beginning of the work Professor Reighard and Dr. Ward will devote a considerable amount of time to plankton problems, especially the perfection of methods and apparatus; Dr. Snow will carry on experimental work on the algæ; Dr. Jennings will undertake experimental researches on the protozoa, and Mr. Pieters will pursue studies of the aquatic flora. The summer headquarters of the survey will be at the government hatching station at Put-in-Bay, South Bass Island, Ohio.

Lake Erie affords an excellent field for

work of this character, on account of its varied fauna, diversified physical features, extensive fishing interests, and the recent serious depletion of the supply of certain valuable food fishes. The investigations may ultimately be extended to some of the other Great Lakes.

H. M. SMITH.

U. S. COMMISSION OF  
FISH AND FISHERIES.

#### EUGÈNE FLACHAT.

THE committee on the inauguration of the monument erected to the memory of Eugène Flachet, of the *Société des Ingénieurs Civils de France*, issued invitations to scientific and professional colleagues on both sides of the Atlantic. The ceremony took place June 12th, at Paris, at the intersection of the streets named for Brémontier, Alphonse de Neuville and Eugène Flachet. We glean the following from the circular issued by the committee:

Flachat, one of the most famous, and justly so, of French engineers, was the designer of the now familiar I-section of rolled iron or steel beam, universally employed in construction.

Flachat was born in 1802. He exhibited his genius for construction, and his inclination toward engineering as a profession, in earliest childhood. As a school boy he was called upon to check the mathematical work of his master, and as a youth investigated the proportions of parts of structures and machinery with the greatest completeness and success. He became particularly interested in metallurgy, constructed the largest blast furnaces and mills of the Ardennes, organized the forges at Commentry and, with Barrault and Petiet, produced a great work, now classic, on the metallurgy of iron which is known by their names. He wrote many articles and brochures, some on economics and related subjects. His main occupation was the construction of railways; but he published descriptions of



a great variety of other works, illustrating his versatility, his industry and his extensive interests. Inaugurating in France the era of railways, he also, as a sequence and as a part of that great work, had a hand in the perfection of their bridges and stations and locomotives and other rolling stock, and in all forms of related constructions, whether architectural or mechanical. He it was who, perhaps more than any other, created the systems of construction, organization and operation of the French railways. In 1848 he was called upon to rebuild the old wooden bridge at Asnieres, and showed his originality and boldness by reconstructing it in wrought iron, and, further, in rebuilding it and transferring traffic to it from the temporary construction improvised upon the burning down of the old bridge, without the delay of a single regular train. From that time the substitution of iron as a building material for wood, in his work, was a fruitful source of fame. He performed the, as then thought, most marvellous feats and always with success; for his computations were always accurate and based upon data ascertained by his own experiments and observations to be safe and correct. The framing of exposition buildings, in 1878 and in 1889, by Dion, his favorite disciple, and by Contamin, his follower, were illustrations of the methods of Flachet.

Flachet reconstructed the foundations of the cathedral of Bayeux, saved its central tower from imminent danger of falling, and restored the church, without accident or delay, and this after the experts consulted had declared the case beyond remedy. He there used a now common form of support, hollow iron columns, of large diameter, filled with concrete, as substitutes for the failing foundations.

The memorial erected in Paris is placed by his now few surviving pupils, aided by many friends and numerous admirers, as a

testimonial of their appreciation of the service rendered by the great engineer to his country.  
R. H. T.

#### CURRENT NOTES ON METEOROLOGY.

##### MOHN'S GRUNDZÜGE DER METEOROLOGIE.

MOHN'S *Grundzüge der Meteorologie* has long been one of the favorite text-books of meteorology in Europe. Its author is well known as professor of meteorology at the University of Christiania and Director of the Norwegian Meteorological Institute. The book was first published in Norwegian, and was translated into German by the author himself, the last German edition (the 4th) bearing the date 1887. We now have a new German edition, the fifth (Berlin, Reimer, 1898), enlarged from 364 to 419 pages, and with several changes. Among the additions we note a description and a cut of the Assmann aspiration psychrometer and of the Richard thermograph. There is a new chart of mean annual ranges of temperature, and the other temperature charts are revised. Mention is made of so recent a phenomenon as the Paris *trombe* of September 10, 1896. The general arrangement of the book is the same as in the former edition, and there is, unfortunately, the same lack of an index.

##### VAN BEBBER'S WETTERVORHERSAGE.

THE present year brings us also a new edition, the second, of Van Bebbber's *Wettervorhersage* (Stuttgart, Enke, 1898), the first edition being dated 1891. The book is now some forty pages longer than when it was first written, and a new chapter on weather forecasting for several days in advance has been added. The substance of this chapter was contained in a pamphlet by the author, published in 1896, under the title *Die Beurtheilung des Wetters auf mehrere Tage voraus*. The plan of the work is, in brief, to present by means of a large number of weather charts (over two hundred), arranged

systematic order, the common weather types and the succeeding changes which occur over Europe. After finding in the book a weather map which represents exactly or nearly the same conditions as prevail on any particular day, one can form a judgment as to the kind of weather that will probably obtain on the next day or two, by noting what weather changes took place under similar conditions before. In the chapter on forecasts for some days in advance, Van Bebber defines five common and easily recognized weather types, dependent upon the distribution of atmospheric pressure over Europe. The weather conditions which distinguish these five types may last for various lengths of time, according to circumstances, but they may often be counted on for three days and a half. When, therefore, one of these types is recognized as occurring, a fairly reliable forecast for three days ahead can frequently be made.

#### THE CLIMATE OF CUBA.

BULLETIN No. 22 of the Weather Bureau, entitled *Climate of Cuba; also a Note on the Weather of Manila*, by W. F. R. Phillips, has evidently, as is stated in the pamphlet, 'been somewhat hastily prepared.' The Havana Observatory has given us most of what is definitely known about Cuban meteorology, in its series of annual volumes of observations. Apart from these, there are only fragmentary data. In the present bulletin reference is made to meteorological observations at Key West, Nassau, Port au Prince, San Juan, Porto Rico, and other neighboring places, in order to throw further light on the climatic conditions of Cuba. At Havana the mean annual temperature is 77° F., in round numbers. July has a mean of 82.4°; January has 70.3°. Santiago apparently has a higher mean annual temperature, viz., about 80°. From very fragmentary, and probably also rather

unreliable, records made at Ubajay and the San Fernando mines, in the interior, the mean annual temperature appears to be considerably lower there than on the coast. The relative humidity is fairly constant at Havana, the average being 75%. The mean annual rainfall at Havana is 51.73 inches (based on records for 30 years). The rainy season begins late in May or early in June, and ends in October. 68% of the annual rainfall comes during these months, but in 30 years it has happened five times that the rainfall in the so-called dry season has equalled or exceeded that of the rainy season. The northeast trades are the prevailing winds, but these are occasionally interfered with by cyclonic winds. In winter, *northers* are felt along the northern coast of Cuba, these being due to the passage of cyclonic centers over the southern portion of the United States.

A few paragraphs at the end of the report, concerning the *Weather of Manila*, were compiled by Professor H. A. Hazen. The data relate to the observations made at the Manila Observatory. The mean annual temperature at Manila is 80° F. May, the hottest month, has 84°, and December and January, the coldest months, have 77°. September has 85% of relative humidity, and April, 70%. The mean annual rainfall is 75.43 inches, of which 50.74 inches fall in June–October. It is to be regretted that this bulletin was not made more complete, as the information it gives, especially concerning Manila, is very fragmentary indeed.

R. DEC. WARD.

HARVARD UNIVERSITY.

#### CURRENT NOTES ON ANTHROPOLOGY.

##### THE BUILDING SACRIFICE.

On all continents and in all ages when an important building is commenced or finished some kind of celebration takes place. Very generally it used to be a sacrifice, human, or of some lower animal. This

custom is the theme of a thorough study by Dr. Paul Sartori in the *Zeitschrift für Ethnologie*, Heft I., 1898.

Having demonstrated its wide extension he seeks for the psychical motives which prompt it. They are complex. Sometimes the offering was to the spirit of the place or to the gods for the undertaking; or it was to obtain a guardian divinity in the soul of the victim; or it was magical, by the spilling of blood to drive away evil spirits; or it was a procedure in sympathetic magic, the offering or victim being eaten with joy, so that joy should abide in the house; or the sacrifice was in some way vicarious, a substitute for what fate might otherwise demand of the house owner.

The article is a good example of exposition and analysis applied to a widespread rite.

#### THE CUSTOM OF 'DHARNA.'

The legal practice in India of *Dharna*, or sitting at a debtor's door and not eating until the debt is paid, still obtains in that country and is as old as the laws of Manu. The debtor must either pay up or move away, or else the creditor will starve himself to death. This would seem to us a very silly proceeding on the part of the creditor; but Dr. S. R. Steinmetz, in a study of the custom printed in the *Rivista Sociologia Italiana* for January of this year, points out that when the meaning and origin of the usage are appreciated, it is by no means so foolish as it looks. Should the creditor die from hunger, the debtor is held responsible for murder, and the terrible penalties of blood revenge will be wreaked upon him by the family of the creditor. Not only the debtor himself, but all his kin or gens will become the targets of a merciless vendetta. With this certainty in view, any sacrifice on his part would be wiser than to allow the creditor to perish.

D. G. BRINTON.

UNIVERSITY OF PENNSYLVANIA.

#### SCIENTIFIC NOTES AND NEWS.

##### THE MEETING OF THE AMERICAN ASSOCIATION.

A PROPOSITION to invite the American Association for the Advancement of Science to meet in Philadelphia in 1899 was referred by the Council of the Academy of Natural Sciences for consideration to a committee consisting of Messrs. Samuel G. Dixon, Thomas Meehan, Rev. Henry C. McCook, William Powell Wilson, Henry Skinner and Edward J. Nolan. After consultation with representatives of other scientific institutions and educational interests at a well attended meeting held in the Academy on the 22d inst., the following was unanimously adopted:

As the first meeting of the American Association for the Advancement of Science was held in Philadelphia in 1848, and as it is fourteen years since the most successful meeting in its history was also held here,

*Resolved*, That this meeting, in the belief that the second half century of the Association's career should begin in the city of its birth, approve of the suggestion that an invitation to meet in Philadelphia in 1899 be conveyed to the session to be held in Boston next August.

After a statement by Dr. Nolan regarding the successful methods of the local committee in 1884, and remarks in support of the proposition from Dr. Daniel G. Brinton, those in attendance signed a form of invitation to be transmitted to the Association in time to be acted on by the Boston session, and the Secretary was directed to obtain the signatures of representatives of the municipal government and others endorsing the movement but unable to be present.

The brilliant success of the meeting of 1884, and the desirability of starting the Association on its second half century under the most favorable auspices, after what will undoubtedly be a largely attended session in Boston, are sufficient reasons for the movement thus inaugurated. It is especially fitting that the preliminary steps should have been taken by the Academy of Natural Sciences, not only because of the honorable position it has always maintained in the scientific world, but also because the first meeting in 1848 was held within its walls. If the invitation to meet next year in Philadelphia be



accepted by the Association a satisfactory combination of scientific and social interest may be confidently anticipated.

AWARD OF THE LOUBAT PRIZES.\*

The undersigned, a committee appointed in 1895 to examine and report upon the various monographs submitted in competition for the Loubat prizes to be awarded in 1898, beg leave to report that they have carefully considered the different works received, and have also, in accordance with the rules governing the competition, examined such other works relating to American archæology as have been published in the English language during the three years ending with the first day of April, 1898. In their consideration of these monographs the Committee have taken into account not only the scientific value of the work, but also the importance of the subjects treated, the methods of investigation pursued by the authors, and the artistic and literary excellence of the presentation.

The monographs that were formally submitted for examination were the productions of eight different authors. Of these the committee have selected as being the most meritorious, and as most fully complying with the conditions prescribed for the competition, the treatise offered by Mr. William Henry Holmes, Curator of the Department of Anthropology in the National Museum at Washington. The title of this treatise is 'Stone Implements of the Potomac-Chesapeake Tide-Water Provinces.'

This volume may be held to mark an epoch in American archæological research, by interpreting the remarkably abundant artifacts of a typical region in the light of previous studies of actual aboriginal handiwork, and thus establishing a basis for the classification of the stone art of the entire western hemisphere. It is the result of many years of personal study, numerous experiments and close typographical analysis, and is supplied with a wealth of illustrative material that gives it most exceptional interest and value. The Committee, therefore, recommend that the first prize of \$1,000 be awarded to Mr. William Henry Holmes.

\*Report of the Committee to President Low, of Columbia University.

The elaborate monograph entitled *The Social Organization and Secret Societies of the Kwakiutl Indians*, by Dr. Franz Boas, of the Metropolitan Museum of Natural History of New York City, is a remarkably complete descriptive and analytic treatise setting forth the characteristics of a well studied tribe in such a manner as to offer a model for students and raise the standards of ethnological work. Its information is derived from personal research conducted on the very best scientific principles and dealing with a wealth of carefully collected material. Your Committee, therefore, recommend that the second prize of \$400 be awarded to Dr. Franz Boas.

Of the remaining authors represented in the competition the Committee desire to single out for especial mention Dr. Karl Lumholtz, who presented a treatise entitled *Objective Symbolism of the Huichol Indians*; Mr. Frank H. Cushing, who offered a manuscript interpretive of aboriginal art and industry under the title *Tomahawk and Calumet, Shield and Gorget*; and Dr. Walter Hoffman, whose extended memoir embodies a careful study of the Menomoni Indians.

The Committee desire also to mention with especial commendation a work by Alfred P. Maudslay, of London, dealing with the archæology of Central America. This work was not submitted by its author in the competition, and it has not yet been completed in publication; but its great merit is such as to demand some especial mention on the part of this Committee..

All of which is respectfully submitted.

Committee: H. T. PECK, *Chairman*.

D. G. BRINTON,

W J MCGEE.

MAY 21, 1898.

NEW GASES IN THE ATMOSPHERE.

A FURTHER communication of great interest on the occurrence of hitherto unsuspected elements in the atmosphere was made, according to the *London Times*, to the Royal Society by Professor Ramsay and Mr. Travers, on June 16th. Since the discovery of argon it has always been a question whether the gas isolated by Lord Rayleigh and Professor Ramsay was in reality a single uniform substance, a point which was very difficult to settle owing to the



impossibility of applying any ordinary chemical test. Moreover, as the molecular weight of helium—which shares with argon the peculiarity of being an entirely inert element—is four, whilst that of argon is almost 40, it appeared probable that an element of intermediate molecular weight remained to be discovered. Professor Ramsay and Mr. Travers have, therefore, prepared a large quantity of ‘argon’ from atmospheric nitrogen; separating this latter gas by means of magnesium, and having liquefied it by cooling with liquid air, they have then fractionally distilled the product. The first portion, consisting of less than one hundred cubic centimeters, distilled off from the liquid obtained by condensing 18 litres of argon, was found to have a density of about 13 instead of 20, which is that of argon; and its spectrum differed from that of the known gases, a yellow line, less refrangible than those characteristic of helium and krypton, being especially prominent. On continuing the distillation, after nearly the whole of the liquid argon had evaporated, a solid was obtained which only slowly volatilized. The gas into which this solid was converted was found to be of practically the same density as argon, but its spectrum was altogether different and peculiar, consisting for the most part of bands, not of lines. It is proposed to call the lighter element Neon, and that derived from the solid Metargon.

These observations, as well as those on krypton communicated to the Society the previous week, must obviously be regarded as but indications of the presence in various minute proportions of a variety of new substances, probably all elements, in the atmosphere. Further development of the investigations will be awaited with interest. The success which has thus far been obtained is striking proof of the great value of the new engine of research which liquid air affords, especially as diffusion experiments had failed to afford any evidence of the presence of such substances in our air.

CIVIL SERVICE EXAMINATIONS IN SCIENCE.

THE Civil Service Commission invites attention to the fact that no applications were filed for the examination scheduled to be held on June 7th for Assistant Curator, U. S. National

Museum (Division of Mammals), Smithsonian Institution; and it announces that July 21st has been set for examination for the position mentioned, salary \$1500 per annum. Applicants will not be required to appear before a board of examiners for examination, but they will be rated on the elements of education, experience, publications and a thesis, which are to be indicated upon special forms furnished by the Commission. These subjects will be weighted 10, 15, 50 and 25 per cent., respectively. The Department states that it is desirable that persons certified for this position shall be men not less than 25 nor more than 40 years of age and that they should possess a good general education (college graduates preferred); a general knowledge of zoology and a thorough knowledge of mammalogy, more especially as relating to the North American fauna; they should have a practical knowledge of field collecting, and of museum methods of preserving, arranging and labeling collections.

On July 14th an examination will be held to fill two vacancies in the grade of Assistant, U. S. Coast and Geodetic Survey, Treasury Department, the salaries of which are \$1,200 per annum.

The examination will consist of the subjects mentioned below, which will be weighted as follows:

Knowledge of the operations of geodesy, .	40
Experience in the work of a trigonometric survey, .....	40
Knowledge of field astronomy, .....	20

A statement of the experience in the work of trigonometric survey is to be submitted upon a special form, which will be furnished applicants with their application blanks. This statement must be filed with the application. Applicants for this examination must not be over 50 years of age.

No eligible candidates were secured from the examination held on May 6, 1898, for the position of Chief of Division of Library and Archives, U. S. Coast and Geodetic Survey, Treasury Department, and another examination will be held on July 21st and 22d. The salary of this position is \$1,800 per annum.

The examination will be as follows:

Basis examination (spelling, arithmetic, penmanship, letter-writing, copying from plain copy, copying from rough draft—first grade), .....	15
Library economy, .....	30
Bibliography, .....	30
French and German, .....	15
Experience, .....	10

An examination will be held on July 21st, for the position of Assistant Chief, Division of Forestry, Department of Agriculture, at a salary of \$1,800 per annum.

The examination will be as follows:

Forestry, .....	60
Botany, .....	5
French or German (translation into English of passages relating to forestry), .....	10
English (essay on a forestry subject), .....	5
Experience, .....	20

Another examination in the Division of Forestry will be held on July 28th, to fill the position of District Assistant at a salary of \$1,200 per annum. The examination will consist of the subjects mentioned below, which will be weighted as follows:

Forestry, .....	60
Botany, .....	5
English (essay on a forestry subject), .....	5
Experience, .....	30

#### GENERAL.

IN connection with the Congresses of Physiology and of Zoology, to be held in Cambridge next August, it is proposed to confer the honorary degree of Doctor of Science on Professor Bowditch, of Harvard; Dr. Anton Dohrn, of Naples; M. A. Milne Edwards, of Paris; Professor Golgi, of Pavia; Professor E. Haeckel, of Jena; Professor Hubrecht, of Utrecht; Professor Kowalevsky, of St. Petersburg; Professor Kronecker, of Berne; Professor Kühne, of Heidelberg, and Professor Marey, of Paris.

PROFESSOR K. VON RÖNTGEN, of Würzburg, has been awarded the Elliot-Cresson medal of the Franklin Institute of Philadelphia.

DR. H. MOLISCH, professor of plant physiology of the German University of Prague, has returned after a trip around the earth for purposes of research, having made special studies in Java.

DR. J. HANN, professor of meteorology in the

University of Gratz, has been made honorary member of the Geographical Society of Lima, Peru.

DR. SIMON SCHWENDENER, professor of botany in Berlin, has been made a knight of the order *pour le mérite* in science and art.

THE freedom of the city of Edinburgh was conferred on Lord Lister on June 15th.

WE regret to record the death, on June 28th, at Munich, of Dr. George Bauer, associate professor of paleontology in the University of Chicago.

DR. THEODOR EIMER, the eminent zoologist, professor in the University of Tübingen, died on May 30th, aged 30 years.

THE death is also announced of M. Souillard, professor of astronomy in the University of Lille, and a corresponding member of the Paris Academy of Sciences.

MR. C. W. A. HERMANN, a mineralogist, died in New York on June 21st, at the age of 97 years.

AFTER all public works in New York City had been stopped, under the new city administration, we are glad to learn that the Board of Estimates and Apportionment has authorized the reissue of \$375,000 in bonds for the construction of buildings for the Botanical Garden in Bronx Park. Work on the Museum Building is being carried forward, the contract calling for its completion early next year.

IN addition to the comet discovered photographically by Mr. E. Coddington, of the Lick Observatory, and observed on June 11th, the light of which is said to be equal to that of a star of the magnitude of 7.7, Professor Perrine, of the Lick Observatory, discovered a faint comet on June 14th, and Mr. Hussey discovered Wolf's periodical comet on June 16th. The positions have been telegraphed by Professor Keeler, Director of the Lick Observatory, and are published in a special circular of Mr. Ritchie's Science Observer, issued on June 20th.

THERE is nothing in America corresponding to the civil list pension in Great Britain. There have been given during the past three years twenty-seven pensions under the British government, of which the following were in re-

cognition of scientific work: Mrs. Henrietta Anne Huxley, widow of Right Honorable Professor Thomas H. Huxley, scientist, £200. Dr. John Thomas, Arlidge, hygienist, £150. James Hammond, mathematician, 120. Oliver Heavyside, electrician, 120. Miss Anne Walbank Buckland, anthropologist, 80. Mrs. Fanny Hind, widow of Dr. John R. Hind, F.R.S., astronomer, 70. Mrs. Margaret Anne Houghton, widow of Rev. William Houghton, scientific writer, 50. Samuel Alfred Varley, electrician, additional, 50. Aug. Henry Keane, F.R.G.S., ethnologist, 50. Misses Frances Elizabeth, Mary and Julia Dobson, sisters of the late Surgeon-Major George E. Dobson, F.R.S., zoologist, each 25.

SURGEON-GENERAL STERNBERG has written as follows to the *Army and Navy Journal* regarding the danger of yellow fever in Cuba: "In your issue of April 23d, page 642, the statement is made that General Sternberg 'expresses confidence in the excellent sanitary provisions of the military service, and does not fear that yellow fever will prove more harmful to the troops than diseases which are common in the Northern latitudes,' etc. I have not expressed any such optimistic opinion, and regret to say that it is not justified either by my studies relating to yellow fever or by my personal experience. History teaches that when a considerable number of unprotected persons are exposed in a yellow-fever-infected locality during the months when this disease is most prevalent (May 1st to November 1st, in the latitude of Havana) an epidemic almost infallibly results. In the last week of April of last year there were 17 deaths and 70 new cases of yellow fever in the city of Havana. Now, suppose that we had a similar number of cases at the same season in New Orleans and that 20,000 strangers from the North should go there to spend the summer, what would be the result? All past experience supports the belief that a majority of them would have yellow fever, and that from 20 to 40 per cent. of those taken sick would die. This is what I anticipate would happen if we should send an army to occupy Havana, or any other infected seaport on the coast of Cuba during the summer months. If, however, these troops could be camped upon high land in the interior,

and circumstances were such as to enable them to comply with all of the exactions of modern sanitary science, I am of the opinion that our loss from yellow fever would not be serious. But in time of war military commanders are expected to take their troops to the points occupied by the enemy, and a picnic in the interior with frequent changes of camp, etc., is perhaps not exactly what we may expect. I am not an alarmist, but I believe in looking facts fairly in the face and cannot allow your statement of my opinion to have currency at such an important moment in our country's history without a protest."

#### UNIVERSITY AND EDUCATIONAL NEWS.

Two of the conditional gifts of \$50,000 offered by Dr. D. K. Pearsons have been secured by the colleges collecting the additional sums required. The endowment of Beloit College is thus increased by \$200,000 and that of Mt. Holyoke College by \$150,000.

The sum of \$50,000 has been given from a source not named to Amherst College for an academic hall, to be built in honor of President Seelye. The class of '95 of Amherst has collected \$24,000, with which a laboratory building will be erected.

The University of Virginia has received \$20,000 from Henry L. Higginson, Treasurer of the J. W. and Belinda Randall Charities Corporation of Monson, Mass., to be used for the erection of a building or as a permanent fund.

A BENEFACTOR of Edinburgh University, who desires for the present that his name should be withheld, has given the University such a sum as may be necessary, but not exceeding £10,000, to build and equip a laboratory and class-room to be used for the teaching of public health.

DR. MERRILL E. GATES has resigned the presidency of Amherst College.

DR. CHARLES HARRINGTON has been appointed assistant professor of hygiene, and Dr. Franz Pfaff instructor in pharmacology and physiological chemistry, in Harvard University.

ROLLINS A. EMERSON, of the Department of Agriculture, and a graduate of the University of Nebraska, has been elected to the assistant professorship of horticulture in his *alma mater*.



He is to assume the duties of the position in April, 1899.

On the recommendation of the General Board of Studies of Cambridge University a University lectureship in chemical physiology was established without a stipend for the present.

#### DISCUSSION AND CORRESPONDENCE.

##### ON THE EARLY SENSE OF SELF.

TO THE EDITOR OF SCIENCE: Professor G. Stanley Hall, in the last *American Journal of Psychology*, asks (p. 354) some questions on the early sense of self, which we may briefly answer on the basis of evolutionary psychology.

1. "In the first contact of hand and mouth does the latter feel the former first and most, or *vice versa*?" We answer that the mouth feels the hand first and most, because the mouth is the earlier integrated tactual organ in the history of life. The hand as locomotive organ modified for grasping, only gradually becomes tactile in the race and individual. The hand is merely one object of the many which the child brings to the mouth for interpretation, and so it mouths the hand rather than handles the mouth. The child comes by the peculiar plexus of sensations involved to understand its hand as a different kind of object from its rattle, namely, as a self-object, a part of the somatic self.

2. "Does the eye first find the hand because the eye moves, or because the head moves, and does a motor or a sensory process lead?" As head-moving as method of vision direction is earlier integrated than eye-moving, we should expect the infant to employ head-moving first, and most largely for some time; and for the same reason motor process would lead. We should expect (as p. 351 instances) that the child would first have its attention called to its hands, not through sensations therefrom like temperature or muscular, but by a general movement of hands happening to occur in the field of vision. More thorough studies of infants with reference to head-moving and eye-moving ought to be made, and especially to learn at what age its attention may be directed to its fingers by, *e.g.*, merely pinching them.

3. "What social and ethical factors are involved in the child's scolding and punishing

naughty hands?" The social factor, imitation, is evident, and the ethical factor of the responsibility of the hand for its own acts before it is fully incorporated into the somatic self is also evident. The child who says, when reproached and punished for pushing over a vase, 'I did not do it, hand did it,' is not necessarily falsifying, but often telling the exact truth about the instinctive independency of the hand in its impulse to grasp and push. The child has no memory of acting through his hand, and practically did not, and hence properly blames and punishes the hand. Far more than the adult realizes, the hand with the very young acts in grasping, touching, etc., instinctively and independently, and only very gradually comes in action to be a part of the real self. The parent who exclaims to the child: 'naughty hand!' and punishes the hand, only helps to keep apart in the child's mind the hand-self and the real self; whereas the child should be helped to incorporate its organs into its real self as fast as possible. Pedagogically this is a matter of considerable importance.

4. "Have we, so far, instinct, feeling, will, reason, attention, or mere automatism?" The earliest sense of self in child life is, no doubt, instinctive, in that it comes spontaneously at the impulse of a vast heredity. A reference of all things to the self, a constant interpretation of environment as to its action on the self, is implied in the whole struggle of existence, and strengthens till it becomes thoroughly integrated, that is, becomes instinct. It is plain that the self-unconscious, self-forgetful animal would not have the least chance of survival; but a continual alertness for self is the prime requisite, though the self at the first is undoubtedly very indefinite. The child in its earliest, most subjective experiences, wherein is the merest glimmer of object, namely, in the primitive flashes of pain and pleasure, awakes to itself, and its general struggling repeats earliest life. In these subjective experiences the child builds an *ego* long before it constructs a definite somatic self of hands, feet, etc., which, indeed, are not felt as me, but mine. That is, the somatic self is not the primary and real self, but the child learns the several members as standing in a peculiar relation to its own ex-

periences, and makes the members modes of itself. But while the child *learns* its members most animals appear to be instinctively aware of their somatic self in its parts and so to use them from the hour of birth. But only through the piecemeal learning of the somatic self does there come a full and strong sense of self. The man's hand is more really and fully his than is the crab's claw its claw. Self-conscious self-consciousness and all the high egoism comes of learning. However, the child learns itself in hand, foot, etc., by instinctive impulse, just as it learns to walk instinctively; but the learning, of course, implies attention, will, reason and feeling.

HIRAM M. STANLEY.

LAKE FOREST, ILL., June 16, 1898.

#### COLOR VISION.

In regard to the points concerning which Professor Titchener considers that I have not correctly represented what he had to say on color theories in his letter in SCIENCE of June 17th it is so easy for the reader of SCIENCE to form his own opinion, if he is sufficiently interested in the subject to compare that letter with my reply to it, that there is no occasion, fortunately, to prolong the discussion. Since Professor Titchener has given so much attention to optics during the past year as he says he has done, he must plainly be much more familiar with the subject than most of the psychologists have time to be, and I have certainly hit it off very badly in accusing him of ignorance.

C. LADD FRANKLIN.

#### SCIENTIFIC LITERATURE.

*Organographie der Pflanzen, in besondere der Archeogniaten und Samenpflanzen, I. Teil.*  
K. GOEBEL. Jena, G. Fischer. 1898.

This first part of Dr. Goebel's Plant Organography has been awaited with impatience by many botanists who knew that such a work was in process of construction. Now, that the first half of the treatise is off the press, it can already be understood what an important and timely contribution to botanical literature is this latest work by certainly the foremost German plant morphologist, if not absolutely the foremost in the world. In reading through the

attractive pages one is impressed, first of all, by the charming lucidity of the literary style, then by the freshness of the illustrative material, then by the perfect mastery of a wealth of detail and accessory or incidental matter, and finally by the philosophical and unpolemical tone of the whole. Professor Goebel has succeeded in bringing together from his own voluminous researches, and from the byways as well as the highways of botanical literature, a most interesting and suggestive volume. His general point of view is not at all new, for the foundation of organ-evolution is sought in adaptation rather than in the spirit of the recent *Entwicklungsmechanik*. Strong antagonism is manifested to the archaic 'ideal-philosophy' or 'nature philosophy' of Goethe and Herder, which one would think, from the somewhat unnecessary space given to its annihilation, must exist somewhere in the vicinity of Munich. The Goethean concept of the leaf, the stem, the flower, as in some mysterious sense types, or ideal plans, is generally so extinct that there seems scarcely justification for seriously girding at it. Goebel points out, truly enough, that there is no such thing as a leaf rudiment, but only bud-scale rudiments, sporophyll rudiments, cataphyll rudiments, foliage-leaf rudiments, etc. The leaf and the leaf rudiment are pure abstractions. But this does not seem to the reviewer so strong a position upon which to found a theory of metamorphosis as at first it did. It is true, Goebel's doctrine of pure metamorphosis is based upon just this conception of rudiments, and hence the position is important if one wishes to understand his work.

It would seem that one has quite as much right to insist that there are no bud-scale rudiments, but only willow bud-scale rudiments, poplar bud-scale rudiments, walnut bud-scale rudiments, cherry bud-scale rudiments, etc. Thus the bud-scale rudiment becomes, by the same process of reasoning, quite as vague an abstraction as does the leaf rudiment. As a practical proposition, Dr. Goebel's willingness to substitute analogy for homology in the foundations of botanical terminology cannot have much weight, for everywhere it is the phylogenetic test that is regarded as final, and analogies are rightly regarded as of secondary importance in

all taxonomic systems. But terminology must, in general, be of a sort that can be employed in systematic botany as well as in the departments of pure morphology or organography.

The attempt to construct an organography of plants upon adaptational or epigenetic lines must always be fraught with difficulties, some of which the author has not successfully avoided, but in general the work is most illuminating. A particularly useful chapter is that on symmetry, in which, it should be noted, there is included an independent paper by Dr. A. Weisse on the mechanical principle involved in leaf arrangement. The somewhat variant views of Schwendener and Vöchting are given due weight and discussed with much critical acumen. The part of this chapter dealing with the dorsiventral shoot is one of the few really satisfying chapters in botanical literature. Anisophylly, asymmetry and plagiotropy in general are given a most adequate and instructive treatment. Various species of *Selaginella* are reviewed, and the laws of leaf arrangement upon dorsiventral shoots are largely explained from plants of this one genus.

Of all five chapters, however, the third seems to the reviewer, upon the whole, the most original and valuable. Here Dr. Goebel incorporates his own results to a very considerable degree, and gives the first connected and philosophic account, in botanical literature, of seedlings. After his fashion in his earlier work upon plant development, he includes in the same breath discussion of gametophytic and sporophytic structures—a feature very repugnant to the reviewer—but, nevertheless, manages to leave no point untouched by a wealth of allusion and example, so that when the chapter is finished the reader feels that he never understood seedlings before. The spirit of the enquiry is altogether different from the drier and essentially formal tone of Sir John Lubbock's well-known book. It is philosophical, suggestive and inspiring.

Nothing particularly new or strikingly helpful is to be found in the closing chapters of the first part—those on malformations and on correlation—for the positions taken are quite exactly those of Sachs, and differ principally from Sachs, in treatment, by the examples chosen.

In general this work is one which will be

everywhere regarded as well maintaining the transcendent reputation of its author.

CONWAY MACMILLAN.

UNIVERSITY OF MINNESOTA.

*A Course in Experimental Psychology*, Part I.: Sensation and Perception. By PROFESSOR EDMUND C. SANFORD. Boston, D. C. Heath & Co. 1898.

Professor Sanford has achieved a difficult task. A laboratory course may be most carefully planned beforehand, but upon trial it will be found quite inadequate in numberless ways; it is only after repeatedly using the course with successive classes, and most carefully correcting and improving it each time, that there is any reasonable security for the hope that the exercises will work smoothly. This series of elementary experiments is the successful result of many years of development in Professor Sanford's laboratory course at Clark University.

The earlier portion of the book (first published in 1894) covers the dermal senses, the kinæsthetic and static senses, taste, smell, hearing, the eye, light and color. The later portion (just issued) treats of visual perception. Some few of the exercises are rather physiological than psychological, but there is no objection to touching upon related problems; even books on physics are accustomed to discuss briefly the anatomy of the eye and the optical illusions. The experiments begin with qualitative ones of a most elementary character; e.g., "Touch yourself in several places with the same object, and analyze out, as far as you can, the particular quality of the sensation by which you recognize the place touched. This quality of a sensation is known as its 'Local Sign.'" A few pages further the experiments become somewhat more elaborate; still further they require apparatus, and so on. In fact, they are carefully graded to increasing difficulty, without ever becoming too difficult for an elementary class. The suggestions in regard to apparatus are, in general, good, although some improvements might be made here; e.g., it is doubtful if the joint-sense apparatus or the Ellis harmonium is worth the cost; if the large wooden pieces, such as tilt board and rotation table, are worth either the cost or the space, etc. The



steel cylinders referred to on p. 381 are quite accurately tuned by Koenig by a special method. In general, it may be said that one of the most expensive ways of getting pieces of apparatus is to have them constructed by 'any carpenter,' e.g., the time required to explain the construction of the Wheatstone stereoscope to an ordinary carpenter, the inevitable use of unseasoned wood, and the high wages demanded by the American workman, make the result ruinously expensive. Successful apparatus can be furnished at reasonable terms only by a conscientious workman under the supervision of the scientist. Can we not hope that Clark University will again add to its reputation by establishing a special mechanic who can make the material for this course under Professor Sanford's personal supervision? This will aid in the introduction of elementary laboratory work throughout American institutions.

In conclusion, it would be hard to overestimate the labor, care and skill that show themselves in every line of Professor Sanford's book; as an elementary laboratory course it is not only a pioneer—it is at the same time a brilliant success. It is to be hoped that this Part I. will be followed by a Part II., which shall serve as a second-year course of a quantitative character; the subject of Time—which has been, I believe, promised for this part—lends itself readily and elegantly to this method of treatment.

As an episode in the history of science this book marks the introduction into psychological work of the elementary qualitative laboratory method which has, for example, been so successful in chemistry; it also bears some resemblance to elementary courses in physics given in some high, normal and grammar schools. It is, of course, not intended that such laboratory work should form the whole of the psychological instruction; a more general treatise would probably be read at the same time, such as Ladd's *Outlines of Descriptive Psychology*, or Titchener's *Primer of Psychology*, or, possibly, my own *New Psychology*, with the omission of the couple of difficult chapters on statistics and color. This elementary qualitative work should be followed by most carefully planned exercises in elementary psychological measurements; at

Yale such a set of thirty exercises has been designed to teach such elementary concepts and methods as 'average,' 'probable error,' 'function,' 'plotting,' determination of constant errors, compensation of progressive errors, in addition to the usual psychological concepts and observations in touch, hearing, sight, time, etc. This course, in turn, should be followed by advanced work in psychological measurements analogous to that in astronomy, geodesy, etc.; such a course includes a discussion of probabilities, statistics, least squares, etc., and their application to psychological work. With the completion of Professor Sanford's book and the appearance of more advanced laboratory manuals we may hope to find the methods of instruction as well systematized in psychology as in physics or chemistry.

E. W. SCRIPTURE.

---

#### SCIENTIFIC JOURNALS.

*The Journal of Geology* for April-May, 1898 (Vol. VI., No. 3), contains the following papers: 'Chemical and Mineral Relationships in Igneous Rocks,' by Joseph P. Iddings. Professor Iddings continues the interesting discussion of the chemistry of igneous rocks by means of plotted curves, which was begun in a previous number. He first establishes the formulas and molecular ratios of the chief rock-making minerals. Next from a series of diagrams which are plotted by using silica-percentages as abscissas and the ratio of the molecular ratios of alkalis to silica as ordinates for a great number of rock analyses, illustrations and curves of extreme mineralogical composition are drawn. They serve very neatly to localize and group within limits many rock analyses of more complex relationships and cast much light on the minerals that must result in the crystallization of maqueas whose composition is known. 'The Weathered Zone (Yarmouth) between the Illinoian and Kansan Till Sheets,' by Frank Leverett. This weathered zone is most pronounced and best recognized in the region between Davenport, Iowa, and Quincy, Ill. Its character is illustrated by various well-sections. 'The Peorian Soil and the Weathered Zone (Toronto Formation),' by Frank Leverett. A bed of muck and weathered soil, for which the

name 'Peorian' is suggested, lies between the Iowan and the Wisconsin till sheets. It is provisionally correlated with the earlier named Toronto beds of peat, etc. 'A Geological Section Across Southern Indiana, from Hanover to Vincennes,' by John F. Newsome. A very excellent geological section has been prepared and plotted, but in the illustration the scale is so reduced that the sections are practically illegible. One can only make them out with a magnifying glass. The letter-press describes the formations and their relations to the topography. 'Notes on the Ohio Valley in Southern Indiana,' by Arthur C. Veatch. The paper discusses the phenomena of the development of the present drainage in Spencer County, Ind., along the Ohio, and incidentally throws light on the relations of the continent to the sea during the formation of the Lafayette beds. 'The Brown or Yellow Loam of North Mississippi and its relation to the Northern Drift,' by T. O. Mabry. After defining the loam the author discusses its stratigraphic relations to the underlying Lafayette and the Loess or Bluff formation, which is regarded as an equivalent. The origin and age of the Loess-Loam concludes the paper. It is regarded as a flood-plain deposit of glacial débris, more or less worked over by the wind. 'Classification of the Mississippi Series,' by Stuart Weller. The paper is a valuable review of the subdivisions proposed for the Mississippian and indicates the portion of the continent over which each prevailed.

THE *Physical Review* for June, the last number of the sixth volume, publishes as frontispiece a portrait of the late Professor William A. Rogers, of Colby University. It also contains an obituary notice of Professor Rogers and a bibliography of his contributions to science, including 61 titles. Other articles in the number are: 'On the Surface Tension of Liquids under the Influence of Electrostatic Induction,' Samuel J. Barnett; 'On the Fall of Potential at the Surface of a Metal when exposed to the Discharging Action of the X-Rays,' Clement D. Child; 'An Experimental Determination of the Period of Electrical Oscillations,' Arthur Gordon Webster.

*Terrestrial Magnetism* for June, 1898. The

first article, by Professors Elster and Geitel, describes a method for determining the upward or downward direction of vertical electric currents in the atmosphere by means of atmospheric electric observations. These observations serve as a control upon the results obtained from magnetic observations made at the same time. Professor Abbe continues his article on 'The Altitude of the Aurora above the Earth's Surface.' The present installment gives a chronological summary of the results obtained up to date since Dalton's time. Mr. Putnam gives an interesting summary of Professor Eschenhagen's investigations of the magnetic anomalies in the Harz Mountains. Relations with reference to geological structure and with regard to deviations of the plumbline are discussed and cartographically exhibited.

In the next article Professor Eschenhagen discusses the electric arc disturbances felt by magnetic observatories. The Potsdam Magnetic Observatory insists that no electric railways using the earth as a return circuit be allowed within a radius of fifteen kilometers.

Letters to the Editor and reviews conclude the number.

#### SOCIETIES AND ACADEMIES.

##### CHEMICAL SOCIETY OF WASHINGTON.

THE 103d regular meeting of the Society was held on May 12, 1898.

The first paper of the evening was presented by Messrs. F. K. Cameron and H. A. Holly, and was entitled 'Acetone-Chloroform, 1st paper.' Acetone-chloroform is produced by bringing together acetone and chloroform and adding powdered potassium hydroxid to the cooled mixture in small portions at a time, allowing to stand until the reaction is completed and fractionating the fluid products. The experiments which are described by the authors have led them to the following conclusions:

I. The existence of but one acetone-chloroform, a white, crystalline solid, a derivative of tri-methyl-carbinol.

II. The substance is not a simple addition product and cannot be resolved into its original constituents by direct means.

III. The substance forms no definite hydrate.

IV. The temperature of the quadruple point



for solid, two solutions and vapor in the system acetone-chloroform-water, is 75°.2.

V. The melting point is near, but above 97°, and in all probability perfectly anhydrous material has not yet been obtained.

VI. The system acetone-chloroform-water seems to present the remarkable case of a solid solution and two liquid solutions.

The next paper was presented by Messrs. P. Fireman and E. G. Portner, and was entitled 'The action of normal propyl alcohol on phosphonium iodid.'

The authors, having undertaken to fill up some of the most important gaps in our knowledge of individual phosphines, communicated as the first contribution the method by which they prepared tri-n-propyl phosphine and tetra-n-propyl phosphonium iodid, and described the properties of these bodies.

Messrs. F. K. Cameron and E. F. Thayer presented a paper on 'The boiling point curve for benzene-alcohol solutions.'

When a mixture of pure benzene and alcohol containing more than 66.5 per cent. of benzene is partially distilled, it will yield a distillate richer in alcohol. Complete fractional distillation will yield a mixture with a minimum constant boiling point of 66°.7 and containing 66.5 per cent. of benzene and a residue of pure benzene. If the original solution contained less than 66.5 per cent. of benzene it will yield a distillate richer in benzene, and complete fractionation will ultimately yield a distillate of the constant boiling solution and a residue of pure alcohol. Under no circumstances can a complete separation of the two compounds be obtained by any process of distillation.

The last paper of the evening was presented by Mr. F. K. Cameron and was entitled 'The benzoyl-ester of acethydroxamic acid.'

The benzoyl-ester of acethydroxamic acid was obtained by Jones as a product of the reaction between sodium isonitroethane and benzoyl chlorid. If ligroin be added to the mother-liquor obtained by the crystallization of the substance from ether another compound is precipitated, isomeric with the first. The isomer is on standing gradually but completely converted into the first modification. Jones regards it as a probable ester of acethydroxamic

acid, the relative orientations of the molecules being indicated thus :

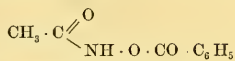

Ester of acethydroxamic acid.

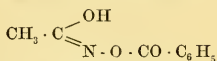

Ester of acethydroxamic acid.

The authors have studied the two modifications, designating, for purposes of convenience, the former as the  $\alpha$ -compound and the latter as the  $\beta$ -compound, and have arrived at the following conclusions :

I. Both modifications exist in the liquid phase.

II. The  $\alpha$ -, or less fusible modification, is the stable one at ordinary temperatures.

III. Crystals of the  $\beta$ -compound can be obtained by dissolving the  $\alpha$ -compound and precipitating the ester suddenly from solution.

IV. The equilibrium concentration changes with the temperature.

V. The  $\alpha$ -compound is converted into the  $\beta$ -compound with absorption of heat.

VI. By raising the temperature of the system and cooling suddenly the point of solidification may be brought below the stable triple point. It was not possible to realize the eutectic point in this manner because of decomposition of the substance.

VII. The eutectic point of the system was shown to be below 66°, and is near 65°.

WILLIAM H. KRUG,  
Secretary.

ACADEMY OF NATURAL SCIENCES OF PHILADELPHIA, JUNE 7.

MR. STEWARDSON BROWN made a communication on plants recently collected by him in the neighborhood of Canogo Lake, Pennsylvania. He described the location and character of the lake, which has an elevation of 2,360 feet, with the finest surroundings of virgin timber in the State. Among other peculiarities of the flora the almost entire absence of blue violets and the profusion and size of *Viola blanda* were noticeable. It was interesting to observe a flora corresponding to our own but with entirely

different species. Illustrative specimens were exhibited.

Attention was called to a collection of exquisite drawings of Australian flowering plants exhibited to the meeting by Mrs. F. C. ROWAN. The Secretary thanked Mrs. Rowan on behalf of the Academy for the opportunity of examining the paintings, which are not only of high artistic value, but of great interest botanically on account of their accuracy of delineation and coloring. The artist has represented upwards of five hundred species, many of which were brought by her for the first time to the knowledge of the late Baron Ferdinand Von Müller, in whose collection specimens of all the plants represented were placed. The work was performed under unusually favorable circumstances by Mrs. Rowan, who cruised among the Australasian islands in a small steamer chartered for the purpose, the result being a collection of drawings of altogether extraordinary beauty and botanical interest as representing probably the most gorgeous flora in the world. Mrs. Rowan is now preparing similar illustrations of American plants. While the material at her disposal is not so striking, the results will, without doubt, be equally artistic.

PROFESSOR HENRY PILSBRY spoke of the scientific work of the late Professors Jules Marcou and Fridolin Sandberger, correspondents of the Academy, whose deaths were announced at the meeting.

At the meeting on June 14th the Entomological Section having precedence, DR. HENRY SKINNER made a communication on a collection of lepidoptera and other orders of insects, illustrating variations in size, peculiarities of coloring and habits, structure, sexual diversity, protective mimicry, etc. Other illustrations were shown by means of lantern and screen.

MR. PHILIP P. CALVERT spoke of mimicry and its relation to so-called natural selection. The two kinds of mimicry, known as Batesian and Mullerian, were defined.

PROFESSOR H. A. PILSBRY called attention to a collection of land shells from the arid region of central Australia. Their distribution resembles that of species from an island-dotted sea,

the desert land being supplied with fugitive lakes in the surroundings of which the species are found. They are mostly ground species and their distribution is not affected appreciably by birds. They are probably survivors of a less arid time.

PROFESSOR CARTER described a method of his own for the destruction of the round-headed apple-tree borer. He sprays the burrows with carbon bisulphide by means of a common atomizer and then covers the openings with soft clay. While the grubs are in every case destroyed, the trees are not affected.

Papers under the following titles were presented for publication:

'List of fishes collected at the Canary Islands by Mr. O. F. Cook, with descriptions of four new species,' by David Starr Jordan and James Alexander Gunn, Jr.

'*Hyalodendron navalium*, a new genus and species of Euplectillid sponge,' by J. Percy Moore.

The type of the genus and species described in the latter paper is one of a small collection of silicious sponges gathered in Japan in 1893, by Mr. Frederick Stearns, of Detroit, and sent to the Academy for determination. They were collected by native fishermen and brought into Yokohama harbor by the dredge boats. The single specimen of *Hyalodendron* is the only one which has been reported. The specimens are accompanied by a set of sketches by a native artist.

EDW. J. NOLAN,  
Secretary.

#### NEW BOOKS.

*A Laboratory Guide in Qualitative Chemical Analysis.* H. L. WELLS. New York, John Wiley & Sons; London, Chapman & Hall, Ltd. 1898. Pp. vii + 189.

*A Short Course in Inorganic Qualitative Analysis for Engineering Students.* J. S. C. WELLS. New York, John Wiley & Sons; London, Chapman & Hall. 1898. Pp. vi + 293.

*Technical Mycology.* FRANZ LAFAR. London, Chas. Griffin & Co.; Philadelphia, Pa., Lip-pincott. 1898. Vol. I. Pp. xviii + 405.

*The Art of Taxidermy.* JOHN ROWLEY. New York, D. Appleton. 1898. Pp. xi + 244.

# SCIENCE

EDITORIAL COMMITTEE: S. NEWCOMB, Mathematics; R. S. WOODWARD, Mechanics; E. C. PICKERING, Astronomy; T. C. MENDENHALL, Physics; R. H. THURSTON, Engineering; IRA REMSEN, Chemistry; J. LE CONTE, Geology; W. M. DAVIS, Physiography; O. C. MARSH, Paleontology; W. K. BROOKS, C. HART MERRIAM, Zoology; S. H. SCUDDER, Entomology; C. E. BESSEY, N. L. BRITTON, Botany; HENRY F. OSBOEN, General Biology; C. S. MINOT, Embryology, Histology; H. P. BOWDITCH, Physiology; J. S. BILLINGS, Hygiene; J. MCKEEN CATTELL, Psychology; DANIEL G. BRINTON, J. W. POWELL, Anthropology.

FRIDAY, JULY 8, 1898.

NATURAL HISTORY MUSEUMS (I).\*

## CONTENTS:

<i>Natural History Museums (I)</i> : L. P. GRATACAP.....	29
<i>Anthropological Exhibit of the U. S. National Museum at the Omaha Exposition</i> : DR. W. H. HOLMES.....	37
<i>Current Notes on Physiography</i> :— <i>The Lakes of France; Lakes of the Austrian Alps; The Lob Nor Controversy; Lake Mendota</i> : PROFESSOR W. M. DAVIS.....	40
<i>Current Notes on Meteorology</i> :— <i>Climatic Control of Transportation in Northern Russia; Kite Meteorology in the Antarctic; Auroras in London from 1707 to 1895</i> : R. DEC. WARD.....	42
<i>Current Notes on Anthropology</i> :— <i>The Archeology of Guerrero; The Quiche Language</i> : PROFESSOR D. G. BRINTON.....	42
<i>Scientific Notes and News</i> :— <i>Important Vertebrate Fossils for the National Museum; Professor Koch on Malaria; Bibliographical Data for the Title-pages of Books: General</i>	43
<i>University and Educational News</i> .....	51
<i>Scientific Literature</i> :— <i>Laisant's La Mathematique</i> : PROFESSOR ALEXANDER MACFARLANE. <i>Kingsley's Comparative Zoology</i> : PROFESSOR F. E. LLOYD. <i>The Phytogeography of Nebraska</i> : ELIZABETH G. BRITTON.....	51
<i>Scientific Journals</i> .....	55
<i>Societies and Academies</i> :— <i>The Philadelphia Academy of Natural Sciences</i> : DR. EDW. J. NOLAN. <i>Torrey Botanical Club</i> : E. S. BURGESS.....	56

IN the prevailing scientific activity of the world the enduring vigor which we display in finding out all we can know about ourselves, this point in space we inhabit, what it contains, what it has contained, and what it may be made to contain, the Museum appears as perhaps the most significant emblem of our untiring industry.

If I may use my own language employed in another connection, the museums "appear like monoliths over a country which has become imbued with the scientific spirit, here raised to the memory of some local worker, there stately monuments of cosmopolitan learning, which in the centers of commercial activity preserve alive the genius and the zeal of original research. All are nurtured by the same love of the actual and its relations and laws, and all embody the incessant spirit of observation, comparison and knowledge.

"In the United States, favored by natural causes, the variety and wealth of our natural resources, by the adoption of scientific instruction in our schools, by the practical habits and cultivated instincts of observation of our people, the liberality of general and State governments in organizing surveys, and the helpful impulses of lyceums, lectures and societies, scientific museums increase rapidly."

MSS. intended for publication and books, etc., intended for review should be sent to the responsible editor, Professor J. McKeen Cattell, Garrison-on-Hudson, N. Y.

\* Read before the Gamma Chapter of the Phi Beta Kappa, April 26, 1898.

But when we consider the collecting instinct of man, something primordially allied to the gathering habits of a squirrel or a pack-rat, the chromatic eccentricity of an oriole or a bower-bird, or the vandalism of a shrike or a racoon, we may anticipate that, unregulated, it can produce the most fantastic and inane combinations of objects. And it does. The comment of a German writer, Wilhelm Bürger, on the misleading collections of the art museums of his own country should be profitably quoted. He says: "Our museums are the veritable graveyards of art, in which have been heaped up, with a tumulous-like promiscuousness, the remains of which have been carried thither. A Venus is placed side by side with a Madonna, a satyr next to a saint. Luther is in close proximity to a Pope, a painting of a lady's chamber next to that of a church. Pieces executed for churches, palaces, city halls, for a particular edifice, to teach some moral or historic truth, designed for some especial light, for some well studied surrounding, all are hung pellmell upon the walls of some non committal gallery—a kind of posthumous asylum, where a people no longer capable of producing works of art come to admire this magnificent gallery of débris."

But these mere failures of perception, these obvious incongruities of place, time and concept, are less detestable certainly than the ceaseless association of things which have no conceivable relations. To use a word thrown now into organized speech by the peculiarities of certain literary productions of our day, there is a latent 'yellowness' in men which can be insidiously evoked to some sort of response, and there is a phase of attention which emits, as it were, a reflected gleam of puerile pleasure, when a museum cabinet summons its notice to the skull of a murderer at rest along side of a brick from the Great Wall of China, the tooth of a shark

inoffensively placed in juxtaposition with the thighbone of the diver whose fate it determined, or the jaw of a gorilla by the side of William Tell's arrow, if not a wax model of the original pippin it so luckily transfixed.

These are not purely aggravatedly imagined cases, devised for your amusement. The provincial museums of England, for instance, were long a scandal. Poorly supported, absurdly arranged, without discriminating curators, they became mixtures of oddities, monstrosities and perversions. Listen to this well-informed and well-weighted recital from the lips of W. Boyd Dawkins: "In one instance which occurs to me you see a huge plaster cast of a heathen divinity surrounded by fossils, stuffed crocodiles, minerals and models of various articles, such as Chinese junks. In another a museum unit takes the form of a glass case containing a fragment of human skull and a piece of oatcake labeled 'fragment of human skull very much like a piece of oatcake.' In a third wax models are exhibited of a pound weight of veal, pork and mutton-chops, cod-fish, turnips, potatoes, carrots and parsnips, which must have cost the value of the originals many times over, with labels explaining their chemical constitution, and how much flesh and fat they will make. \* \* \* \* In very many museums art is not separated from natural history, nor from ethnology, and the eye of the beholder takes in at a glance the picture of a local worthy, a big fossil, a few cups and saucers, a piece of cloth from the South Seas, a war club or two, and very possibly a mummy." As an American analogue some of us may recall the Athenæum in Nantucket town with its museum of mingled odds and ends, models, whale jaws, implements, antiquities and dirt, though there our literary intuitions appreciate its extreme availability for the pen of Miss Wilkins or Sarah Orne Jewett.



But this state of affairs has sensibly vanished. Except in those horrifying aggregates of things in heaven, and on the earth, and in the waters under the earth, to which a commercial spirit has promptly affixed the name of dime museums, such disordered collections are only met with in juvenile clubs and country lyceums, where the bucolic appetite feeds rejoicingly on wonders. Today enlightenment growing with each rising and setting sun, curiosity whetted by the unflinching experience and reading of every hour, delight animated by renewed accessions of pleasure at each new object of interest, each new principle of nature, each new sign of scientific conquest of the world—all these, enlightenment, curiosity, delight, demand that the Museum shall become a teacher, an expounder, a camera. They demand from it speech and learning and illustration, philosophy and order and a deepened willingness to lead the daily run of men and women into avenues of beauty, into avenues of knowledge, into avenues of stimulating suggestion. They ask that it be a *conspectus* of things, such as embodies the *consensus* of modern scholarship.

To the great multitude which from circumstances of life, from neglect, from penury, from the hard fulfillment of material tasks, from lethargy, from congenital deficiency, or from whatever other cause in the wide prospect of contingency which befalls us all, have not received the gift of education—to this multitude the great Museum comes with some sort of recompense for its denial. Great indeed! above college or university or pulpit or cathedral if from the mind of that multitude, thankful and patient, it dispels darkness and by the mere spectacle of art or nature or science, in its luminous thought-giving halls, pours upon them the light of recognition and of knowledge.

Yet the functions of a museum are far from exhausted when it has expended all its

available power to instruct and cultivate the people. It must minister to the needs of the investigator, stimulate his efforts and publish his results. The Smithsonian Institution of Washington, so far as it held for years undeveloped and poorly materialized the germ of the present National Museum, began its most beneficent career as an instrumentality of research. Its beneficial relations to the public as a curator of collections which it arranges, labels and displays appeared long subsequent to its office as a means of scientific investigation. In fact, in the new idea assuming more large and ambitious proportions each day, the museum in its wide relation to the world around it embodies the character of the collector, expositor or lecturer and the original investigator.

In character museums can be as various as the diverse fields of interest society or nature present. Art museums, in a modern sense, began with that of Cosmo de Medici in Florence, at the beginning of the sixteenth century, the Museum of the Uffizi. These rapidly multiplied and with their multiplication underwent specific differentiation. Museums arose devoted to the work of one man, as the Thorwaldsen Museum in Copenhagen, the Wiertz Museum at Brussels, the Donatello and Michel Angelo Museums in Florence. Museums of art became cabinets of curiosities, rarities, gems, handicraft, as the Cluny Museum in Paris, the Green Vaults at Dresden, the collection in the Tower of London, the Museum of the Hohenzollerns in Berlin, and that of the city of Paris, of all of which Dr. Goode says: "Such collections cannot be created. They grow in obedience to the action of natural law, just as a tree or a sponge may grow." Historical museums attach themselves naturally to the foregoing, and of these the list is long and intricate. Groups represent the histories of cities or provinces, as that of the Mark of

Brandenburg in Berlin, those of Paris, Antwerp, Brussels, local museums of antiquities, devoted to a country or race, or era, as the Etruscan Museums at Florence and Bologna, the Cairo, the Constantinople and Athens museums; and yet others perpetuate the lives and achievements of great men, as the Dante Museum in Florence, the Goethe Museum in Weimar, the Beethoven Museum in Bonn, while picture galleries devoted to the works of artists, the ramifications of dynasty or family, the miscellanies and relics of governors, generals, statesmen, enmeshed within the historical associations of one period, form still other classes, as the collection in Old South Church, Boston, the Kunst historisches Museum in Vienna, illustrating the history of the Hapsburg, and the Musée Historique de Versailles.

The museum of science is that form of the museum which now engrossingly attracts notice, because this is the moment of its highest development, and because science, ceaselessly advancing with all the abetting impulses of exploration at its command, is penetrating everywhere, and before the solvent powers of its touch and its genius the world, the universe and even the life of man fall into orderly and necessary arrays of evolutionary stages. Science is the enduring sensation of our day. The scientific museum embodies, when perfectly realized, when meeting its ideal requirements, the incarnation of the scientific mind, that mind, at its best, inexorably calm and of almost incalculable vision.

The Scientific Museum, if I may venture an epigram, is the expression of the Aristotelian mind. To the Stagyrte, in his classifying instinct, his analytical sagacity, so prophetic of the modern spirit, the Museum was doubtless a distinct idea. It would seem, conscious as we are of the vivid insight of the Aristotelian brain and its wise

reliance on accumulation and comparison, that we might fix the rise of the scientific museum concept in his time, in his thought. It was, indeed, the triumphs of Alexander that awakened a profound movement of questioning in the culture of Athens. The new worlds, abounding in strange unheard of, unimagined phenomena, with their breadth of climate, novelty of scenery, peculiarities of race, plants and animals, which Alexander revealed, startled the innovating fancy of Greece with peculiar interest. Humboldt, in his colossal grasp of all the aspects of our planet, has written of these events: "The extension of the sphere of new ideas was owing to the magnitude of the space made known, and to the variety of climates manifested, from Cyropolis on the Jaxartes (in the latitude of Tiflis and Rome), to the eastern delta of the Indus at Tira, under the Tropic of Cancer. To these we may further add the wonderful diversity in the configuration of the country, which alternated in luxurious and fruitful districts, in arid plains and snow-crowned mountain ranges, the novelty and gigantic size of animal and vegetable forms, the aspect and geographical distribution of races of men of various color. \* \* \* In no age, excepting only the epoch of the discovery and opening of tropical America, eighteen centuries and a-half later, has there been revealed, at one time and to one race, a richer field of new views of nature or a greater mass of materials for laying the foundation of a physical knowledge of the earth and of comparative ethnological science." Again, this sublime philosopher designates some scientific results of Alexander's conquests in these words: "Besides the knowledge of products which soon became objects of universal commerce and many of which were transported by the Seleucidae to Arabia, the aspect of a richly embellished tropical nature speedily yielded the Greeks enjoyments of another

kind. The gigantic forms of hitherto unknown animals and plants filled their imagination with the most exciting images. Writers, whose dry scientific style is usually devoid of all animation, became poetic when they described the characteristics of animals, as, for instance, elephants, or when they spoke of the height of trees whose summits cannot be reached by the arrow in its flight and whose leaves are larger than the shields of the infantry; of 'the bamboo, a light feathery tree-like grass,' 'each of whose jointed parts (internodia) may serve for a many-oared keel;' or of the Indian fig-tree that takes root by its branches and whose stem has a diameter of twenty-eight feet, and which, as Onesicritus remarked, with much truth to nature, forms 'a leafy canopy similar to a tent, supported by numerous pillars.'"

Those splendid accessions to the knowledge of Greek students, with their probable accompaniments of collections, might naturally have developed the museum idea in Alexander's friend Aristotle, the immortal type of the spirit of research. Professor Flower has alluded to the probable beginnings of museum collections in the "preservation of remarkable specimens, sometimes associated with superstitious veneration, sometimes with strange legendary stories, in the buildings devoted to religious worship. The skin of the gorillas brought by the navigator Hanno from the West Coast of Africa, and hung up in the temple at Carthage, affords a well-known instance."

When learning revived; when, to use the exquisite language of Pater, "the desire for a more liberal and comely way of conceiving life, make themselves felt, prompting those who experience this desire to seek first one and then another means of intellectual or imaginative enjoyment, and directing them not merely to the discovery of old and forgotten sources of this enjoyment, but to divine new sources of it, new

experiences, new subjects of poetry, new forms of art"—then sprang up, too, with the new evidences of mental regeneration the desire of keeping together beautiful and curious things.

Naturally, the first developments were in the nature of collections of art, the bringing together in groups sculpture and paintings and antiquities. Since the revival of learning began with the passionate devotion to classical literature the rich and learned turned with an appropriate ardor to all that could be obtained in that buried field of emotion, grace and eloquence. And since the art of the pagan, as Taine urges, brought the revivifying breath that made Christian art beautiful and manifold, creative and cosmopolitan, so the ancient things of Greece and Rome were enviously gathered. Books and libraries and statues in museums were rapidly accumulated. It was a liberal prince, a rich merchant, a trading monarch, a distinguished physician, or the egotism as well as the enlightenment of a noble, that started the first growth of museums. Stones, gems, shells, fish and animals quickly assumed places in museum collections, and the long hidden instinct of natural study hastened hither and thither on land and sea the zealous and wondering collectors. Once started, the flame of desire spread quickly, and, everywhere fed by the oil of rivalry, men and women in high or in influential stations collected and collected and collected, turning their homes into storehouses of curiosities and maddening arrays of impossible associations. This very incongruity stimulated further efforts at an extravagant amplitude of contents and only as time passed on was a separation effected by which the provinces of Natural History and Art proper secured mutual independence. We can clearly realize the effectual assertion of temperament in such collections; how one man or woman with an in-born and now indulged love of nature col-



lected the objects of nature alone, and another the beautiful or industrial products of man. So drawing apart by a mutual repulsion the Museums of Natural History became separated from those of Art, and the fantastic combinations of a statue sprouting from a galaxy of shells or paintings alternating with fish skeletons and minerals or a bronze medallion encircled with bird's feathers happily disappeared.

The earliest museums were all private affairs prepared with some relevancy to the owner's tastes or the prevailing fashion of collectors. It was much later that clusters of individuals organized as societies made the building up of a Museum a part of their duty. Samuel Quickelberg, of Amsterdam, a physician, published at Munich in 1565 one of the first printed catalogues of such a museum; also at the same time Conrad Gesner described the cabinet of Johann Kentmann, a physician of Torgau, in Saxony, which consisted of 'minerals, shells and marine animals.'

Amongst the whimsicalities connected with this subject, the following extract from Professor Flower's address before the British Association for the Advancement of Science in 1889 fully reveals their amusing character. Professor Flower has brought to light an entertaining specimen page of a catalogue compiled by the two Tradescants, father and son, in 1656 and entitled 'Museum Tradescantium; or a Collection of Rarities preserved at South Lambert near London;' item, 'Some Kindes of Birds their Egges, Beaks, Feathers, Clawes and Spurres; Divers sorts of Egges from Turkie, one given for a Dragon's Egge; Easter Egges of the Patriarch of Jerusalem; Two Feathers of the Phoenix Tayle; The Claw of the bird Rock, who, as Anthors report, is able to trusse an Elephant; Dodar from the Island Mauritius; it is not able to fly being so big;' Again 'Garments, Vestures, Habits, and Ornaments,' again 'Mechanick,

Artificial Workes in Carvings, Turnings, Sowings, and Paintings,' wherein we find the 'Pohatan, King of Virginia's habit, all embroidered with shells or Roanoke,' and the 'Cherry-stone upon one side S. George and the Dragon perfectly cut, and on the other side 88 Emperours' faces,' and yet another 'cherry-stone, holding ten dozen tortoise-shell combs made by Edward Gibbons.'

To-day the Museum of Science stands or ought to stand as the representative expression of the progress of science. Its possible dimensions are difficult to overestimate, for its proportions should be correlated with, and reflective of, all that learning thinks and nature shows in the vast provinces of creation. It is, I think, with supreme justice that Professor Flower boldly asserts that "it has only been the difficulties, real or imaginary, in illustrating them which have excluded such subjects as astronomy, physics, chemistry and physiology from occupying departments in our National Natural History Museum; while allowing the introduction of their sister sciences, mineralogy, geology, botany and zoology."

But it can also be profitably remembered that the maintenance of any stupendous accumulation of material, and its associated activities in lectures, publications and keepers involves gigantic expenditures not to be always well distributed or wisely administered. Therefore for very practical reasons the experimental sciences are not represented in our museums, withdrawing by a natural refinement of sympathy to schools of science, colleges, and special institutes, and the museum of natural history more distinctively presents to the public the manifestations of life, even of mind, and the inorganic elements and their combinations.

I have said that the museum exercises three functions, that of the collector, the



lecturer or expounder and the investigator. These three present the rounded outline of its attitude to the visitor, the pupil and the scientist. Let us examine these aspects of its nature and economy.

#### THE MUSEUM AS A COLLECTOR.

The museum furnishes the most substantial guarantee against the loss or scattering of valuable specimens. It naturally induces the deposit of private collections. It becomes in a short time the refuge of all sorts of cabinets, and, from the mutations of circumstances in private fortunes, it stands in the field as a desirable purchaser of private treasures. So initially in the ordinary development of the museum the collections come first. The British Museum, which now stands preëminent as the most complete embodiment of the museum idea, began its career with such a nucleus in the Cottonian manuscripts, coins, medals and antiquities, the Arundel and Harleian manuscripts, and the Sloane collection of natural history, antiquities and books. The National Museum of the United States, which developed within the franchises and purposes of the Smithsonian Institution, came into material objectivity with the collections, mostly minerals, of Smithsonian himself, to which ensuing years brought large additions from the Pacific Exploring Expedition, Perry's Expedition to Japan, the Pacific Railroad Survey, the Mexican Boundary Survey, the Surveys of the Army Engineer Corps and the Centennial Exhibition of 1876.

The Field Museum of Chicago sprang into sudden prominence from its huge heritage or acquisition of the dismembered sections and débris of the Chicago Fair, and our own American Museum of Natural History virtually was born when it was welcomed to Central Park by Commissioner Green, and deposited its collections in the old arsenal at 64th Street and Fifth Avenue in 1869.

Those walls, which had reverberated to the martial grounding of arms in 1863, when riot held the throat of New York in its bloody fist, then witnessed a more peaceful invasion of birds and beasts, a silent procession, from whose mute forms, as named and classified, flow the tranquillizing influences of study.

The museum should also profitably invite to itself the numerous men who have, by accident or exploration, come into possession of beautiful or instructive objects. It centralizes the divergent impulses of discovery and brings into substantial importance the trader and dealer in natural productions. It is a sea of reception into which pour from all levels of observation the specimens which illustrate faunas and florae and natural resources, mineral wonders and curiosities. The purchase of new objects, indeed the admission of new material, must be guided by the best professional advice, professional advice also that is known to be regulated by disinterested motives. No material should be secured which simply duplicates matter already on exhibition for the meretricious reason of its *slightly* greater elegance or splendor. Fundamentally museums as collectors are to instruct, though the æsthetic sense, of course, need not, on that account, be blunted or suppressed. Indeed, it is true that the most perfect things in nature are often the most instructive, and, at any rate, exhibits should challenge attention by their average superficial beauty. So much is to be bought and so much expended in all directions that money is wasted by buying what is already in evidence.

The line of development in a natural history museum cannot always be evenly maintained in all departments. When Zoology, Geology, Mineralogy, Ethnology and Botany are located under the same roof with interests enthusiastically defended by as many groups of curators there is inevi-

table collision, and the provident direction of all is a task demanding a wise sense of discrimination and responsibility, as well as a rather judicial indifference to special pleading and selfish aggrandizement.

But while the collection of specimens can be regulated by ordinary experience and skill, the exhibition of specimens demands an order of analytical sagacity and sympathetic insight not ordinarily possessed. Dr. Goode, in his famous epigram, declared that a museum was a collection of labels illustrated by specimens. This is not to be interpreted that a museum is to become a hall of signs. But it does mean that there shall be nothing left to surmise or guesses, but everything shall be named, and a further extension of its meaning implies that the combination of labels and objects shall be educational. The function of the museum as a collector encloses its function of so selecting and arranging objects as to educate. The selection of such objects as present a development or illustrate conditions, stages of growth, environment, supplementary associations, climate, position, form a visual lesson, become encyclopædic, and leave a deposit of impressions which express the science of the subject.

Let us take two concrete examples : A collection of shells can be minutely labelled and laboriously displayed, but how little does a scientific label, with the name of a genus and a species, tell the ordinary visitor ! It supplies only an additional means of mental confusion. But let a group of shells be represented by a few well-selected and graded specimens showing stages of growth ; let a general label explain their general characters, affinities and possibly uses ; let a map show in colored areas their distribution, while a few prints, photographs or drawings represent the regions in which the shell lives, the appearance of the animal alive, with a possible dissection, and without going further the whole section be-

comes vitalized, and a living impression, measurably perfect and permanent, has been produced. Such a method of exhibition evokes the nascent properties of the young naturalist, while it holds the agreeable attention of the plainest visitor. James Whittaker, of Oldham, was 'a hand' in a cotton mill, who from hearing some one say, as he picked up a piece of coal shale, that there was a fish scale in it, was led to collect coal plants and reduce them to thin films by rubbing them down on the kitchen floor so as to reveal their minute structure. And this man's collection afterwards was used by Professor W. C. Williamson in his memoirs on coal plants published by the Royal Society. This story illustrates the supreme consequences of a suggestion. How wonderfully suggestive and stimulating may a museum collection become to congenial minds ! Of course, in the case of Whittaker, as of Edwards, his Scotch analogue, the inborn tendency might have spontaneously, sooner or later, pushed their minds into such lines of study and research, but the dormant flame would have been in all cases more quickly kindled in the presence of a thoughtfully arranged exhibit. Such exhibits are mute pedagogics.

Again, a collection of minerals fails to express the ideas and lessons of mineralogy if it is a formally arranged succession of ticketed and labelled specimens. Mineralogy admits of a many-sided installation. It would be advantageous to display minerals in reference to their history, their crystallization and physical properties, their distribution and their specific multiplicity and characters. Usually the latter method alone is used, and then it frequently takes the form of a succession of specimens rather niggardly labelled. Primarily, it would seem that the object of a collection is to lay open the scientific aspects of the subject with some suggestions, introduced wisely

and with a proper sense of restraint, of the elaborations of the science.

Mineralogy offers a field of attractive experiment and has in some museums reached stages of taxonomic complexity. The history of minerals might very properly form the introductory stage with examples of ancient nomenclature: that followed by Theophrastus, Aristotle, Dioscorides and Pliny; then the later and mediæval period with reference to the lucubrations of Marbodius, Albertus Magnus and Agricola; and then the crystallographic systemic period of Jamitzer, Steno, Bergman, Romé de Lisle, Haüy, Bernhardt, Weiss, Mohs, Newman, Whewell, Miller. Following this as a logical pendent would come an exhibit of crystals with an anatomical analysis of their parts, somewhat as Professor Crosby has devised in the Museum of the Boston Society of Natural History. The physical properties, color, lustre, hardness, refraction, fluorescence, fusibility of minerals and illustrations of optical principles would be incorporated in this section. Finally, their distribution, which, under lithological and economic supervision, would show the occurrence of the silicates, crystalline schists, marbles, limestones, elastics, eruptives, and the zones and centers of deposit of the useful or valuable ores, all illuminated by diagrams, maps and photographs. Then would follow the mineral cabinet, a display of expressive and beautiful specimens, subordinated to a chemical system, in which the design so well illustrated by Professor Egleston, in the cabinet of the School of Mines, of showing the varieties of a mineral, often so extreme and perplexing, would receive complete vindication. It seems impossible that a conspectus of minerals, arranged upon so wide and exhaustive and illuminative a plan, would not leave the attentive mind notably strengthened and informed. Similarly, in the various departments of zoology the most at-

tractive and intelligent development of visual instruction could be followed with most fascinating and novel results. In geology, of which it has been lately remarked by Professor A. Geikie with relation to the extraordinary vitality of that science in the United States that "surveys, professorships, museums, societies, journals in almost every State are the outward embodiment of the geological zeal that appears to animate the whole community;" in geology the scheme of historical development might also be partially followed, while an elaboration in diagrams, photographs and discriptions of the morphology and significance of the groups of fossils should take precedence of an endless display of species. In large and capacious halls the systematic and the explanatory methods might both be utilized and combined. And, finally, in this connection, there seems a fascinating propriety in making a museum also a gallery of biography; the faces and some short sketch of their lives of the great investigators and systematists would seem appropriately placed amidst the teeming results and facts their genius and industry have produced and discovered.

The mechanical details of exhibition require all the charm, convenience, and even beauty, which the resources of the institution permit, and especially, should all architectural construction bend subserviently to the underlying necessity in every museum, the best illumination. Light, bathing everything with luminous clearness, is the very symbol of the museum purpose.

L. P. GRATACAP.

AMERICAN MUSEUM OF NATURAL HISTORY.

(To be Concluded.)

---

ANTHROPOLOGICAL EXHIBIT OF THE U. S.  
NATIONAL MUSEUM AT THE  
OMAHA EXPOSITION.

THE frequency with which the National Museum has been called upon to prepare



exposition exhibits has made it somewhat difficult always to secure fresh and interesting material for display. To obviate this difficulty in the Anthropological Department, it was decided to assemble the limited group of exhibits required, on a plan differing essentially from that adopted at previous expositions.

Heretofore the materials have been brought together in a somewhat disconnected way to illustrate particular peoples, or especial arts or industries. On the present occasion the activities of man are treated from the point of view of their development. The various lines of progress are represented by series of objects each individual typifying a step in the industrial and intellectual evolution of the race.

As the exhibits required had to be drawn from all divisions of the Department, a single series of objects in many cases being made up from the collections of two or more divisions or sections, members of the anthropological staff were called upon to act as committees in assembling the exhibits in which they were personally concerned. The full resources of the Museum were thus drawn upon, yet the objects taken were so few in number as not to interfere with the present museum installation.

Each series of exhibits epitomizes a single branch of art or industry and occupies a single case front or a fraction thereof, and may thus be conveniently seen at one view. The scheme of treatment or presentation is just such as the systematic student would adopt in writing the history of the subject, beginning with the inceptive stages and moving forward step by step to the highest development. The following subjects are presented, the series beginning at the left in the cases and progressing toward the right:

*The use of fire.* The story, illustrated in part by means of colored drawings, begins with the fire of volcanoes and lightning and the carrying of firebrands from these sources

for rekindling; it is continued in a series of exhibits showing progressive steps in the making of fire which is illustrated by rubbing sticks, revolving drills, flint and steel, the lucifer match and devices for producing the electric spark.

*Illumination.* Two series of objects are shown, the first illustrating the torch in its many forms, arranged progressively; the second the lamp, beginning with the stone cup with oil and wick, and ending with the argand burner and the arc light.

*Fishing.* Of the various exploitative activities, so necessary to the sustenance of the race, only one group—the arts of fishing—is represented, others having been omitted for want of space. Series 1 illustrates the dart in its multiplicity of forms, series 2 the various toggle devices, series 3 the hook, and series 4 the sinker.

*Domestic arts.* Household arts are represented by four series, one epitomizing the history of cooking, and three illustrating utensils and devices employed in eating and drinking—the cup, the spoon and the knife and fork.

*Tools of general use.* The history of the more essential tools of human handicraft is epitomized in seven series, each beginning with the simplest forms—mere splinters and masses of stone—and ending with the highest forms—the marvelous machine-operated tools of to-day. These tools are the hammer, the ax, the adz, the knife, the saw, the drill and the scraper.

*Weapons.* Weapons of war have performed a most important part in the history of progress, and the steps that led up from the stone and club, held in the hand, to the steel sword and the compound machine gun are strikingly suggested in the two series presented: 1. Weapons for use in the hand—piercing and slashing weapons; and 2. Projectile weapons—the bow and arrow, the cross-bow and the pistol and gun.



*Transportation—marine.* The history of water transportation is epitomized in four of its leading lines of elaboration: 1. The hull, beginning with the log raft and ending with the magnificent substructure of the modern ship (represented by models). 2. Hand propulsion—the pole, the paddle and the oar (in part models). 3. The paddle wheel (models); and 4. The screw propeller (models).

*Transportation—land.* Land transportation is shown in six series (models): 1. The burden bearer, man and beast. 2. The sliding load. 3. The rolling load. 4. The wheeled vehicle. 5. The steam locomotive; and 6. The railway track.

The great group of elaborative activities concerned in manufacture is illustrated by four exhibits: the ceramic art, the textile art, metal work and sculpture.

*Ceramic art.* In this exhibit are included four series: 1. Implements and devices employed in manufacture—modeling tools, decorating tools, stamps, molds and the throwing wheel. 2. The vase, showing progressive steps in shaping and decorating and in the results of firing on paste and surface finish. 3. Glass making in its relation to ceramics; and 4. Enamel.

*Textile art.* Weaving is represented by three series: 1. The spindle. 2. The shuttle; and 3. The loom, the latter illustrating in a remarkable manner the rapid transition from primitive to highly developed appliances.

*Metal work.* The history of this important branch is partially presented in three series. 1. Metal reduction. 2. Products of manufacture showing progressive order in processes, forms and embellishments; and 3. Tools and appliances of manufacture.

*Sculpture.* The stone-shaping arts begin with the simplest known artificial modifications of natural forms, and advance to the achievement of the highest ideals, as represented in Greek art. Four series are shown:

1. Prehistoric stone shaping (Europe). 2. Aboriginal American sculpture. 3. Sculpture of civilized nations; and 4. Implements used in stone shaping. Series 1, 2 and 3 are separated for the purpose of contrasting the work of distinct periods and peoples.

*Photography.* This art, the product of advanced culture, is represented by three series of objects, epitomizing the development of: 1. The camera. 2. The lens; and 3. The picture.

*The book.* A limited series of objects is devoted to the history of the book; the method of assembling the several parts—the tablets and sheets—being the feature considered.

*Electricity.* Electrical inventions, representing one of the youngest and most marvelous branches of human activity, are shown in three limited series: 1. Experimental apparatus (Henry). 2. Transmitting apparatus (Morse and subsequent inventors); and 3. Recording apparatus.

*Music.* Four series are devoted to the history of as many varieties of musical instruments: 1. Wind instruments. 2. Reed instruments. 3. Stringed instruments; and 4. Percussion instruments.

The system of arranging these series is such as to make them fully intelligible to the average museum or exposition visitor. A large label or sign is framed and placed outside each case at the top; a general label for each exhibit, giving briefly the history of the subject treated, is framed and placed inside the case. Also a label explaining each progressive series is placed at the beginning of the series, and individual labels describing the specimens are placed with the specimens.

Associated with these developmental series are a number of life-size figures, modeled in plaster and appropriately costumed, intended to illustrate the practice of the arts in their primitive stages. They

give a vivid impression of primitive processes and serve to contrast these with the methods and machinery of advanced civilization. The subjects presented are as follows :

*The fire maker.* A Ute Indian making fire by twirling between the palms of his hands a wooden shaft, with its point set into a conical depression in a second piece of wood.

*The driller.* An Eskimo man, in reindeer skin costume, using a bow drill for perforating an ivory ornament.

*The flint flaker.* A Powhatan Indian roughing out stone implements from quartzite boulders.

*The hominy huller.* A Southern Indian woman pounding corn in a wooden mortar. Figure in plaster with costume restored from drawings made by members of the Virginia colonies.

*The skin dresser.* A Sioux woman using a scraping or graining tool in preparing a buffalo robe.

*The potter.* A Papago Indian woman modeling an earthen vessel.

*The metal worker.* A Navajo Indian making silver ornaments. Processes probably, in part at least, introduced by whites.

*The belt weaver.* A Zuni girl with primitive loom weaving a belt.

These exhibits form a part of the series now in course of preparation for the National Museum, and are mere outlines of the subjects as they will finally be presented. It is conceived that a measurably full series of such exhibits will be of high educational value, giving a comprehensive notion of a large number of the greater facts of anthropology. By no other scheme of display of objective material can the whole career of the race, especially of its intellectual development—its greatest characteristic—be so clearly set forth. The objects are not assembled chronologically, but pertain to all times and to all peoples. The

place of each specimen in the series is determined by its estimated relation to the successive levels of culture; and the exhibits when completed may be taken to illustrate the full range of human accomplishment as it stands to-day or as comprehending the entire human period. These exhibits thus present the whole scope of human achievement, so far as human handiwork can express it, and serve at the same time to indicate with approximate accuracy the main steps of progress made by the race in its tedious ascent from lowest savagery to highest civilization.

W. H. HOLMES.

CURRENT NOTES ON PHYSIOGRAPHY.

THE LAKES OF FRANCE.

ANDRÉ DELEBECQUE, of Thonon, Haute Savoie, France, has for some years past devoted himself to the study of the lakes of his country, on which he has already written fifty odd papers. He now produces a handsome monograph, 'Les Lacs Français' (Paris, Chamerot et Renouard, 1898), the most elaborate work of its kind yet published. All the lakes of France, over 400 in number, are described; the larger ones being studied as to location, depth, form, deposits, temperature, color and composition of water, origin of basins, and changes due to natural processes. The volume contains 22 maps and 153 figures. Under lake sediments it is well to note that, except close to the shore lines, lake bottoms are covered with an impalpable alluvium, quite like the sandstones that are often described under the head of lacustrine deposits in the Rocky Mountain region. The sub-lacustrine ravines, by which inflowing streams of low temperature and bearing glacial silts descend to the bottom of the larger lakes down the slope of their deltas, are interesting features; they raise the question whether some other condition than 'continental elevation' may be found to

explain the much greater ravines by which the edges of continental shelves are so often notched. The Rhone, entering Lake Geneva, is visible for a little distance by its whitish color in the clear water of the lake; but it suddenly sinks and disappears about 500 feet out from its mouth. Judging by the texture of bottom deposits along the path of the descending river, its velocity at a distance of 7 kilometers from the head of the lake and at a depth of 250 meters must be 0.20 m. a second.

#### LAKES OF THE AUSTRIAN ALPS.

THE text by Richter to the second part of the *Atlas der österreichischen Alpenseen* (1896) appears in the *Geographische Abhandlungen*, edited by Professor Penck, of Vienna (Vol. VI., No. 2, 1897). It describes and explains the origin of the lakes and gives a detailed discussion of their temperatures. The lakes of the Drave basin are ascribed rather to barriers of drift and torrent fans than to glacial action, thus giving another example of the different conclusions as to the competence of glacial erosion reached by detailed local study and by generalizations at a distance. The Millstatter See, for example, is cut off from the aggraded valley of the Drave by the torrent fan of the Lieser. Two small lakes, Afritzen and Brenn, are similar in origin to the lakes of the upper Inn, which were explained some years ago by Heim as the indirect result of the capture of headwaters of the Inn by an encroaching Italian stream. Several of the deeper lakes show a slight rise of temperature in the bottom waters during the spring months, which Richter explains as the result of conduction of the heat from the earth's crust after the active cooling of the surface waters in winter has ceased.

#### THE LOB NOR CONTROVERSY.

UNDER the above title, the (London) *Geographical Journal* for June, 1898, contains

an account, based chiefly on the work of Russian explorers, of the shallow lakes in the desert basin of Eastern Turkestan. The point at issue is: Which one of the several lakes of the region shall be identified as the Lob Nor of the Chinese maps; no lake being called by this name among the people of the region. This controversial matter is of less general interest than the physical features which are so well adapted to lead to controversy. A vast barren aggrading plain of sand and clay, occupying a great basin between enclosing mountains; fickle rivers which run far forward in flood and wither away in drought, occasionally turning into new channels and wandering a hundred miles from their abandoned beds; wandering sand dunes and growing deltas, disputing possession of the faint depressions with extensive reedy marshes and shallow shifting lakes; the lakes now brackish, now salt, at one time expanding, at another shrivelling; even the villages of uncertain mind, deserting an old site for a new one when invaded by dune, marsh or lake. A centenarian told one of the Russian explorers that he would not have recognized the country of his boyhood if he had returned there in his old age after spending his life abroad. Controversy naturally arises in such a geographical environment. It would then be with a new meaning that the returning traveller would sing: 'There's no place like home.'

#### LAKE MENDOTA.

THE use of lakes as biological stations by our inland universities promotes their physical exploration. The account of Turkey Lake, already noted in *SCIENCE*, is now followed by 'Plankton Studies on Lake Mendota,' by Birge (*Trans. Wisc. Acad. Sci.*, XI., 1897, 274-448, of which 286-300 are on lake temperatures). The depth of the lake is 18 meters. In May there is a rapid gain of heat through the whole water body; dur-

ing mid-summer the surface waters reach a temperature of 23° C., the bottom waters being 14° or 15°. The lake is at this time in stable equilibrium and the stagnant bottom waters are unfit for most forms of life. But by the end of September the surface has cooled so that a uniform temperature prevails from top to bottom; then gales easily overturn the water body and it slowly cools as a 'homothermous' mass to the winter minimum.

W. M. DAVIS.

CURRENT NOTES ON METEOROLOGY.

CLIMATIC CONTROL OF TRANSPORTATION IN  
NORTHERN RUSSIA.

FROM a recent book, entitled 'A Northern Highway of the Tzar,' by Trevor-Battye (London, Constable, 1898), there is much of interest to be learned concerning the marked control which the climatic condition of northern Russia in October exert over transportation and over the occupations of the inhabitants. October is known in that region as the Rasputnya season, Rasputnya meaning literally 'the separation of the roads.' At this season 'the first frosts have thawed and the first snows melted,' streams of broken ice block the rivers, the morasses are like quagmires; 'the tracks, where any advance has been attempted upon old forest bog, a mixture of treacle and glue.' There is an almost complete interruption of travel, owing to the condition of the roads and streams, until the settled frost of winter has united the land and the water into one solid frozen surface. "During the whole of October the government postal service is stopped, labor contracts are off, and the keepers of the stages are entirely freed from their usual obligation to supply the traveller with horses and sleighs." The control over transportation, here brought out in one of its aspects, is an important relation of climate and man which has not yet received the careful study it deserves.

KITE METEOROLOGY IN THE ANTARCTIC.

IN *Das Wetter* for May, Sprung advocates the use of kites on the proposed Antarctic expeditions, for the purpose of securing accurate data as to the vertical temperature gradient in high southern latitudes. At present the calculation of the pressures at altitudes of 2,000-4,000 meters in these latitudes leads to rather unsatisfactory results, owing to the uncertainty which exists concerning the actual temperatures prevailing there above the earth's surface. By the use of thermographs elevated on kite lines, as has been so successfully done at Blue Hill, it would be possible to obtain accurate temperature data from the free air at considerable altitudes, and these observations could be used in calculating the pressures aloft with a considerable degree of accuracy.

AURORAS IN LONDON FROM 1707 TO 1895.

A RECENT paper by Mossman, on 'The Aurora Borealis in London from 1707 to 1895,' (*Journal Scottish Meteorological Society*, Nos. 13 and 14, 1897), shows that the maximum numbers were observed in 1848, 1787, 1789 and 1872. Auroras are most frequent in October and April, and least frequent in December and June.

R. DEC. WARD.

HARVARD UNIVERSITY.

CURRENT NOTES ON ANTHROPOLOGY.

THE ARCHEOLOGY OF GUERRERO.

THE State of Guerrero lies on the Pacific, directly south of the City of Mexico. Before the Conquest it was peopled by the Mixtecs, who had a picture writing of their own; by the Nahuas, who were in the majority; and by lesser tribes. The Mexican antiquary, Orozco y Berra, writing thirty-five years ago, asserted his belief that within its area would be found one of the oldest sites of the American race (*Geografía de las Lenguas*, p. 239).

Especial interest, therefore, attaches to



Mr. William Niven's archaeological researches in that State. A sketch of them is given in the periodical *Modern Mexico*, for May, 1898. I have previously referred to his article on Omitlan (*SCIENCE*, December 10, 1897). West of Chihihualco he found ruins of a similar character, that is, built of stone with firm cement, on all the prominent ridges and hills. He also describes a cave containing old deposits of skeletons, some of the skulls singularly deformed by artificial means. A complete investigation of such relics is much to be desired.

#### THE QUICHE LANGUAGE.

This language is spoken in western Guatemala, and is a dialect of the Maya stock. For archæologists it has peculiar interest, as the ancient Quiches were quite civilized, and their mythology has been preserved in the remarkable 'Popol Vuh,' or National Book, edited by the late Abbé Brasseur de Bourbourg.

For these reasons, students will be pleased to learn that the British and Foreign Bible Society has published in Guatemala a translation of the Gospel of St. Mark into the tongue, the Spanish and Quiche being printed in parallel columns. The translation was made, I understand, by Mr. F. de P. Castells, agent of the Society, or under his supervision. Ordinary type is used, the phonetic values of the letters being sometimes from the Spanish, sometimes from the English, and the gutturals indicated by compound consonants or by different fonts.

D. G. BRINTON.

UNIVERSITY OF PENNSYLVANIA.

#### SCIENTIFIC NOTES AND NEWS.

##### IMPORTANT VERTEBRATE FOSSILS FOR THE NATIONAL MUSEUM.

PROFESSOR O. C. MARSH has recently transmitted from New Haven to the Director of the United States Geological Survey the fourth large instalment of Vertebrate Fossils secured in the West, in 1882-92, under his direction, as Paleon-

ologist of the United States Geological Survey in charge of Vertebrate Paleontology. The collection is packed in one hundred (100) boxes, and weighs over thirteen (13) tons. In accordance with law, the material will be deposited in the National Museum. This collection includes twelve skulls and other remains of the gigantic *Ceratopsia* from the Cretaceous; various *Dinocerata* fossils from the Eocene; a series of rare specimens of *Brontotherium*, *Elotherium*, *Miohippus* and other genera from the Miocene; a very extensive collection of Rhinoceros and other mammals from the Pliocene, as well as various interesting fossils from more recent deposits.

The other important collections of vertebrate fossils secured by Professor Marsh in the West for the Geological Survey, and previously transferred to the National Museum, may be briefly enumerated as follows:

- (1) Seventy-two (72) large boxes of Pliocene fossils, weighing about 7,500 pounds, were transferred December 31, 1886, and were stored in the Armory February 8, 1887. The record of these boxes is on file in the office of the Geological Survey, and the Smithsonian numbers of the boxes are 6,601-6,672.
- (2) Thirty-three (33) large boxes (weighing 6,960 pounds), of rare vertebrate fossils, ready for exhibition, were transferred July 17, 1891, and were placed in a case specially prepared for them in the National Museum, before the opening of the International Congress of Geologists held in Washington that year.
- (3) Forty-three (43) large boxes (weighing 4,380 pounds) of Pliocene vertebrate fossils were transferred April 17, 1896.

These various collections, with other smaller consignments transferred to the National Museum (255 boxes in all, with a total weight of over 20 tons), were secured under the special direction of Professor Marsh, as Paleontologist of the United States Geological Survey in charge of vertebrate paleontology, during 1882-92. The remaining collections thus made, and still at New Haven, will be sent to Washington as soon as their scientific investigation, now in progress, is completed.

## PROFESSOR KOCH ON MALARIA.

PROFESSOR KOCH, who, as we have reported, has recently returned from German East Africa, addressed the Colonial Society of Berlin on June 9th, on the subject of malaria in the tropics. He stated, according to the London *Times*, that he had found the study of Texas fever in cattle of the greatest assistance in casting light upon the nature and origin of tropical malaria. That cattle disease had been found to be transferred from one herd to another solely by the agency of that animal parasite, the tick. He had been able to infect sound cattle with ticks taken from diseased ones, and had succeeded in conferring immunity against Texas fever upon cattle inoculated with the ova of ticks taken from cattle which were suffering from the disease. Malaria offered many points of resemblance to Texas fever, and he had arrived at the conclusion that in the case of the human disease mosquitoes probably played the part which ticks played in the cattle disease. It was found that wherever there were mosquitoes there was malaria, and wherever, as in the case of a small island on the German East African coast, there were no mosquitoes there was also no malaria.

He had taken occasion to follow closely the course of cases of tropical malaria in which the use of quinine was dispensed with. He found that, contrary to the view hitherto accepted, the cases where quinine was not used showed that in malaria, as in other fevers, the readings of temperature followed a definite course. Moreover, it had been found possible by a microscopic examination of the blood of the patient to discover from the nature of the microbes it contained the precise stage of the development of the disease. This would be of the greatest importance, since everything depended upon the administration of quinine either shortly before the attack or very shortly after it. It would ultimately, he thought, be possible to administer quinine in a rational manner and so to avoid the injurious consequences of the quinine treatment. Quinine taken at the proper juncture undoubtedly stopped the malarial fever. It did so, not by killing the germs, but by arresting their growth. A rational and scientific employment of quinine, combined with the es-

tablishment of health resorts in the mountains, would rob tropical fever of many of its terrors. Professor Koch further discussed what is designated in German *Schwarzwasserfieber*. According to his view this fever is not connected with malaria at all, but is the result, in all probability, of the quinine treatment. In any event, there was no case of this fever in which it could be safely asserted that quinine poisoning was not present.

As to the possibility of securing immunity from malaria, he called attention to the fact that whole native tribes seemed to be proof against the infection. But if a natural immunity existed it was reasonable to hope that an artificial one might be created. It had been observed, for example, that persons who had suffered from malaria and had made a gradual and slow recovery without the aid of quinine often acquired entire immunity from the disease. In order that progress should be made in combating the ravages of malaria, it was indispensable that doctors trained in bacteriology and in the use of the microscope should be sent to East Africa. The administration of quinine by non-professional hands was a great mistake. If science were one day to cope successfully with this disease it would facilitate the prosperous development of some of the most fruitful districts in the world.

## BIBLIOGRAPHICAL DATA FOR THE TITLE-PAGES OF BOOKS.

THE Publishers' Association of Great Britain has adopted arrangements for the bibliographical details given on title-pages of books, which we reproduce here, as they are of special importance in the case of scientific books. It is to be hoped that they will be insisted on by men of science and followed by American publishers. The recommendations are as follows:

(1) *Date.*—(a) That the title-page of every book should bear the date of the year of publication, *i. e.*, of the year in which the impression, or the reissue, of which it forms a part, was first put on the market. (b) That when stock is reissued in a new form the title-page should bear the date of the new issue, and each copy should be described as a 'reissue,' either on the title-page or in a bibliographical note. (c)

That the date at which a book was last revised should be indicated either on the title-page or in a bibliographical note.

(2) *Bibliographical Note*.—That the bibliographical note should, when possible, be printed on the back of the title-page, in order that it might not be separated therefrom in binding.

(3) *Impression, Edition, Reissue*.—That for bibliographical purposes definite meanings should be attached to these words when used on a title-page, and the following are recommended: *Impression*.—A number of copies printed at any one time. When a book is reprinted without change it should be called a new *impression*, to distinguish it from an *edition*, as defined below. *Edition*.—An impression in which the matter has undergone some change, or for which the type has been reset. *Reissue*.—A republication at a different price, or in a different form, of part of an impression which has already been placed on the market.

(4) *Localization*.—When the circulation of an impression of a book is limited by agreement to a particular area, that each copy of that impression should bear a conspicuous notice to that effect.

*Addendum*.—In cases where a book has been reprinted many times, and revised a less number of times, it is suggested that the intimation to that effect should be as follows: *e.g.*, *Fifteenth Impression (Third Edition)*. This would indicate that the book had been printed fifteen times, and that in the course of those fifteen impressions it had been revised or altered twice.

#### GENERAL.

THE Academy of Natural Sciences of Philadelphia has received from Miss Anna T. Jeanes a gift of \$20,000, to be invested and known as the Mary Jeanes Museum Fund, the income to be used for general museum purposes. This is a gratifying instance of continued interest in the welfare of the Academy, which has received substantial benefits from members of Miss Jeanes' family during the last forty-five years.

THE conference of astronomers and physicists held at the Yerkes Observatory in 1897 was so successful that it has been decided to hold a conference this year at Harvard College Obser-

vatory. It will be in session on Thursday, August 18th, and the two following days, being thus simultaneous with the meeting of the American Mathematical Society and immediately preceding that of the American Association.

THE fund collected for the Huxley Memorial now amounts to £3,346. The marble statue to be placed in the Natural History Museum is being carried out by Mr. Onslow Ford, and the medal for the Royal College of Science has been completed by Mr. F. Bowcher. About £1,300, which it is hoped will be materially increased, will be left and will be used for a third memorial. The Scientific Memoirs, making a fourth memorial, are, as we have already stated, in course of publication by Messrs. Macmillan & Co.

THE Academy of Natural Sciences of Philadelphia has conferred the Hayden Memorial Geological Award for 1898, consisting of a bronze medal and the interest of the endowment fund on Professor Otto Martin Torell, the Director of the Geological Survey of Sweden, in recognition of his distinguished services to geological science.

HARVARD UNIVERSITY has conferred the degree of Doctor of Laws on the eminent chemist, President James Mason Crafts, of the Massachusetts Institute of Technology.

PROFESSOR O. C. MARSH, of Yale University, has been elected an honorary member of the Geological Society of London.

THE Paris Academy of Sciences has nominated as its first choice M. Lippmann, and as second choice M. Appell, for the vacant place in the membership of the *Bureau des longitudes*.

PROFESSOR H. A. LORENTZ, of Leyden, and M. Émile Picard, of Paris, have been elected foreign members of the London Mathematical Society.

PROFESSOR A. WEISMANN, Professor B. Grassi and M. Hippolyte Lucas have been elected honorary members of the London Entomological Society.

*Nature* announces the death, at the age of seventy-two, of Sir James Nicholas Douglass, F. R. S., late Engineer-in-Chief to the Hon. Corporation of Trinity House. During his ten-



ure of this post he carried out many important engineering works, both at home and abroad, such as the Wolf, Longships, Great and Little Basses, Eddystone, and Muricoy lighthouses, and he effected numerous technical improvements connected with lighthouses and their illuminating apparatus, as well as in buoys and beacons. He was elected a Fellow of the Royal Society in 1883, and retired from his post at the Trinity House in 1892.

THE New York Aquarium has received by the steamship *Orinoco* an interesting collection of tropical fish, sent by Professor Bristol, of New York University, from the Bermudas.

THE tables at the Naples Zoological Station, supported by the University of Cambridge, have been given to Mr. C. H. Hadfield, of Trinity College, and Mr. R. C. Punnett, of Gonville and Caius College.

BUSTS of Skoda and Rokitsansky were unveiled in the Arcades of the University of Vienna at the beginning of June. The *Philadelphia Medical Journal* states that Professor Nothnagel and Professor Weichselbaum delivered the memorial addresses on the occasion for the respective representatives of their specialties. Of Skoda, Nothnagel said: "He was the Lessing of clinical medicine; at once an originator and a critic, of wonderful clearness of comprehension, of untrammelled devotion to truth for its own sake, and of judicial mental acuity. He was the introducer into clinical medicine of exact scientific methods."

A PRIZE of £2,000 is offered by the North of Scotland malt distillers to chemists residing in any country who will devise a successful method for the purification of their waste products. The distillers have been forbidden to empty these into the streams.

THE United States Civil Service Commission announces that it is desired to establish an eligible register from which a selection may be made to fill the grade of Assistant, Division of Entomology, Department of Agriculture, at a salary of \$1,000 per annum. No educational test will be given, but applicants will be graded upon the subjects of drawing of insects and wood engraving of insects, together with their technical knowledge of the order Heteroptera. Ap-

plicants will be required to furnish samples of their work covered by the first two subjects, and they will submit on a special form prepared by the Commission a statement showing their technical knowledge of the last-named subject. They will also be required to submit a statement in the form of an affidavit that the work has been performed by them without aid from any one. Application must be made not later than July 21st.

IN connection with a notice of Professor Hale's address on 'The Function of Large Telescopes' (SCIENCE, May 13, 1898) *Nature* quotes from the *Observer* the statement that in the number of refractors exceeding 13.4 inches America comes first, France second, England third and Germany fourth.

THE yacht *Windward* sailed from New York on July 2d and will be met by Lieutenant Peary at Cape Breton. The steamship *Hope* with supplies and coal had previously sailed, and will join the *Windward* at North Baffin's Bay.

THE Norwegian Geographical Society gave a banquet on June 21st to the expedition under Captain Sverdrup, which was on the point of leaving for exploration along the north and north-west coast of Greenland. The *London Times* says that several of the Norwegian Ministers were present, as well as the Presidents of the two Houses of Parliament, and Dr. Nansen and other distinguished men. Professor Mohn, the eminent meteorologist, made an interesting speech in proposing success to the expedition. Captain Sverdrup, in his reply, said that he would do his best, with the aid of his able staff, to bring back varied and valuable scientific results and to put some color on the great white space to the north of Greenland. The speech of the evening was, of course, that by Dr. Nansen, who was listened to with intense interest as he dwelt on the strange feelings which animated him on seeing the *Fram* go out once more under his trusty and brave comrade Sverdrup. He dwelt on Sverdrup's gallant exploits, both on the expedition across Greenland and on that in the *Fram*, in the success of which Sverdrup had so large a share. The *Fram* was now better fitted out in every way



than it had been on the last memorable drift in the great Arctic current, and he was confident that his friend and comrade would bring back great results.

MR. A. P. LOW, of the Geological Survey of the Dominion of Canada, has gone to Labrador, where he will remain for eighteen months, in order to study the geological formations and make a map of the region.

As we have recently referred on several occasions to the conferring of the Prussian order *Pour le mérite*, it may be well to quote from *Nature* the following details regarding this order: Founded by Frederick the Great, it was at first given for military service only, but its statutes were remodeled in 1842 by King Frederick William IV., and the class 'für Wissenschaften und Künste' was instituted. The German knights of this class, with whom the election into the Order practically rests, are limited to thirty in number, and at present are: A. Menzel, Chancellor; T. Mommsen, Vice-Chancellor; the other members in the order of election being, in the Section of Science: R. W. Bunsen, Max Müller, E. Zeller, T. Noeldeke, J. V. du Vernois, A. Auwers, E. Pfüger, H. Vogel, A. v. Baeyer, O. Fürst v. Bismarck, F. Kohlrausch, H. Grimm, H. Brunner, A. v. Kölliker, H. Usener, W. Hittorf, A. Weber, C. Neumann and Schwendener. In the Section of Art: L. Knaus, A. Achenbach, J. Schilling, R. Begas, F. Schaper, E. v. Gebhardt, H. Ende and A. Hildebrand. The foreign knights, limited to the same number, are, in the Section of Science: O. v. Boethlingk, C. Hermite, Sir G. G. Stokes, N. A. E. v. Nordenskjöld, M. Berthelot, O. v. Struve, Lord Kelvin, Lord Lister, V. Jagie, P. Villari, H. Kern, J. G. Agardh, M. J. de Goeje, G. V. Schiaparelli, F. Imhoof-Blumer, J. H. van't Hoff, A. O. Kowalevsky, W. Stubbs (Bishop of Oxford), O. Montelius, Sir John Murray and Sir W. H. Flower. In the Section of Art: L. Alma Tadema, G. Verdi, G. Monteverde, E. Wauters, L. Passini and F. Pradilla.

THE French government has appointed the following as delegates to the International Congress of Zoology: M. A. Milne-Edwards, membre de l'Institut, Directeur du Muséum d'Histoire

Naturelle de Paris, Vice-Président de la Section des Sciences du Comité des Travaux Historiques et Scientifiques, Président de la Délégation; M. Barrois, Professeur à la Faculté mixte de Médecine et de Pharmacie de l'Université de Lille; M. Bigot, Professeur à la Faculté des Sciences de l'Université de Clermont; M. R. Blanchard, membre de l'Académie de Médecine, Professeur à la Faculté de Médecine de l'Université de Paris, Sec. Général de la Société Zool. de France; M. A. Caullery, Maître de Conférences à la Faculté des Sciences de l'Université de Lyon; M. Y. Delage, Professeur à la Faculté des Sciences de l'Université de Paris; M. Filhol, membre de l'Institut, Professeur au Muséum d'Histoire Naturelle de Paris; M. Girod, Professeur à la Faculté des Sciences de l'Université de Clermont; M. le Baron J. de Guerne, membre de la Société Zool. de France, Sec. Général de la Société d'Acclimatation; M. Joubin, Professeur à la Faculté des Sciences de l'Université de Rennes; M. Lambert, Agrégé près la Faculté de Médecine de l'Université de Nancy; Dr. Lartet, Doyen de la Faculté mixte de Médecine et de Pharmacie de l'Université de Lyon, Professeur à cette Faculté; M. Edmond Perrier, membre de l'Institut, Professeur au Muséum d'Histoire Naturelle de Paris; M. Roule, Professeur à la Faculté des Sciences de l'Université de Toulouse; M. Schlumberger, membre de la Société Zool. de France; M. Léon Vaillant, Professeur au Muséum d'Histoire Naturelle de Paris, Sec. de la Section des Sciences du Comité des Travaux Historiques et Scientifiques de la Société Zool. de France; M. Ch. Janet, Vice-Président de la Société Zool. de France.

IN the Museum of the Scarborough Philosophical and Archæological Society, says *Natural Science*, Mr. C. D. Head has been replacing the old and ruinous collection of birds by cases displaying them, so far as possible, in their natural habitat, with their nests and eggs, when these can be obtained. An improvement has also been made in the cases for the fossils. The Society records the capture of two badgers—one at Cloughton, the other near Folkton. The record of local birds has been placed upon a more satisfactory basis, every item contained in the list being thoroughly authenticated. Fish,

both sea and fresh-water, also are being studied; Mr. F. Grant records the occurrence of various species not hitherto observed. Considerable attention is also paid by members of the Society to the Invertebrata of various Classes, though naturally the land and fresh-water Mollusca and the Lepidoptera come in for the giant's share. The geologists have paid attention to the exposures during the making of the Marine Drive, but not many fossils have yet been found.

WE learn from the *Experiment Station Record* that Congress has continued and increased the appropriation for investigations in Alaska with reference to the establishment of agricultural experiment stations there. Professor C. C. Georgeson, formerly professor of agriculture in the Kausas Agricultural College, has been assigned to this office as special agent in charge of the Alaska investigations. He will make his headquarters at Sitka, and will institute experiments with cereals, vegetables and other crops at a number of places in that vicinity. He will also visit Kadiak Island, Cook Inlet and other points north of Sitka, with reference to the selection of land for experimental purposes and the institution of experiments with the cooperation of residents of Alaska interested in the development of its agriculture. Questions relating to the temperature, moisture and drainage of the soil, the curing and storage of forage plants, and the shelter and care of animals will receive early attention. The Weather Bureau will also establish a special climatological service in Alaska during the present season. A meteorological station will be located at Sitka and instruments will be furnished to voluntary observers in different parts of Alaska. In this way observations will be regularly made, which it is hoped will be of much service in the solution of agricultural problems, as well as of great importance to other interests in Alaska.

LUMMER AND BRODHUN, the extreme accuracy of whose work in photometric investigations is well known, have studied Talbot's Law by methods so exact that the mean error of observation is at most  $\frac{1}{2}$  %, and find that the departures from the law fall well within that limit. They have before been found to fall

within the limit of error, but when that limit was three to eight per cent. the law could not well be considered to be absolutely confirmed. The present confirmation holds only for sectors from twenty-five to ninety degrees in breadth; when the sectors are very narrow, diffraction from the edges has to be taken account of. As rotating sectors present the best method for securing a measurable change of brightness upon the photometric screen (it is easily combined with any apparatus, can be introduced anywhere in the course of the light rays, does not change the character of the light, so that it is not necessary to attend to conditions of polarization, and diminishes all light rays equally and in accordance with a simple law), the authors have devised a very exact apparatus by which the size of the sectors can be continuously varied during rotation; this has been in use for some time, and is found to work well.

MR. NEWSTEAD, Curator of Chester Museum, England, who has made an exhaustive study of the San José scale pest, has been lecturing on the subject before the Zoological Section of the Chester Society of Natural Science. According to the *London Times* Mr. Newstead, who has had an interview with Mr. Long, Minister of Agriculture, and his advisers at the Board, said he had suggested that the government should engage a staff of trained workers to detect suspicious imports of fruit and submit them for expert examination. The origin of the American fruit pest scare was due to the action of Germany in March of the present year. That country had passed a law protecting itself from the importation of infested fruit. The oyster scale which infested some fruit trees resembled the San José so closely that it was impossible to distinguish one from the other except by microscopical examination. If a tree was infested by the insects a sort of scurfy material would come away, which was really their wax-like scales. The actual size of the insect was a millimeter in length, which meant that it would not cover the head of an ordinary pin. Mr. Newstead explained the life-history of the insect, showing that after two days of activity in the larval stage it became an inert fixed mass, living in the same place for the rest of its life

and sustaining itself on the tree juice, which in time stunted and diseased the tree. During one season a single female insect was capable of producing 500 or 600 young, and in some parts of America there were five or six broodings. Its presence had been recorded in three places out of America—Australia, Chile, and one of the Western Islands. He did not think it would thrive in England, but it was very desirable to prevent its introduction.

THE University of London has excluded mental and moral science from the list of subjects that may be offered for the University's degrees in science. A memorial protesting against this action has been presented, in the course of which it is said: "By its attitude in the past the University of London has not a little encouraged the more strictly scientific study of psychology, both as a science of observation and in its relation to physiology. Among students of physical science a certain number have a distinct taste for philosophical study, and it is desirable to encourage such students with a view to the development both of scientific methodology and of psychology on its experimental and physiological side. The student who approaches the mental sciences from the literary side deals with them naturally in a different spirit. For the development of the subject in its relation to the general body of science it is necessary that it should be studied by some who are familiar with the principles and methods of physical science. At the present time much scientific labor of this kind is being spent on psychological inquiry in other countries. In most of the principal universities of Continental Europe and America psychological laboratories have been founded at considerable expense, and foreign journals are published for the express purpose of recording experimental work in psychology. In this country efforts are being made to develop a similar line of study. The University of Cambridge has recently appointed a lecturer in experimental psychology, and a laboratory has been opened this session at University College. To all such efforts this sudden *volte face* of your University is a serious blow. We venture, therefore, respectfully to express our hope that you will readmit mental and moral science into the schedule for the sci-

ence degrees, with such modifications, should they be deemed necessary, as may serve to accentuate the scientific sense in which the subject should be treated for the purpose of a degree in science." Amongst those who have signed the memorial are the Master of Balliol, Professor Henry Sidgwick, Mr. R. B. Haldane, Q.C., M.P., Professor Burdon Sanderson, Professor William Ramsay, Professor F. Y. Edgeworth, Mr. Francis Galton, Dr. A. Robertson, Principal of King's College, Professor Sully, Mrs. Sophie Bryant, D.Sc., Mr. C. Lloyd Morgan, Professor Foxwell, Mr. Bernard Bosanquet and Professor Oliver Lodge.

THE official opening by Sir Owen Tudor Burne of the exhibition of acetylene gas apparatus and production at the Imperial Institute took place on Wednesday, June 15th, when a considerable number of generators of various types were to be seen in operation. We learn from the *London Times* that these are arranged in a building in the southwest quadrangle, and each set of apparatus is connected by its own separate service pipe to its own gaselier in one of the galleries so as to enable the public to judge of the quality and steadiness of the light produced by each installation. A number of portable generators and self-contained lamps are also on view, together with several forms of bicycle lamp. All the apparatus, before being admitted to the exhibition, had to fulfil certain conditions of safety deemed necessary by a committee of scientific men appointed by the Society of Arts and including, among others, Sir Frederick Bramwell, Professor James Dewar, Mr. Harry Jones, Professor Vivian B. Lewes and Mr. Boverton Redwood. This committee formulated certain rules to be observed in the construction of all generators, and the London County Council gave it permission to use a portion of their premises at 211 Harrow-road for the purpose of carrying out the necessary tests. While the committee in this way sought to ensure that none but safe types of machine were shown at the Institute, it did not touch the question of the efficiency of the various designs. This is to be tested during the exhibition. It is intended to keep a daily record of all apparatus at work, in accordance with the directions laid down by the committee,



and to issue a report on the results of the working. The exhibition will remain open till August 15th.

THE acetylene exhibition, which was originally planned for Cannstadt, near Stuttgart, took place at Berlin on the Kurfürstendamm, says the *Scientific American*, in connection with an acetylene conference. Acetylene generators were exhibited by thirty firms, but most of them were not shown in operation, owing to the strict regulations enforced by the police. The generators in action had each to be shown in a special compartment not accessible to the general public, behind a strong wall. This was not in itself calculated to inspire the citizens of Berlin with a very happy idea of the safety of the new illuminant. Progress could be recognized in the exhibits, but as yet there does not appear to be any special type which is the favorite. Acetylene purifiers proved to be necessary adjuncts. Among the impurities of acetylene less thought of in general is phosphureted hydrogen. In spite of purifying, the hall every evening was foggy with the fine dust of the phosphoric acid. Next year the meeting will be held at Budapest.

It is, perhaps, not generally known, says the *British Medical Journal*, that Professor Charles Richet, who delivered an address on The Work of Pasteur and the Modern Conception of Medicine at the annual meeting in Montreal, is a novelist and a dramatic author as well as a physiologist of the first rank. Under the pseudonym of 'Charles Epheyre' he has gained a considerable reputation in contemporary French literature. His most successful novel, *La Douleur des Autres*, was published in 1896, having first appeared serially as a *feuilleton* in the *Indépendance Belge*. Among his other works of fiction may be mentioned *Sœur Marthe*, the plot of which turns on the love of a physician for a hypnotizable patient; *Amour de Garnison*, *Bonne et Mauvaise Étoile*, *A la Recherche de la Gloire*, and *Le Microbe et le Mirosourus*. 'Charles Epheyre's' last play, *Judith*, written in collaboration with M. Octave Houdaille, was produced at the Bodinière Theatre on March 28, 1898. Professor Richet is also the author of *L'Homme et l'Intelligence* and other works on

psychology, and the Editor of the *Revue Scientifique*.

At the Royal Geographical Society, on April 27th, a paper was read by Dr. Sambon on 'Acclimatization of the white man in tropical lands.' Within recent times, he said, according to the report in the *London Times*, sanitation had wrought wonderful changes in the healthiness of all tropical countries. They had been considered unfit for the permanent settlement of white men on account of their climate, or, to be more correct, on account of their heat, because the word climate had been used as synonymous with heat. Heat was supposed to induce deterioration and diseases, such as anæmia, liver abscess and sunstroke. But anæmia was not due to heat, being in the tropics a symptom common to several parasitic diseases. Liver abscess was likewise of parasitic origin and sunstroke was a microbic disease, however paradoxical the statement might appear, on account of the mistaken etiology perpetuated by an erroneous nomenclature. As for deterioration, it was far more alarming in the overcrowded cities of the Old World than in tropical colonies. The geographical distribution of tropical diseases was of the greatest importance in the study of acclimatization. Diseases being due to living organisms that had their peculiar dissemination like all other forms of life. This distribution was likewise determined by a variety of circumstances, among which meteorological conditions were certainly important, but association and competition more so. Under proper management European children did very well in tropical colonies, in the most unhealthy of which infant mortality was lower than in some districts of Europe. The belief, again, that white men could not labor in the tropics was disproved by facts. That man was capable of adaptation to a new climate was shown by the fact that he had constantly moved from one region to another. If attempts at colonization in the past had often been unsuccessful and always cost immense sacrifice in lives and money, it was because they had been made in complete ignorance of the conditions essential to success. Acclimatization was a mere question of hygiene, and what was needed above all was a complete



knowledge of tropical diseases. A discussion followed.

#### UNIVERSITY AND EDUCATIONAL NEWS.

THE University of London Commission Bill has passed the second reading in the British House of Commons without a division.

CAMBRIDGE UNIVERSITY has received a bequest of £10,000 for the foundation of a scholarship or prizes.

THE Wawepex Society has given \$200 for a scholarship in biology at the Coldspring Laboratory of Biology, to be filled by a graduate student of Columbia University. Mr. F. B. Sumner has received the appointment.

THE chair of botany in the University of Wisconsin, vacant by the removal of Professor Charles R. Barnes to the University of Wisconsin, has been filled by the election of Dr. R. A. Harper, of Lake Forest University.

DR. ALEX. HILL, master of Downing College and an eminent physiologist, has been re-elected Vice-Chancellor of Cambridge University for the ensuing academical year.

MR. R. PENDLEBURY and Mr. A. E. H. Love, F.R.S., fellows and lecturers in St. John's College, have been appointed University lecturers in mathematics.

PRINCIPAL CAIRD will on August 1st retire from the principalship of Glasgow University.

MISS GERTRUDE HALLEY has been appointed one of the demonstrators in anatomy in Melbourne University.

M. P.-M. LABATUT has been given charge of the instruction of physics and chemistry in the medical school of Grenoble.

#### SCIENTIFIC LITERATURE.

*La Mathématique; philosophie, enseignement.* Par C.-A. LAISANT, répétiteur à l'école polytechnique, docteur ès sciences. Paris, George Carré et C. Naud. 1898. Pp. 292.

The above work consists of three parts: the philosophy of pure mathematics, the philosophy of applied mathematics, and the teaching of mathematics. The first part is subdivided into the following chapters: Mathematics and its

Divisions, Arithmetic and Arithmology, Algebra, Infinitesimal Calculus, Theory of Functions, Geometry, Analytical Geometry, Rational Mechanics. The second part is divided into General Considerations, Application of the Calculus, Application of Geometry, Application of Mechanics, and the third into General View of the Teaching of Mathematics, Teaching of Arithmetic, Teaching of Algebra and the higher Calculus, Teaching of Geometry, Teaching of Analytical Geometry, Teaching of Mechanics, the Hierarchy of Education.

In an introductory chapter M. Laisant sets forth the aim of the book. He says that he does not write for those who are deeply versed in mathematical science, nor those who are ignorant of it, but for a middle class, namely, those who are studying mathematics or have studied it and whose knowledge and interest are kept alive by teaching it or by being engaged in work requiring its application. It may be said, however, that whatever is written on the philosophy of mathematics by so eminent a master of geometric algebra and distinguished investigator of the hyperbolic functions cannot fail to be of interest to the professional mathematician; and even the mere seeker after culture will find in this volume many things to arouse his interest in the most perfect of all the sciences.

In traversing the domain above described the author discusses many questions of scientific and educational interest; in this notice there is only room to mention a few. One of the first points he makes is that it is not correct to speak of the mathematical sciences, as they all aid one another, give mutual support, and in certain parts blend together; there is but one vast science, which no one can flatter himself to master completely, for its conquests are infinite in nature.

M. Laisant does not pretend to be a professional philosopher, but he has read the works of Leibnitz, Descartes, Pascal, D'Alembert, Diderot, Condorcet, Comte, each of whom was a philosopher, and likewise left a brilliant record in mathematical science; in this volume we have the digested results of his reading and reflection. Work of the character described is the most valuable kind of philosophy, and very rare in these times, for the saying of Leibnitz

is as true now as ever: "Sans les mathématiques ou ne pènètre point au fond de la philosophie; sans la philosophie on ne pènètre point au fond des mathématiques; sans les deux, on ne pènètre au fond de rien."

The author bases the plan of the volume on an opposition between pure mathematics and applied mathematics. It is pure mathematics which furnishes us with infallible formulas and deductions; it is applied mathematics which completes the work by showing the necessary existence of errors. The distinction made is largely that between rational and empirical laws in physics. It is not that the one is independent of experience and the other dependent on it; for both are based on experience (p. 10). Why the formulas of the one are infallible, while those of the other are not, is not made very clear.

The author is not satisfied with any of the current definitions of mathematics, but prefers to describe it by means of its object. The essential object of all science, according to M. Laisant, is the study of the phenomena presented by the external world; and the mathematical treatment of these phenomena consists of three stages: forming the equations, solving the equations, interpreting the results.

As regards the importance of mathematical science, the author quotes the saying of Kant: "A natural science is a science only so far as it is mathematical," and that other saying attributed to Napoleon the First: "The advancement and progress of mathematics are bound up with the prosperity of the State." According to M. Laisant it is the most marvelous instrument created by the genius of man to aid in the discovery of the truth.

At page 30 the author takes the ratio or relative view of algebraic quantity and is led to look upon multiplication as the formation of a number (the product) which has to the multiplicand the same ratio as that which the multiplier has to unity. While this may be sufficient for elementary arithmetic, it does not satisfy the calculus of the mathematical physicist, for with him a symbol stands for a magnitude of some kind, not for its ratio to some supposed unit.

The author criticises in vigorous terms the

procedure adopted by some of giving mathematics a definitional or ideal basis. It is marching in the direction opposite to progress, and is a revival of the attitude of the sophist. Algebra is not one, but several, because the properties of the quantities which it treats are different in their nature. Thus the rules of the method of quaternions differ from those of algebra not by arbitrary definition, but because the geometry of space demands it. At another place the author suggests that the method of quaternions when more fully developed is certain to modify and advance the theory of functions.

The author says that the fundamental error of the ancient geometers was that they did not recognize the experimental element which is at the base of geometry; when it is recognized, the non-Euclidean geometry becomes a logical possibility.

What is said on the teaching of mathematics refers to France, but much of it is valid everywhere. In the domain of primary mathematics the pupil ought to be interested, encouraged to make research, be given the feeling—the illusion, if you will—that he is discovering for himself what he is being taught. This demands in the first place a teacher of a high order, and in the second place that the class be small and homogeneous. When the class become a flock and the teacher a shepherd's dog, no progress is possible. The fundamental principles ought to be singled out and exhibited in all their relations, and their meaning made clear by frequent applications. Memory ought to play a very subordinate part; it is the understanding which ought to be exercised. In the domain of the more advanced instruction he does not favor the study of a text-book, still less dictated lessons. He recommends notes taken by the pupil of oral lessons. In the highest domain he recommends the taking of notes, supplemented by a text-book.

For the first introduction to arithmetic he recommends a rigorously experimental method; to have the child to make his own notions in the presence of realities which he can touch and see, to demonstrate nothing, and to make the instruction have the appearance of play rather than of work. In this way a firm

foundation is laid for the teaching of the principles and rules.

In the teaching of algebra he would make plain the theory of imaginaries, when the extraction of the square root comes up; and would introduce an exposition of geometric quantity before taking up the equation of the second degree. He predicts that the day when the geometric calculus will be introduced in the regular course of instruction is not far off. In the concluding chapter he deploras the too great centralization of mathematics in Paris to the injury of the rest of France.

In conclusion we recommend the volume to the notice of every live mathematician, and to every one interested in the nature of human knowledge.

ALEXANDER MACFARLANE.

*Elements of Comparative Zoology.* By J. S. KINGSLEY, S.D., Professor of Zoology in Tufts College. New York, Henry Holt & Co. 1897.

This book of 357 pages embodies an attempt to combine the text-book proper with the laboratory manual in such proportions as to meet the demand of the beginner. It is contended in the preface that "a knowledge of isolated facts, no matter how extensive, is of little value in education, excepting as the powers of observation are trained in ascertaining those facts." In accordance with this idea, the author lays stress upon the more obvious features of the types considered, and seeks to lead the student to an intelligent appreciation of the significance of those features in studies under the title of 'Comparisons.' For example, a bony and a cartilaginous fish are studied separately, and then the facts acquired by the student are correlated by a series of questions which require a careful comparison. In this way twenty-five types are studied and compared, the types representing all the main divisions of the animal kingdom, and being chosen from the most readily accessible materials.

The text of the work is based upon the systematic relations and discusses the orders seriatim.

There is one detail of arrangement, however, which will not appear to everybody to be entirely happy. In the discussion of the fishes

the Selachii and Teleosts are treated at some length, and then follows the part bearing upon Pisces. When one comes to the sub-classes he is referred back to Selachii and Teleosts. This may prove somewhat confusing, although the motive is evidently to emphasize the groups of which types have been studied.

There are numerous illustrations and diagrams, the latter in many cases being particularly suggestive.

The part devoted to the laboratory work is arranged in the form of simple directions for dissection and questions to lead the student to as independent a method as possible. The criticism that will be forthcoming will be that the laboratory work is meager—that students, even in the high school, frequently want to know more than the laboratory guide leads them to. This, however, is a minor criticism, since the teacher, if up to the mark, can supplement the work according to his judgment.

The introduction contains suggestions in regard to the carrying on of laboratory work; apparatus, which is reduced to a minimum as to both quantity and simplicity; materials for dissection, and reference books.

The whole is a small, handy volume, neatly bound and well printed on good paper.

F. E. LLOYD.

*The Phytogeography of Nebraska.* 1. General Survey, by ROSCOE POUND, Ph.D., Director of the Botanical Survey of Nebraska, and FREDERIC E. CLEMENTS, A.M., Assistant Instructor in Botany in the University of Nebraska. Lincoln, Neb. 1898. 8vo., 329 pp., with four maps. Presented by the authors to the Faculty of the University of Nebraska as a thesis for the degree of Doctor of Philosophy.

From the preface we learn that this work is the result of nearly five years of active study of the floral covering of Nebraska, carried on by the members of the Botanical Seminar in the Botanical Survey of the State. The systematic study of the vegetation of Nebraska was begun by Dr. Bessey in 1884, and has since been carried on by him and his students, all previous collecting having been more or less desultory and unreliable. The Botanical Survey was or-



ganized in 1892, and its work has been directed to the collecting of specimens and observations for a series of reports in which the floral covering of the State should be treated from the phytogeographical standpoint and for a series of monographs of the flora of Nebraska. A beginning has been made by the publication of three parts of the flora of the State, and the present work is the first part of the first series. The authors realize that so much yet remains to be done in many directions that a complete phytogeography of the State will be impossible for many years to come, but the work of the survey has progressed far enough to enable them to present the general facts of its phytogeography in an adequate manner and to deal with details in many of the more important subjects.

The writings of the German phytogeographers have been the chief source of inspiration, especially the *Plant Geography of Germany*, by Dr. Oscar Drude. It is only in recent years that this subject has become a distinct department of botanical knowledge, and with the exception of certain observations conducted by Professor MacMillan in Minnesota, this is the first attempt to conduct a botanical survey of any State in this manner. It is, therefore, of special interest and deserving of more than passing mention, as even a hasty review of the table of contents will be convincing proof of the broad scope of this work and shows the amount of preliminary preparation which it represents.

In the introduction the authors give a brief outline of the scope of their subject, and state that much of their terminology is new, having been translated from the German or newly coined to meet special necessities. The history of the botanical exploration of Nebraska is briefly given and a list of works consulted fills several pages, including many local lists and contributions to the State flora by Dr. Bessey and his students.

The subject is treated in five chapters, the first dealing with the physiography, geology and meteorology of the State. There is little rock exposed, the soil being of unusual depth, but in the southeastern part of the State the geological formations are Carboniferous, while

the rest is Cretaceous and Tertiary. The climate is extremely hot in summer and mild in winter. Meteorological tables are given to show the temperature and rainfall for 1896.

The second chapter deals with statistics of regional limitations, showing that the four regions which occur in the State are the wooded bluff and meadow land region, the prairie region, the sand-hill region and the foot-hill region, and that of all these the proportions occurring in the State are only a small part of the same regions in adjacent States. Tables of species peculiar to each region are given. In the third chapter the different forms of vegetation are considered under the heading of woody plants and herbs, and the various habits and devices of each for protection and reproduction are considered in relation to their place of growth. Size, duration, means of reproduction and dissemination and protective devices are all important factors in the distribution of plants. According to the last report of the Botanical Survey there are 3,196 species in the flora of the State, of which 1,717 are cryptogams, the myxomycetes not being included. The number of trees is 58; shrubs, 33; bushes, 32; climbers, 13. A comparison of the flora of the State shows that 90 per cent. of the plants are herbaceous, there being but little forest. In New Jersey the percentage is 86, in Spain 83, and Germany 89. Herbs are less stable in their distribution than woody plants and their migrations are frequent. The herbaceous plants are considered in groups as perennials, biennials, annuals, aquatics, parasites and thallophytes. Of the perennial herbs, those forming rosettes include 27 species, those forming mats 18, succulent plants adapted to high alpine or desert regions number 10 species; creepers and climbers include 35 species; turf-builders include 44 sod grasses and 49 bunch grasses; of plants with perennial rootstocks the number is 472, comprising the largest number of herbaceous plants, not including 37 bulbous or tuberous species and 16 ferns. Of biennial herbs the flora includes 59 species and annuals 197. Water plants are not as common, there being 12 floating plants, 31 submerged and 45 amphibious species in the State, and of parasitic species 14, exclusive of 3 species of saprophytes.



Of the Thallophytes the mosses are few, as only 50 species are known to occur in the State and 16 liverworts; lichens number 157. Of the Fungi, those growing on wood number 266, those on living plants 445, those on decaying matter 75, aquatic parasites on fishes, etc., 18, and on insects 9. The Algae number 438. The chapter concludes with a discussion of the various biological characters, including protective devices, periods of flowering, seed production and dissemination.

The fourth chapter treats of the relations of the natural group of plants dividing them into six groups according to habitat, and giving tables for each of the natural families showing the numbers of species in each inhabiting the different regions. This represents an immense amount of local work, and it is impossible to give any adequate conception of the careful tabulation which it necessitates. The last chapter treats of the plant formations showing that the floral covering of the earth is not homogeneous, but presents great differences in the kinds and abundance of species as well as variations in the size, habit and habitat of individuals. Such diversities are the direct result of physical and climatic conditions peculiar to more or less restricted areas, hence the vegetation of the earth's surface is arranged into groups of definite constitution and more or less definite limits, known as plant formations. Such formations are invariably complex and more or less difficult to determine, yet they represent a biological community resulting from the forces induced by physiographical and meteorological phenomena, and may be defined as a piece of the floral covering, the extent of which is determined by a characteristic association of vegetable organism forming a stretch of land whose limits are biological and not physiographical, but often having the delimitation of some natural boundary. The topics are treated under the following heads: Forest, Meadow, Prairie, Sand hill, Foot hill, Salt marsh, Water plant, Culture and Waste formations. This chapter constitutes perhaps the most readable portion of the book, summing up the results and effects of all previous observations.

In the appendix certain corrections are made in elevations of various points, and the nomen-

clature is made to correspond with that of Britton and Brown's illustrated Flora. The four maps show the political boundaries of the State, its topographical characters, the river systems and the natural regions. The index is extensive, including both topics and species.

It will thus be seen that this work indicates the progress of biological studies in recent years, and the long distance from which it is removed from mere lists and catalogues, yet at the same time it emphasizes the importance of thorough systematic and morphological studies, and proves the necessity of broad and correct training in order to be able to accomplish such a task creditably. That this has been so ably done not only reflects credit on its authors, but also on the faculty under whose guidance the work has been accomplished.

ELIZABETH G. BRITTON.

#### SCIENTIFIC JOURNALS.

The *American Naturalist* for May opens with a paper on the origin of the mammalia by Professor Henry F. Osborn, presented first at the Toronto meeting of the British Association. The paper especially considers the evidence supporting the hypothesis that the mammals spring from the theriodont reptiles, knowledge of which has been so greatly increased by Professor Seelye's explorations in the Karoo beds of South Africa. The third chapter of the treatise, on the wings of insects, by Professor J. H. Comstock and Mr. J. G. Needham, treats of the Diptera. Mr. O. P. Hay writes on the classification of Amoid and Lepisosteoid fishes.

THE July number of *Appleton's Popular Science Monthly* opens with the first of a series of articles on the evolution of colonies, by Mr. James Collier. Mr. E. J. Prindle contributes an elaborately illustrated article on the methods used by the Weather Bureau in forecasting the weather. Professor S. W. Williston writes on saber-toothed cats. The frontispiece is a Portrait of Maria Agnesi, who was in 1750 nominated professor of mathematics in the University of Bologna.

THE *American Anthropologist* for June contains the following articles: An Ancient Human Effigy Vase from Arizona, by J. Walter

Fewkes; Use of Rubber Bags in Gauging Cranial Capacity, by Washington Matthews; Ojibwa Feather Symbolism, by W J McGee. The Girl and the Dogs—An Eskimo Folktale with Comments, by Signe Rink.

THE July *Monist* opens with an article by Professor C. Lloyd Morgan on 'The Philosophy of Evolution,' which seeks to reconcile metaphysics with science. Professor Jacques Loeb has a brief discussion of 'Assimilation and Heredity,' maintaining that, since any theory of heredity must be based upon the mechanics of assimilation, we are consequently forced to supplement our purely morphological hypothesis of heredity by a chemical theory. Dr. Paul Topinard devotes some forty odd pages to the treatment of the 'Social Problem,' which he reviews in the light of natural history, anthropology and sociology proper. In 'Gnosticism in Its Relation to Christianity,' Dr. Paul Carus seeks to show that gnosticism, far from having been a heretical Christian sect was a general religious movement of pre-Christian times, and that Christianity sprang from it and survived it by the law of the survival of the fittest.

#### SOCIETIES AND ACADEMIES.

ACADEMY OF NATURAL SCIENCES OF PHILADELPHIA, JUNE 21.

MR. LEWIS WOOLMAN described a series of well-borings from Rock Hall, Maryland, indicating the depth at which forty-one forms of diatoms occur. The deposit resembles that for 80 to 100 feet at Wildwood, Maryland. He regarded the deposit as much more recent than miocene. A small bed of the latter is placed between it and the Eocene. There is a considerable mixture of fresh-water diatoms with the marine forms.

MR. D. S. HOLMAN described the fission of three forms of infusorians generated in putrifactive solution.

MR. PHILIP P. CALVERT recounted his recent studies of dragon-flies from tropical America and dwelt on his mode of determining averages of variations in extensive groups. Much the largest proportion of such variation is atavistic, illustrations being given from the genera described.

A paper entitled 'A New Chipmunk from Northeastern China,' by Gerrit S. Miller, Jr., was presented for publication.

EDW. J. NOLAN,  
*Recording Secretary.*

TORREY BOTANICAL CLUB, APRIL 27, 1898.

THE first paper, by Mr. Tracy E. Hazen, was entitled 'Notes on the Life History of *Hæmatococcus* and other Fresh-water Algae.' He exhibited a dried specimen of *Hæmatococcus* from Vermont, consisting of a dull red incrustation on rock, from which some of his own cultures had been made. The paper, which will soon be published, described the stages of its life history, and was illustrated by colored drawings. Discussions by Professor Lloyd, Dr. Townsend, Dr. Britton and others followed. The Secretary referred to a gathering of Red Snow made at the Crimson Cliffs of North Greenland by the Peary party two years ago, which exhibits a much more brilliant red than the *Hæmatococcus* of our own neighborhood.

The second paper, by Mrs. Elizabeth G. Britton, was entitled 'An account of the Mosses collected by Mr. Pierre Jay in Peru and Bolivia in 1893.' She exhibited about 60 sheets of these mosses, the specimens shown forming, however, only a small part of the entire collection, which include many species of tropical American genera like *Hookeria* and *Meteorium*, not yet determined. The Bolivian specimens were collected in June and July near La Paz and Yungus, and are largely species of high altitudes and exposed localities. The Peruvian specimens were collected in the vicinity of Cuzco and the tributaries of the Madre de Dois, and are mostly forest species, including showy *Phyllogonium* and *Porotrichum* and various species of *Entodon* and *Rhizogonium*. The collection promises to be very interesting and will be compared with Dr. Rusby's collections of 1885 and M. Germain's, both of which have recently been enumerated and described by Dr. C. Müller in his *Prodromus of the Mosses of Bolivia in the Nuovo Giornale Botanico Italiano for 1897.*

EDWARD S. BURGESS,  
*Secretary.*

# SCIENCE

EDITORIAL COMMITTEE: S. NEWCOMB, Mathematics; R. S. WOODWARD, Mechanics; E. C. PICKERING Astronomy; T. C. MENDENHALL, Physics; R. H. THURSTON, Engineering; IRA REMSEN, Chemistry; J. LE CONTE, Geology; W. M. DAVIS, Physiography; O. C. MARSH, Paleontology; W. K. BROOKS, C. HART MERRIAM, Zoology; S. H. SCUDDER, Entomology; C. E. BESSEY, N. L. BRITTON, Botany; HENRY F. OSBORN, General Biology; C. S. MINOT, Embryology, Histology; H. P. BOWDITCH, Physiology; J. S. BILLINGS, Hygiene; J. MCKEEN CATTELL, Psychology; DANIEL G. BRINTON, J. W. POWELL, Anthropology.

FRIDAY, JULY 15, 1898.

THE AMERICAN ASSOCIATION FOR THE  
ADVANCEMENT OF SCIENCE.

## CONTENTS:

<i>The American Association for the Advancement of Science</i> .....	57
<i>The Breeding of Animals at Woods Hole during the Month of May, 1898</i> : PROFESSOR HEEMON C. BUMPUS.....	58
<i>Natural History Museums (II.)</i> : L. P. GRATA-CAP.....	61
<i>George Baur</i> : O. P. HAY.....	68
<i>Current Notes on Anthropology</i> :—	
<i>The Latest Asiatic-American Affinity; The Study of Local Ethnography; Women as Anthropological Students; Stone Pendants</i> : PROFESSOR D. G. BRINTON.....	71
<i>Scientific Notes and News</i> :—	
<i>Scientific Societies Affiliated with the American Association for the Advancement of Science; The Coral-boring Expedition to Funafuti; Dietary Studies; Science and Industrial Supremacy; General</i> .....	72
<i>University and Educational News</i> :—	
<i>Report of the Commissioner of Education for the Year 1896-97; General</i> .....	78
<i>Scientific Literature</i> :—	
<i>Mine's Electro-Chimie and Electro-Metallurgie</i> : PROFESSOR EDGAR F. SMITH. <i>Ladd's Quantitative Chemical Analysis</i> : J. E. G. Haddon on the Study of Man: PROFESSOR D. G. BRINTON..	80
<i>Scientific Journals</i> .....	82
<i>Societies and Academies</i> :—	
<i>The Torrey Botanical Club</i> : E. S. BURGESS.	
<i>The Engelmann Botanical Club</i> : J. B. S. NOR-TON.....	83
<i>New Books</i> .....	84

DETAILS additional to those already published in SCIENCE have been sent out regarding the approaching anniversary meeting of the Association. The Rogers Building of the Massachusetts Institute of Technology will be the headquarters of the Association, and the preliminary meeting of the Council will be held there at noon on Saturday, August 20th. The Copley Square Hotel has been chosen as hotel headquarters. The first general session of the Association will be held at 10 a. m. on Monday, August 22d. The meeting will be called to order by the retiring President, Professor Wolcott Gibbs, who will introduce the President-elect, Professor F. W. Putnam. Addresses of welcome will be made by his Excellency Roger Wolcott, Governor of Massachusetts; His Honor Josiah Quincy, Mayor of Boston, and President James M. Crafts, of the Massachusetts Institute of Technology, and President Putnam will reply.

In the afternoon the addresses of the Vice-Presidents of the Association will be made before the Sections as follows:

*At half-past two o'clock.* Vice-President Whitman, before the Section of Physics: 'On the Perception of Light and Color;' Vice-President Cattell, before the Section of Anthropology: 'The Advance of Psychology;' Vice-President Farlow, before the Section of Botany: 'The Conception of Species as Affected by Recent Investigations on Fungi.'



At half-past three o'clock. Vice-President Barnard, before the Section of Mathematics and Astronomy: 'Development of Astronomical Photography;' Vice-President Blue, before the Section of Social and Economic Science: 'The Historic Method in Economics;' Vice-President Packard, before the Section of Zoology: 'A Half-century of Evolution, with Special Reference to the Effects of Geological Changes on Animal Life.'

At half-past four o'clock. Vice-President Smith, before the Section of Chemistry: subject to be announced; Vice-President Fairchild, before the Section of Geology and Geography: 'Glacial Geology in America;' Vice-President Cooley, before the Section of Mechanical Science and Engineering: subject to be announced.

On Monday evening Professor Wolcott Gibbs will make the address of the retiring President, his subject being 'On Some Points in Theoretical Chemistry.' President Eliot will address the Association at Harvard University on Friday evening, and it is expected that illustrated lectures will be given on Wednesday evening on the Boston Park System and the Metropolitan Water Supply and Sewage System.

The scientific work of the sections will be practically confined to two days, Tuesday and Thursday, excursions having been arranged for Wednesday, Friday and Saturday. As we have already stated, the excursion on Wednesday will be to Salem, where the Association will be the guest of the Essex Institute, while on Friday it will be the guest of Harvard University by invitation of the President and Fellows. On Saturday excursions have been arranged to Riverside, Wellesley, Concord and Lexington; various excursions have also been planned to follow the close of the meeting.

THE BREEDING OF ANIMALS AT WOODS  
HOLL DURING THE MONTH OF  
MAY, 1898.

THE opening of the Biological Laboratory of the United States Fish Commission made it possible for a number of naturalists to work at Woods Holl during the month of May, and it is hoped that the

abundance of animal life may attract others to the shore in 1899.

The temperature of the water during the month of May rapidly rose from 46 to 57 F. To this remarkable physical change both the fauna and flora responded, and the biological facies were materially altered.

Vertebrates.—The winter forms gradually disappeared and the familiar types of the warmer months began to arrive. The lampreys (*Petromyzon marinus*), ripe with eggs, were taken during the latter part of the month at East Taunton. Spiny dogfish (*Squalus acanthias*) were taken in Vineyard Sound, and *Raja ocellata* was abundant throughout the month, though probably not breeding. The transparent young of the common eel were frequently taken on the surface and in the shallow water. The fishermen say that the adults descend the streams while the alewives are passing up. This migration to the sea happens about the 12th, when there is the heaviest run, although many may be taken on subsequent nights. If the sky is clear and cloudless the catch is never so large as when dark and stormy. Late in the month several barrels of menhaden (*Brevoortia tyrannus*) were taken at Cuttyhunk, while throughout the month the skimming-net caught multitudes of young herring (*Clupea harengus*). *Fundulus heteroclitus*, ripe with eggs, was captured in great numbers at Falmouth on the 13th, where were also found two species of stickleback (*Gasterosteus bispinosus* and *Apeltes quadracus*), both sexually mature. An abundance of breeding pipe-fish (*Siphostoma fuscum*) were seined from eel-grass on May 13th, and they have been found, with pouches filled with eggs, as late as July 13th. The first mackerel (*Scomber scombrus*) was taken on May 3rd. A few butter-fish (*Rhombus triacanthus*) were taken in a trap at Cuttyhunk on the 11th, though reported at West Dennis on the 5th. They spawn in June.



Among the Serranidæ, *Roccus lineatus* usually arrives in May, although the present year we did not secure specific data. The white perch (*Morone americana*) spawns during this and the following month, and the sea-bass (*Centropristes striatus*), first seen on the 10th, was taken in large numbers on the 12th. It spawns in June. The scup (*Stenotomus chrysops*) were abundant at Cuttyhunk on the 11th, when thirty barrels were taken. It is said to spawn early in June. The squeteague (*Cynoscion regalis*), first taken in April, was occasionally brought to the station in May. The puffers (*Spheroides maculatus*) appeared during the latter part of the month, and a fine lump-fish (*Cyclopterus lumpus*) was also captured. The latter is said to breed in April. The Gurnards were represented by both *Prionotus carolinus* and *Prionotus strigatus*. It is estimated that there were at least one thousand in the trap on the 13th. Specimens examined on the 16th were not ripe, though the ovaries were large.

The Gadidæ abounded. Beautiful great pollock were almost daily brought to the laboratory; cod were so numerous that they found no market, and white hake (*Phycis tenuis*) was a positive annoyance to the fishermen. When so many inland laboratories are inadequately provided with animals for dissection it seems a great pity that hundreds of barrels of this beautiful material should yearly go to waste.

Among the Pleuronectidæ the summer flounder (*Paralichthys dentatus*) was often taken. The four-spotted flounder (*Paralichthys oblongus*) and the window-pane (*Bothus maculatus*) were abundant. Eggs of the four-spotted flounder were ripe in May, and have been hatched in the Chester jars. The period of incubation is about eight days. The eggs of the window-pane are of about the same size as those of *P. oblongus* and readily fertilize. The good eggs soon rise to the surface, leaving the

immature and injured eggs at the bottom. The sole (*Achirus fasciatus*) was apparently ripe the latter part of the month. *Lophius* was abundantly taken from the 'Sound' traps on the shore of Marthas Vineyard.

*Molgula* and *Ciona* were ripe throughout the month.

Crustacea.—*Gammarus annulatus* occurred in swarms. The tow-net at one haul, on the 16th, contained over two quarts, and the animals were so numerous that in places they gave a distinct color to the water. Many had eggs. On the 23d they were only occasionally found. *Orchestia agilis* bears eggs in May, and is, of course, abundant. When *Cyanea* comes to Woods Holl in May, it is often accompanied by *Hyperia*; the crustacean bears at this time most beautiful great eggs, almost perfectly transparent. On May 6, 1892, many were collected at Woods Holl, and on June 8, 1893, they were abundant in Narragansett Bay. *Idotea* was found at Nahant with eggs, May 20, 1893.

Schizopods, adults laden with eggs and young, were daily taken. Lobsters began to hatch on the 16th, and thousands were planted in Vineyard Sound during the latter part of the month. *Crangon* was often heavy with young, though *Palaemonetes* did not deposit its eggs until the latter part of the month. *Eupagurus longicarpus* was found bearing well-developed eggs on May 9, 1890, and on May 16th the eyes of the embryos could be seen. *Carcinus granulatus* often had eggs, as did *Gelasinus* and *Libinia*. The crabzæa were first taken in the skimmings on the 10th, and were abundant on the 11th. *Hippa*, though often taken, was without eggs. Pairs of *Limuli* might have been collected by the hundred.

Vermes.—The tow-net brought in many surface forms. On the 7th *Autolytus* was taken, but without eggs. On the 10th several egg-bearing individuals were noted, and on the 11th Dr. Mead saw a male

swim about like an excited *Nereis limbata* and finally fasten to one of the females with his jaw. Throughout the latter portion of the month *Autolytus* was taken in abundance. On May 17th swarms of Terrellids were observed to migrate from the clusters of *Parypha*, brought to the laboratory from Quick's Hole, and to gather on the sides of the aquaria. *Lepidonotus* bred throughout the first half of the month, and ripe females have been found as early as April 25th. Dr. Mead informs me that if the females are captured during the day they will deposit their eggs at about 6 p. m. The ripe females are generally greenish drab on the lower side, while the males are pinkish white. If the stagnant water, in which the animals have been retained during the day, is replaced by fresh sea-water the eggs or sperm will be seen to leave the nephridial openings of the posterior two-thirds of the body in streams. Since the eggs after fertilization settle to the bottom, the water may be renewed without difficulty. The embryos swim in from eight to ten hours and the gastrula stage is reached in about twenty hours. *Harmothoe*, found in the same localities as *Lepidonotus*, from which it is distinguished by having eighteen rather than twelve pairs of scales, breeds about one week earlier. The eggs may be secured and fertilized in the same way as those of *Lepidonotus*. The ripe females are bright pink on the lower side.

Dr. Mead found *Seolecolepis viridis* and *Clymenella torquata* breeding during the early part of May. The eggs of the former species are found in the sand-tubes; those of the latter are very large, but difficult to secure because of the shortness of the breeding season. Specimens absolutely ripe extrude the eggs in confinement, but if not absolutely ripe the eggs degenerate without being extruded. *Nereis limbata* was found swimming on the surface on the 13th. *Spirorbis* breeds during May, and the fully

formed embryos may be shaken from the *Fucus*, to which the adults are attached. Fine large egg-bearing specimens of *Sagitta* were abundant until the middle of the month.

Dr. E. G. Gardiner reports that the small acœlous planarian, *Folycheerus caudatus*, was repeatedly found, that several examples of a large species of *Monotus*, collected near the Laboratory, laid thousands of eggs upon the walls of the glass jars in which they were confined, and that *Plagiostomum* freely laid in captivity. He also found great numbers of *Dinophilus*.

Mollusks.—The squid (*Loligo pealii*) made their appearance on May 7th, when several hundred were taken at Hadley Harbor. Many eggs in early stages of development were found, and the animals occasionally laid in the aquaria. Artificial fertilization is easily accomplished. Many squid were taken throughout the month, and one egg-mass found attached to a fish trap filled a large bucket. *Urosalpinx* was found breeding on the 21st. The sand-collars of *Lunatia* were frequently brought into the Laboratory, and naked mollusks often deposited their eggs in the aquaria.

Echinoderms.—On May 10th *Echinarchnius parma* showed no sign of exhaustion; larvæ of *Cribrella* were taken in the tow-net, and the Ophiurans, abundant at North Falmouth, contained only immature eggs. An earlier note, made at Nahant, reports *Ophiopholis* as ripe May 20, 1893.

Cœlenterates.—*Pleurobrachia rhododactyla* was not abundant. The reproductive elements were found to be ripe by Dr. McMurrich towards the end of May, 1890. *Bera* was taken at Newport, R. I., on May 7, 1896, and at Bristol, R. I., on May 15th. *Mnemiopsis* and *Cyanea arctica* were only occasionally found. The planulæ of the latter may be easily raised in the Laboratory. They attach themselves in from seven to ten days after the eggs have left

the parent. A few *Aurelia* of medium size were taken on the 7th, and again on the 16th, 17th, 18th and 19th.

On May 10th a few small specimens of *Tubularia couthouii* were dredged at Quick's Hole, and the large stems of specimens dredged on the 17th seemed to show signs of regenerative processes. On the 11th hydromedusæ were hatched from hydroids of *Obelia*, and on the 13th a few were seen in the water around the station. *Tima formosa* was not seen during the month, though in 1896 the species was abundant in Narragansett Bay.

H. C. BUMPUS.

#### NATURAL HISTORY MUSEUMS (II).

##### THE MUSEUM AS A TEACHER.

THE museum, by an intellectual treatment of its collections, has, as I have shown already, discharged a large part of its function as a teacher. It remains for it to provide guides and lectures. The guides can be small books, leaflets or albums. The lectures are a more important feature. They are inaugurated in many museums; the series given in Washington, under the auspices of the National Government, and those given in London by the British Museum are examples illustrating this feature at its best. Lectures demand for their best popular value a combination of a firm and thorough command of the subject, a simple and yet adequate verbal exposition which may with some, according to their exceptional talent, assume a high literary quality, and lastly ample and stimulating illustration, either in slides by projection or in natural specimens. It is unnecessary to discuss the best form of a lecture. One point can be conclusively claimed, that the feature of entertainment should not expel out of all semblance of existence correct definite instruction, and that the philosophy of the topic should not be presented in broken half-truths, but envelop the listener with the penetrating atmosphere of thought.

##### THE MUSEUM AS AN INVESTIGATOR.

The museum completes its scope of relations to the great world of scientific interests when it uses its resources in the prosecution of original research and in publishing that which requires publicity. Biological problems are more naturally carried on in schools devoted to that subject, but the gathering of evidences and facts in natural history, facts bearing on distribution of animals, their habits and physiology, the solution of problems in ethnography and archæology, the collecting of new and valuable specimens in geology and mineralogy, the illustration of faunas and floras, description of new species, and revision of old, are topics which naturally engage the attention of the Museum of Natural History. The series of publications that have proceeded from the Smithsonian Institution, the National Museum, and the Museum of Comparative Zoology at Cambridge, form a library of research and generous compilation almost unrivalled.

##### THE AMERICAN MUSEUM OF NATURAL HISTORY.

In 1867 New York was without a museum. The American Academy of Arts and Sciences had in Boston brought together collections which formed a nucleus for yearly accretions, and furnished material for study and publication. In Philadelphia Franklin had unmistakably imparted, by example and a contagious influence, the spirit of research to groups of scientific minds. The American Philosophical Society and the Philadelphia Academy of Sciences by their important papers, the accumulation of a varied store of material, and the establishment of a remarkable library, furnished the most significant monument to the imperishable ardor of the great printer.

In Washington Smithson had laid the foundation of a museum and established a



bureau of publication and exchange which brought into correspondence the scientific workers of the world. In Cincinnati, a city rejoicing in a neighborhood which yields the most multifarious vestiges of a past life, a museum had been organized, and here Anthony, a pupil of the elder Agassiz, held sway over a local group of conchologists. In Albany the fruits were chiefly garnered of the classic survey of this State, that, inaugurated in 1836, marked an era in the history of geological science in this country, and deciphered an alphabet in geological formations that has been applied to all its other sections. In Chicago a museum under the genial inspirations of Stimpson had assumed mature dimensions.

There were clubs of collectors in New York, and the K. K. Club of Brooklyn is yet pleasantly remembered by its older citizens, who may have there displayed before envious eyes a rare *cypræa*, a precious volute, an unsurpassed cone or a unique olive. A philosophical society had, indeed, expired in New York after issuing an exhaustive claim to continued existence. The New York Lyceum succeeded it, and here Torrey, Draper, Wheatley, Redfield and Dekay created the elements of a scientific association. In 1865 its collections of considerable value were destroyed by the flames which razed to the ground the old Medical School of the University, but later it sprang into prominence under Newberry, and maintains to-day a prolific scientific vigor under the guidance of Julien, Osborn, Britton, Kemp, Dean and Doremus.

Such preparatory stages brought into notice the enthusiastic designs of Mr. Waterhouse Hawkins, an anatomist of repute and an artist whose imagination had reached an extreme point of fertility from the study of extinct forms of life. Mr. Hawkins captured the ear or the fancy of the officials of the Department of Parks, who involved their own rather mundane designs upon

Manhattan Square with Mr. Hawkins' terrifying restorations, and the result of this somewhat incongruous union was to be a sort of Sydenham Palace. Here was to be a bear-pit, amphitheatrical and boundless, surrounded with caves surprisingly natural; above this was contemplated a huge circus of rock becomingly wild and impressive, while a company of beavers, beyond this Rabelaisian structure, were to build dams fast and large enough for the sensational needs of a metropolitan audience. We read in the *Evening Mail*, Wednesday, October 27, 1869: "Caves with graceful tenants will surprise at every turn, tiny cascades will tumble down the rocks, wonders of the finny tribes will glisten in miniature lake and sedgy pool, and among the shadowy foliage overhead rare birds of gorgeous plumage will talk to us in unknown tongues." At this point Mr. Hawkins came in. There was to be a gloomy and half subterranean receptacle for his restorations, a sort of fossil catacombs wherein the visitor, suppressing his dismay and encouraging his understanding, would wander about through shapes of pre-Adamic existence, and escape again into the light of day like Marcellus and Bernardo, 'distilled almost to jelly with the act of fear.' New York was spared this unnecessary and theatrical episode.

R. L. Stuart, R. J. Steward, Theodore Roosevelt and H. Haines established the American Museum of Natural History. Professor A. S. Bickmore was associated with its very first years, having been engaged as its first Superintendent, while the venerable name of John David Wolfe as its first President, supported by a long list of prominent citizens, guaranteed it the requisite recognition in the State Legislature. Without pausing to recall the uneventful days of its inconspicuous life in the old arsenal in Central Park, I pass to that summer day in 1874 when the corner



stone of the first section of the present imposing structure was laid. I beg to quote from a paper on the Museum prepared by me in 1883: "It was in June. A large platform covered the newly-laid walls of the foundation, and above this rose their unfinished and irregular edges, inclosing a space crowded to its limits with expectant guests. A canopy over all tempered the propitious radiance of a summer sun; platoons of police kept open broad avenues of approach, and the constant roll of equipages and the occasional appearance of groups of distinguished men lent to the occasion an unusual and gala character. The scene was, in reality, not without a certain impressive and picturesque interest. Without the inclosure, the square, then broken by outcropping strata of gneiss rock and valley-like basins, was black with throngs of men for whom was then instituted a place of beneficial recreation; within, an assembly of beauty and culture, wisdom and executive prerogative, engaged in a ceremony contemplating honor solely to the genius of modern civilization."

President Grant laid the corner stone; Governor Dix spoke, and the great and wise Henry saluted it in a prophecy of mingled hope and admonition. I have elsewhere reviewed the nature and importance of the collections then displayed, and it is now auspicious, without wearying your patience, to explain the greatly changed conditions that prevail within it and its enormously expanded prospects and opportunities.

Upon the death of President Wolf Mr. R. L. Stuart succeeded to the presidency, and upon his demise, in 1882, Mr. Morris K. Jesup. It is really within the period of the latter's presidency that the Museum has entered upon the prerogatives and functions of a great museum. At the outset of an outline of the Museum's status it must be realized that in its relations to the city it is

partially a tenant of the city and partially a beneficiary. The city furnishes the corporation known as the American Museum of Natural History with a building adequate for its purposes, and pays to it also an annual sum sufficient for its proper maintenance and the care of its collections. On the other hand, the corporation represented by its officers and trustees furnishes to the people of the city free access (under the reservation of two pay-days a week) to its collections, which it engages to label and display so as best to promote the instruction of its visitors. There are five scientific departments in the Museum, a library, a business and a clerical administration.

The five scientific departments cover almost entirely the area of Natural History, and embrace Forestry, Mammalogy and Ornithology, Entomology, Invertebrate Paleontology, Invertebrate Zoology, Mineralogy and Economics, Ethnography and Archaeology. Objects and collections are secured by donation and purchase. The gifts which have enriched the Museum are princely. Mr. M. K. Jessup, the President, has given the exhaustive collection of American Forestry; Mr. J. Pierpont Morgan, the Tiffany collection of gems; Miss Catherine Wolf gave the Conchological Library of Dr. Jay, which is the nucleus of the present greatly enlarged collection of books. Mrs. Margaret Schuyler Elliot gave her husband's superb cabinet of bred Lepidoptera; Dean Hoffman, the exhibition collections of North and South American butterflies; James Angus, a varied collection of representative entomology; W. Schaus, the Old World moths. In ethnology and archaeology the Duke de Loubat, Henry Villard, J. Pierpont Morgan, B. T. B. and Frederick Hyde and Heber R. Bishop have given most valuable collections and supported expeditions, as the important one of H. Bandelier in Peru; while Mr. Jessup has inaugurated and maintained, and is

now administering, the expeditions to Mexico, Siberia and Alaska. Purchases upon a most munificent scale have secured such large collections as the Sturgis, Emmons, Terry and De Morgan in ethnology and archæology, the Haines in conchology, the Hall in paleontology, the Spang in mineralogy, the Baily and Bendire in oology, the Maximillian and Elliot in mammalogy and ornithology, the superb Elliot library on birds; and innumerable smaller purchases are yearly adding to the beauty and completeness of the cabinets. Perhaps the most astonishing and original exhibit contained in the Museum to-day is that of vertebrate paleontology. Professor H. Fairfield Osborn has practically created this department. He has supported it in its work in the field under Dr. Wortman, and he has brought to its installation a sympathy for the needs of the visitor and student, an unerring sense of correct and attractive arrangement, and he has stamped it with the impress of deep learning.

Amongst the very beautiful objects of the Museum halls, the realistic groups of birds and animals challenge a delighted notice. These admirable extracts from nature show the habitat of the animals reproduced with microscopic care and verisimilitude, the animals themselves in flight or motion or arrested in surprise or interest. The art of taxidermy has taken a high and justly celebrated place in the American Museum of Natural History, and Messrs. Rowley and Smith have felt the responsibilities of their keenly critical position. There are gems of taxidermy from the hand of Jules Verreaux where the apt instinct for anatomical relations reveals the character of the creature, where angularities of structure are not forgotten, and smooth contours are entered by lines of muscular or ligamental modeling. Taxidermists are apt to overstuff; if the subjects are large they are fattened with superabundant straw until, like Falstaff,

they are 'mountains of mummy'; if small, converted into rolling pins, or, as Flower says, are 'wretched and repulsive caricatures, out of all proportion, shrunken here, bloated there, and in impossible attitudes.' Taxidermy, like sculpture, is a study of the relations of muscles; with little difficulty it becomes the protean art of making pin cushions.

The Museum of Natural History in London is regarded to-day as the most perfect representation of an ideal museum of natural history in the world; 'after it the museum in Berlin, and, in about equal rivalry for the second place on the Continent, those of Vienna and Paris. The care with which the first two have elaborated the presentation of groups of birds and mammals afforded the suggestion for the groups now shown in the American Museum. These were at first largely created by the cooperative efforts and skill of Jenness Richardson and Mrs. Moggridge, an Englishwoman who had worked at South Kensington. The taxidermy at all these museums is of no higher order than that displayed in the American Museum of Natural history. The groups are more varied, are larger, and in many cases, as at Paris, are placed in more theatrical relations to the spectators. Such groups compose a feature wonderfully attractive, and are really to a large superficial class of visitors the most appreciated and helpful form of exhibit.

In the British Museum the influence of environment, the modifications of texture, and the progressive changes in dermal appendages and skin, together with ample morphological illustration, supplement these pure nature studies and embody a magnificent lesson in zoology. Such advances Dr. J. A. Allen contemplates in the American Museum in New York.

The detailed or even general description of the collections is impossible in a sketch devoted to blocking out the conformation

simply of this great Museum. They have grown and spread and their multitudinous aspects defy compression within the limits of a reasonable and readable essay. But one characteristic of the present development of the Museum should receive attentive consideration.

President Jessup has, I presume, upon mature deliberation thrown the energies of this institution largely in the direction of ethnographic study. Expeditions have been and are to-day despatched into distant sections of indigenous culture to bring back the implements, the dresses, the idols, art and industry of savage or semi-savage or pre-historic races. Comparative studies in culture, religion, language, myth, art, are to be instituted, and the converging lines of such research are to be directed towards that baffling problem of the origin of the American race. American archæology is to be explored and its many phases, from the Indian arrow head to the Palenque altar pieces and the slightly varying cultures of Toltec, Miztec, Zapotec, Nahuatl and Maya, examined and substantially illustrated.

While it is an affected propriety to say 'the proper study of mankind is man,' and while we may with earnestness recommend the curiosity which hunts diligently for any light which reveals the relations of races, their origin, migration and changes, yet the endless collections of pottery, stone implements, textiles, weapons, industrial work and religion might often seem judiciously discouraged. A museum of natural history cannot conveniently or profitably merge its character into that of a museum of comparative ethnology and archæology. It must retain preëminently its office of revealing the realm of nature rather than that of artifice. It must exhaust its resources in a search for the marvels of the animal and mineral kingdoms, and for the revelations of geology. It must increasingly regard its mission as concerned essen-

tially with the lessons and the beauties which are involved in and which decorate the faunas or floras of the earth and those which challenge our enthusiasm in the marvels of crystals and the story of the globe.

The publications of the Museum embrace a series of bulletins now in its ninth volume, and a series of memoirs scarcely begun. They are liberally exchanged with foreign and domestic societies, with individual workers, libraries and institutions of learning. They comprise a great diversity of subjects and are a record of original work of supreme interest. The library has by growth, exchange and gift reached a commanding size and numbers thirty thousand volumes.

The Museum has formed the most flattering alliances with societies that meet within its walls, and with the University of Columbia, which sustains a course of winter lectures in its lecture hall. It is one station of the free lectures of the people under Dr. Leipziger, and its platform and admirable equipments for illustration, designed by Mr. L. C. Landy, are in constant requisition for lectures on travel, botany and natural history.

The lectures given by Professor A. S. Bickmore under the auspices of the Department of Public Instruction are first delivered here, and afterwards with the accompanying slides distributed to the State Normal Schools and to the superintendents of education in towns and incorporated villages. The educational activity of the Museum is thus seen to be commendable, and, while scarcely on a level with the superabundant and richly varied instructions given by the Brooklyn Institute, its resources in illustration somewhat overweigh the tireless ingenuity with which the area of possible knowledge is explored by the directors of the institution at Prospect Park.

Material is being steadily accumulated for original investigations, and in the De-



partment of Zoology such 'Study Series' have reached surprising dimensions. These series are strikingly accumulated in the British Museum, and their important bearing upon the scientific welfare of the Museum was expressed by Professor Flower in these words. He says the Study Series "contains all those exceedingly numerous specimens (in many groups, the great bulk of the collection) showing the minute distinctions which are required for working out the problems of variation according to age, sex, season and locality, for fixing the limits of geographical distribution, or determining the range in geological time. It is this part of the collection that zoologists and botanists resort to, to compare and name the animals and plants collected in expeditions sent to explore unknown lands; to work out biological problems of the highest scientific importance, and generally to advance the knowledge of the science. In fact, these reserve collections, occupying comparatively little room, kept up on comparatively little cost and visited by comparatively few persons, constitute, from a scientific point of view, the most important part of the Museum, for by their means new knowledge is obtained, which, given forth to the world in the form of memoirs, books or lectures, is ultimately diffused over a far wider area than that influenced even by the exhibited portions of the Museum. Indeed, without the means they afford, the order, arrangement and power of imparting knowledge which the galleries possess would not be possible."

With such a compressed summary of the salient features of this Museum, which it is hoped will yearly grow more consummately into the best expression of a museum of natural history, I ask your forbearance, though in asking it I am merely anticipating your natural wishes, in considering how practically helpful this institution is in raising the popular standard of thought or

desire. My own views on this question are very simple and emphatic. There are very unnecessary exaggerations of the influence of a museum. Upon some people it simply produces surprise. Its size, the diversity of its contents and the unintelligible nature of its labels produce in them a confusing consternation, consternation in which are discernible some self-reproaches for neglect of their own culture, considerable astonishment at that of others, and a pervading atmosphere of wonder as to 'how much money do you suppose it's worth.' Now this class is numerically large. It includes young, middle-aged and old, and while, of course, upon them, in ratio to their peculiarities of mind and disposition, the survey of well-arranged collections must leave wholesome, pleasurable and, perhaps, instructive impressions, the sum-total of all of their impressions will never materially change one way or another the intelligence of a community. A museum, or the directors of a museum, must indeed remember that it is a place essentially of recreation for the great majority. This recreation is far from unimportant. It is remedial, sanitary and of moral efficacy. But I can scarcely believe that it especially instructs. It opens people's eyes, gives them an increased respect for knowledge, and probably amongst parents fortifies their intention to give their children all the education they can afford to give them. I do think they derive certain emancipating ideas about time and creation, and are made probably a little more receptive of progressive thought. I allude, of course, only to scientific museums. The recreation obtained in art museums is more valuable to this class than that secured in the museum of natural history. The material of the art museum appeals more obviously to the eye, thence to the mind and thence to the memory. It involves so many illusions to taste, reading, association and experience.



The second and remaining groups are included in the number who have met these objects of study in the class room, the lecture hall, are collectors, or from reading or conversation, or any other line of contact feel an interest in the specimens themselves, in their arrangement and in their elucidation. This is a respectable number and from the nature of things is constantly growing. But this observation emphasizes the relation in which the museum stands to education in natural history. The intelligent constituency of a museum of natural history are those who know something about its contents. And the extension of natural history study in the schools or colleges is directly promotive of the interest of the museum. The duty, then, of the museum is unmistakably to justify such extension of study by its own ample and adequate and lucidly prepared collections.

This view receives confirmation in the experience of the Carnegie Museum at Pittsburg. The first sentences of the report for 1896 of this institution contains the following paragraph: "With the opening of the second year of the Carnegie Museum the institution found itself occupying a most favorable situation. Its growth during the first year had been phenomenal. The public mind, however, had not kept pace with its progress. While the attendance was always good, the people seemed to make no serious study of the many interesting collections. This was particularly the case on the part of the younger visitors, who came frequently but seemed rather to take a general view than to make a careful inspection." To awaken the critical interest which seemed absent, the Museum Committee conferred with the Superintendent of Public Schools of Pittsburg, and as a result offered a prize essay competition for the pupils of the high schools and high school classes of the public schools. The competing essay was to take the form of a

letter, limited to two thousand words in length, from the various contestants to a friend describing a visit to the Museum. The flattering result of this scheme is thus described in the same report:

"No sooner had the circulars been published in the newspapers and distributed to the pupils than the expected result ensued. The pupils of the two chosen grades flocked to the Museum, accompanied by parents and friends, and the habit of careless sauntering immediately gave place to minute and studious observation. Those who designed to compete for the prizes used their note-books for describing the objects, having been cautioned by the committee's circular against making mere lists of the labels or the use of technical language, and informed that the committee preferred 'an intelligent, comprehensive and general description rather than itemized statement or complete catalogue,' nor was this improvement in the method of studying the museum confined alone to the contesting pupils, for the whole body of visitors was observed to take a deeper interest in the inspection of the objects."

In other words, the collections of the Museum become objects of study, of reflective observation, and probably are memorized as to their nature, meaning and relations when a motive of interest prevails to such an end with their visitors. In the accidental case adduced it was a motive of ambition, with some mercenary considerations partially involved. But the motive that can be most generally invoked is one springing from previous knowledge. We all naturally examine new illustrations of what we have studied, what we have collected, or what we have heard about. The profuse admiration of men and women, boys and girls, in the halls of the Museum, over the shells and the birds, and gems and minerals, means almost nothing. Remove these hysterical eulogists to the outside of

the Museum, distract them for a moment by a mechanical carriage, a street procession or an April shower, and I doubt if the *distinct* recollection of one shell, one bird, one gem or one mineral could be satisfactorily traced upon their minds.

Of course, the Museum helps the great populace; it gives them a pleasant and desirable environment of order and beauty and interest, but its educational power in a specific sense is limited almost entirely by knowledge, previously acquired amongst its visitors, of the things it contains. But let no maleficent construction be given to these words. The Museum of Natural History is a wonderfully helpful adjunct to all forces leading to sanity and happiness. To the most untutored it brings delightful revelations of the variety and the mystery of nature, and to those who love that wide retinue of facts and impressions which the fields and the woods, the tenanted air and the resounding sea, constantly yield, how full and eloquent it seems!

The consecrated attitude of mind which in Wordsworth's Ode on the Intimations of Immortality, expressed its ecstasy in the wonderful lines:

“And O ye fountains, meadows, hills and groves,  
Think not of any severing of our loves!  
Yet in my heart of hearts I feel your might;  
I only have relinquished one delight,  
To live beneath your more habitual sway;”

or that intensity of absorption with Nature which made the hand of Thoreau pen these salient phrases in his Cape Cod: “We often have to think now of the life of men on beaches—at least in mid-summer when the weather is serene; their sunny lives on the sand, amid the beach-grass and the bay berries, their companion a cow, their wealth a jag of driftwood, or a few beach-plums, and their music the surf and the peep of the beach-bird;” both of these relations to Nature so contrasted, rediscover in the museums of natural history the stimulus

and the justification to their satisfying joys.

L. P. GRATACAP.

AMERICAN MUSEUM OF NATURAL HISTORY.

---

GEORGE BAUR.

THE telegraphic despatches have brought us the sad information of the death of Dr. George Baur, of the University of Chicago.

About a year ago Dr. Baur was compelled to quit his work and to seek rest. It has been known to some of his friends that his state of health was not improving, but his death must come as a surprise to all. Some of his more intimate friends will doubtless give us a biographical sketch of this young, but already eminent naturalist. The writer, who enjoyed somewhat close association with him for a space of four years, desires to pay a tribute to his memory.

Dr. Baur was a native of Germany and he took his doctor's degree at the University in Munich in 1882. Here he studied histology under Dr. Kupffer and paleontology under the distinguished Dr. Karl Zittel. He had previously spent some months with Dr. Leuckart in Leipzig. He gave special attention to osteology and vertebrate paleontology, and his inaugural dissertation was entitled ‘Der Tarsus der Vögel und Dinosaurier.’ It appeared in the *Morphologisches Jahrbuch* for 1882.

Unless the writer is in error, Dr. Baur came to this country in 1884. He became assistant to Professor O. C. Marsh, in the paleontological laboratory of the latter at New Haven, and continued in this position until January, 1890. During this period he devoted his energies to the fossil reptiles, a group to which he ever afterwards gave especial attention, and upon which he published a number of papers. During the summer of 1890 he spent some time in western Kansas, where he collected fossil reptiles and fishes for Dr. Zittel. Shortly after leaving New Haven he received a call

to Clark University, Worcester, Mass., where he lectured on his favorite subjects. By this time he had become interested in the problems of geographical distribution of organisms and his attention was turned to the Galapagos Islands. Having succeeded in interesting influential persons in his scheme, he left New York for these islands on May 1, 1891, and arrived at Chatham Island, June 8th. He visited in succession Hood, Barrington, Indefatigable, Albatross, Duncan, Indefatigable again, Jervis, Albatross again, James, Chatham again, Tower, Bindloe and Abingdon islands, and everywhere made abundant collections of animals and plants. He had intended to visit all the islands of the group, but tidings of sickness in his family compelled him to hasten home. He reached New York on October 2d.

At the opening of the University of Chicago, in 1892, Dr. Baur was called to the chair of comparative osteology and vertebrate paleontology in that institution, and this he occupied until his death. His age did not exceed forty years. He leaves a wife and four children.

Dr. Baur's contributions to science consist of probably one hundred or more papers. Other and more extensive works were in process of preparation. Among these is an account of the tortoises of North America, which was to have been published by the National Museum. This work must have been completed or nearly so, and will probably appear in due time.

Dr. Baur's especial interest was in the morphology of the vertebrate skeleton. Although he recognized the great value of descriptive osteology, such work alone did not satisfy the demands of his mind. Although he wrote much on vertebrate paleontology, he was the describer of few new genera and species. His constant effort was to discover the relationships of forms and the way in which they had originated.

He was thus impelled to study the homologies of the various bones and to attempt to connect them with the skeletons of more primitive forms. In many of his papers we find attempts made to unravel the genealogy of groups and to base classifications on this genealogy. His views regarding the scope and the methods of comparative osteology may be learned from a lecture published in SCIENCE, 1890, Vol. XIV., p. 281.

Some of the parts of the skeleton to which he gave especial attention are the carpus and tarsus, the vertebral column, and the bones of the temporal region. His opinions on all questions resulted from a careful study of the material objects involved, from a comparison of these with one another, and from examination of the views of other scientific men. His ideas were expressed in clear and simple language, quite in contrast with the usual German style, and one reads after him with pleasure and profit, even if one does not agree with him. His acquaintance with scientific literature was extensive, and his papers are usually enriched by a full bibliography of the subject discussed. He possessed an independent spirit, and in the utterance of his opinion he stood in awe of no authority. He had strong convictions; and, possibly, sometimes in the heat of discussion he may have expressed himself with some asperity. Although he maintained his opinions with vigor, he was open to conviction; and an examination of his papers will show that he later held views quite different from those advocated at an earlier period. Dr. Baur's studies on the carpus and tarsus resulted in several papers which appeared in the *Morphologisches Jahrbuch*, *American Naturalist*, SCIENCE, and the *Zoologischer Anzeiger*. His views were summed up in a short paper published in the *American Naturalist* for July, 1885.

In studying the development of the limbs Dr. Baur held that the Amniota which possessed more than five fingers were highly



specialized forms and not primitive ones presenting transitions from the fishes. His view is now probably very generally accepted.

A number of his papers related to the structure and the systematic position of the leather-back turtle, *Dermochelys*. He opposed strongly the views of Cope, Dollo, Boulenger and Lydekker that this reptile forms a suborder distinct from all other living tortoises. He regarded it as belonging to merely a highly specialized branch of the Pinnata, a group which contains our living sea-turtles.

The structure and relationships of the Mosasauridæ form the subject of several interesting papers. In opposition to Professor Cope, who maintained that these extinct reptiles bore special relationship to the snakes, Dr. Baur held that they were true lizards, closely related to the Varanidæ, but modified for adaptation to an aquatic existence. An excellent paper on the structure of the skull of the Mosasauridæ was published in the *Journal of Morphology* for 1892.

As early as 1886 Dr. Baur wrote a paper on the homologies of the bones of the otic and temporal regions. His interest in the subject never relaxed and some of his latest papers were written in a discussion of the subject with Professor Cope.

In the same year above mentioned, 1886, Dr. Baur became interested in the morphology of the vertebral column, and he published a paper of considerable length in the *Biologisches Centralblatt* of that year, stating his conclusions. He gave his adherence to the opinion of Cope, who held that the vertebral centrum in all the Amniota has developed from the pleurocentrum, an element which is found distinct in the Stegocephali. He found confirmation of his views in the vertebral axis of the Pelycosaurian reptiles, in *Sphenodon*, certain lizards, birds and even mammals. He ad-

vocated the same views in one of his latest papers.

In the *American Naturalist* for May, 1891, occurs an important paper by Dr. Baur on the reptiles known as the Dinosauria. In a characteristic manner he gives the history and the literature of the subject and his own conclusions. His opinion was that 'the Dinosauria do not exist.' He believed that this group is an unnatural one, and is made up of three special groups of archosaurian reptiles which have no close relation to one another.

Two of Dr. Baur's most important later efforts are probably one entitled 'The Stegocephali,' a phylogenetic study, published in the *Anatomischer Anzeiger* for March, 1896, and one, a joint paper with Dr. E. C. Case, having the title 'On the Morphology of the skull of the Pelycosauria and the origin of the Mammalia,' and appearing in the *Anatomischer Anzeiger*, 1897, pages 109-120. In the first mentioned paper Dr. Baur compares the skeletal structure of the Stegocephali with that of various fishes and comes to the conclusion that the Batrachia took their origin from the Crossopterygia, rather than from the Dipnoi. The second paper was based on the fine materials collected by Dr. Case in the Permian formation in Texas. The authors concluded, on the one hand, that the Pelycosauria are closely related to the Rhynchocephalia and that, on the other hand, they could not have been the ancestors of the mammals. The authors were inclined to regard the Gomphodontia as the ancestors of the mammals.

After Dr. Baur's return from the Galapagos Islands, he devoted a considerable portion of his attention to the study and discussion of the problems which arose from the examination of the materials which he had there collected, and which had to a great extent been turned over to specialists. His conclusion with regard to the origin of those islands was that they had originally been



connected with the continent of America and were the result of enormous subsidence. Previously the opinion was almost universal that they had resulted from elevation and volcanic action. He supported his views in a number of papers and lectures; and, while meeting with strong opposition, he had the satisfaction of making several distinguished converts.

About a year ago we were called upon to mourn the departure of a leader in the study of the beings of long-gone ages, Professor E. D. Cope; now paleontology has suffered the loss of Dr. George Baur, cut off in the midst of a brilliant career.

O. P. HAY.

U. S. NATIONAL MUSEUM.

#### CURRENT NOTES ON ANTHROPOLOGY.

##### THE LATEST ASIATIC-AMERICAN AFFINITY.

It is painful to see good ink and paper wasted to prove affinities between American and Asiatic tribes, when the only fact proved is the ignorance of him who asserts them.

The latest example is M. Ed. Blanc, who in the *Journal de la Société des Américanistes*, of Paris, No. 3, undertakes to exhibit the relationship between the Nahuatl, spoken by the Aztecs, etc., in Mexico and the language of the Avars in the northern Caucasus! He also considers the incidents of this imaginary migration.

When, by turning to General von Erckert's fine volume on the Caucasian languages or the earlier works of Professor F. Müller, M. Blanc could have learned that the Avar (Awarisch) is a well recognized member of the Lesghian linguistic stock and is quite familiar to students of such matters, it is scarcely pardonable that he should have burdened the pages of a scientific periodical with his fantastic hypothesis.

##### THE STUDY OF LOCAL ETHNOGRAPHY.

PROFESSOR M. D. LEARNED, of the Uni-

versity of Pennsylvania, has undertaken the study of the ethnography of Pennsylvania on lines which it were well to have generally adopted. He distributed circulars of inquiry relating to ethnographic material, such as dialectic peculiarities; ballads; local history, traditions and folk-lore; changes in names of persons and places; collections of books and antiquities; manuscripts, etc.

The answers he has received have been gratifying, and he expects to incorporate the results in a series of publications treating separately each ethnic element, the German, English, Swedish, Welsh, etc. Ethnographic charts will be added 'setting forth the cultural epochs and racial complexion of the present population and indicating the speech boundaries.'

This is in the line of what the proposed 'Ethnographic Survey of the United States' hoped to accomplish. (For further particulars see the *University Bulletin*, Vol. II., No. 4, May, 1898.)

##### WOMEN AS ANTHROPOLOGICAL STUDENTS.

We have in Washington the only 'Woman's Anthropological Society' in the world, but by no means all the women who study anthropology.

The roll of French anthropologists contain not a few names of the fair sex who have accomplished notable work. Madame Clementine Royer, of Paris, is one of distinction; Madame Chantre, of Lyon, has published excellent anthropometric material; and in the last *Bulletin* of the Anthropological Society of Paris for 1897 Madame Martin presents an instructive study of the statistics of the population of France in 1895, and Madame Chellier a series of anthropometric observations from Aurès, French Africa.

It might be difficult to name an equal array among the Germans; but in the *Globus*, May 21st, Dr. the Countess von Lin-

den, Assistant in the Zoological Institute at Tübingen, repels with a keen pen and abundant knowledge an attempt of an anthropologist to shove her sex into the background by an appeal to 'the laws of nature.'

#### ON STONE PENDANTS.

THERE is a class of stone relics polished on the surface and pierced with an orifice. They were evidently intended to be worn around the neck. For this reason they are in Europe classed as amulets, with us as 'gorgets.' In the *Prähistorische Blätter*, No. 3, Professor Mehlis describes and figures several found in the Palatinate. They closely resemble American types, and are about two inches in length.

In an excellent article by Professor Sophus Müller in the *Mémoires* of the Royal Society of Danish Antiquaries, 1897, the author reviews a number of new types of artefacts from the Stone Age. Among them is a series in amber of perforated objects evidently intended to be worn by suspension. The two most remarkable identified by him as amulets are faithful copies of the stone axe of the period; and Professor Müller considers them 'of particular importance as showing that the axe served as a symbol during the Stone Age.'

The same fact has been recently demonstrated of some American stone pendants by Mr. F. H. Cushing, quite independently of Professor Müller's observations.

D. G. BRINTON.

UNIVERSITY OF PENNSYLVANIA.

#### SCIENTIFIC NOTES AND NEWS.

SCIENTIFIC SOCIETIES AFFILIATED WITH THE AMERICAN ASSOCIATION FOR THE ADVANCEMENT OF SCIENCE.

THE scientific societies meeting before or simultaneously with the Association and more or less closely affiliated with it are as follows:

*The American Mathematical Society* will meet on Friday and Saturday, August 19th and 20th,

in room 11, Rogers Building, Massachusetts Institute of Technology. F. N. Cole, Columbia University, Secretary.

*The American Forestry Association* will meet on Tuesday and Wednesday, August 23d and 24th, in Horticultural Hall, 101 Tremont street, Boston, the official headquarters of this Association. Francis H. Appleton, Boston, Mass., President.

*The Geological Society of America* will meet on Tuesday, August 23d, at the same time and place with Section E. J. J. Stevenson, New York, N. Y., President; H. L. Fairchild, Rochester, N. Y., Secretary.

*The American Chemical Society* will hold its seventeenth general meeting on Monday and Tuesday, August 22d and 23d. The first session will convene immediately after the organization of Section C of the A. A. A. S., and in the same room, on Monday morning. On Monday afternoon at 4.30 the Society will give place to Section C, in order that the chemists may all have the opportunity of listening to the Vice-President's address before that body. The whole of Tuesday will be devoted to the American Chemical Society, and the remainder of the week to Section C. Charles E. Munroe, Columbian University, Washington, D. C., President; Albert C. Hale, 551 Putnam avenue, Brooklyn, N. Y., Secretary.

*The Society for the Promotion of Agricultural Science* will meet in Horticultural Hall, 101 Tremont street, on Friday and Saturday, August 19th and 20th; C. S. Plumb, Lafayette, Ind., Secretary.

*The Association of Economic Entomologists* will hold its tenth annual meeting in the Natural History Building on August 19th and 20th. Herbert Osborn, Ames, Iowa, President; C. L. Marlatt, Washington, D. C., Secretary.

*The Botanical Club* of the Association will meet at a time to be announced.

*The Society for the Promotion of Engineering Education* will hold its fifth meeting in room 22 of the Walker Building of the Massachusetts Institute of Technology, August 18th, 19th and 20th. J. B. Johnson, St. Louis, Mo., President; Albert Kingsbury, Durham, N. H., Secretary.

*The American Folk-Lore Society* will meet

with Section H on Thursday, August 25th. W. W. Newell, Cambridge, Mass., Secretary.

The *American Psychological Association* will meet with Section H on Thursday, August 25th. Professor Hugo Münsterberg, Harvard University, President; Dr. Livingstou Farrand, Columbia University, Secretary.

The *National Geographic Society* will meet with Section E in the Natural History Building on Thursday, August 25th.

The *Botanical Society of America* will meet in 26, Rogers Building, on Friday and Saturday, August 19th and 20th. On Friday, at 8 p. m. Professor John M. Coulter will give the address of the retiring President; on Saturday, at 9:30 a. m. and 2 p. m., there will be sessions for reading papers.

A *Conference of Astronomers and Physicists*, similar to that at the dedication of the Yerkes Observatory, will be held at the Harvard College Observatory on Thursday, Friday and Saturday, August 18th, 19th and 20th.

#### THE CORAL-BORING EXPEDITION TO FUNAFUTI.

*Natural Science* takes from the *Sydney Daily Telegraph* the following information regarding the coral-boring expedition to Funafuti which will this summer resume work at the old bore at a depth of 698 feet. Lining pipes, which were on the former occasion lowered to a depth of 650 feet, will be reinserted and extended to the full depth. Boring can be begun on the unproved rock, which is expected to be similar to that met with during the previous 30 feet of the old bore, namely, a white calcareous rock of about the consistency of hard chalk. Professor David expects that the bed-rock will be reached within a depth of 200-300 feet from the bottom of the old bore. Early in August it is hoped that H.M.S. 'Porpoise' will bring from Samoa apparatus for putting down a bore in the bottom of the Funafuti lagoon. Commander F. C. D. Sturdee intends to moor his ship taut at low tide at a spot in the lagoon, which will be about a mile and a-half westward from the main village. A boring platform will be fixed at the bows, whence pipes will be let down to the bottom of the lagoon, which at the spot selected is about 100 feet deep. As soon as the pipes strike the bottom of the lagoon a power-

ful stream of water will be forced down by means of a flexible hose connected with a large Worthington steam pump. It is hoped that then, if the bottom of the lagoon consists, as is thought probable, of soft and loose sedimentary material, a fair depth may be attained in the few days available for the use of the warship for the purpose. Work will be carried on at the lagoon day and night. It should be possible from time to time, by shutting off the water jet and lowering a sand pump inside the pipes, to obtain small samples of the formation which is being penetrated. If this bore in the lagoon is successful it will much enhance the value of the main bore put down with the diamond drill. The reason why it is proposed that the bore in the lagoon shall be situated only a mile and a-half from the shore, instead of near the center, is that one of the chief difficulties will be the danger of the ship dragging at her moorings. This would be intensified near the center of the lagoon, where the full force of the squalls, trade winds and strong currents would be experienced. At the spot contemplated, however, the warship should be not only out of the main current, but also somewhat sheltered on the coast by the thick belt of cocoanut palms and other trees with which the main island is densely wooded. After finishing the boring experiment in the lagoon, the 'Porpoise' will proceed to the Gilbert Islands, and on her return, early in September, she will be ready to pick up the diamond drill party and convey them to Suva. Should, however, the main diamond drill bore not have been bottomed up to the date of the return of the warship to Funafuti, arrangements have been made by the London Missionary Society which will admit of their steamer, the 'John Williams,' due at Funafuti in November, carrying the party either to Suva or New Guinea, whence they would return to Sydney.

#### DIETARY STUDIES.

PROFESSOR W. O. ATWATER and Mr. C. D. Woods have published, through the Department of Agriculture, interesting studies of the diets of families living in a congested portion of New York City, together with studies at a mission and a day nursery in the same region. The abstract of their 117-page paper in

the *Experiment Station Record* states that the families were selected as typical of the so-called poor classes usually encountered by philanthropists and mission workers in the congested districts of large cities.

Tables are given showing the kind and amount of food purchased, wasted and eaten, and its cost, composition and fuel value. The results are briefly summarized as follows:

*Results of dietary studies—cost and composition of food eaten per person per day.*

	Cost.	Protein.	Fat.	Carbohy- drates.	Fuel Value.
	<i>Cents.</i>	<i>Grams.</i>	<i>Grams.</i>	<i>Grams.</i>	<i>Calories.</i>
Mechanic's family.....	31	149	128	526	3,955
Carpenter's family.....	23	148	144	458	3,825
Jeweler's family.....	18	99	104	296	2,595
Sailor's family.....	26	139	143	558	4,170
Watchman's family.....	13	84	92	292	2,400
Carpet dyer's family.....	16	71	93	310	2,430
Family of carver in a restaurant.....	13	85	88	261	2,235
Sailors' boarding house.....	17	95	125	181	2,295
Truckman's family.....	22	100	129	325	2,935
Sewing woman's family.....	9	54	41	219	1,500
Shopkeeper's family.....	15	80	109	351	2,780
Housekeeper's (widow) family.....	18	93	104	509	3,435
Laborer's family.....	23	139	119	345	3,090
Porter's family.....	28	142	142	444	3,720
Printer's family.....	22	116	124	364	3,120
Truckman's family.....	22	136	135	595	4,250
Family of caretaker at a day nursery.....	23	122	158	394	3,585
Builder's family.....	41	187	219	723	5,770
Do.....	42	204	264	714	6,220
Salesman's family.....	16	79	125	347	2,910
Tin roofer's family.....	20	99	123	327	2,910
Do.....	16	84	114	227	2,335
Family at a mission.....	37	143	205	545	4,725
Children at a day nursery (per child per day).....	4	30	20	120	800

From the data available the authors do not feel justified in drawing specific deductions. Some general suggestions for the improvement of the dietaries are, however, made. By the selection of cheaper though equally nutritious articles of food, it would as a rule have been

possible to supply a more nutritious diet at less cost. In many instances, while the foods chosen were inexpensive, they were of such a character that they contained a small percentage of nutrients. Purchasing in quantity, where possible, would also have diminished the cost. Some of the families studied had a sufficient income to enable them to live comfortably if care had been exercised in its expenditure. The

authors believe that permanent improvement must come through education. The people must be taught to select food wisely, and to cook it and serve it in an acceptable manner.

With these results may be compared the report on the dietaries of nine institutions of

*Calculated amount and cost of nutrients consumed per person daily.*

	Number of persons fed.	Cost.	Protein.	Fat.	Carbohy- drates.	Fuel value.
		<i>Cents.</i>	<i>Grams.</i>	<i>Grams.</i>	<i>Grams.</i>	<i>Calories.</i>
South Boston House of Correction.....	523	9.89	153	78	501	3,406
Deer Island House of Correction.....	1,754	7.34	122	69	624	3,700
Rainsford Island House of Reformation.....	125	8.07	103	60	414	2,677
Parental School.....	125	5.29	70	40	346	2,078
Marcella Street Home.....	333	8.37	95	55	380	2,459
Long Island Almshouse and Hospital.....	833	7.73	109	48	554	3,164
Charlestown Almshouse and Hospital.....	145	7.54	71	72	355	2,415
Austin Farm (inmates and employees).....	375	12.94	110	114	449	3,327
Pierce Farm (inmates and employees).....	194	18.85	138	180	471	4,171



the City of Boston, compiled by Ellen H. Richards and Sarah E. Wentworth (*Institutions Comm., Boston, Rpt., 1896, pp. 206-219*). On the basis of raw materials furnished and number of persons fed the above data were secured.

#### SCIENCE AND INDUSTRIAL SUPREMACY.

A RECENT writer in the *Revue des Deux Mondes*, M. Raphaël-Georges Lévy, draws a comparison between the chemical industries of Germany and France which is greatly to the disadvantage of the latter, says the *British Medical Journal*. Thus it is stated that the total annual European production of coal-tar derivatives reaches the value of 125 million francs. This is divided up in the following proportions: Germany, 90 millions; Switzerland, 16 millions; France, 10 millions, and England, 9 millions. A single factory at Ludwigshafen employs more technical chemists than are working at the same branch in the whole of England, while the attempts at organized teaching of technical chemistry here have hitherto been ludicrously inadequate. This is wherein our defect mainly lies. The industrious Teuton fastens upon the discoveries of chemists and physicists, and extracts from them the maximum of practical utility. Thus the secret of the aniline dyes was discovered in England; France took up the investigations; but it was in Germany that particular attention was first paid to their mercantile perfection as regards brilliancy, permanence and cheapness. As a natural result, Germany now almost monopolizes their production. The same is true in respect of electricity; the monetary benefit of the researches of Lord Kelvin and the late Professor Clark Maxwell is mainly reaped by the Allgemeine Elektrische Gesellschaft, and the great firms of Siemens, Loewe and Schuckert, which have a combined capital of over 15 million pounds. Almost the only chemical industry which holds its own in England is the manufacture of alkali, and this owes its success to a distinguished pupil of Bunsen's, Mr. Ludwig Mond. M. Lévy, in the article to which reference has already been made, points out that Bunsen and Liebig were the founders of German chemical industry. It was Liebig who devoted his energy and influence to obtaining

state aid for laboratories of technical science. From these laboratories issue annually some 800 doctors of science to undertake the direction of factories or the investigation of new products of commercial value. Their education has been assisted by the state, and the knowledge they have acquired will be devoted to increasing, by the surest of all means, the wealth of the nation.

#### GENERAL.

THE new observatory at Heidelberg, on the Königsstuhl, was dedicated on May 20th. Addresses were made by Professor Kehrer, Protector of the University, and by the Directors of the Observatory, Professors Valentiner and Wolf. The Observatory belongs to the State and is not a part of the University, but opportunities are offered to students for study and research.

THE Göttingen Academy of Sciences has received from the Emperor's special fund \$25,000 for gravity determinations in East Africa.

THE French Conservatoire Nationale des Arts et Métiers celebrated, on June 26th, the centenary of its foundation.

THE Physical-mathematical Section of the Berlin Academy of Sciences has made the following grants: 2,000 Marks to Professor Engler, of Berlin, for the continuation of his monograph on East African plants; 1,500 Marks to Professor Schultz, of Berlin, for the publication of a work on American Hektinellidæ; 1,000 Marks to Professor Brandt, of Kiel, to enable him to accompany the Prince of Monaco in his investigations in the Atlantic Ocean; 1,000 Marks to Professor Brueckhardt, of Basle, for investigations on the comparative anatomy of the brain; 1,000 Marks to Professor Kohen, of Greifswald, for the continuation of his investigations on meteoric iron; 600 Marks to Professor Graebner, of Berlin, for the continuation, of his investigations of the formation of the German heaths; 500 Marks to Dr. Kruger, of Charlottenburg, for investigations on the urine; 500 Marks to Dr. Küster, of Tübingen, for his investigations for the coloring matter of the blood and bile; 500 Marks to Dr. Loesner, of Berlin, for the completion of a monograph on the Aquifoliaceæ; 5,000 Marks to Dr. F. Ristenpart, of Kiel, for preliminary studies for

a 'Thesaurus positionum stellarum fixarum;' 1,000 Marks to Dr. Adolph Sauer, of Heidelberg, for the geological investigation of the Aar region; 1,000 Marks to Dr. Schellwien, of Königsberg, for an investigation of the Paleozoic Eastern Alps.

M. FOUQUÉ, professor of 'the natural history of inorganic bodies' in the Collège de France, has been elected a foreign member of the Vienna Academy of Sciences.

OXFORD UNIVERSITY has given the honorary degree of D.C.L. to Sir John Kirk, F.R.S., known for his administrative work in Central Africa, and to F. C. Penrose, F.R.S., the archæologist.

A PORTRAIT of Robert Brown has been presented to Kew Gardens by the Bentham trustees.

PROFESSOR FERDINAND COHN, the eminent botanist, died suddenly at Breslau, on June 25th, of heart disease. He was born in 1828, and obtained a chair of botany at Breslau University in 1859. He was the author of a well-known work entitled 'Die Pflanze.' He had made important contributions to bacteriology, and he wrote a book on 'The Development of Microscopic Algæ and Fungi.'

THE *Akademische Revue* reports the suicide, in Comfort, Texas, of Dr. A. Böcking, formerly privat-docent for zoology at Bonn, and known for his explorations in South America. Dr. Böcking had, however, for many years, given up scientific investigation and appears to have suffered many hardships during his life in the West.

DR. GÜMBEL, professor of geology, died at Munich, on June 18th, aged seventy-five years.

WE called attention to the program of the first Scientific Congress of South America, which was opened at Buenos Ayres on April 11th. We have not received any account of the proceedings of the Congress, but it appears from a brief notice in the *Lancet* that it was highly successful, being attended by some 600 delegates, representing all the countries of South America.

A CONFERENCE of peers, members of Parliament and representatives of associations interested was held in one of the committee-

rooms of the House of Commons on June 23d, on the initiative of Mr. Bryce and Mr. Boulnois, to consider the desirability of making some permanent arrangement for concerted action upon questions relating to: (a) the protection of rural scenes and landscapes and town prospects from such disfigurement or repairment as is not justified by considerations of public utility; (b) the provision and maintenance of commons, open spaces, public parks and gardens; (c) the preservation of buildings and places which are of peculiar interest by age, beauty or association, whether historical or literary; (d) the conservation of wild animals and plants; and generally for 'asserting the importance, on broad grounds of public policy, of maintaining beauty, simplicity, dignity and interest in the aspect of out-of-doors Britain.'

THE Italian government has receded from its action of forbidding foreign physicians to practice in Italy unless they acquire a diploma from an Italian university, to the extent of permitting them to treat their own countrymen.

ATTENTION has been called to the fact that plumes worn in the British army are a cause of the destruction of birds. In answer to Sir J. Lubbock, Mr. Brodrick said recently, in the British House of Commons, that orders have been given that plumes composed otherwise than of so-called 'osprey' feathers shall be prepared with a view to obtaining the sanction of Her Majesty to the abolition of the 'osprey' plumes worn by the commissioned officers in certain regiments. The selection of a satisfactory substitute is difficult, and some delay may occur in effecting the change.

MR. EDWARD STANFORD, London, has published a relief map, prepared by Mr. James B. Jordan, representing an area of 320 square miles with London as the center, in a horizontal scale of one inch to a mile and a vertical scale of one inch to 1,000 feet. The map is made of a stamped steel plate, and is said to be the first attempt to produce topographical models in this manner.

It is stated in the *Auk* that Mr. and Mrs. Herbert H. Smith, well known as expert natural history collectors, through their labors in Brazil, the West Indies and Mexico, are now in

northern Colombia, with several assistants, working under the joint auspices of the Carnegie Museum of Pittsburg, Pa., and the American Museum of Natural History of New York City. Mr. Smith and his party will give special attention to insects, birds and mammals, and will probably remain for a long time in the field, visiting other portions of northern South America after completing their work in Colombia. Messrs. Outram and E. A. Bangs have also an experienced collector, Mr. W. W. Brown, Jr., in the Santa Marta region of Colombia, from whom they have recently received considerable consignments of birds and mammals, preliminary notices of which have already begun to appear. Mr. George K. Cherrie, known for his work in Costa Rica and San Domingo, has been for some months engaged collecting birds and other specimens for the Hon. Walter Rothschild, in the Orinoco districts of Venezuela, where also the brothers Samuel N. and Edward Klages, of Crafton, Pa., have recently established themselves for natural history exploration, partly under the auspices of the American Museum of Natural History. While they will give their attention primarily to insects, a portion of their time will be devoted to birds and mammals.

THE Report of the Missouri Botanical Garden for 1898 contains two papers by Mr. J. B. S. Norton. In the first of these, entitled 'A Coloring Matter found in some Borraginacæ,' it is stated that in 1897 a small borage, which proved to be *Plagiobothrys Arizonicus*, was sent to the Garden from New Mexico, with the statement that the sheep feeding on it have their muzzles dyed of an intense red color. On further examination of the plant it proved to be alkannin, a dye produced by a number of borages, several of which are commented on in the paper. The second paper, 'Notes on some Plants Chiefly from the Southern United States,' is an account of an examination of material contained in the herbaria of Joor and Jermy, and a number of smaller collections from the Southwest. Mr. Norton has found species of phanerogams which are believed to be new, which he describes and figures in the article.

THE same Report contains an article by

Charles Henry Thompson on 'The Species of Cacti Commonly Cultivated under the Generic Name *Anhalonium*.' These cacti have of late years come into considerable popularity in the collections of amateurs. Mr. Thompson divides them into two genera, *Ariocarpus* and *Lophophora*, the former including what are commonly known as *A. fissuratum*, *A. sulcatum*, *A. furfuraceus* and *A. prismaticum*, while the latter includes what are sometimes treated as two forms or varieties of a single species and sometimes as two species under the names *A. Williamsii* and *A. Lewinii*. A simple key and half-tones prepared from photographs of living specimens render the determination of all of the species quite easy.

COMMENTING on the Annual Report of the Field Columbian Museum in an editorial, *Natural Science* says: "We should like to ask why it is that reports which come to us from American museums are always interesting to read, in strong contrast to the reports which come from most similar establishments in our own country and in Europe. It would seem that the writing of these reports is a labor of love to the Americans, while our own curators only do it as a piece of official routine. The consequence is that, in the present Report, as an example, the curator finds hints, suggestions and actual information of value to himself; whereas the Report of, say, the British Museum, contains little but lists of donations and the numbers of specimens registered during the year, with similar matter of no use to anybody in the wide world.

A REUTER telegram from Tromsø says that Mr. Walter Wellman, the American explorer, left on June 27th on board his ice steamer *Frithyof* for the North Polar regions. Just before his departure from England Mr. Wellman gave to Reuter's representatives an account of his expedition, in which he said that his aim was to reach the North Pole, and also to explore the still unknown northern parts of Franz Josef Land. The party consists of James H. Gore, Columbian University, a geodesist; Lieutenant Evelyn B. Baldwin, who was on the Greenland ice cap with Lieutenant Peary; Dr. Edward Hofma, naturalist and medical officer;



and Mr. Quirof Harlan, physicist, from the United States Coast and Geodetic Survey. Norwegians experienced in Arctic work make up the remainder of the party of ten. Mr. Wellman proposes to reach the Pole by a sledging expedition over the pack ice. At Archangel 75 sledge dogs, procured in Siberia, will be taken on board. At Cape Flora, on the southern coast of Franz Josef Land, two or three men will be left, while others will search for Andrée before the steamer returns in August. Half-a-dozen of the party, with small canvas boats, sledges and dogs, are to push on at once for the northern parts of the archipelago, passing successively the point reached by Mr. Jackson, the spot where Dr. Nansen and Lieutenant Johansen wintered, and Cape Fligely, lat. 82°, reached by Payer in 1874. Somewhere beyond 82° they intend to build a hut to winter in, shooting polar bear, seal and walrus for food. Next spring they propose to set out on a sledge journey toward the Pole. If the conditions are unfavorable they will wait till the second spring. They will have about 120 days in which to reach the Pole, if possible, and return to the land, requiring an average travel of nine to ten statute miles per day. They take with them a rubber pneumatic boat, which inflates with a pump like a bicycle tire, and also a folding canvas boat, built on Mr. Wellman's designs, also sledges of metal, water-tight, so built that they may turn over and over in rough ice or float in the water without injury to their contents. Each dog is to draw one sledge, practically without assistance or driving by the men.

At a meeting, on April 26th, of the select committee of the British House of Commons, on the Department of Science and Art, Sir J. Norman Lockyer was the principal witness examined. He, as reported in the *London Times*, spoke of the insufficiency of the present collection of scientific objects, having regard to the growing necessity of, and demand for, scientific teaching. The Royal College of Science, he pointed out, only taught pure science. The various applications of science to industry were not represented in their teaching at all, and therefore it was not part of their function to make recommendations with

regard to this large area of possible museum representation. He was perfectly aware that there was scarcely any branch of applied science which was not represented, more or less, in the present collection, but what he said was that the schemes of representation were very dissimilar and must necessarily remain so. He desired a considerable extension of the science collection. To him it was unthinkable to separate the schools from the museums. It was a much better education for the student of science to be turned into a laboratory, where he could use the apparatus and see other people use it, than to attend lectures. He had taken very great interest in this matter, and some amount of trouble, because it seemed to him that the truth of what Professor Huxley used to preach was coming home to them more and more every day. That was that they were in front of an industrial war, the result of which would be far more serious to them than a mere national war. In this industrial war it was no longer a question of battleships and cruisers. It was a question of schools. The schools were Germany's battleships; they in England had only cruisers. So far as the British fleet was concerned, it was supposed to be twice as strong as the fleets of any two Powers. That might be so, but educationally they were scarcely on a level with Switzerland. They could not hope to fight this struggle for existence unless they had battleships, by which he meant thoroughly developed scholastic institutions.

#### UNIVERSITY AND EDUCATIONAL NEWS.

REPORT OF THE COMMISSIONER OF EDUCATION  
FOR THE YEAR 1896-97.

THE first volume of the report of the Commissioner of Education for the year 1896-97 has been published. The Commissioner, Dr. W. T. Harris, in his summary, states that 16,255,093 pupils were enrolled in the schools and colleges, being an increase of 257,896 over the preceding year. This increase was entirely in public institutions, there having been a decrease in the total number attending private schools. The Commissioner attributes this decrease to the continuance of what is called 'hard times,' but it seems rather to be due to the improvement of public institutions. Twenty years ago there



were three times as many students in private high schools as in public high schools, whereas now there are more than three times as many students in the public high schools as in the private high schools.

The number of students pursuing liberal studies in colleges and universities was 97,122, a decrease of 255 from the number reported in the preceding year. The number of graduate students is, however, constantly increasing, being in 1896-7 4,919, of whom 1,413 were women. There were 8,173 students of theology, 10,449 students of law and 24,377 students of medicine.

Dr. Harris is especially interested in the introduction of reindeer into Alaska, and describes in some detail what has been accomplished in this direction. He thinks that the reindeer are useful in training the natives as herders and teamsters and in educating them in habits of thrift, which seems considerably to enlarge the scope of the Commission of Education.

This first volume contains 22 special papers of considerable though of unequal value. One of the longest of the articles (158 pp.), entitled 'Some Recent Contributions of Biology, Sociology and Metallurgy to the Curriculum of Colleges endowed by the Federal Government for the Benefit of the Agricultural and Mechanic Arts,' and written by Mr. Wellford Ad- dis, contains rather a curious collection of miscellaneous information. One of the more interesting articles is on college admission requirements, showing the great and needless diversity in our 475 institutions. The requirements vary from those of Harvard and Johns Hopkins down to the college that happens to head the list, which asks for entrance to a course for the A.B. : 'Lessons in English, elementary history of the United States, elementary arithmetic, geography and drawing.' In no department are the entrance requirements so generally unsatisfactory as in science. Could not the A. A. S. and the N. E. A. appoint a joint committee that would propose a remedy?

#### GENERAL.

A NEW Museum of Archæology for the University of Pennsylvania is being erected at a

cost of about \$500,000. It was begun in January of the present year and will be completed early next year.

GEORGE A. FOWLER, of Kansas City, has given \$21,000 to rebuild the agricultural buildings of the University of Kansas, recently destroyed by fire.

THE Rev. Robert Herbert Story, D.D., professor of church history in the University of Glasgow, has been appointed Principal of the University, in room of Principal Caird, resigned.

REV. JOHN WHITNEY has been installed as Rector of the Catholic University of Georgetown, D. C.

WILLIAM DUANE, PH. D. (Berlin), has been appointed professor of physics in the University of Colorado, succeeding Professor W. J. Waggener, who has resigned owing to failing health.

CORNELL UNIVERSITY has recently been called upon to contribute an unusual number of the members of her instructing staff to other institutions. This has been a particularly trying year in her technical and especially her engineering departments. The Sibley College of Mechanical Engineering, for example, loses the senior assistant in its electrical engineering department, Mr. Macomber, who goes to the Armour Institute, of Chicago, as professor of that branch; the senior assistant in the department of machine design, Mr. H. D. Williams, retires to promote a line of his own inventions of promise and importance; the next in seniority in the same department, Mr. A. T. Brûgel, goes to the Pratt Institute, to take charge of similar work there; two or three others, instructors, retire to find advantageous appointments elsewhere, while, in the department of experimental engineering, also, the instructor in the study of the 'materials of engineering,' Mr. Houghton, resigns to accept the professorship of mechanical engineering in the Arkansas State University. A number of these positions are, at last accounts, unfilled, and it is expected that special care will be taken to select men of practical experience, as well as of talent and education, to carry on work which is, in all cases, greatly specialized. This training of

young men to special work, usually preparatory to their early promotion into professorships elsewhere, is found, it is reported, to be somewhat trying to the heads of departments, as compelling too frequent changes; although it is most creditable to the college and very helpful to the growing technical schools and college departments into which this output passes.

THE Association of Collegiate Alumnae has awarded its European Fellowship to Miss Caroline Stewart (A.B. Kansas University '92, A.M. Michigan '95). Miss Stewart held a Scholarship in Germanic languages at Bryn Mawr, in '95-6, and a Fellowship at the same College in '97. The American Fellowship has been awarded by the Association to Miss Caroline E. Furness, Vassar '91, who has been assistant the past three years in the Observatory at Vassar.

THE Women's Education Association of Boston, which awards its Fellowships through a joint committee composed of members of its own organization and the Fellowship Committee of the Association of Collegiate Alumnae, has this year awarded two European Fellowships of \$500 each. The successful candidates are Miss Louise Phelps Kellogg, Wisconsin '97, student in American history; and Miss Katherine B. Davis, Vassar '92. Miss Davis was in charge of the Model Workingmen's Home at the World's Fair and was for a time head-worker at the College Settlement in Philadelphia. The past year she has held a Fellowship in Political Economy at Chicago University, and declined a reappointment to accept this Foreign Fellowship.

A PUBLIC meeting was held in Birmingham on July 1st, to consider the proposal of establishing a university in Birmingham. The principal address was made by Mr. Chamberlain, M. P., who strongly advocated the plan, and the following resolution was carried: "That, in the opinion of this meeting, it is essential that, in the interests of the city and the Midland districts generally, a university should forthwith be established in Birmingham." The resolution was carried. Donations were announced to the amount of £95,244. Included in this was £20,000 from the Birmingham,

Brewers' Fund, an anonymous donation of £20,000, £10,000 from Mr. G. H. Kendrick, five donations of £5,000 each, two of £2,000 each, and 21 of £1,000 each. Mr. Chamberlain was amongst those who gave £1,000.

SIR WILLIAM FORWOOD, Chairman of the Library, Museum, Art and Technical Instruction Committee of the Liverpool City Council, laid, on July 1st, says the London *Times*, the foundation-stone of an addition to the fine range of buildings (the Brown Library and Museum, the Picton Reading-room and the Walker Art Gallery) on the north side of William Brown-street in that city. The new structure, which is estimated to cost the corporation close upon £100,000, will provide additional needed accommodation for the Museum (which will then be one of the finest of its kind in the kingdom), besides the Central Technical School. The three lower floors, reached from a separate entrance in Byrom-street, will be devoted to the purposes of the Liverpool School of Science, Technology and Art. In the basement will be rooms for practical instruction in electricity, engineering and various other technical subjects. Above this will be a lecture-hall, capable of accommodating nearly 400 students, besides class rooms for various subjects, and the necessary administrative offices. On the floor above this again will be a number of other class-rooms, adapted for the instruction in mathematics, building construction, etc.; and in a cross gallery on a higher level (isolated from the other portion of the School) will be a properly equipped chemical laboratory and lecture-room.

THERE are this summer 5,606 students matriculated at the University of Berlin, which is more than 1,200 in excess of the registration last summer. There are in addition 678 auditors, of whom 193 are women.

#### SCIENTIFIC LITERATURE.

*L'Electro-Chimie: Production électrolytique des composés chimiques.* Par AD. MINET.

This little volume comprises two sections. Forty-two pages are devoted to the description of the electrolysis of sodium chloride. Every point of interest to manufacturing chemists is carefully considered and explained in detail.

Methods of preparing the chlorates of sodium and potassium, of purifying aluminium sulphate, of manufacturing persulphates, alkali bichromates, potassium permanganate, sodium hyposulphite, white lead, vermilion, etc., in the electrolytic way, are placed before the reader in a most attractive manner, so that as we proceed we are inspired with a desire to repeat these experiments, but having previously carried out similar schemes for most of the substances mentioned we find pleasure in corroborating the statements of the author, with an invitation to others to embark in this field of investigation.

The second section considers the application of the current to organic substances. The author credits Davy with having been the first chemist to venture into the field, but adds that Kolbe, Wurtz, Bourgoin, Walker, Miller, Weems, Berthelot and others made researches in this direction. Your reviewer would include the name of Mulliken in this list. The efforts of these men, bestowed upon the aliphatic acids and their salts, have been most fruitful, but the author of the work before us is content, and naturally enough, to give certain generalizations and deductions from the pen of Bourgoin, and then branches forth upon the synthesis of alcohol by Lapeyriere in 1880, with brief mention of that of Eisenmann, the decolorization of bark liquors, electrolytic tanning, etc. This section may be said to be entirely technical, but it, as well as the first section, merits the attention of chemists generally, for both contain much valuable matter, concisely expressed and highly suggestive.

EDGAR F. SMITH.

*Electro-Metallurgie.* Voie humide et voie sèche.

Par AD. MINET. Paris, Boulevard St. Germain, 120, Masson et Cie.

The author first defines electro-metallurgy, describes different types of electrical apparatus, and reviews the various laws relating to electrolytes, then outlines the precipitation of copper, lead, silver, bismuth, cadmium, mercury, gold, platinum, iridium, tin, antimony, iron, nickel, cobalt and zinc, giving with each the most suitable composition of bath, the proper current density, the regeneration of the liquors

and other data valuable to those engaged in electroplating.

The second section of the book, devoted to electro-metallurgy in the dry way, is most interesting. The metals considered are aluminium, magnesium, sodium, potassium, lithium, calcium, strontium, barium and zinc. A short historical sketch precedes the working conditions laid down for each metal. Taking aluminium as an example, there first appears a general outline for its isolation from the double fluoride of aluminium and sodium; then follow a description of the methods proposed by Minet, Heroult and Hall, with directions as to choice of electrolyte, including its physical properties, as well as the mode of regeneration, and also the electromotive force necessary for the decomposition of the various salts, and hints as to the nature and shape of the vessel intended to carry the electrolyte.

Students of chemistry will read this section with pleasure and profit, and lay aside the volume with the conviction that it brings little which can be criticised and a very great deal which will be helpful to all who wish to pursue this line of study further.

EDGAR F. SMITH.

*A Manual of Quantitative Chemical Analysis.*

By E. F. LADD, B.S., Professor of Chemistry in the North Dakota Agricultural College, and Chemist to the Government Experiment Station, Fargo, N. D. New York, John Wiley & Sons. 1898.

"This little manual is intended for the use of beginners in quantitative analysis. The methods have been selected to advance the student from the simple analysis to the more complex and difficult, and when he has completed the course as laid down here he will be in a position to intelligently use and interpret the advanced works of Fresenius, Crookes and the *Encyclopædias*." A book which will give a few simple examples illustrating the principles of analytical chemistry can be used with advantage by those who only wish a general idea of chemistry; but it is doubtful whether such a book is useful to one who expects to go more deeply into the subject. He would either have a very slight knowledge of the subject or would have to repeat the work in a more thorough manner.



The first part of this book is given up to analyses of single constituents, while farther on the student is given methods of analyzing food, water, urine and soils. It is impossible to treat these subjects satisfactorily in a few pages, and the mere mechanical analysis of a few of these products would prove of little value to one who might have to deal with related substances. The chief objection to the book might be summed up in the statement that it is too mechanical.

J. E. G.

*The Study of Man.* By ALFRED C. HADDON, M. A., D. Sc., etc. New York, G. P. Putnam's Sons. 1898. Illustrated. Pp. 410. (The Science Series; Edited by J. McKeen Cattell and F. E. Beddard.)

In examining Dr. Haddon's work it is just to bear in mind that he does not present it as a treatise on anthropology or its methods, but merely a collection of samples of the way in which parts of the subject are studied. It is 'not intended for scientific students,' but for the amateur and the general reader.

It may be pardoned in a reviewer who has followed with admiration Dr. Haddon's thorough ethnographical work to express a sense of regret that the author did not choose a severer model and a higher intention than he has acknowledged in these words. What the 'study of man' needs more than anything else just now is a series of comprehensive text-books, setting forth the methods pursued, the results attained, and the fields of future investigation adopted by and included in the general term Anthropology. It would be possible to write these in a form not repellent to the general reader and yet meeting fully the requirements of the student. It was the error of the series commenced publication by the Appletons that it drifted into small monographs, well enough in their way, but of slight educational value; and education in anthropological matters is what is most lacking at the present epoch.

Returning to Dr. Haddon's 'samples,' the inventory of them includes specimens mainly from two departments of anthropology, somatology and folk-lore. They are the two extremes of the anthropological curriculum, and

perhaps for that very reason were chosen. In the former he discusses in a pleasant way the principal measurements in anthropometry, Bertillon's methods, skull-indices, the color-scale in hair and eyes, and the form of the nose. A chapter is devoted to Dr. Collignon's admirable monograph on the ethnography of the Dordogne district. Others take up the evolution of the cart and the origin of the Irish jaunting car.

The latter half of the book is devoted to games and toys, those of children, savages and grown-up people. This is a comparatively recent field of research, and its fruitage promises to be of much greater value than was imagined by the earlier writers. Games are frequently the survivals of sacred ceremonies, and are peculiarly tenacious of early forms and expressions. Of the subjects under this head considered by Dr. Haddon the more important are kites, tops, the bull-roarer, and singing, courting and funeral games. Concerning all of them he collects interesting material and adds to it from his personal observations.

In his last chapter the author reprints the directions of the committee 'to conduct an ethnographical survey of the United Kingdom' appointed by the British Association in 1892, with additional practical suggestions of his own. A thorough index closes the volume.

The illustrations are sufficiently numerous, and include ethnographic maps of England and France, types of skulls, noses, etc., illustrations of vehicles, and of various cards and toys. They are well printed, and the manufacture of the book in general may be commended. As the first number of the 'Science Series' it will be welcomed as a promising contribution to the higher department of popular literature.

D. G. BRINTON.

#### SCIENTIFIC JOURNALS.

*The Astrophysical Journal* for June, which opens the eighth volume, contains as usual a series of important articles. In the first of these by Professor T. N. Thiele, of the Copenhagen Observatory, discusses the resolution into series of the third band of the carbon band-spectrum. Professor Michelson contributes a further account of his Echelon spectroscope, to which we have already called attention. Notes on the



Zeeman effect from the physical laboratory of Johns Hopkins University are contributed by Messrs. Ames, Earhart and Reese. Other articles are by Professor C. Runge, of Hannover; Mr. W. H. S. Monck and Mr. L. E. Jewell.

THE July number of *The Psychological Review* opens with an article by Sig. Gustavo Tosti, discussing the fields and inter-relations of social psychology and physiology. Professor J. H. Hyslop contributes an article entitled 'Psychical Research and Coincidences,' in which he shows that individual cases of premonition may be explained by normal processes of mind. Professor Chas. H. Judd treats the visual perception of the third dimension. There are shorter articles by Professor Caldwell, on 'Professor Titchener's View of the Self;' by Dr. MacDonald, on 'A Temporal Algotometer;' by Professor Baldwin, on 'Social Interpretations;' and by Professor Cattell, criticising Professor Münsterberg's article on the 'Danger from Experimental Psychology.'

THE *American Journal of Physiology* issued on July 1st contains the following articles: 'On intestinal Absorption and the Saline Cathartics,' by George B. Wallace and Arthur R. Cushny. 'The Movements of the Food in the Esophagus,' by W. B. Cannon and A. Moser. 'A Contribution to the Chemistry of Cytological Staining,' by Albert Mathews. 'Notes on *Cetraria Islandica* (Iceland Moss),' by Ernest W. Brown Ph.D. 'Variations in the Amyolytic Power and Chemical Composition of Human Mixed Saliva,' by R. H. Chittenden and A. N. Richards, B. A. 'The Venometer Nerves of the Hind Limb,' by F. W. Bancroft. 'An Analysis of the Action of the Vagus Nerve on the Heart,' by L. J. J. Muskens. 'A New Method for the Study of the Isolated Mammalian Heart,' by W. T. Porter.

The *Open Court* for July contains as a frontispiece a portrait of Lobachévsky taken from the bronze statue placed recently in the square now bearing his name, facing the University at Kazan, and the number contains an interesting account of the great geometer by Professor George Bruce Halsted.

Under the title 'The Fastest Vessel Afloat'

Mr. Cleveland Moffett describes, in the July number of *McClure's Magazine*, the 'Turbina' and a trip upon it in which the extraordinary speed of 40 miles an hour was attained. The writer holds that the Turbine engine will revolutionize steamship travel where there is a plentiful supply of coal.

#### SOCIETIES AND ACADEMIES.

TORREY BOTANICAL CLUB, MAY 10, 1898.

THE first paper, by Dr. Arthur Hollick and Mrs. Elizabeth G. Britton, was entitled 'A Description of a new Fossil Moss from Seattle, Washington, collected by Professor I. C. Russell.' The paper was read by Dr. Hollick, who also exhibited the original specimen, a fragment sent to Mrs. Britton for identification by Professor F. H. Knowlton, of the National Museum in Washington. Professor Knowlton supplied the following facts: "The specimen was collected by Professor I. C. Russell in July, 1897, near Cle Elum, Kittletas Co., Washington, and occurs in the Roslyn sandstone; its age is probably lower Miocene or Upper Eocene. It is associated with species of *Lygodium*, *Ulmus*, *Planera*, and a number of other beautifully preserved leaves. It is in any case the oldest undoubted moss thus far found in this country. The so-called *Hypnum Haydeni* of Lesquereux is with little doubt a *Lycopodium*." The specimen represents only the tip of a branch, about one-half inch in length; it is sterile and has been compared with figures and descriptions of other fossil American mosses, and differs from them all. It is undoubtedly a new species of the *Hypnaceae*, probably a *Rhynchostegium*, and will be named for its discoverer, Professor Knowlton.

Dr. Hollick showed a drawing of the fossil species and also several drawings made from living species which it most resembles. None of these, however, are exact equivalents.

In the discussion following, it was remarked by Mr. Hollick that fossil mosses are extremely rare. All specimens known are Tertiary or later, one reported from a Carboniferous horizon being now thought doubtful; but the existence of mosses in Jurassic times is inferred from the existence of an insect then, the present repre-

representatives of which feed upon mosses. The only fossil moss heretofore recorded from the United States is Lesquereux's *Hypnum Haydeni*, now believed to be instead a species of *Lycopodium*. Fragments from the Pleistocene have been reported from Canada. The species described this evening is probably the first distinct American species. Thirty or more foreign fossil *musci* have been described, many of them members of *Hypnum*, many of them of *Harpidium* and of *Sphagnum*. To this genus *Sphagnum* belongs the only fossil moss as yet known in fruit, a Tertiary specimen preserved in brown iron ore.

Discussion followed regarding the reasons for the rarity of moss fossils, Dr. Underwood, Dr. Britton, Mrs. Britton and the Secretary participating. Dr. Hollick said that, besides the negative reasons presented by lack of extensive search and by the small size of the plant in question, an important reason for the scarcity of moss-remains is the fact that mosses do not shed their leaves. Small plant-remains in Carboniferous rocks occur not in place, but in débris. Were moss-leaves deciduous there would have been greater chance of their accumulation and preservation in such masses of driftage.

The second paper, by Dr. L. M. Underwood, was entitled 'The Species of *Botrychium* of the *B. ternatum* Group.' The paper, which will soon be published, was accompanied by numerous specimens and followed by discussion at length of the principal Eastern representatives, especially of *B. intermedium*.

Mrs. Britton followed with remarks on the Muhlenberg collection of mosses recently transferred from the Philosophical Society of Philadelphia to the Philadelphia Academy of Sciences. They are preserved exactly as Muhlenberg left them, even to the replacing of a knothole. The plants are wrapped in leaves torn from Testaments printed in Low Dutch. With each specimen is preserved the number he had originally given it, the number he had used in sending it to Hedwig, and the name given it by Hedwig.

The bulk of Muhlenberg's ferns went to Willdenow at Berlin.

Among the collections at the Academy of Sciences in Philadelphia, besides those of Schweinitz, Sullivan, Nuttall and Darlington,

is that of Pursh, whose herbarium is still a series of scattered sheets, neither mounted nor classified, but with labels supplied in his own hand.

Dr. Britton announced the recent purchase, by the N. Y. Botanic Garden, of the herbarium and botanical collections of Professor Lewis R. Gibbs, of Charleston, S. C., through his daughter, Miss Maria R. Gibbs. The herbarium of Elliott is in bad preservation and much of it gone entirely. The Gibbs herbarium is deemed of special value as illustrative of Elliott's plants.

EDWARD S. BURGESS,  
Secretary.

#### ENGELMANN BOTANICAL CLUB.

THE Club met on June 23d at the St. Louis Medical College, fourteen members present.

Mr. Walter Kirchner read a paper on fossil plants of Florissant, Colorado, and exhibited a number of specimens, several of them being new species.

Mr. J. B. S. Norton made a report of the field meet held at Cliff Cave, six miles south of St. Louis, on June 4th. The locality was a wooded ravine with limestone cliffs next the river and some upland woods. The woods may be characterized by *Hydrophyllum Canadense*, *Aralia quiquefolia* and *Carex latifolia*. The character of the limestone out-crop formation may be represented by *Celtis pumila*, *Dodecatheon media*, *Agave Virginica*, *Tecoma radicans*, the latter covering the cliffs. Specimens of the *Agave* with red spotted leaves very close to var. *tigrina*, and compound leaves of *Vitis cinerea*, were exhibited.

J. B. S. NORTON,  
Acting Secretary.

#### NEW BOOKS.

*Biological Lectures Delivered at the Marine Biological Laboratory of Woods Hole, 1896-7.* Boston, Ginn & Co. 1898. Pp. 242.

*The Play of Animals.* KARL GROOS. Translated by ELIZABETH L. BALDWIN. New York, D. Appleton & Co. Pp. xxvi+341. \$1.75.

*The Doctrine of Energy.* B. L. L. London, Kegan, Paul, Trench, Trubner & Co., Ltd. 1898. Pp. 108. 2s. 6d.

# SCIENCE

EDITORIAL COMMITTEE: S. NEWCOMB, Mathematics; R. S. WOODWARD, Mechanics; E. C. PICKERING, Astronomy; T. C. MENDENHALL, Physics; R. H. THURSTON, Engineering; IRA REMSEN, Chemistry; J. LE CONTE, Geology; W. M. DAVIS, Physiography; O. C. MARSH, Paleontology; W. K. BROOKS, C. HART MERRIAM, Zoology; S. H. SCUDDER, Entomology; C. E. BESSEY, N. L. BRITTON, Botany; HENRY F. OSBORN, General Biology; C. S. MINOT, Embryology, Histology; H. P. BOWDITCH, Physiology; J. S. BILLINGS, Hygiene; J. MCKEEN CATTELL, Psychology; DANIEL G. BRINTON, J. W. POWELL, Anthropology.

FRIDAY, JULY 22, 1898.

PROBLEMS OF BIOLOGY.

## CONTENTS:

<i>Problems of Biology:</i> PROFESSOR E. G. CONKLIN..	85
<i>Language Study:</i> PROFESSOR J. MARK BALDWIN .....	94
<i>The Work at the Biological Laboratory of the U. S. Fish Commission at Woods Holl:</i> PROFESSOR HERMON C. BUMPUS .....	96
<i>Zoological Notes:—</i>	
<i>Publications of the American Museum of Natural History:</i> F. A. LUCAS.....	96
<i>Current Notes on Meteorology:—</i>	
<i>The Climate of the Philippines; Sonnblick Verein; Notes:</i> R. DEC. WARD .....	97
<i>Current Notes on Anthropology:—</i>	
<i>Later Criminology; The Delusion of 'Atavism;' Origin of the Cliff Dwellings:</i> PROFESSOR D. G. BRINTON.....	99
<i>Scientific Notes and News:—</i>	
<i>Extension of the Weather Service; The Spectrum of Metargon; The British Government and Antarctic Exploration; Professor Koch on the Plague; General</i> .....	99
<i>University and Educational News</i> .....	107
<i>Discussion and Correspondence:—</i>	
<i>Substitutional Nervous Connection:</i> PRESIDENT C. L. HERRICK. <i>The Exhibition of Cetaceans by Papier Maché Casts:</i> DR. F. W. TRUE.....	108
<i>Scientific Literature:—</i>	
<i>Gray's Treatise on Magnetism and Electricity:</i> PROFESSOR JOHN TROWBRIDGE. <i>Bibliography of the Metallic Carbides:</i> H. C. B. REEVS on <i>Brown Men and Women:</i> PROFESSOR D. G. BRINTON. <i>Edridge-Green on Memory and its Cultivation:</i> PROFESSOR J. MCKEEN CATTELL.....	109
<i>Societies and Academies:—</i>	
<i>Academy of Natural Sciences of Philadelphia:</i> DR. EDW. J. NOLAN. <i>The Torrey Botanical Club:</i> EDWARD S. BURGESS.....	111
<i>New Books</i> .....	112

A BOOK entitled 'Problems of Biology' has recently been issued from the press of Swan, Sonnenschein & Co., which is in many respects remarkable. Its author, Mr. George Sandeman, is evidently a metaphysician whose knowledge of biology is limited largely to theoretical writings. His style is peculiarly obscure and incoherent; *e. g.*, the following is the preface: "This volume contains the criticism of the contemporary biological systems. That enquiry is necessary as an introduction to the study of the problems of organic life, but it is not in itself a doctrine of biology. The argument ought to proceed to the discussion of the philosophy of nature." There is a flavor of dogmatism, pedantry and extravagance about the book, and often one does not know whether the author is in earnest or is perpetrating a huge satirical joke. But, in spite of all these imperfections and uncertainties, there are many keen and just criticisms of certain popular biological doctrines and methods.

The contents are divided into five chapters, the first of which is a far-going criticism of the Methods of Biology. There is, we are told, a remarkable anarchy within the science as well as a certain indefiniteness in its scope. "The inner confusion of biology depends upon the form of the science. The *necessary* form is a theory of individuality. The *professed* form is the

MSS. intended for publication and books, etc., intended for review should be sent to the responsible editor, Professor J. McKeen Cattell, Garrison-on-Hudson, N. Y.



induction of general laws from known facts. The *actual* form is a certain product of these two factors. Each biological system has to answer two questions: How are the qualities of the individual related to one another? And, How do the qualities exist by reason of their significance?" The various systems are complete and final in themselves and are mutually exclusive. "There is complete independence of one another and almost complete independence of research. If it were not so they would combine and research would discriminate between them. There are twenty good theories of the development of the individual, but I cannot say that any one seems to be better or worse than all of the rest. A certain controversy with regard to natural selection and use inheritance lived long and was discussed in every public place and with the aid of hosts of detailed observations. Yet it was never cleared up and neither side had the advantage; but because men become weary of it, it has now been allowed to rest. It is not otherwise with the history of biology. New systems supersede old ones and the latter are not disproved but forgotten. \* \* \* These are some of the features of the inner confusion. They have made the very name of biology a by-word. And though the anarchy may not be obvious to a people delighting in formulæ which may be applied with equal facility and barrenness to everything which is organic, it is so present to men of research that they leave the whole matter on one side as simply not pertinent to their occupation, and are not patient to bear even the mention of what they repudiate with more justice than they are always aware, as metaphysics."

Such a criticism is plausible and misleading. In biology, as in other sciences, there is a field of well ascertained facts and of well grounded theories, and outside of this there is a region of hypothesis which, as in chemistry and physics, extends out beyond ob-

servation and experiment and thus enters the sphere of metaphysics. Because popular interest is so largely drawn to the borderland problems, our author seems to assume that the whole science is merely an aggregation of crude, pioneer hypotheses. It will astonish many persons to learn that the theories of biology are completely independent of each other and of research, that they cannot combine and that research cannot discriminate between them. There was once held a doctrine of preformation which taught that the homunculus existed *as such* in the egg or sperm. Does any one hold that view to-day? There was once an opposing doctrine of epigenesis which taught that the egg or sperm is *unorganized* matter. Does any one still hold this view, and has research had nothing to do in settling this famous controversy? This single instance, and many others could be cited, proves that what appear to be contradictory views may be harmonized when research has made our knowledge of the subject more complete; and in this biology does not differ from any other science. Other problems, though not absolutely settled by research, are out-grown and forgotten; we do not care to seriously discuss the *circuitus gallinaceus* to-day; the narrow limits of the old problem have been outgrown, and it is not otherwise with any science: "The old order changeth, yielding place to new." The ideas of many people are hazy as to the significance of the word *biology*; by some it has been regarded with suspicion; by others it has been used to conjure with, but who will not be surprised to learn that the name *biology* is a by-word? To be sure, it does have the same sound, but the spelling ought to save it.

Another subject of the author's criticism is the vagueness, ambiguity and self-contradiction of the most important terms and conceptions of biology; *e. g., function, acquired character, inherited character, etc.*



This criticism is especially applicable to the most general and inclusive terms of biology and of many other sciences. It is unfortunately true that many biological definitions are not as clear cut and consistent as they should be, but where a definition includes a great mass of little known phenomena nothing better can be expected; it would be ungracious on the part of the biologists not to be thankful to the philosophical critics for pointing out these inconsistencies, but the real remedy here, as in the matter of unsatisfactory hypotheses, lies not in criticism, but in exploring more thoroughly the facts and phenomena in question.

But leaving the general introduction and passing to the more specific criticism of the methods of biology, we are told that the actual form of theoretical biology is dependent upon three postulates: 1. "The qualities of the individual are discrete, numerable constituent elements of which the organism is the total sum, and have, therefore, each the value of an ultimate unit for biology. They are thus independent of one another as regards their significance, maintenance, development in the individual, existence when latent, inheritance and variation and acquirement by the race." 2. "The qualities of the organism and all its stages are the manifestation of, and are related to one another only through, an agent or system of agents within the known body. The agent which answers to the unity of the organism is purely self-determining; it is in the attitude of pure activity to the body, which in consequence is in the attitude of pure passivity to the agent. \* \* \* It carries the qualities when they are latent and carries alternative qualities, and it manifests these when and where they ought to be manifested." 3. "The adaptedness of organisms is due to the external addition of new qualities to the rest, which henceforward are included among, but not conditioned by, the qualities

which have up to that time existed. The environment is something separate from the organism; and the latter is, by the addition of new qualities to the trust of the agent, thus educated up to circumstances which can exist without it. The inertia of the agent is such that it may persist in presenting qualities which are unrelated to other qualities and which have ceased to have any special external and independent use. The various qualities of the organism are thus due to the slow addition of modifications through many years of changing circumstances."

At first thought it will be doubted whether any biological system makes any such radical demands as are contained in these three postulates; certainly few biologists are conscious of making such demands, and yet the author shows, with much ability and a wealth of illustration, that this is the logical outcome of many biological doctrines.

The book is almost entirely devoted to a philosophical criticism of these three postulates. This criticism is, in the main, clear sighted and well founded. After declaring that these postulates are not working hypotheses and in themselves are of no value to research, the author points out their weaknesses from the standpoint of philosophy. "The first and second postulates arise from the relativist theory of knowledge and the agent is the thing-in-itself \* \* \* The whole method depends upon a fiction; \* \* \* it is a mere logical fallacy. If biology is to treat of *individuality* we need a better form of doctrine than that of the agent." As to the third postulate, it presupposes the transformation of species, in favor of which doctrine the author sees but little direct evidence, though he feels compelled to accept it because of analogy with other systems.

I. In the second, third and fourth chapters the author deals at length with the

three postulates named. As to the first, he says that it is actually affirmed, or at least assumed, in many theories of general biology, of which the following are illustrations:

1. Nägeli, De Vries and many other biologists think it necessary to believe in separate, discrete and numerable hereditary units which exist in a kind of symbiosis in the organism. The qualities which are represented by these units may be morphological, physiological, latent, alternative, stages in development, etc.; in fact, every difference in the organism is to be distinguished as a separate constituent element.

2. This postulate is also closely associated with the cell theory, which has become unduly important under its influence. "It is possible to so insist on the multitude, on the similarity and on the independence of cells as to deny the supreme individuality of the body. The whole organism, it is said, is but a colony of these, the true individuals, and the secret of its form is to be found in their habits of growth, reproduction and differentiation. And so the question of the whole and the parts is removed from the sphere of the body, in which we have some opportunity of studying it, only to be repeated in the microscopic sphere of the individual cells. \* \* \* If the individuality of the body is to be slurred over we have a right to expect that some architectural principle should be found in the cell itself. \* \* But I find no such attempt to fill up the conception of cells as anthropomorphic agents. \* \* We are not likely to find within an individual abstracted from a system in which it is only an element, the principle of the architecture of the whole system. \* \* Myriads of miserable Egyptians carried stones to the Pyramids; but no microscopic watching of any of these, stone and all, would ever explain the Pyramid itself."

3. Another illustration of this first postulate is found in the doctrine of the

independence of parts, particularly put forward by Roux in his 'Struggle of the Parts.' "There must be some curious fascination about this conception of *struggle* that it should be introduced into the explanation of the parts of that which is the most perfect and unique unity we know."

4. The ordinary conception of independent variability of parts implies independence of qualities. If variations are really independent then we may at once give up the unity of the organism. The author argues that there is no such thing as independent variability, that all variations are correlated. Darwin's cases of correlated variations, viz., hairless dogs having imperfect teeth, white cats being deaf, etc., are only whimsical instances of a general law of correlation of parts. Natural selection, by insisting on independent variability, is unable to explain the numerous coordinated variations necessary to make the variation of a single part effective. The same difficulty is met, though to a less extent, by the advocates of use inheritance, for here also qualities are considered as primarily independent. "Confusion inevitably awaits any theory which moves by the disintegration of the individual into self-sufficient and primarily unrelated parts."

5. "This first postulate is further shown in the ordinary biological treatment of *functionless* parts, which are supposed to exist in their own right and in virtue of a separate inheritance. A functionless part of an organism is not useless; it is merely useless in a certain manner. \* \* \* Nothing organic is functionless, except for a certain special abstract point of view." Every part is in some way related to every other part, and the very fact that a structure exists at all is evidence that in the process of its origin, development and maintenance it is functionally related to other parts. "One is apt to hastily assume that the significance of the part to the individual has nothing to

do with its rise and maintenance in the individual, and this assumption, when it is generalized, becomes the law that structure precedes function in the individual development. The whole movement of thought is due to the attribution of a merely abstract and external significance to the part."

6. "The postulate of the independence of parts is further found in the biological treatment of *latent* and of *alternative* parts and qualities. \* \* \* The manifold features of the organism are latent in the germ; \* \* \* regeneration of lost parts is due to the existence of the necessary parts in a latent condition; \* \* \* all organic differences are inherited in latency and may vary when latent; \* \* \* each generation in alteration of generations contains the other in latent condition; each sex holds as latent the alternative characters to its own; every change which the species undergoes in new conditions was latent in it before. \* \* \* Latency is the chief category of biology. \* \* \* Now, whatever is latent is simply not there; it has no existence. \* \* \* Latency is possibility, and a thing is possible because of something else. And the problem of biology is to find a form for that *something else*. \* \* \* The biological treatment of latent qualities shows that they are looked upon as independent of the rest." Against this position the author urges the great number of possibilities open to an organism under varying stimuli. "There is much more latent in an organism than is ever actual at any one time, and if all the possibilities are separate things we must invent a form for them in which they can be present in infinite numbers within a microscopic cell." In his treatment of alternative qualities the author admits that latency is not the same as possibility, for here we have one of two perfect forms developed, which may be wonderfully adapted to each other, as, for example, in the two sexes. He concludes, as have all who have

reflected upon this subject, that it is necessary to assume some mechanism which will react in one of two definite ways. In treating of this subject his use of the word *Anlage* is unusual. "The *Anlage*," says he, "is not a thing which has ever been seen, but is that hypothetical object which represents the latent existence of one future particular." A glance at any text-book of embryology would show that a nascent, *visible* structure which has not yet the form and function of the developed part is frequently called the *Anlage* of that part.

7. Finally, this postulate dominates the doctrines of organic evolution; since each part exists in its own right, it is easy to imagine the putting together of this or that adaptation, the subtraction or addition of this or that part to any extent and in any combination that is able to survive.

In conclusion, the author affirms: "Organic differences of every kind are not separate elements; they are not numerable units, and the organism is not a mere sum of such units. To find that this is the case one has only to attempt to find one character in an organism which is not at once a part of a larger whole and itself capable of analysis into a hundred subordinate relations. \* \* \* However much we may appear to gain for biology by separating the organism into things which play upon one another externally, \* \* \* we really do no more than to do away with the individuality of a natural system in order to invest its parts with the more unique character of moral agents."

II. The second postulate, viz., that there is a self-determining agent within the known body, in which the unity of the organism inheres, is a necessary consequence of the first postulate, for as the latter breaks the organism up into separate and independent qualities so the former finds the unifying principle in the anthropomorphic agent. This agent is conceived under two different



guises: (1) as a material bearer or vehicle of the qualities; (2) as a quasi-psychical principle. The majority of biologists are advocates of the former view, among them Darwin, Spencer, Haeckel, Nägeli, DeVries, Wiesner, Weismann; the latter view has had numerous adherents from Bruno to Bunge, among them Stahl, Jaeger, Bunge and Hartmann.

With remarkable insight, the author criticises the theories of DeVries, Spencer, Weismann and Nägeli. The gist of this criticism can be given here in only a few fragmentary extracts. As to DeVries' theory of Pangenesis he says, after giving DeVries' point of view by various quotations from his work: "It seems fairly evident that we have to do with a metaphysical question alone, in all these quotations, just the question of identity in difference, of substance and quality. The pangenes are anthropomorphic agents, each one of which is a material vehicle of a special quality. They are anthropomorphic because they are purely self-determining and not passive, and because they know the right and do it. They become functional *when it is time for them to do so*; they slip out of the nucleus *when they are needed* outside; they go through the cytoplasm to that part of the cell *which requires* their quality."

An account of Spencer's theory of Physiological Units is then given and their contradictory qualities are pointed out. "The agents (units) are now similar to one another, and again dissimilar; they are now merely constitutive and again directing. The units are different when considered in relation to the differences of the body, but they are identical when considered in relation to the ideal identity of these differences. When a distinction is thus substituted for a vague self-contradiction the units themselves present that problem of the organism for the satisfaction of which they were invented. They have the two

aspects of identity and difference, and can no longer be the identity for the given differences of the body, so that they become useless."

Weismann's theory of the Germplasm is then briefly sketched, and in conclusion the author says: "Let us compare the determinant to an organism. Like the organism, the determinant can retain its proper form and functions and is the same determinant through all changes. It is fed; it reproduces itself. It is not homogeneous, but contains many ordered differences, and in virtue of its qualities it does its work. Now all its qualities are surely not the mere result of one another, for if they were it would not retain its identity through all the differences of its life any more than the organism would do if cells were conditioned by cells and stages by stages. You, therefore, need another system of determinants to control the determinants of Weismann as soon as anything is known about these, and to be the vehicles of their qualities; and you must then examine that new system in order to see whether or no you need yet another."

Nägeli's theory of Idioplasm is next considered, and it is shown that Nägeli regards the idioplasm as mere difference at one time and as mere identity at another, and finally that he considers it a quasi-psychical principle which brings forth *suitable* qualities at the *appropriate* time. Nägeli himself draws an analogy between the idioplasm and a pianist, and in this analogy the author finds a satisfactory summary of Nägeli's theory and a sufficient condemnation of it. "The *sounds* answer to the manifold differences of appearance; the *keys* to the idioplasm as mere differences; the *pianist* to the idioplasm as abstract identity; and, lastly, the *score* to the ideal unity in multiplicity. Now the analogy differs from the known body in one respect, that it inserts between the phenomenal differences and the



ideal unity, two steps; I mean the abstract difference of the keys and the abstract identity of the pianist. And Nägeli's theory, like all other theories of ontogeny, exists only in order to insert those two steps."

The author then proceeds to a consideration of the agent as a quasi-psychical principle, and as illustrating all doctrines of the class he chooses the theory of Bunge as set forth in his essay on Vitalism and Mechanism, in which there is laid down the familiar distinction between physical and chemical processes, on the one hand, and vital processes, on the other. "The former as *mechanical* are set over against the latter as *in some way not mechanical*, but as free from reciprocity and as conditioned only by ends. \* \* \* But we have no reason for excepting psychical *processes* from that form under which we include the rest of the organism. Thinking is not miracle any more than 'cerebration' is miracle, and as a process it is as much in bondage to necessity as anything else is. \* \* \* The *purposefulness* of the organic differences is that which has to be explained, but the two kinds of processes which are here distinguished do not differ in respect of that matter. Both are, if both exist, equally purposive in fact and equally mechanical in derivation. And all that the theory seems to do is to add to one set of processes another set which does not at all help us in the explanation of the former. \* \* \* An intelligence is, indeed, an identity in difference, and it is perhaps natural that we should seek to insert such an intelligence into the organism as the agent of its identity. But an intelligence is the unity of its own differences—its own states; there is no conceivable sense in which it should be unity for the parts of the body."

In conclusion, the author examines the various theories of the agent in their relation to fact and as to their characteristics as a method. As to their relation to fact he attempts to apply these theories to the

structure and functions of the Protozoa. What is the inner secret of the remarkable outer differences which are found in this group? "The agent here is of no avail, for you cannot divide up these creatures into separate cooperating cells nor regard their qualities as carried by vehicles. You cannot, in short, in their case delude yourself with the belief that individuality in organisms is a vain show due to the external action of an agent or system of agents upon the passive material which is known to us in research. \* \* \* I believe I am right in saying that *no explanation of the immediate existence of any morphological element has ever been made*. And this fact, veiled in the case of the Metazoa, because in their case an external significance for the structure can so easily be found or feigned, lies open to us chiefly in the case of the unicellular animals, in which we are at once forced to see that form must have its *rationale* and to confess that this *rationale* is hidden from us."

As to the general characteristics of the hypothetical agents the author observes: (1) that they are not known and have not been observed; (2) they are a scaffolding for the synthesis of abstract sciences; (3) they are alogical, and (4) they are unknowable. "In all these characteristics of the agent there is but one endeavor on the part of the theorists; it is to find an expression for the unity of the organism. But the method seems to me to be so riddled with contradictions as soon as it is taken seriously, and to be in any case so formal and inefficient, that we had better leave the whole problem alone than solve it by the empty doctrine of the independence of organic qualities and by the empty hypothesis of the anthropomorphic agent."

III. The third postulate is the basis for all theories of adaptation, whether they be those of evolution or of design. It proceeds from the assumption that "everything organic exists only by reason of, and is to

be explained only in relation to, some special use which it now has or which a similar structure has had in former times." As well might one say that grass was made for cows to feed on, or that day and night alternate that we may have light for work and darkness for sleep. If a special function cannot be assigned to a structure as its *raison d'être* it is commonly regarded in one of three ways: (1) the function has not yet been discovered; (2) the structure is necessarily involved in the structure of other parts which have a special function; (3) the structure is 'vestigial' and its special function has been lost, though the part itself is continued by force of inheritance. There are serious objections to assigning a special function to every part for the fulfilling of which the structure exists: in the first place, the special use is only one of many, and frequently not the most important one, which the part performs; secondly, the special use is merely conjectural, and which of the many uses it has is most important cannot be determined. It is impossible for conscious, reflecting beings to give a complete account of the causes of all their actions; much more must this be true of the uses of parts of organisms viewed objectively.

Three 'factors of evolution' are then considered, viz: Lamarckism, Use-inheritance, Natural Selection. Lamarck derives the adaptations of organisms from their needs. A certain confusion exists in his theory due to ambiguity in the use of the word '*besoin*,' which in some connections means *need*, in others *desire*. After quoting several important passages from the *Philosophie Zoologique*, the author says: "Now, all this doubtless appears very ridiculous, and, though it is as good as any theory of transformation, so it is. But it reveals one thing, a haunting sense on the part of Lamarck that he must bring in the conception of need at every point. These are no facts which he is relating to us; they are a set of

the most varied and confused fancies as to how *need* can bring about the adaptations of organic life. Of the fact that need effects all this he is well assured, but his knowledge goes no further. And he finds it extraordinarily difficult to imagine how the indispensable principle of his theory does its work. Sometimes that which is needed is represented as actually thought of by the animal, sometimes as merely present to its 'inner feeling,' and sometimes as belonging to the animal only in one respect—in that it would be well for the animal to have it, though it has it not. Sometimes the creature needs the particular structure because of other habits or structures which it has already, and which could not exist in fact without that which is represented here as derived from their need of it. In a word, the main principle of a biological system could not well be more formal and all-inclusive, or in its working-out more indefinite."

As to Use-inheritance the author at once denies the distinction between innate and acquired characters. He takes, as a basis of discussion, the definitions of these terms given by Delage in his work on Heredity, viz: "Innate characters are those which have been contained in the fertilized ovum in some form or other; whether that form is known or not matters little. Acquired characters, on the other hand, are those which have been developed only through the action of the surrounding conditions." But the innate characters cannot be present *as such* in the ovum; they must be there only as separate and unknowable agents, for if present only in the sense that they are *possible* we cannot distinguish them from acquired characters which are also possible. On the other hand, acquired characters must be represented in some form in the germ. If they are only modifications of innate qualities they are innate qualities which are usually latent. "And not only

are acquired characters innate in that they are possible to the germ (and that is the only innateness of which we know anything or can at all credit), but the innate qualities are also acquired. They are, to use Delage's own definition of acquired characters, developed through the action of surrounding conditions." Only through the action of surrounding conditions are characters of any sort developed.

"Everyone admits that the experiences of the parents will in some way or other affect the germ and, therefore, the offspring. Are these changes identical in kind with those changes of the parent which gave rise to them? \* \* \* The only method of exploring the question would be through the whole physiological history of the germ and of its development. \* \* \* It is absolutely necessary that we should know this intermediate germ form and how it relates to the soma whence it comes, as well as how it relates to the soma which springs from it, before we can say what degrees and kinds of effect the particulars of the parent have on the far other pattern of the particulars of the germ, and what degrees and kinds of effect the particulars of the germ have upon the particulars of the embryo."

The consideration of Natural Selection falls under two heads: (1) a discussion of the struggle for existence; (2) a criticism of Delage's objections to the doctrine. As to the struggle for existence the author maintains that in the Darwinian sense every relation of an organism, whether external or internal, may be regarded as a struggle. Species struggle with each other and with their environment, parts and organs struggle with each other, and unknowable agents with unknowable agents. "The mother struggles with her child for nourishment. All individuals of one sex struggle with one another for those of the opposite sex. Parents struggle for representation in their offspring, and even

forgotten ancestors, we are told, are separately within us, conflicting among themselves for another sight of the sun. In none of these cases do we see any struggle; we see merely results, and the struggle is a method of explaining them. \* \* It comes to be a question why we should speak of two things as *interfering with* one another, rather than as being *related to* or as conditioning one another in such and such a way. \* \* \* The struggle between species or between the members of a species being, as we understand, a conflict by means of all qualities which have external uses, it is no more a special phenomenon of natural history than the struggle between the members of my body is a fact of physiology. In either case we have to do with nothing more than with a merely general anthropomorphic expression for relation."

The author then discusses seven objections which Delage sets down against the adequacy of natural selection in species formation. He agrees neither with Darwin nor with Delage. The objections to the doctrine of natural selection are not as to details; they lie at the basis of the whole method. The question is not whether natural selection is an all-sufficient factor of evolution, as Darwinians maintain, nor yet whether it is a subordinate factor, as Delage maintains, but whether it is a factor at all.

The book concludes with a brief chapter on the 'Unity of the Organism.' It is argued in a very positive fashion that the unity of the organism cannot be found in the protoplasm; that it cannot be found in any agents supposed to reside within the protoplasm; that it cannot be found in unity of feeling or the immanent soul, and that it can be found only in the *character* as distinguished from the characteristics. "We can regard all particulars as manifestations and components of one character. That character may develop itself in the ontogeny, but it does not



change. It is the same in the simplicity of the germ as in the complexity of the image. It is identical under the differences of male and female. It is the common nature, though no common quality, of germ and somatic cell, and of the elements of the different tissues. Individuals which differ from one another differ by one difference which, however, cannot be described except as an infinite number of differences, and all the features of one individual are one character. This is not the character of the protoplasm, nor of the idioplasm, nor of the immanent soul, but of the whole creature. And this character is no cause or condition amongst others. It is an aspect of all and is that aspect by which all comes into unity."

As thus defined the character, and hence the unity, of the organism is a purely metaphysical conception, wholly removed from the possibilities of research, and for my part I cannot conceive how such a conception can in any way advance our knowledge of organisms or assist us in the study of vital processes.

The basis of the whole criticism is the first postulate, which, in one respect at least, is wide of the truth. This postulate asserts that the qualities of an organism are *absolutely* separate and distinct elements. This, no one I suppose, has ever explicitly assumed or believed. If it were granted that the qualities of the organism are not absolutely independent, that the elements of the germ are related to each other as are the parts of the adult, the foundations of much of the criticism would be removed. But even as it is, the book will serve a good purpose as pointing out certain dangerous tendencies in recent biological speculations, and it should be read by all those who are interested in such speculations or who are in danger of rushing into biological metaphysics. It is a pity that the book is divided into chapters only and that there are no

subordinate headings or numerical indices to indicate the subdivisions of the argument, and also that in many places the style is obscure, dogmatic and metaphysical, since with all these evident defects it will hardly obtain the reading which it otherwise deserves.

E. G. CONKLIN.

UNIVERSITY OF PENNSYLVANIA.

---

LANGUAGE STUDY.\*

FROM a general consideration of the child's training it becomes evident that the great subjects which are most useful for discipline in the period of secondary education are the mathematical studies on the one hand, which exercise the faculty of abstraction, and the positive sciences, which train the power of observation and require truth to detail. If we should pursue the subject into the collegiate period we should find mental and moral science, literature and history coming to their rights. If this be in the main psychological we see that language study, as such, should have no great place in secondary education. The study of grammar, as has been already said, is very useful in the early periods of development if taught vocally; it brings the child out in self-expression, and carries its own correctives, from the fact that its results are always open to social control. These are, in my mind, the main functions of the study of language.

What, then, is the justification for devoting ten or twelve years of the youth's time to study of a dead language, as is commonly done in the case of Latin? The utility of expression does not enter into it, and the discipline of truth to elegant literary copy can be even so well attained from the study of our own tongue, which is lamentably neglected. In all this dreary language study the youth's interest is dried up

\* Extract from *The Story of the Mind* in the press of D. Appleton & Co. (Useful Story Series.)



at its source. He is fed on formulas and rules; he has no outlet for invention or discovery; lists of exceptions to the rules destroy the remnant of his curiosity and incentive; even reasoning from analogy is strictly forbidden him; he is shut up from nature as in a room with no windows; the dictionary is his authority as absolute and final as it is flat and sterile. His very industry, being forced rather than spontaneous, makes him mentally, no less than physically, stoop-shouldered and near-sighted. It seems to be one of those mistakes of the past still so well lodged in tradition and class rivalry that soundness of culture is artificially identified with its maintenance. Yet there is no reason that the spirit of classical culture and the durable elements of Greek and Roman life should not be as well acquired—nay, better—from the study of history, archæology and literature. For this language work is not study of literature. Not one in one hundred of the students who are forced through the periodical examinations in these languages ever gets any insight into their æsthetic quality or any inspiration from their form.

But more than this. At least one positively vicious effect follows from language study with grammar and lexicon, no matter what the language be. *The habit of intellectual guessing* grows with the need of continuous effort in putting together elements which go together for no particular reason. When a thing can not be reasoned out, it may just as well be guessed out. The guess is always easier than the dictionary, and, if successful, it answers just as well. Moreover, the teacher has no way of distinguishing the pupil's replies which are due to the guess from those due to honest work. I venture to say, from personal experience, that no one who has been through the usual classical course in college and before it has not more than once staked his all upon the happy guess at the stubborn author's mean-

ing. This shallow device becomes a substitute for honest struggle. And it is more than shallow; to guess is dishonest. It is a servant to unworthy inertia; and worse, it is a cloak to mental unreadiness and to conscious moral cowardice. The guess is a bluff to fortune when the honest gauntlet of ignorance should be thrown down to the issue.

The effects of this show themselves in a habit of mind tolerated in persons of a literary bent, which is in marked contrast to that demanded and exemplified by science. I think that much of our literary impressionism and sentimentalism reveal the guessing habit.

Yet why guess? Why be content with an impression? Why hint of a 'certain this and a certain that' when the 'certain,' if it means anything, commonly means the uncertain? Things worth writing about should be formulated clearly enough to be understood. Why let the personal reaction of the individual's feeling suffice? Our youth need to be told that the guess is immoral, that hypothesis is the servant of research, that the private impression instructs nobody, that presentiment is usually wrong, that science is the best antidote to the fear of ghosts, and that the reply 'I guess so' betrays itself, whether it arise from bravado, from cowardice, or from literary finesse! I think that the great need of our life is honesty, that the bulwark of honesty in education is exact knowledge with the scientific habit of mind, and, furthermore, that the greatest hindrance to these things is the training which does not, with all the sanctions at its command, distinguish the real, with its infallible tests, from the shadowy and vague, but which contents itself with the throw of the intellectual dice box. Any study which tends to make the difference between truth and error pass with the throwing of a die, and which leads the student to be content

with a result he can not verify, has somewhat the function in his education of the puzzle in our society amusements or the game of sliced animals in the nursery.

J. MARK BALDWIN.

PRINCETON.

*THE WORK AT THE BIOLOGICAL LABORATORY OF THE U. S. FISH COMMISSION AT WOODS HOLL.*

THREE months ago the United States Fish Commission announced that its Biological Laboratory would be reopened; that it would be equipped for investigation; that men of science would be welcome, and that every effort would be made to collect all needed material, and to furnish, within certain limits, all necessary instruments and apparatus for research. The Station is the most extensive plant for the study of marine life and practical fish-culture in the world. There are four buildings: The Hatchery, Laboratory and Aquarium; the Residence; the Shops and Store House; and the Power House. It is in possession of a small fleet of steam and sailing vessels, and by special enactment the officers are empowered to use, at their discretion, any means for the capture of fish or other marine organisms.

The Commission has refurnished the Biological Laboratory and added ten new rooms for research. It has equipped a laboratory for physiology. It has purchased a bacteriological outfit, and a creditable library of biology and fish-culture has been installed. Two steam launches and the schooner *Grampus* have been attached to the Station, several fin-mesh seines, trawls and tow-nets have been purchased, and a large fish-trap has been placed at a favorable locality.

From the day of the opening of the laboratory, April 1st, several tables have been continuously occupied, and, at the present time, the scientific force numbers twenty-four. Several have expressed the desire of extending their work during the

autumn and winter months, and it is proposed to keep the laboratory open throughout the year.

The Commission does not attempt to instruct or to dictate as to what lines of research are to be pursued, how the work shall be carried on, or where the results shall be published. It is convinced that all lines of biological research are indirectly, if not also directly, helpful to its more immediately practical work, and it happens that fully one-half of the investigators are now busy with problems bearing directly upon the anatomy, embryology, physiology and pathology of fish. The large corps of collaborators has made it possible to secure definite data respecting the breeding habits of many marine forms. The floating-fauna has been systematically examined; valuable information has been gained respecting the larval life of the star-fish, the developmental stages of the clam, the rate of growth of the scallops, the causes of mortality of lobster fry, and the pathogenic bacteria infesting fish.

With the cooperation of the Marine Biological Laboratory, it is proposed to make a series of synchronous observations on the temperature and floating fauna of Vineyard Sound. The combined vessels of the two laboratories provide a sufficiently large fleet to make these observations of special interest. It is also proposed to resume again the deep-sea work begun by the Commission many years ago, though the temporary use of the *Fish Hawk* by the United States navy will prevent the work from being undertaken the present season.

H. C. BUMPUS.

*ZOOLOGICAL NOTES.*

PUBLICATIONS OF THE AMERICAN MUSEUM OF NATURAL HISTORY.

THE Report of the American Museum of Natural History, New York, for 1897, re-

cently issued, has for its frontispiece a view of the south front as it will appear when the work on the east and west wings, now in progress, is completed. This front will have a length of 700 feet and, great as it will be, the area covered is only about a third of that planned for the finished structure. This will afford room for growth for many years to come, without any crowding of the collections, and it is small wonder that the American Museum, with its spacious exhibition halls, laboratories and offices, is at once the admiration and envy of other institutions.

Other illustrations in this report are views of collecting parties at work in Nebraska, and some of the mounted specimens in the paleontological hall. Although the Department of Vertebrate Paleontology has been organized but seven years, this hall already contains what is probably the most impressive exhibit of fossil vertebrates in the world, and while the beauty of Mr. Hermann's preparations can be readily appreciated by the average visitor the phylogenetic arrangement of the collections is of great interest to the student.

The American Museum has also issued an illustrated catalogue of casts, models, photographs and restorations of fossil vertebrates which are to be had in exchange or, in certain cases, are for sale. The statuettes of Mr. Knight are extremely good and show the great advance that has been made in our knowledge of extinct forms since Waterhouse Hawkins perpetrated his flights of fancy for the Crystal Palace. Of course, it may be said that he had little or no data on which to base his 'restorations,' but it would seem better, under the circumstances, not to have attempted them at all, on the ground that it is better 'not to know so much than know so many things that ain't so.' The most striking and vigorous of Mr. Knight's restorations is probably the one most open to criticism, but

there are many who will hesitate to accept without reserve the form and attitudes ascribed to *Megalosaurus (Laelaps) aquilunguis*.

F. A. L.

CURRENT NOTES ON METEOROLOGY  
THE CLIMATE OF THE PHILIPPINES.

THE climatic conditions of the Philippine Islands are just now attracting considerable attention, and brief notes, usually very general in character, concerning these conditions are finding their way into print. The 'Philippine Number' of the *National Geographic Magazine* (June) contains an article by F. F. Hilder (also published, substantially unchanged, in the *Forum* for July), two pages and a-half of which are devoted to the climate of the Philippine group of islands. The seasons at Manila are described by the Spaniards as

"Seis meses de lodo,  
Seis meses de polvo,  
Seis meses de todo ;"

six months of mud, six months of dust and six months of everything. Other brief notes are found in *Scribner's Magazine* for June, in an article on 'Manila and the Philippines,' by Isaac M. Elliott, formerly U. S. Consul at Manila, and in the *American Monthly Review of Reviews* for June, in an article by J. T. Mannix, entitled 'Notes on the Philippines.'

There is much confusion in the public mind just now as to the question of the health of North American troops during a temporary sojourn in the Philippines, and also as to the larger question of possible acclimatization of our people in those islands, in case of permanent occupation. No definite answers can be given to these two questions, but in their consideration three things may well be borne in mind. *First*: By means of a strict observance of hygienic principles, the death rate among foreigners in a tropical country can be very



much reduced. This has been nowhere better shown than in the case of the British troops in India and of the French troops in Cochin-China. *Second*: The great majority of the best authorities are agreed that complete acclimatization of Europeans (and hence, we may add, of North Americans) in the tropics is impossible. By exercising the greatest care, they may *live* in tropical countries, but, as has been well said by a recent writer, to tolerate a climate is one thing; to be independent of it is quite another. *Third*: The Anglo-Saxons are universally acknowledged to be the least fitted, the Mediterranean nations the best fitted, to colonize in the tropics.

#### MONTHLY WEATHER REVIEW FOR APRIL.

THE April number of the *Monthly Weather Review* contains several articles of general interest. In an account of 'A Visit to the Highest Meteorological Station in the World,' R. DeC. Ward describes his experiences on two trips to the summit of El Misti (19,200 ft.), near Arequipa, Peru, where the Harvard College Observatory maintains a meteorological station which is at present, and is likely to be for some time to come, the highest in the world. In 'Meteorological Work in Alaska,' A. J. Henry, Chief of the Division of Records and Meteorological Data of the Weather Bureau, gives an account of the recent observations that have been made in that Territory. Two papers by A. Lawrence Rotch concern 'The International Aëronautical Conference,' recently held at Strassburg, and 'The Eighth General Meeting of the German Meteorological Society.' Professor Cleveland Abbe, the editor of the *Review*, contributes articles on 'The Rainfall and Outflow of the Great Lakes,' 'Lightning on the Kite Wire,' and other matters.

SONNBLICK VEREIN.

THE sixth *Jahresbericht* of the Sonnblick

Verein, a society which has for its object the maintenance of the now famous meteorological observatory on the Sonnblick, contains an appreciative account, by Dr. von Obermayer, of Dr. Jacob Breitenlohner, who had much to do in the original planning of the observatory on the Sonnblick; an account of the medal given to Dr. Hann on his retirement from active service in Vienna; the meteorological summaries for 1897 (for Sonnblick and Rauris), and a report of the annual meeting of the Verein. Several changes and improvements have been made during the year, the most important of which is the establishment of a new base station, connected by telephone with the summit and with the Rauris station. At this new station observations were begun on January 1st of this year.

#### NOTES.

DR. HANN contributes another noteworthy publication to the valuable series of meteorological discussions which have appeared in the *Sitzungsberichte* of the Vienna Akademie der Wissenschaften. The present report is entitled *Weitere Beiträge zu den Grundlagen für eine Theorie der täglichen Oscillation des Barometers*, a subject to which the author has already given much study. The data used in this investigation come from many different sources, and from widely scattered regions, and are analyzed with Dr. Hann's customary accuracy and care.

On the *Pilot Chart of the North Pacific Ocean* for July there is reprinted, from the Report of the Director of the Hongkong Observatory for 1897, a classification of typhoons, based on the seasons of the year and the regions in which these disturbances occur. This classification is of special interest at the present moment.

R. DE C. WARD.

HARVARD UNIVERSITY.



## CURRENT NOTES ON ANTHROPOLOGY.

## LATER CRIMINOLOGY.

A FEW years ago most of us had considerable faith in Lombroso's 'criminal type.' We looked at ear-lobes and finger-nails, and thought we detected in them the 'stigmata of degeneration.'

This illusion was lost when it was found that in fact the criminal was about as well formed as the jury or the Judge. The 'criminal type' fell into oblivion.

But the 'criminal mind' remained. The psychology of evil doers must have something in it radically different from that of 'respectable people.' We forgot the force of the Rev. John Newton's saying, when he saw a thief led to the gallows: "There goes John Newton, but for the grace of God."

Now, however, such authorities as Näcke and Baer and Dallemagne have pronounced the whole edifice of 'criminal psychology' a phantom and a delusion. Criminals are just like other people of their sex, age and condition in life. They are tempted, fall and are caught (especially the last), and that is the only difference.

Such is the summary of the case in the *Centralblatt für Anthropologie*, 1898, Heft II.

## THE DELUSION OF 'ATAVISM.'

'ATAVISM,' or 'reversion,' in the dialect of the evolutionist means a recurrence to a more or less remote ancestral type, and in theory it is brought about through the 'immortality,' as it has been boldly called (by Lapouge), of the germplasm (*Keimplasma*).

Some years ago (1894) I urged in a paper before the American Association that most so-called reversions in the human skeleton have other and better explanations. Now comes a Dutch physician, Dr. Kohlbrugge, and maintains that all alleged atavistic anomalies are merely neutral variations due to ordinary causes (mal-nutrition,

use, disuse, etc.); and, as they vary from a mean in one direction or the other, they assume a deceptive appearance of regressive or progressive variation, the former reaching to what has fallaciously been considered reversion and atavism. For this he brings considerable evidence. This book is published at Utrecht by Scriverius, and is well reviewed in the *Centralblatt für Anthropologie*, 1898, Heft. 2.

## ORIGIN OF THE CLIFF DWELLINGS.

IN the *Bulletin* of the American Geographical Society, No. 2, 1898, Mr. Cosmos Mindeleff has a thoughtful article on the origin of the cliff dwellings.

He shows with satisfactory clearness that they are 'the direct result of the peculiar geographic environment.' Like the Pueblos, they are completely adapted to the country in which they are found. Only the 'kivas' or estufas may be regarded as a transplanted feature. These are 'undoubtedly a survival from the time when the people lived in circular lodges, like the Navahoes of to-day.' Many of the sacred ceremonies could be properly performed only in a circular chamber. The cliff ruins exhibit a long sequence of time, but not a development.

He concludes with the general maxim: "The study of an Indian art is the study of the conditions under which it was developed."

In this connection I should mention a carefully prepared article in the *American Anthropologist* for May, by Walter Hough, on 'Environmental Interrelations in Arizona.'

D. G. BRINTON.

UNIVERSITY OF PENNSYLVANIA.

## SCIENTIFIC NOTES AND NEWS.

## EXTENSION OF THE WEATHER SERVICE.

THE Weather Bureau has decided to make an important extension of its service by establishing ten or more stations on the Caribbean

Sea. It is expected that a central station will be established in Jamaica or Cuba which will be under the direction of Professor Mark Merrill, now at Washington, and W. B. Stockton, now at Cleveland. Stations will probably be situated on Barran Quilla, Columbia, St. Kitts (southeast of St. Thomas), Trinidad, Curaçao, Martinique, San Domingo and the Barbadoes, and on the north coast of South America. Among those who it is expected will be assigned to these stations are Messrs. Franklin G. Tingley, of Indiana; John W. Towers, of New York; Thomas Crawford, of Jacksonville, Fla.; Frank A. Davis, of Philadelphia; Louis Dorman, of Pittsburgh, and John M. Ryker, of Galveston.

It is planned to make weather charts for the region extending from Central America to the Caribbean islands and from the southern coast of North America to the northern coast of South America. Reports, forecasts and warnings will be sent out to the central station and thence to Washington, whence they will be distributed wherever needed. In cases where indications of an approaching tornado occur the observers will be empowered to send out telegraphic warnings at intervals of two hours, so that a place within the path of the tornado will have ample time to make preparations before the actual arrival of the storm. It is hoped by this means to aid and safeguard the important commercial undertakings which are being rapidly built up in the region.

#### THE SPECTRUM OF METARGON.

PROFESSOR ARTHUR SCHUSTER writes to *Nature* that in the account given by Professor Ramsay of his researches on the 'Companions of Argon' he has omitted to draw attention to a very curious similarity between the spectrum of his new gas 'metargon' and the ordinary spectrum of carbon, with which every student of spectrum analysis is familiar.

The following comparison of wave-lengths will make the similarity apparent:

		Ramsay's metargon.	Carbon (Angström and Thalén.)
Citron band	1	... 5632.5	... 5633.0
	2	... 5583.0	... 5583.0
	3	... 5537.0	... 5538.0
Green band	1	... 5163.0	... 5164.0
	2	... 5126.5	... 5128.0

Blue band	1	... 4733.5	... 4736.0
	2	... 4711.5	... 4714.5
Indigo band	...	4314.5	... 4311.0

There are three of Ramsay's bands not included in this list, but these are nearly coincident with known bands in the cyanogen spectrum.

It seems hardly credible that Professor Ramsay has not guarded against the possibility that all these bands may be due to carbon, and not to a new gas; but some explanation seems required, for, though the coincidences in the two sets of bands is not complete, there is no case known in which two different elements have spectra so nearly alike as those of carbon and metargon seem to be.

#### THE BRITISH GOVERNMENT AND ANTARCTIC EXPLORATION.

WE have on several occasions called attention to the efforts made by the Royal Geographical Society and the Royal Society to obtain the cooperation of the British government in sending an expedition for the exploration of the Antarctic Continent and Ocean. We regret to learn that the government has declined to undertake to make itself responsible for the expedition. The official letter addressed by Sir Clements Markham to Lord Salisbury on October 26, 1897, has just been made public. In its course Sir Clements says:

Last year, under instructions from the Council of the Royal Geographical Society, I brought the matter to the notice of the First Lord of the Admiralty, as it was felt that such an expedition should be a naval expedition, in accordance with all precedents. A reply was received, dated the sixth of April last, to the effect that the Lords Commissioners of the Admiralty regret to be unable to take any part in the organizing of such an expedition, but that at the same time they regard the enterprise as one which is important in the interests of science. Although the present exigencies of the naval service prevent their lordships from lending officers, they will watch the result with great interest, and will be prepared to aid in other ways.

Great regret will be felt throughout the country that the navy should be deprived of the conduct of enterprises of this character, which have always belonged to it from the days of Anson, and from the results of which not only the naval service and the

country, but the whole civilized world, have derived benefit.

But this unfortunate inability, caused, in the opinion of their lordships, by the exigencies of the present time, does not preclude the despatch of an Antarctic expedition under the sanction and authority of her Majesty's government, led by competent seamen and scientific persons who could perform this difficult service satisfactorily.

Grants from the Treasury for such purposes have been so frequent that they may be considered as part of the public policy of the country. To mention those only which were directly connected with this Society, there were the grants in aid for the expeditions of Schomburgk, of Burton, of Speke, of Livingstone, of Cameron, and, more recently, the grant of £1,000 in connection with Mr. Leigh Smith's Arctic expedition.

\* \* \* An Antarctic expedition would be most efficiently conducted if the funds were supplied and the details were organized by the government, perhaps through the agency of a specially appointed committee. At the present time, even apart from naval officers, there are scientific seamen and travelers of experience known to myself and my Council who would form a capable staff. My Council trusts that such an arrangement will secure your lordship's approval. An alternative course would be that, with the aid of grants from the Treasury and the governments of the Australasian colonies, the Council of this Society should undertake the responsibility of equipping and despatching the expedition.

The final reply from the Foreign Office, dated June 9, 1898, says:

That after carefully consulting the authorities at the Treasury and the Admiralty, Lord Salisbury is unable, under existing circumstances, to hold out any hope of the government embarking upon an undertaking of this magnitude. Lord Salisbury has made inquiry through the Secretary of State for the Colonies as to the attitude of the Australasian colonies towards the proposal for further Antarctic exploration; and he is informed that at the recent Conference of Premiers held at Melbourne in March last it was resolved that those colonies should take no joint action in the matter; and the cooperation anticipated by the Society from that quarter will not apparently be afforded by the colonial governments.

The Royal Geographical Society will now endeavor, without the aid of the British government, to obtain the funds for an expedition to be sent out under the Society's auspices. They have authorized the President to take steps to obtain subscriptions to the amount of not less than £50,000; the Society itself contributes £5,000.

#### PROFESSOR KOCH ON THE PLAGUE.

PROFESSOR KOCH was the guest of the German Society for Public Hygiene on July 7th, and delivered an address on the subject of the plague, in which he dealt especially with his discovery of a plague center in the *Hinterland* of German East Africa, whither the disease had been introduced from Uganda. According to the report in the *London Times* he gave a survey of the recent epidemics in Mesopotamia, Persia, China and India, which pointed out that the view entertained ten years ago that the plague was no longer a danger to the nation was shown to be untenable.

A rich harvest of results had been reaped from the study of the plague with the aid of modern means of investigation. The disease had been demonstrated to be caused by bacteria, and useful lessons had been drawn regarding the best methods of combating its ravages. There were excellent prospects of progress in the direction of creating artificial immunity. The part played by rats in the dissemination of the plague has been elucidated, so that it might be said that the plague was really a rat disease. One question, however, to which a satisfactory answer had not yet been given related to the ultimate origin of the disease. The old explanation that it was found wherever dirt and social misery prevailed was inadequate. There must be places where it was endemic and whence it was transplanted into districts that had hitherto been free from infection. Former outbreaks could be traced back to Mesopotamia, where the plague had never entirely disappeared. But whence came the Chinese plague? It could be proved that its endemic center was in Hunan. Tibet was a second center, and the latest outbreaks in China, as in India, had their origin there. The third center was on the west coast of Arabia, in the vicinity of Mecca. This center had a special importance in view of the numerous pilgrims who visited it, but it was, after all, doubtful whether the plague was endemic in the neighborhood of Mecca. The constant cases which occurred there might only be survivals of the disease as introduced by large masses of people from abroad. Nothing had hitherto been known of any other plague center besides these enumerated, but Professor Koch



now claimed to have discovered a fourth center in Equatorial Africa. It had been found that a devastating disease prevailed at Kissiba, in the extreme northwest corner of German East Africa, close to the Victoria Nyanza. Suspecting that it was the plague, Professor Koch proceeded from India to East Africa, in order to make investigations. With the help of Dr. Zupitza, who made a special expedition to Kissiba, he had been enabled to identify the disease as the bubonic plague. In the case of five persons who had died from the disease anatomical preparations were obtained and the blood and lymphatic glands of plague-stricken patients were bacteriologically examined. All the ordinary features of the bubonic plague were present. Nine out of ten of those who were infected died. The disease was communicated to rats and to monkeys. It was found that an outbreak of the plague among rats frequently preceded a human epidemic, and, in fact, the rat plague might always be regarded as a warning.

#### GENERAL.

WE learn with much regret that on the ground of ill health Sir William Flower has resigned the directorship of the Natural History Museum, London.

THE Berlin Geographical Society has elected as honorary members Professor W. M. Davis, Mr. G. K. Gilbert, M. A. de Lapparent and Professor H. Mohn.

THE University of Michigan has conferred the degree of LL.D. on Dr. A. Jacobi, clinical professor of the diseases of children in Columbia University.

HAMILTON COLLEGE has conferred the degree of Sc.D. on Mr. William R. Brooks, Director of the Smith Observatory, at Geneva, N. Y.

DUBLIN UNIVERSITY has conferred *honoris causa* the degree of Sc.D. on Mr. Robert Henry Scott, Superintendent of the Meteorological Department in London.

WE regret to record the death of Professor Anton Kerner, Ritter von Marilaun, the eminent botanist, professor in the University of Vienna.

MR. ALEXANDER WHYTE has been appointed,

by the British government, scientific adviser in Uganda, where he will establish a botanic garden and experiment station.

MR. E. B. DUNN, Local Forecaster of the Weather Bureau, in New York, has resigned the position, which he has held for the past fifteen years; Mr. Eben H. Emery has been appointed his successor. Mr. Emery is a graduate of Bates College, and has been connected with the weather service for fourteen years. During the past four years he has been First Assistant in New York, and his promotion is in accordance with the principles of civil service reform.

DR. OSWALD LOHSE, of the Astrophysical Observatory in Potsdam, has been promoted to the rank of a professor.

PROFESSOR D. G. RITCHIE, of St. Andrews, has been elected President of the Aristotelean Society, London.

THE Epidemiological Society of London has made the first award of its Jenner Medal to Mr. William Henry Power, F.R.S., Senior Assistant Medical Officer of the Local Government Board.

THE Physico-agricultural Society, which in 1798 removed from Mohrungen to Königsberg, offers in commemoration of the centennial celebration a prize, the cost of which is defrayed by Dr. Walter Simon. The subject proposed is a research on 'Animal or Plant Electricity' and the value of the prize is 4000 Marks. The competition closes on December 31, 1900, and is open to citizens of any country. The essays may be written in German, French, English or Italian and may be published at any time after September 30th, of the present year.

AT a meeting of members of the Royal Institution on July 6th special thanks were returned for the following donations to the fund for the promotion of experimental research at low temperatures: Mrs. G. J. Romanes, £5; Sir Frederick Bramwell, £100; Professor Dewar, £100; Dr. Ludwig Mond, £200; Mr. Charles Hawksley, £100; Sir David Salomons, £21; and Dr. Rudolph Messel, £100.

SIR ROBERT RAWLINSON, formerly Chief Engineer Inspector of the London Local Government Board, who died on May 25th, aged 88 years, bequeathed £1,000 to the London Insti-



tution of Civil Engineers. He also left a large sum, apparently about £35,000, to St. Thomas Hospital, London.

THE International Congress of Zoology, which opens at Cambridge on August 22d, will be divided into four sections: (a) General Zoology; (b) Vertebrata; (c) Invertebrata (except the Arthropoda); (d) Arthropoda. There will be two general discussions, one on 'The Origin of the Mammalia,' opened by Professor Osborn and Professor Seelye, of London, and one on 'The Position of Sponges in the Animal Kingdom,' opened by Professor Delage, of Paris, and Mr. Minchin, of Oxford.

WE are requested to state that it has been agreed by the Executive Committee that ladies attending the Fourth International Congress of Zoology at Cambridge in the company of a member may become associates on the payment of 10s. This payment shall entitle them to attend the general and sectional meetings, and the receptions held during the meeting of the Congress at Cambridge. An associate's ticket shall not be transferable and shall not entitle the holder to receive a copy of the final report.

At the Washington meeting of the National Educational Association the Natural Science Department received reports from the several committees of twelve charged with the preparation of a course in science for the secondary schools. The subjects considered are physics, chemistry, physical geography, zoology and botany. The committees represent the Natural Science Department of the National Educational Association, the American Association for the Advancement of Science, and the several Associations of Colleges and Preparatory Schools. The chairmen for the five subjects were appointed as a committee to correlate the reports and to present, as soon as practicable, a matured scheme of science instruction for the schools. The chairmen are: for physics, Professor E. H. Hall, of Harvard; for chemistry, Professor Alexander Smith, University of Chicago; for physical geography, Professor Albert Perry Brigham, Colgate University; for zoology, Professor H. B. Ward, University of Nebraska; for botany, Professor J. M. Coulter, University of Chicago.

THE Russian Association of Naturalists and Physicians will hold its tenth meeting at Kief during the last week in August.

THE Ninth Congress of French Alienists and Neurologists will open at Angiers on August 1st, under the presidency of Dr. Mottet. The Fourth French Congress for the Study of Tuberculosis from the 27th of July to the 1st of August, under the presidency of Professor Nocard.

THE Sixteenth Congress of the Sanitary Institute will be held at Birmingham, England, from September 27th to October 1st, under the presidency of Sir Joseph Fayrer. There will be three sections: (1) sanitary science and preventive medicine; (2) engineering and architecture, and (3) physics, chemistry and biology. There will also be special conferences and an exposition. Dr. Christopher Childs will lecture before the Congress and Dr. A. Hill will give a popular lecture.

A PROPOSAL has been made by the Bombay Medical and Physical Society to hold a congress at Bombay at the beginning of the winter to make a thorough study of the plague.

THE Mining Congress, in its recent session in Salt Lake City, has adopted a memorial to Congress asking for the creation of a department of mines and mining. The next meeting of the Congress will be in Milwaukee, beginning September 7, 1899.

MAYOR VAN WYCK, of New York, has made a statement before the Board of Estimates stating that he is not opposed to the Public Library, the Botanical and Zoological Gardens and the Museums, but he thinks that they should be owned and controlled by the city. He stated that he would favor appropriating \$15,000,000, if necessary, for a public library. A few weeks ago, however, the Mayor said that the \$150,000 needed to prepare the site for the new public library could not be given because the city had exceeded its debt limits. The construction of the library was authorized before the present administration came into office, and it is to be hoped that the money already appropriated cannot long be withheld.

THE Committee of the House of Commons on the Museums of the Science and Art Department has recommended, as we have already

mentioned, the removal of the Museum of Practical Geology from Jermyn street to South Kensington. Many protests have been made against this plan and a memorial signed by about 500 members of the Geological Society has been presented to the government urging serious objections to it.

It is stated in *Nature* that the fourteenth annual general meeting of the Marine Biological Association was held on June 28th; Professor E. Ray Lankester, F.R.S., President, being in the chair. The Report of the Council dealt largely with the work done at the Plymouth Laboratory during the year. Reference was made to Mr. Garstang's investigations of the habits and migration of the mackerel; to Mr. Holt's researches on the reproduction and development of fishes living in the neighborhood of Plymouth, and their distribution at different ages; as well as to the experiments with floating bottles for determining the surface drift in the English Channel, and to the systematic investigation of the dredging and trawling grounds between the Eddystone and Start Point. Twenty-two naturalists and eight students were reported as having worked at the Laboratory since the last annual meeting, in addition to the members of the regular staff. The following were elected members of Council for the year: President, Professor E. Ray Lankester; Hon. Treasurer, J. A. Travers; Secretary, E. J. Allen. Council: F. E. Beddard, Professor Jeffrey Bell, G. C. Bourne, Sir John Evans, G. H. Fowler, S. F. Harmer, Professor Herdman, Professor Hickson, J. J. Lister, Sir John Murray, P. L. Selater, D. A. Scott, Professor C. Stewart, Professor W. F. R. Weldon.

It will be remembered that sometime since Baroness Hirsch presented 2,000,000 fr. to the Pasteur Institute, Paris. It has been decided to use this sum for the construction and maintenance of a biological institute, which shall be placed opposite the Pasteur Institute, on the rue Dutot. M. Duclaux will be Director of the new Institute, while M. Gabriel Bertrand will have charge of the laboratories of physiological chemistry.

THE Academy of Medicine of Paris has for forty years had no home, says the New York

*Medical Record*, its meetings being held in the old chapel of the Charité Hospital. It owns ground near Luxembourg, which the government has appropriated for a school of chemistry. In compensation for this lot the French legislature has appropriated a sum sufficient for the purchase of a site for a building on the rue Bonaparte. On this ground the Academy will soon erect a suitable building, where its meetings can be held and which then will be used for storing transactions, for the library, or for the various departments which are under the care of the Academy—for instance, the vaccination department, the board in charge of prophylaxis and treatment of epidemic diseases, the board to which is intrusted the care of the various mineral springs, the sanitary and statistical departments, and the office for dealing with awards granted for sundry scientific researches.

WE learn from the London *Times* that the Lord Mayor of Liverpool opened on July 4th another institution in connection with University College in that city. This is Ashton-hall, a museum and school of hygiene. The building was presented by the late Mr. George Holt, and remodeled with funds provided by Mrs. and Miss Holt and the Technical Instruction Committee. It is a large building, with well-lighted museum, laboratories and lecture room, the latter fitted with an electric air lamp. The museum rooms are well fitted, and are already stocked with numerous useful exhibits. The opening ceremony took place in the Arts Theatre of University College, under the presidency of Councillor Willink, Chairman of the Sanitary Science Instruction Committee. Dr. E. W. Hope said it was the late Mr. Holt's wish that the building should be devoted to some branch of medicine having for its object the promotion of public health, and the medical faculty of the College thought they would be giving effect to his wishes by using the building for a museum and school of instruction in public health matters and for research in subjects connected therewith. The building was well equipped for these purposes, including investigation of advanced sanitary problems, such as the purification of water and sewage, the action of disinfectants, and so forth. The

Lord Mayor said that, though it had only been in use a few months in the training of students who wished to become sanitary inspectors, 14 young townsmen had passed the examination and in due course would get certificates and be qualified to act as sanitary inspectors.

THE Select Committee on the Museums of the Science and Art Department, met again on July 5th, as we learn from the *London Times*, and made further progress with the consideration of their report. Certain paragraphs of a recommendatory character were postponed; but the portion of the Chairman's draft dealing with the origin and development of the several museums which remained to be discussed was finally disposed of, and when the Committee reassemble they will proceed at once to formulate their conclusions. Although the question of recommendations has yet to be dealt with, Sir Francis Powell's draft report has already undergone considerable alteration, not the least important of the amendments accepted by the Committee being one relating to the Bethnal-green Museum (submitted by Sir Mancherjee Bhowanagjee) declaring that, inasmuch as no arrangement has been made to provide technical instruction in connection with this institution, the object of its inception remains unrealized. The official records show that the Bethnal-green Museum was established to provide for the working population of the East End adequate means of instruction, and that promises were repeatedly given that a school of science and art with a library attached should be started. The complaint from the locality is that no attempt has been made to redeem these promises.

A LETTER has been received by the London School Board from the London County Council stating that the Parks and Open Spaces Committee had considered the Board's letter of May 24th last, which enclosed an extract from a report from the British Embassy at Berlin, as to the arrangements in force in that city for facilitating the study of botany, and which asked the Council whether a somewhat similar arrangement could not be made in London. The County Council informed the Board that they were taking steps in this direction by forming

a series of beds in Battersea, Ravenscourt and Victoria Parks, with specimens of plants in their natural orders, and added that the Parks Committee thought that it would be desirable to see the result of this experiment before proceeding any further for the present.

'A REVISION of the Genus *Capsicum*, with especial reference to garden varieties,' is the title of an article by Mr. H. C. Irish in the last report of the Missouri Botanical Garden. From it we learn that some years since, Dr. Sturtevant, then of the New York Agricultural Experiment Station, planned a systematic study of the *Capsicum*, from an agricultural rather than a strictly botanical standpoint, and, his material, notes and library having been subsequently presented to the Missouri Botanical Garden, for some years past all procurable varieties of this polymorphic genus have been grown in St. Louis and made the subject of current study. In the present paper Mr. Irish, the Horticultural Assistant at the Garden, brings together the result of this study, prefacing the systematic portion by a general account of Capsicums and their uses. A minutely divided analytical key to the garden peppers is provided, and in the synopsis these are all arranged under two species, *C. annuum* and *C. frutescens*, the several botanical and many horticultural varieties of which are described in considerable detail. An unusual feature, for a horticultural paper, is the very large citation of references, especially to early literature, many of which were accumulated by Dr. Sturtevant, and in the verification of which the magnificent pre-Linnean library which he brought together has been invaluable. All of the principal varieties are represented in simple but effective outline drawing. Mr. Charles Henry Thompson, who last year published a study of the Wolfiellas of the United States, contributes to the *Report* a careful revision of all of the Lemnaceæ occurring in the United States, in which analytical keys and good illustrations are provided for the ready determination of the species.

A CIRCULAR has been issued by The Bureau of Mines, Toronto, stating that the first discovery of Corundum in Ontario was made late in the



year 1896, and exploration work carried on under direction of the government in 1897 shows that the Corundum-bearing lands have an aggregate area of about 50,000 acres, lying in the townships of Carlow, Bangor, Raglan, Radcliffe, Brudenel, Lyndoch and Sebastopol, in the counties of Hastings and Renfrew. The mineral rights over nearly the whole of this tract are held by the crown, and they have been withdrawn from sale and lease pending a report on the occurrence of the mineral and the methods of treating it, undertaken by the professors of the Kingston School of Mining. This report and a map of the Corundum region has been published, and copies of it may be had on application to the Bureau of Mines, Toronto. The attention of prospectors, miners and capitalists is invited to the district, and, with a view to its development and the establishment of industries in the Province for treating and utilizing the Corundum ore, proposals will be received until the first day of September next. Preference in the selection of mineral lands will be given to parties who will undertake to conduct mining and treating operations on the largest and completest scale, and who can furnish satisfactory assurances that they possess the requisite capital for the proposed operations, including separation of the ore from its gangue, milling for abrasive uses, manufacture of abrasive goods, and the production of aluminium if the ore is suitable therefor. Water-power of large capacity is available in the locality for electrical and other works; and during the summer season the lands are easily accessible by steamboat from Barry's Bay station, on the line of the Ottawa, Arnprior and Parry Sound Railway. The lands will be disposed of under the leasehold system, renewable for fixed periods indefinitely at a low rental, subject to the performance of working conditions as provided in the regulations governing the same.

WE learn from *Natural Science* that the Trustees of the British Museum have recently purchased the large collection of marine animals formed by Canon A. M. Norman, and containing type-specimens of many species which he has established. Part of the collection is already in the Museum; the rest will go there eventually. The Edinburgh Museum of

Science and Art has recently acquired the valuable collection of fossils from the Upper Silurian rocks of the Pentland Hills, made by the late David Hardie, of Bavelaw. It is especially rich in specimens from the Eurypterid beds of Gutterford Burn, near Carllops, Peeblesshire; there are also specimens, chiefly sponges, from North Esk.

IN view of the importance of photography for scientific expeditions Mr. W. J. Stillman writes to the London *Times* on experiments made by him, demonstrating the advantage, of using 'cut-films' of celluloid as a substitute for glass. These films are shavings, about the fourth of a millimeter in thickness, from a solid block of celluloid, practically not breakable, and lying flat in the holder like glass. Mr. Stillman writes as follows: "Considering the extreme portability and infrangibility of these films and their inestimable superiority in these respects over glass, and in other respects over paper, I think that these experiments have a high value for scientific voyagers, to whom photographic illustration is so important and the difficulties of photographic operation *en voyage* are so great. *A priori*, as the celluloid is produced under the action of strong acids, and has a certain tendency to liberate the acids with time, their action tending to cause insensibility in the haloid which holds the photographic image, I believed that in so long a time as is covered by my experiment they would have become quite insensible, but I did not see that in this respect there was much falling off. A little there probably is, for in the case of films of the highest sensibility I have found that impressibility for all practical purposes had disappeared after a year, those of lower sensibility losing less in proportion; but this is of absolutely no moment, exposure in the camera for a second more or less being a matter of no importance. The fact that a traveller may with this portable and unbreakable material spend years in the most difficult explorations with photographic record possible at all stages, and develop it on his return home, ought to be of scientific import."

TECHNICAL inventions naturally lead to the invention of new names, but rarely in such variety as the following synonyms, for all of which we cannot, however, vouch, collected by



a daily paper : Vitascope, kinoscope, phantoscope, criterioscope, cinematograph, biograph, kinematograph, wonderscope, animatoscope, vitagraph, panoramograph, cosmoscope, anarithmoscope, katopticum, magniscope, zeoptrotrope, phantasmagoria, projectoscope, variscope, cinograph, cinomograph, hypnoscope, centograph, x-ograph, electroscope, cinagraphoscope, eraboscope, vitaliscope, cinematoscope, mutoscope, cinoscope, animaloscope, theatograph, chronophotographoscope, motograph, kinetograph, rayoscope, motorscope, kinetinephone, throtrotrope, phenakistoscope, venetrope, virtoscope, zinematograph, vitopticon, stinetiscope, vivrescope, diaramiscope, lobsteroscope, cornomograph, kineoptroscope.

Graduate students.....	143
Collegiate students.....	993
Law students.....	102
Special professional students.....	30
Agricultural and mechanical school.....	36
School of art and music.....	325
Preparatory school.....	190
Summer school.....	262

Deducting duplicated names there were 1915 in all, of which 1,043 were men and 872 women. The instructional staff and assistants numbered 184.

Two hundred and fifty students were enrolled in the summer session of the University of Nebraska, June 6th to July 16th. Hitherto this has been a semi-independent summer school, but this year the experiment was made of offering condensed courses of regular University work. By more frequent meetings of classes and more hours per week in the laboratories, as much was accomplished in many subjects in six weeks as in a full semester under ordinary conditions. The success of the summer session just closed encourages the University authorities to continue the experiment next year. Fully sixty-five per cent. of the students in this session were teachers in the schools of the State.

UNIVERSITY AND EDUCATIONAL NEWS.

DR. E. BENJAMIN ANDREWS, President of Brown University, has been elected Superintendent of the Chicago Schools by the Board of Education. Thirteen votes were cast for Dr. Andrews and six for Albert G. Lane, the present Superintendent. Dr. Andrews will accept, and will assume the duties immediately. Professor Benjamin Ide Wheeler, who holds the chair of Greek at Cornell University and is an alumnus of Brown University, is prominently mentioned in connection with the vacant presidency.

It has been ordered by the Russian Minister of Public Instruction that the number of Jewish students in any faculty of the University of Moscow shall not exceed three per cent. of the total number of students in that faculty.

PROFESSOR JOHN M. COULTER, head of the department of botany in the University of Chicago, is Principal of the Winona Assembly and Summer School, which is holding a session from July 4th to August 28th. The buildings and grounds have been fitted up at a cost of about \$300,000.

THE Egyptian Ministry of Public Instruction advertises for a senior and a junior professor of agriculture for the School of Agriculture, Gheezeh. The salaries are about \$2,500 and \$1,500 per annum. Applications may be made before August 12th to the Principal of the School, W. C. Mackenize, D.Sc., 6 Hartington Gardens, Edinburgh.

THE sixth volume of the *Annual Register* of the University of Chicago is a book of 480 pages. The summary of attendance shows a total enrollment for the year of 2,307 students, 1,428 men and 879 women. By quarters the figures are :

IN the absence of Mr. W. H. R. Rivers, who is accompanying Professor Haddon on his expedition to the Torres Straits, courses in experimental psychology in University College, London, will be given by Mr. E. T. Dickson.

Summer, '97.....	1273
Autumn, '97.....	1170
Winter, '98.....	1169
Spring, '98.....	1094

DR. WILLY KUNKELTHAL, associate professor of zoology at Jena, has been called to a full professorship in Breslau; Dr. F. J. Becker, professor of mineralogy in the German University at Prague, has been called to Vienna.

THE enrollment of students in the University of Nebraska for the year 1897-98 was as follows :

DR. GEORG KARSTEN, docent in botany in Kiel, Dr. Richard Abegg, docent in physical chemistry at Göttingen, and Dr. Böhming, docent in zoology at Gratz, have been promoted to associate professorships. Dr. Reitzenstein has qualified as docent in chemistry at Würzburg and Dr. Simon as docent in physics in Göttingen.

#### DISCUSSION AND CORRESPONDENCE.

##### SUBSTITUTIONAL NERVOUS CONNECTION.

IN a series of recent papers the writer has endeavored to show that the idea now apparently dominant that, with the single exception of the olfactory, the peripheral nervous connections are indirect rather than direct is an unwarrantable assumption. It has been found possible to demonstrate in the skin termini of nerves which are, so far as can be seen, unimpeachable instances of connection by continuity. These are then of the same nature as the connections of the olfactory cells with the fibres of the olfactory nerve. On the other hand, it appears that some of the most careful observers have detected similiar rod-cells with special nervous functions which are only in indirect communication with the nerve which conveys the stimulus. If it could be shown that the sensory cells are uniformly without nervous processes it might be assumed that they constitute by themselves a special class of nervous organs which normally do not acquire the neurite, but the admitted existence of such a process of the olfactory cells and the fact that these cells are otherwise so similar to the other instances of nervous endings, in which it seems to be proved that this sort of direct connection is absent, prevents the possibility of establishing such an independent class of structures. Still more, if our own observations are taken into account, it seems necessary to offer some other suggestion to account for the discrepancy in this particular. Take, for illustration, the case of the organs of taste, which, in spite of their evident resemblance to the olfactory termini, are generally stated to have only indirect nervous connections. I have elsewhere suggested the possibility that in the case of these sense organs the original proton is to be found in the same paired bands of cells from which the olfactory

epithelium is derived. It is admitted that to these other elements have possibly been added by way of the gill clefts, but it seems only natural to suppose that the palatal portion, at any rate, may have had the origin suggested. If this were so, it is evident that there is no relation between the position of the peripheral proton and the source of the nerves supplying these organs. It might be suggested, therefore, that the original nervous communication having been lost, the new connection has been established in a secondary manner by the apposition of what at one time were free termini between the cells to these specialized cells. If the illustration chosen appears far-fetched, a more general illustration will indicate still more clearly the application of theory proposed. There can be no doubt that, on any theory of evolution of the higher vertebrates from the lower, a difficulty arises in the attempt to construe the fact that the lateral line organs with their homologues and allies do not seem to obey a constant law of nervous supply, while in the higher vertebrates it is difficult to follow the transformations which these organs have undergone. It is possible that these difficulties will largely disappear if the probability be admitted that, in the course of evolution, the original connections have been lost or diverted and that new ones have then been established by the application of some of the free nerve endings to the cells thus deprived of their original nervous connections. That some such changes have taken place seems to the writer more than probable. If this be admitted, it is not to be wondered at that in the lower vertebrates especially the two sorts of endings may be encountered side by side in different parts of the skin. It is not the present intention to enlarge on or illustrate this thought, which is thrown out in the hope that the suggestion may prove fruitful in the hands of others.

C. L. HERRICK.

UNIVERSITY OF NEW MEXICO.

##### THE EXHIBITION OF CETACEANS BY PAPIER MACHÉ CASTS.

TO THE EDITOR OF SCIENCE: Mr. F. A. Lucas calls my attention to the following passage in an editorial notice of the new Cetacea Gal-

lery in the British Museum, in the July number of *Natural Science* (p. 10):

"No museum has hitherto solved the difficulty of exhibiting the outward form of the various kinds of whales which baffle the taxidermist's art on account of the oily nature of their skin. At last, however, Sir William Flower has solved the problem in a most satisfactory manner, and the result is a unique addition to the Department of Zoology in the museum over which he presides."

The solution referred to consists in exhibiting *papier maché* casts of one-half of the exterior of the various cetaceans, colored as in life, and placing the skeletons in the concavities of the casts.

Sir William Flower would, I am sure, disclaim originality for this excellent mode of exhibiting cetaceans, as it has been in use in the National Museum for more than fifteen years. In the Report of the Smithsonian Institution for 1882 (p. 125) will be found the following statement:

"Mr. Joseph Palmer, chief modeller, has been engaged during a large part of the year in mounting the skeleton and cast of a humpback whale, 33 feet in length, which now stands in the south main hall. This is the largest cast of an animal that has yet been made, and is unique in conception. Viewed from the left side, the visitor sees the cast of a whale in the attitude of swimming through the water. Standing on the right, he sees the concavity and inner outline of the half cast, in which against a suitable background is mounted the articulated skeleton of the animal."

This interesting specimen is now in the south hall of the Museum, where it has been exhibited since 1882. The idea of showing exterior and skeleton together originated, I believe, with Professor Baird, who took great interest in the specimen referred to, and never failed to point it out to his friends when passing through the Museum.

The Museum has a large series of painted casts of the smaller cetaceans, some of which were made as early as 1874, and a number of replicas were shown at the Berlin Fisheries Exhibition in 1880 and were afterwards taken to London at the time of the Fisheries Exhibition

in 1888. Some of these, if I remember correctly, were left in the British Museum by Dr. Goode at the close of the latter exposition.

FREDERICK W. TRUE.

U. S. NATIONAL MUSEUM,

July 11, 1898.

#### SCIENTIFIC LITERATURE.

*A Treatise on Magnetism and Electricity.* By ANDREW GRAY, LL.D., F.R.S., Professor of Physics in the University College of North Wales. Macmillan & Co. 1898.

The first volume of this treatise awakens a strong desire in us to see the second volume which is promised. The author in his preface states that his effort has been to produce not a work on the mathematical theory of electricity merely, but also to describe the fundamental phenomena, and "to show how they fall into their places in the general scheme of electrical action, and to point out the consequences to which they lead."

There have been many attempts to simplify and amplify Maxwell's great work, and the student now has various aids to enable him to comprehend it, which were not accessible twenty years ago. A distinguished professor of physics once pointed out to me two editions of Maxwell's book, worn and dilapidated by constant use, and remarked: 'I am proud of them.' That treatise certainly contained strong food. Long grappling with it and night oil burned in studying it led to a certain grip of the subject, the evidence of which we see in such books as Professor Gray's. The student now has Poincaré's treatise; Helmholtz's lectures on the electrodynamic theory of light, Drude's *Physik des Ethers*; Oliver Heaviside's work; Professor J. J. Thomson's *Electricity and Magnetism*, Hertz's *Modification of Maxwell's fundamental equations*, Webster's *Electricity and Magnetism*, and the work before us.

A critic should carefully examine the aim of the author and should not take him to task for omissions that were made designedly, and should not endeavor to instruct him in regard to what he should have done, but rather should aim at weighing what has been accomplished. One should, therefore, carefully read Professor Gray's preface, and heed its words in regard to



the limits to which he has confined himself. One will find in this work a strong appreciation of the remarkable papers of Oliver Heavyside and valuable chapters on the Elements of Hydrodynamics. Teachers will highly appreciate the introduction of such chapters in a work on electricity, for one of the principal difficulties in reading Maxwell's book arises from his obscure use of hydrodynamical equations. Indeed, I am tempted to regard this portion of Professor Gray's book as the most valuable to the student, leading him to see the importance in the modern treatment of electrical theories, of hydrodynamics, and compelling him to grapple with Lamb's classical work on this subject.

The author has embodied without essential change Hertz's mathematical discussion of electric waves, and further discussion of this subject is promised in the second volume. We, therefore, cannot venture to criticise his treatment of this subject. It is evident that he intends his treatment of this growing subject to be a full one, for the first volume before us contains Lorentz's remarkable theoretical prediction of Zeeman's discovery of the doubling and tripling of spectral lines in the magnetic field. We know of no other text-book at present which has incorporated the work of Lorentz, or one which contains such a well digested account of the fundamental equations of the electro-dynamical theory of light. We confess to a certain feeling of disappointment at the author's treatment of electrostatics and of the vexed subject of displacement currents; perhaps in the imperfect state of our knowledge no better or fuller treatment is possible. Possibly the second volume will contain an analysis of Professor J. J. Thomson's theory of polarization and tube of force, and of Helmholtz's theory of ions.

The author has selected fundamental experiments with care, and the practical electrician will find much apart from the mathematical treatment which will interest him, notably a full account of Lord Kelvin's mariner's compass. A young electrical engineer who studied Maxwell's treatise with me ten years ago told me that when he first entered into the employment of a great electrical firm he was afraid to leave his copy of Maxwell where it might be

seen, for fear that he would be considered a man in the clouds, unfitted by the study of mathematical theories to cope with practical problems of electricity. He now, however, leaves his copy boldly on his desk and in the workshop. Such has been the advance in the study of electricity among the new schools of electricians. And probably a copy of Professor Gray's treatise will be seen in the workshop along side that of Maxwell.

JOHN TROWBRIDGE.

*Review and Bibliography of the Metallic Carbides.*

By J. A. MATHEWS. Smithsonian Miscellaneous Collections, 1090. City of Washington, 1898. 8vo. Pp. 32.

The Chemical Section of the American Association for the Advancement of Science in 1882 appointed a Committee on Indexing Chemical Literature, and in 1884 the Chairman of that Committee reported an agreement entered into with the Smithsonian Institution whereby the latter consented to publish Indexes to Chemical Literature upon recommendation of the Committee. The booklet under review forms one of this series. Mr. Mathew's plan has much to approve; he gives a synopsis of the methods of preparation, physical and chemical properties of the known carbides, considering them in alphabetical order, and following each are the references to the literature bearing thereon.

Examination of this review shows that Henri Moissan has contributed more to our knowledge of the metallic carbides during the last five years, thanks to his electric furnace, than all chemists had done in previous years. The production of acetylene gas from calcium carbide seems to have been announced first by Wöhler in 1862. No commercial use was made of this fact, however, until about 1893, when the Willson Aluminum Company, in this country, while experimenting upon the reduction of the alkali earths by means of carbon, found that calcium carbide was formed; this was regarded as a waste product until its properties of readily decomposing with water and yielding acetylene gas established its commercial value. Mr. Mathews, writing in 1897, says: "The cost of production is still rather high and the chances of acetylene gas being generally introduced for lighting pur-



poses in the immediate future are not very bright."

In a postscript to the Review the author gives the literature down to March, 1898, which includes no less than eight books on the subject published in Europe.

It is unfortunate that Mr. Matthews uniformly omits initials of authors' names, for Berzelius, Wöhler and Moissan this is well enough, but we notice the names of Brown, Clarke and Jones, who certainly need initials. However, the Review is a welcome addition to chemical bibliography.

H. C. B.

*Brown Men and Women, or the South Sea Islands in 1895 and 1896.* By EDWARD REEVES. London, Swan, Sonnenschein & Co. 1898. With sixty illustrations and a map. Pp 294.

The author of this account was born in New Zealand, and from early days was acquainted with the peoples of the Pacific island-world. In 1895-6 he made two voyages to several of its archipelagoes, the Friendly Islands, the Samoan, Fijian, Society and Cook groups, jotting down his observations and clicking his camera as occasion offered. His attention was especially attracted by the social condition and prospects of the native population. This he claims to depict with more accuracy and a better knowledge than most previous writers.

The result may be briefly stated. He considers that they would be far better off if European civilization, and especially the Christian religion, were not forced upon them. His particular antipathy is the missionary. That wandering worthy he regards as the evil genius of Polynesia, and he repeatedly urges that subscriptions to 'foreign missions' should be stopped once for all. There is little of interest in the ethnographic observations, although the author must have had good opportunities.

D. G. BRINTON.

*Memory and its Cultivation.* By F. W. EDRIDGE-GREEN. New York, D. Appleton & Co. 1897. Pp. 307.

The author of this book says in his preface: "After discovering the facts which led me to write on the subject of memory, I found that

I could learn a subject in about a fifth of the time that it previously took me." As he could have done it so easily, it is a pity that he did not learn something about psychology and physiology before attempting to write on these subjects. It is scarcely necessary for the scientific reader to go further than the frontispiece to understand the character of the book. This is a queer looking section of the brain, showing the 'center of sensory memory' and the 'center of motor memory' in the basal ganglia connected with the 'seat of the faculties of the mind' in the cortex. Further on we are told that there are thirty-seven of these faculties. Parental love is a faculty, but not conjugality, because 'conjugality is not likely to influence a man who hates his wife.' The book contains the stock anecdotes and mnemonic devices that may be picked up from desultory reading, and the author would doubtless pass for a man of wide information and agreeable parts in ordinary society. But it is a mystery why such a book should be published, as the last volume of the 'International Scientific Series'—a series which has maintained such a high standard and includes so many important scientific works.

J. McKEEN CATTELL.

#### SOCIETIES AND ACADEMIES.

ACADEMY OF NATURAL SCIENCES, PHILADELPHIA, JULY 5, 1898.

MR. BENJAMIN SMITH LYMAN referred to the belief that chlorophyl required light for its production and exhibited an onion which in the course of seven months, without special nourishment, had grown long, green shoots in a dark closet. A potato in the same closet had sent out sprouts, but they contained no chlorophyl.

PROFESSOR HENRY A. PILSBRY communicated the results of his recent study of the molluscan group Aplacophora, dwelling specially on the characters distinguishing it from the gastropods. The former were first believed to be worms, but the discovery of a radula in the gullet and of a nervous system like that of the Chitons places them among the mollusks. They have a straight alimentary canal, while in the Chitons it is twisted and coiled. Although

living in mud, the Aplacophora are not mud feeders. The loss of the foot and shell is probably accounted for by their habitat. All the known species are European, not a single form having been recorded from the coasts of the United States, although it is quite likely they exist there.

Papers under the following titles were presented for publication: 'Contributions to Tropical Herpetology,' by Robert Baird McLain; 'Critical Notes on a Collection of Reptiles from the Western Coast of the United States,' by Robert Baird McLain; 'The Eastern Reptiles in the Collection of the Museum of the Stanford University Zoological Department,' by Robert Baird McLain.

EDWARD J. NOLAN,  
Recording Secretary.

TORREY BOTANICAL CLUB, MAY 25, 1898.

THE evening was devoted to discussion and exhibition of acaulescent purple violets, introduced by a paper on 'The Acaulescent Violets,' by Mr. C. L. Pollard, of Washington, D. C., read by Dr. Hollick. This paper, soon to be printed, was the result of field study of the last two years, mainly in the Middle States, from which States most of our original species-types were derived. Mr. Pollard now describes 18 species and 3 varieties. He remarked that for violet characters we must depend upon unremitting field work. Herbarium material is useless, except as fortified by previous familiarity with the appearance while growing. Large numbers of individuals must be studied and every feature of the environment must be noted. Careful attention must be given not only to habit, but to habitat, to texture of herbage, to color of the flowers, to position of the cleistogenes, to nervation, to shape and pubescence of leaves, and to the nature of the surrounding vegetation.

A series of mounted specimens illustrating this paper was exhibited by Dr. Britton, and a large number of fresh specimens were passed, the result of collections sent in by Miss Sanial and by Messrs. Rusby and Crawford, and by Drs. Rusby and Hulst.

Discussion of the Eastern, stemless violets followed, in which Dr. and Mrs. Britton, Dr.

Rusby, Mr. Bicknell and the Secretary participated.

Dr. Rusby referred to a very small and apparently unique violet collected by him at Franklin, N. J., some years since, distributed by him as *Viola cucullata cordifolia* of Gray, and remarkable because only about one inch high.

Mr. Howe, in behalf of Professor Lloyd, its discoverer, exhibited the original specimen of *V. MacCloskiei* Lloyd, from the State of Washington.

Mr. Bicknell spoke of the confluence of many surely distinct violet species.

Dr. Britton said that, while a number of violet species are clearly isolated in character, there is every gradation from these to the more critical species. The latter show all kinds of intermingling. The tendency to atavism, especially in the earlier, not maturely formed leaves, is very strong and often suggests the paternity of a species.

Dr. Britton announced that about 25 violet species are now growing at the botanic garden.

After much discussion of the characters on which Mr. Pollard's species rest, the Club was adjourned to the second Tuesday in October.

EDWARD S. BURGESS,  
Secretary.

#### NEW BOOKS.

*Vorlesungen über Theoretische Physik.* H. VON HELMHOLTZ. Band I., Abtheilung 2 Vorlesungen über die Dynamik discreter Massenpunkte. Edited by OTTO KRIGAR MENZEL. Band III., Vorlesungen über die Mathematischen Principien der Akustik. Edited by ARTHUR KÖNIG and CARL RUNGE. Leipzig, J. A. Barth. 1898. Pp. x + 380 and x + 256.

*Practical Plant Physiology.* W. DETMER. Translated by S. A. MOOR from the second German edition. London, Swan Sonnenschein & Co., Ltd.; New York, The Macmillan Co. 1898. Pp. xix + 555. \$2.

*Proceedings of the American Association for the Advancement of Science.* Forty-sixth Meeting, held at Detroit, Mich., 1897. Salem, The Permanent Secretary. 1898. Pp. xxx + 499.

# SCIENCE

EDITORIAL COMMITTEE: S. NEWCOMB, Mathematics; R. S. WOODWARD, Mechanics; E. C. PICKERING, Astronomy; T. C. MENDENHALL, Physics; R. H. THURSTON, Engineering; IRA REMSEN, Chemistry; J. LE CONTE, Geology; W. M. DAVIS, Physiography; O. C. MARSH, Paleontology; W. K. BRÖOKS, C. HART MERRIAM, Zoology; S. H. SCUDDER, Entomology; C. E. BESSEY, N. L. BRITTON, Botany; HENRY F. OSBOEN, General Biology; C. S. MINOT, Embryology, Histology; H. P. BOWDITCH, Physiology; J. S. BILLINGS, Hygiene; J. McKEEN CATTELL, Psychology; DANIEL G. BRINTON, J. W. POWELL, Anthropology.

FRIDAY, JULY 29, 1898.

A MEMENTO OF PROFESSOR EDWARD D. COPE.

## CONTENTS:

<i>A Memento of Professor Edward D. Cope:</i> PROFESSOR CHARLES S. MINOT .....	113
<i>Recent Experiments on Certain of the Chemical Elements in Relation to Heat:</i> PROFESSOR W. A. TILDEN .....	114
<i>Preliminary Note on the Growth of Plants in Gypsum:</i> T. D. A. COCKERELL .....	119
<i>The Cross-ratio Group of 120 Quadratic Cremona Transformations of the Plane:</i> DR. H. E. SLAUGHT .....	121
<i>The Conference of Science Teachers in the Trans-Mississippi Educational Convention:</i> PROFESSOR CHARLES E. BESSEY .....	123
<i>Current Notes on Anthropology:—</i>	
<i>The Beginnings of Mind; Mushroom-shaped Images; American Indian Games:</i> PROFESSOR D. G. BRINTON .....	126
<i>Scientific Notes and News:—</i>	
<i>Preventive Inoculation against Plague; An Exhibit of the History of Medicine; General</i> .....	127
<i>University and Educational News</i> .....	132
<i>Discussion and Correspondence:—</i>	
<i>Miocene Edentates:</i> PROFESSOR S. W. WILLISTON .....	132
<i>Scientific Literature:—</i>	
<i>Binet and Henri on La fatigue intellectuelle; Professor Joseph Jastrow. Engler's Syllabus der Pflanzenfamilien:</i> PROFESSOR L. M. UNDERWOOD. <i>Ziegler's Text-book of Special Pathological Anatomy:</i> PROFESSOR SIMON FLEXNER .....	132
<i>Societies and Academies:—</i>	
<i>Zoological Club of the University of Chicago:</i> V. E. McCASKILL, DR. C. M. CHILD .....	140
<i>New Books</i> .....	140

DURING the winter of 1894 Professor Cope visited my laboratory, and we had a somewhat prolonged discussion of evolutionary problems. During this conversation I asked him concerning his views as to the actual phylogeny of the mammalia. This led to his writing down on a large sheet of paper the interesting table of descent which is herewith reproduced in facsimile (p. 114).

It was written out under the guidance of question and answer, but I think it will be clear in spite of some apparent confusion. The groups Sirenia and Cetacea he would express no opinion about, and they were jotted down where there happened to be space on the paper, but with no indication of their affinities. In response to a question concerning the Proboscidea he declared that they had no close affinity with the Anthropoid group, which he marked off with an irregular line which collates in one group the Anthropeida and Condylartha. A similar question in regard to the Cheiroptera led to a line being added to separate the Cheiroptera from a group which comprises the Insectivora, Creodonta, Fillodonta and Tæniodonta. Professor Cope considered the mammalia as of single and not multiple descent. Of course, he did not regard the living Marsupials and Mono-

MSS. intended for publication and books, etc., intended for review should be sent to the responsible editor, Professor J. McKeen Cattell, Garrison-on-Hudson, N. Y.

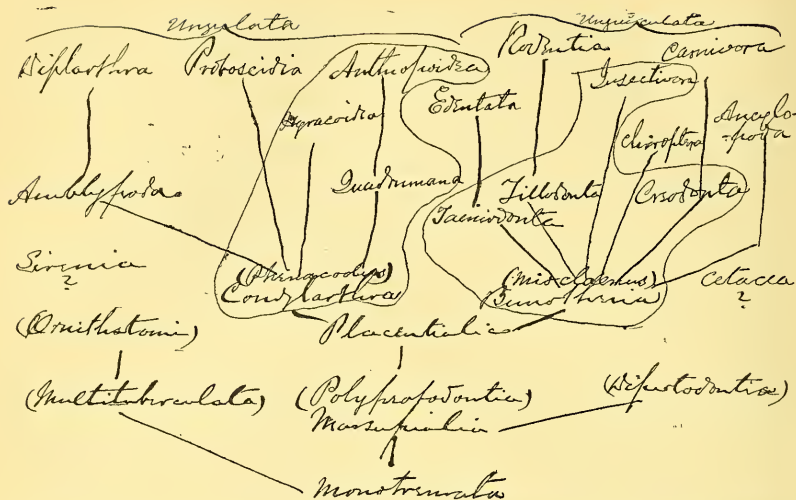

tremes as true surviving ancestral types, as the table might seem to suggest.

It is merely justice to him to add that he regarded the whole subject as a problem for further investigation, and that he by no means looked upon his own conceptions at that time as final. CHARLES S. MINOT.

RECENT EXPERIMENTS ON CERTAIN OF THE  
CHEMICAL ELEMENTS IN RELATION TO  
HEAT.\*

THE discovery that different substances have different capacities for heat is usually attributed to Irvine, but there can be no doubt that Black, Crawford and others contributed to the establishment of the idea. The fact that equal weights of different substances, in cooling down through the same number of degrees, give out different amounts of heat, may be illustrated by the well-known experiment in which a cake of

wax is penetrated with different degrees of rapidity by balls of different metals heated to the same temperature. But, for the quantitative estimation of the amounts of heat thus taken up and given out again—that is, the *specific heats*—the physicist must resort to other forms of experiment, each of which presents difficulties of its own. Broadly speaking, three principal methods have been used in the past for this purpose. The first is based upon the observation of the exact change of temperature produced in a known mass of water, by mixing with it a known weight of the substance previously at a definite temperature above or below that of the water. The second consists in determining the quantity of ice melted, when the heated body is brought into contact with it in such a way that no heat from any other source can reach the ice. And the third method consists in observing the rate at which the temperature of the heated body falls through a definite range of degrees, when suspended in a vacuum

\*A Lecture delivered before the Royal Institution of Great Britain on May 13, 1893, by Professor W. A. Tilden, D.Sc., F.R.S.



space, as compared with the rate of cooling of another body taken as the standard.

The process of intermixture with water was used by the earlier experimenters in the last century, and some of the best results extant have been obtained by this method, which, however, is not so easy as it appears when the highest degree of accuracy is desired.

Lavoisier and Laplace, in 1780, devised the ice calorimeter which bears their name; and in a most interesting memoir, which is reprinted among Lavoisier's works, they show that they were familiar with the idea which in modern times is expressed as the principle of the conservation of energy. In this memoir they give the results of experiments, in which the specific heats of iron, mercury and a few other substances are estimated with a very tolerable approach to

Dulong and Petit\* seem to have used at first the method of mixtures, and to have found, by direct experiment, that the specific heat of solids (metals and glass) increases with the temperature. They also studied (after Leslie) the laws of cooling of bodies; and two years after the publication of their first paper on the subject they (Petit and Dulong, *sic*) arrived at the remarkable general expression which is associated with their names.†

After pointing out that all the results of previous experiments except those of Lavoisier and Laplace are extremely incorrect they describe their own conclusions obtained by the method of cooling, conducted with many precautions to avoid error. The numerical expression of their experimental results is given in the following table:

COPY OF TABLE BY PETIT AND DULONG.

(Ann. Chim. Phys. 1819, X., 403.)

—	Specific Heats.	Atomic Weights (0 = 1).	Atomic Weight × Specific Heat.
Bismuth .....	.0288	13.30	.3830
Lead .....	.0293	12.95	.3794
Gold .....	.0298	12.43	.3704
Platinum .....	.0314	11.16	.3740
Tin .....	.0514	7.35	.3779
Silver .....	.0557	6.75	.3759
Zinc .....	.0927	4.03	.3736
Tellurium .....	.0912	4.03	.3675
Copper .....	.0949	3.957	.3755
Nickel .....	.1035	3.69	.3819
Iron .....	.1100	3.392	.3731
Cobalt .....	.1498	2.46	.3685
Sulphur .....	.1880	2.011	.3780

accuracy. Although many of the metals were known to them, and supposing they had persisted in this work, it would not have been possible for them to make the discovery which was reserved for Dulong and Petit thirty-five years later, for the atomic theory had not then been conceived, and no elemental combining proportions had been determined.

The statement of the relation indicated in the last column of figures is expressed in the following words of the authors, page 405: "Les atomes de tous les corps simples ont exactement la même capacité pour la chaleur."

Here the question rested, till resumed

\* Ann. Chim., 1817, VII., 144.

† *Ibid.*, 1819, X., 395.

many years later (1840) by Regnault, who in his first memoir\* pointed out the difficulties which attend the acceptance of the statement of Petit and Dulong in the form in which they gave it. He then discussed the three principal experimental methods: viz. (1) fusion of ice; (2) mixture with water or other liquid; and (3) cooling; and decided in favor of the second, which he used throughout his researches. The general form of the apparatus used by the great physicist has been a model for the guidance of successive experimentalists since his time.

Another quarter of a century elapsed before the question of the specific heats of the elements was resumed by Hermann Kopp. His results were communicated to the Royal Society, and are embodied in a paper printed in the *Philosophical Transactions* for 1865. After reviewing the work of his predecessors he described a process by which he had made a large number of estimations of specific heat, not only of elements, but of compounds of all kinds in the solid state. Concerning his own process, however, he remarks that "The method, as I have used it, has by no means the accuracy of that of Regnault" (p. 84).

In 1870 Bunsen introduced his well-known ice-calorimeter. This is an instrument in which the amount of ice melted by the heated body is not measured by collecting and weighing the water formed, but by observing the contraction consequent upon the change of state. The results obtained by Bunsen himself are uniformly slightly lower than those of Regnault for the same elements.

Since that time experiments have been made by Weber, Dewar, Humpidge and others, in connection especially with the influence of temperature in particular cases.

Setting aside the elements, carbon, boron, silicon and beryllium, as providing an en-

tirely separate problem, the question is whether the law of Dulong and Petit is strictly valid when applied to the metals. Kopp, in the discussion of his subject, came to the conclusion that it is not; but the grounds for this conclusion are unsatisfactory, since neither the atomic weights nor the specific heats were at that time known with sufficient accuracy. It has been customary to assume that the divergences from the constant value of the product,  $At. \text{Wt.} \times \text{Sp. Ht.}$  are due partly to the fact that at the temperature at which specific heats are usually determined, the different elements stand in very different relations to their point of fusion; thus, lead at the temperature of boiling water is much nearer to its melting point than iron under the same conditions. The divergences have also been attributed to temporary or allotropic conditions of the elements. As to the relation to melting point, the specific heats of atomic weights seem to be practically the same in separate metals and alloys of the same which melt at a far lower temperature. For example, the atomic heat of cadmium is 6.35; of bismuth, 6.47; of tin, 6.63; and of lead, 6.50; while the mean atomic heat in alloys of bismuth with tin, and lead with tin, ranges from 6.40 to 6.66 (Regnault), which is practically the same. Again, while the melting point of platinum is at a white heat, the metal becomes plastic at a low red heat, and yet the specific heat at this lower temperature is very little less than it is near the melting point. The properties of many other metals, notably zinc and copper, change considerably at temperatures far removed from their melting points without substantial change in their capacity for heat.

As to allotropy, it is a phenomenon which is comparatively rare among metals, and in the marked cases in which it occurs we have no information as to the value of the specific heats in the several varieties, such

\*Ibid., 73, 5.

as the two forms of antimony and the silver-zinc alloy of Heycock and Neville, and they may be left out of account. Bunsen compared the so-called allotropic tin, obtained by exposing the metal to cold for a long time, and found it .0545 against .0559 for the ordinary kind.\* In dimorphous substances there is often no difference. Regnault found for arragonite .2086 and for calcite .2085 respectively. The differences between metals hammered and annealed, hard and soft, were also found by Regnault to be very small.†

Hard steel ... .1175. Same, softened ... .1165.  
 Hard bronze ... .0858. Same, softened ... .0862.

Kopp came to the conclusion, *first* that each element in the solid state, and at a sufficient distance from its melting point, has *one* specific or atomic heat, which varies only slightly with physical conditions; and *secondly*, that each element has essentially the same specific or atomic heat in compounds as it has in the free state. This last is practically identical with the statement which is known as Neumann's law. With Kopp's conclusion I agree, but from some of Regnault's results, coupled with my own, the effect of *small* quantities of carbon, and perhaps of sulphur, upon the specific heats of metals is greater than has been supposed. If we take the results of Regnault and of Kopp and combine them with the most accurately known atomic weights the products are still not constant.

The 'Law' of Dulong and Petit is therefore only an approximation; but this may perhaps be due to inaccuracy in the estimation of the specific heat, owing to impurity in the material used. That is the problem which I have endeavored to solve.

The introduction by Professor J. Joly of a new method of calorimetry, which depends upon the condensation of steam upon the cold body, and the excellent results obtained by the author in the use of the differential form of his instrument,‡ led me to think that with due attention to various precautions—such as exact observations of the temperatures, and practice in determining the moment at which the increase of weight due to condensation is completed—results of considerable accuracy might be obtained.

The problem is to find two elements, very closely similar in density and melting point, which can be obtained in a state of purity, and then to determine with the utmost possible accuracy the specific heat of each under the same conditions.

The two metals cobalt and nickel were selected for the purpose. They were examined by Regnault, but the metals he used were very impure.

The cobalt employed in my experiments was prepared by myself. For the nickel I am indebted to Dr. Ludwig Mond. Both were undoubtedly much more nearly pure than any metal available in Regnault's time. The results obtained are as follows:

ATOMIC WEIGHTS MOST ACCURATELY KNOWN (1897) COMBINED WITH SPECIFIC HEATS.

	A. W. (H=1).	S. H. Regnault.	S. H. Kopp.	At. Ht. Regnault.	At. Ht. Kopp.
Copper .....	63.12	.09515	.0930	6.01	5.87
Gold.....	195.74	.03244	....	6.35	....
Iron.....	55.60	.11379	.1120	6.33	6.23
Lead.....	205.36	.03140	.0315	6.45	6.47
Mercury liq.....	198.49	.03332	....	6.61	....
"    —79° to +10° sol.....	198.49	.03192	....	6.34	....
Silver.....	107.11	.05701	.0560	6.11	6.00
Iodine.....	125.89	.05412	....	6.81	....

\* Pogg Ann. 141, 27.

† Ann. Chim. [3], IX.

‡ Proc. R. S. 47, 241.

## SPECIFIC HEATS OF COBALT AND NICKEL.

*Pure fused.*

Cobalt, S. G. $\frac{21^\circ}{4^\circ}$ 8.718.	Nickel, S. G. $\frac{21^\circ}{4^\circ}$ 8.790.
.10310	.10558
.10378	.10610
.10310	.10630
.10355	
.10373	
.10362	
Arith. mean . . . . . 10848	.10931

The value arrived at for cobalt is much lower than that (.1067) derived from Regnault's experiments, while that for nickel is practically identical with Regnault's, which is .1092. This is certainly too high.

Further experiments will be made, because a single well-established case of this kind is sufficient to decide the question. Already, however, I feel certain that Kopp's conclusion is right, and that the law of Dulong and Petit, even for the metals, is an approximation only and can not be properly expressed in the words of the discoverers. For, although the exact values of the atomic weights of these two elements, cobalt and nickel, are not known, it is certain that they are not so far apart as would be implied by these values for the specific heats.

Two other examples of somewhat similar kind are shown by gold and platinum, copper and iron.

For the gold I naturally applied to my colleague, Professor Roberts-Austen. The platinum I prepared from ordinary foil, by resolution and re-precipitation as ammoniochloride and subsequent heating. Both metals were fused into buttons before use. The atomic heats come closer together than those of Co and Ni.

Copper and iron differ considerably in melting point, but both at the temperature of 100° are far removed from even incipient fusion. The copper was prepared from pure sulphate by electrolysis, the iron by reduction of pure oxide in pure hydrogen. Notwithstanding all our care, it was disappointing to find it contained .01 per cent. of

carbon, the source of which I am at a loss to explain. This iron is purer than any examined by Regnault or Kopp.

## SPECIFIC HEATS OF GOLD AND PLATINUM.

*Pure fused.*

Gold, S. G. $\frac{18^\circ}{18^\circ}$ 19.227.	Platinum, S. G. $\frac{18^\circ}{18^\circ}$ 21.323.
.03052	.03147
.03017	.03159
.03035	.03144
Arith. mean . . . . . 0.03035	Arith. mean . . . . . 0.03147
Atomic heat . . . . . 5.94	Atomic heat . . . . . 6.05

## SPECIFIC HEATS OF COPPER AND IRON.

*Fused.*

Copper (pure) S. G. $\frac{20^\circ}{20^\circ}$ 8.522.	Iron, S. G. $\frac{15^\circ}{15^\circ}$ 7.745, contains 0.01 per cent. carbon
.02248	.11022
.02241	.11037
.02205	
.02234	Arith. mean . . . . . 1.1039
Arith. mean . . . . . 0.02232	Atomic heat . . . . . 6.13
Atomic heat . . . . . 5.83	

The differences observed between cobalt and nickel, and between gold and platinum, are manifestly not due to allotropes or to differences of melting point, which in these cases can have no effect on the result. So large a difference must be due to peculiarities inherent in the atoms themselves; and differences of atomic heat are to a certain extent comparable with the differences observed in other physical properties, which, like specific volume, specific refraction, etc., are approximately additive.

If we try to think what is going on in the interior of a mass of solid when it is heated, the work done is expended not only in setting the atoms into that kind of vibration which corresponds to rise of temperature, that is, it makes them hotter, but partly in separating the molecules or physical units from one another (= expansion) and partly in doing *internal* work of some kind, the nature of which is not known. A difference between metals and non-metals has been brought out by the researches of Heycock and Neville, who find that metals dissolved in metals are generally monatomic; whereas it is generally admitted that iodine, sulphur and phosphorus in solution are polyatomic. It is moreover remarkable that,



although in respect to specific heat each element in a solid seems to be independent of the other elements with which it is associated, when the elementary substances are vaporized some rise in separate atoms like mercury, some in groups of atoms like iodine, sulphur, arsenic and phosphorus, and as the temperature is raised these groups are simplified with very varying degrees of readiness.

The two metals, cobalt and nickel, with which I began my inquiry, have very nearly the same atomic weight, the value, 58.24 for nickel and that for cobalt 58.49, being calculated by F. W. Clarke from the results of a great many analyses by many different chemists. They are so close together that for a long time they were regarded as identical, and Mendeléef does not hesitate even to invert the order by making Co = 58.5 and Ni = 59. These metals, nevertheless, differ from each other in several very important chemical characters. Nickel, for example, forms the well known and highly remarkable compound with carbonic oxide discovered by Dr. Mond. Cobalt, on the other hand, produces many amino-compounds to which there is nothing corresponding among the compounds of nickel.

Having put aside the common excuses for the observed divergences from the constant of Dulong and Petit, we are compelled to look round for some other hypothesis to explain them.

The constitution of carbon compounds is now accounted for by a hypothesis concerning the configuration of the carbon atom introduced by Van't Hoff and LeBel twenty-five years ago, and which is now accepted by the whole chemical world. It seems not unreasonable to apply a similar idea to the explanation of those cases of isomerism which have been observed in certain compounds of the metals, notably chromium, cobalt and platinum. This has already been done by Professor Werner, of Zurich. If the

constitution of compounds can be safely explained by such hypothesis, this implies the assumption of peculiarities in the configuration of the individual constituent metals around which the various radicles are grouped in such compounds; and hence peculiarities in the behavior of such metals in the elemental form may possibly be accounted for. For the atom of cobalt Professor Werner employs the figure of the regular octahedron. For nickel, therefore, which differs from cobalt in many ways, a different figure must be chosen. This, however, is for the present a matter of pure speculation.

PRELIMINARY NOTE ON THE GROWTH OF PLANTS IN GYPSUM.

In the 'Handbook of Experiment Station Work' (1893), p. 176, the following passage occurs:

"The action of gypsum as a fertilizer is not well understood. It appears to act indirectly in the soil, setting free plant food, especially potash, already present, but contributing little directly to the support of plants \* \* \* It also promotes nitrification. Gypsum is used as an absorbent in manure heaps to prevent loss of ammonia."

Nevertheless, plants will grow in nearly pure gypsum, as we propose to show.

On the east side of the San Andreas mountains, in southern New Mexico, is an immense deposit of white sand, which has the following composition, according to data kindly furnished by Mr. R. F. Hare, assistant chemist of the New Mexico Experiment Station:

CaSO <sub>4</sub> + 2 H <sub>2</sub> O (Gypsum).....	97.00	per cent.
CaCO <sub>3</sub> (Calcium Carbonate).....	2.86	" "
MgCO <sub>3</sub> (Magnesium Carbonate)...	.06	" "
MgSO <sub>4</sub> (Magnesium Sulphate).....	.12	" "
K <sub>2</sub> SO <sub>4</sub> .....	.07	" "
Na <sub>2</sub> CO <sub>3</sub> .....	trace.	
NaCl.....	trace.	

In this deposit, locally known as the

White Sands, many plants grow and flourish. In Bulletin 22 of the New Mexico Experiment Station, Professor A. Goss gives a good plate showing the edge of the sands, with a *Rhus* and plenty of grass growing on the slope. On October 6, 1896, a few plants were obtained from the White Sands, and these formed the subject of an interesting paper by Miss Alice Eastwood in *Proceedings of California Academy of Sciences*, third series, Botany, Vol. I., No. 2.\* Three of the plants were so modified by their peculiar environment as to constitute new varieties, viz., *Ethiopia* or *Galpisia tubicula* var. *filifolia*, *E.* or *Anogra albicaulis* (*pallida*) var. *gypsophila* and *Bigelovia* (or

- (1.) White Sands, as above.
- (2.) *Larrea*-soil, *i. e.*, soil where the *Larrea* grows, on the bench behind the Agricultural College. It consists of wash from the Organ mountains principally.
- (3.) Mesquite-soil, *i. e.*, soil of the Mesquite zone, the one immediately below the last, also mainly derived from the mountains.
- (4.) *Pluchea*-soil, *i. e.*, sandy soil from the zone of *Pluchea borealis* and the tornillo bush; river alluvium.
- (5.) Adobe soil, from the Station orchard.

The plants were watered with well water, which contains some salts in solution, but not an excessive amount. The tallest plant in each pot was measured at intervals with the following results, given in centimeters:

## WHEAT.

	Feb. 17.	Feb. 26	March 7.	March 14.	March 19.	April 1.	June 11.	Width of leaf blade, Apr. 1.	Diam. of Stalk Apr. 1.
White Sands,	3½	18	23½	28½	34½	41	81	5 mm.	2½ mm.
Larrea,.....	8	22	30½	36	39¾	49	82	6¾ "	2½ "
Mesquite, ...	9	24	35	37	42	49	75½	6¾ "	2¾ "
Pluchea, ....	8	24½	31	34½	40	41	75	6 "	2 "
Adobe, ....	9½	25	37	39	42½	54	78	8½ "	3 "

*Chrysothamnus*) *graveolens* var. *appendiculata*. Two others, *Thelesperma gracile* and *Muhlenbergia pungens*, were not modified.

In 1897 Professor E. O. Wooton collected plants on the White Sands, adding a number of species to the list. Of these, four have at present been published in the *Bulletin of the Torrey Botanical Club*, 1898. They are *Conanthus carnosus*, Wooton, and *Andropogon neomexicanus*, Nash, two new species as yet only known from this locality, and *Sporobolus giganteus* and *S. nealleyi*, not confined to the sands.

On February 7th of the present year we sowed seeds of Feldspar wheat and the Rural New Yorker pea in pots in five different soils in the Experiment Station greenhouse, ten seeds in each pot. The soils were as follows:

\* In this paper it is stated in error that the plants were gathered in August.

The data of April 1st are the best, as they include measurements of the leaf and stalk. It will be seen that on June 11th the gypsum wheat actually out-topped that from the adobe soil (which previously was the best), but it was found that during the latter part of the experiment the roots from each pot have grown downwards so as to form a mat in the soil on which the pots were placed, which was of good quality. This resulted from our thoughtlessly transferring the pots from the bench, where they had stood, to the floor of the greenhouse to make way for some other plants.

On June 11th the wheat was all ripe except one or two very small heads in all the pots except the gypsum one, which still had six or seven green heads. The ripe ears were gathered, and we got this result:

(1) White Sands, 9 ears, weighing 10.38 grams, containing 283 grains, weighing 7.310 grms.					
(2) Larrea, 10 " " " 9.77 " " " 243 " " 6.995 "					
(3) Mesquite, 10 " " " 10.60 " " " 285 " " 7.610 "					
(4) Tornillo, 10 " " " 11.83 " " " 330 " " 8.270 "					
(5) Adobe, 10 " " " 10.24 " " " 254 " " 7.335 "					

## PEAS (Measurements in cm.).

	Feb. 26.	Mar. 7.	Mar. 14.	Mar. 19.	Apr. 1.
White Sands,	12.	27.	38.	48.	57.
Larrea,	13½.	25½.	27½.	36.	51.
Mesquite,	11½.	25.	31.	38.	42.
Pluecha,	13½.	29½.	36.	47.	53.
Adobe,	12½.	23½.	26.	35½.	54.

No. 1 and 4 were not perfectly ripe, and may owe a very little of their weight to the extra moisture they contain. It will be seen that the gypsum wheat weighs up well with the others, and when its green heads, above mentioned, are ripe the product will outweigh considerably all of the others.

It is seen from the table that the gypsum peas are decidedly the best. We could not measure the yield (the gypsum peas were the first to bloom, on March 19th), because certain girls of the class in horticulture saw fit to remove some of the pods when unobserved by their professor.

CONCLUSIONS.—It appears, from these preliminary researches, that nearly pure gypsum will nourish plants as well as ordinary soil, or even better. It is not apparent how the wheat, etc., come by their nitrogen in such a soil, though the peas may well get it by means of their root-tubercles. The absence of other elements is also noticeable, but it is not worth while at the present time to enter into a detailed discussion of causes and effects, as further researches will, it is hoped, make such a discussion more profitable at a later date.

T. D. A. COCKERELL.

FABIAN GARCIA.

N. M. AGR. EXP. STA.

MESILLA PARK, N. M., June 17, 1898.

THE CROSS-RATIO GROUP OF 120 QUADRATIC  
CREMONA TRANSFORMATIONS OF  
THE PLANE.\*

GROUPS of linear substitutions have long been studied with reference to (1) the geometric representation in the plane or on the sphere, (2) the rational integral functions left invariant under the operators of the group. These questions now prove to be of interest when investigated for groups of transformations of order higher than the first. The theory of birational transformations (quadratic and higher) has been given by Cremona, Cayley, Clebsch and others. Groups of such transformations have been enumerated by Autonne and S. Kantor. The cross-ratio Cremona transformation groups of order  $n!$  were first given by Professor E. H. Moore in his lectures at the University of Chicago in the spring of 1895. These groups are found by determining for each permutation of  $n$  quantities a fundamental system of  $n-3$  cross-ratios in terms of which the cross-ratios of every four out of the  $n$  quantities are expressible, and then setting up the transformation relations among these  $n!$  fundamental systems.

\* Abstract of a Dissertation submitted to the Faculties of the Graduate Schools of Arts, Literature and Science in the University of Chicago, April, 1898, in candidacy for the degree of Doctor of Philosophy (Department of Mathematics), by H. E. Slaught.

The case  $n=5$  gives the group of 120 *quadratic* transformations of the plane which is the subject of the present study. This group contains a *linear* subgroup of order 244! which permutes in all possible ways the four fundamental points of the Cremona group. This subgroup is isomorphic with Klein's linear group of order 4! for which Professor Moore has shown a division of the plane to be given by a certain complete quadrangle (including its diagonals) whose vertices are the four points permuted.

I. This affords a means of finding a geometric representation for our *quadratic* group as follows:

(1) A linear fractional transformation is found which throws the complete quadrangle for the Klein group into another whose vertices are the four fundamental points of the *quadratic* group, and which, therefore, gives the division of the plane for the *linear* subgroup. (2) The linear subgroup is transformed by all the quadratic operators of G120, giving four quadratic subgroups conjugate with the linear subgroup. (3) The division of the plane for these quadratic subgroups differs from that of the linear subgroup only by replacing, each time, the three diagonal lines by certain three conics. (4) The division of the plane for the main group is then given by a composite of the five pictures belonging to these five conjugate subgroups, and consists of the original complete quadrangle together with its diagonals and twelve conics. A further study of the various subgroups shows the following conjugate systems of special lines or points: (1) A system of ten elements consisting of the six sides of the original quadrangle, which are fundamental lines, and the four pencils of 'directions' at the four fundamental points. (2) A system of fifteen lines consisting of the three diagonals and twelve conics. (3) A system of fifteen lines consisting of certain three conics not in the configuration

and twelve 'direction' lines through the fundamental points. (4) Twelve real points at each of which five lines intersect. (5) Fifteen real points where four lines intersect. (6) Twenty imaginary points of three-fold intersection. (7) Thirty real points of two-fold intersection. (8) Twenty imaginary points lying by pairs on the six sides and four pencils. (9) Thirty imaginary points lying by pairs on the three diagonals and twelve conics.

II. The Klein linear group of order 4! also affords the means of finding the invariants of the quadratic group, as follows:

(1) The complete form-system of the linear subgroup comes from the known system for the Klein group by the same transformation which throws the generators of the former group to those of the latter. (2) The most general invariant form of any given degree under the linear subgroup is then set up with arbitrary coefficients and operated upon by the quadratic generator which extends the linear subgroup to the main group. (3) This doubles the degree of the given form, and hence the only possibility for the existence of an invariant under the quadratic group is to so determine the arbitrary constants that a factor in the variables may divide out, leaving the original form. (4) Hence an invariant form under a quadratic operator must be a *rational fraction*, such that a common factor in the variables will cancel from numerator and denominator, leaving the original fraction. (5) It is found that the most general forms suitable for numerator and denominator of invariant fractions of the 6th, 12th and 18th degrees respectively are:

$$\begin{aligned}
 & m A, m_1 A^2 + m_2 P^2, m_1 A^3 + m_2 A P^2 + m_3 C \\
 & \text{when the } m\text{'s are arbitrary constants and} \\
 & A = 2p^2q^2 - 6(p^3r + q^3) + 19pqr - 9r^2 \\
 & P^2 = p^2q^2r^2 - 4(q^3r^2 + p^3r^3) + 18pqr^3 - 27r^4 \\
 & C = 100p^4q^4r^2 - 1242r^6 + 560p^3q^3r^3 - 2150p^2q^2r^4 \\
 & \quad + 2826pqr^5 - 286(p^3p^3q^3r^2 + p^3q^2r^3)
 \end{aligned}$$



$$\begin{aligned}
 & - 34(p^6r^4 + q^6r^2) - 292(q^3r^4 + p^3r^5) \\
 & + p^2q^8 + p^8q^2r^3 \\
 & + 530(p^4q^4r^4 + pq^4r^3) + 50(p^7qr^3 + p^7r) \\
 & - 4(q^9 + p^9r^3) - 12(p^6q^3r^2 + p^3q^6r)
 \end{aligned}$$

in which  $p, q, r$  in terms of the homogeneous variables are

$$\begin{aligned}
 p &= Z_1 + Z_2 + Z_3, & q &= Z_1Z_2 + Z_1Z_3 + Z_2Z_3, \\
 & & r &= Z_1Z_2Z_3.
 \end{aligned}$$

It is to be noted that  $P$  itself is not expressible in terms of  $p, q, r$ , but

$$P = Z_1Z_2Z_3(Z_1 - Z_2)(Z_1 - Z_3)(Z_2 - Z_3).$$

As a remarkable coincidence it was found that the three invariants of the complete form-system of the binary quintic form, when written in terms of a fundamental system of two cross-ratios of the roots, are precisely these forms  $A, P^2, C$ , when similarly expressed in terms of the cross-ratios. It is shown that  $A, P^2$  and  $C$  are the complete form-system of our quadratic group,  $G_{120}$ , by a series of theorems of which the most important are the following: (1) An invariant under a quadratic operator must be a fraction whose numerator and denominator throw off a common factor in the  $Z$ 's. (2) The numerator and denominator of an invariant fraction must be absolute or relative invariants under the linear subgroup and hence rational integral functions of the known invariants in its complete form-system. (3) There can be no invariant fraction whose numerator and denominator are of odd degree or of unequal degree. (4) The most general invariant form suitable for numerator or denominator of an invariant fraction under  $G_{120}$  is of degree  $6n$  and throws off the factor  $r^{2n}$  ( $r = Z_1Z_2Z_3$ ) under the quadratic generator;  $Z_1:Z_2:Z_3 = Z_4Z_3:Z_1Z_3:Z_1Z_2$ . (5) The most general invariant form under  $G_{120}(a)$  is of the form  $P_{6n} = P^{2\mu}R_{6(n-2\mu)}$ , where  $\mu = 0$  or a positive integer and  $R_{6(n-2\mu)}$  contains no factor of  $P$ ; and (6) If  $a$  and  $\beta$  are two

such ternary forms having the binary forms  $a$  and  $b$ , of degree  $\lambda$  and  $\mu$ , respectively, as tangential quantics at one of the critical points, then  $a\beta$  has  $ab$  as its tangential quantic at the same multiple point, and  $a + \beta$  has  $a, b$  or  $a + b$  according as  $\lambda$  is less than, greater than or equal to  $\mu$ . (7) No ternary form can have a binary tangential quantic at any critical point of odd degree in either or both of the cubic invariants belonging to the dihedron subgroup which leaves the critical point fixed. (8) Two reduced ternary forms of the same degree which have the same tangential quantic at any critical point can differ only in such terms as involve  $P^2$  as a factor.

By means of these theorems it is then shown, by a process of successive reduction, that the most general invariant form under  $G_{120}$  is expressible as a rational integral function of  $A, P^2, C$ , and thus a system of fundamental forms is established in terms of which all invariant fractions under the quadratic group can be expressed. The above forms are absolute invariants. The only relative invariant fractions are those expressible in terms of  $A, P$  and  $C$ , which are invariant except for change of sign.

THE CONFERENCE OF SCIENCE TEACHERS  
IN THE TRANS-MISSISSIPPI EDUCATIONAL  
CONVENTION.

A FEW months ago the undersigned was requested by the program committee to arrange a series of conferences of science teachers in connection with the Trans-Mississippi Educational Convention, to be held in Omaha, June 28th, 29th and 30th. As a result there were held seven conferences, namely, in Chemistry, Physics, Astronomy, Botany, Zoology, Geography and Geology, occupying the afternoon sessions of the 29th and 30th. The following abstracts of the principal papers will give some idea of these meetings. The attendance was not large,

being from thirty-five to forty, which was to be expected, since there were conferences upon twelve other lines of study in other places of meeting in the city at the same time.

Professor C. S. Palmer, of the University of Colorado, spoke on the teaching of chemistry. He limited the scope of his remarks to the high and preparatory schools, and noted that only one-fourth of the time is asked for natural science, the other three-fourths involving mathematics, language, (English and Latin), literature and history. He noted that there are two kinds of chemistry to be considered: one, that suited to the one-year course of the average school; and the other a much more concentrated and specialized sort, suited to the newer standards now coming to recognition. He gave the chief arguments for natural science specialization in the high school, defending it against the accusation of narrowness, and emphasizing its disciplinary value.

In view of this he emphasized the value of the qualitative proof in chemistry, leaving the quantitative proof for the college course in the main.

(His remarks will be found in the fuller form in a forthcoming article in the *School Review*, with special reference to a discussion and defence of specialization in natural science in secondary schools.)

Instructor H. V. Kepner, of the Denver Manual Training High School, led this discussion, emphasizing the contention of Professor Palmer.

In the physics conference a paper on 'Graphical Algebra for High Schools' was presented by Professor F. E. Nipher, of St. Louis. This paper was distributed in printed form. It was really an elementary text giving the author's idea of what should be undertaken in connection with instruction in algebra as now taught

Equations based on simple physical con-

ditions were written, and the physical significance of each equation was pointed out. The equations were each represented graphically by curves, lines or surfaces. The geometrical meaning of making equations simultaneous and determining the values of the 'unknown quantities' by elimination was fully shown. The paper will be published as a text-book by Henry Holt & Co.

In the discussion by President C. L. Mees, of the Rose Polytechnic Institute; Professor H. T. Eddy, of the University of Minnesota, and Professor B. E. Moore, of the University of Nebraska, the importance of graphical methods of representing results in Physics was emphasized, and the high schools were urged to give more attention to training their pupils in graphical conceptions.

Professor H. A. Howe, of the University of Denver, presented a paper on 'Astronomy,' in which he said that instruction in astronomy may well be a part of nature study in the four grammar grades. The moon's phases and motion, the seasonal change of the sun's place in the heavens, the motion of bright planets among the stars, and the appearance and changes of position of a few constellations, may be familiarized by observation.

In the high school elementary descriptive astronomy may best be taught in the fourth year; accurate observation of the diurnal revolution of the heavens, and the learning of several constellations, may well precede any work with the text-book. Observation of the heavens and the development of principles and facts by judicious questions should be strongly pushed; memoriter work should be reduced to the lowest limit consistent with a fair general knowledge of the subject.

Collegiate descriptive astronomy is simply more thorough than high school work, and may involve more mathematics. Collegiate mathematical astronomy is most

interesting and profitable where simple instruments for time-taking and for metric measurements are used by the students; where instruments are not available the simpler problems of spherical astronomy may be studied.

Work in celestial mechanics and original investigations along lines of practical astronomy and astrophysics must be done chiefly in post-graduate courses.

In the conference on botany Professor Macbride, of the University of Iowa, argued that the special function of the schools was to give instruction to the people, primarily along practical lines. Botany is an eminently practical science and should reach the largest possible number of our people. To this end botany teaching should not be relegated to the high school exclusively, but simple phases of the subject should be presented to the children of the schools universally. The later methods of presenting the subject, while no doubt logical, have been in large measure unfortunate and without practical value. They have proceeded upon the notion that without microscope and laboratory botany cannot be taught; and, where introduced, they have too often left pupils without any true conception of botanical science, without any knowledge whatever of the commoner forms of vegetation with which every intelligent person, not to say educated person, ought to be familiar. The older methods were faulty because they were so largely text-book methods, but they had the great advantage of using familiar material, of working from the known to the unknown. While unwilling to discourage research-work anywhere, yet, it was argued, such work belongs rather to the universities. In short, public schools of all grades should understand well their mission, which is popular rather than technical education.

Professor J. H. Powers, of Doane College, and Professor C. E. Bessey, of the Univer-

sity of Nebraska, thought that the difficulties in regard to the equipment and management of laboratories in the high schools were not as great as Professor Macbride appeared to believe, and urged the laboratory method as more helpful in high school work.

In the conference in zoology Professor H. B. Ward, of the University of Nebraska, said that since the time of Agassiz no one can question the educational value of zoology nor its consequent right to a place in the high school curriculum. As a natural development of the nature study in the lower grades, it may well come early in the course, preceded at most by a year of general science and physiography, and closely connected with work in botany.

At least half of the time should be devoted to laboratory work, where the observations made by the student independently should be recorded in careful notes and accurate drawings.

To bring the pupils in touch with nature, field excursions should form an integral part of every course. They also yield a desirable collection of objects representing the life of the vicinity and form the nucleus of a school museum which has no reason for existence other than as a working collection.

Constant use should thus be made of the three laboratories: The school room, the museum and the great laboratory of nature. Finally, students should be encouraged to read the travels of great naturalists and thus, through the eyes of Wallace, Darwin, or Agassiz come in contact with the great world of living things.

Professor J. H. Powers, of Doane College, in discussing the paper, spoke earnestly in favor of zoological training, emphasizing the value of laboratory and field work. Professor H. W. Norris, of Iowa College, in continuation insisted that the end sought in zoological instruction is not so much an acquaintance with interesting and profitable



facts as such, but rather the cultivation of an ability to discriminate between the essential and non-essential, and to appreciate the fundamental relationships existing between the various groups in the animal kingdom.

Professor Erasmus Haworth, of the University of Kansas, in the geographical conference dwelt upon the present unscientific treatment of geography in the schools, and discussed at some length the need of a reform in both method and subject-matter. Much of what is given under the name of geography is not geography at all, although it may well be admitted that this non-geographical matter is often quite interesting and in some cases possibly useful. Often, however, there is a large amount of gross and inexcusable error, along with much irrelevant and unimportant matter to be found in the text-books.

A lively discussion followed, in which the current text-books on geography were described as being nearly all bad.

In the conference in geology Professor Todd, of the University of South Dakota, read a paper on 'Geology as a Factor in Education.' He enumerated the various advantages for culture which the study presents. It is equal to any other natural science in its cultivation of the power of observation, while no other has its material so universally accessible and so permanently available. Other sciences often required the use of costly instruments and collections. It cultivates reasoning, especially inductive reasoning, and gives practice in the 'scientific method.' Because its problems deal with all degrees of accuracy and probability it especially fits one for the problems of actual life. No other science can equal it in its cultivation of the imagination and in teaching its legitimate bounds. Because of its tangible data and the importance of its conclusions to related subjects of wide interest, it more than others

cultivates skill in clear and accurate description. It strengthens the moral nature by instilling love for truth, by revealing the marks of an intelligent purpose in the cosmos and by teaching man's humble position, yet great power if he learns to work with Nature. It discovers a healthful and rational recreation. It brings one in touch with many of the great economic problems of society. He concluded that its clearer and simpler principles, which have been grouped under Physiography, should be required in the high school, as was approved by the 'Committee of Ten,' and that more might be offered at that stage as an elective. He presented reasons for deferring the more thorough pursuit of the science until after fair acquaintance with chemistry, physics, botany and zoology, and then at least a year of geology (including mineralogy) should be required of all candidates for the degrees of B.Sc., C.E. and M. E., while it should be accessible as an elective to all.

Professor E. H. Barbour, of the University of Nebraska, and Professor Erasmus Haworth, of the University of Kansas, followed in a discussion which emphasized the culture value of geology in the public schools, no other culture excelling it in the cultivation of the power of close observation.

CHARLES E. BESSEY,  
*Chairman of Science Conferences.*

---

#### CURRENT NOTES ON ANTHROPOLOGY.

##### THE BEGINNINGS OF MIND.

A PLEASANT address on this subject by Dr. Julius Donath, of Budapest, is worth mentioning. It presents in an easy style the accepted principles of modern psychology, and in their light traces the growth of mind in relation to cerebral action in the development of the infant and child and in the species, as exhibited in the contrasts between savage and civilized modes of



thought. The scheme is comprehensive and well carried out in a brief compass.

Dr. Donath notes several of the prevalent errors in such investigations, as lack of discrimination between a given stage of culture and the psychic faculties of those who exhibit it, the mistake of assuming that mental power is correlated to cranial capacity, and especially the incorrectness of supposing a parallelism between the psychical evolution of a child and the race, as Bucke, Baldwin and others have too literally assumed. ('Die Anfänge des Menschlichen Geistes,' pp. 47; F. Encke, Stuttgart, 1898.)

#### MUSHROOM-SHAPED IMAGES.

THEOBERT MALER and others have published illustrations of stone pillars with mushroom-shaped summits, occurring in Yucatan, Guatemala and elsewhere in Mayan territory.

In the *Globus* for May 28th Dr. Carl Sapper gives a picture of one in excellent preservation, about 30 centimeters in height, from San Salvador. On the shaft the face of a man (or monkey) is roughly outlined. Over it is the umbrella-like expansion.

These have generally been considered phallic emblems. Dr. Sapper doubts this, and in fact there is no evidence for it beyond a vague resemblance. He advances, however, no other explanation.

I would offer a suggestion. They resemble in shape mushrooms or toadstools, and why should not that be their intention? Why should it be? Because the word for mushroom in Maya (Tzental dialect) is *hu*, sufficiently near to the word for moon, *uh* or *yuh*, to recall it in sound, and the night growth of the fungus would strengthen the mythical alliance. They would thus be emblematic of the lunar and nocturnal divinity.

#### AMERICAN INDIAN GAMES.

THIS subject is treated in an interesting manner from ample material by Mr. Stewart

Culin in the *Bulletin* of the Museum of the University of Pennsylvania, No. 3, Vol. I. He selects for analysis the game of dice or tossed staves, which he finds among sixty-one North American tribes. With much ingenuity he compares their implements and the decorations upon them, reaching the conclusion that they were all derived from some center in northern Mexico or near there; the thread of connection which leads him being the throwing-stick, or *atlall*, of the Mexicans.

This is ingenious, but not wholly convincing. One may ask why the *atlall* might not have drawn its local symbols and trappings from the game, rather than *vice versa*. The symbolism is surely more recent than the game; *atlalls* are found elsewhere without it; and there are simpler explanations of the elementary symbolism of the game in the northern tribes. In the study of development it is usually wiser to begin with the simple and proceed to the complex, rather than the reverse.

D. G. BRINTON.

UNIVERSITY OF PENNSYLVANIA.

#### SCIENTIFIC NOTES AND NEWS.

##### PREVENTIVE INOCULATION AGAINST PLAGUE.

M. HAFKINE made recently an address on the above subject at Poona, in the course of which, according to the report in the *London Times*, he compared the invasion of India by the plague bacillus to the invasion of Australia by rabbits, to the invasion of certain soils in south Europe by the phylloxera, and to the invasion of South Africa by the organism of the rinderpest, and used these analogies to show that there are, in both the animal and vegetable worlds, diseases of which the cause, the morbid organism, can live and propagate outside the patient's body, can grow in the soil, in water, be carried by clothing, bedding, instruments, by any living or dead object. If it happens that the natural conditions of a country are favorable to the life and propagation of such an infectious organism, and as long

as these conditions continue unchanged, and we are unable artificially to alter them, there is no instance known of such morbid organisms having been 'stamped out,' as the expression in our daily reports is, by the will of men. If it were otherwise there would be no typhoid fever in the European barracks in India; or the microbe of cholera, let us say, would have been 'exterminated' from the plains of Bengal, or the microbe of malaria from the rest of the country. Every time, therefore, said Dr. Haffkine, that you may think of these matters, recall to your memory that rabbit question of Australia, or the phylloxera problem in the vine-growing countries of Europe. I hope you will then cease to wonder at the fact that, when the government and municipalities appoint committees to deal with and to 'stamp out' the plague, the disease does not seem always to obey their measures.

There are, it must be admitted, many phenomena in nature which it is not in our power to arrest; but we can run away from them, or protect ourselves against them individually. The marvellous success of vaccination against smallpox, and the history of the bacteriological efforts of the last 15 years, made the plan for effecting such a protection against plague obvious; and, early after the outbreak of plague in Bombay, I put myself to the task of working out a preventative inoculation to check the liability of individuals to that awful disease.

The first demonstration of the working of this system can be made in the laboratory, and this has been already repeated and confirmed by many observers. You are aware that rats are exceedingly susceptible to plague. One takes 20 rats from a ship that has newly arrived in harbor, say from Europe, where there is no plague. Ten of them are inoculated with the prophylactic against plague, and the others are left as they are. Put back all the 20 rats together, and introduce among them a rat that has the plague, or infect them all artificially with virulent plague microbes. In the course of time you will find that eight or nine, or the whole of the unprotected, will die of the disease; while perhaps only a single rat that has been inoculated with the protective lymph, or even not a single one, will contract the disease.

During the month of January, 1897, a large number of leading European and native gentlemen offered themselves to be inoculated, to prove the harmlessness of this method, and by the end of that month this question was solved, I believe, to the satisfaction of every one who took the trouble of attentively examining it.

The results of the inoculations, up to the end of 1897, were given in some detail from several different localities. The general facts were that the inoculated and uninoculated persons were everywhere living under the same conditions and exposed to the same risks of infection, and that not only were the occurring cases relatively much fewer among the inoculated, but they were also much milder and attended by a much smaller proportionate mortality. To take totals, there were 1,268 deaths among 7,803 uninoculated persons, and, in the same towns or districts, 62 deaths among 11,968 inoculated persons. In Lower Damann the number of cases was not stated, either for the inoculated or the uninoculated; but the deaths were 36 in 2,197 of the former, against 1,482 in 6,033 of the latter. This population being omitted, 259 cases among uninoculated persons were productive of 186 deaths, and 73 cases among the inoculated were productive of 26 deaths. It must be borne in mind, in considering the figures, that a large proportion of the cases occurring among the inoculated became declared within 24 hours of the inoculation, and were evidently the consequences of infection previously received into the system.

#### AN EXHIBIT OF THE HISTORY OF MEDICINE.

As we have already noticed, the Seventeenth Congress of German Men of Science and Physicians will be held at Düsseldorf from September 19th to 24th. In connection with the Congress there will be several exhibits, one of scientific apparatus, one of scientific photography and one illustrating the history of medicine and science. The *British Medical Journal* gives some account of what is aimed at in the last mentioned exhibit. It will comprise two main divisions: (a) general history of medicine, (b) special exhibits. The former class includes: (1) Ancient Phœnician and Egyptian medicine; (2) Assyrio-Babylonian, Medo-Persian and Old

Indian medicine; (3) Lydio-Trojan medical antiquities; (4) Greek and 'Hellenistic' medicine; (5) Ibero-Etruscan and classical Roman medicine; (6) late Roman medicine, with its Gallo-Roman offshoots in Rhineland and in Gaul; (7) Byzantine medicine; (8) Arabian medicine; (9) Chinese and Japanese medicine; (10) Frankish, Saxon and its Gothic medical antiquities; (11) mediæval medicine of other Western countries; (12) the medicine of the Renaissance and modern times up to the end of last century. The medicine of Semitic and other nations will also be represented as far as possible, and an appeal is made to antiquarians and collectors throughout the world to assist in making the exhibition as completely representative as possible. The special class of exhibits will comprise material illustrating the following subjects: (1) Popular medicine, including that of savage peoples and that of civilized peoples. (2) Instruments of all kinds. (3) Geographical exhibits. (4) History of orders and associations for the care of the sick; knights, religious orders, associations of deacons and deaconesses and lay societies. (5) Plague medals, plague masks and amulets against sickness. (6) Illustrations of hospitals, baths, physicians in the sick chamber, operations, dressers, dissections. (7) Medals and portraits. (8) Poetical scientists and scientific poets in Germany from the oldest times to the present day, with special reference to Goethe and his relations to Düsseldorf and the Rhine country. (9) History of medicine and the Lower Rhine, in the Duchies of Jülich, Cleve and Berg, subdivided into exhibitions relating to (a) Laurentius Friesius, (b) Paracelsus, (c) Weyer, (d) Kortum. Here, again, an appeal is made for portraits, medallions, photographs and illustrated works, among the latter, especially such as are of older date than 1580 (receipt books, books about animals, anatomy, distillation, alchemy, astrology, magic, etc.). The exhibitors are not put to any expense, the Exhibition Committee undertaking to pay all freights and the cost of fire assurance. The exhibition, which is to be located in the Kunstgewerbe Museum, will be open in July, and exhibits will be received up to September 15th. The exhibition closes on September 30th. Any further information that may be desired

can be obtained by application to Dr. Frauberger, President of the Exhibition Committee, Kunstgewerbe Museum, Friedrichsplatz, Düsseldorf.

## GENERAL.

THE Paris Academy of Sciences has elected as correspondent in the section of medicine and surgery, Professor Ernst von Leyden, of Berlin. Thirty two votes were cast for Professor von Leyden and five for Professor Zambaco, of Constantinople.

ON the occasion of his 80th birthday Professor Bartholomew Price, Master of Pembroke College, Oxford, has been given a dinner at Queen's College by his former pupils. He intends to resign the Sedleian chair of natural philosophy which he has held for forty-five years.

DR. ALLAN P. SMITH, a distinguished Baltimore surgeon, one of the original trustees of the Johns Hopkins University, died at Baltimore on July 18th. A. H. B. Beals, professor of philosophy and education in the University of Washington, was killed by falling through an open hatch on the steamship 'Arizona' on July 18th.

C. L. SHEAR and Ernst A. Bessey, recently of the department of botany of the University of Nebraska, and now of the United States Department of Agriculture, have been sent to northern Colorado by the Division of Agrostology to collect grasses and seeds and to secure information in regard to the native and introduced forage plants of that region.

DR. L. A. BAUER is engaged this summer in locating and marking the boundary line between Allegheny and Garrett counties, Maryland. This boundary line calls for a straight line connecting two non-intervisible points, 20 miles distant from one another, the one being on the Great Savage Mountain, along the Mason and Dixon line, and the other at the mouth of the Savage River. Upon the completion of this work he will resume the magnetic survey of Maryland.

PROFESSORS H. D. CAMPBELL and D. C. Humphries, of Washington and Lee University, are engaged in the work of the U. S. Geological Survey during the present summer.



Professor Humphries is making measurements of the rivers of southwestern Virginia.

It is hoped that ground will be broken shortly for the main or central portion of the Peabody Museum, Yale University, in order that the building may be completed at the time of the bi-centennial celebration in 1901. The reserve building fund left by Dr. Peabody now amounts to \$100,000, and efforts are being made to collect the remaining \$150,000 needed.

THE Dreadnought Seaman's Hospital at Greenwich has organized a school for the study of tropical diseases. The Colonial Office has contributed £3,550 towards the buildings, which it is estimated will cost about £13,000. Provision will be made for from 20 to 25 students, and there will be a fully equipped laboratory, pathological room and museum.

THE sum of £10,000 has been subscribed towards the Jenner Memorial. Half of this sum has been given by Lord Iveagh.

At a meeting of the standing committee of the Trustees of the British Museum on July 9th a letter was sent to Sir William Flower expressing profound regret in accepting his resignation of the directorship of the Natural History Museum and expressing high appreciation of his services during the past 14 years. The letter continues: "The rare combination of wide scientific knowledge with marked administrative ability and a sympathetic appreciation of the requirements of the uninstructed public has carried you through a most difficult task. Under your hands the natural history collections of the British Museum have fallen into the lines of an orderly and instructive arrangement which no one, whether man of science or ordinary visitor, can examine without admiration. To you, as a worthy successor of Sir Richard Owen, will attach the honor of having organized a museum of natural history which now occupies a preëminent position among all the museums of the civilized world."

A MEMORIAL has been addressed to the Trustees of the British Museum by a number of leading British men of science, protesting against the rumored abolition of the post of Director of the Natural History Museum, resigned by Sir

William Flower. Both Sir Edward Maunde Thompson, the Director and principal librarian of the British Museum, and Sir William Flower have written stating that the memorial was founded on a misapprehension. The Natural History Museum has always been a part of the British Museum, of which Sir Edward Maunde Thompson has been the chief executive officer, and the Trustees have no intention of abolishing the office of Director of the Department of Natural History, or of imposing any new limitations on the duties of that office.

THE Congress of the Royal Institute of Public Health will meet in Dublin next month. The meetings will be held in Trinity College, where Sir Charles Cameron will deliver the presidential address on the opening day.

It may be remembered that there was held an International Congress of Experimental and Therapeutic Hypnotism in Paris in 1889. A second Congress has been arranged to follow the close of the International Medical Congress in the month of August, 1900. Four sections are planned: (1) The clinical and therapeutic relations of hypnotism and suggestion; (2) their medico-legal relations; (3) their psychophysical relations, and (4) their applications in pedagogy and sociology. Further information may be obtained from the Secretary, Dr. Bérillon, 14 rue Taitbout, Paris.

BEFORE the Zoological Society of London, on June 21st, Mr. Abbott H. Thayer, of New York, explained his method of demonstrating, by actual experiments, the underlying principle of protective coloration in animals. An exhibition of his demonstrations was given in the Society's Gardens next day.

THE report of Professor Lawrence Bruner, of the University of Nebraska, special agent for the investigation of the locusts of the Argentine Republic in 1897-98, has just appeared. It includes figures and descriptions of the species which have been found to be most harmful, together with discussions of preventive and remedial measures.

SIR ARCHIBALD GEIKIE is preparing for the press a portion of the third unpublished volume of Hutton's 'Theory of the Earth,' consisting



of six chapters which have been in the possession of the Geological Society since 1856. The rest of the manuscript cannot be found, but these chapters contain many interesting observations.

THE Ninth Report of the Missouri Botanical Garden contains several short papers by Professor Trelease. One on Florida *Epidendrum* shows that the plant of the Florida flora which has long been known as *Epidendrum venosum* is in reality *E. Tampense*, a species quite different from the true Mexican *venosum*. A colored plate of *Tampense* and a half-tone from a photograph of *venosum* render the distinctions quite evident. A second paper on the common species of *Apocynum* calls attention to the characteristic difference in the habit of growth and position of the leaves of the common Dogbanes, *Apocynum androsaemifolium* and *A. cannabinum*, which is well shown in two half-tones. A 'new palm fungus' is a short note concerning a palm disease which has proved quite destructive in Nebraska, and which is described as new, under the name *Exosporium palmivorum*. In a fourth paper Professor Trelease describes and figures a magnificent specimen of *Yucca gigantea*, which he found in cultivation in one of the gardens of the Azores, some years since, and also notes certain changes in nomenclature of *Yuccas*, bearing upon his earlier studies of these interesting plants. A proliferous inflorescence of *Y. constricta* collected in New Mexico, by Miss Mulford, is also described and illustrated by a half-tone engraving.

At a special meeting of the Royal Geographical Society, London, on June 27th, Professor Elisée Reclus brought forward his scheme for the construction and erection of a great terrestrial globe. According to the report in the London *Times* he began with a reference to the paramount importance which perfect accuracy had assumed in the knowledge of our planet; he pointed out that truthful representation of a fragment of a sphere was impossible on a plane surface. There was only one way of representing truly the surface of the earth; a sphere or fragment of a sphere must be reproduced by another sphere or fragment of a sphere. That was why he had such an intense desire to

see scientific opinion give this mode of planetary representation much greater attention than heretofore. Spherography, although the most important department of geography, had not kept pace with cartography, in which immense progress had been made, and he presumed it would be a real revolution when it had taken in science and practice the paramount place it deserved. Even scientific people were not yet sufficiently convinced of the absolute necessity of studying geography on images of our planet reduced to a given scale with the real proportions. If the scale of the globe were very small—one to ten or twenty millions, for example—the surface had to be kept exactly even, polished, so to say, because the proportional size of highlands and mountains could not be represented. In larger spheres another element of truth and beauty was added in that the actual relief appeared on the curvature of the model. The system of exaggerating altitudes was utterly bad, contrary to real science, and to be discouraged by all geographers having respect for Nature and her laws. But as soon as the sphere was large enough to show at least one-millionth part of the real proportions then the heights and depths as well as the planimetric dimensions should be represented on that scale. On a large globe on the scale of 1:100,000, rugosities of the surface might be finely shown, even hillocks 50 meters in height. Such representation of ordinary heights would afford an unexpected advantage by furnishing a standard of comparison, since those looking at a relief would easily estimate the real dimensions of a country by the sight of the ridges and mountains that diversified the surface. In conclusion Professor Reclus said the moment had come for a grander representation of the earth than had hitherto been made, for the erection of a model globe which would be as scientifically accurate as possible and which, being kept continually under correction, would become not only a thing most beautiful to look at, but also a standard study for travellers and geographers.

AN explosion of acetylene gas occurred on July 9th at the metal works of Messrs. Goliash & Co., Berlin. A foreman was killed and another man was slightly injured.

THE report of the Joint Select Committee of the British House of Lords and House of Commons on electrical energy (generating stations and supply) has been published in a Blue Book.

A COMMISSION has been appointed to revise the United States patent laws.

As we have already stated, the Albert Medal of the Society of Arts has this year been awarded to Professor Bunsen. At the annual meeting of the Society held recently, says *Nature*, the work of Professor Bunsen was referred to by the Council in the following words :

“ Amongst the numerous and important scientific discoveries which have rendered the name of Bunsen famous wherever science is valued, perhaps the most striking is the one in which he was associated with his distinguished colleague, Professor Kirchoff, viz., spectrum analysis, a discovery which has shed a new and unexpected light on the composition of terrestrial matter, and has enabled us to obtain a distinct knowledge of the chemical composition of sun and stars. The contributions which Bunsen has made in the application of chemistry and physics to the arts and manufactures are of the utmost value, and their importance may be measured by two out of many instances. The Bunsen battery was, until the introduction of the dynamo, the cheapest source of electricity ; the Bunsen gas-burner, by which a non-luminous, smokeless, but highly heated flame is obtained, is now not only indispensable in all laboratory work, but is used for heating purposes in thousands of houses and manufactories, and for illumination, by the incandescent system, in millions of lamps. Beyond these Bunsen's contributions to the sciences of chemistry and physics have been of the highest importance ; but, perhaps, the greatest benefit which he has conferred, through a long life devoted to the advancement of science, has been the influence which he has exerted as a teacher.

stroyed by fire last March. In addition to this gift instruments and machinery to the value of \$30,000 have been given to furnish the building.

MR. JOHN D. ROCKEFELLER has subscribed \$10,000 toward the special fund now being collected for Barnard College.

CARROLL COLLEGE, of Waukesha, Wis., has received from Mr. and Mrs. Ralph Voorhees, of New Jersey, a gift of \$50,000 on condition that \$50,000 more be subscribed by October 1st. \$6,000 towards the latter sum has already been subscribed.

THE University of Paris has instituted a degree of ‘ Doctor ’ without any qualifying word. The new degree is open to foreigners and the tests are a thesis in French or Latin and a few questions on subjects selected by the candidates.

#### DISCUSSION AND CORRESPONDENCE.

##### MIOCENE EDENTATES.

IN the *American Naturalist* for December, 1886 (p. 1044), Professor Cope described a number of osseous scuta and toe bones as those of a ‘ giant armadillo from the Miocene of Kansas,’ under the name *Caryoderma snovianum*. The type specimen is now in the University of Kansas Museum. The scuta and toe bones are identical in all respects with another series recently removed from the carapace of a large tortoise from the same formation in Kansas, the Loup Fork. The tortoise is provisionally placed in the genus *Xerobates*, and is specifically probably identical with *Testudo undata* Cope. The error was not an extraordinary one on the part of Cope, since the dermal ossicles are peculiar for a tortoise. Its rectification, however, is important, since this reference was, I believe, the only one of the edentates to the Miocene of North America.

S. W. WILLISTON.

UNIVERSITY OF KANSAS, July 16, 1898.

#### UNIVERSITY AND EDUCATIONAL NEWS.

IT was stated in a recent issue of SCIENCE that Mr. George A. Fowler had rebuilt the engineering building of the University of Kansas, which was struck by lightning and de-

#### SCIENTIFIC LITERATURE.

*La fatigue intellectuelle.* Par A. BINET et V. HENRI. Paris, Schleicher Frères. 1898. Pp. 336. (Bibliothèque de Pédagogie et de Psychologie.)

It would be difficult to select a topic in the field of psychology that would enlist a wider interest than that of mental fatigue. It is one of the most characteristic of the ills that flesh, or at all events civilized flesh, is heir to. From the school boy to the professor, in all professions and in business, the cry is overwork, exhaustion and fatigue. The well known tired feeling is altogether too familiar, particularly in newer civilizations and in communities in which the push and drive of commercial ambition set the pace for an equally exhausting social and intellectual competition. As a question of practical hygiene the avoidance of undue fatigue is of the highest importance; and here, as elsewhere, the only certain path to relief is the one that leads through a systematic study of the nature of the normal and abnormal processes concerned. The physiology and psychology of fatigue must be minutely and successfully investigated before the practical applications can be made to the routine of the school room or the most economical division of labor for the intellectual worker. In a matter of such fundamental and familiar import there is, of course, a considerable accumulation of wisdom, which, however vague or ill arranged, must not be altogether despised. It is, unfortunately, true that in many emergencies of life our actions cannot be guided, even if we are ready to guide them, by scientifically established principles and logically verified inductions. Particularly in such complex matters as psychology must take into account is there the greatest necessity for discernment and caution in applying knowledge to practice. Individual differences and circumstantial details often profoundly affect deductions; for it is equally true that one man's meat is another man's poison, and that one man's work is another man's play. These considerations are presented to imply not that the management of intellectual effort and the avoidance of fatigue cannot be directed by scientific principles, but rather by mother wit, but only that the illumination of this field of inquiry is a difficult and slow process. None the less we can dispel the total darkness that hangs over the region and here and there get up a modest searchlight that may reveal the more intimate nature of a few limited areas.

The work of Messrs. Binet and Henri, though not the first work on fatigue, is the first work on mental fatigue, and the first attempt to prepare a compendium of our knowledge regarding the general topic. If the net outcome seems meagre the above considerations regarding the difficulties and newness of the inquiry may be urged in excuse. It should also be borne in mind that the removal of misconceptions and the elaboration of a method in themselves form a considerable advance.

The investigations regarding mental fatigue naturally fall into two divisions: first, the effect of intellectual effort upon physiological functions; and second, their effect upon psychological activities. The establishment of the general principle that mental processes are correlated with cerebral functions, which in turn depend upon the integrity of a wholesome blood supply, prepares us for the conclusion that all intellectual effort modifies, however slightly, the physiological status of the moment. The ingenious demonstrations of Mosso and others have revealed the marvellous delicacy of this psycho-physical interdependence, that seems to be limited only by the sensitiveness of our devices for detecting it. More directly, Hodge has shown the effects of more or less prolonged fatigue upon nerve cells, so that our conception of a tired nerve cell is no longer purely a matter of hypothesis. There is, of course, no definite point at which work passes into fatigue; the effects of fatigue are the effects of continued activity, the intensity and even the kind of effects depending upon the prolongation of the effort. There are also the accompanying subjective feelings of fatigue, but these have not been made part of experimental investigations.

The first group of problems in such investigation relates to the selection of typical forms of mental effort and the technique by which their effect upon physiological functions may best be noted. Counting the number of letters in a printed passage, writing to dictation at a maximum speed, reading aloud, numerical calculations performed mentally, committing numbers or syllables to memory, have all been employed. The main desiderata for the most



suitable experimental mental effort is one that shall involve a minimum of motor expression; that shall, too, as nearly as possible, involve the same processes when performed by different persons; that shall involve continuous but not too severe concentration, and that shall yield results by which the duration and the correctness of the task performed can be measured. No one of the above processes answers all of the requirements—and they are not the only ones—but on the whole the authors prefer the dictation and regard simple calculations as highly appropriate. One further general fact must be taken into account. In repeatedly performing the same mental task we become more proficient and do it more rapidly and better. Fatigue would tend to lengthen mental processes and introduce error. Hence the effect of practice tends to counteract and disguise the effects of fatigue; still it would remain true that the most fatiguing type of effort would show a less rapid increase of efficiency with practice than lighter occupations. Neglecting for the moment these and other difficulties, we may briefly review the established results regarding the effect of certain typical forms of intellectual effort upon physiological and psychological functions.

It appears that intellectual effort at first quickens the heart beat, but later (after 30 minutes or more) slackens it; at the same time the pressure of the blood is increased; more blood flows to the brain, and the character of the pulse curve is affected. Likewise the respiration is quickened, but the amplitude of each inhalation is diminished and the amount of carbonic acid given off and of oxygen absorbed is increased, while for any considerable mental effort the bodily temperature becomes higher. It likewise appears that the effects of prolonged effort are frequently of an opposite character to those of a brief, even if violent, effort, and that individual differences are significant. Moreover, most of these results are quantitative in character, and by far the largest portion of the first part of the volume (in itself over 200 pages) is devoted to a technical account of the equipment by which such quantitative results may be secured.

A particularly important relation is that be-

tween intellectual effort and muscular effort. A brief mental exertion (15 minutes or less) seems to increase the momentarily available muscular energy as measured by the dynamometer, but a longer mental exertion distinctly decreases it, and particularly does it decrease the total capacity of muscular work as measured by the Ergograph. Emotional excitement in connection with intellectual work may postpone the muscular enfeeblement and continue for a longer period the increase of muscular energy which appears to accompany brief mental exertions. Furthermore, the effect of longer and shorter periods of rest may be measured by their restoration of the total working energy as compared with the normal. In some of Mosso's subjects this tendency of mental work to deplete the muscular energy is most striking; and the Ergographic curves written by a professor on three successive days of holding oral examinations of candidates for a degree reveal a progressive muscular exhaustion, which in turn gives place to a gradual recuperation after one or more days of rest. Evidence of this character leads Professor Mosso to hold that physical exercise is not a proper relaxation from mental effort; absolute rest of mind and body is more desirable and effective. In this connection, as well as elsewhere, it is important to emphasize the difficulty of establishing a normal by which deviations caused by mental exertion or other influences may be measured; for there are larger and smaller fluctuations of all kinds. The morning and the evening, before and after meals, or sleep, the summer and winter, age, sex and temperament, all introduce complications which can only be eliminated by prolonged and logically conducted observations.

Before proceeding to the more strictly psychological studies attention may be drawn to two interesting fatigue curves, which the authors have found in their observations. The first relates to the consumption of bread in certain French boarding schools for the different months of the year, it being understood that bread is supplied *ad libitum*. It appears that in the months following the vacations most bread is consumed, the amount decreasing with fair regularity until the minimum is reached in



July; and this is interpreted to mean that there is a gradual decrease in vitality as the result of the continued school work. The second is the remarkably close correlation between changes in touch sensitiveness as tested by the aesthesiometer and the fatigue effects of mental occupation. After an hour or two spent in the class room the distance apart between two points which can still be felt as two when applied to the forehead, or the nose, distinctly increases, and after a rest it again decreases. This is probably to be interpreted as a modification not in skin sensibility, but in the attention, for it requires close attention directed to the part touched to distinguish whether one feels a single point or a pair of points. None the less it is somewhat noteworthy that this test should yield more positive and uniform results than several others in which the mental element is apparently more prominent.

In the psychological tests the pervading principle is the detection of changes in the rapidity, accuracy, scope and extent of mental processes due to a general intellectual fatigue or to the special waning of the particular group of processes as the result of their prolonged exercise. A good example of the latter class is the test frequently applied to school children of requiring them to perform an extended series of simple additions or multiplications. In a typical result there is first an increase in facility due to the practice or adaptation to the task, which gives place to a decrease in facility from quarter-hour to quarter-hour; and the increase in the number of errors furnishes a still more striking evidence that fatigue is setting in. Here, again, a period of rest will bring about a return to a normal facility, and a rest of two hours will be more effective than a rest of one hour. A good example of general fatigue is evidenced in the comparison of the rate and accuracy of addition or dictation or memory or reaction-times in the early morning hours and again at the close of the morning or the day's work. In a typical curve, in which time or errors are tabulated, the time needed for the calculations, as well as the proportion of mistakes, increase after school work, decreasing again after hours given to recreation. There is quite definite evidence as well that a more

concentrated effort brings about a greater increase in time and errors, and that the various forms of test for mental fatigue—calculations, dictations, reactions, memorizing and the like—yield consistent although not equally definite results.

It thus appears that an appreciable advance has been made in the methods of detecting the nature and degree of fatigue of various types; that interesting and fairly precise means of measuring these have been devised; some insight into the variety and complexity of the factors involved in fatigue has been gained, and some moderately successful applications to the work of the school room have been offered. To pursue the investigations further requires a further elaboration of technique, a more complete elimination of the sources of error, a more thorough application of logical method to the arrangement and interpretation of tests. One very wholesome lesson of all this is that the path from knowledge to practice is a long and tortuous one. A suggestion arising from a slight experimental investigation is not a sufficient basis for raising a cry of overwork, or for reforming the school program; nor is an off-hand acquaintance with the general results of studies in fatigue without a detailed comprehension of the experimental conditions under which such results were obtained, a proper basis for either their criticism or their application to pedagogical problems. The study of mental fatigue is certain to become, and practically has become, a technical acquisition; the popular interest must be severely regulated by scientific method and caution; its possible practical aspect and the desire to reach practical results must not be allowed to interfere with a proper theoretical discussion and analysis. Moreover, the road from theory to practice must be by way of a quantitative analysis. The determination of the facts of fatigue, however useful and indispensable, is in part subservient to the determination of the degree of fatigue; the how much rather than the how is needed for practical application, or rather it is precision of nature and degree that makes practice possible. The fact that many diseases are of germ origin is, of course, of great importance, not only negatively by discouraging

other hypotheses, but positively by shaping men's views regarding disease in a right direction; but the great applications of this view came only when it was demonstrated that certain definitely recognizable microbes were the cause of definitely recognizable diseases. It was the precise, not mere general, knowledge that most largely influenced practice. In the same way regarding fatigue our most valuable applications can be expected to appear only when detailed and precise investigations have reached a high degree of development.

Not all fatigue is dangerous or abnormal, and because children or scholars become tired it does not follow that they are overworked. The lowest functions, notably the heart beat, seem to have an automatic or semi-automatic form of recuperation; so that, provided there is no forcing of them to work at too high a speed, recuperation keeps pace with exhaustion. The highest functions, and, most of all, the brain energies demanded by civilized life, fatigue more readily. At what point normal fatigue passes into abnormal it is not easy to determine. The best test is the capacity for recuperation. A fatigue, however severe, whether physical or mental, that is totally dissipated by a night's rest can hardly be said to be abnormal. It is only when the principal is being drawn upon that the danger of exhaustion begins. Severe effort, periods of strain and stress, are unavoidable in modern life. The capacity to undergo them is a legitimate aim of education, but still more important is the recognition of the danger line and the strength to refrain. A most important phase of intellectual hygiene is that suggested by the dangers of abnormal fatigue. This is only slightly touched upon in the present volume and still awaits a comprehensive as well as practical treatment.

'La fatigue intellectuelle' must be welcomed as a useful and ably prepared compendium; it is by no means a perfect book, possibly not even as good a book as the imperfect material at command made possible. There are some important omissions, such as the neglect of the important work of Lombard and Hodge; the perspective is frequently unfortunate, many pages being allotted to technical discussions which more properly belonged to an appendix,

and the main line of argument consequently suffering in continuity; and considerable material is introduced, such as the long discussion of the report on 'le surmenage intellectuel' of the French Academy of Medicine, which is of a secondary interest and hardly germane to the rest of the work. None the less, the volume is a noteworthy one, which no student of psychology can afford to overlook.

It is further noteworthy as the first volume of a series on pedagogy and psychology. The announcement of such a series indicates that in France the problem of the relation between these two disciplines has been seriously taken up. The authors of the present volume are most forcible in their expression of the view that the pedagogy of the future must be founded upon psychology, and that most of the old pedagogy is 'verbiage.' The further progress of this movement in France will be watched with the greatest interest by those in America who are laboring with the same problem.

JOSEPH JASTROW.

*Syllabus der Pflanzenfamilien. Eine Uebersicht über das gesammte Pflanzensystem mit Berücksichtigung der Medicinal- und Nutzpflanzen. Zweite, umgearbeitete Ausgabe. Von DR. ADOLPH ENGLER. Berlin, Gebrüder Borntraeger. 1898. 8vo. Pp. 214.*

The near completion of *Die natürlichen Pflanzenfamilien* originated by Engler and Prantl some ten years ago gives this *Syllabus* a peculiar interest, as it attempts to place in compact form the conclusions of the senior and only surviving author of the *Pflanzenfamilien* with reference to the relationships of the various groups of plants. We can but feel that if the cryptogamic projector had lived, the *Uebersicht* would have been less one-sided, for on its cryptogamic side it shows patch-work instead of a logical summary made from a broad perception of relations and perspective. We shall criticize the work mainly from the cryptogamic side, but, as it represents the highest generalization of the so-called Berlin school of botanists, it must also be criticized in those points in which it departs from their announced principles of taxonomy. For the arrangement of the spermatophytes it represents, without doubt, the work

of the highest authority, based as it is on the earlier work of Eichler, for in the past few years the Germans have surpassed the English in their broad philosophical views of taxonomy and are leaving all other European nations far in the rear in their advance in systematic botany. The work is further useful to students in that it calls attention in a brief but pointed manner to those plants which are useful to man, and this with its systematic arrangement makes the syllabus a practical and convenient handbook. In the systematic arrangement the following succession of groups is adopted :

ABTHEILUNG,  
 UNTERABTHEILUNG,  
 KLASSE,  
 UNTERKLASSE,  
 REIHE,  
 UNTERREIHE,  
 FAMILIE,

A series practically the same as that generally followed on this side of the Atlantic since *Abtheilung* is the equivalent of *Phylum*, and *Reihe* of our *Order*.

The chief divisions of plants as far as classes given in the *Syllabus* are as follows :

I. Abtheilung. **Myxothallophyta.**

1. Klasse. ACRASIEAE.
2. Klasse. PLASMIDIOPHORALES.
3. Klasse. MYXOGASTERES.

II. Abtheilung. **Enthallophyta.**

1. Unterabtheilung. *Schizophyta.*
  1. Klasse. SCHIZOMYCETES.
  2. Klasse. SCHIZOPHYCEÆ.
2. Unterabtheilung. *Flagellatae.*
  1. Klasse. ACHROMATOFLAGELLATE.
  2. Klasse. CHLOROFAGELLATE.
  3. Klasse. PHÆOFLAGELLATE.
3. Unterabtheilung. *Euphyceæ.*
  1. Klasse. PERIDINIALES.
  2. Klasse. BACILLARIALES.
  3. Klasse. CONJUGATE.
  4. Klasse. CHLOROPHYCEÆ.
  5. Klasse. CHARALES.
  6. Klasse. PHÆOPHYCEÆ.
  7. Klasse. DICTYOTALES.
  8. Klasse. RHODOPHYCEÆ.
4. Unterabtheilungen. *Eumycetes.*
  1. Klasse. PHYCOMYCETES.
  2. Klasse. BASIDIOMYCETES.

3. Klasse. ASCOMYCETES.  
 Anhang FUNGI IMPERFECTI [sic].  
 Nebenklasse LICHENES.
4. Klasse. LABOULBENIOMYCETES.

III. Abtheilung. **Embryophyta zoidiogama.**

1. Unterabtheilung. *Bryophyta.*
  1. Klasse. HEPATICÆ.
  2. Klasse. MUSCI.
2. Unterabtheilung. *Pteridophyta.*
  1. Klasse. FILICALES.
  2. Klasse. SPHENOPHYLLALES.
  3. Klasse. EQUISETALES.
  4. Klasse. LYCOPODIALES.

IV. Abtheilung. **Embryophyta Siphonogama.**

1. Unterabtheilung. *Gymnospermae.*
  1. Klasse. CYCADALES.
  2. Klasse. BENNETTITALES.
  3. Klasse. CORDAITALES.
  4. Klasse. GINKGOALES.
  5. Klasse. CONIFERÆ.
  6. Klasse. GNETALES.
2. Unterabtheilung. *Angiospermae.*
  1. Klasse. MONOCOTYLEDONÆ.
  2. DICOTYLEDONÆ.

The most patent objection to the primary divisions of the above series is seen in its clumsy group names. With such appropriate names as *Archegoniata* and *Spermatophyta*\* in common use on both continents, the use of such compound terms as 'Embryophyta zoidiogama' and Embryophyta siphonogama' is entirely uncalled-for, especially since the supposed characters involved in the terms have been exploded by the researches of Japanese and American botanists. Likewise the use of prefixes, particularly that of 'Eu' is highly objectionable. If a plant is a thallophyte at all, it is naturally a true or sure-enough thallophyte without the use of a prefix; and if the Mycetozoa are to be retained in the vegetable kingdom where they undoubtedly belong, some group name suggestive of their animal affinities would be at once more suggestive as well as more simple than 'Myxothallophyta.'

Notwithstanding the dictum issued from Berlin in regard to the proper rules of nomenclature to be followed, announcing, among a few other excellent suggestions, that family names

\*Or *Spermatophyta* if exact etymology rather than condensed simplicity is sought.



exclusively should end in *-aceæ* and ordinal names in *-ales*, in this first publication issued under those rules their author violates them in giving the termination *-ales* to fourteen out of thirty-four of his *classes*! But this is not all. In the synopsis before us the same termination, which by the rules should be restricted to *orders*, is given to group names of four different grades, as follows:

*Klassen*: Plasmodiophorales, Peridinales, etc., as above.

*Unterklassen*: Bangiales, Sphagnales, Andreales, Archidiales, Bryales.

'*Familien-gruppe (Unterordnung)*': Uredinaceales, Auriculariaceales, Perisporiaceales, etc.

*Reihen*: Is used in the majority of cases (though for less than 60 per cent. of the cryptogamic orders), but with such unnecessary exceptions as Siphonæ, Phæosporeæ, Zygomycetes, Autobasidiomycetes, Basidiolichenes, Cleistocarpeæ, etc., among the cryptogams, to say nothing of *nine out of the eleven orders of Monocotyledinæ*! Surely consistency is not a marked feature of the Berlin system!

If any of the leading parts of a system are to appear, their appearance should be a constant feature. Surely classes and orders should not be omitted in any well-constructed system; and yet here we find no orders whatever among the schizophyta, the diatoms, the conjugatæ, and the gymnosperms, and among many of the cryptogams, particularly the fungi, the orders appear to have been distributed to the next lower groups of some suggested system, instead of being built up as names for closely allied groups of families bound together by such morphological characters as would indicate a community of descent. Surely such conglomerates as *Autobasidiomycetes* and *Euascales* are not homogeneous, and no one familiar with fungi would think of regarding them as such.

If the Zygomycetes and the Oomycetes are to be regarded as simply orders, why should their homologues in the algal series be placed the one as a class (*Conjugatæ*), and the other simply as an order (*Siphonæ*)? And what reason except inconsistency for not writing the latter name *Siphonales*, uniform with *Protococcales* and *Confervales*, which are consistently formed?

For our own part we cannot see why *Spirogyra* and the desmids deserve class distinctions from *Vaucheria*, when *Hydrodictyon* and *Draparnaldia* do not receive it. Surely an order *Conjugales* among the Chlorophyceæ would be a more logical arrangement and it would seem that *Coleochæte* might be more properly advanced to ordinal rank than *Chara* to that of a distinct class. The elevation of the Laboulbeniaceæ to class rank will be regarded as a bold step. Surely with all their unique characters they are more truly Ascomycetes than the Ustilaginales are Basidiomycetes! An order surely they are, as we have before affirmed, but scarcely a class. And one order, the Myxobacteriales, is not even mentioned, due largely, no doubt, to the fact that they have been worked out by an American investigator, for work done on this side of the Atlantic is systematically overlooked by the Germans in their usual self-complacent manner.

We doubt, too, if bryologists will agree in assigning subclass distinction to the four orders of Musci, especially when *Anthoceros* has only ordinal separation from the other Hepaticæ. Neither will fern students agree with the separation of *Marattia* and *Ophioglossum* as types of orders while the other groups of ferns remain merely families. Better by far regard the Filicales, Lycopodiales and Equisetales as orders and thus avoid the unjust and unequal separation of groups that were never thus organized by nature. A similar criticism again might be given to the classes of Gymnospermæ which, posing as orders, would be at once more simple and more rational.

The German tendency towards redundancy shows itself not only in the *Abteilung* as noted above, but also in the *Reihe* as '*Filicales leptosporangiatæ*,' and '*Lycopodiales eligulatæ*,' and even in the families as '*Jungermanniaceæ anacrogynæ*.' Such complexities of polysyllables as well as such minor redundancies as *Euequisetales* should not be allowed to complicate a proper system.

In several cases, ordinal terminations are badly formed as Uredinaceales for the simpler Uredinales, Auriculariaceales for Auriculariales, Hypocreaceales for Hypocreales, Sphaeriaceales for Sphæriales, etc., all of which were



more properly used in *Die natürlichen Pflanzenfamilien*, but here have become unnecessarily complicated.

*Die natürlichen Pflanzenfamilien* has been exceedingly unfortunate in the preparation of its cryptogamic portions, not only in the loss of its cryptogamic editor, but, before the completion of their work, of a collaborator in each of the series algæ and fungi, who were removed by untimely death. This has made the treatment of these groups very unsatisfactory, particularly the fungi, which are more varied and complicated and hence more difficult in treatment, and their *Uebersicht* in the present work is surely no improvement over the patch-work of the former treatise. While the *Syllabus* can probably be regarded as the expression of the clearest generalizations with reference to the relations of the higher plants, as a systematic arrangement of the cryptogams it is in many of its features unfortunate and in a few a lamentable failure.

—L. M. UNDERWOOD.

*A Text-Book of Special Pathological Anatomy.* By ERNST ZIEGLER. Translated and edited from the eighth German edition by DONALD MACALISTER, M.A., M.D. and HENRY W. CATTELL, M.A., M.D. New York, The Macmillan Company. 1896, '97.

Pathology in its modern sense is one of the youngest of the biological sciences, although its subject-matter ranks with anatomy in antiquity. No more rapid strides have been made by any department of biology than have marked the progress of pathology, and none has suffered greater transformation since the promulgation of the cell doctrine. It is to be remembered that it was a pathologist who formulated the doctrine *omnia cellula e cellula*. At the present time pathology embraces several fields more or less distinct, invading, in its persistent search for the prime causes of disease, the domains of botany, on the one hand, and zoology, on the other.

It seems to us natural to regard bacteriology as essentially a medical subject, although the number of species of bacteria of interest and known to the pathologist is but a fraction of those of which the botanist must take account. However, it is to the constant endeavors of the

physician that the present relatively extensive knowledge of bacterial species and activities is to be ascribed. Without his quest for the cause of the contagious and infectious diseases, bacteriology as a science would scarcely exist to-day. In the same way the lowest animal forms will receive a new interest and meaning, and there will arise a new impetus to their study, so soon as more diseases are traced to them and improved technical means make it possible to control their investigation, as can now be done with the bacteria.

A fair idea of the progress of pathology can be gained by comparing the two English editions of the text-book under consideration, the first—that which appeared in 1884—with the present one. The main difference is not found in the greatly increased volume of the latter, but in the altered points of view and the definiteness of the one as compared with the other. Pathology, like other natural sciences, has been characterized, in its growth, by two stages—one the acquisition of data, and the other the orderly arrangement and classification of the accumulated facts. Workers all over the world are still busy collecting data and verifying, where possible, their observations and conceptions by experimentation under known conditions. The animal organism is exposed to so many influences of injurious nature—some generated within and others applied from without the organism—that there seems no end to the variety and complexity of the phenomena met with. Notwithstanding this fact, the complex problems of inflammation, new tissue formation, the causes of destructive lesions in liver, kidney and brain, are beginning to be understood no less than the diseases, such as tuberculosis, glanders and malaria, which are due to the invasion of microparasites into the body.

A text-book will of necessity be in the rear, never in advance, of a rapidly-growing subject. It fulfills its purpose, if it is a trustworthy record, in a convenient form, of the more important facts, and if it reflects the spirit of progress of the subject. This Ziegler's text-book has continued to do, improving with each successive edition, until now it has become one of the most useful books in any language. The rapidity with which it goes through editions is testi-

mony to the favor in which it is held by students in its own language, and it can be safely predicted that the new English translation will gain a large following among students of medicine in English-speaking countries. The work of the translators can be commended freely and that of the publishers equally.

SIMON FLEXNER.

JOHNS HOPKINS UNIVERSITY.

#### SOCIETIES AND ACADEMIES.

ZOOLOGICAL CLUB, UNIVERSITY OF CHICAGO.  
MEETINGS OF THE SPRING QUARTER, 1898.

THE METAMERISM OF *HIRUDO MEDICINALIS*.

RESULTS were obtained by the use of gold chloride and methylen blue.

The typical somite consists of the double nerve cord, Faivre's nerve, Leydig's cells, six ganglionic sacs, and two pairs of nerves, the anterior of which carries accessory ganglia. The anterior nerve is the principal sensory one, innervating all the ventral sense organs and the marginal and outer lateral on the dorsal side. The posterior nerve innervates the inner lateral and the median sense organs of the dorsal side. The innervation is pentannulate and dimeric, the two posterior rings of one somite being united with the three anterior rings of the next somite in the innervation.

The anal ganglion is clearly made up of seven somites, as indicated by the forty-two ganglionic sacs and the seven pairs of double nerves. The brain, including the supra- and sub-oesophageal ganglia, is likewise composed of seven fused somites. This is proved by the presence of forty-two ganglionic sacs and also by the peripheral distribution of the nerves. Altogether, then, the body of *Hirudo* consists of thirty-five segments, seven in the head, twenty-one in the body and seven in the caudal region.

V. E. MCCASKILL.

#### THE AXES OF THE ANNELID EGG.

THE unfertilized egg of *Arenicola cristata* is flattened and elongated, thus possessing three axes of unequal lengths—approximately 1:1.8:2.2. The germinal vesicle lies somewhat nearer one end of the shortest axis and thus furnishes the only means of orientation at this

time, since the cytoplasmic structure is uniform. Direct proof of the coincidence of these axes with those found at later stages is thus impossible, but the probability of coincidence is great.

At the time of formation of the first polar spindle the relations of the axes are 1:1.66:2.00; after fertilization and before cleavage and in the resting stages of two and four cells 1:1.37:1.50, eight cell stage 1:1.27:1.27.

In all cases the polar axis is the shortest, and, after cleavage begins, the longest axis is always parallel to the second cleavage plane and the third axis parallel to the first cleavage plane. Thus the first cleavage-spindle lies in the longest axis. In later stages the egg approaches a spherical form. The constancy of the axes in all cases where orientation is possible renders it extremely probable that they are always constant. The two long axes coincide with none of the axes of the adult, but are parallel with the first two cleavage planes.

C. M. CHILD.

Reviews and other papers presented during the quarter: 'Professor Minot on the Ancestry of Vertebrates,' A. L. Treadwell; 'Spermatogenesis of the Rat' (von Lenhossék), M. F. Guyer; 'Finer Anatomy of the Nerve Cell' (van Gehuchten), G. W. Hunter; 'Origin and Variation of the Wing-bars of Pigeons,' Dr. C. O. Whitman; 'Structure and Development of the Lens in Lower Vertebrates' (Rabl), Miss E. R. Gregory; 'Luminous Organs of Vertebrates,' Dr. S. Watasé; 'Cell-Lineage and Ancestral Reminiscences' (Wilson), A. L. Treadwell; 'The Placentation of Perameles' (Hill), Dr. W. M. Wheeler; 'The Eyes of Amphioxus' (Hesse), Dr. W. M. Wheeler.

#### NEW BOOKS.

*The Nature and Development of Animal Intelligence.* WESLEY MILLS. New York, The Macmillan Company. 1898. Pp. x + 307. \$2.00.

*An Illustrated Flora of the United States, Canada and the British Possessions.* N. L. BRITTON and ADDISON BROWN. New York, Charles Scribner's Sons. 1898. Vol. III. Pp. xiv + 588. \$3.00.

# SCIENCE

EDITORIAL COMMITTEE: S. NEWCOMB, Mathematics; R. S. WOODWARD, Mechanics; E. C. PICKERING, Astronomy; T. C. MENDENHALL, Physics; R. H. THURSTON, Engineering; IRA REMSEN, Chemistry; J. LE CONTE, Geology; W. M. DAVIS, Physiography; O. C. MARSH, Paleontology; W. K. BROOKS, C. HART MERRIAM, Zoology; S. H. SCUDDER, Entomology; C. E. BESSEY, N. L. BRITTON, Botany; HENRY F. OSBORN, General Biology; C. S. MINOT, Embryology, Histology; H. P. BOWDITCH, Physiology; J. S. BILLINGS, Hygiene; J. MCKEEN CATTELL, Psychology; DANIEL G. BRINTON, J. W. POWELL, Anthropology.

FRIDAY, AUGUST 5, 1898.

## CONTENTS:

<i>The Boston Meeting of the American Association for the Advancement of Science</i> .....	141
<i>The Jurassic Formation on the Atlantic Coast—Supplement: PROFESSOR O. C. MARSH</i> .....	145
<i>Notes on the Geology of Jamaica: OSCAR H. HER-SHEY</i> .....	154
<i>Current Notes on Anthropology:—</i> <i>The Native American Languages; The Study of Decreased Natality; Mexican Flutes: PROFESSOR D. G. BRINTON</i> .....	155
<i>Scientific Notes and News:—</i> <i>The Maryland Geological Survey; General</i> .....	156
<i>University and Educational News</i> .....	161
<i>Discussion and Correspondence:—</i> <i>Science in the Bureau of Education: PROFESSOR JOHN GARDNER. 'The Psychology of Suggestion.' DR. BORIS SIDIS. Celluloid Films: DR. HERMAN S. DAVIS</i> .....	161
<i>Scientific Literature:—</i> <i>Bertrand's Au Pays des la-Rotsi: PROFESSOR WILLIAM LIBBEY. Rowley on the Art of Taxidermy: F. A. L. Fuertes on Water and Public Health: PROFESSOR W. P. MASON. van't Hoff on the Arrangement of Atoms in Space. Noyes and Milliken's Laboratory Experiments on the Class Reactions and Identification of Organic Substances: PROFESSOR W. A. NOYES</i> .....	163
<i>Scientific Journals</i> .....	168
<i>New Books</i> .....	168

## THE BOSTON MEETING OF THE AMERICAN ASSOCIATION FOR THE ADVANCEMENT OF SCIENCE.

THE Fiftieth Anniversary of the American Association might well have been celebrated a year ago and, most fittingly, in Boston, for it was there, in 1847, that the Association of American Geologists determined to abandon the name and organization of a society which had enjoyed a prosperous existence for seven or eight years and by enlarging its scope and membership create the American Association for the Advancement of Science. In reference to this act, *Silliman's Journal*, in its first issue after the meeting, says: "The most important step taken at this meeting was the enlargement of the sphere of operations in this Association and a corresponding change of name, 'The American Association for the Promotion of Science,' is hereafter to be its designation, and it is designed to embrace all laborers in Physical Science and Natural History. Hitherto but few papers have been read on Chemistry, Natural Philosophy and General Zoology, the title of the Association appearing to many to exclude these topics. A corresponding increase of valuable papers

and collaborators it is anticipated will follow this desirable change."

The first meeting of the Association was held in Philadelphia, beginning September 20, 1848. The meeting was called to order by Professor W. B. Rogers, who was the last President of the 'Association of American Geologists and Naturalists.' A Committee had been appointed at the Boston meeting to draft a Constitution and Rules for the new body, and the report of this Committee was the first business considered. It was unanimously adopted and at 4 p. m. the American Association for the Advancement of Science was formally in session, under the Presidency of Wm. C. Redfield, who had been elected at the Boston meeting in accordance with the excellent practice of the earlier Association.

Some features of the first Constitution are worthy of notice. The rules relating to membership were a little peculiar. Certain persons were allowed to become members on their own volition, by signing the Constitution. They were members of other scientific or learned bodies publishing transactions, 'Collegiate Professors of Natural History, Physics, Chemistry, Mathematics and Political Economy, and of the Theoretical and Applied Sciences generally;' also civil engineers, architects and others who have been employed on public works. Persons not included in these classes might become members on nomination by the Standing Committee and election by a vote of the majority of the members present.

The honor of reading the first paper before the Association belongs to Peter A.

Browne, LL.D., of Philadelphia, President of the Society for the Development of the Mineral Resources of the United States. The title of this paper was 'Some Notice of the Fossil Cephalopodes *Belemnosepia*, long known by the name of *Belemnite*, and of the Diphosphate of Iron, called 'Mullite,' found together at Mullica Hill,' from which it will appear that the programs of the early days 'bristled' in much the same way as at present. On Friday evening, September 22, 1848, the Association held its first public, general session, a meeting that the modern program-maker would have set down as 'complimentary to the city of Philadelphia,' and complimentary to their intelligence it was, for its program included, in addition to the address of the retiring President (which was characterized as an 'extremely interesting and spirited discourse'), a paper on 'The General Principles of Analytical Mechanics' by Benjamin Peirce, and one on 'The Classification of the Animal Kingdom' by Louis Agassiz.

The Association adjourned on Monday, September 25th, with an enrolled membership of 461. The list begins with the name of Professor Stephen Alexander, of Princeton, and ends with that of Professor Ira Young, of Hanover, father of the distinguished astronomer, Professor C. A. Young, of Princeton. Active in the business of the meeting was Professor James Hall, of Albany, whom all members of the Association still delight to honor at its annual sessions. Of the total four hundred and sixty-one, besides Professor Hall, only six survive—Samuel L. Abbott, Martin H.



Boyé, Epes S. Dixwell, Wolcott Gibbs, Oliver P. Hubbard, Charles E. West.

It is not intended at this time and place to write a history of the Association, but only to suggest such comparison between its spirit and work in the earlier stages of its existence and in later years as may, possibly, indicate ways of bettering present conditions.

That the Association has been of incalculable value to American science no one can deny. The first Constitution declares its objects to be, "by periodical and migratory meetings, to promote intercourse between those who are cultivating science in different parts of the United States; to give a stronger and more general impulse and a more systematic direction to scientific research in our country, and to procure for the labors of scientific men increased facilities and a wider usefulness." This declaration is still retained in the organic law of the Society, except that its jurisdiction has been enlarged by substituting the word 'America' for 'United States' and omitting 'our country.' It is principally by 'promoting intercourse between those who are cultivating science' that the Association has been beneficial. The enormous extent of territory over which its membership is scattered has been at once a decided obstacle to that intercourse and the strongest reason for it. Hardly anywhere else in the world has the man of science been so isolated as in this country. The early and wide diffusion of public education resulted in the establishment of a large number of institutions for advanced instruction widely distributed over the States and Territories.

However imperfect they may have been in many respects, nearly every one became a nucleus of scientific activity and from them have come some of the finest contributions to science of which America can boast.

The inspiration which came to hundreds of young men through personal intercourse at the annual meetings of the Association—intercourse not only with the recognized leaders in science, but with each other—was worth many times what these meetings cost, directly or indirectly. During perhaps the first thirty years of its history the American Association was the one and only great scientific body of this Continent. Its meetings were attended by all men of distinction in all departments of science, and its influence in all matters relating to science was great. Although a popular body, admission to which was easy, its affairs were in the main directed and controlled by the 'select' in science, and the standard of its work was well maintained. The presence at its meetings of the highest authorities in special departments of learning unquestionably, although perhaps unconsciously, served as a check upon communications of a vague and uncertain character. The charlatan was not much in evidence in those days and generally had little mercy accorded him. The 'migratory meetings' of the Association were blessings to the communities in which they were held, often stirring the people to an interest in science and an appreciation of the importance of scientific men that lasted for years and resulted in largely increased facilities for scientific work. The people everywhere knew something of the very

first men of science and gladly paid the cost of publishing the Annual Proceedings and of the entertainment of the Association for the privilege of seeing and hearing them, and many an endowment for science had its origin in the enthusiasm created by the presence and speech of these men.

But those who have attended the meetings of the Association pretty steadily during the past quarter of a century know, and many regret, that during the past fifteen or twenty years there has been a very considerable change in its relation to the science of the country and in the influence which it is able to exert in all matters relating thereto. There is no doubt that much of this is the legitimate outcome of an evolution which has been almost a revolution, and which has affected many other institutions even in a more marked degree. The tremendous movement towards specialization which has taken place during the past one or two decades has not been entirely beneficial to the interests of science and scientific men. The American Association has been most seriously affected by it, through the organization of numerous societies of and for specialists, which have materially diminished interest in the general organization. To this must be added the influence of the organization in 1864 of the National Academy of Sciences and especially its practical reorganization ten years later. As the only scientific body to which admission is to be gained only by character and importance of scientific work, the Academy is naturally and properly the aspiration of young men of science. It has indirectly worked an injury, however, to

the American Association by the fact that many men of first rank find it difficult to attend meetings of both societies, and it is a notable fact that many later meetings of the Association have been conspicuous by the absence of a large majority of the leaders of American science. This absence, which is, perhaps, oftener to be attributed to lack of disposition than anything else, is doubly unfortunate because it removes one of the most important attractions to younger men of science.

The creation of special organizations, such as the Geological Society of America, the American Chemical Society, the American Society of Naturalists, and others, has been one of the most serious blows to the American Association. In 1881 it sought to meet the growing demand for specialization by breaking up into sections, but for some reason this has not satisfied the desire of the specialists. It is gratifying to record the fact that among some of the more recent organizations a better spirit towards the older society has prevailed during the past two or three years, and there is an evident disposition toward cooperation which the latter ought quickly to take advantage of. Indeed, it is to be hoped that a way may yet and soon be found for further cooperation between these societies and the Association, it being evident that all may be greatly benefited thereby.

Many men, eminent in science to-day, owe much of their prominence to opportunities which came to them through the meetings of the American Association a score or more years ago. With them and all, indeed, the obligation to sustain and

foster the interests of the Association ought to be imperative. Through its semi-popular character and close touch with the people, many things have been 'set going' to the great advantage of the members of the National Academy and of other more or less exclusive bodies, but they will not, of themselves, keep going forever. It will be a sorry day for science when the general public is compelled to depend upon the columns of such a press as at the present time enlightens and instructs its readers in matters scientific. If for no other reason, the best men in science might well afford to join the Association in its migratory meetings, that the people might have a chance to know real science in contrast with the quackery and humbug which is now daily served out to them. This is preeminently a function of this organization and one which cannot be assumed by the National Academy of Sciences, or any of the specialized groups. The same may be said of the importance of the Association in exercising a wise influence over public sentiment in reference to all questions of general interest in which science is in any way involved. From the beginning this has been one of its most valued and valuable features. Allied to no other organization or State or National Government, it has always dared to speak its mind and in no uncertain way. The National Academy, although the scientific adviser of the government, is almost useless in this respect, because it waits until its advice is sought. There is, and always will be, great need for a strong representative scientific body, unrelated to political parties or government

bureaus, through which the consensus of opinion of scientific men of the country may find free expression, especially in regard to the scientific work and interests of the government. In view of the rapidly increasing tendency towards centralization of scientific work in the government, and the constant dangers by which such work is threatened when under government control (a danger quite as likely to grow up within as to come from without), it will be well worth while to maintain the Association for this purpose, if for no other.

The meeting in Boston must necessarily be one of great moment. As the fiftieth anniversary meeting it will attract many of the older members who have not generally attended recent meetings, and many young lovers of science who may with great profit to themselves join its ranks. The place and the time are both encouraging, and SCIENCE hopes that the interest and enthusiasm that is sure to be awakened may be such as to lead to a better appreciation of the dignity and importance of the organization on the part of the leaders of American science, and to such a readjustment of its internal policy and external relations as will best fit it for the great work which it will be called upon to do during the next half century.

---

*THE JURASSIC FORMATION ON THE  
ATLANTIC COAST—SUPPLEMENT.\**

At the autumn meeting of the National Academy last year, in New York, I made a communication entitled 'The Jurassic For-

\* Abstract of a communication made to the National Academy of Sciences, Boston meeting, November 18, 1897.

mation on the Atlantic Coast.\* In this paper I brought together the results of a careful investigation which I had been conducting for several years, going to prove that the Jurassic formation, generally supposed to be wanting on the Atlantic border, was represented by a definite series of strata in the exact position where such deposits were to be expected. Accompanying this communication, I exhibited a number of drawings and sections illustrating the Jurassic deposits of the West, which I had long before investigated and fully described, namely, the Baptaodon beds, consisting of marine Jurassic strata with many characteristic fossils, mostly invertebrates, and above these the fresh-water *Atlantosaurus* beds, which have yielded such vast numbers of gigantic reptiles and other characteristic vertebrates. Sections showing the relative positions of these deposits, with the strata above and below them as they are seen in several localities in Wyoming and Colorado, were also exhibited.

In comparison with this great development of the Jurassic in the West, I next discussed the so-called Potomac formation in Maryland, in which I had found a corresponding vertebrate fauna that proved the strata containing them to be also of Jurassic age. I then gave a brief account of my researches during that season, in following essentially the same strata to the eastward through Delaware and New Jersey, and likewise presented evidence showing that apparently the same Jurassic beds were to be found in position beneath Long Island, Block Island and Martha's Vineyard, represented by the variegated basal clays of these islands, which had previously been supposed to be of much later age. The evidence seemed conclusive that in this series we had remnants of an extensive

formation of fresh-water origin, the strata consisting mainly of soft sandstones and plastic clays of great thickness. In their physical characters, and especially in their variegated brilliant colors, these deposits differed widely from any others known on the Atlantic border, and were only equalled in this respect by the Jurassic beds of the Rocky Mountain region. The presence on the Atlantic coast of such an extensive formation, with its massive beds of plastic clay, all of fresh-water origin, clearly proved the former existence of a great barrier between the basin in which these clays were deposited and the Atlantic Ocean, a barrier that has long since disappeared through subsidence, or was broken down by the waves of the Atlantic, which are still rapidly removing the remnants of the formation along its eastern exposure, as may be seen on Block Island and at Gay Head on Martha's Vineyard.

In discussing the age of this formation, its position above the Triassic and below the marine Cretaceous, its characteristic physical characters, distinct from those above and below, and its western extension into the strata of undoubted Jurassic age in the Potomac beds of Maryland, all pointed to the conclusion that its members belong to the same general epoch and were deposited during Jurassic time.

In the paper thus cited I confined myself strictly to the Potomac formation north of the Potomac River, and what I believed to be its eastern extension as far as Martha's Vineyard, all of which I had personally explored. I particularly avoided any discussion of the so-called Potomac beds south of the Potomac River, although I had been over these deposits at various points along the Atlantic border and around the Gulf as far as the Mississippi River. I closed the paper with the promise of taking up that part of the subject later.

As the question was a difficult one and

\* SCIENCE, Vol. IV., p 805, December 4, 1896. See also *American Journal of Science*, Vol. II., p. 295, 375 and 433, 1896.



still under investigation, I likewise guarded myself against expressing the opinion that all the so-called Potomac deposits were Jurassic. My words on this point were as follows :

"It cannot, of course, be positively asserted at present that the entire series now known as Potomac is all Jurassic, or represents the whole Jurassic. The Lias appears to be wanting, and some of the upper strata may possibly prove to belong to the Dakota."<sup>\*</sup>

#### THE DAKOTA SANDSTONE.

In regard to the sandstone known as Dakota, and generally considered of Cretaceous age, I spoke cautiously, as behooves anyone who has seen this formation at many of its outcrops over a wide range of territory in the West, where its physical characters are striking and its fossil remains are mainly detached leaves of plants.

In figure 1 of my paper, showing geological horizons and designed especially to represent the succession of vertebrate life in the West during Mesozoic and Cenozoic time, and so defined in the text, I left a blank space above the Jurassic for the Dakota, exactly where I had found a sandstone, regarded as Dakota, in place at many widely separated localities. I said little about the Dakota itself, as I did not wish then to raise questions outside the scope of my paper.

Had the occasion been appropriate, I might have said that the group termed Dakota in my section I consider as more extensive than the single series of sandstones defined as Dakota by Meek and Hayden in 1861. The original locality of this sandstone was the bluffs near the Missouri River in Dakota County, Nebraska, and these authors included with this the supposed southern extension of the sandstone in eastern Kansas. This placed the Da-

kota on the eastern margin of the great Cretaceous basin which extended westward to the Rocky Mountains. The attempt of Meek and Hayden to identify the Dakota further north, near the mouth of the Judith River, is now known to have failed, but the name transferred to certain sandstones along the flanks of the Rocky Mountains has been accepted, and this term has long been in use for these strata from Canada to Mexico. With this so-called Dakota sandstone, however, have been included other deposits, the upper part of which may be Cretaceous, while the rest I regard as Jurassic, and with good reason. These intermediate beds may be seen at various places, especially around the border of the Black Hills and along the eastern flanks of the Rocky Mountains in Colorado. As I shall refer to this point later in the present communication, I will not discuss it here.

#### OPINIONS OF VARIOUS GEOLOGISTS.

The paper I have now cited I regarded as the preliminary statement of an important case, and not its final demonstration. When presented to the Academy it received the general approval of the members interested in the subject, and one of them, the late Professor Cope, who was best qualified to weigh the evidence of paleontology, fully endorsed my conclusions, and added that he himself had long suspected that the strata under discussion would prove to be of Jurassic age.

When an abstract of my communication was published, although without the main illustrations shown to the Academy, I received further endorsement from geologists familiar with the subject, but from others marks of disapproval predominated. This I had anticipated in a measure, especially from the paleobotanists, whom I believed responsible for much of the confusion that had so long delayed the solution of similar questions, East and West. This point I

<sup>\*</sup>SCIENCE, Vol. IV., p. 807, 1896.

brought out in my paper, but in an impersonal manner that I hoped would offend none of the craft.

The prompt and vigorous rejoinders that even my first informal announcement drew from two paleobotanists, A. Hollick and L. F. Ward,\* showed that I had trespassed upon their bailiwick, and that some of the questions raised they had settled to their own satisfaction. As their ideas in regard to the value of fragmentary fossil plants as evidence of geologic age differed so widely from my own and from those of many paleontologists, no specific reply on my part seemed necessary, and I have none to make now. Professor Ward has admitted that the plants found with the vertebrates in the Potomac beds of Maryland may be Jurassic, and that removes one of the main points at issue between us. His words are as follows :

"If the stratigraphical relations and the animal remains shall finally require its reference to the Jurassic the plants do not present any serious obstacle to such reference." (Loc. cit., p. 759.)

That the more eastern beds may represent a somewhat higher horizon I can readily believe, but I must doubt the evidence that would separate so characteristic and homogeneous a series of sands and plastic clays into two sections, one Cretaceous and the other Jurassic. The few imperfect plant remains that we are told authorize this separation must be reinforced by other testimony to obtain even the support of probability, especially when paleobotanists differ so widely among themselves as to the real significance of the fragmentary remains they describe.

Next in order among my reviewers was R. T. Hill,† well known for his researches in the geology of Texas, but apparently not familiar with the typical Jurassic, East or

West. He evidently had not read my paper carefully, though he criticises it at length, mainly to confirm his own conclusions as to the Cretaceous age of certain deposits in Texas, which he seems to imagine I do not endorse. As I especially avoided expressing any opinion on that point, or in regard to the Dakota being the base of the Cretaceous in this country, as I have already stated, no reply at present seems called for on my part, although I hope later to refer to the question he raises about the age of the so-called southern Potomac.

I took it for granted, in my paper cited, that American geologists who were not familiar personally with the great development of the Jurassic formation in Europe, or who had no opportunity of examining typical sections of this formation in western America, or of seeing its deposits in place full of characteristic fossils and extending hundreds of miles in half a dozen States, were at least sufficiently acquainted with the literature of the last twenty years to know that two of the best-marked Jurassic horizons in any part of the world existed in this country.

Although my communication, as printed, was in fairly clear English, I find it was misunderstood in various other points, as subsequent reviews soon showed. If these marks of disapproval had been recorded by fireside geologists, who so often differ with those who furnish facts, I should have followed my usual rule and made no reply. They were, however, mainly written by field geologists who had seen something of the West, and ought evidently to have seen more, for the facts I stated can be readily verified at any of the localities mentioned and at many others. The failure to do so well illustrates a law of human nature, namely, that men see what they have eyes to see. The West is an extensive country. The plant men who go there seem to see

\* SCIENCE, Vol. IV., p. 571 and 757, 1896.

† SCIENCE, Vol. IV., p. 918, 1896.

only fossil plants; the invertebrate collectors notice only their own favorites, and, as both classes are numerous, the extinct vertebrates are too often overlooked or only peculiar and striking specimens secured. Thus the most valuable evidence as to the age of strata is neglected, and the decision rendered has so frequently to be reversed. This neglect is not confined to field work alone, where fossil vertebrates should be found, but too often extends to the literature of the subject.

Let me illustrate this by a short quotation from a well-known work:

"The Jurassic system, which is so largely developed in Europe, containing the remains of huge swimming and flying reptiles \* \* \* is but sparingly represented in American geology, and none of the gigantic vertebrates have as yet been found here."\*

The above extract may fairly be taken as representing the information on the subject known to the authors, or at least to the editor when this work was published. It is, moreover, a fair sample of much that has since been written about the Jurassic formation of this country and its fossil contents, especially by those not familiar with this subject, but whose work in allied fields should at least have made them acquainted with the main results of our vertebrate paleontology, which had become a part of the world's scientific knowledge.

For example, at the time the above work was published, one of the most fruitful horizons of vertebrate fossils ever discovered had been known for several years in the Jurassic of the West. Many tons of gigantic fossil vertebrates had been collected from several localities, and the principal forms described and figured, while the illustrations had been reproduced even in text-books. Moreover, the Jurassic horizon in which these and other remains were

found had been definitely determined and named the *Atlantosaurus* beds, and a geological section showing their position and characteristic genera had been published several times. The fossils thus discovered embraced mammals, birds, reptiles and fishes, nearly all of well-marked Jurassic types.

Since 1880, when the statement I have quoted was made, other discoveries have followed in rapid succession, and the Jurassic vertebrate fauna of the West is now known to be a most rich and varied one, far in advance of that from any other part of the world. More than one hundred and fifty species of extinct vertebrates, some of them represented by hundreds of specimens, have been brought to light, and over one hundred of these have already been described, and the more important have been refigured and republished in various parts of the world, including text-books, so that anyone with even an elementary knowledge of the subject can see that they are Jurassic in type. Nevertheless, a number of American geologists whose studies have kept them in other fields still appear to be ignorant of nearly all that has been made known about vertebrate paleontology in this country during the last quarter of a century, and seem to think that the Jurassic formation here is of small importance, and that its area should be restricted rather than enlarged.

Another of my reviewers was G. K. Gilbert, editor of the work from which I have just quoted. Whether he intended his remarks on my paper to be taken seriously is not clear. Apparently he wished to start an academic discussion on correlation, and under the circumstances this would probably have led from the Rocky Mountains to the Mountains of the Moon, one of his latest fields of investigation. If he is really in doubt about the methods of correlation of vertebrate fossils he can per-

\*Geology of the Black Hills, by Newton and Jenney, edited by G. K. Gilbert, p. 151, 1880.



haps find the information he needs in textbooks.

First of all, however, I must question the accuracy of some of the statements in his review of my paper. One of these is as follows :

"Through a comparison of vertebrates from the Potomac formation with vertebrates from other formations he has inferred the Jurassic age of the Potomac, but he gives no hint of the character of his evidence or the course of his reasoning."\*

Had this critic read the whole of my paper he would have found the following statement bearing on this point :

"The Jurassic age of the *Atlantosaurus* beds of the West has now been demonstrated beyond question by the presence of a rich fauna of mammals, birds, reptiles and fishes. Among these, the *Sauropoda* were dominant, and the other *Dinosaurs* well represented.

"In the Potomac beds of Maryland the same Jurassic vertebrate fauna is present, as shown by the remains of five different orders of reptiles already discovered in them. Among the *Dinosaurs* are the *Sauropoda*, the *Theropoda* and the *Predentata*, the first group represented by several genera and a great number of individuals. One of these genera is *Pleurocalus*, which has also been found in the Jurassic of the West. Besides the *Dinosaurs*, characteristic remains of *Crocodylia* and *Testudinata* are not uncommon, and various Fishes have been found. The remains of these six groups already known are amply sufficient to determine the age of the formation, and still more important discoveries doubtless await careful exploration."†

Mr. Gilbert's next statement, which is also without real foundation, is as follows :

"The conclusion that the *Atlantosaurus* and other horizons of the Rocky Mountain

region are Jurassic was announced in the same way, without citation of evidence."

The announcement of the *Atlantosaurus* beds as Jurassic was accompanied by a section showing their exact position in the geological scale, and the characteristic genera of *Reptilia* which then indicated their Jurassic age.\* This was followed by descriptions, in rapid succession, of many other vertebrate fossils, proving beyond question that the horizon was Jurassic. The *Baptanodon* beds were also defined, and their position in the geological series established by characteristic fossils. The demonstration on this point I have already given above and need not repeat here.

Another point needs correction, as Mr. Gilbert evidently consulted my recent classification of the *Dinosauria*† without appreciating the evidence it contained. This is shown by the following quotation from his review :

"The closest affinity of the European and American formations seems to be expressed by the statement that there is one American genus which falls in the same family with a European genus."

The genera named in my recent classification were mainly typical forms, and I had no intention of making a complete catalogue of all the known genera, as anyone familiar with the subject could readily see. By way of further instruction, let me repeat here what I have recently said about one of these typical forms.

"*Pleurocalus* is one of the most characteristic genera of the *Sauropodous Dinosauria*, and its value in marking a geological horizon should, therefore, have considerable weight. It is now known from the two European localities mentioned above, both

\*Proceedings of the American Association, Nashville meeting, p. 220, 1878; see also *Popular Science Monthly*, p. 520, March, 1878.

†The *Dinosaurs of North America*, 16th Annual Report U. S. Geological Survey, p. 233, 1896.

\*SCIENCE, Vol. IV., p. 876, 1896.

†SCIENCE, Vol. IV., p. 814, 1896.



in strata of undoubted Jurassic age. The same genus is well represented in the Potomac deposits of Maryland, and has been found, also, in the *Atlantosaurus* beds of Wyoming, thus offering, with the associated fossils, strong testimony that the American and European localities are in the same general horizon of the upper Jurassic."\*

Had Mr. Gilbert been familiar with the subject discussed in his review he would have known that, so far as present evidence goes, there are other genera of Dinosaurs common to Europe and America, found in apparently the same Jurassic horizon, and that this is true also of various other reptiles and of fishes. More important still is the correspondence between the genera of Jurassic mammals of the two continents,

in question are in favor of their Jurassic age, and the Potomac strata do not pass by insensible gradation into the marine Cretaceous above. Although the two are apparently conformable, the passage from one to the other was a change from fresh-water to marine deposits, which in itself implies a break that may represent a long period of time, perhaps the entire Lower Cretaceous. This break was clearly indicated in the geological section that I gave in my paper (figure 2), and to make this point clear the same section is here repeated.

This typical section represents the successive Mesozoic and more recent formations, from New Brunswick, New Jersey, on a line southeast, through Lower Squankum to the Atlantic. The distance indicated is about forty miles.

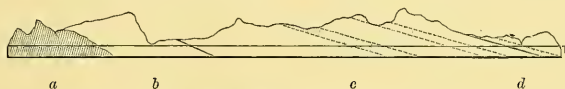

Geological Section in New Jersey.

a, Triassic; b, Jurassic; c, Cretaceous; d, Tertiary; T, tide level.

which in itself is sufficient to demonstrate that they belong in essentially the same horizon.

The last point Mr. Gilbert raises in his review is a geological one, and even here he has missed the mark. His words are as follows:

"The physical relations of the beds afford a presumption in favor of their Cretaceous age. Professor Marsh mentions that the Potomac formation in New Jersey passes by insensible gradation into marine Cretaceous above."

The two statements in this quotation are, in my opinion, both erroneous, and the second is contrary to the idea I intended to convey. The physical relations of the beds

My explanation was as follows:

"The change from the fresh-water plastic clays of New Jersey to the marine beds containing greensand over them proves not only the breaking down of the eastern barrier which protected the former strata from the Atlantic, but a great subsidence also, since glauconite, as a rule, is only deposited in the deep, still waters of the ocean."\*

Since my paper was published, I have been over part of this section several times, and found clear indications of the break itself. Moreover, Professor W. B. Clark, of Baltimore, informs me that he finds distinct unconformity between the marine Cretaceous and the underlying Potomac, along the junction of these two formations, at various other points further south. This

\* *American Journal of Science*, Vol. IV., p. 415, December, 1897.

\* SCIENCE, Vol. IV., p. 812, 1896.

fact furnishes a strong argument that the marine Cretaceous belongs to a separate formation from the older fresh-water clays, here regarded as Jurassic.

Another geologist who has written much about the West, but seems to have failed in comprehending the evidence afforded by the vertebrate fossils from well-marked Jurassic horizons, is C. A. White, and, as his opinion is frequently quoted, it may be well to correct one of his statements which bears on the question here discussed. In speaking of the *Atlantosaurus* beds, in 1889, he made this statement :

"If it were not for their dinosaurian faunas their Jurassic age might well be questioned."\*

When this statement was made, more than one hundred species of vertebrate fossils besides the Dinosaurs were known from these same *Atlantosaurus* beds, and among these the Crocodylians, the Testudinates and the various smaller reptiles would have been sufficient to demonstrate the Jurassic age of the strata containing them. More important still, several hundred specimens of Jurassic mammals had been found, over a score of species were already described and figured, and these alone were sufficient to prove the horizon Jurassic.

Following these well-known writers, others of less experience in the West have repeated their statements or followed the earlier geologists as to the age of western horizons, and thus tended to continue the confusion where the facts themselves made the whole subject clear. Thus it has come to pass that while the Jurassic formation has been recognized in the Arctic regions of this Continent, and along the Pacific coast, especially through Oregon and California, as well as in Mexico, and likewise in various parts of South America, its development in the Rocky Mountain region

has received little attention except from those especially engaged in its investigation. It is not strange, then, that those who have not seen how extensive the Jurassic formation is developed in Europe, and have not examined its characteristic exposures in the West, should fail to recognize it on the Atlantic coast where its features at many points are obscure.

In my paper on this subject last year I endeavored to show that the burden of proof must rest upon those who denied the existence of the Jurassic formation on the Atlantic border. The evidence against it is still based mainly upon fragmentary fossil plants, in regard to the nature of which the paleobotanists themselves are not in accord.

#### CYCAD HORIZONS.

I have recorded elsewhere my opinion of the comparative value of different kinds of fossils—vertebrates, invertebrates and plants—as evidence of geological age, and have endeavored to show that plants, as usually preserved and described, are the least valuable witnesses. The evidence of detached fossil leaves and other fragments of foliage that may have been carried hundreds of miles by wind and stream, or swept down to the sea-level from the lofty mountains where they grew, should have but little weight in determining the age of the special strata in which they are imbedded, and failure to recognize this fact has led to many erroneous opinions in regard to geological time. There are, however, fossil plants that are more reliable witnesses as to the period in which they lived. Those found on the spot where they grew, with their most characteristic parts preserved, may furnish important evidence as to their own nature and geological age. Characteristic examples are found among the plants of the Coal Measures, in the Cycads of Mesozoic strata, and in the fossil forests of Tertiary and more recent deposits.

\* Proceedings of the American Association, Toronto meeting, p. 213, 1890.

As bearing directly on the question here discussed, the Cycads of the Jurassic period afford instructive examples of the evidence that may be derived from fossil plants under favorable circumstances. The Cycad trunks of the upper Jurassic of England have long been known, and are especially interesting from the fact that many of them are found imbedded in the original soil in which they grew, thus marking a definite horizon, the age of which has been ascertained by independent testimony.

On the Atlantic border of this country we have a corresponding horizon, determined to be such by its position and by the vertebrate fossils it contains. At various localities in this horizon, especially in Maryland, Cycad trunks have long been known, and within a few years numbers of very perfect specimens have been found under circumstances that serve to fix the horizon in which they occur, and confirm the evidence as to its geological age.

In the Rocky Mountain region, especially around the margin of the Black Hills, a definite horizon likewise exists, in which great numbers of Cycad trunks are found in remarkable preservation. These Cycads resemble most nearly those from Maryland, found in what I term the *Pleurocœlus* beds of the Potomac formation. In the Black Hills the age of the horizon has not been accurately determined, but present evidence points to its Jurassic age. The strata here containing these characteristic fossils has long been referred to the Dakota, but, as I have already shown in the present paper, the beds so termed in the Rocky Mountain region are not the equivalents of the original Dakota, and some of them are evidently Jurassic. Until recently the Cycads of the Black Hills, although of great size and remarkable preservation, have not been found actually in place. In the large collection of Cycads belonging to the Yale Museum a few have

been discovered apparently where they grew, and systematic investigation will doubtless show that the various localities where these fossils have been found around the Black Hills are all in one horizon. The evidence now available indicates its Jurassic age, and suggests that it is essentially the same as that of the Cycad beds in Maryland, which I regard as a near equivalent of the well-known Cycad horizon in the Purbeck of England.

In conclusion, I have only to say that the year which has passed since my first communication to the National Academy on the Jurassic of the Atlantic border has brought no important evidence against the view I then maintained, but much additional testimony in its favor, especially in the region north of the Potomac River that I then discussed. I still hope to return to the subject later and take up the question of the extension of the same formation along the Atlantic coast farther south, and around the Gulf border to the southwest, where new evidence is now coming to light.

*Postscript.*

After the preceding article was in print I received some information about Cycad horizons in Wyoming that bore directly on the question I discussed near the end of my paper. This information is of so much interest that I add a postscript to place on record the important discovery by W. H. Reed of two new Cycad localities in the Jurassic of Wyoming, both much farther west and quite distinct from those already known around the Black Hills. One is in the Freeze Out Hills of Carbon county, and the other near the Wind River range.

Mr. Reed has since sent me a more complete account of the first of these localities, with a sketch showing the section of the strata where the Cycads were found, and also measurements of the successive strata exposed, from the Trias

up to the so-called Dakota sandstone that caps the bluff at that point. The marine Baptonodon beds here show a thickness of thirty-five feet. Above these is a series of fresh-water sandstones and shales, sixty-six feet in thickness, which in places contain remains of *Laosaurus*, a typical Jurassic Dinosaur. Immediately above these the Cycads occur in a narrow layer of white sandstone, and with them are various fragments of bones. Next above are fifty-five feet of strata containing vertebrate fossils, apparently indicating the *Atlantosaurus* beds. Above these are thirty feet of barren clays, and over all is the sandstone regarded as Dakota.

Mr. Reed has also sent me specimens of the Cycads found at this locality. As he has had an experience of twenty years or more on the Jurassic of the West, and is otherwise admirably qualified to judge of such horizons, his opinion is entitled to great weight and should settle the question for this locality.

Mr. H. F. Wells, who has carefully explored the Black Hills Cycad horizon, and sent to the Yale Museum over one hundred specimens of these fossils, has also, at my request, sent me a section, made near Blackhawk, on the eastern rim of the hills, a region which I have myself examined, although not recently. This section indicates that the Cycad horizon there is also in the Jurassic, and not the Dakota, and this is borne out by other localities in the same vicinity.

Professor L. F. Ward has published sections examined by him on the southwestern border of the Black Hills in 1893. He found no Cycads actually in place, but decided that the horizon in which they occur is Cretaceous.\* I have recently placed in his hands for description all the Western Cycads in the Yale Museum. Our views, however, do not at present coincide as to the

age of the strata containing them, but the new facts which are now being brought to light will, I trust, soon place this matter beyond reasonable doubt.

O. C. MARSH.

YALE UNIVERSITY,

NEW HAVEN, CONN., July 18, 1898.

NOTES ON THE GEOLOGY OF JAMAICA.

THE eastern portion of the island of Jamaica, in the West Indies, is remarkable for its high abrupt mountains, whose ragged outlines resemble those of the high sierras (not the volcanic ranges) of the Pacific side of Central America and Mexico. These mountains rise steeply from the ocean east of Kingston on the south side and near Port Antonio on the north side of the island, and in Blue Mountain peak attain an altitude of about 7,000 feet. The topography is essentially that of subaerial erosion, the sharp rocky mountain ridges being due to the excavation of deep narrow stream valleys in a great uplift which originally extended beyond the limits of the island.

So far as I have been able to learn from observation and conversation with residents, the entire mass of this Blue Mountain system, in the eastern end of the island, is composed of one great white limestone formation. This may be soft and chalky; it may be brecciated and in places quasi-conglomeratic; it may be a hard compact fine-grained sub-crystalline white limestone nearly free from fossils, as in the case of the material used for macadam in the streets of Kingston; or the same white limestone abundantly fossiliferous, as at Port Antonio. This latter locality is an interesting one. Reef-building coral species are numerous represented in the mass of the rock, and the white formation is evidently a coralline limestone. There are the casts of many other marine species of shell-bearing animals, particularly gasteropods and allied

\* *Journal of Geology*, Vol. II., p. 250, 1894.



forms. I make no pretensions to expertness in paleontological knowledge, but the fossil fauna at Port Antonio impressed me as being of an Eocene facies. On the Isthmus of Panama, where the horizon is due in the column of strata, there is nothing at all representing this immense coralline limestone of Jamaica. But in Citrus county, Florida, I studied, several years ago, a white coralline Eocene limestone, which seems to me to have a fauna of a facies similar to that at Port Antonio. Certainly there is a remarkably close resemblance between the two formations. If they are parts of the same formation, or limestones formed under like conditions and of the same age, the Blue Mountains of Jamaica consist of a deeply eroded massive 'uplift' of the Vicksburg-Jackson limestone, as the Eocene coralline limestone of the southeastern portion of the United States has been named.

The railroad between Kingston and Port Antonio is built over the white limestone nearly all the way. But for some short distance on the north of the divide and south of Morant Bay the many cuts expose a heavy series of soft or semi-lithified clays, which are probably newer than the limestone.

The only other formation of any importance which was observed on the island is a gravel deposit of Quaternary age which forms an even but gently sloping plain between Kingston and Spanish Town and is represented at intervals on the north coast, where it forms uneven terraces of no great height, indicating apparently a slight uplift of the island in some not very late part of the Quaternary Era.

OSCAR H. HERSHEY.

FREEMPORT, ILL., June 24, 1898.

#### CURRENT NOTES ON ANTHROPOLOGY.

##### NATIVE AMERICAN LANGUAGES.

In the *Proceedings* of the Canadian Institute, May, 1898, the Rev. E. B. Glass

has a few pages on the Cree language. He discusses its euphony, precision, and the formation of its nouns.

The Rev. John Campbell prints another of his 'discoveries' in the *Transactions* of the Canadian Institute (May, 1898). The title is 'The Dénés of America identified with the Tungus of Asia.' Mr. Campbell has announced so many such discoveries that it is difficult to secure consideration for more of them.

The death of Professor Dr. Friederich Müller, of Vienna, which occurred May 25th, should not be allowed to pass without a tribute to his studies of American languages. In the second volume of his great work 'Grundriss der Sprachwissenschaft' (Vienna, 1882), he presented the analysis of forty-one native tongues and dialects spoken by the aborigenes of this continent, in accordance with the most rigid demands of science. He avoided the treacherous ground of verbal comparisons, and devoted his attention to morphology and grammatical structure. Both in extent and scholarly thoroughness, his work in this branch stands easily ahead of that of any other writer in this generation.

##### THE STUDY OF DECREASED NATALITY.

Few subjects in anthropology have more practical bearing than that of the decadence of races. This comes most directly from a diminished birth rate. It has been calculated that a minimum of four living children are required to each marriage under ordinary conditions in order merely to prevent diminution. Decrease in natality, therefore, is an ominous outlook for a community.

A study of it in the United States by Dr. K. R. Storer appeared some months ago (reprint from *Atlantic Monthly*, October, 1897). It is disappointing in both facts (?) and conclusions. With his full opportunities of observation he is quite unable to

present his statistics in scientific form. What nonsense to talk of the laws of decreased natality as 'a penalty inflicted for the sin of the people' (p. 32)! Or to attribute the greater fecundity of our foreign-born population to 'the watchful protection of the Roman Catholic Church' (p. 25), in face of the facts that a large percentage of the foreign-born are not Catholics, and in France, where 95 per cent. of the population are Catholic, the decrease of natality is more striking than in any other country! The topic must be studied in a very different spirit from this in order to reach results worth anything.

#### MEXICAN FLUTES.

A CONTRIBUTION by Professor Kollmann, of Basel, to the *Bastian Festschrift* should be mentioned, though it is a little late to refer to it.

The subject is a portion of the collection of Mexican antiquities brought to Basel about 1837 by Lucas Vischer. It includes a number of flutes and whistling jars of pottery, not materially unlike quantities of others in various museums. Professor Kollmann describes and figures them, speaks of their employment in religious and other ceremonies, and speculates as to their origin, seemingly leaning toward an 'Asiatic' suggestion. He is in error in supposing the flute was confined to the aborigines of Mexico and Central America. It was known to the Indians of Florida and elsewhere.

D. G. BRINTON.

UNIVERSITY OF PENNSYLVANIA.

---

#### SCIENTIFIC NOTES AND NEWS.

##### THE MARYLAND GEOLOGICAL SURVEY.

We learn from an article in the *Baltimore Sun* that the work of the Maryland Geological Survey, which is being carried on under the direction of Professor William Bullock Clark, of the Johns Hopkins University, State Geologist, is being pushed with vigor in several sections of

the State. A large area will be thoroughly surveyed during the present summer. At the same time the results of the previous work are being rapidly brought together for publication, and the second volume of the Survey Reports, much elaborated over earlier plans, will shortly appear.

The topographic work which is being carried on under an act of the last Legislature, in cooperation with the United States Geological Survey is making rapid strides in the mountainous portions of western Maryland and Garrett and Alleghany counties, and will be completed before the close of the field season. The geological work proper is being carried on at the present time in sections of western, southern and northern Maryland. A party of several geologists, under the direction of Dr. G. B. Shattuck, is studying the later Tertiary formations, with their marls, clays and gravels, in the southern counties, while associated with them during most of the season has been Dr. R. M. Bagg in a study of the earlier Tertiary of Anne Arundel and Prince George's counties. Mr. A. Bibbins is engaged in the study of the clays and iron carbonate deposits of the older coastal plain formations in Cecil and Harford counties, and their extension beyond the limit of the State.

The geology of the Piedmont belt is under the direction of Dr. E. B. Mathews, who has had associated with him in the study of the distribution of the basic eruptive rocks in the northern counties, especially Cecil, Harford and Baltimore, Dr. A. G. Leonard, who will spend the summer in tracing the distribution of these rocks across the State.

The geology of western Maryland, which is under the charge of Dr. Charles S. Prosser, is being investigated by him and Messrs. O'Harra, McLaughlin and Rowe, who have already nearly completed their work in this district. The magnetic survey of the State is being carried on under the direction of Dr. L. A. Bauer.

The new highway division of the Survey established by an act of the last Legislature is under the charge of Dr. H. F. Reid, who has associated with him Mr. A. N. Johnson as highway expert. These gentlemen, in conjunction with Professor Clark, have visited various sec-

tions of the State in the interest of investigation.

The State Geological Survey, in cooperation with the United States Department of Agriculture and State Experiment Station, has been making a special study of the distribution of soil types while the geological survey has been in progress. Mr. C. W. Dorsey has been in charge of this phase of the work. The connection between the soils and the indigenous plant life is readily apparent, and the Survey is paying some attention to the distribution of the flora of the State. Messrs. B. W. Barton and Basil Sollers are devoting a portion of the summer to this study.

#### GENERAL.

PROFESSOR J. R. EASTMAN, of the United States Naval Observatory, was retired from active service on July 29th. Professor Eastman has been continuously connected with the Observatory since 1862.

THE University of Edinburgh has conferred its honorary LL.D. on several of those who attended the recent meeting of the British Medical Association, including Professor H. P. Bowditch, of Harvard University, and Professor Wm. Osler, of Johns Hopkins University.

PROFESSOR VIRCHOW, of Berlin, will deliver the next Huxley lecture at the Charing-cross Hospital, on Wednesday, October 3d. The subject of the lecture, to be delivered by Professor Virchow in English, is 'Recent Advances in Science and their Bearing on Medicine and Surgery.'

SIR WILLIAM McCORMAC has been elected President of the Royal College of Surgeons of England for the third year; Mr. T. Pickering Pick and Mr. Howard Marsh have been elected Vice-Presidents for the ensuing collegiate year.

THE British Order of the Bath has been conferred on Professor D'Arcy W. Thompson.

DR. P. KUCKUCK has been appointed custodian for botany at the Heligoland Biological Institute.

DR. WILLIAM PEPPER, of Philadelphia, died of heart disease in San Francisco on the night of July 28th. Dr. Pepper belonged to a prominent Philadelphia family and was born in that

city in 1843. He was connected with the University of Pennsylvania in many capacities from the time he entered as a student, being provost from 1881 until 1894, and at the time of his death professor of the theory and practice of medicine. Dr. Pepper was the author of many works on medical and other subjects, the most important of which was his 'System of Medicine by American Authors.' He also founded the *Philadelphia Medical Times*. Dr. Pepper was prominent in many of the public institutions of Philadelphia, and to his initiative, ability and untiring energy the recent scientific, educational and medical progress of the city is in great measure due. From a medical school and an unimportant college, the University of Pennsylvania under his administration developed into a great university. He was largely or chiefly instrumental in founding the University Hospital, the Pennsylvania Museum and School of Industrial Art and other institutions. He was, at the time of his death, Vice-President and the real executive of the American Philosophical Society and President of the Philadelphia Museums.

THE French Society of Hygiene will award next year fifteen prizes for the best essays on the means of improving the condition of crews of fishing boats. The essays are to be sent in before January 1st to M. M. E. Cacheux, 25, Quai Saint Michel.

WE learn from the *British Medical Journal* that the Instituto Veneto di Lettere, Scienze ed Arti has awarded the three Balbi-Valier prizes, which are of the value of £120 each, respectively, to Senator Durante, professor of surgery in the University of Rome, for his treatise on General Special Surgical Pathology and Treatment; to Professor Boscchetti for his work on 'Tremulotherapy;' and to Professor Emilio Cavazzani, lecturer on physiology and pharmacology in the University of Ferrara, for his researches on the Thermogenesis, Glycogenesis and Circulation of the Fœtus.

THE fund collected by international subscriptions for memorials to Sir John Pender has now been closed. The marble bust of Sir John Pender by Mr. E. Onslow Ford, to be placed temporarily in the Board room of the Eastern Tele-

graph Company, and the replica for University College, London, required a comparatively small part of the fund. £5,000 were devoted to endowing the Pender Electric Laboratory of University College, £1,650 for endowing scholarships in Glasgow University, and £210 for the John Pender Gold Medal of the Glasgow and West of Scotland Technical College.

THE Société Française d'Hygiène invites subscriptions for the erection of a memorial bust of the late Dr. Prosper de Pietra Santa, who was the founder and Permanent Secretary of the Society and editor of the *Journal de Hygiène*.

THE report of the Council of the British Medical Association shows that the number of members is 17,746, an increase of 791 since last year. The number of new members, 1,473, is the largest recorded in any one year since the Association was founded. The revenue of the past year amounted to £40,433. The Association has purchased during the year, for £79,000, the freehold of the property on the Strand which they have held on lease. The sum of £366 has been allotted for scientific grants and £450 for scientific scholarships. A scholarship has been founded as a memorial of the late Mr. Ernest Hart, to be called 'The Ernest Hart Memorial Scholarship for Preventive Medicine.' The scholarship, which will be of the annual value of £200, will be tenable for two years. Mr. Hart, it will be remembered, was the editor of the *British Medical Journal*, the organ of the Association.

THE annual meetings of the British Society of Chemical Industry were commenced at University College, Nottingham, on July 13th. The President, Professor Clowes, made an address, and the medal of the Society was awarded to Dr. W. H. Perkin, who in 1856 discovered aniline purple, a discovery which laid the foundation of the extensive coal-tar industry of the present time. The Society has now 3,196 members and its income last year was £4,738.

THE Latin-American Scientific Congress will next meet in 1901 at Montevideo.

THE *Revue Scientifique* has published a preliminary list of papers, some sixty in number, to be presented at the approaching meeting of the French Association for the Advancement of

Science, which will be held at Nantes from the 4th to the 11th of August. Many of the papers are of interest, although the most prominent French men of science do not seem to attend the meetings of the Association.

MR. EDWARD DODSON, of the Natural History Museum, London, has left England to join Mr. H. S. Cavendish, the African explorer, who is now at Beira.

DR. E. LEWIS STURTEVANT, widely known as an expert on scientific agriculture, in which capacity he was connected with the United States government for many years, died at Framingham, Mass., on July 30th, aged fifty-six years.

PROFESSOR JOHN CAIRD, the well-known writer on philosophical subjects, died on July 30th, aged seventy-eight years. His resignation from the principalship of the University of Glasgow was to have taken effect on August 1st.

DR. BEATTIE CROZIER'S Civil List pension of £50 has been increased to £100 in order to enable him to complete his 'History of Intellectual Development on the Lines of Modern Evolution,' the first volume of which appeared in 1897.

*Nature* states that the French Société d'Encouragement has awarded the grand prize of 12,000 francs to M. Moissan for his numerous researches in chemistry; the prize of 2,000 francs for the experimental study of the properties of metals and alloys to M. C. E. Guillaume; the prize of 1,000 francs for an investigation of albuminoids to M. Fleurent; a prize of 2,000 francs to M. Cord for his work on the agriculture and geology of the soils in the department of Lozère; an *encouragement* of 500 francs to M. Capredon for his work on metallurgical chemistry; of 500 francs to M. A. Bigot for his work on enamels; of 1,000 francs to M. Pagès for his work on the agriculture of the Cantal Department; and 500 francs to M. Mazel for his work on the agriculture of the Vivarais district.

WE learn from the London *Times* that news has been received at Cambridge of the arrival of the Cambridge Anthropological Expedition to Torres Straits at Murray Island. The expedition reached Thursday Island on April 23d.



The Hon. John Douglas, C.M.G., the Government Resident, did all in his power, personally and officially, to advance the aims of the expedition, as did also the other government officials and many others. The Hon. J. G. Byrnes, Chief Secretary, sent a cordial telegram of welcome and promise of assistance from Brisbane, on behalf of the government. After a week's delay a start was made for Murray Island in two open luggers, and owing to the unfavorable weather it took another week to traverse the 120 miles between the two islands. All the party suffered considerably from heat and exposure in the open boats. The Murray Islanders gave Dr. Haddon a very hearty welcome, bringing gifts of coconuts and bauauas as expressions of good will. They appeared to understand the main objects of the expedition. A deserted mission house, in which Dr. Haddon stayed ten years ago, was occupied as a dwelling house, and had also been converted into a temporary anthropological and psychological laboratory, photographic studio, surgery and dispensary. All the members of the expedition were in good health, and work has begun in earnest.

SIR MARTIN CONWAY has left England for Bolivia, where he intends to explore the high group of the Andes containing the peaks Illimani and Illampu. He is accompanied by the Alpine guides Antoine Mauquignaz and Louis Pellissier, who made the first ascent of Mount St. Elias, in Alaska, last year with the Duke of the Abruzzi.

At a meeting of the Zoological Society of London, on June 11th, the Secretary read a report on the additions that had been made to the Society's menagerie during the month of May, 1898, and called special attention to a young female Mountain Zebra (*Equus zebra*) and a young male Leucoryx Antelope, acquired by purchase; a young male Reindeer (*Rangifer tarandus*), presented by the Hon. M. A. Bourke; and two Black-necked Swans (*Cygnus nigricollis*), hatched in the Gardens.

It is expected that the new laboratory building of the Johns Hopkins University Medical School, adjacent to the hospital, will be ready for occupation in the autumn. It will accom-

modate the laboratories of physiology, of physiological chemistry and of pharmacology.

AN Institute of Hygiene has been opened in Buenos Ayres. The Director of the Institute is Dr. Ferruccio Mercanti.

THE buildings of the United States Fish Commission at Woods Holl were examined with a view to using them for an army hospital. Fortunately, the buildings were found unsatisfactory for this purpose, as otherwise the important work now in progress under the Fish Commission, as well as that of the Marine Biological Laboratory, would have been completely stopped for the year.

It will be remembered that the sum of \$650,000 has been appropriated by the United States government for the representation of the country at the Paris Exposition. Mr. Ferdinand Peck, the newly appointed Commissioner, has had a conference with the President, and it is said that the latter will recommend an appropriation of \$400,000 additional.

A LARGE part of the session of the British House of Commons on July 19th was devoted to the consideration of the vaccination bill founded by the government upon the recommendation of the Royal Commission. Much opposition was shown to the bill, and Mr. Balfour, on behalf of the government, appeared to favor its modification in the sense that vaccination would not be required if a parent stated that he believed it to be prejudicial to the health of his child.

THE great activity among students of our Southeastern flora has become a subject of common remark. The results of this work have been appearing in numerous articles in the botanical journals from Messrs. Small, Nash, Bicknell, Beadle, Kearney, Underwood, Earle, Pollard, Ashe and others. Much of this published work has been the result of personal investigations in the field, which speaks well for the great botanical interest attached to this flora. Several separate works on the subject have been prepared or are in course of preparation. The 'List of Alabama Fungi' by Messrs. Earle and Underwood was published by the Alabama Polytechnic Institute. Dr. Mohr's monumental work on Alabama plants will soon appear as a

government publication. We understand Dr. Small has in progress a Botany of the South-eastern United States. A new edition of Chapman's Manual has lately appeared. Outside of Curtis's well known series of Florida plants but few distributions of the plants of this region have been made, though there has been great demand for them among botanists throughout the world. One of the important functions of the lately organized Alabama Biological Survey is the collection and distribution of the plants of all orders occurring in Alabama. This work prosecuted under the auspices of the Alabama Polytechnic Institute, at Auburn, and carried on for a year and a-half without supporting funds from official sources, has already resulted in the formation of a reference herbarium of about 10,000 sheets, and an exchange herbarium of about an equal number. This exchange material contains fine series of many interesting species, varieties and forms, and is at the service of the botanical world for sale or exchange.

As has already been announced, the autumn meeting of the Iron and Steel Institute will be held in Stockholm on Friday and Saturday, August 26th and 27th. We learn from *Nature* that an interesting and varied program has been prepared by the local committee, and seven papers have been promised, two being by Swedish metallurgists. Mr. Richard Ackerman, Director-General of the Swedish Board of Trade, an honorary member of the Institute and a Bessemer gold medallist, will read a paper on the development of the Swedish iron industry, whilst Professor G. Nordenström, of the School of Mines, Stockholm, will submit a communication on the most prominent and characteristic features of Swedish iron-ore mining. Mr. C. P. Sandberg will discuss the danger of using rails of too hard a nature, whilst Professor W. C. Roberts-Austen, C.B., F.R.S., will describe the action of explosives on the tubes of steel guns. The chemical side of metallurgy will be represented by three papers. The first will be by Mr. J. E. Stead, on brittleness in steel produced by annealing; the second by Professor J. O. Arnold, of University College, Sheffield, on the micro-chemistry of cementation; whilst the subject of the third paper will

be the influence of metalloids on cast iron, by Mr. Guy R. Johnson, of Tennessee, U. S. A. An excursion of twenty days' duration will follow the meeting.

THE following appeal, which should be regarded in America as well as in Great Britain, has been sent out by the committee of the Society for the Protection of Birds, London. "The committee of the Society for the Protection of Birds are convinced that the objects of the Society would be greatly helped if the assistance of landowners, shooting tenants and farmers could be obtained, as, unless united action be soon taken, many of the country's birds, especially the rare birds of prey, will shortly become extinct. This, most people agree, will be a matter of universal regret, as well as a great loss to the avifauna of the United Kingdom. It is only through the cooperation of gentlemen possessing shooting and other rights over land that it is possible to effect any real improvement in this direction; and their assistance would, in the opinion of this Society, be best given by their not allowing keepers and other persons on the land a free hand as to what birds may be killed, which is often the case at present, but, on the contrary, by giving strict instructions as to what birds only may be destroyed, which should properly be only those birds that, from their abundance in any particular district, may do real harm. The committee also desire to draw your attention to the use of the pole trap, which ought in no case to be allowed, because, even if a landowner wished to preserve rare birds of prey, this trap could show no such discrimination. It is, besides, a most cruel instrument, because, if it is not examined regularly, any bird caught in it may hang for days in misery, and on this account this trap has been prohibited on many estates. The Society would be greatly obliged if you would kindly give these matters your careful consideration, and, if possible, give instructions in the manner indicated, or in any other way that may seem good to you. In order that there should be no misapprehension as to the objects of the Society the following extract from the rules is added: 'The attitude of the Society is strictly neutral on the question of the killing of game birds and legitimate sport of that character.'"

## UNIVERSITY AND EDUCATIONAL NEWS.

MRS. EMILY PRISCILLA EDGELL HUNT has bequeathed £5,000 to King's College School, London, for scholarships to be awarded for proficiency in practical sciences. She also bequeathed £1,000 to the benevolent fund of the Institution of Civil Engineers, and large sums to London hospitals.

SIR WILLIAM FRASER has bequeathed £35,000 and half the residue of his estate to the University of Edinburgh.

THE Edinburgh University Court has appointed to the new professorship of public health and sanitary science at Edinburgh University Dr. Charles Hunter Stewart, who for the past ten years has acted as chief assistant in the bacteriological laboratory connected with the chair of medical jurisprudence and public health in Edinburgh University.

## DISCUSSION AND CORRESPONDENCE.

## SCIENCE IN THE BUREAU OF EDUCATION.

DOUBTLESS a large number of the readers of SCIENCE have just received the first volume of the Report of the Commissioner of Education for 1896-97, and after remarking on its unusually prompt appearance have put it away unopened, to await some emergency in which its statistics may be useful. It may be desirable to call attention to the fact that this report is distinguished above its fellows by a most remarkable article on 'Recent Contributions of Biology, Sociology and Metallurgy to the Curriculum of Agricultural Colleges.' This forms Chapter 20 of the Report, pp. 923-1080. It is of the biological section that I wish to speak.

Considering that the article deals with 'recent contributions,' it is rather surprising to find the amount of space given to quotations from De Saussure and Liebig. But it is still more surprising to find that the author quotes with approval on p. 945 the statement of the former writer that "plants do not take all their mineral food out of solutions such as those which are artificially made, \* \* \* but they take them for the most part from compounds which we are unable to form, namely, out of such compounds in which these salts are chemically combined with oxygen, hydrogen, nitrogen and

carbon in humus extract, a fact that can only be revealed to us by an examination of the ashes of the plant." It would seem that the writer had never heard of water-cultures.

After giving quantitative proof (from de Saussure and Boussingault) of the absorption of CO<sub>2</sub> and the giving-off of O by green leaves, the remark follows, p. 929: "It is quite safe, then, to say that the leaf eats (so to speak) of carbon, and that indirectly it takes this from the air, though it must never be forgotten that the capital function of the leaf is, to use an expression necessitated by our ignorance, 'to elaborate' the sap. Why the leaf should act thus through a green substance it contains called chlorophyll has engaged the attention of many, but there is something about the question that stunts the growth of an hypothesis." (!)

"The root is an apparatus to absorb water. It is composed of three parts; a cap or penetrating point, a muff of fine hairs which follows close behind the cap, and finally an arm or the body proper of the root, which is at once an anchor, an alimentary canal and a pump." (p. 931.)

Apparently the Jews of the Education Bureau have no dealings with the Samaritans of the Department of Agriculture, or the writer would hardly have said that agrostology is the Gallic name for soil physics. And he might have found a zoologist to tell him that 'the substance resembling cellulose called tunicine' is not so called 'from its being found only in the mantle which covers the body of oysters and other mollusks.' He might also have been shown a specimen of growing yeast, and one of *Protococcus*, which would have kept him from evolving the 'diagrammatic sketches' of these plants on p. 971.

It is impossible to do justice to this writer without longer citations than SCIENCE probably can afford space for. I will simply mention some of the most striking passages. There is some fine confused reading in the account of the nitrogen question, on pp. 929-940, though Schloesing and Müntz, Hellriegel and Wilfarth, are quoted in some detail. The gem of the chapter is, however, the section on the life-process and instinct of the plant, and particularly the subsection on the 'development of the male cell (*i. e.*, pollen-grain) in the ovary,' from which it appears that "antecedent to the fecun-



dation there is a microbous growth which sets up interior disarrangements, \* \* \* which eventually result after fecundation in the formation of a miniature plant. The strange thing about the matter is that the little plant may, when grown up, turn out to be greatly different from either the plant from which the pollen drifted or from the plant which caught and nourished the pollen on its stigma and then received the 'being' of the pollen in its ovary." The question of the ascent of water in plants is attacked, and the author seems sceptical about the existence of root-pressure and transpiration, while the famous spiral tendency is revived in connection with the ascent of sap and phyllotaxy. Evolution, natural selection and spontaneous generation are mentioned in a way that shows that there are still dark places into which correct notions of these phrases have not penetrated. As has been indicated, quotations from good authors are interspersed, but the result is rather like that which follows a mixture of ice cream and lobster salad.

It is hard to say what object this article can be conceived to serve. The distinguished metaphysician who has been the efficient head of the bureau so long, and may he long remain there, might perhaps be able to give an answer from the depths of his philosophic lore. No plain man can. Fortunately from the method of its publication, the indigestible mass of actinic rays, earthworms, Rothamsted experiments and circumnotation—in addition to the constituents already mentioned—cannot do much harm except to the naïve folks who think that government reports are a sort of gospel.

Seriously, although scientific men are becoming accustomed to the notion that pedagogical 'experts' have a plenary inspiration which gives them the right to discuss all subjects under the sun without studying them; and although they may simply smile when a psychologist speaks of the legs of a hydra, and opposes the sarcolemma to the germ-plasm, and attributes the upward growth of a stem to heliotropism, if he has something to say that compensates for the blunders; yet it does seem that these people might at least take the trouble to submit their manuscript to some *Fachmann* before publication. And the Bureau of Educa-

tion might do well to investigate the training of its 'specialists' a little before employing them to write up scientific subjects.

UNIVERSITY OF COLORADO. JOHN GARDINER.

#### THE PSYCHOLOGY OF SUGGESTION.

TO THE EDITOR OF SCIENCE: Permit me to make a few remarks in regard to the review of my book, 'The Psychology of Suggestion' by Professor Wm. Romaine Newbold in SCIENCE for June 24, 1898.

Professor Newbold contends against the truth of my second law, that of abnormal suggestibility. He brings the phenomena of *rapport*. "In states of heightened suggestibility," he writes, "suggestibility to suggestion has no significant relation to the mode in which the suggestion is administered, but rather to the *source whence it comes*." (The italics are his own.) "Rapport," he says further on, "although not an inevitable, is perhaps one of the most constant traits of heightened suggestibility, and this Dr. Sidis' second law ignores." Now this is not true. *Rapport* is not a characteristic spontaneous trait of the advanced stages of hypnosis, it is itself due to a suggestion forced on the subconsciousness of the subject. Where the personal element is considered important, there the phenomena of *rapport* will naturally be frequent. Where, however, it is realized that hypnosis has little to do with the personality of the experimenter, *rapport* is *absolutely* absent even in the very last stages of hypnosis. Thus in none of my best subjects have I found the phenomena of *rapport*. *Rapport* had to be specially induced by most emphatic suggestions. This is simply due to the fact that in my experiments I have taken precaution to guard against all unconscious suggestions in general, and particularly against the 'personality suggestion.' The importance of the personal element, 'the source' in hypnosis is a widely spread, but an unjustified belief due, no doubt, to some lingering remnants of mesmeric theories. As a matter of fact, *rapport* is not spontaneous in hypnosis, it is induced by suggestion, and, like all other suggestions, depends on the conditions and laws of suggestibility.

Professor Newbold finds fault with my preliminary definition of suggestibility. I won-



der Professor Newbold does not see that the definition given in the first chapter is only provisional to start the work with, that the nature of suggestion and suggestibility is worked out in the course of the first part, and that the final definition is not arrived at before the end of the eleventh chapter.

A few words more before I conclude. Professor Newbold finds my physiological theory rather incorrect when confronted with Apathy's investigations. I do not find that my theory is to any extent shaken by Apathy's 'anastomosis.' Apathy's work may hold good for the nervous system of the lower invertebrates, but not of the cerebro-spinal nervous system and especially of the association areas. Apathy himself admits it. I am happy to say that the eminent pathologist, Professor Ira Van Gieson, accepts the same physiological theory, and in a special work will take up this point about Apathy and will furnish experimental data demonstrating the truth of the position taken by me in the book 'The Psychology of Suggestion.'

Professor Newbold's criticism is fair and candid, and one cannot help contrasting it with the virulent, almost personal, onslaught of those academic psychophysicists, especially of the Wundtian fold, who lack and neglect all knowledge of mental pathology and who attack bitterly any one who has the courage to proclaim openly the poor and sterile state, the trivial nature of the scholastic laboratory science of normal 'student psychology.'

BORIS SIDIS.  
PATHOLOGICAL INSTITUTE OF THE  
NEW YORK STATE HOSPITALS, NEW YORK.

#### CELLULOID FILMS.

TO THE EDITOR OF SCIENCE: My own experiments and sad experiences in the use of celluloid 'cut films' instead of glass plates for photographic purposes on long expeditions prompt me to write a warning to those who will read the note quoted in SCIENCE, July 22, 1898, page 106. If the advice given by Mr. Stillman were followed by scientists without further test I greatly fear that their return from a six months' expedition with numerous undeveloped 'films' safely stowed away for development at leisure would be made less enjoyable after a few hours in the dark room.

Two years ago I made trial of some fresh films and thought them so superior to glass because of their lightness that I adopted them for use on a visit by bicycle to the astronomical observatories of Europe. I could not find ten dozen in stock in New York without taking some that were three months old. I was in Europe only three months, and during that time carried those films and a camera with other baggage on my bicycle for two thousand miles, on hot days huoyed through the 'slough of despond' by the expectation of having at least one hundred fine photographs of observatories and scenery. The camera was a familiar one, and I had had long experience in photography in America and in South and Central Africa with glass plates which had always proved successful. But, alas! when I returned to the States and at once proceeded to develop the films I could find only the faintest traces of the scenes which ought to have been there. There was every indication that the acids in the celluloid had destroyed the sensitiveness of the emulsion either before or after exposure. Since then experiments on 'films' of various ages and the questioning of professional photographers who have developed many thousands of these 'films' have confirmed my belief that *as a rule* they may be regarded as practically worthless after they had been made a year, and are very unreliable after six months. I mean by 'unreliable' that it is impossible to predict by the action of one plate what the time of exposure on another plate of the same emulsion ought to be.

Hence I conclude that one should be very cautious in adopting the suggestions of Mr. W. J. Stillman, from whom you quote, if the expedition is to last more than six months from the time when the plates were made; and in every case I should prefer to get fresh films every month and develop them as they are exposed.

HERMAN S. DAVIS.  
COLUMBIA UNIVERSITY, July 22, 1898.

#### SCIENTIFIC LITERATURE.

*Au Pays des ba-Rotsi.* By ALFRED BERTRAND.  
Paris, France, Hachette et Cie. 4to. Pp. 333  
and 10. 104 illustrations.

This volume, prepared in the handsome style of the famous French publishing house from

which it has emanated, has a great many things in its favor. The illustrations are particularly good.

It deals with a country whose northern boundary, as yet unknown, probably reaches the watershed lying between the Congo and the Zambesi. On the east it is limited by the Kafukwe river and on the west by an indefinite boundary at about 20° east of Greenwich. On the south it is bounded by the Zambesi and the Linyanti. The extent of the country, therefore, might be defined by stating that it lies between the 12°th and the 18°th south latitude, and between the 20°th and 29°th in east longitude. The essence of the book, however, is not in the three hundred pages of the text; but in the twenty pages of the two appendices.

The first part of the volume deals with a visit to the diamond mines at Kimberley. It is interesting to note that, while there were no houses upon the site of this city in 1870, Kimberley now contains nearly twenty thousand inhabitants and its daily product reaches the sum of \$50,000. The railroad from the Cape extends through this city to Mafeking. It is only at this latter point that the signs of civilization begin to disappear. Here it is that the caravans start for the interior.

Some of the comments of our writer upon the phases of life through which he passes are interesting, because they indicate the watchful French mind, wide open to new impressions. He seems to admire immensely the 'Bouledogues' taken along as guardians of the camp. Then come a series of observations upon the experiences of the caravan in its trip to the northward, along the border of the desert of Kalahari. At Palapye he meets King Kahma, the disciple of Moffat and Livingston, who apparently is a model monarch. It appears that there is at least one place where the sale of alcoholic beverages can be prevented by regal enactments, and this African king seems to be more successful than some of his white brethren in the prosecution of this work.

The author comments upon the supervision of these colonies by Great Britain with great satisfaction, as he finds that they are managed with much good sense and are practical because they are adapted to the conditions.

It is hardly necessary to devote any space to the consideration of the details of the trip to the Zambesi, with which nearly one-third of the volume is taken up. At length, however, the Machile river is reached. This stream is a branch of the Zambesi, and, though known before, has only been tentatively placed upon the maps. The author can be interesting, but a great deal of the story suggests nothing but lists of mud settlements, terribly hot days, bad water and various subsidiary rhapsodies upon each new dish of game which seem to produce a novel sensation upon his digestion. He seems to have paid a profitable visit to King Lewanika, who gave him a great deal of information with reference to the country he was exploring; but much of the information given is still a secret between himself and the king, as the description given of this new region is very scanty, indeed.

The author visits the celebrated Victoria Falls of the Zambesi before starting out upon his return trip, and his description of the trip down the river in canoes is well done, in spite of the fact that we become tired at length of the groans of the hippopotami and the yawns of the crocodiles.

His account of the beauty and grandeur of the famous falls is well worth reading, though it would seem that geology and geography rather suffer in his hands from neglect. On his return journey the author has a bad attack of fever in the 'thirst' desert, where he is nearly prostrated and has some very sad experiences. Eventually, however, he reaches Pretoria. From this city he visits the gold mines of Johannesburg, of which a careful description is given. He happened to be in the city at the time of the Jameson raid in January, 1896, and his experiences as a prisoner in the city at that time are well given. The trip occupied nearly a whole year, from March 23, 1895, to March 2, 1896.

The author was fortunate in obtaining from M. Jalla the records of ten years of temperature observation, from which the following notes are taken:

Hot season.

+ 47° C. in shade 2 to 4 p. m.

+ 20° to 22° C. at night.

End of October.

Cold season.

+ 24° to 25° C. during day.

+ 6° to 10° C. during night.

May, June, July.

In the hot season the thermometer in the sun reaches 60° C., and the author comments upon the necessity of taking the thermometer under shelter to prevent its bursting.

The country generally is considered very unhealthy, as even the natives suffer with the fever.

In the first appendix notes are given upon the fragmentary history of the people of this region, which is about equal in area to that of France. The habits and customs of the people are briefly discussed. The earlier type of punishments for disobedience or neglect are of the most cruel character for even the slightest offenses, as, for example, when one of King Lewanika's rowers became tired he was deliberately thrown overboard to keep company with the crocodiles.

The religious ideas of this section of the country are more advanced than in any other portion of Africa. They have a modified form of ancestral worship, without idols or fetiches. They have both male and female supreme beings, the former symbolized by the sun and known as Nyambe, while the latter is represented by the moon. She was the mother of the animals, and finally of man. Eventually Nyambe and the men of the world came into disagreement, and while he showed his power by resuscitating the animals which men killed, man, however, became so very intelligent that Nyambe was forced to escape to the heavens by means of a spider's web and has been invisible since that time.

They believe in metempsychosis and during their life choose the animal form in which they prefer to return to the earth. They initiate themselves by eating worms from the decayed bodies of their chosen animal. They will then, upon any festal occasion, act the part of these animals by imitating their motions and their cries.

They are very superstitious, believing in charms of all sorts, and they attribute the better shooting-powers of the white man to be due to the possession of an amulet of which they are ignorant.

These natives are an industrious people and work metals very well, and although their

methods are of the most primitive sort they produce good spears, axes and knives. Under proper guidance they could easily develop along mechanical lines, and missionaries who have lived with them many years wish very much to start an industrial school with this in view.

The resources of the country are little known. Iron is known to exist, but the main value of the region, so far as seen, is in its woods, many of which would be valuable even for transportation. Animals are still found in great numbers and variety, although the most valuable of them all, the elephant, is said to be disappearing rapidly. The insects are likewise numerous and are said to be a terrible pest.

The words of the missionary Coillard concerning this part of the world, where the waves of immigration are dashing their foam well in towards the center of the continent, are significant:

"Listen to the native songs in a minor key; they are in reality but groans. Hear them tell you that their heart is black, *i. e.*, that it is full of sadness, yes, black as their skin, and you will realize that from the cradle to the grave they carry through life the symbol and the livery of sorrow. If these races are to have a future, as seems certain, what will it be? It seems that it will undoubtedly be dependent upon the character which the mental, moral and physical powers of the white race will choose to give it."

The second appendix gives a summary of the report made by Captain A. Saint-Hill Gibbons, Percy C. Reid and the author to the Royal Geographical Society on January 4, 1897 (see *Geographical Journal*, Vol. IX., No. 2).

WILLIAM LIBBEY.

*The Art of Taxidermy.* By JOHN ROWLEY, Chief of the Department of Taxidermy in the American Museum of Natural History, New York City. New York, D. Appleton & Co. 1898. Pp. xii + 244. 20 plates and 59 text figures.

This book is a good exemplification of the adage that there is always room at the top, for while scores of books have been written on the art of taxidermy, and the best of them within the last decade, this is none the less indispen-

sable to any one who wishes to keep up to date. The eight chapters into which the work is divided are devoted to collecting; tools and materials; casting; birds; mammals; fish, reptiles and crustaceans; skeletons; and the reproduction of foliage for groups. There is in addition an appendix giving the addresses of reliable firms from whom tools and materials may be purchased. All these contain important information and all are based on personal experience, and while naturally in some cases much of the ground has already been covered, yet it is surprising to see how much there is not only new, but good. The most important chapter is that relating to the mounting of mammals, and particularly of large mammals, ability to do this well being the crucial test of a taxidermist. Time was when they were stuffed in the most literal sense of the word, but the last twenty years have wrought a great change, and it no longer suffices to simply fill a big mammal with straw; he must be fitted to a nicety over a manikin modeled into shape with the greatest care. Mr. Rowley's special device is the *papier maché* manikin made on wire cloth, and this he claims when the skin is properly glued on will stand the test of time, a claim that is borne out by the appearance of specimens mounted in this manner, although we can be more certain of the result ten years from now. Only those who have had a practical acquaintance with the mounting of large mammals and watched their behavior in steam-heated halls can appreciate the desirability of some process that will give freedom of manipulation and prove enduring, for, like Mr. Rowley, we have seen the wreck and ruin of some beautiful specimens that simply went to pieces through the splitting of the skin, brought about by atmospheric changes. It might, however, have been well to have briefly described the manikin of excelsior, giving it as an alternative, since in the majority of cases it will do very well, and one without experience might hesitate before attempting the somewhat more difficult *papier maché* method.

Another valuable chapter is that devoted to the reproduction of foliage and flowers, for while this subject is well treated by Montagu Brown, yet he unfortunately omits a most important piece of information which Mr. Rowley

supplies, namely, how to make the 'fabric' which is the basis of it all. While this reproduction may not be taxidermy, it has yet become an important matter since the modern museum calls, or should call, for the exhibition of groups showing animals amid their natural surroundings, and unless these surroundings are duplicated with great skill the result is discouraging.

The chapter on skeletons, though brief, is very good, although we suspect it would not occur to any one not familiar with the manner in which things are done at the American Museum to suggest the use of porcelain bath tubs for macerating purposes.

In regard to fishes Mr. Rowley well says that in most cases they are better reproduced by casting than by skinning and mounting the skin, and this is emphatically true of the larger species which seem to delight in setting at naught all efforts to mount them.

Here and there one could wish for just a little more information than is given, but as one of the aims of the book was to supply a good manual at a moderate price, conciseness was necessary and the book can be recommended not only to those who wish to be, but to those who already are taxidermists.

F. A. L.

*Water and Public Health.* By JAMES H. FUERTES. New York, John Wiley & Sons. Pp. 75. Price, \$1.50.

The method adopted by Mr. Fuertes, of stating many of his statistics in graphic form, is very acceptable to the general reader. The eye will grasp the meaning of a chart, and the mental picture of the same will be retained, while groups of simple figures make but a small impression.

An excellent point, insisted on by the author and forcibly illustrated, is that Europe is far ahead of us in the matter of carefully purifying such public waters as are suspected of being contaminated, and he further shows that America cannot expect immunity from epidemic disease should she continue the use of polluted supplies. The book is a valuable contribution to the literature of Water Supply.

W. P. MASON.



*The Arrangement of Atoms in Space.* By J. H. VAN'T HOFF. Second, Revised and Enlarged Edition. With a Preface by JOHANNES WISLECENUS, and an Appendix, Stereochemistry among Inorganic Substances, by ALFRED WERNER. Translated and Edited by ARNOLD EILOART. London, New York and Bombay, Longmans, Green & Co. Pp. xi + 211.

In the earlier development of theories with regard to the structure of chemical compounds, chemists were very careful to state that the formulæ used were not intended to represent, at all, the actual geometrical positions of the atoms within the molecules. It was with a great deal of scepticism, therefore, that the chemical world received the first attempts at a logical discussion of the arrangement of atoms in space. These attempts were made by van't Hoff and by Le Bel, independently, in 1874. For many years the theory made little headway and, at most, received some notice in connection with the discussion of optically active substances. Gradually, however, the theory proved so useful that the present situation is well summarized in the following words of Professor Wislecenus from his preface to this book:

"The old opposition to the principle has almost died out; where it still lives it is directed against the ultimate basis—against the Atomic Hypothesis itself—and does not deny that the doctrine of atomic arrangement in three dimensions is a logical and necessary stage, perhaps the final stage, in the chemical theory of atoms. \* \* \* It has already effected to the full all that can be effected by any theory; for it has brought into organic connection with the fundamental theories of chemistry facts which were before incomprehensible and apparently isolated, and also enabled us to explain them from these theories in the simplest way. By propounding to us new problems, the new theory has stimulated empirical investigations on all sides; it has caused a vast accumulation of facts, has led to the discovery of new methods of observation, has become amenable to the tests of experiment, and has at the same time started in our science a movement full of significance—in a certain sense, indeed, a new epoch."

The present work is a new and thoroughly revised edition of van't Hoff's well-known book. It is especially satisfactory in its discussion of stereoisomerism in its relation to optical activity. The consideration of ethylene derivatives and of ring compounds is also sufficiently full, while the concise treatment of the stereochemistry of nitrogen compounds accords well with the present rather unsatisfactory conditions of the topic. The brief statement by Alfred Werner of his views upon the stereoisomerism of certain inorganic compounds is an important and valuable addition.

The present book is noteworthy for the manner in which the fundamental conception is reduced to the simplest possible expression. All hypotheses which are not absolutely essential are omitted. In this respect the book is in marked contrast with that of Auwers on the same subject.

In a few cases, and especially for camphor and atropine and their derivatives, structural formulæ are given which are, to say the least, very improbable, if not entirely impossible, according to our present knowledge. While questions of optical activity are undoubtedly of great importance in the discussion of possible formulæ for these compounds, it seems unfortunate that such doubtful formulæ should have been used in the consideration of the fundamental principles of asymmetry as connected with optical activity.

The work of translation has been well done, and the translator, who is an authority on the subject, has added several important notes of his own.

W. A. NOYES.

*Laboratory Experiments on the Class Reactions and Identification of Organic Substances.* By ARTHUR A. NOYES and SAMUEL P. MULLIKEN. Second, Thoroughly Revised Edition. Easton, Pa., Chemical Publishing Co. Pp. 28. Price, 50 cents.

This little book may be considered as the elements of qualitative analysis for organic compounds. Because of the enormous number of these compounds the subject is not susceptible of any such set mechanical treatment as is usually given to inorganic qualitative analysis. For this reason it is all the more useful for the purpose of developing thoughtfulness and

originality on the part of the student. The work is intended to supplement the instruction in organic preparations, which has been found by the authors to "fail, to a surprising extent in the case of most students, to give a knowledge of the important characteristics of the various classes of organic compounds, and, therefore, of the fundamental principles of the science." The selection of reactions and the method of treatment are excellent, and the book will prove a very useful one. The number of reactions might, of course, be easily extended; especially is it desirable to include Liebermann's reaction for secondary amines and the general reactions for vegetable alkaloids. It would also be an advantage if the names by which some of the reactions are constantly known to chemists were given, and an occasional reference to the literature would be very useful.

W. A. NOYES.

#### SCIENTIFIC JOURNALS.

*American Chemical Journal*, July: 'A Reduction of Permanganic Acid by Manganese Peroxide.' By H. N. MORSE and C. L. REESE. The relative action of manganese peroxide and hydrogen in causing the reduction of potassium permanganate has been studied and the results compared with those obtained by Meyer and Von Recklinghausen. 'The Atomic Weight of Cadmium.' By H. N. MORSE and H. R. ARBUCKLE. The atomic weight has been redetermined and a correction introduced for the gas retained by the oxide. The mean corrected value is 112.377. 'A Table of Atomic Weights.' By T. W. RICHARDS. This table has been compiled from a comparison of the best results obtained in atomic weight work, the probable chemical accuracy of the processes being the criterion. 'Researches on the Cyclo Amides:  $\alpha$ -Ketobenzomorpholine and  $\alpha$ -Benzparaoxazine Derivatives.' By H. L. WHEELER and B. BARNES. 'The Action of Amines on Acylimidoesters: Acyl Amidines.' By H. L. WHEELER and P. T. WALDEN. 'On a New Form of Water Blast.' By B. B. BOLTWOOD. The author has devised a form which gives a high efficiency with a small amount of water. 'On the Periodic System and the Properties of Inorganic

Compounds.' By J. LOCKE. The author discusses the Periodic System and shows that the usual arrangement, which is very satisfactory when we only consider the behavior of the elements themselves, is very unsatisfactory when we compare the properties of the compounds of these elements. 'The Action of Sulphur upon Metallic Sodium.' By J. LOCKE and A. AUSTRILL. This investigation shows that the monosulphide cannot be formed by direct combination at temperatures below 220°. 'On Some Compounds of Trivalent Vanadium.' By J. LOCKE and G. H. EDWARDS. 'The Conductivity of Aqueous Solutions of Praseodymium and of Neodymium Sulphates.' By H. C. JONES and H. M. REESE. This number also contains a note on the preparation of Liquid Hydrogen, which was obtained by Professor Dewar, who also liquefied helium by introducing a tube of the gas into the liquid hydrogen.

J. ELLIOTT GILPIN.

*The American Naturalist* for June opens with an article on the fresh-water biological stations of America, by Dr. Charles A. Kofoid. The relative advantages of marine and fresh-water stations are commented on, and a description is given of the Lake Laboratory of the Ohio State University, prepared by the late Professor D. S. Kellicott, of the Biological Station of the Indiana University by Professor Carl Eigenmann, and of the Illinois Biological Station. Professor H. C. Bumpus contributes an article on the identification of fishes artificially hatched, in which he makes an interesting application of the statistical method of representing variations. The series of papers on the wings of insects by Professor Comstock and Dr. Needham is continued, and Dr. V. Sterki writes on the classification of *Ciliate Infusoria*.

#### NEW BOOKS.

*Plant Life considered with Special Reference to Form and Function.* CHARLES R. BARNES. New York, Henry Holt & Co. 1898. Pp. x + 428.

*A Brief Course in Qualitative Analysis.* ERNEST A. CONGDON. New York, Henry Holt & Co. 1898. Pp. iv + 62.

# SCIENCE

EDITORIAL COMMITTEE: S. NEWCOMB, Mathematics; R. S. WOODWARD, Mechanics; E. C. PICKERING, Astronomy; T. C. MENDENHALL, Physics; R. H. THURSTON, Engineering; IRA REMSEN, Chemistry; J. LE CONTE, Geology; W. M. DAVIS, Physiography; O. C. MARSH, Paleontology; W. K. BROOKS, C. HART MERRIAM, Zoology; S. H. SCUDDEE, Entomology; C. E. BESSEY, N. L. BRITTON, Botany; HENRY F. OSBORN, General Biology; C. S. MINOT, Embryology, Histology; H. P. BOWDITCH, Physiology; J. S. BILLINGS, Hygiene; J. MCKEEN CATTELL, Psychology; DANIEL G. BRINTON, J. W. POWELL, Anthropology.

FRIDAY, AUGUST 12, 1898.

## CONTENTS:

<i>Note on the Age of Basil Valentine</i> : C. S. PIERCE.....	169
<i>Studies from the Zoological Laboratory of Harvard University</i> : PROFESSOR E. L. MARK.....	176
<i>Raised Shore-lines on Cape Maysi, Cuba</i> : OSCAR H. HERSHEY.....	179
<i>Current Notes on Anthropology</i> :— <i>Archive of the Science of Religion; Archaeology of Corsica; The Races of Europe</i> : PROFESSOR D. G. BRINTON.....	180
<i>Notes on Inorganic Chemistry</i> : J. L. H.....	181
<i>Scientific Notes and News</i> :— <i>The Chicago Academy of Sciences; General</i> .....	182
<i>University and Educational News</i> .....	185
<i>Discussion and Correspondence</i> :— <i>Stability in Generic Nomenclature</i> : O. F. COOK.....	186
<i>Scientific Literature</i> :— <i>Some recent Works on Mechanics</i> : R. S. W. Britton and Brown's <i>Illustrated Flora of the Northern United States</i> : PROFESSOR CHARLES E. BESSEY.....	190
<i>Scientific Journals</i> .....	195
<i>Societies and Academies</i> :— <i>Engelmann Botanical Club</i> : J. B. S. NORTON. <i>Academy of Natural Sciences of Philadelphia</i> : DR. EDW. J. NOLAN.....	196
<i>New Books</i> .....	196

## NOTE ON THE AGE OF BASIL VALENTINE.

BASIL VALENTINE is usually reckoned as the earliest of the scientific chemists and a great light of human culture.\* He is supposed to have lived nearly a hundred years before Paracelsus, or at some time in the 15th century. One of the works which bears his name certainly embodies a tolerably correct conception of the behavior of antimony. Popular writers erroneously attribute to him the discovery and the name of that metal,† together with some of the most elementary and ancient operations of the chemist. But Hermann Kopp, the least unsatisfactory of the historians of Western alchemy,‡ has emphasized certain doubts

\* Thus, one historian, Schmieder, opens his chapter on Valentine with the words: "Ein Nordlicht lodert in farbigen Strahlen an Deutschlands Horizont empor."

† Even accepting the works attributed to him as authentic, it remains true that antimony had been used in type-founding before Basil Valentine's book on that metal was written. Berthelot finds the name applied to the same metal by Greek alchemists, to say nothing of its occurrence in the same sense in the encyclopedia of Vincentius Bellovacensis.

‡ Berthelot confines himself to Egyptian, Greek and Arabian authors. The work of Dr. Latz, himself a 19th century alchemist, affords some insight into the matter of alchemy. Kopp's book is of great value, although he does not pretend to have penetrated deep below the surface. Hoefer's history never had a high critical value. Schmieder and Gmelin are quite superseded. In his earlier *Beiträge* Kopp disbelieves in a real 15th Century Basil Valentine. In his *Geschichte der Alchemie* he admits the existence of such a chemist.



concerning Valentine which it is the purpose of this note to resolve.

This personage was never heard of until, in 1599, Johann Thölde published, as editor, the first of six treatises in the German language which he successively gave to the public as having been written by 'Basilius Valentinus, Benedictine monk.' The last of these, published, according to Kopp, in 1604, and entitled *Triumph-Wagen des Antimonii*, is the one upon which the renown of Valentine exclusively rests. All are works of alchemy, a doctrine that, at the time of their publication, had for generations been a mark of derision.\* I have only seen four of them, the *Triumph-Wagen*, the *Welt in Kleinen*, the *Grosse Stein der uhr-alten Weisen*, and the treatise *Von natürlichen und übernatürlichen Dingen*.† The *Triumph-Wagen* is the only one I have carefully studied.

I begin with a logical consideration. It is very important to bear in mind, at the outset, that the all but universal custom of alchemists was to publish their writings as having been handed down from remote ages. This custom had been traditional since the remotest periods of Egyptian alchemy. Besides, there was an obvious reason for it. Announce to the world that a gold dollar costs you but a dime, and either you are poor, when your neighbors will laugh at

\* Thus, Gulielmus Gratarolus (an Italian physician, inclined to Lutherism, b. 1516, d. 1568), who in 1561 published a collection of alchemical writings in two volumes folio, concludes an introductory dialogue on the subject with these words: 'Sapientia autem præmia divitiis esse \* \* \* nemo unquam sanæ mentis fatebitur \* \* \* Necessarium est, ut priusquam capere incipiant, extremum infortunium, et ipsa Ἀτῆ, illo miserando casu fædoque interritu deiciat atque pessundet.'

† I only know these in the edition of 1740, which professes (for these treatises) to follow the text of Thölde, except that it corrects obvious misprints and adds some plates to those illustrating the *Grosse Stein*. I have seen these same figures attached to a different text attributed to Valentine and bearing the date 1625.

you, or your circumstances are comfortable, when you will be besieged by importunities as well as exposed to the resentment of those who dread your overturning the existing *status* of property. So it would be even in our well-governed age; how much more in wilder states of society! For this reason, although for books in general the *prima facie* presumption that they were written by the persons whom they name as their authors is even stronger than critics are apt to think, yet for alchemical books this initial presumption is reversed. If a book of alchemy professes to be written by an adept, that is, by one who can make gold, there is a probability amounting almost to certainty that its real authorship is concealed, and if it professes to be written long before its publication the presumption, founded on the general practice of such writers, is that the real author is he who has given it to the world. That is the theory which logic demands should first be tried.

Now these books of Valentine state repeatedly that the author has achieved the 'great work' of the alchemists. Hence, until facts drive us from the position, we ought to begin by presuming that 'Basilius Valentinus' was the *nom de plume* of Thölde. Nevertheless, in order to satisfy those who may not assent to this view, I shall begin by showing that it is impossible to believe the averments of the books themselves in regard to their authorship.

First of all, a slight sketch of the contents of the four treatises above named may be interesting. The tract '*Von der Welt in Kleinen*,' or, as it is entitled in the edition I use, '*De Microcosmo, oder von der kleinen Welt des menschlichen Leibes*,' fills but 15 small octavo pages. The author opens with an attempted explanation of the creation of the universe, or Macrocosm, and of man, or the Microcosm. The matter out of which the world was formed was nothing. The



matter and form in the first stage of creation, which he calls 'die Form oder *Materia*,' was earth and water. Creation consisted in separating these two; it was a work of chemical analysis. The principal result is the earth, and the essence of the earth is *salt*. The salt of man is his body. As the second step of creation, mobility was requisite. The warm air breathed by the Creator upon the earth rendered the latter pregnant, and *sulphur* was brought forth, which is an intangible, conscious spirit, imparting, through its inflammability, warmth and motion. The sulphur of man is his soul. All animals and plants have souls. Next, the earth became again pregnant, this time of its moisture; and *mercury* was brought forth, being an invisible and intangible shape identical with the power of imagination from which results all cognition. In the microcosm, owing to its volatility, this mercury resides chiefly in the upper parts. It is the invisible spirit of the human body, plainly identical with the archæus of Paracelsus. These three things, salt, sulphur and mercury, or body, soul and archæus, are the three constituents of Macrocosm and of Microcosm alike—the *tria principia*. These three constituents must exist in all animals, vegetables and minerals. A man, for example, feeds upon beef, which nourishes body, soul and archæus. The nutrition takes place by putrefaction in the stomach. Now putrefaction is nothing but chemical decomposition. This decomposition being effected, assimilation in due proportions takes place. Thus, nourishment for body, soul and archæus must exist in the beef; that is, the salt, the mercury and the sulphur must all be contained in it. The ox, in its turn, feeds upon vegetables; and by the same argument the *tria principia* must all be present in these vegetables. Finally, the plants derive their nutriment from minerals; and thus by necessity all three constituents

must be contained in the minerals. The remainder of the *brochure* seems intended to apply the doctrine of the universal presence of the *tria principia* to the tracing out of a chemical physiology of the action of various foods and medicines upon the human body. All this is diffused through a vehicle of bombastic verbiage. Curious little theories abound, such as that 'the liver must have air, else it could not laugh;' that 'the salt-spirit has its chief seat in the bladder;' 'like must be expelled by like;' 'the seven metals are fundamentally but one substance,' all of which are Paracelsian doctrines.

Following this tract, I find, in the edition I use, a sort of mountebank's speech concerning two universal medicines, called Phalaia and Asa, the former to be administered inwardly, the latter for external application. Then come some score of odes on such poetic themes as copper, vitriol, sal amoniac, tartar, etc.

In the treatise *Von dem grossen Stein der uhr-alten Weisen* we trace the same principles. The following sentence is a fair specimen of the book at its clearest: "Nimm ein Stück des allerbesten feinen Goldes, und zerlege dasselbige durch die Mittel, so die Natur dem kunst-liebenden Menschen nachgelassen, von einander, wie ein Artzt des Menschen Körper zerlegt, und dadurch den innerlichen Leib des Menschen erfahren will, und mache aus denen Gold zurück, was es zuvor gewesen ist, so wirstu finden den Saamen, den Anfang, das Mittel und das Ende, woraus unser Gold und sein Weib gemacht worden, nemlich aus einem durchdringenden *subtilen Spiritu*, auch einer reinen zarten und unbefleckten Seele, und einem *Astralischen* Saltze und Balsam, welches nach ihrer Vereinigung anders nicht ist, den *Mercurialischer Liquor*, dasselbige Wasser ward zu seinem eigenen Gott *Mercurio* in der Schule geführt, der *examinierte* das Wasser, und da ers recht und ohne falsch befand, da machte

er Freundschaft zu ihm, und nahm das Wasser zu der Ehe, und ward aus ihnen beyden ein unverbrennlich Oel, denn der *Mercurius* ward also stolz, dass er sich selbst nicht mehr kannte, er warf seine Adlers-Flügel von sich hinweg, und verschlang selbst den glatten Schwantz des Drachen, und bote dem *Marti* an zu kämpfen, da fordert *Mars* seine Ritterschaft zusammen, und verschuf, dass man *Mercurium* musste gefangen nehmen, und ward ihm *Vulcanus* zu einem Stockmeister verordnet, also lange biss er vom weiblichen Geschlechte wiederum erlöset würde." I cannot help fancying that I am able to detect here a certain lack of scientific precision and perspicuity. There are books which undertake to explain how to translate that sort of lingo, telling us, for example, "aqua quandoque vocatur lapis spiritus quintæ essentiæ, quandoque vocatur terra, quandoque lapis." Probably by the aid of such a key the chemical processes of this treatise could be conjectured. I have not undertaken the task, being assured, by similar experiences, that I should only find vague hints of nonsensical notions. Upon a long frothy disquisition follow twelve chapters entitled Keys. Each of them is furnished with an emblematic picture.

The treatise *Von den natürlichen und über-natürlichen Dingen* is written in a somewhat plainer style. After repeating the doctrine of the *tria principia*, it enters upon discussions concerning biblical miracles, the doctrine of signatures, spirits, sirens, succubæ, etc. Chapter the second treats of the first 'Tinctur-Wurzel' of the metals, which, we are told, 'is a supernatural, flying, fiery spirit, which keeps itself in the air, and naturally seeks its habitation in the ground and in water.' The remaining seven chapters treat in cryptical style of the methods of dissolving the seven metals.

The *Triumph-Wagen des Antimonii* contains,

embedded in vast masses of speechifying, about thirty plainly described chemical preparations. Of these, seventeen are genuine descriptions of experiments by a skillful chemist, and are distinguished from the few perspicuous chemical directions that are to be found in Raymund Lully, in Arnold de Villanova and other medieval alchemists by the far higher grade of chemical knowledge which they evince. The remaining experiments seem to me to be conjectures never put to the test. Without such an element of fancy the theory of a medieval origin for the book would be almost absolutely negatived; from its presence nothing at all can be inferred.

The German of all four works seems to me later than Luther's Bible. Upon this matter I must speak with diffidence, however; but I leave it to the reader to compare the specimen above given with any page of Paracelsus and say which is the more modern. I cannot see how there can be room for two opinions.

The author is, in the text of each treatise named, as 'Frater Basilius Valentinus, Benedictiner Ordens.' The first three works contain little concerning his personality or age. Yet the author's preface to the *Grosse Stein* tells us that, 'da mir menschlichen Furcht zu Handen stieß,' he was led to religious reflections. He joined the Benedictines, and after he had been a monk for a good while (nun eine Zeitlange) he determined to devote his leisure hours 'die Natur von einander zu legen,' and to considering what earthly natures he should find the highest. He diligently studied many books which he found in the monastery, written by wise masters who had investigated the natures. Subsequently, in the desire to cure a sick brother, he took up the distillation of herbs, and this investigation occupied him for six years. At the end of that time he began to extend his chemical studies, and gradually went on from one thing to another.

Finally, he came across a mineral (doubtless antimony) by the study of which he was led to make a medicine which restored that sick brother to perfect health, so that he lived for a *long time* thereafter (dann er lebte noch lange hernach). It was still later in Basil's life that he became acquainted with the matters in the treatise on the *Grosse Stein*. If the 'Zeitlange' after he became a monk and before he began to study was *one year*; if the diligent study of many books on the natures occupied *two years*; if after his *six years'* work in distillation he performed a hundred operations in mineral chemistry, each of which in his style of procedure would take about two months on an average, so that he was occupied in this way *eight years*; if the long life after restoration to health of that brother who had been ill for at least fifteen years occupied *ten years*, and if the interval between the writing of the *Grosse Stein* and the more advanced and certainly later *Triumph-Wagen* was *three years*, we have a total of 30 years between his entering the Benedictine order and his writing the *Triumph-Wagen*. At this time he was living in the monastery. When, therefore, in the *Triumph-Wagen* he speaks of having early in life made a voyage to England, that must have been thirty years or more previously. We shall see presently the bearing of this calculation.

The *Triumph-Wagen* contains more than one indication from which to infer the age of the author. It also, by the way, informs us that he lived 'oberhalb Rheins,' that is, in the Upper Rheingau, or, say, somewhere south of and not very far from Mainz. The author in the *Triumph-Wagen*, no less than three times, speaks of the desirability of economizing parchment. Now, it would have been an unusual extravagance for a man in the 15th century to write chemical treatises on parchment. Certainly, if economy were any object, paper was easily procured. And, indeed, in Chapter III. of his

earlier treatise On Natural and Supernatural Things, he himself affords the quite superfluous testimony that in his time paper mills abounded. He is always and everywhere recommending 'grobe Papier' for filters. Either, then, the talk about the necessity of abridging his book in order to economize parchment was inserted in order to impart a medieval trait, or else the *Triumph-Wagen* cannot possibly have been written later than 1460 or 1470.

Just as this indication of a date occurs thrice, so there is another which is dragged in by the head and shoulders no less than seven times in the book. It is a reference to a certain disease as having recently appeared which at the time of Thölde's publication was generally supposed to have made its first appearance in 1493. Were these seven references inserted in order to create a belief in the priority of the book to Paracelsus, or was the book really written when that disease was something new?

The name which Basil Valentine gives to this disease is very suspicious. In Germany in the 15th century it was commonly called 'die wilde Wertzen;\*' but it had various other designations. Valentine, however, uses none of these. Here are his expressions:

"Die neue unbekante Krankheit so in jetzigen Krieg-Zügen in diese Lande eingeführet worden durch die Gallier."

"Die neue Franzosen-Krankheit."

"Die Franzosen."

"Die Franzosen-Sucht."

"Die neue Krankheit des Kriegs-Leute in diesen Zeit."

"Die neue Kriegs-Sucht."

"Die Krankheit der Gallier neulich auf uns geerbet."

It is doubtful whether the malady was brought to Germany from France or from Naples. Trithemius, a contemporary Ger-

\* Proksch, Geschichte des venerischen Krankheiten, 1895.



man abbot, says it came both ways.\* It was much later, during the 16th century, that the theory of a French origin became generally accepted as certain.

But passing by this difficulty, and continuing to accept the seven passages as *bona fides*, to what date do they point? Johannes Salicetus, whose work on this pestilence was printed in 1501, says that it had prevailed in Germany since 1457.† The records of a monastery at Mainz (near which Valentine must have lived) show that a chorister there was attacked by it in 1472,‡ so that it was already spreading beyond the army; and so famous a physician as Basil Valentine boasts of being would certainly have heard of that case. But Valentine says it was brought to Germany, not by German soldiers coming home, but by French soldiers in the 'present war.' I do not know what war that could have been, unless it was the struggle of Charles the Bold, not far from the Rheingau, which lasted from 1464 to 1477. Thus, if the book is genuine at all, we find again that it must have been written about 1470.

There is a third indication of the date. Namely, the author tells us that in his youth he learned in England the process of making beer with hops, which process he describes. He adds that in Germany this method is not very common, thus implying that it was very common in England thirty years or more before he wrote the *Triumph-Wagen*, or, say, about 1430 or 1440. Unfortunately, all authorities agree that hop-brewed beer was not introduced into England till very long after. I find the date 1551 given as that of the first planting a hop-garden in England. Men could not have had much experience of hop-brewed beer as long as hops were considered to be an adulteration. Now, under Henry VIII.

penalties were imposed against that mode of brewing. Basil, however, speaks of it as a great improvement, and never hints at any condemnation of it. This is a difficulty that it seems impossible to avoid.

There are others. The author was a far more accomplished chemist than any other of the 15th century or of the early part of the 16th. How can it be that such a man lived a long life and never imparted any of his skill to any scholar?

Moreover, he accomplished, he tells us, cures which astounded physicians. Being a very superior man otherwise, he must have become famous. Yet Kopp, with all his learning in alchemy, declares that there is nowhere any mention of him before 1599. I know of but three statements which could be brought against Kopp's generalization, and all three break down under examination. In the first place there is a story traced to the *Sapientia Insaniens* of the Dutch alchemist, Jacob Tolle, a book which I understand to be a commentary upon the *Triumph-Wagen*,\* that the Emperor Maximilian I., in 1515, undertook to collect facts concerning the life of Basil Valentine, and that, unable to obtain any information, he finally sent to Rome and caused search to be made of the rolls of the Benedictine order, which search was unsuccessful. But this story is incredible. The busy Maximilian interested himself in everything except chemistry. In 1515 he was absorbed with Hungarian affairs. But these are the least of the objections to the tale. To suppose Basil Valentine was heard of in 1515 is almost to suppose he was living about 1470. In that case there must have been numerous persons near Mainz, who per-

\*If I have seen an entire passage of a book, or have otherwise conclusive evidence of its containing certain matter, I consider myself justified in saying so, even if I have not seen the whole book. In the present case, however, the story may be told somewhat differently by Tollius.

\*Ibid.

†Ibid.

‡Ibid.



sonally remembered so great a healer. Besides, how should his name have been missing from the Benedictine rolls? The facts must in some way have been mistaken by Tolle. Give me leave, then, to offer a conjectural emendation of the story. Let me suppose that, instead of Maximilian, it was the Emperor Matthias who made the investigation, or possibly even Rudolph II. The latter was a devoted alchemist; the former was at least in the way of hearing a good deal about alchemy. If it was Matthias, the date might be changed from 1515 to 1615, when the Emperor, having just concluded a long truce with the Turks, was enjoying unwonted leisure. If it was Rudolph, the search must have taken place not later than 1612. In either case the recent publication by Thölde would naturally have suggested the inquiry, and the fact that the name was not found is explained in the simplest manner by supposing there had never been such a man as Basil Valentine.

In the second place, Count Guden, in his History of Erfurt, is quoted as saying that Basil Valentine lived in 1413 in St. Peter's monastery in that town. But manifestly that could not have been the author of the *Triumph-Wagen*, with his *Franzosen-Sucht*. Besides, Kopp assures us that the roll of that monastery bears no such name.

In the third place, Sprengel, writing in Ersch and Gruber, cites a passage of Guanerius referring to Basil Valentine. I doubt if the citation has ever been verified. At any rate, since Guanerius died, in 1440, our author cannot have been intended by him.

Finally, as another difficulty, the question arises where could Basil Valentine have acquired his ideas, wild as they were, and his skill in chemistry? Paracelsus, the son of an eminent physician, running all over Europe in his thirst for knowledge, and undoubtedly a great man, might very well have gained such ideas directly or in-

directly from Arabian sources. But Basil Valentine, though by no means hiding his knowledge under a bushel, nowhere boasts, as far as I know, of any acquaintance with Arabic.

Thus, the attempt to sustain the hypothesis of a real Basil Valentine creates a new difficulty with every new circumstance and feature of the facts that we learn. Let us turn, then, to that hypothesis which ought logically to have been adopted at first, namely, that Thölde was himself the author, and see whether the facts may not fit into that better. Those which we have already had occasion to notice certainly do so.

But let us ask who was Johann Thölde? He was a man of means, part proprietor of a chemical industry, the salt works at Franckenhäusen, and the secretary for many years of the Rosicrucian Brotherhood, a society founded on literary fraud and saturated with it.

And how does this secretary of a society of humbug account for his possession of the MSS? Does his tale bear the marks of truth? The story is well known. The brotherhood pretended that their founder had been buried at the ripe age of 106 in the house of the Holy Spirit at Erfurt, having directed that his epitaph should read 'Post CXX annos patebo.' Accordingly, that time having elapsed, one of the pillars of the chapter-house burst and disclosed ancient books embodying the doctrines of the brotherhood. We have a list of some of those books, but the only ones of any consequence are the treatises of Basil Valentine. If you believe the story of the bursting pillar, you will believe these books authentic. If not, you will believe them to be the forgeries of Thölde and his brethren, who really stole the ideas of Paracelsus and in one only of the books inserted some solid chemistry.

When we once come to regard the *Triumph-Wagen*, no longer as antedating Copernicus,

but as a production of the age of Galileo, Harvey, Gilbert and Keppler, it does not appear as a marvelous performance. The only circumstance at which one hesitates is that a scientific chemist, whose mind moved in the world of reality and veracity, should have mixed the description of his experiments with so much degraded bombast. We can only surmise that the wealthy Thölde, or the master spirit behind him, purchased these secrets of antimony from some indigent chemist and worked them into the otherwise nonsensical book in which they appear.

C. S. PIERCE.

*STUDIES FROM THE ZOOLOGICAL LABORATORY, HARVARD UNIVERSITY.*

THE following abstracts of papers prepared in the Zoological Laboratory of the Museum of Comparative Zoology at Harvard College have been made by the authors. The final papers will be published as soon as the plates necessary for their illustration can be prepared. Other papers, not readily given in abstract, or requiring illustrations to make them intelligible in that form, will be published soon.

E. L. MARK.

*Ovogenesis in Distaplia occidentalis Ritter (MS.), with Remarks on other Forms. (Abstract.)* By F. W. BANCROFT.

THE material was all obtained on the coast of California. In the compound ascidian *Distaplia*, only, was it attempted to make the investigation at all complete. Here the development of the sexual organs, though in several respects simpler, conforms to the type described by Van Beneden et Julin in 1885. Both ovary and testis are derived from a common fundament, which, on account of the differentiated oogonia it contains, is recognizable in even the smallest buds of the older colonies.

One of the diagnostic characters of the genus *Distaplia* is the capacious brood

pouch in which the embryos are kept. It is attached to the zoöid by a narrow stalk and has usually been described as a diverticulum of the peribranchial sac. The embryos are arranged so that the youngest are at the tip of the organ. It was found to be not a simple diverticulum; the stalk of the pouch is double, consisting of two narrow tubes, one of which is a continuation of the oviduct, while the other opens into the peribranchial sac. The oviducal tube opens into the bottom of the pouch, and it is on account of this arrangement that the younger embryos are always found in the tip of the organ. In passing from the ovary to the pouch the ovum is greatly compressed, assuming the shape of a sausage, but becomes oval as soon as it has entered the pouch.

The test cells are seen to be derived from the follicular epithelium, and not, as Davidoff has maintained for this genus, from within the ovum. The cytoplasm of the test cells has been stained from the earliest stages on, and strands of cytoplasm are seen during all the earlier stages connecting the test cell with the follicle in somewhat the same way that Morgan has described. However, at this period, bends in the wall of the germinative vesicle and accompanying vacuoles in the cytoplasm are occasionally encountered, and it is likely that these appearances are what has been described by Davidoff as nuclear evaginations from which the test cells are formed. They are probably due to shrinkage. There are also deeply staining granules in the cytoplasm, which often have vacuoles around them, and then look exactly like Davidoff's figures of nuclear buds that have already become detached from the germinative vesicle. But they do not produce the test cells, as this author thinks. The test cells are found to take no part in the formation of the test of the embryo, as has recently been maintained by Salensky. The outermost

follicular epithelium, which remains behind in the ovary when the ovum passes into the pouch, forms a very conspicuous corpus luteum, which persists for a considerable period.

In the colonies studied, both the youngest buds and the the adult zooids contained about the same number of oögonia, so that in these the whole of the ovogenesis consists in growth and maturation only. The yolk bodies, which are very large, begin to be formed at the periphery of the ovum when it has reached about half its final diameter. At this time the germinative vesicle has reached its maximum size; it has a full outline, a conspicuous stained network and a large nucleolus. From now on, while most of the yolk is formed and the ovum acquires the last seven-eighths of its ultimate volume, the germinative vesicle decreases in size, until it has but half its maximum diameter, acquires a stellate outline and a marked avidity for most stains. The shrinking of the germinative vesicle, then, is not associated with maturation in this case, but with yolk formation.

The nucleolus, though usually obscured by most stains, persists with little change throughout this shrinking. It does not form the stellate body found in the old ova, as Davidoff maintained, but is found within this body, which is itself the remains of the germinative vesicle. The nucleolus at this stage is quite complex, consisting of a homogeneous cortex, an eccentric finely granular medulla, and within the latter several very highly refractive bodies, the largest of which may have a granular appearance. During the greater part of the growing period these refractive bodies are the only substance in the germinative vesicle that takes the chromatin stain with a methyl green and acid fuchsin combination. However, shortly before the egg leaves the ovary chromatin is detected in

other regions of the vesicle, so that it is probable that the tetrads are not formed from any part of the nucleolus. These refractive bodies persist even after the ovum has passed into the oviduct and the rest of the nucleolus, together with the germinative membrane, can no longer be seen.

The tetrads, of which there appear to be normally twelve, are formed during the passage of the egg through the oviduct. Two polar cells are formed, but in neither of the divisions accompanying their production nor in any of the earlier cleavages has any centrosome, aster or spindle fibre been found, although several good preparations of these stages have been obtained. In all of these processes the amount of granular undifferentiated cytoplasm is very small; by far the greater part of the ovum is filled with yolk bodies, between which no interstitial cytoplasm can be detected. It may be that the absence of these characteristic accompaniments of mitosis is due to the small amount of active cytoplasm present.

*Observations on Non-Sexual Reproduction in Dero vaga.* (Abstract.) By T. W. GALLOWAY.

BUDDING may take place in any of the setigerous segments from the 16th to the 21st.

Number of segment.....	16	17	18	19	20	21
Percentage of occurrence...	7.6	15.3	33.2	26.7	7.6	4.6

In the anterior zooid subsequent bud-zones are produced in the same segment in which the first occurred. When the posterior individual reproduces, the bud-zone may be in the segment bearing the same number as that of the anterior zooid, or it may be in front or posterior to that segment. It is thus the posterior zooid which introduces the variability. In *Dero* the relation between the normal increase of segments and budding is such as to suggest



that the latter is a specialized form of the former.

The place of separation is interseptal; the anterior half-segment produces an anal segment and a preanal, undifferentiated, segment-forming zone; the posterior half forms four cephalic segments and the prostomium.

The ectoderm by ingrowths between the longitudinal muscle bands produces in the posterior zoöid the brain, the circumoesophageal connective, the sub-oesophageal ganglia, four pairs of ventral bristle-sacs and two latero-ventral invaginations, the walls of which contribute to the formation of the buccal wall. The floor and roof of the mouth are also ectodermal, but are formed, upon the separation of the zoöids, by the free mid-dorsal and mid-ventral margins of the body wall, which are drawn into contact with the entoderm by muscular action. In the anterior zoöid the ectodermic ingrowths fuse with one another and with mesodermal elements to form an undifferentiated zone, from which new segments are added to this zoöid. The nerve cord, the dorsal and ventral bristle sacs, and the peripheral portions of the nephridial organs, are contributed by the ectoderm.

The entoderm increases in thickness throughout the bud-zone by the multiplication of sub-epithelial cells. In two regions this becomes pronounced. In the posterior zoöid a thick wall of long, columnar, ciliate epithelial cells is produced, surrounding the old tube. This outer wall soon becomes separated from the old wall by a distinct space, the lumen of the new pharynx. Anteriorly this new pharyngeal wall becomes continuous with the ectodermal portion of the wall of the mouth; posteriorly it extends to the dissepiment bounding the bud-zone. The wall of the old gut continues functional until the individuals separate, and is then detached and swallowed. In the anterior zoöid there is a thickening of

entoderm immediately in front of the future plane of division. This arises in a way wholly similar to the pharyngeal wall, and, like it, becomes separated from the wall of the gut. It is ciliated and is destined to become the wall of the pavilion, which probably subserves a respiratory function. From the mesoderm arise new muscular fibres, blood vessels and dissepiments.

*Effect of Temperature on Growth of Tadpoles.*  
(Abstract.) By T. W. GALLOWAY.

TADPOLES of *Rana*, *Amblystoma* and *Bufo* were reared, without other food than was contained in the eggs, under different temperature conditions (varying from + 16° to + 25°C.), to an age of 30 to 70 days. Through a comparison of the total weight, the dry weight, the amount of water and the ratio of the dry weight to the total weight, the following conclusions were reached: (1) Increase of temperature, within the above limits, accelerates cleavage and the rate of imbibition of water (especially the latter), but does not appear to produce any definite change, either of increase or decrease, of formed substance; (2) organisms reared in the warmer conditions tend to attain a slightly higher maximum percentage of water than those subjected to lower temperatures; and (3) individuals reared for sometime in a low temperature showed, after transfer to a higher temperature, a greater rate of imbibition of water than those kept from the beginning in the warmer chamber.

*Structure and Development of the Antennal Glands in Homarus americanus.* (Abstract.) By F. C. WAITE.

THE adult organ consists of three portions, an endsac, labyrinth and vesicle. The endsac lies spread over the dorsal face of the labyrinth, and closely applied to it. These two portions of the gland are in communication at one point only, which is in



the anterior region of the organ. The labyrinth is continuous at its anterior median lobe with a short duct which leads to the exterior and opens on a tubercle on the base of the antenna. The large vesicle lies dorsal to the endsac and opens into the duct leading from the labyrinth, but has no direct communication with either the endsac or labyrinth. The histological structure of the labyrinth and endsac are different and the transition at the point of communication between their cavities is sharp. The histological structure of the vesicle is very much like that of the labyrinth.

The first appearance of the organ in the development of the embryo is at the time when the first and second pair of antennæ, the mandibles and the first maxillæ are marked off. This is approximately 15 to 18 days after egg extrusion in summer (August) eggs. The organ at first consists of a differentiation of certain mesodermic cells in the axis of the second antenna near its proximal end. These form the endsac. The lumen is intracellular. About ten days after the first differentiation of the cells which are destined to form the endsac, and at a time when this part of the organ is well marked, there appears an ectodermic ingrowth from the ventral face of the second antenna. It is at first solid, but within a short time an intercellular lumen is formed. From this ectodermic ingrowth arise the labyrinth, the duct to the exterior, and the vesicle. Thus the two parts arise independently, one from the mesoderm, the other from the ectoderm, and each has characteristic histological conditions throughout development. They are both well marked and with distinct lumina at about six weeks (for summer eggs) after egg extrusion, but not until a comparatively late period of embryonic development (about one month before hatching) do the lumina of these two parts become confluent. At the time of hatching each part is a re-

latively simple sac, but during larval life a complexity approaching that in the adult organ is reached. This is brought about by a series of evaginations of the walls of the sacs, which later anastomose in a variety of ways, and not by the coiling of a tubule. The histological conditions seem to indicate that the organ is not functional until the beginning of larval life.

The results obtained as to the development are in general accord with the conditions found by Kingsley in Crangon and by Bouchinsky in Gebia, but are at variance with the development of the organ in *As-tacus* as described by Reichenbach.

---

*RAISED SHORE-LINES ON CAPE MAYSI, CUBA.*

At the eastern end of the island of Cuba, on and in the vicinity of the promontory known as Cape Maysi, is the most magnificent example of raised shore-lines as seen from the ocean that I know of. They are in the form of huge wave-cut benches extending with perfect regularity and practical horizontality along the face of a long moderate slope and around several promontories. When a profile of the latter is seen from a passing ship the sharp-cut, step-like form readily attracts the attention even of the unscientific observer. The terraces are found one above another at somewhat irregular intervals, are of different degrees of development, possibly as much as a dozen in number, and seem to extend to an altitude of about 1,000 feet above the sea. Above the last terrace visible the land has a topography indicative of sub-aërial erosion. The view is backed by the high range of the Copper Mountains, whose crest along this portion of the island is smooth and even compared with most West Indian mountain ranges.

To the geologist the terraces of Cape Maysi are chiefly interesting because they demonstrate a recent uplift of this part of the island of Cuba. This is singular, be-

cause the island of Jamaica, but little more than 100 miles distant, is without evidence of such a very recent uplift. To a certain extent the two islands have had a different geologic history.

The extreme recency, geologically speaking, of the uplift of Cape Maysi is indicated by the perfection of the terraces. They have suffered practically no sub-aërial erosion. Although the land is a comparatively steep slope, constituting a very favorable situation for erosion, no gutters, ravines or valleys were seen from the ocean, with two exceptions. Even these exceptions tell of the newness of the land surface. They are two deep narrow cañons formed by streams flowing down over the terraced slope. Where exposed on the precipitous face of one of the large raised sea-cliffs, the cañons are just as narrow at the top as at the bottom.

I am inclined to believe that the beginning of this series of unsteady or periodic uplifts of the eastern end of Cuba belongs later in the geological scale than the opening of the Modern or present period, and it is continuing at the present day. The sea is now engaged in forming a sea-cliff and narrow submarine shelf precisely like the raised shore-lines above it. In not a very long time, perhaps a few hundred years, another incipient uplift will be due and another and lower bench begun.

These few remarks have been given to stimulate the study of this eastern Cuban region, which will result in some important additions to our knowledge of West Indian geology. Undoubtedly other travelers have noticed these beautiful terraces on Cape Maysi and studied them from passing ships, as I have, but a landing should be effected on the coast and a close examination of them made, particularly of the two dark cañons above mentioned.

OSCAR H. HERSHEY.

JUNE 24, 1898.

#### CURRENT NOTES ON ANTHROPOLOGY.

##### ARCHIVE OF THE SCIENCE OF RELIGION.

THE second number of this journal confirms the favorable opinion created by its first issue.

Professor Siecke, of Berlin, begins a profound study of the god Rudra in the Rig Veda (the Vedic prototype of Siva), and one by Dr. Waser on the Greek Charon. Professor Steinthal discusses the associations of the toad in mythology, while the editor, Dr. H. Achelis, considers the theory of the origin of religion from social psychology. Several reviews close the number, one a note upon 'kynanthropy,' or the transformation of the human into the dog form. This is allied to the better known 'lycanthropy,' but is familiar even in American folk-lore, where the 'black dog' is still regarded as the uncanny embodiment of the Evil One. The article reviewed is by Roscher in the *Transactions* of the Saxon Society of Sciences. The *Archiv* is published by J. C. B. Mohr, Leipzig.

##### ARCHAEOLOGY OF CORSICA.

A REPORT by M. Caziot in the *Bulletin* of the Paris Anthropological Society (1897, Fasc. 5) contains new information on the archaeology of Corsica.

Neither the caverns nor the fields yield traces of palæolithic man; but numbers of axes in polished stone, points of arrows and lances, scrapers and hammers show that in neolithic times the island was inhabited.

Pure native copper occurs in the mountains, and was exploited during the neolithic epoch. The quarries are still found, and many objects in pure copper must be referred to the late stone age. To this time, also, are attributed the dolmens and ancient graves where inhumation was practiced. Pottery in that epoch was scarce and rarely made.

Following the close of the polished stone age, those of bronze and of iron are dis-

tinctly marked, represented in history by the successive conquests of the Etruscans, Romans and Merovingians. Megalithic monuments and remains of ancient walled cities attest the conflicts of these possessors of the land.

#### THE RACES OF EUROPE.

DR. J. DENIKER, a high authority, gives in *L'Anthropologie* for April the results of his long and minute studies on the constitutive races of Europe outside of those who we know were historical immigrants (Semites, Finns, Lapp, Huns, Gypsies). He makes six 'primary' races as follows: (1) Blond, dolichocephalic, tall, in the north; (2) blond, sub-brachycephalic, short, in the east (Great Russia, eastern Prussia); (3) dark, short, dolichocephalic (Iberians); (4) dark, short, brachycephalic (Celts, Rhetians); (5) dark, tall, mesocephalic (littoral of Mediterranean); (6) dark, tall, brachycephalic (about the Adriatic).

To these he would add several 'secondary' races, with the somatic criteria more or less mixed.

He does not claim that these are original types. They are all the result of admixtures of several lines; but the distinct prevalence over wide areas of the characteristics named justify the assumption of lineage.

D. G. BRINTON.

UNIVERSITY OF PENNSYLVANIA.

#### NOTES ON INORGANIC CHEMISTRY.

ATTENTION was recently called to the determination of the atomic weights of cobalt and nickel by T. W. Richards, of Harvard, in conjunction with Cushman and Baxter. The method used was the determination of the bromin of the bromids by weighing as silver bromid in a Gooch crucible. In the last *Zeitschrift für anorganische Chemie*, Clemens Winkler, of Freiberg, criti-

cises their work in three respects: presence of the oxybromid; possible presence of hydrobromic acid not removed by heating in nitrogen; use of Gooch crucible. He considers the method used by himself in his work a few years ago much less liable to inaccuracy. In this the electrolytically deposited metal was acted on by excess of iodine in presence of water, and the iodine not used measured by titration with standard sodium thiosulfate solution. Winkler's results are  $Ni = 58.86$  and  $Co = 59.51$  as against Cushman's  $Ni = 58.69$  and Baxter's  $Co = 58.99$  ( $O = 16$ ). It is noticeable, however, that while these results differ among themselves, in both cases the atomic weight of nickel appears to be less than that of cobalt, while the periodic law would seem to require the reverse to be the case.

In the same number of the *Zeitschrift*, Alfonso Cossa, of Turin, announces the discovery of tellurium in the concretions on the inner wall of the crater of Vulcano (Lipari Islands). These concretions are largely of potassium aluminate; thallium, cesium and rubidium also being present. In the same region large quantities of potassium fluosilicate are found. The amount of tellurium recovered was about 2 gm. per 3 kilos material. Selenium is present in the stalactites of sulfur, but in far smaller quantities than tellurium.

PROFESSOR LEBEAU has been experimenting on the action of the heat of the electric furnace on the emerald in a carbon tube. The experiments were carried out in some cases on as much as 100 kilos of emerald. With a current, 950 ampères, 45 volts, most of the silica distills off and there is left a melted mass with metallic luster. This is a mixture of carbids of aluminum and of glucinum, and silicids of iron and of carbon. Dilute acids dissolve the mass, giving solutions of aluminum and glucinum. If hydrofluoric acid is used, fluorid of glucinum is



obtained, fluorid of aluminum being insoluble.

IN another number of the *Comptes Rendus*, M. Lebeau describes fully the fluorid of glucinum. It is exceedingly soluble in water and even alcohol, and is deliquescent. It fuses at a fairly high temperature in an inert atmosphere, but heated in the air it forms an oxyfluorid  $5\text{GlF}_2, 2\text{GIO}$ , also soluble in water.

ACCORDING to Wm. A. Bone and John Wilson, in the latest *Proceedings* of the Chemical Society (London), acetylene when exposed in closed glass tubes to the sunlight is gradually decomposed. In June a faint brownish deposit is observable at the end of two or three days. No deposit is found on any part of the tube not exposed to the sunlight. The nature of the black deposit has not yet been fully determined, but it seems to be a very dense hydrocarbon; no benzene nor naphthalene could be found. This decomposition is what might be expected from the endothermic character of acetylene, and it may possibly come to play a part in the industrial manufacture.

J. L. H.

#### SCIENTIFIC NOTES AND NEWS.

##### THE CHICAGO ACADEMY OF SCIENCES.

WE have received the 14th annual report of the Chicago Academy of Sciences, covering the year 1897. From the report of the Secretary and Curator, Mr. F. C. Baker, it appears that the number of visitors to the Museum during the year was over 245,000, including the formal visitation of 133 classes from the Chicago schools, attended by their teachers. Thirteen popular lectures were given, with an average attendance of 300. The accessories to the Museum numbered 15,457, twenty-eight collections having been presented. The President of the Academy, Professor T. C. Chamberlin, in his report states that the survey of the natural phenomena of Chicago and its environment, which has been in progress

since 1892 under the auspices of the Academy, has made progress during the year. Its work has been so connected, by an informal understanding, with that of the United States Geological Survey as to avoid needless duplication and to render the work of each serviceable to the other. As the fruit of this and by the generous assent of the Director of the United States Geological Survey, a bulletin on the Pleistocene formations of the Chicago area and of the outlying territory, prepared by Mr. Frank Leverett, of the National Survey, has been published by the Academy, and has already proved itself helpful to citizens of Chicago and especially to students of the geology and geography. An elaborate and amply illustrated bulletin on the mollusks of the Chicago area by Mr. Baker is now in press. Three additional manuscript reports are essentially completed, and it is anticipated that bulletins on well-borings, on birds and on the Phenogamous and Cryptogamous Plants of the region will be issued during the coming year. The National Survey has during the year completed the field work upon four of its standard atlas sheets, embracing the greater part of Chicago and its environment, based upon contour maps previously prepared. While these are wholly the work of the United States Geological Survey, and will be published by it, they contribute effectively to the ends sought by the Survey of the Academy, in the presentation to the people of Chicago and to the schools, of ample and trustworthy data relative to the natural phenomena of the city and its environment.

##### GENERAL.

PROFESSOR RUDOLF VIRCHOW has been made an Associate of the Paris Academy of Sciences. He was for many years a corresponding member.

PROFESSOR ROBERTS-AUSTEN has been elected president of the British Iron and Steel Institute.

MR. HERBERT BOLTON, who for the last eight years has held the post of assistant keeper in the geological department of the Manchester Museum, has been appointed to the curatorship of the Bristol Museum. The Manchester Museum advertises for a successor to Mr. Bolton. It offers a salary of \$400 a year!



DR. KRIECHBAUMER has been made a curator of the State zoological collections at Munich.

SIR GEORGE STOKES gave the presidential address before the Victoria Institute, London, on July 18th, his subject being 'The Perception of Color.'

THE ROYAL SOCIETY has appointed a committee which it is expected will cooperate with a committee appointed by the British Colonial Office in investigating the causes of malaria, more especially the relation of the mosquito to the malarial parasite. It is expected that grants of money will be made by the Royal Society and the Colonial Office for the purpose of sending a commission to India and Africa.

THE directors of the Ben Nevis Observatories announce that the high- and the low-level observatories at Ben Nevis will cease to exist in October owing to want of funds. The directors state that by the establishment of these observatories a great experiment has been carried out with signal success. A series of hourly observations has been obtained by night and by day without a break over a period of 15 years.

THE Berlin Academy of Sciences held on June 30th a public meeting to celebrate the birthday of Leibnitz. Professor Waldeyer, who presided, spoke on the scientific work of the Academy, and the newly elected members, Professor Engelmann and Kekulé von Stradonitz, made inaugural addresses.

PLANS are being made for the foundation of a French *Association des Anatomistes* to include those interested not only in human and comparative anatomy, but also students of histology, embryology and anthropology. The Association will meet annually in some university center, Paris having been chosen for the place of the first meeting, to be held next year.

THE Archæological and Historical Society of Belgium held its annual meeting at Enghien from the 7th to the 10th of the present month.

THE sulphate of ammonia committee, concerning the functions of which we are not informed, advertises a prize of 500 guineas for the best essay on the utility of sulphate of ammonia in agriculture; the essays must be received not

later than November 15th, by W. G. Blagden, Esq., 4 Fenchurch Ave., London, E. C.

THE *British Medical Journal* reports that a department for the treatment of hydrophobia by Pasteur's method and for scientific research on the subject of hydrophobia has just been opened in the Berlin Institute for Infectious Diseases (Koch Institute). This establishment is the first of its kind in Germany. Apparently rabies is becoming more frequent in Germany. In spite of the stringent legislation on muzzling, five persons died of hydrophobia in Prussia during the year 1897.

THE British House of Commons devoted its session of July 25th to a somewhat desultory discussion of the Vaccination bill. A clause has been inserted to the effect that no parent or other person should be liable to any penalty under Section 29 or Section 31 of the Vaccination Act of 1867, if within four months from the birth of the child he satisfied two Justices in petty sessions that he conscientiously believed that vaccination would be prejudicial to the health of the child, and within seven days thereafter delivered to the vaccination officer for the district a certificate of such conscientious objection.

*Nature* states that Professor Max Weber, of the University of Amsterdam, will leave Europe in October next, for Sourabaya, Java, to take command of a scientific expedition, projected by the Society for the Biological Investigation of the Netherlands Colonies, for the zoological, botanical and oceanographical exploration of the seas of the Indian Archipelago. The course of the expedition, which will last about a year, is divided into two sections. The first, starting from Sourabaya, will pass through the Timor and Tenimber groups of islands to the Aroos and Ké Islands and thence to Banda or Amboina, a total distance by the route selected of about 2,500 English miles. The second section, starting from Banda or Amboina, will pass between Halmahera and Celebes through the chain of islands leading up to the Philippines, and return to Java by the channel between Celebes and Borneo, making a trajet of some 3,000 miles.

A DISPATCH from Vancouver, B. C., says that

Dr. Terwange, who has been for some time making preparations, left for Skaguay on Friday to look for Herr Andrée and his balloon. At Skaguay he will be met by eight other members of the party and M. Varich, head of the expedition. It was intended to make the search for Andrée first in a balloon capable of carrying 9,000 pounds. It was decided to take a smaller and speedier air-vessel, however, and one which will carry 5,000 pounds was built in Vancouver, B. C. Supplies have been sent around by St. Michael's, and will be cached at different points along the river. The expedition is under the auspices of the Geographical Society of France.

WE learn from *Natural Science* that the government of New South Wales has fitted out a deep-sea trawling expedition for experimental fishing off the coasts of the colony. Mr. E. R. Waite, of the Australian Museum, is attached as naturalist, and much valuable material, including many new species, is finding its way to the Museum.

THE botanical expedition to the La Plata Mountains of southwestern Colorado, organized by Professor C. T. Baker, and accompanied by Professors S. M. Tracy and F. S. Earle, has returned after being five weeks in the field. It was originally intended to extend the work over a much longer period, but the illness of one of the members of the party prevented. The work will be continued another year, which is amply justified by this season's results. Collections of the greatest value have been made, the number of specimens taken in the five weeks exceeding twenty-five thousand. Many novelties (a new *Lupinus*, a new *Gilia* and other new things) and many rarities (as, for instance, *Ranunculus Maccauleyi* in flower and fruit, *Ligusticum eastwoodiæ*, *Trifolium brandegei*, *Astragalus heydenianus*, *A. lonchocarpus*, *A. scopulorum*, *A. wingatensis*, etc.) were collected in quantity and will be issued in the sets which have been subscribed for by most of the greater herbaria of this country and Europe.

THREE Italian investigators, R. Nasini, F. Anderlin and R. Salvadori, who have been engaged in the study of gases emanating from the earth, write to *Nature* that in the spectrum of

the gases "of the Solfatara di Pozzuoli, which contain argon, we have found a sufficiently bright line with the wave-length 531.5, corresponding to that of corona 1474 K, attributed to coronium, an element not yet discovered, and which should be lighter than hydrogen. This line has never before been observed in earthly products. Besides we have noted the following lines: 653.5, 595.5, 536.2. In the spectrum of the gases gathered from the Fumarole of Vesuvius we have observed the lines: 769.5, 631.8, 572.5, 636.5, 441.5, and again 595.5. All these lines do not belong to the spectrum of argon or helium; they show a coincidence or proximity only with some unimportant lines of various elements, such as iron, potassium, titanium. Considering the conditions of our experiments, the presence of these elements in the gases we have studied is not probable. The line 572.5 is near to one of nitrogen, but being the only visible line of the spectrum of this gas it cannot be attributed to it. Besides coronium we have thus probably other new elements in these gases."

DR. J. N. ROSE, of the National Museum, contributes to the ninth report of the Missouri Botanical Garden a paper of several pages, illustrated by three plates, on several Agaves which have bloomed in the Botanical Garden at Washington. One of these, the original home of which is not known, is described as new, under the name *A. Washingtonensis* Baker & Rose. Some years since, Professor Williams described and figured, for the first time, fruiting specimens of the rather common lichen *Parmelia molliuscula*. In a brief note of a recent publication in the same report of the Missouri Garden, Mr. Henry Willey calls attention to the existence in his collection of another specimen in fruit.

A DISPATCH to the daily papers from Vienna says that Dr. Leo Lillienfeld, of that city, has demonstrated to the Chemical Congress, in session there, the discovery of a method of producing artificial albumen, identical with natural albumen, which hitherto, it has been believed, could only be produced by organic means.

WE called attention recently to the prize of \$10,000 offered by the Belgian government to

the inventor of a match containing no yellow phosphorus. Mr. Cunningham has called attention to the fact that if the head of an ordinary 'safety' be dipped in the paste which is put upon the sides of the match box, and which contains red phosphorus and sulphide of antimony, the match will be found capable of igniting upon any surface. Meanwhile it is said that in France the State engineers have succeeded in giving a formula for making lucifer matches which does not include either white phosphorus or any substance injurious to the health of the hands or that of the public. Machinery has also been invented which will contribute to the health and safety of the hands. The machinery has been tested; after a few improvements have been made in it, it will be generally adopted in the government lucifer match factories.

THE Governor of Madagascar, the native government of which has recently been supplanted by that of civilized France, has issued an order forbidding any except Frenchmen to collect fossils in the island. *Natural Science*, which takes this information from the *Geographical Journal*, which finds it in the *Politique Coloniale* for May 25th, properly asks whether the naturalists of France, official and otherwise, have been consulted on this subject, or whether it is merely the order of a politician ignorant of the methods of scientific men.

DR. GEORG WALTERMATH, of Hamburg, is insatiable of moons. He has sent us, under the date of July 20th, an announcement of a third moon for the earth. This moon is said to be 427,250 kg. distant and is 746 km. in diameter. It is nearer than Dr. Waltemath's other moon, and is a 'wahrhafter Wetter-und Magnet-Mond.' Perhaps it is also the moon presiding over lunacy.

UNDER the editorship of Professor Joseph S. Ames, of Johns Hopkins University, the Harpers announce a series of scientific reprints similar in plan to Oswald's *Klassiker der exacten Wissenschaften*. The first volume of the series will include the papers by Guy-Lussac and Julien Thomson on the free expansion of gases, and the second, Fraunhofer's papers on prismatic and diffraction spectra.

THE Berlin correspondent of the London *Times* telegraphs that an appeal has just been made to patriots, thinkers, writers, and to the world of thought and culture in Germany at large, to unite together in the foundation of a Kaiser Wilhelm Library for Posen, similar to that subscribed for and presented to the city of Strassburg after the war of 1870-71. The library is to be presented to Posen for the purpose of furthering German culture and influence among the Slavonic population and for combating the ever-increasing antagonism of the Poles. The importance of Germanizing the Poles has been recognized as a growing necessity, and for that purpose a provincial library in Thorn and a technical high school in Danzig are to be established. The ultimate foundation of a German university in the province of Posen is considered as a future possibility. In the meantime donations and offerings of books are earnestly solicited, and by spreading German knowledge it is hoped to diffuse a strong feeling for German ideas among the peasantry of East Prussia.

#### UNIVERSITY AND EDUCATIONAL NEWS.

PROFESSOR SIMON NEWCOMB will next year resume the active superintendency of the work in mathematics and astronomy in Johns Hopkins University. He expects to give a course of lectures on the Encyclopædia of the Mathematical Sciences, and will especially direct students pursuing advanced work in celestial mechanics.

THE chair of physics in McGill University has been filled by the election of Mr. Ernest Rutherford, and the chair of organic chemistry by the election of Dr. J. W. Walker. Professor Rutherford comes from New Zealand, but has recently been in residence at Trinity College, Cambridge, holding the Couttes-Trotter Studentship. Professor Walker has been since 1896 lecturer in organic chemistry in University College, London.

THE assistant professorship of civil engineering in McGill University is vacant. Candidates should apply by letter to the principal, whose present address is 81 Ifley Road, Oxford.

BUILDINGS of the Niagara University, a Cath-



olic institution near Niagara Falls, have been destroyed by fire, supposed to have been of incendiary origin, involving a loss of \$70,000.

HERR VON MIQUEL, Prussian Minister of Finance, has proposed a plan for taxing professors of medicine who also practice. His plan would result in paying no salary to professors who have a practice of the value of \$5,000.

DR. STEVEN CROWE and Dr. E. S. Pillsbury have been elected lecturers in bacteriology in the College of Physicians and Surgeons, San Francisco.

THE University of Pennsylvania has this year awarded five senior fellowships, two honorary fellowships, fifteen regular fellowships for men and five for women and the Hector Tyndale Fellowship. The awards in science are as follows: *Senior Fellowship*: Chemistry, W. L. Hardin. *Honorary Fellowships*: Botany, A. F. Schweley and S. C. Schmaucker. *Fellowships*: Pedagogy, C. D. Nason; Chemistry, Alfred Tingle; Biology, J. M. Greenman; Mathematics and Astronomy, J. M. Hadley; Sociology, G. R. Wicker; Mathematics, J. B. Faught. *Fellowships for Women*: Psychology, A. J. McKeag; Chemistry, L. G. Kollock. *On the Hector Tyndale Foundation*: Physics, M. G. Lloyd.

DR. GEORG KLEBS, of Basle, has been appointed professor of botany in the University at Halle. Dr. Hefs has been promoted to a full professorship of physics in the Lyceum at Bamberg. Dr. Holde has qualified as docent in chemistry in the Technical Institute at Charlottenberg, and Dr. Kopsch in anatomy in the University of Berlin.

#### DISCUSSION AND CORRESPONDENCE.

##### STABILITY IN GENERIC NOMENCLATURE.

IN the June number of the *Botanical Gazette* Dr. B. L. Robinson has called attention to the fact that the Rochester Rules do not provide criteria for determining the application of generic names. It is also pointed out that a strict interpretation of the principle of priority would demand that the first species placed under a genus should serve as its nomenclatorial 'type,' to which the name should remain attached. The execution which such a rule would work

among the older names is, it appears, the reason why the makers of the Rochester Code have hesitated to enact or put it in practice. This omission is criticised as gravely inconsistent in a system of 'absolute and decisive character.'

Much nomenclatorial discussion has failed of any definite purpose for lack of agreement as to the nature of the taxonomic problem. Consciously or unconsciously, systematists belong to two schools, representing, for the purposes of illustration, the idealists and realists. According to the former, systems of classification and their categories are mental concepts merely—pigeon-holes, so to speak, into which the individual units of biologic phenomena can be assorted. If the arrangement of the pigeon-holes prove too inconvenient, changes may be necessary, but these are made with reluctance, and it is fondly hoped that each readjustment may be the last. The idealistic systematist views nature from the standpoint of the system, and while he may not be a philosophic idealist as well, and deny the material existence of the objects of his study, he not infrequently declares, and uniformly acts on the opinion, that species, genera and families do not exist in nature, but are *made* by the naturalist. In accordance with this view, the various categories mentioned consist primarily of *definitions* to which names are attached. The usage of the earlier systematists corresponded somewhat to our present custom of patenting new inventions. If the definition or specification proved faulty it was set aside, name and all, and a supposedly improved combination of characters was arranged for the consideration of posterity. This was entirely just and logical, for if the genus (definition) did not correspond to anything in nature it was of no use to the naturalist and should properly give way to the clearer concept of the later student with his presumably wider knowledge of forms. No uniformity nor stability could come, however, from such a method; biologic progress would mean an endless succession of names, an infinite mass of competing generic concepts to be sifted and arranged, constituting an almost insurmountable barrier between nature and formal knowledge. To avoid this threatened chaos it became customary to retain older names, emend the descriptions and credit



the genus to the emendator. Confusion also attended this practice in that it soon became difficult to ascertain the character and importance of the changes worked by successive students, and opinions greatly differed as to the merits of the various references, so that on the ground of convenience merely there has been an increasing tendency to credit the genus to its original author, the inventor of the name, and ignore the fact of subsequent emendation. This is, then, a practical abandonment, for nomenclatorial reasons, of the custom of treating the genus as a mental concept, and the purport of the original description has come to be so far ignored that the Rochester Code bases botanical nomenclature on a work which contained no definitions of genera, necessitating that all knowledge of them be gained by inference from the included species.

But the above view as to the nature of genera is as false in theory as it has proved impossible in practice. Species, genus, family and order are as actual and real as regiment, division and corps or other collective nouns. It may not be possible to define the terms to the satisfaction of all, but for nomenclatorial purposes it is quite sufficient to know that a species is a group of individuals, and a genus a group of species. If we think of a species as an island in the sea of extinction a genus is an archipelago, a group of neighboring islands. There being no biological latitude and longitude, we are obliged to indicate the islands and the group by describing them. The history of geographical discovery has proved that it is not easy to distinguish by description between numerous similar islands, and systematic science has in the last decades abandoned the description as the final resort for the interpretation of the species and taken to the original specimen or 'type.' It is still protested by the surviving idealists that no single specimen can give an adequate idea of the species, and nobody claims that it can, but the desirability of a single definite nexus between nature and science is rapidly becoming patent to all. A complete description of a species can only be drawn after it is known throughout its range and variations, and until its entire life-history has been ascertained, but the preservation of a type specimen

renders easy and definite the settlement of questions which could in many cases never be positively decided otherwise. The discoverers of an island may reach it from different sides, and may disagree in the accounts of what they saw, but if their points of observation are known later travelers can harmonize the discrepancies, correct the errors and complete the description.

The method of types is rapidly becoming universal in the study of species, but with respect to genera the idealists are still much more in evidence. The case is, however, exactly the same. A genus being a group of species, it is more satisfactory and final to know one of the species than to hear any amount of general remarks about the group as a whole, especially if the region has not been thoroughly explored and mapped. The discoverer of a new genus simply recognizes that a certain species, or more, lies at a distance from any of the groups which have been previously designated as genera. In a majority of cases he becomes aware of this fact through observation on some single species, which he proceeds to describe and figure with special care. He may not know the size, direction or extent of his new archipelago; all the general characters he alleges as features of the group may fail in the light of later study, and yet the fact would remain that he had first recognized as distinct from all others that particular group of species. As before, the genus cannot be truly defined, the characters by which it is distinguishable cannot be formulated, till all the species are known. The characters might, indeed, long elude us without impairing the distinctness of the genus. The species and genus, in the realistic view, are in an important sense independent of characters, the formal characters being the means of pointing out the group, rather than the primary ground of its existence. The description, whether by ancient or modern writer, loses its sanctity and is distinctly subsidiary in authority to the type.

The idealistic theory having proved impracticable, the method of types is being rapidly substituted, even without the recognition of a logical base for its use. An objection is sometimes raised that as the early systematists did

not work under this method it cannot be justly applied to their groups. This criticism is, however, entirely misplaced, for strict justice would result in setting aside nearly all their genera, as they served those of their predecessors, for scarcely any were adequately defined. The modern custom is not only just, but generous, since it proposes to incorporate and give permanent recognition to groups which under their authors' theories would be in continued jeopardy.

The method of definition and the method of types tend, indeed, to converge in practice and might ultimately coincide as knowledge became perfect. The point of view, however, has a very important bearing on the question of stability of generic names during the constant process of change which increasing insight into nature must work in any system of classification. If a genus is a definition its application will continue a matter of individual preference and doubt, but if a genus is a group of species it will, in accordance with the law of priority, bear the oldest name first used to designate any of its members. The method of types as applied to genera rests, accordingly, on a more important consideration than its convenience as a rule of nomenclature, and the use of the first species as the type of the genus in cases where the author did not himself designate a type has a more important sanction than attaches to it as an extreme development of the principle of priority, for it, or some similar rule, is necessary to any *system* which undertakes to produce stability in the application of generic names. The only alternative method yet suggested is that of elimination; it is an invention of the idealistic school, is ambiguous and difficult of application, and is directly inimical to stability, since one readjustment in generic names may necessitate numerous others, even in distinct families. The method of types renders the application of generic names absolutely stable, and by this very stability provides the flexibility so necessary in allowing classification to keep pace with increasing knowledge. To secure these ends seems quite as important as much of the existing legislation, but several American botanists of prominence to whom these reasons have been presented at length, while admitting the cor-

rectness of the contention, hesitate, like Dr. Robinson, to advise the sweeping changes which would be required.

The second element which, if not overlooked, has not been formally reckoned with in plans for nomenclatorial uniformity is human nature. Some have believed that almost any system or treaty of agreement once adopted by a majority would soon become universal.

Drs. Kuntze and Robinson deny this with emphasis. The former says: "The rules of nomenclature should neither be arbitrary nor imposed by authority. They must be founded on considerations clear and forcible enough for every one to comprehend and be disposed to accept." (Codex Emendatus, Art. 2.) And Dr. Robinson makes two separate declarations to the same effect: "Surely those who have themselves discarded hundreds of names which had stood unchallenged for nearly a century should not feel that they are establishing their system merely by putting it into use. The only way it can be established is by making it so reasonable and consistent that it will command general respect and approbation." (P. 438.) "But no system which is not in itself logical is likely to stand the test of time." (P. 440.)

These strike the keynote of the whole question of systems. There are those, and not a few, who will yield adherence to no system which does not appear to them coherent, complete, catholic. The system, if anything, must be everything; considerations of convenience have little weight with these true systematists. Any exception, deviation or ambiguity is a blot which disfigures the whole fair page and must be removed at any cost of time or pains. It is of no use to say that all nomenclature is for convenience merely; that it is a means, not an end; that its purpose is to save, not increase, labor. Then, too, it is idle to leave out of account the personal and moral elements. The satiated describer of hundreds of species may profess that the question of justice is not pertinent, but justice is, and doubtless will remain, at least equally important with logic. If we do not realize this ourselves we need only observe the enthusiastic amateur who leaves the luxuries of wealth and position to ransack the

world for a new bird, orchid or butterfly. Will he respect a system which legislates away from others an honor he so greatly covets for himself?

There is, perhaps, no sufficient *reason* why we may not make any number of exceptions, set chronologic limits, or otherwise minimize the changes which would attend the thorough application of the principle of priority, under the method of types, but if ultimate uniformity is our aim it will probably prove unwise to include any such modifying principles or rules; unwise, not for botanical, but for human considerations, because there are and will be those to whom the reasons for our exceptions will not appear sufficient; whose regard for the system will demand its emancipation from all artificial trammels, none the less because these are a legacy from a past which recognized carelessly, or not at all, the principles now considered fundamental. A fifty-year concession, for instance, is one of the specious suggestions of the Continental botanists. This apparently simple arrangement would duplicate the difficulties which Dr. Robinson finds in applying the Rochester Rules. Who would decide what constitutes 'use'? Would mention as a synonym in a compiled work like the 'Index Kewensis' be sufficient to save a name from oblivion? What about the numerous genera of fungi, for instance, which have not been rediscovered in the last half century and may not be found again in the next? That the Editor of the Synoptic Flora takes ground against the Rochester Rules because of their incompleteness furnishes weighty evidence that there are but two practical nomenclatorial alternatives, a definite, complete and invariable system elaborated, as far as possible, on the line of a single principle, or a return to the chaos of unguided individual preference. Dr. Robinson must be either an extreme radical or an ultra-conservative, or be open to exactly the same criticism which he visits upon the Rochester Rules. If these Rules lack any of the attributes of a successful system they must be supplied under pain of ultimate oblivion, but those who do not follow the Rules must either go farther, as Prof. Greene and others have recently done, or they must not claim consideration as apostles of

uniformity, at least until they have proposed a system which they are ready to adopt.

The practical incompatibility of usage and uniformity is well illustrated by Dr. Robinson on page 438, where, starting with a recognition of the 'great value of priority,' it is soon found that principles 'should be based upon usage and derive their guiding power by stating, generalizing and correlating usage, and not by defying it.' It may be questioned whether this second system sketched by Dr. Robinson is really a system at all in any practical sense, since it would, as there indicated, leave nomenclature in the same condition as grammar, where between conflicting rules individual taste is the only arbiter. As a system all the complicated parts of such a code would be open to criticism and invite disagreement. Usage has never produced any general or permanent uniformity in manners, government, literature or science, and no reasons are apparent for supposing that it ever will. There could scarcely be a uniform logical system founded upon usage. The idea involves a contradiction of terms, and a plea for usage is, in effect, a plea for anarchy.

To some the Rochester Code recommended itself not so much as a perfect system, but rather as a ground of compromise in the interest of uniformity in nomenclature. As with all compromises, neither the radicals nor conservatives are satisfied, and criticism is possible from both standpoints. The existence of a considerable amount of literature based on the nomenclature of the Rochester Code does not improve the character of that document as a system, but it tends to lessen the force formerly carried by the argument from usage. The event shows already that the chief obstacle to uniformity is not, after all, usage, for that can be changed, but that it lies rather in the elements of human nature noticed above, whereby the earnest systematist is impelled to insist upon considerations of justice and logic which to him appear axiomatic and promise universality. It is becoming certain that systematic workers demand a *system*, and Dr. Robinson emphasizes the demand that the system shall be not only logical and consistent, but that it be complete and definite to the extent that if honestly followed it will produce the uniformity which is at



once its purpose and test. In accordance with this view, it might prove simpler, as well as more honest and logical, to make any desired concessions to usage as exceptions rather than by introducing subsidiary rules of doubtful sanction, such as the fifty-year limit. We could then work with the ideal before us, and such differences as continued to exist would concern particulars merely.

Many of the points treated in the various codes are, relatively, matters of slight importance, and are doubtless capable of being settled for all except the most cantankerous by simple rules or by-laws which might accompany a general platform or code, since in many such matters usage furnishes the only criterion of judgment and no logical or moral principles are involved. Instead of being essentially complicated, however, nomenclature is in reality a very simple matter. Stability and uniformity are the prime requisites, and these can be attained under the binominal system by adhering to the use of the oldest specific name without regard to generic reference, and by confining the application of a generic name to the genus in which its assigned type or first binominal species is included. The complicated and debatable nature of the various codes arises from the neglect of these principles or from attempts at limiting their application, either for avoiding bibliographic labor or in the interests of usage.

O. F. COOK.

U. S. NATIONAL MUSEUM,  
July 27, 1898.

#### SCIENTIFIC LITERATURE.

##### SOME RECENT WORKS ON MECHANICS.

*A Treatise on Analytical Statics.* By E. J. ROUTH. Cambridge, University Press. 8vo., Vol. I., pp. xii + 407, 1891; Vol. II., pp. xii + 224, 1892.

*Traité de mécanique rationnelle.* Par PAUL APPELL. Paris, Gauthier-Villars et Fils. 8vo., Vol. I., pp. vi + 549, 1893; Vol. II., pp. vi + 538, 1896.

*The Elementary Principles of Mechanics.* By A. JAY DU BOIS. New York, John Wiley & Sons. 8vo., Vol. I., pp. x + 231, 1894; Vol. II., pp. viii + 392, 1894; Vol. III., pp. x + 296, 1895.

*Dynamics.* By P. G. TAIT. London, Adam and Charles Black. 1895. 12mo. Pp. xii + 361.

*Elements of Mechanics.* By THOMAS WALLACE WRIGHT. New York, D. Van Nostrand & Co. 1896. 12mo. Pp. viii + 392.

*Applied Mechanics.* By JOHN PERRY. New York, D. Van Nostrand & Co. 1898. 12mo. Pp. viii + 678.

*Ueber die Theorie des Kreisels.* Heft I., Die Kinematischen und Kinetischen Grundlagen der Theorie. Von F. KLEIN und A. SOMMERFELD. Leipzig, B. G. Teubner. 8vo. Pp. iv + 196.

The didactic excellence of the numerous treatises on the principles of mechanics which have appeared in recent years demonstrates an increasing appreciation of the importance of those principles and a progressive effort towards brevity and lucidity in their exposition. The doctrine of energy, now about half a century old, has not only supplied new ways of visualising the familiar and of investigating the unfamiliar in mechanics, but it has also forced us to recognize the omnipresence of mechanical phenomena. The growth of this doctrine and the accompanying developments of the mathematico-physical sciences have furnished, during the past twenty years especially, extensive additions in subject-matter and in applications not hitherto available to writers of works on mechanics. Almost equally important with these additions in the way of material are the improvements in terminology which have been slowly but surely gaining general approval during the present half century. The new points of view afforded by the doctrine of energy, and the critical spirit which has given precision to the terminology, have led also to a revision of the foundations of mechanics. Recent writers devote much space to explanation, illustration and discussion of the so-called axioms of the science; and the trend of current thought is toward the conclusion that most of these axioms are not such at all in the Euclidean sense, but that they are facts of nature which have been discovered by observation. Less stress than formerly is now laid on alleged mathematical proofs of mechanical principles and more attention is given to the phenomena wherein



those principles apply. The old notion that mechanics is merely a branch of applied mathematics is giving way to the more philosophical view that the core of the science consists in its physical principles and that mathematical analysis plays the secondary though wonderfully important rôle of the most effective instrument for investigating mechanical phenomena.

Students who are acquainted with Routh's *Rigid Dynamics* will easily anticipate the character of his *Analytical Statics*; and students not familiar with either should hasten to pursue both works, for in many respects they are the best treatises extant. Their excellence consists in clear exposition of principles, in detailed application of those principles to typical examples, and in elaborate collections of instructive problems.

Volume I. of the work on statics consists of eleven chapters having the following titles: The Parallelogram of Forces; Forces Acting at a Point; Parallel Forces; Forces in Two Dimensions; On Friction; The Principle of Work; Forces in Three Dimensions; Graphical Statics; Centre of Gravity; On Strings; and The Machines. Amongst these the chapter on the principle of work is of most practical importance. That on strings, subject to any forces and including the elastic catenary, is also replete with useful as well as instructive information.

Volume II. consists of three parts, devoted to attractions, including the theory of the potential function; to the bending of rods; and to astatics, respectively. While each of these is a capital contribution, the first is by far the most interesting and important. Though not exhaustive, it is probably the most readable and instructive exposition of the theory of attractions and potential function in the English language. The part devoted to the conditions of equilibrium of bent rods is somewhat novel in a treatise on statics. It would seem rather to belong in a work on the theory of elasticity. Without going into the complex details of the latter, however, the author has considered many of the most important properties of bent and twisted rods, including the case presented by helical springs. The last part presents, in about forty pages, an excellent summary of the

principal theorems which have been discovered in the interesting though not specially useful subject of astatics since its foundation by Moebius in his *Lehrbuch der Statik* in 1837.

For more than one hundred and fifty years the French have held first rank in the production of treatises on mechanics, and their reputation is well sustained in the admirable work of Appell. In his two rather bulky octavo volumes he has given a very comprehensive view of the whole science of rational mechanics. The mode of treatment is distinctly French. One is continually reminded of the clearness and elegance of the great masters, Lagrange, Laplace, Poisson and Poinset. The salient feature of the work is perfection of mathematical method, the point of view of the author being apparently that of the mathematician rather than that of the mechanician.

Volume I. consists of three parts. The first of these is devoted to the theory of vectors, kinematics and the elementary theory of kinetics. The second is devoted to statics and gives a very complete treatment of the subject in all its essential aspects, much space being allotted to the method of virtual displacements. The third part treats of the dynamics of a point and includes a luminous exposition of the principles of d'Alembert, Lagrange and Hamilton.

Volume II. consists of two parts. The first of these treats of the higher methods of Hamilton and Jacobi in application to the dynamics of a point, and the second is devoted to the dynamics of systems in general. The author's exposition of the principles of d'Alembert; of the energy method of Lagrange; of the principle of least action; and of all the elaborate mathematical machinery of Poisson, Hamilton and Jacobi, seems to be more complete and satisfactory than that afforded by any other single work. Every important principle or process is illustrated by application to one or more typical examples, and many unsolved problems are appended to the main chapters of the work. The text bears evidence of careful proof reading, since the number of misprints is very small for a work of so many pages.

The defects of this treatise, though unimportant to all but the novice, are characteristic of

Continental writers on mechanics. They consist in the use of antiquated if not ambiguous terminology, like 'vitesse virtuelle,' 'quantité de mouvement,' 'force vive,' etc.; and in the treatment of mass as a mere mathematical inconvenience to be got out of sight, if not out of mind, as soon as possible.

As may be inferred from the three volumes aggregating upwards of 900 pages, there is room in the work of Professor Du Bois for pretty thorough treatment of the elements of mechanics. A detailed examination of the work will convince one that this room has been well filled. Many parts of the work might have been much condensed and some parts might have been omitted entirely without detriment to an elementary book, but it was the purpose of the author to prepare a text-book which would be of use to students during the whole of their college course and afterwards as a work of reference. This purpose, it must be said, has been very well executed, and the work will prove exceedingly useful to teachers and professional readers as well as to students.

The plan of the work is in accordance with the divisions of the science adopted by Thomson and Tait in the *Natural Philosophy*; the first part being devoted to kinematics, and the last two to dynamics, that is, to statics and kinetics respectively. The development of the fundamental principles is systematic and logical, and an invaluable feature of the volumes is found in the large number of numerical examples fully worked out. By means of typographical devices the author appeals to all classes of readers, the paragraphs in large type forming an abridged course, the articles in small type being for advanced students, and articles involving the use of the calculus being set off by brackets. Italics and full-face type are also used with a freedom which seems Teutonic rather than English in its tendencies, and many readers will wonder how statements which are already admirably clear and intelligible are rendered more so by those pictorial devices.

The volumes devoted to kinematics and statics are very full of well arranged and digested matter for an elementary work, the volume on statics containing also four chapters

(158 pp.) on retaining walls, elasticity of materials, theory of flexure and the continuous girder, respectively. The volume on kinetics is likewise quite complete, all but one short chapter on the gravitational potential being occupied with what may be called pure theory.

Amongst many commendable features of the work of Professor Du Bois special mention should be made of the clearness of definition and the precision of terminology which prevail throughout the volumes. In these respects the work is on the whole especially satisfactory. The only exceptions we have noted are in Chapter VIII. of Vol. III., wherein the potential as defined by equation (1) does not appear to have the dimensions assigned to it in problem (11). In the same chapter also, p. 113, a well known theorem of Gauss is attributed to Laplace; while on pp. 114 and 115 Poisson's extension of Laplace's theorem is referred to without explanation of Laplace's theorem itself.

Professional and unprofessional students who have read Professor Tait's profound article on mechanics in the last edition of the *Encyclopædia Britannica* welcome the reprint of that article with additions in the handy text-book form presented by the Messrs. Black. Some modifications of the original article have been made in this reprint, and the subjects of attractions, hydrostatics, hydrokinetics and waves have been incorporated as additions. The result is a treatise on dynamics which for thought-promoting information per unit area is equalled only by the *Natural Philosophy* of Thomson and Tait. Every student will feel a regret that the author did not enlarge the work much beyond its present limits. This regret is especially keen with respect to Chapter V., wherein the methods of Lagrange and Hamilton are all too briefly developed. But the author anticipated and answered this criticism. In his preface he says: "One obvious objection may be made to many parts of this book—undue brevity. It was inevitable, when much had to be compressed into moderate space; yet, at the worst, is not brevity, if it but convey its message, transcendently preferable to prolixity?"

The work of Professor Wright is a completely rewritten edition of his book on mechanics published a few years ago. A larger page and

larger type have been used, and the work is in every respect an improvement over the earlier edition. The scope of the book is limited to coplanar kinematics and dynamics, and it seems remarkable that so much of the groundwork of the science is covered in spite of that restriction. The author has also limited himself in the use of the calculus, the book being so arranged as to form a consecutive elementary course without resort to that branch of mathematics which is still a mystery to many well developed minds. On the other hand, by such limited use of the calculus he seeks to prevent the student 'from thinking, as is often the case, that there is a kind of mechanics called elementary, another analytical, a third theoretical, and so on.' For the average student, it must be admitted, this type of book is more readable than any other, and we can heartily recommend Professor Wright's book as one of the freshest, most interesting and most instructive of the type. In the old days, when all students of some colleges were compelled to pursue mechanics, it was commonly considered a 'dismal science.' Saxe, in his *Reflective Retrospect*, says:

"I recollect those harsh affairs,  
The morning bells that gave us panics.  
I recollect the formal prayers  
That seemed like lessons in mechanics."

But no one can read Professor Wright's book without being interested at least in the historical references and apt quotations he has worked in along with the formal parts of the science. Even the ponderous gravity of John Milton has to submit to a sly dig from the wily mechanician. Witness this conclusion from Milton's data:

"Men called him Mulieiber: and how he fell  
From heaven they fabled, thrown by angry Jove  
Sheer o'er the crystal battlement: from morn  
To noon he fell, from noon to dewey eve,  
A summer's day: and with the setting sun  
Dropt from the zenith like a falling star,  
On Lemnos th' Ægean isle."

"Taking the summer's day fifteen hours, show that the distance of Lemnos isle from heaven is about one-fourth of the distance to the moon."

Of a radically different type from any other work noticed in our list is the text-book on

applied mechanics of Professor Perry. It is also quite different from the standard works on the subject by Rankine, Weisbach and others. In fact, it is a unique work, full of information as an egg is full of meat, and written in a style which is very lively in comparison with the sedate models set by previous writers. As stated on the title-page, the book is intended to be 'A treatise for the use of students who have time to work experimental, numerical and graphical exercises illustrating the subject.' As to the qualifications of a reader taking up the work the author says in his preface: "I should like to think that, before a student begins the part in small type, he has worked through Thomson and Tait's small book on *Natural Philosophy*, and that he has read the early part of my book on 'The Calculus for Engineers.'" The vigorous way in which the views of the author are set forth may be inferred from the following quotations from the introductory chapter:

"When we think of what goes on under the name of teaching we can almost forgive a man who uses a method of his own, however unscientific it may seem to be. Nevertheless, it is not easy to forgive men who, because they have found a study interesting themselves, make their students waste a term upon it, when only a few exercises are wanted—on what is sometimes called the scientific study of arithmetic, for example, or of mensuration."

"In our own subject of Applied Mechanics there are teachers who spend most of the time on graphical statics, or the graphing of functions on squared paper, or the cursory examination of thousands of models of mechanical contrivances. One teacher seems to think that applied mechanics is simply the study of kinematics and mechanisms; another, that it is the simple exercise work on pure mechanics; another, that it is the breaking of specimens on a large testing machine; another, that it is trying to do in a school or college what can only be done in real engineering works; another, that it is mere graphics; another, that it is all calculus and no graphics; another, that it is all shading and coloring and the production of pretty pictures without center lines or dimensions. Probably the greatest mistake is that of



wasting time in a school in giving information that one cannot help picking up in one's ordinary practical work after leaving school."

"In teaching beginners it is well to start on the assumption that students already possess the notions of the differential and integral calculus, and it is the teacher's duty to put before them the symbols used in the calculus at once. It is surely much better to do this than to evade the calculus in the fifty usual methods which we sometimes see adopted."

The book contains thirty chapters, followed by an appendix of useful tables, including 4-place logarithms and anti-logarithms, and a full index. Every chapter is replete with useful information, and most topics are treated in ways that are refreshing by reason of the novelty of method and the incisive language of the author. We may not in all cases accept his views or approve his style, but there is not a dull page in the text, and his views and style are everywhere entertaining and instructive. There is much new matter in the book, and the numerous illustrations (371 of them) are in general excellent, many of them exhibiting apparatus designed by the author and now published apparently for the first time. To teachers, to engineers and to readers of mechanics, as well as to students, this book cannot be too highly commended.

During the hundred years ending with the first half of the present century the most important contributions to mechanical science were made by writers who were alike eminent as mathematicians and as mechanicians. Such were the great masters Lagrange, Laplace, Poisson, Cauchy, Gauss, Dirichlet, Lamé, etc. Since that time, however, the mathematicians and mechanicians have parted company to a great extent and their diverging paths have presented little in common. Whether this fact is to be regretted or not must be left for the historians of our times to decide. In the meantime each according to his bias will rejoice that pure mathematics is not, or that pure mechanics is, deeply concerned with things material. Those subject to the latter bias will rejoice that the prestige of the Göttingen school of mathematicians is maintained by the presence of Professor Klein in the field of mechanics.

The volume before us is an elaboration, through the aid of Dr. Sommerfeld, of Professor Klein's lectures at the University of Göttingen. It does not pretend to be a systematic treatise, but, very appropriately, assuming a general knowledge of mechanics on the part of the reader, proceeds to discuss, in considerable detail, the typical problem of the top in its kinematical, kinetic and mathematical aspects.

The book is divided into three chapters. The first of these is occupied with the kinematical principles of the problem, and the systems of coordinates required to specify the motion of a top are elaborately considered. The most important novelty of the work in this part consists in the very natural introduction of complex numbers and quaternions, about one-fifth of the chapter being devoted to the latter.

The second chapter considers the principles of kinetics and develops the formulas applicable to the notion of a free mass and to the rotation of a rigid body, special emphasis being given to the theory of impulses. The last chapter is devoted to Euler's equations of rotation and to their integration; and a promise is indicated that the following volumes may treat, among other applications, the important problem of variations of terrestrial latitudes. Both of these chapters present much that is novel with respect to matter and mode of presentation, leading us to await with interest the appearance of subsequent volumes.

In one respect the authors are, we think, open to a criticism which will apply also to many other Continental writers on mechanics. Since the appearance of Thomson and Tait's *Natural Philosophy* and Maxwell's *Matter and Motion*, progress in the ideas as distinguished from the methods of mechanics is attributable largely, if not chiefly, to the decapitation of the numerous 'forces' of the science other than the one which is the product of mass and acceleration. It seems like a step backwards, therefore, to encounter in this capital work some new species of force in addition to many of the species which have long been fossil in the best English terminology. Clearness of physical principles would seem to exclude all such terms as *Drehkraft*, *Schiebekraft*, *Stofskraft*, etc., along with *lebendige Kraft*. We shall hope



that future volumes of the authors will follow English terminology more closely, since, without regard to race prejudice, it appears vastly superior to that of other languages. The lack of a generally accepted precise terminology in French and German appears to have led the authors to attribute a similar indefiniteness to English terms wherein such defect does not exist. Thus, on page 81, they say: "Gewöhnlich wird in den englischen Büchern statt Impuls das etwas farblos wort momentum benutzt; die Komponenten des Impulses heissen dan 'the moments of momentum.' (!)"

R. S. W.

*An Illustrated Flora of the Northern United States, Canada and the British Possessions, from Newfoundland to the parallel of the southern boundary of Virginia, and from the Atlantic ocean westward to the 102d meridian.* By NATHANIEL LORD BRITTON, PH.D., and HON. ADDISON BROWN. Vol. III., Apocynaceae to Compositae; Dogbane to Thistle. New York, Charles Scribner's Sons. 1898. Large 8vo. Pp. xiv + 588.

A little less than two years ago (August 22, 1896) the first copies of Volume I. of this important work were distributed; less than a year later (June 15, 1897) a copy of Volume II. reached the writer; now (July 5) the third and last volume is at hand. When we bear in mind that these three volumes include descriptions of 4,162 species, and that every one of these is illustrated by outline drawings, one-half to three-fourths natural size, with many additional figures somewhat enlarged, we are able to realize the great amount of labor involved in their preparation and publication. The authors and publishers are to be congratulated upon such prompt completion of this work, whose value is greatly increased by the fact that so short a time has elapsed between the appearance of its volumes.

It is not necessary here to speak of the peculiarities of these volumes, since every working botanist in this country is familiar with them. The modern nomenclature, following the famous 'Rochester Rules,' and the modern sequence of families, following the system of Engler and Prantl, distinguish this from every other syste-

matic work on the plants of North America. It follows that those who do not like the Rochester Rules will not like this book, nor will those who persistently adhere to the Candollean sequence of families. However, it is inevitable that one result of its publication will be that the number of those actively opposing these modern features will rapidly grow less. It will soon be much easier to follow the modern innovations along the plain highway here made than to continue in the less and less frequented paths of the conservatives.

The General Key to the Orders and Families will be helpful, not only as a key, but also as affording a synoptical view of the system adopted. While necessarily keys are all much alike, this one shows in many ways the influence of the modern ideas in regard to plants. Here and there a slip occurs, and now and then there is a patch of old cloth used in the new garment. But these are to be expected, and they are not serious blemishes. In a second edition, for example, we may have a correction on page viii of the statement which makes embryo-sac synonymous with macrospore, and of the description of the leaves of Isoetaceae as 'tubular.'

Having accomplished so good a work the authors now owe it to the botanical public to bring out a small, thin-paper edition, without illustrations, so that all the descriptions may be brought within the limits of a small book. If the publishers will then give it a flexible binding, with narrow page margins, they will make a most useful book, which will be a fine adjunct to the fine large three-volume edition now before us.

CHARLES E. BESSEY.

THE UNIVERSITY OF NEBRASKA.

#### SCIENTIFIC JOURNALS.

THE contents of the *American Journal of Science* for August are as follows: 'Jurassic Formation on the Atlantic Coast—Supplement.' By O. C. MARSH. 'Mineralogical Notes.' By C. H. WARREN. 'Origin and Significance of Spines—A Study in Evolution.' By C. E. BEECHER. 'Prehistoric Fauna of Block Island, as indicated by its Ancient Shell-Heaps.' By G. F. EATON.

'Registering Solar Radiometer and Sunshine Recorder.' By G. S. ISHAM. 'Tertiary Elevated Limestone Reefs of Fiji.' By A. AGASSIZ. 'Iodometric Determination of Molybdenum.' By F. A. GOOCH and J. T. NORTON, JR. 'Sölvbergite and Tinguaita from Essex County, Mass.' By H. S. WASHINGTON. 'Occurrence of Native Lead with Roehlingite, Native Copper and other Minerals at Franklin Furnace, N. J.' By W. M. FOOTE. 'Position of Helium, Argon and Krypton in the Scheme of Elements.' By W. CROOKES.

THE *American Naturalist* for July opens with the first part of an article by Mr. C. R. Eastman on the 'Dentition of Devonian Pteryodontidae.' Mr. Outram Bangs contributes a list of the mammals of Labrador supplementary to that prepared by Mr. A. P. Low. There are short articles on variations in the number of ray-flowers in the White Daisy by Mr. F. C. Lucas and on the development of Mantis by Mr. T. D. A. Cockerell.

#### SOCIETIES AND ACADEMIES.

##### ENGELMANN BOTANICAL CLUB.

The Club met July 14th, ten members present.

Mr. C. H. Thompson discussed the distribution, pollination and dissemination of North American *Lemnaceæ*. In opposition to the current view of wind pollination, Mr. Thompson adopts Ludwig's theory of insect pollination as most consistent with *Lemna* structure. Local dissemination is by means of currents of water and wind and by aquatic insects. Fronds are carried to greater distances by adhering to water fowls.

Dr. Joseph Grindon presented a list of plants observed by him in Forest Park with their time of flowering.

Mr. J. B. S. Norton mentioned finding *Helianthus petiolaris*, *Sesbania macrocarpa*, *Salsola Kali* *Tragus* and other plants introduced about East St. Louis, and *Stenanthium robustum* in Forest Park, where it was collected by Dr. Engelmann many years ago, but west of the range usually given for that species. He also spoke briefly of Darwin's recent observations on stomata.

The meeting of July 28th was devoted to informal talks on botanical topics of interest to the members present.

J. B. S. NORTON,  
Acting Secretary.

##### ACADEMY OF NATURAL SCIENCES, OF PHILADELPHIA, JULY 26, 1898.

MR. WILFRED H. HARNED, alluding to the report that clay was eaten in certain places in the Southern States, read a letter from a correspondent intimating that the practice could not be met with there.

MR. BENJAMIN SMITH LYMAN remarked that on the Island of Yesso he had been shown a white clay which was said to be eaten by the natives.

PROFESSOR HENRY A. PILSBRY exhibited a number of shells of the genus *Cerion*, illustrating the fact that each of the Bahama Islands has its own peculiar species. He had been told that in Cuba the habitats of the species of this genus are almost as well defined as are those of the islands. No one species is generally distributed over the entire island nor along any great extent of sea-board. Specimens of *Cerium incanum* from the Florida Keys were also exhibited. The speaker suggested that an examination of the Keys would probably reveal a similar definition of local forms.

A paper entitled 'A New Land Snail from Clarion Island,' by Henry A. Pilsbry, was presented for publication.

EDW. J. NOLAN,  
Secretary.

#### NEW BOOKS.

*L'Année Psychologique.* ALFRED BINET. Paris, Schleicher Frères. 1898. Quatrième Année. Pp. 849.

*Electricity and Magnetism.* FRANCIS E. NIPHER. St. Louis, J. L. Boland. 1898. 2d Edition. Pp. xi + 430.

*Special Report on the Beet-sugar Industry of the United States.* Washington, Government Printing Office. 1898. Pp. 239.

*The Birds of Indiana.* AMOS W. BUTLER. From the 22d Report of the Department of Geology and Natural Resources of Indiana. 1897. Pp. 516-1187.

# SCIENCE

EDITORIAL COMMITTEE: S. NEWCOMB, Mathematics; R. S. WOODWARD, Mechanics; E. C. PICKERING, Astronomy; T. C. MENDENHALL, Physics; R. H. THURSTON, Engineering; IRA REMSEN, Chemistry; J. LE CONTE, Geology; W. M. DAVIS, Physiography; O. C. MARSH, Paleontology; W. K. BROOKS, C. HART MERRIAM, Zoology; S. H. SCUDDER, Entomology; C. E. BESSEY, N. L. BRITTON, Botany; HENRY F. OSBORN, General Biology; C. S. MINOT, Embryology, Histology; H. P. BOWDITCH, Physiology; J. S. BILLINGS, Hygiene; J. MCKEEN CATTELL, Psychology; DANIEL G. BRINTON, J. W. POWELL, Anthropology.

FRIDAY, AUGUST 19, 1898.

## CONTENTS:

<i>Doctorates Conferred by American Universities for Scientific Research</i> .....	197
<i>The Beginnings of Laboratory Teaching in America:</i> PROFESSOR FRANK P. WHITMAN.....	201
<i>Hydraulic Illustration of the Whatestone Bridge:</i> PROFESSOR WILLIAM HALLOCK.....	206
<i>The Echelon Spectroscope:</i> DR. C. RIBORG MANN.....	208
<i>The Relation of Science Education in the Secondary Schools to that in the College and the University:</i> PROFESSOR PAUL C. FREER.....	210
<i>Lacoe Collection in the National Museum</i> .....	213
<i>A New Name for the Georgia Old Field Mouse:</i> OUTRAM BANGS.....	214
<i>Botanical Notes:—</i>	
<i>Seeds and Very Low Temperatures; The Scientific Work in the Department of Agriculture; Botanical Papers in the Nebraska Academy of Sciences; The Ovary of Opuntia:</i> PROFESSOR CHARLES E. BESSEY.....	215
<i>Current Notes on Anthropology:—</i>	
<i>On Pygmy Races; Unsolved Problems of Anthropology; About the Hittites:</i> PROFESSOR D. G. BRINTON.....	217
<i>Scientific Notes and News</i> .....	218
<i>University and Educational News</i> .....	223
<i>Discussion and Correspondence:—</i>	
<i>Observations on Blue Jays:</i> DR. HIRAM M. STANLEY.....	223
<i>Scientific Literature:—</i>	
<i>Milhaud's La certitude logique et Le rationnel:</i> PROFESSOR J. H. HYSLOP. <i>Duss on the Flore phanérogame des Antilles Françaises</i> .....	224
<i>Scientific Journals</i> .....	225
<i>Societies and Academies:—</i>	
<i>The American Association for the Advancement of Science</i> .....	226

## DOCTORATES CONFERRED BY AMERICAN UNIVERSITIES FOR SCIENTIFIC RESEARCH.

The development of the American university during the past twenty-five years may perhaps be regarded as the great achievement of the nation. The foundations laid at Harvard and at Johns Hopkins within the life-time of those students now profiting from them have been built upon, until we have now a score of universities, as places for research, equal to Oxford, and half a dozen rivalling those of Germany. The American college, though founded upon the English system, was of native growth, and the university based upon this college, though influenced by German methods, is distinctly national, while, at the same time, our different institutions show a marked individuality. The American university is definitely a place for research, where both teachers and students are engaged in research or in learning the methods of research. The results of the work of the students is in large measure summarized by the theses for the doctorate, and it is interesting to know what is the outcome of the past year's research.

It appears, from a somewhat careful enquiry, that eighteen leading universities conferred the Ph. D. degree on 234 candidates. The degree was not given last year by Indiana, Illinois, Kansas, Texas, Colorado, Missouri, Tulane or the Catholic University

of America. The doctorates conferred by the several universities are classified in the accompanying table:

Universities.	Humanities.	History and Economics.	Sciences.	Total.
Chicago.....	12	12	12	36
Yale .....	19	4	11	34
Johns Hopkins .....	11	3	19	33
Harvard .....	12	3	11	26
Pennsylvania .....	9	7	8	24
Columbia .....	7	5	10	22
Cornell .....	7	1	11	19
Clark.....			12	12
Michigan.....	6	1		7
New York.....	4		1	5
Wisconsin .....	2	1	2	5
Bryn Mawr.....	1	1		2
Leland Stanford, Jr.....			2	2
Nebraska .....			2	2
Brown.....			1	1
California.....			1	1
Columb an.....			1	1
Minnesota.....	1			1
Total number of Ph.D. degrees conferred.....	91	38	105	234

It is gratifying for the scientific student to note that 105 degrees were conferred in the sciences. The number of degrees in science surpasses or approximately equals the number in the humanities in all the universities except Yale, Michigan and New York, and in nearly all cases exceeds the number in history and economics. The universities vary somewhat, the sciences being relatively favored at Johns Hopkins, the humanities at Yale, and history and economics at Chicago. Princeton conferred one D. Sc., and is not included in the table. The standards of the universities vary somewhat, and it is unfortunate that in certain cases the theses are not printed. It is a sign of progress that the Ph. D. degree *causa honoris* was apparently not given last year by any important institution.

There are probably not as many as one thousand men of science in the United States

engaged in original research, and the forces are consequently greatly strengthened by one hundred recruits—not including those from Germany and elsewhere—in a single year. The distribution of these students among the different sciences was as follows:

Chemistry.....	27
Psychology.....	18
Zoology.....	12
Mathematics.....	11
Physics.....	11
Botany.....	11
Geology.....	6
Physiology.....	4
Astronomy.....	3
Anthropology.....	2

The names of those on whom the doctorate was conferred for work in these sciences, and the subjects of their theses, are as follows:

#### THE JOHNS HOPKINS UNIVERSITY.

Cleveland Abbe, Jr.: Geology, Some Maryland Rivers and their Development: A Contribution to the Physiographic History of Maryland.

Howard Bell Arbuclle: Chemistry, A Redetermination of the Atomic Weights of Zinc and Cadmium.

Charles Gilpin Cook: Chemistry, Some Double Halides of Tin with the Aliphatic Amines and with Tetramethylammonium.

Frederick Henry Duryea Crane: Chemistry, A Contribution to the Knowledge of Tellurium.

Gilman Arthur Drew: Zoology, The Anatomy, Habits and Embryology of *Yoldia limatula*, Say.

John Eiesland: Mathematics, On a Certain Class of Functions with Line-Singularities.

Charles Wilson Greene: Physiology, On the Relations of the Inorganic Salts found in Blood to the Automatic Activity of a Strip of Cardiac Muscle.

James Graham Hardy: Mathematics, On One-Variable Displacements in a Space of Four Dimensions, and on Curves of Triple Curvature.

Caleb Notbohm Harrison: Physics, The Arc-Spectra of the Elements Lanthanum, Vanadium, Zirconium.

William App Jones: Chemistry, A Contribution to the Knowledge of Dicarboxyl Cuprous Chloride.

Arthur Gray Leonard: Geology, The Basic Rocks of Northeastern Maryland and their Relation to the Granite.

Charles Elwood Mendenhall: Physics, A Bolomet-



ric Study of the Spectrum of an Absolutely Black Body between the Temperature of  $300^{\circ}$  to  $1100^{\circ}$  Centigrade.

Samuel Alfred Mitchell: Astronomy, I. The Theory of the Concave Grating; II. Use of the Concave Grating in Stellar Spectroscopy.

Cleophas Cisney O'Harra: Geology, The Geology of Alleghany County, Maryland.

Thomas Dobbin Penniman: Physics, Some new Methods for the Determination and Comparison of Self Inductance, Mutual Inductance and Capacity, together with some Actual Measurements.

Edward Rhoads: Physics, The Effect of the Fibrous Structure of Sheet Iron on the Changes in the Length accompanying its Magnetization.

Garnett Ryland: Chemistry, A Contribution to the Study of Liquid Mixtures of Constant Boiling Point.

Charles William Waidner: Physics, A Recalculation of the Mechanical Equivalent of Heat.

Albert Francis Zahn: Physics, Determination of the Resistance of the Air at Speeds of 200 to 500 Miles an Hour, with Notes on two New Methods of Measuring Projectile Velocities inside and outside the Gun.

#### UNIVERSITY OF CHICAGO.

Samuel Jackson Holmes: The Early Development of *Planorbis trivolvis*.

Henry Chandler Cowles: An Ecological Study of the Sand Dune Flora of Northern Indiana.

Herbert Ellsworth Slaughter: The Cross Ratio Group of 120 Quadratic Cremona Transformations of the Plane.

William L. Bray: The Xerophytic Flora of the Texan Plains.

Otis William Caldwell: Morphology of Lemna, with Ecological Notes.

Otto Knute Olaf Folin: On Urethanes.

Edwin Sheldon Johonnot, Jr.: Thickness of the Black Spot in Liquid Films.

Herbert Newby McCoy: On the Hydrochlorides of Carboxyphenylimide Derivatives.

William Dayton Merrell: Contribution to the Life History of Silphium.

Amy Eliza Tanner: Imagery, with Special Reference to Association of Ideas.

William Douwes Zoethout: The Physiological Effects of High Temperatures and Lack of Oxygen upon Lower Organisms.

#### CLARK UNIVERSITY.

Frederick C. Ferry: Mathematics, Geometry on the Cubic Scroll of the First Kind.

Ernest W. Rettger: Mathematics, On Lie's Theory of Continuous Groups.

Benjamin F. Sharpe: Physics, An Instrument and Method for the Measurement of Sound.

Frederick L. Burk: Psychology, From Fundamental to Accessory in Nerve-Muscle Structure and Function.

F. E. Bolton: Psychology, Some Hydro-psychoses.  
Linus W. Kline: Psychology, Migration vs. Love of Home.

J. Richard Street: Psychology, A Genetic Study of Immortality.

Daniel E. Phillips: Psychology, The Teaching Instinct.

F. W. Colegrove: Psychology, Memory as a Function of Age.

E. W. Bohannon: Psychology, Motor-Education.  
Cephas Guillet: Psychology, Instincts in Children and Animals Compared.

H. S. Curtis: Psychology, Inhibition Experimentally and Theoretically Considered.

#### CORNELL UNIVERSITY.

Samuel Jackson Barnett: On the Surface Tension of Liquids under the Influence of Electrostatic Induction.

Isaac Madison Bentley: The Qualitative Fidelity of the Memory Image.

Hector Russell Carveth: Single Differences of Potential.

Charles Worthington Comstock: The Application of Quaternions to the Analysis of Internal Stress.

Benjamin Minge Duggar: Studies on the Morphology of the Gametophyte, and Development of the Sporangium, in some Angiosperms.

Eleanor Acheson McCulloch Gamble: The Applicability of Weber's Law to Smell.

Cyril George Hopkins: The Chemistry of the Corn Kernel.

James George Needham: A Genealogic Study of Dragon-fly Wing Venation.

Stella Emily Sharp: Individual Psychology.

John Ferguson Snell: Potassium Chloride in Aqueous Acetone.

#### HARVARD UNIVERSITY.

Frank Watts Bancroft: Zoology and Physiology, Ovogenesis in *Distaplia* with Remarks on other Species.

Harry Yandell Benedict: Celestial Mechanics, The Variation of Latitude.

William Burdelle Bentley: Organic Chemistry, Tribrombenzol and Derivatives.

Joseph William Blankinship: Botany, Isolation as a Criterion of Species.

Donald Frank Campbell: Mathematics, On Linear Differential Equations of the Third and Fourth Orders, in whose Solutions exist certain Homogeneous Relations.

Allerton Seward Cushman: Chemistry, The Atomic Weight of Nickel.

James Edwin Lough : Psychology, The Intensity of Sensation : An Experimental Essay in Physiological Psychology.

Frank Russell : Somatology, A Study of a Collection of Eskimo Crania from Labrador, with Observations on the prevailing System of Craniometry.

Charles Augustus Soch : Organic Chemistry, Action of Sodium Nitromalonic Aldehyde on Ketones and Ketone Acids.

Leon Mendez Solomons : Psychology, The Fusion of Touch Sensations.

Frederick Clayton Waite : Zoology, The Structure and Development of the Antennal Glands in *Homarus americanus* Milne-Edwards.

#### YALE UNIVERSITY.

Alice Hopkins Albro : Chemistry, The Original and Chemical Relationship of some Products of Proteolytic Cleavage.

Martha Austin : The Estimation of Manganese in Analysis.

Bayard Barnes : Chemistry, Investigations in Organic Chemistry.

George Francis Eaton : The Prehistoric Fauna of Block Island, as indicated by its Ancient Shell Heaps.

Harry Ward Foote : Investigations in Chemistry and Mineralogy.

Yandell Henderson : Chemico-Physiological Studies on the Derivatives of the Proteids.

George Tucker Sellow : On the Complex Number.

George Pratt Starkweather : The Thermodynamic Relations for Water Steam.

Wendell Melville Strong : On the Necessity of Continuity in Euclid's Geometry.

Willard Gibbs Van Name : On the Embryology of a Marine Planarian.

Jacob Westlund : Some new Equations of Transformation.

#### COLUMBIA UNIVERSITY.

Gary Nathan Calkins : Zoology, Mitosis in *Noctiluca miliaris* and its Bearing on the Nuclear Relations of the Protozoa and Metazoa.

Wilber Dwight Engle : Chemistry, Some Thiocyanates.

Abel Joel Grout : Botany, A Revision of the North American Isoetaceae and Brachytheciae.

Marshall Avery Howe : Botany, The Hepaticae of California.

Wilfrid Lay : Psychology, Mental Imagery.

Albert Prescott Matthews : Physiology, The Structural Changes of the Pancreas Cell, with some General Considerations on Cell Metabolism.

John Alexander Matthews : Chemistry, On the Action of Fatty Nitrils upon Aromatic Acids.

Per Axel Rydberg : Botany, A Revision of the North American Potentillae.

Frank Schlesinger : Astronomy, The Præsepe Group ; Measurement and Reduction of the Rutherford Photographs.

Edward Lee Thorndike : Psychology, Animal Intelligence.

#### UNIVERSITY OF PENNSYLVANIA.

Elizabeth Allen Atkinson : Metal Separations by Means of Hydrobromic Acid Gas: Indium in Tungsten Minerals.

Frederick Ehrenfeld : A Study of the Igneous Rocks of York Haven and Stony Brook, Pa., and their Accompanying Formations.

William Mason Grosvenor, Jr. : Electrolytic Reductions.

Harold Heath : The Development of Ischonochiton.

Victor Lenher : The Atomic Mass and Derivatives of Selenium.

Joseph Merritt Matthews : Derivatives of the Tetrahalides of Zirconium, Thorium and Lead.

Edward Anson Partridge : On the Mathematical Theory of the Geometric Chuck.

George William Sargent : The Quantitative Determination of Boric Acid in Tourmaline.

George Edward Thomas : The Atomic Mass of Tungsten and the Preparation of Sodium Pertungstate by means of the Electric Current.

#### LELAND STANFORD, JUNIOR, UNIVERSITY.

George Clinton Price : Development of the Excretory Organs of a Myxinoïd, *Bdellostoma Stouti*.

Walter Robert Shaw : Observations on the Fertilization of the Egg cell in the genus *Onoclea*.

#### UNIVERSITY OF NEBRASKA.

Frederic Edward Clements : The Phyto-geography of Nebraska.

Albert Luther Candy : A General Theorem relating to Transversals and its Consequences.

#### UNIVERSITY OF WISCONSIN.

Ernest Robertson Buckley : Geology, The Building and Monumental Stone of Wisconsin.

Samuel Weidman : Geology, The Geology of the pre-Cambrian Igneous Rocks of the Fox River Valley, Wisconsin.

#### BROWN UNIVERSITY.

Frederic Slocum : The Harmonic Analysis of the Tides and a Discussion of the Tides of Narragansett Bay.

#### BRYN MAWR COLLEGE.

Esther F. Byrnes : Morphology, The Maturation and Fertilization of the Egg of Limax.

## UNIVERSITY OF CALIFORNIA.

Willis Linn Jepson: Botany, Flora of Western Middle California.

## COLUMBIAN UNIVERSITY, WASHINGTON, D. C.

Cabell Whitehead: Chemistry, A Study of the Tellurides: their Formation and Chemical Properties.

## NEW YORK UNIVERSITY.

William Lawrence A. Dalton: Psychology, Experimental Studies in Association and Memory.

THE BEGINNINGS OF LABORATORY TEACHING IN AMERICA.

THE American Association for the Advancement of Science celebrates this year its fiftieth anniversary. The epoch thus commemorated is notable in more than one way as that of a scientific awakening in this country. The foundation of the Association; the welcome given to Agassiz, whose first lectures were delivered at the Lowell Institute in 1846; the enthusiasm greeting the astronomical pilgrimages of O. M. Mitchell, to quote but a few out of many indications, show an aroused public sentiment with regard to natural science.

In no way is this movement more striking than in the effect upon scientific teaching in the colleges. For many years this had been nearly at a standstill. The methods seem to have been everywhere much the same. Instruction was by text-book and lecture. The lectures were illustrated, the illustrations of the spectacular sort. The magnitude or brilliancy of a lecture experiment was often as highly valued as its actual illustrative character. Thus the compound blowpipe and the mammoth batteries of Robert Hare were eagerly welcomed by Benjamin Silliman, with a keen appreciation of effects, and he points with a just pride to the hugeness of the electromagnet constructed for Yale College under the direction of Joseph Henry.

The Yale catalogue of 1822 announces that "The junior class attends a course of experimental natural philosophy; and the

senior class the courses in chemistry, mineralogy, geology and the principles of natural philosophy."

All these courses were under the charge of Professor Silliman, and the above formula remains practically unchanged in the catalogues for upwards of twenty-five years, or until after the founding of the Scientific School. Other college catalogues, Amherst, Bowdoin, Brown, Harvard, Princeton, tell a similar story.

At Dartmouth, as at Yale, the necessity of providing for medical students required the maintenance of a somewhat high scientific standard, and a brief summary of the progress of chemical teaching at Dartmouth probably gives an idea of the best opportunities of the day.

Lectures on chemistry were given at Dartmouth before the opening of the present century, the lecturer holding the double title—varying somewhat from year to year—of professor (or lecturer) on chemistry and medicine.

In 1820 James Freeman Dana is professor of chemistry, mineralogy and the application of science to the arts; in 1822 professor of chemistry, mineralogy, pharmacy and legal medicine. The number of departments under control of one man sufficiently indicates the paucity of the courses.

In 1825 Professor Dana published an 'Epitome of Chemical Philosophy.' This appears to be the first mention of a text-book in chemistry, though these were probably in use before. In 1833 Turner's Chemistry was used, and then successively Kane's, Fownes' and Silliman's. Through much of this period a small fee is charged students attending the chemical lectures, which are given in connection with the text-book.

In the catalogue for 1851-52 the statement is made that 'the chemical laboratory is amply furnished with apparatus and chemicals for illustration of lectures in that



department.' The founding of the Chandler Scientific School at this period put the teaching of science on an entirely different plane.

Like conditions prevailed everywhere. The spirit of investigation showed itself actively enough in some directions, but it does not seem to have impressed itself upon the teaching, and, in fact, was not generally connected with the colleges. As is to be expected in a new country, it expended itself mainly in exploration, in geological, botanical and ornithological collection, and the school of wandering naturalists, connected, perhaps, chiefly with Philadelphia, would furnish an interesting chapter in the history of science.

What research there was in chemistry and physics, not yet differentiated, was largely in the hands of the medical profession, and here again the interest centers in the city of Philadelphia, partly on account of the presence in that city of the ingenious Robert Hare; partly because of the tendencies of the University and medical school; partly on account of the scientific traditions of the city, dating from the time of Franklin and his associates.

Many of the early contributors to 'Silliman's Journal' were physicians, with Robert Hare at their head, both in reputation and apparently in original ability. He made one addition of the first importance to the resources of the chemical investigator by his invention of the compound blowpipe, and in his two forms of voltaic cell, the 'deflagrator' and the 'calorimotor,' he foresaw dimly that fundamental law of the electric current now connected with the name of Ohm. Dr. Hare filled the chair of chemistry in the medical school of the University of Pennsylvania, and his lectures were brilliantly illustrated and of high repute.

In the history of the teaching of science, as distinguished from that of active research, the most prominent figure in the

first half of the nineteenth century is not at Philadelphia, but New Haven, and its characteristics are not original power, but enthusiasm for teaching, administrative ability, social influence, sound and clear judgment.

Benjamin Silliman was graduated from Yale in 1796, with high honor and a reputation for sound scholarship. It does not appear that he had distinguished himself in scientific studies—the opportunities of specializing in that direction were not great at the Yale of that day—and he studied law after graduation from college, combining with his studies the work of a college tutor. He was admitted to the bar in 1802. In this year a chair of chemistry and geology was established in the College and offered to young Silliman, who, at the solicitation of President Dwight, forsook the law and accepted the position.

He spent two years in fitting himself for his work, going first to Princeton, where, it is said, he first saw experiments in chemistry performed; then, after a little, to Philadelphia, remaining there till 1804. In 1805 he was abroad for nearly a year, studying and collecting apparatus and specimens. Entering upon his work, he continued in charge of his department for fifty years. His acute insight soon perceived that a pressing need of the science of the country was an organ of intercommunication, and in 1818 he founded the *American Journal of Science*, better known for half a century as 'Silliman's Journal.' This venture involved at first considerable pecuniary sacrifice, but became self-supporting in about four years. Its influence was very wide. In 1822 Silliman writes: "Its most extensive patronage is derived from the city of Philadelphia, which takes more copies than any other community; the cities of New York and Boston afford it about an equal and a very respectable and an increasing patronage. It is well



sustained by Connecticut and most of the Eastern States; it is not without patronage beyond the Alleghenies, but the state of the currency has made it necessary to relinquish an extensive subscription in those regions. Washington, Baltimore, Charleston, and the Southern States generally, but especially South Carolina, demand a very considerable number of copies, and all the smaller cities receive a proportionate supply."

Already, then, the journal had assumed the representative character which it still holds, and the position of its editor among the leaders of American science was assured.

Besides his class-room and his journal, Silliman's public lectures on scientific subjects, delivered in many parts of the country, were of great value in arousing popular interest. These, like his class-room lectures, were eminently pleasing in manner and brilliantly illustrated. The courses delivered in Boston in 1840-43 first inspired the boy Josiah Cooke with an interest in chemistry which bore fruit years afterward in the sudden establishment of systematic teaching of that subject at Harvard. In his own college, of course, his influence was direct and powerful, and it was mainly his support and approval which made possible the movement toward practical chemistry at Yale. So preparations were made for the great movement of fifty years ago. At Yale the son of Professor Silliman was one of the chief actors.

Benjamin Silliman, the younger of the name, was graduated from Yale in 1837. The sailing of the Wilkes exploring expedition, carrying away James D. Dana as geologist, left vacant at once for him a place as his father's assistant, and in his father's laboratory he received the chemical training not yet available in the undergraduate courses. Impressed with the value of this practical experience, he began in 1842 to receive a few students into his laboratory, among them

J. P. Norton, afterward his assistant and colleague. This personal and private instruction was the beginning of advanced chemistry at Yale. The 'Department of Philosophy and the Arts,' under the charge of the younger Silliman as professor of chemistry applied to the arts, and Mr. J. P. Norton, fresh from two years of study at Edinburgh and Utrecht, as professor of agricultural chemistry, took possession, in 1847, of the old President's House on the College green. They paid rental to the College for use of the building, and—such was the encouragement given in those days to the teaching of science—fitted it up at their own expense and served in it without salary. "The College, indeed," says Professor Lounsbury in his 'Historical Sketch of the Sheffield Scientific School, "the College, indeed, had no money to give, but, even if it had, it is more than doubtful whether it would have given it. No one at that time, however enthusiastic, ever dreamed of the supreme importance which the natural sciences soon were to assume in every well-devised system of education. The impression, indeed, seemed to prevail that chemistry, like virtue, must be its own reward."

The School, from an educational standpoint, was successful from the beginning. Norton's lamented death, in 1852, opened a place for J. A. Porter, a pupil of Liebig, who had just resigned a similar position in Brown University. Professor Porter was a son-in-law of Joseph E. Sheffield, and to this connection was due in a great measure the expansion of these beginnings into the Sheffield Scientific School.

At Harvard, at about the same time, two streams of influence converged to swell the interest in science teaching. E. N. Horsford was called to fill the 'Rumford Professorship of the Application of Science to the Useful Arts,' in Harvard University. Horsford was a graduate of the Rensselaer Polytechnic Institute, the earliest school in

the country to make a point of laboratory teaching. After seven years spent in teaching, surveying and geological work, under James Hall, he went abroad to study, becoming a favorite pupil of Liebig, and brought to Cambridge the methods and ideas of the Giessen laboratory.

He immediately formulated a scheme for the teaching of practical chemistry, and presented plans for a laboratory. These papers were laid by the Treasurer of the College before Abbott Lawrence, who supplied the necessary funds for this enterprise and for two other departments of geology and engineering. Agassiz was called to the chair in geology. The chemical laboratory was built in 1849, and Professor Horsford administered its affairs for sixteen years with vigor and success.

The tragedy connected with the name of Professor Webster left a vacancy in chemistry at Harvard, and in 1850 J. P. Cooke, then only twenty-three years of age, was elected to the Erving professorship of chemistry and mineralogy. The strongest opposing candidate for this position was David A. Wells, the first graduate in chemistry from the Lawrence Scientific School, since distinguished for his writings on economic subjects.

Cooke was in chemistry self-taught, with little experience as a teacher, but full of an inextinguishable enthusiasm, and an immense capacity for work. He was attracted at once to Liebig's methods, introduced by Horsford three years before. With the usual encouragement then given by college authorities in these subjects, he was permitted for the most part to provide his own apparatus and pay his own expenses, and not for seven years was his laboratory course admitted into the regular college curriculum. Even after this formal recognition a large part of the expenses of the chemical department was defrayed by Professor Cooke, and his private collection

of scientific apparatus became famous and of great service to others besides himself. As lately as August, 1871, Professor Trowbridge, in describing his new cosine galvanometer, says: "My thanks are due to Professor Cooke, of Harvard College, for the generous use of his apparatus for electrical measurements;" showing that even at that date the physical department of the College possessed no adequate collection of such instruments, but that the professors were still compelled to depend largely upon private resources.

A similar development began in 1850 at the University of Pennsylvania under James C. Booth, afterward developing into the Towne Scientific School, and at a little later date at the University of Virginia under J. Lawrence Smith. At Dartmouth College the Chandler Scientific school was founded in 1851.

At Brown University a heroic effort was made by President Wayland to enlarge the curriculum, introducing elective studies and increasing the possibility of scientific training. His notable report to the trustees, in 1850, was in advance of the age, and although an effort was made to carry out his suggestions, and chairs were established in practical chemistry and engineering, the movement gradually waned from lack of interest and support. A scientific school was established at the University of Michigan in 1852, and a chemical laboratory built in 1856. Few other colleges appear to have felt the rising scientific wave until later.

All these scientific departments centered at first around the chemical laboratory. This is only natural, as in that science the laboratory method of teaching was first systematically developed.

The great center of practical teaching, which revolutionized the methods of the world, was Liebig's laboratory, founded at Giessen soon after his establishment there as professor, in 1826. The direct influence

of this famous school upon Porter and Horsford has been already noted; the indirect influence, in all directions, must have been far greater.

Physical laboratories were yet unknown for some years, probably because the separation between chemistry and physics had not yet definitely taken place. The treatment of heat and electricity in the older text-books of chemistry, as agents of chemical change, tended to hold the two departments together, and in some large institutions, as, for example, the University of Michigan, these important portions of physics were, for nearly forty years after the period we are discussing, under the control of the department of chemistry.

As laboratory teaching in chemistry is connected with Liebig, so systematic laboratory work in physics is associated with the name of Kohlrausch, whose *Leitfaden*, still a standard work of reference, was the first practical text-book on that subject.

Professor W. B. Rogers appears to have made the suggestion which led to the establishment of the earliest physical laboratory in this country at the Massachusetts Institute of Technology, and Professor Pickering's Physical Manipulation opened the way for the ever-increasing host of laboratory manuals in physics.

It will be seen from the above sketch that the great incentive to the founding of scientific schools in this country was the growing appreciation of the value of applied chemistry in arts and manufactures.

Of general interest in pure science, at least chemical and physical, there was little or none; but the recognition of the value of applied science led, within a few years, to the great company of technical and engineering schools which have been, until very lately, the most imposing feature in our American system of higher education.

First among these, by many years, was the Rensselaer Polytechnic Institute, of

Troy, New York, the early history of which merits some attention. It was founded in 1824, by Stephen Van Rensselaer, and practically placed under the charge of his protégé, Amos Eaton. The purpose of the school was defined by the founder to be the instruction of 'persons who may choose to apply themselves in the applications of science to the common purposes of life.' "My principal object," he adds, "is to qualify teachers for instructing the sons and daughters of farmers and mechanics, by lectures or otherwise, in the applications of experimental chemistry, philosophy and natural history to agriculture, domestic economy, the arts and manufactures."

Professor Eaton gave to this philanthropic idea a turn of great originality and value. Since he was to educate chiefly lecturers, they should learn to lecture at the school. Since they were to lecture on the applications of science, they should themselves become practical manipulators. The work, therefore, of the classes consisted largely "of experiments in chemistry, performed by themselves, and in giving explanations, or the rationale of the experiments \* \* \*; the students thus themselves acting as lecturers, and the professors as students." Laboratory methods, in fact, were used throughout, and the school was equipped, so far as possible, with this idea in view. Doubtless the work was not so well systematized as in Liebig's laboratory, opened several years later, but it was an original and independent movement in the same direction, and that it was efficient may be inferred from the number of well-known men of science who were graduates of this school. Slowly, in response to popular demand, the Rensselaer Institute turned more and more toward engineering, and it is a curious fact that the very epoch which beheld other institutions broadening their scientific courses saw this one, in the reorganization of 1849-50, contracting its field

practically to that of a school for civil engineers.

Of the great number of technical schools which have sprung up since 1850 there is no need to speak. But the interest in science has gradually passed far beyond the mere interest in its applications.

The striking features of the last twenty years have been the spread of science teaching by laboratory methods in the secondary schools, and the growth of university instruction in science, as distinguished from technical. The noble gift of Johns Hopkins, and its wise administration, began the latter movement, which resulted in the establishment of graduate schools all over the country. The State universities, with their large resources, were, in some parts of the land, great aids in this work, though in others they kept more closely in touch with the technical side, as is very natural with institutions supported by the public at large.

The growing fashion among students, of completing their years of study in Germany, has had a most important effect. The instructors in science in our colleges are drawn more and more from those who have added German training to that of their native country, and as a result the ideals in these institutions are approximating to the German ideals.

Ability in the direction of original research is in some places the first quality looked for in a student or required of an instructor, and the modern tendencies toward extreme specialization and hasty publication are natural results.

So far the movement has undoubtedly been productive of good to the whole educational system of this country. There has been an arousing, an awakening, in educational ideas and methods, not in science only, but in all other subjects, that is little less than marvellous to him who can look back five and twenty years. Whether,

after our American fashion, the pendulum may swing too far, and the movement bring with it the difficulties which always attend exaggerations, it is too early yet to say, but, so far as we have gone at present, not only teachers of science, but all teachers, may join, in spirit at least, with the meeting at Boston, which really celebrates the beginnings, not merely of a scientific association, but of a great scientific and educational movement, of which the Association forms but a part.

FRANK P. WHITMAN.

---

HYDRAULIC ILLUSTRATION OF THE  
WHEATESTONE BRIDGE.

ALTHOUGH it is undesirable to push the analogy between the electric current and the flow of water too far, or to get the idea of an actual current too firmly established in the student's mind, still a hydraulic illustration is often useful to point out how the results may follow.

To show the action of the Wheatstone bridge by flowing water is usually complicated by the effects of gravity, and illustrates the conditions of pressure rather than those of resistance to flow. Moreover, the question of the galvanometer is a troublesome one, inasmuch as most devices require such a flow of water as to interfere with the bridge effects which it is desired to bring out.

The arrangement described below has proved quite satisfactory in showing the simpler resistance effects in the bridge, but especially useful in making clear the effects of capacity and self-induction, and how the two may be balanced and compared.

The accompanying sketch is taken from a simple home-made bridge which was constructed as an experiment. Upon a board about  $30 \times 50 \times 4$  cm. are fastened four glass *T*'s of about 5 mm. inside diameter. Two of these *T*'s have their side projections



turned inward and are connected, by short pieces of rubber tubing, to the 'galvanometer' *G*. The other two *T*'s have their side projections turned outward, and these connect by long pieces of tubing with two large aspirator bottles, not shown; *a*, *b*, *R* and *x* are brass strips held under a screw at the inside end and resting over rubber tubes which can be compressed and closed by the screws *s*s*s*s. These screws are made by soldering a piece of brass about 15 × 25 × 1 mm., with corners rounded, into the slot of a common wood screw. Under *R* is a piece of tubing several

pendicular so that it becomes a manometer. To start the apparatus fill the large bottle connected with *B* and set it higher than the board, tilt the *A* end of the board up ten or fifteen degrees, place the *A* bottle lower than the *B* one and open the stop cock (key) *K*. The water will flow through the tubes, driving out the air, and a little manipulation of *D* will bring the water in the manometer to a convenient point. The board is then to be placed horizontal again. By compressing *a* and *b* about equally resistance to flow is introduced into these two arms of the bridge; then compressing *x* will require a corresponding compression of *R* in order to balance the pressure in *G*. It will be readily seen that the qualitative effects can be thus shown, but for quantitative relations it would be necessary to replace the crude compressors by graduated stop cocks. The capacity can be regulated by closing *K*, raising the *A* bottle and taking the cork out of *C*, allowing it to fill more or less and then replacing the cork; the 'capacity' is proportional to the air left in *C*. When *C* is full there is no capacity in *x*. Self-induction is proportional to the length and curvature of the long tube, *H*, under *R*. Self-induction and capacity are shown by a momentary difference in level in the manometer upon opening and closing *K*, the throw (ballistic galvanometer) being in the opposite direction on closing *K* to that upon opening *K*. Changing the levels of the *A* and *B* bottles will show that the results are independent of the direction or value of the pressure (electro-motive force). The manometer (galvanometer) may be made more and more delicate by turning it down more and more nearly horizontal, and by projecting the image of *G* upon a screen its operation may be shown to a large class.

feet long when self-induction is to be shown; otherwise a short piece is used, like those under *a*, *b* and *x*, just long, enough to connect the corresponding *T*'s. *C* is a pint aspirator bottle, with its small side tubulure inserted into the side of the rubber tube. The 'galvanometer' is a *T* of peculiar form, as shown, closed at its top by a rubber tube and plug or pinch cock, as shown at *D*. It is really an electrometer, as it shows difference of pressure (potential) instead of current. In operation the board lies horizontal on a table and the tube *G* is stood up per-

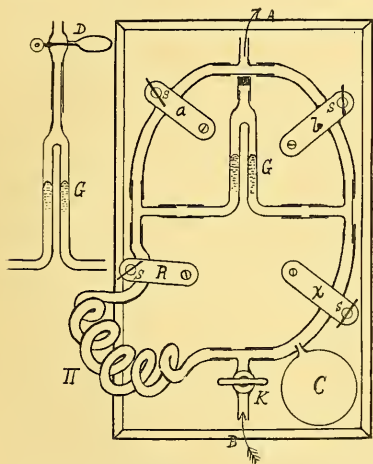

Individual ingenuity will devise many variations and improvements in details and experiments; the fancied merits of the ap-

paratus lie in the galvanometer device and in the elimination of the effects of gravity pressure in the bridge itself, as well perhaps as in the self-induction and capacity elements.

WILLIAM HALLOCK.

FAYERWEATHER HALL,  
COLUMBIA UNIVERSITY,  
July, 1898.

*THE ECHELON SPECTROSCOPE.*

THE invention of the Echelon spectro-scope is the most important advance in optical research which has been made in many years. It has always been the ambition of the physicist to spread the spectrum with which he was working out to the greatest possible length to see if perchance the changes in color are continuous or not. Thus it happened that a single prism gave way to trains of prisms, each member of the train doing its share to wrest asunder the inconceivably minute vibrations which were the objects of study. With this same end in view prisms gave way to diffraction gratings, these latter giving purer and more diffused spectra. Great labor and skill have been expended in improving these gratings until now their perfection has been pushed to well-nigh the limit of human possibility by the masterful work of Professor H. A. Rowland.

It, therefore, becomes evident that if this resolution of the spectrum is to be carried notably further some entirely new means of attaining the end sought must be adopted.

The important discovery by Zeeman last year that the magnetic field alters the nature of the vibrations of light roused physicists generally to a new effort to render visible these changes which are very small, their details lying beyond the reach of the best of Professor Rowland's gratings.

The result of these efforts is the Echelon spectro-scope, an instrument beautiful in its

simplicity, yet powerful beyond anything ever seen before. To its inventor, Professor A. A. Michelson, belongs the credit of opening the door to a new and hitherto unattainable field of spectroscopic observation, a field which promises to yield much valuable information to mankind regarding the interaction between the infinitely small particles of matter and those unseen forces, electricity and magnetism.

What, then, is the principle of this new instrument? The theory of diffraction gratings tells us that their dispersive power depends on two things: First, on the distance between two consecutive openings; and, second, on the order of the spectrum. The dispersion is greater the smaller the distance between the openings and the higher the order of the spectrum. The efforts of physicists have hitherto been directed towards making the distance between the openings of a grating as small as possible as a means of spreading the spectrum out as far as possible. No attempt has, so far as I know, been made before this to produce spectra of higher order than the fourth.

This is the point of the new instrument. It is capable of giving spectra of almost any order, the limit depending on the accuracy with which the plates composing it can be prepared. In the actual trial instrument made in this laboratory the order of the spectrum given is in the neighborhood of 20,000.

For the mathematical theory of the instrument the reader is referred to Professor Michelson's two articles on the subject.\*

One can gain a practical idea of its way of working as follows: A diffraction grating consists essentially, as is well known, of a series of equidistant openings. The spectrum of the first order is formed when the light in going from its source to the

\* *American Journal of Science*, March, 1898; *Astro-physical Journal*, June, 1898.

point of observation through one opening in the grating has travelled exactly one wave more than it has in passing from source to point of observation through the next adjacent opening. The spectrum of the second order is that spectrum which is formed when this difference of path amounts to exactly two waves, etc. Thus when one is observing the spectrum of the second order, say, he has matters so arranged that the light from the source is divided into numerous thin beams, each of these beams having to travel two waves farther to reach

polishing a plate of optical glass until its opposite surfaces are plane and parallel to each other, and then sawing this plate into pieces of the requisite size.

Suppose now a beam of parallel light to fall on this pile of plates perpendicular to the face at *A*. In passing through the first block from *a* to *b* the beam will be retarded by, say, 20,000 waves, the number depending on the thickness and the index of refraction of the glass. Part of the light then comes out into air through the narrow opening *bc* and the rest goes on through the

Fig. 1

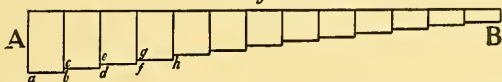

its goal than its adjacent beam on one side of it, and two waves less than its adjacent beam on the other side of it. If, then, one wishes to obtain spectra of the order 20,000, say, he must arrange the conditions of the experiment so that this difference in the optical path for various sections of the light shall be 20,000 waves instead of two. This result is accomplished in the Echelon spectroscope by building up a flight of steps of optical glass of a given thickness. The diagram (Fig. 1) shows a plan of this arrangement.

block *ed*. The part of the incident beam which comes out through the opening *de* has also been retarded 20,000 waves over the part that came through *bc* and so on. It is thus easily seen that this instrument, when looked through along the axis from *B* to *A*, gives the required conditions for the production of a diffraction spectrum of high order; for we have the light between the source and the point of observation divided into a number of beams, each of these beams having to travel 20,000 waves farther to reach its goal than its adjacent beam on

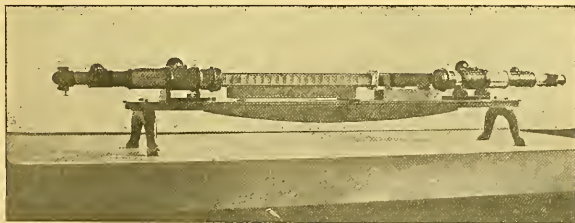

FIG. 2.

The blocks of glass composing this 'staircase' must be of exactly the same thickness, a result which is accomplished by

one side of it, and 20,000 waves less than its adjacent beam on the other side of it.

The cut (Fig. 2) represents a spectro-

scope built on this plan now in use in this laboratory. Its 'Echelon' consists of twenty plates each 18 mm. thick. Each plate projects 1 mm. beyond the next succeeding plate. It has a resolving power of about 300,000. A larger Echelon with thicker plates is being built here now which will have a still larger resolving power.

It is hard to say when the practical limit of resolving power by this instrument will be reached. But it is quite certain that 500,000 is soon to be attained. When we consider that the best gratings have a resolving power of only 100,000 we see how great an advance has already been made. Zeeman discovered that in the magnetic field the spectral lines were separated into three components, but with the Echelon spectroscope now in use here it is possible to see the doubling and tripling of these components which was discovered by Professor Michelson\* by means of visibility curves.

The disadvantage of the instrument is that it will not give a continuous spectrum, but its advantages in cheapness and enormous dispersion for small portions of the spectrum make it an invaluable addition to the means at hand for analyzing vibrations of light.

C. RIBORG MANN.

RYERSON LABORATORY,  
UNIVERSITY OF CHICAGO.

THE RELATION OF SCIENCE EDUCATION IN  
THE SECONDARY SCHOOLS TO THAT  
IN THE COLLEGE AND THE  
UNIVERSITY.†

In discussing the nature and the scope of the science work in the secondary schools one principle, I think, is recognized by all as being fundamental, and this is that the training of specialists is not the function

\* *Philosophical Magazine*, April, 1898.

† Address of the President of the Natural Science Department of the National Educational Association, July, 1898.

of the high school. Neither is it a part of the college in any but a limited sense, while, on the other hand, it most emphatically does come within the sphere of the university.

In laying down this principle, I am well aware that by far the greater number of high school pupils never intend to continue their education in any other institution of learning, and that their future advance must be made without the aid of professional teachers. To my mind, this makes no difference. There are certain broad foundations which, if the course is to be of lasting benefit, must be laid alike for all.

The development of the pupil's reasoning power and his faculties of observation are the important objects to be attained, and not to fill his mind with masses of facts and figures, which are as surely forgotten as they are learned. Such accumulations are defended only on the ground that they are of so-called 'practical benefit;' in reality, they constitute the most unpractical portion of any school course. Such things belong to the training of specialists, and consequently to the university, and even though the specialist can obtain a great number of necessary data from books and tables, after he has completed his studies he never can acquire the necessary fundamental training in the use of reason and logic, if he has neglected these essentials in the beginning. That which I have said applies to all branches of study—to the languages, to history or to mathematics as well as to the natural sciences; for all of them the same broad pedagogical principles are necessary.

I have used the term 'specialist' in its broadest sense in referring to high school students. It is in my opinion as grave a mistake to develop the pupil's training mainly along the scientific line as it is to confine him to humanistic studies alone. It is just as essential that the student in biology, physics or chemistry should be



well grounded in the languages, history and mathematics as it is for the other class to have a knowledge of the methods of scientific thought. In other words, I would have every high school pupil take work of both kinds, and I greatly deprecate the tendency to divide the secondary school curriculum into 'classical,' 'scientific' and 'English' from so-called 'practical' motives, for, as I have already said, these motives seem to me in reality the most unpractical. Some differentiation, no doubt, may be allowed, but none should be tolerated that will in any way be detrimental to a well balanced growth of the pupil's mind. The high schools will do good only in so far as they develop reasoning, thinking and normal citizens.

Coming to that topic which more nearly concerns us, the teaching of the sciences, it goes without saying that a smattering of a number of sciences is of no value whatever. No high school pupil can hope to become a scientist in the limited time during which he studies, nor even if time allowed is his mind sufficiently matured to enable him to have the proper point of view. As a consequence, it is of very little importance, with certain reservations, what sciences he studies, so long as he learns something of the methods of reasoning and the habits of thought which apply alike to all. Of course, it must always be borne in mind that certain sciences are fundamental to others, a considerable mathematical knowledge being necessary for physics, and undoubtedly a certain familiarity with physics is requisite before beginning the study of chemistry. Such subjects cannot be placed out of their regular order without doing violence to all; they must be kept so if the object aimed at, familiarity with the methods of scientific reasoning, is to be attained.

No one can hope to become conversant with all of the fundamental principles in

any one science in any one year, or even in many years, and that this is so is evident when we pause to consider the number of lives which during the last two or three centuries have been devoted exclusively to the task of bringing our methods in the sciences up to their present standpoint. Take the atomic theory alone. How many years of toil, how many hard-fought battles, how many great names, have during the past century been devoted to its perfection! Dalton, Berzelius, Guy-Lussac, Wöhler, Dumas, Stas, Avogadro, Cannizzaro, Clausius, Clerk-Maxwell, Thomson, Mendeléef and hosts of others have given their best years to it—and what it has taken such minds to develop we expect the high school student to grasp in a day! The same with all of the great theories of modern science; all represent the present convergence of many and often diverse views, held by numerous men who honestly fought and toiled in their chosen fields and whose names will live for all time. Shall subjects which represent so large a share of human thought be treated lightly as mere collections of shibboleths and signs, as mere accumulations of data, just as we remember how many pounds there are in a ton, or how many inches in a foot? Shall we value them simply for the applications which they may have in the obtaining of food and drink, and in the manufacture of clothing and machinery? Indeed, can we make any so-called 'practical applications' of them without comprehending the main theories on which they are based, and of which the application is only an offshoot?

All valuable theories in science must be, and are, founded on facts and facts only; their adoption has often been the result of the accumulation of a multitude of these, but their comprehension may be brought about by a careful selection of any one series, the members of which are so logically connected in the pupil's mind that the

theory must follow as a result of their existence.

The high school, then, should teach the student to reason in any science it undertakes to teach; it should give time enough to it so as to accomplish this end; it should carefully and conscientiously select those facts only which are of fundamental importance in developing the great theories, and it should so connect these facts that the great theories follow as a logical result. By so doing it will develop a thinking human being who can use what he has learned in any emergency, and who has in him the seed of further development. All other methods are false to science, misleading to the pupil, acting as soporifics instead of stimulants. On this line there can be no compromise.

All scientific work should be experimental. We have advanced to the point where this is universally recognized. It is, however, too frequently the custom to introduce experiments solely because they are cheap. This is a grave mistake. The main question should be: Do they teach what is necessary and are they not too complex for beginners? It is folly to attempt the study of a science with a lot of cheap and misleading experimental clap-trap. If fundamental experiments can be performed cheaply, so much the better, but if the science is to be properly taught they must be undertaken whether cheap or dear, or if financial considerations render this impossible the science itself should be abandoned in favor of something else. It is the same principle on which some people go shopping—they buy many things that they do not want, simply because they are cheap, and they go without the necessities because they are dear; yet if they would only refrain from the first line of action they might ultimately save enough for the second.

The high school course is preparatory to that of the college, but it can never take

the place of the latter. No student, however well prepared, can, in broadening his learning, afford to do without the fundamental work given by men who have, by their own researches, advanced their sciences. Only such men can truly generalize; only such men are able so to paint the scientific picture that the great truths stand out prominently against a background of minor facts and theories; only such men can produce an harmonious whole. It is in the very nature of things that the place of these advanced workers cannot be taken by the high school teachers. They have neither the time nor the opportunity, excepting in rare instances, to take any prominent part in the progress of their especial lines of work. For this reason the secondary school teacher should draw his inspiration from the investigators; he should follow them as leaders, and, in looking for such guidance, should first ask: 'What have they done?' not: 'With what institution are they connected?' It is a fallacy too often heard that the secondary school teacher alone can write for the secondary schools, because 'he understands the needs of the pupils.' True, he may understand how to write a book which will teach easily, but does he understand what are the fundamental principles of his subject? Does he not perhaps delineate what he *thinks* are the fundamental principles, without knowing that they may be either past history, or, worse still, entirely fallacious?

Too often the college teacher is compelled to entirely undo that which the pupil has learned in the high school—to clear the latter's mind of mistaken notions and to completely reconstruct his mental perspective—before the new work can be undertaken with mutual profit. Those who have gone through this trying ordeal realize that it is a far greater task to eliminate false impressions than it is to create new and right ones.

The high school teacher should develop the power of reasoning and exact observation; the college teacher the power of generalizing and the creative faculty; he should strive to teach the student to think in the terms of his science. To do this he must himself be a creator; he himself must have engaged in lines of original thought and investigation; he must be a living spring, not a pail of water. I have heard it said that the best teachers are often those who have never been able to engage in original research. I am inclined to doubt this. Granted, the investigator may not have the power of fluent speech in the same degree as some others, but he has the inspiration; he has the 'point of view;' he is able to feel relationships and connections which the other cannot, and as a consequence is able to place his pupil's learning on a broader and more permanent basis.

Finally, the college is not the place for narrow specialization; in it the scientific student should still be laying his broad foundation, with the understanding that he must also be gaining a clearer view of the sister sciences which are related to and necessary for an understanding of that which he has chosen for his main subject. The college is no more than the high school the place for technical training, for the latter is never developed in its proper form unless its foundations are laid broad and deep, so that they will, without strain, support any superstructure which may be placed upon them. It is only when this is the case that the university development can have its proper meaning. The college should bring forth the man *prepared* to specialize, not the man who has, by a too early following of a narrow line, stunted his power of future development. The university should be able to take many things for granted; it should at once be able to devote its time to the growth of the professional biologist, physicist, chemist, mineral-

ogist or geologist; and, while, of course, it cannot lose sight of the fact that at no stage of the scientific career are the related sciences to be neglected, it should, nevertheless, be able to count on training proper and sufficient to fit the student for the original thought and work which must become a part of his being; for, if he wishes to accomplish anything, these habits must be with him through life.

In this way the scientific training of a student becomes a harmonious whole without break, let or hindrance, from the beginning in the secondary school up to the mature work of the investigator and teacher; for the members are of one race and of one people, forever whole and indivisible.

PAUL C. FREER.

THE UNIVERSITY OF MICHIGAN,  
ANN ARBOR.

---

THE LACOE COLLECTION IN THE NATIONAL  
MUSEUM.

IN SCIENCE for July 3, 1896, the late Dr. G. Brown Goode announced the very valuable gift of the 'Lacoe Collection of Fossil Plants.' At that time Mr. R. D. Lacoe, a leading business man of Pittston, Pennsylvania, presented to the U. S. National Museum by far the largest and most valuable collection of Paleozoic plants in America, comparing favorably with the richest collections of the same nature in European museums. Living in a region rich in fossil plants, and noting early in the seventies that no great collections of this kind were accumulating, and also that little or no attention was being given to securing American Paleozoic insects, which are among the rarest of fossils, he quietly set to work gathering material and assisting paleontologists in the study of his collections. The plant collection contains nearly 100,000 specimens and is stored in 1,000 museum drawers and many large exhibition cases. There

are about 750 types and illustrated specimens in the collection.

Recently Mr. Lacoe has presented the balance of his splendid collections, consisting chiefly of fossil insects. The liberality of the gift is as unfettered with conditions as its value is great. The collection is to be known as the 'Lacoe Collection,' and the only stipulation is "that it be accessible to scientists and students without distinction, provision being made for the proper preservation of the specimens from loss or injury."

Of the 182 described species of North American Paleozoic insects about two-thirds are represented in the 'Lacoe Collection' by the type specimens, besides many figured supplementary types. Of arachnids there are 62 specimens (14 types), myriapods 94 specimens (41 types), and insects 461 specimens, of which 116 species are described (136 types); about 300 specimens are unstudied. There is but one other Paleozoic collection equalling or exceeding in specimens the Lacoe Collection, namely, that from the coal fields of Commeny, France.

Of Tertiary insects from Florissant, Colorado, several hundred unstudied specimens and six described species are present, including a butterfly, one of the rarest of fossil insects. From the Tertiary of Oeningen, in Baden, there are about 3,500 specimens, of which about one-half (including about 428 species) have been studied by Mr. Samuel H. Scudder. Regarding this part of the Lacoe Collection Mr. Scudder writes (Geol. Mag. Dec. IV., Vol. II., 1895, pp. 116-122): "I have examined with some care his large collection of fossil insects from Oeningen, larger, perhaps, than any outside of Zurich, for it consists of about 3,500 specimens, of which fully one-half may be made use of to advantage.

"The 428 species which I have separated in Mr. Lacoe's collection are divided among

the orders as follows: Orthoptera 8, Neuroptera 13, Hemiptera 57, Coleoptera 294, Diptera 17, Hymenoptera 39." From the Mesozoic and Cenozoic of Great Britain there are about 250 specimens.

Of Crustacea there are about 170 specimens, of which 11 are types or figured specimens. Of fishes and reptiles there are some 300 specimens, about half of which were labeled or described by the late Professor Cope.

Mr. Lacoe intends to continue his interest in the increase and study of 'The Lacoe Collection.' With the numerous Tertiary insects from the Western States gathered by the United States Geological Survey and studied or to be studied by Mr. Scudder, the United States National Museum will have one of the most comprehensive collections of fossil insects extant.

Dr. Goode's appreciative words regarding the plant collection are also applicable to the insect collection: "The acquisition of this wealth of material makes the National Museum an important reference center for all future comprehensive work in this field. The Lacoe Collection is a noble monument to the public spirit and generous enthusiasm of its founder."

#### A NEW NAME FOR THE GEORGIA OLD FIELD MOUSE.

In my 'Land Mammals of Peninsular Florida and the Coast Region of Georgia,' (Proc. Boston Soc. of Nat. Hist., Vol. 28, No. 7, pp. 202-203, March, 1898), I described under the name '*Peromyscus subgriseus arenarius*,' the dark-colored form of the old field mouse found by Mr. W. W. Brown, Jr., on the sand hills about Hurstman's Lake (Savannah River), near Bascom, Scriven Co., Georgia. After my manuscript had been turned in I noticed that I had used a name already given to a *Peromyscus* by Dr. E. A. Mearns. (The *Peromyscus eremicus eremicus* Mearns, Proc. U. S.



Nat. Mus. Washington, p. 138, 1896.) I meant to correct my mistake when I read my proof, but I neglected so to do.

It, therefore, becomes necessary to give the Georgia old field mouse a new name and I propose for it *Peromyscus subgriseus baliolus*\* nom. nov. Type, No. 5925, Coll. of E. A. and O. Bangs, described under above reference as *Peromyscus subgriseus arenarius*.

OUTRAM BANGS.

#### BOTANICAL NOTES.

##### SEEDS AND VERY LOW TEMPERATURES.

Two English investigators, H. T. Brown and F. Escombe, recently made some interesting experiments upon the ability of seeds to endure very low temperatures. In the Jodrell laboratory, of the Kew Gardens, they enclosed seeds in thin glass tubes immersed in a vacuum-jacketed flask containing about two liters of liquid air; the latter was replenished so as to submit the seeds, for one hundred and ten hours, to a temperature of from  $-183^{\circ}$  C. to  $-192^{\circ}$  C. ( $-297^{\circ}$  Fahr. to  $-313^{\circ}$  Fahr.). The seeds used were: *Hordeum distichon*, *Avena sativa*, *Cucurbita pepo*, *Cyclanthera explodens*, *Lotus tetragonolobus*, *Pisum elatius*, *Trigonella foenum-graecum*, *Impatiens balsamina*, *Helianthus annuus*, *Heraclium villosum*, *Convolvulus tricolor* and *Funkia sieboldiana*. They had previously been air-dried, and contained, when the experiment was begun, from ten to twelve per cent. of moisture. After their prolonged exposure to the intense cold indicated above, they were slowly thawed, the process requiring about fifty hours. They were then tested as to their germinative power, by comparison with seeds from the same lots, which had not been subjected to this low temperature, with the result that 'their germinative power showed no appreciable difference from that of the controls, and the resulting plants, which were in most cases grown to full ma-

turity, were equally healthy in both cases.'

This astonishing result can not fail to attract much attention, not only of botanists, but of gardeners and farmers as well. That this was not due to unusual or accidental conditions is shown by experiments by other investigators, cited by Messrs Brown and Escombe. Thus DeCandolle and Pictet in 1884 exposed seeds for four days to a temperature of  $-100^{\circ}$  C. ( $-148^{\circ}$  Fahr.) without destroying their vitality, and in 1895 the former exposed seeds in the 'snow box' of a refrigerating machine for a period of one hundred and eighteen days to a temperature of from  $-37^{\circ}$  C. to  $-53^{\circ}$  C. ( $-34.6^{\circ}$  Fahr. to  $-63.4^{\circ}$  Fahr.), a treatment which most of the seed are said to have 'resisted successfully.'

While these experiments are very interesting as showing that mere lowering of temperature may not necessarily destroy the vitality of seeds, it is fair to the investigators to say that this was not their principal object. They aimed to determine the condition of the protoplasts of the resting seed, whether (1) 'the essential elements of the cell, during the period of inertness, are still undergoing feeble but imperceptible alteration, accompanied by gaseous interchange with the surrounding atmosphere,' or (2) 'that all metabolism is completely arrested in protoplasm when in the dormant state, and that it then loses, for the time being, all power of internal adjustment to external conditions.'

In other words, they asked the question: 'Is the machinery of the dormant cell merely slowed down to an indefinite extent, or is it completely brought to rest for a time, to be once more set going when external conditions are favorable?' To this question they make answer that 'we must regard the protoplasm in resting seeds as existing in an absolutely inert state, devoid of any trace of metabolic activity, and yet conserving the potentiality of life.'

\* Baliolus=dark-brown, swarthy.

THE SCIENTIFIC WORK IN THE DEPARTMENT  
OF AGRICULTURE.

It is not many years since the scientific men of this country were entirely indifferent to the work of the United States Department of Agriculture. They were indifferent because the work of the Department was so poorly done that trained men knew that it was practically valueless; now and then one still finds a remnant of this old feeling in elderly men who have not kept in touch with the development of the Department during the past few years. That this prejudice has no longer any foundation in fact (if we except the free-seed-distribution folly) may be seen by an examination of the recently published 'Historical Sketch of the United States Department of Agriculture,' compiled by Charles H. Greathouse, of the Division of Publications. From it we learn that there are a full dozen 'divisions,' 'bureaus' and 'offices,' which are concerned with scientific problems. Botanists are interested especially in the Division of Botany, established in 1869; Division of Forestry, established in 1881; Division of Vegetable Physiology and Pathology, established in 1886; Office of Fiber Investigations, established in 1890; Division of Soils, established in 1894; and Division of Agrostology, established in 1895. For these divisions there are annually appropriated for expenses, from \$80,000 to \$100,000, in addition to separate appropriations for salaries, library and museum. If we add the Divisions of Chemistry, Entomology and Biological Survey, the aggregate of the appropriations reaches about \$150,000. Every one of these divisions is in charge of well trained scientific men, who have surrounded themselves with expert assistants selected with great care and with especial reference to their preparation for the work to which they are assigned. No mention need be made here of the Weather Bureau,

or of the Bureau of Animal Industry, with whose work the people at large are quite generally and favorably acquainted.

The publications from these scientific divisions reflect great credit upon the management of the Department. This is notably true of the divisions pertaining to botany, from which we have had many valuable scientific papers.

BOTANICAL PAPERS IN THE NEBRASKA ACADEMY OF SCIENCES.

THE botanical papers printed in the recently issued 'Publications of the Nebraska Academy of Sciences, VI.,' are as follows: 'The Nomenclature of the Nebraska Forest Trees,' by Charles E. Bessey (giving the now generally accepted names of the sixty-seven species of native trees, and discussing their synonymy); 'A Comparison of Fossil Diatoms from Nebraska with Similar Deposits at St. Joseph, Mo., and at Denver, Colo.,' by C. J. Elmore (showing that these must have grown in fresh-water ponds or lakes); 'An Observation on Annual Rings,' by F. W. Card (showing that, contrary to popular belief, the growth of a second ring of wood in tree trunks does not occur as a result of defoliation); 'On the Internal Temperature of Tree-Trunks,' by R. A. Emerson (giving the results of a prolonged study of the problem, and showing that the temperature is greatly affected by the amount of water present); 'Data as to Wind-Distribution of Seeds,' by Edward M. Hussong (giving the results of observations by means of collecting trips, showing that while 'high winds' are effective agents in the distribution of heavy and rounded seeds they are by no means efficient in the dispersion of the comose, pappose and membranaceous seeds, these being carried much more efficiently by the lighter 'breezes' and 'local winds'); 'Chalcedony-Lime Nuts from the Bad Lands,' by Erwin H. Barbour (describing and figuring fossil embryos of seeds ob-

tained from the Miocene formation of the Bad Lands of the Hat Creek Basin, in northwest Nebraska; for these the name *Archihicoria siouensis* is proposed, the embryo showing unmistakably their close relationship to the modern *Hicoria*.

#### THE OVARY OF OPUNTIA.

DR. JOSÉ RAMÍREZ, in the *Anales del Instituto Médico Nacional*, of Mexico, describes and figures three monstrous ovaries of *Opuntia*, which he regards as evidence of the axial nature of the inferior ovary in general. In the first case the ovary, though entirely normal in color, function, etc., instead of being articulated with the joint, is fused with it. Moreover, the spiral disposition of the arolae is continuous from joint to ovary. In the second example the ovary resembles a joint externally, while within it is in no wise different from a normal ovary. In the third a mature ovary bears thirteen perfectly developed ovaries, which are arranged spirally upon it. From the fact that the uppermost are already mature, the author concludes that the inflorescence of *Opuntia* is determinate.

CHARLES E. BESSEY.

THE UNIVERSITY OF NEBRASKA.

#### CURRENT NOTES ON ANTHROPOLOGY.

##### ON PYGMY RACES.

MR. R. G. HALIBURTON has devoted much time to the study of the pygmy races of men, and it is to his researches that the learned world owes the best information about the small people of the Atlas and Pyrenees Mountains.

Under the title 'How a Pygmy Race was found in North Africa and Spain' (Toronto, 1897, pages 147), he has republished the scattered articles containing his results, and added, also, various papers on other anthropological topics. Among the latter, as touching upon points of special interest,

I may note one on 'The Days of Rest of Prehistoric Men,' which refers to the inauspicious, intercalary days of primitive calendars; and one on 'The Connection of November Flood-Traditions with the Pleiades,' where he ingeniously suggests that the sacredness of the number four in many mythologies may be due to the fact that the heliacal rising of the Pleiades corresponds to that of the new moon once in four years. Five articles refer to the Gypsies in Africa, and several to the customs and myths of ancient Egypt.

#### UNSOLVED PROBLEMS OF ANTHROPOLOGY.

MR. E. W. BRABROOK, in his third inaugural address as President of the Anthropological Institute of Great Britain, reviewed the recent progress of the science of man, and recounted the unsolved problems which it offers. It is worth while to quote these, as to know where we are especially deficient is the best preparation for extension of knowledge.

He mentions: (1) the development from the brute to man; (2) the *hiatus* between the palaeolithic and neolithic periods in Europe; (3) the process of the disappearance of races; (4) the development of religions; (5) the accurate measurement of different races; (6) the record of the passing mental phases of humanity.

The postulates which he claims the science of anthropology should always regard as fixed beyond doubt are: (1) the unity of the anthropologic sciences (in aim, I suppose); and (2) the doctrine of the continuity of the phenomena which it studies. These suggestions from one who understands the field so thoroughly merit careful reflection.

#### ABOUT THE HITTITES.

THE latest contribution toward an identification of the Hittites with some known stock is from the pen of Professor Fritz Hommel, and is printed in the *Sitzungsberichte* of

the Bohemian Academy of Sciences, 1898, under the title 'Hethiter und Skythen.'

From a thorough study of sources he shows that the Scythians were an Aryan and especially an Iranian folk. It is clear that a portion of them lived in Cilicia and Cappadocia, where other authorities locate the Hittites; and in Mitanni certainly some Aryan blood must have entered, for the Amarna tablets speak of the Mitanni princess as 'blue-eyed.' Also the Amorites were blonde and blue-eyed. To these facts of a physical character Hommel adds a lengthy investigation into proper names, all tending to illustrate a deep Iranian influence in eastern Anatolia. This does not exclude, but much modifies, the 'Ajarodian' hypothesis of Sayce and others. Of course, that the Hittites were Aryan has already been asserted by other writers, but not in the form here presented.

D. G. BRINTON.

UNIVERSITY OF PENNSYLVANIA.

#### SCIENTIFIC NOTES AND NEWS.

THE death of Dr. James Hall, which occurred at Echo Hill, Bethlehem, N. H., on August 7th, at the age of eighty-seven years, will cause universal regret among men of science. Since Dr. Hall's return from the International Geological Congress, last year, his health has been failing somewhat, but he fully intended to attend the approaching fiftieth anniversary meeting of the American Association, of which he was one of the founders. It will be remembered that at the meeting of the Association at Buffalo, two years ago, a special session was devoted to appreciations of Dr. Hall's scientific and official work as Geologist of the State of New York for fifty years. Portraits of Dr. Hall were included in the full report that appeared in SCIENCE at the time.

PROFESSOR EDWIN RAY LANKESTER, Linacre professor of comparative anatomy at Oxford, has been appointed Director of the Natural History Museum, South Kensington, in succession to Sir William Henry Flower.

PROFESSOR MOSSO, of Turin, has been elected a correspondent of the Paris Academy of Sciences in the section of medicine and surgery. Twenty-six votes were cast for Professor Mosso and ten for Professor Zambaco, of Constantinople.

DR. CARL I. CORI, of the German University at Prague, has been elected Director of the Zoological Station at Trieste.

DR. F. J. V. SKIFF, Director of the Field Columbian Museum, Chicago, has been appointed Director of Mining and Mineralogy at the Paris Exposition of 1900.

LORD PEEL has been appointed a trustee of the British Museum in the place of the late Mr. Spencer Walpole.

It is proposed to erect a bust of Victor Meyer in the chemical laboratory at Heidelberg, and should sufficient money be collected a scholarship for the advancement of chemistry will be established.

THE monument to Charcot will be formally unveiled in the Salpêtrière in Paris on October 23d.

PROFESSOR PARK MORRILL, Chief of the Forecast Division of the Weather Bureau, died at Washington on August 8th of typhoid fever.

THE death is announced of Dr. E. B. Aveling, in London, on August 4th, at the age of 47 years. He had been assistant in physiology at Cambridge and professor of chemistry and physiology at New College, and had written on scientific topics, especially in the direction of the popularization of the doctrine of evolution. He was, however, best known as a lecturer and writer on socialism.

M. PAUL SEVRET, the mathematician, member of the Paris Academy of Sciences, died in Paris on June 24th, aged seventy years.

WE regret further to record the death of Professor W. F. R. Suringar, professor of botany in the University of Leyden and Director of the Botanical Garden and Herbarium.

A FOURTH International Congress of Agriculture will meet at Lausanne from the 12th to the 17th of September.

DR. HENRY BESSEMER has presented to the



British Astronomical Association the observatory erected by the late Sir Henry Bessemer.

MR. BALFOUR, leader of the British House of Commons, recently made an interesting address on the subject of research on the occasion of the distribution of prizes at the medical school of Guy's Hospital, which led a member of the audience to send an anonymous gift of \$6,000 for the endowment of medical research.

M. A. GAUDRY recently stated before the Paris Academy of Sciences that Victor Lemoine had bequeathed his valuable paleontological collection to the Paris Museum of Natural History. His widow has given to the Museum the land at Cernay, near Reims, whence the fossils had been obtained.

THE annual meeting of the Corporation and Board of Trustees of the Marine Biological Laboratory was held at Woods Holl, Mass., on August 9, 1898. The report of the Director showed the Laboratory to be in a flourishing condition and the attendance large. The following is a list of the Board of Trustees and the officers for the ensuing year: *President*, H. F. Osborn; *Director*, C. O. Whitman; *Assistant Director*, J. I. Peck; *Secretary*, H. C. Bumpus; *Treasurer*, D. Blakely Hoar. *Trustees*, to serve four years: E. G. Conklin, Camillus G. Kidder, M. M. Metcalf, William Patten, D. P. Penhallow, W. B. Scott. To serve three years: S. F. Clarke, E. G. Gardiner, J. P. McMurrich, L. L. Nunn, H. F. Osborn, E. B. Wilson. To serve two years: William Libbey, W. T. Sedgwick, W. K. Brooks, William Trelease, W. P. Wilson, R. Ramsay Wright. To serve one year: J. H. Macfarlane, F. P. Hall, Jacques Loeb, T. H. Morgan, W. A. Loey.

THE second report of the select committee of the British House of Commons appointed to inquire into the administration and cost of the museums of the Science and Art Department was finally adopted on July 29th by 7 to 3. Perhaps the most important recommendation is to the effect that with a view to the efficient and economical management of the museums in London, to say nothing of other educational advantages not within the order of reference, the committee deem it of paramount importance that there be an Education Minister of

Cabinet rank having a seat in the legislature aided by a Parliamentary Secretary. It is recommended that the Geological Museum in Jermyn-street be not occupied as now, but that the collections there exhibited be removed to the west side of Exhibition-road as a science collection.

THE Manitou and Pike's Peak Railroad has arranged to build an observatory on Pike's Peak, but it does not appear at present to be intended to be used for scientific purposes.

THE dedication of the new biological and dairy building at the New York Agricultural Experiment Station at Geneva will take place on or about September 14th.

THE British government has been asked by the Royal Scottish Aboricultural Society for a grant of \$200,000 for the establishment of a State Forest near Edinburgh, which it is intended to cultivate according to the methods of modern forestry as an example to landed proprietors. It would also be used for research in forestry.

PROFESSOR BEHRING has secured a patent on the manufacture of diphtheria antitoxin in the United States. This appears to be an unfortunate exception to the moral code which prevents medical men from making monopolies of the remedies they discover. Still it must be remembered that such a patent permits the preparation of the antitoxin under standard conditions and will not of necessity increase the price. The remarks of the medical journals seem rather extreme, as witness the following from the *Medical Record*: "Professor Behring \* \* \* now thinks he is in position, with loaded syringe, to demand of every defenceless babe its money or its life. We do not believe the courts will legalize any such impudent attempt at brigandage."

THE Congress of the Royal Institute of Public Health, under the presidency of Sir Charles Cameron, M.D., is now being held in Dublin. The *British Medical Journal* states that the local preparations are on an extensive scale. The local committee is large and representative, and the subscriptions so far received are generous enough to make it certain that the entertainments will be exceptionally good. The meet-

ings of the various sections take place in Trinity College; the Health Exhibition is held in the buildings of the Royal University, and a banquet in the Royal College of Surgeons. There are four sections—Preventive Medicine and Vital Statistics, Chemistry and Meteorology, Engineering and Building Construction, and Municipal and Parliamentary. In addition, there is a conference of army medical officers on Enteric Fever in the Army, and by medical officers of health on the Housing of the Poor and the Prevention of Tuberculosis. Among the general subjects discussed in the various sections are: The Treatment of Infectious Diseases in General Hospitals, the Increase of Lunacy in Ireland, the Management of the Sick in Workhouse Hospitals, Pollution of Rivers and Treatment of Sewage, and Designing and Construction of Hospitals.

It is announced that the steamship *Valdivia*, with the German deep-sea expedition will leave Hamburg immediately.

MR. W. C. ANDREWS, whose expedition to Christmas Island was reported sometime since, is now returning, having made a careful study of the geology of the island and exhaustive collections of its animals and plants.

FEARS are entertained in regard to the steamship *Belgica* which sailed for the Antarctic regions last year.

PROFESSOR SALISBURY, of the University of Chicago, has taken a party of ten students on a geological expedition to the Yellowstone Park.

THE London *Times* reports that the government of the Independent State has just sanctioned an important measure for the advancement of scientific knowledge on the Congo. The despatch last spring of the expedition under Lieutenant Lemaire was a commencement in this direction, but, whereas his explorations will be chiefly in the Tanganyika region, the new measure will apply to the whole of the State. Twenty posts which are to form the centers of observation, and also the bases for the collection of flora, fauna and mineralogical specimens, have been decided upon, and are now being carefully organized under the supervision of the proper officers at Brussels. As soon as the posts are in working order a pub-

lication will be issued at Brussels for the purpose of recording the results of these experiments. It will be issued every six weeks, under the title of 'Scientific Annals.'

MR. AKERS-DOUGLAS stated recently in the British House of Commons that the Director of Kew Gardens had informed him in April last that volume 4 of the *Flora of Tropical Africa* was in an advanced state of preparation, but very little of it appears to be yet in type. Two other volumes, Nos. 7 and 5, are being printed first. The third and last part of volume 7 is nearly ready. There have been certain difficulties as to the printing of volume 5, but the publishers have now declared themselves ready to proceed with it.

WE learn from *Literature* that Mr. G. Boulger, professor of botany and geology at the City of London College, in addition to his work for the 'Dictionary of National Biography,' in which the Tradescants have occupied him a good deal of late, has been engaged in seeing through the press a new and rewritten edition of the Rev. C. A. Johns' 'Flowers of the Field.' Professor Boulger is also at work upon a new book, a manual on 'Wood' for Mr. Edward Arnold's 'Practical Science Series,' and, in conjunction with Mr. James Britten, he is publishing in *The Journal of Botany*, for subsequent issue in separate form, a supplement to their 'Biographical Index of British and Irish Botanists.'

MESSRS. D. C. HEATH & Co. announce a book on 'American Indians' by Professor Frederick Starr, of the University of Chicago.

THE following regulations have been announced in regard to workers in the Lancashire Sea-Fisheries Hatchery and Laboratory at Piel, Barrow-in-Furness, Lancashire: (1) Biologists and students desiring to work at the Piel Hatchery should apply to the honorary Director (Professor Herdman), who, if there is room, will allot them work places in the Laboratory in the order of application. (2) In the absence of the Director, the Resident Assistant (Mr. Andrew Scott), will determine which places in the Laboratory workers are to occupy, and to what extent the instruments in the Laboratory (microscopes, microtomes, etc.) and the boats and collecting apparatus may be used by workers.

(3) The aquaria in the tank house are intended for experiments in fish hatching and fish rearing, and it is only by express permission of the Director or the Resident Assistant that they may be used for private investigations. (4) Laboratory accommodation and lodging in the house are given free of charge to those duly qualified workers or students whose applications have been accepted, and who have been assigned a place in the Laboratory. Meals are provided for those working in the Hatchery at a fixed charge. (5) The Resident Assistant will be ready to give assistance to workers at the Hatchery, and to provide them with material for their investigations so far as it does not interfere with his routine duties and his 'fisheries' work. (6) All dishes, jars, bottles, tubes and other vessels in the Laboratory may be used freely, but must not be taken away from the Laboratory. If any workers desire to make, preserve and take away collections of marine animals and plants they must provide their own bottles and preservatives for the purpose. (7) The fish and other specimens in the tank room are the property of the institution and must not be used or disturbed by workers in the Laboratory. (8) Each worker in the Laboratory is required to send a short account of his work done at the institution, and of the results he has attained, to the Director before the 1st of December (at latest), in order that it may be entered in the Annual Report to the Sea-Fisheries Committee.

At the summer meeting of the British Institution of Mechanical Engineers, which commenced at Derby on July 26th, Mr. E. Ristori read a paper on aluminium manufacture, with a description of the rolling mills at Milton, Staffordshire. According to the report in the *London Times*, the writer of the paper stated that at the Belfast meeting in 1896 a paper was read which fully described the method adopted for the preparation of pure alumina (oxide of aluminium) from bauxite. Since that time the British Aluminium Company had enlarged their works at Larnie, and great improvements had been introduced into the process of manufacture. The finished product was a very finely divided powder, and in order to ship it to Foyers it had been found advisable to pack the alumina in

hermetically-sealed steel drums. The oxide was reduced by the Héroult process and the metal run out of the electrolytic baths into ingot moulds. In this form the aluminium was quite pure enough for certain purposes, and much of it was therefore sold without further treatment; but it was not suitable for the production of tubes, rods, etc. The crude ingots were therefore sent to Milton, where they were refined until the metal attained a purity of 99.6 per cent. With certain limitations imposed by the chemical and physical peculiarities of the material, aluminium could be worked much like the other industrial metals handled at the present day. Aluminium could be forged hot or cold, and, in comparison with other metals, it ranked third in order for malleability and sixth for ductility. Sheets had been hammered as thin as one forty-thousandth of an inch. In turning the edge of the tool soon became blunt, and the cutting speed should be high. In its purest form aluminium was very soft, and not of great service in those arts in which much rigidity and strength were required. One casting alloy having a specific gravity of 2.9 was largely used just now, and its composition was still kept secret. It had been found to produce remarkably clean castings which required very little machining to finish up, and it took a high polish. Another alloy contained nothing but aluminium and a small proportion of copper, but it was not one of the materials generally recommended. The two alloys particularly recommended as among the best yet made were both ternary alloys, and next to the aluminium tungsten was the leading ingredient in each. In one of them copper was present to a small extent, and in the other nickel, and both had given astonishing results as regards strength and elongation. Samples of rolled sheets or rods made of these alloys had shown as much as 20 to 22 tons tensile strength per square inch, with 5 to 10 per cent. elongation in four inches. Aluminium bronzes were undoubtedly superior in strength and they were especially suitable for marine engineering. The writer gave a great many illustrations of the uses of aluminium, and, speaking broadly, he said that the metal or one of its light alloys should, to a large



extent, replace copper, tin and nickel. Its use in shipbuilding was growing rapidly.

THE report has been issued as a Parliamentary paper of a visit of inspection made to French matchworks at Aubervilliers, Pantin and Marseilles during June by Dr. Thomas Oliver, of Newcastle, one of the experts appointed by the Home Secretary to inquire into the matter of lead poisoning in the potteries and also into the dangers incidental to lucifer match making. The following are Dr. Oliver's general impressions and deductions: (1) Until recently the match-makers in certain of the French factories suffered severely from phosphorus poisoning; that at the present time there is apparently a reduction in the severer forms of the illness. (2) That the reduction in the amount of illness is attributable to greater care exercised in the selection of the workpeople; raising the age of their admission into the factory; medical examination on entrance; subsequent close supervision; repeated dental examination; personal cleanliness on the part of the workers; early suspension on the appearance of symptoms of ill-health; improved methods of manufacture. (3) That the French government, aware of the dangers of match-making, is furthering, by all possible means, new methods of manufacture, and, with this object in view, retains in its service chemists and inventors who are continually making experiments. (4) That the government has to some extent already succeeded in manufacturing a match capable of striking anywhere, yet free from white phosphorus, but that until now the manufacture of this match is not an industry.

THE London *Times* gave last year an account of some satisfactory tests carried out on wood which, by a process of American origin, had been rendered incombustible, or, at least, incapable of sustaining and conveying flame. It now states that the first works in Europe for the application of this process, erected by the British Non-Flammable Wood Company near the Middlesex end of Wandsworth-bridge, were recently opened, when a number of visitors witnessed another practical demonstration of the enormous power to resist fire possessed by 'non-flammable' wood in comparison with

ordinary timber. The process may be said, roughly, to consist of removing the natural juices of the wood and replacing them with certain substances which not only make it fire-proof, but also have antiseptic properties that prevent decay. The operation is effected in retorts or cylinders, the largest of which are 105 feet long by 7 feet in diameter. The wood having been run in on trolleys, the air-tight door is closed and the contents subjected to heat and the action of a high vacuum. This treatment is continued till the volatile and fermentable constituents have been withdrawn, the time required to attain this result varying with the character of the wood. The next step is to fill the cylinder with the fire-proofing solution, the exact composition of which is kept secret, and force it into the wood under hydraulic pressure, the amount of which again differs for different woods, but may reach 150 pounds to the square inch or more. When thoroughly impregnated with the salts the timber is taken out of the cylinders, restacked on the trolleys, and put into the drying-kiln—a room through which hot air is continually circulated by powerful fans, and which is fitted with apparatus to condense the vapors given off by the wood. Here it remains till it is thoroughly dried—in the case of a load of average thickness about a month. It is then ready for delivery and use. It may be mentioned that the British company claims, as the result of exhaustive experiment, to have improved materially on the original American process by getting rid of certain disadvantages connected with moisture and corrosion.

A SELECT committee of the House of Commons has been appointed to inquire into the working of the telephone service. It appears from testimony given before the committee that, while as a whole Great Britain is in advance of Germany in the use of the telephone, many German cities use the instrument more than cities of the same size in Great Britain. Thus Glasgow, with a population of 656,000, had 7,612 telephone instruments; Cologne, with a population of 292,887, had 4,113 instruments; Liverpool, with a population of 860,000, had 10,935 instruments; and Hamburg, with a population of 573,792, had 13,561 instruments.



to London and Berlin, the population of London within the municipal area was 4,200,000, and there were 25,724 instruments, while in Berlin, with a population of 1,578,794, there were 36,620 instruments.

#### UNIVERSITY AND EDUCATIONAL NEWS.

THE University of Chicago has established a College for Teachers, which has been endowed by Mrs. Emmons Blaine with \$250,000.

PROFESSOR W. LE CONTE STEVENS, of the Rensselaer Polytechnic Institute, has accepted the chair of physics in Washington and Lee University.

DR. CLEVELAND ABBE, JR., has resigned a fellowship in the Teachers College, Columbia University, to accept a chair in Western Maryland College, Westminster, Maryland. Dr. C. C. O'Hara has been elected professor of geology and mineralogy in the South Dakota School of Mines. Mr. Wm. H. Butts and Mr. A. W. Whitney have been appointed instructors in mathematics in the University of Michigan.

DR. ZOGRAF has been elected extraordinary professor of zoology, and Dr. Mrensblér, extraordinary professor of comparative anatomy in the University of Moscow.

#### DISCUSSION AND CORRESPONDENCE.

##### OBSERVATIONS ON BLUE JAYS.

TO THE EDITOR OF SCIENCE: The nest of an English sparrow was broken up, and four fledglings, nearly ready to fly, were thrown to the ground. A blue jay seized on one and devoured it. One young sparrow was then placed in the nest of the blue jay—presumably the same—along with its own young, and was tolerated, but not fed, by the parent jays. On the second day, however, I observed the jay once feed, perhaps by mistake, the sparrow. For two days the parent sparrows watched their chance when the old jays were away from the nest and came hastily and fed their sparrow, but not the young jays. On the third day the young sparrow flew away from the jay's nest.

While a single incident can hardly form the basis for generalization, yet, as has been sug-

gested to me, the origin of rites of hospitality may be hinted at here. A blue jay devours a young sparrow outside its nest, but tolerates and may even adopt the sparrow placed in its nest. Once within the home nest there is a certain hospitality, which biologically means protection to its own young, for the jay might readily acquire a habit of devouring its own young, if the nest-life did not mean protection. We may surmise that the right of hospitality has its biological significance as a home protection act of the greatest service to the species.

The nest was studied through a telescope placed in a window, and as the eye was brought within a few inches of the nest without disturbing the birds, a little foliage having been removed, a very close study was possible. The male often turned food over to the female to be given to the young. With one beakful several young were fed, the beak being thrust far down the throat and a portion of the food pinched off, and then another portion pinched off in another's throat. The *excreta* were constantly removed, in one case the parent taking *excreta* directly issuing from the young. The parent sometimes took *excreta* far into the mouth and held it for some minutes. The jay often stands on the nest half brooding, and in full brooding it slips its feet to the bottom of the nest with exceeding deftness. A common warning cry is sharp metallic mouí, mouí, in energetically producing which the jay sways his body up and down, vibrating its perch. In excitement it pecks aimlessly at its perch.

The telescopic method might well be used in getting complete studies of nest life. From a house window, or from a platform in a tree, a continuous study of nesting could be made and experiments tried for instinct and intelligence. Certainly for psychological study the method is invaluable, since it gives the close unhampered observation of expression which is the only key to the mind of the bird. A binocular magnifying about fifty times would be generally convenient, though higher and lower powers would often be useful. Leaves, etc., which screen the nest at the point desired, should be removed at night. A powerful glass might reveal the home life of eagles, vultures and beasts of prey. As

giving a fascinating ueariness to animals, unconscious of your spying, the telescope is most serviceable in interesting young people.

HIRAM M. STANLEY.

LAKE FOREST, ILL., August 1, 1898.

---

SCIENTIFIC LITERATURE.

*La certitude logique.* Par G. MILHAUD. Paris, Felix Alcan. 1898. Pp. 204.

Those who know what expectations were encouraged by scholastic philosophy would hope for much from a book with the present title, whether it intended to defend or criticise the pretensions that have been associated with the study of logic. The scholastics thought that logic was the source of all certitude in knowledge. The present author's thesis is a denial of this claim. His assertion is that logic cannot give us any certitude beyond particular facts directly observed. This position is based upon the law of contradiction, and the distinction between that which is *given* and that which is *construed*. The author attempts to establish his thesis, first directly, and secondly by an appeal to the testimony of mathematics. In neither of his proofs do I think the author successful in maintaining his position. Not that it is false, but because he has tried to give certitude to a proposition by the very method which he says is incapable of doing it. It is in one aspect of the matter a mere truism that logic cannot give any certitude beyond the facts of individual experience, but is in another relation a very equivocal proposition. It implies that somebody has claimed, or does claim, logic is the source of *all* certitude. In the first place, no one since Descartes has claimed this view. In the second place, all first-class thinkers who have attached any value to logic as a means to certitude of any kind limit it to the proof of doubtful propositions, and do not try to supplant experience of simple facts by it. There is an error on the part of logicians and philosophers here which we had hopes that the author would correct. It is true that much of our psychological analysis and past philosophical speculation gives the impression that ratiocination is the most important and perhaps ultimate process in knowledge, assuming all the while that

as a process it was different from the intuitive. But it is possible to show that ratiocination is only one form of intuition, simply that form which serves as a vehicle for the transmission of certitude from one proposition to another, but it is not the primary organ of rectitude. Here was an opportunity for some good discussion of logical processes, but there is no attempt at it. Practically the only reference to logical methods at all is the enunciation of the law of contradiction. The remainder of the work is occupied with discussion upon the application of mathematics to the sciences, and deals with results, not methods. J. H. HYSLOP.

*Le rational.* Par GASTON MILHAUD. Paris, Felix Alcan. 1898. Pp. 180.

This work is confessedly a supplement to the work on *La certitude logique*. It professes to discuss more fully the rational processes that are supposed to determine logical certitude, but is in most respects subject to the same strictures that we have applied to the former. The author is better acquainted with the material results of the sciences related to his problem than with the issues involved in logical speculation. Only one chapter looks like an approach to the real question, and even this does not exhibit any conception of what the subject demands. The reasoning of mathematics gave the author the intimation of his problem, but he has not studied the formal processes of logic sufficiently to see what they represent. His primary interest is really in the results of the special sciences, and not at all in methodology. The theme is a most important one at the present time, especially as it affords an opportunity to criticise the implications still remaining in general philosophy after the source of them, namely, the old faculty psychology, has passed away. The old distinction between the rational and the perceptive or immediate consciousness which gave rise to the author's problem no longer exists, and we can reconcile logical certitude with all others. J. H. HYSLOP.

*Flore Phanérogamique des Antilles Françaises, Guadeloupe et Martinique.* Par le R. P. DUSS, Professeur au Collège de la Basse-Terre. Macon. 1897. 8vo. Pp. xxviii + 656.

The intention of the author has been to furnish a guide to the rich, tropical flora of the French islands, Guadeloupe and Martinique. He has succeeded well in making the work a manual of these insular floras. In addition to this, he has included a large amount of interesting and useful information upon the distribution, phenology, economic value and uses, folk-lore, etc., of the plants of the flora. This task has been accomplished in such a way as to greatly enhance the scientific value of the volume.

The most interesting part to botanists in general is the introduction, which contains a concise account of the phytogeography of the islands. This includes a sketch of the physiography of the islands, of their climate, with especial reference to humidity, and of the zonal distribution of the plants of the flora. The latter, though touched only in its gross features and treated entirely from the floristic instead of the ecologic aspect, is of importance, since it is the first attempt to portray the zonation of the floral covering of a large island. The author distinguishes five zones, or, as he terms them, regions; a use of the term which should be avoided. These zones may be characterized briefly as follows:

I. Maritime zone. This comprises a narrow strip of the sea, characterized by the presence of numerous algæ and by two aquatic monocotyledons, *Ruppia maritima* and *Thalassia testudinum*.

II. Lowland, or coastal zone. This zone begins at the sea level and stretches to the forests at a mean altitude of 500 meters. It is the cultivated zone, and includes four-fifths of the species of the flora. In it may be distinguished eight formations, viz.: (1) Beach; (2) Halophytic woodland; (3) Savannah; (4) Pond and marsh; (5) Rocky hills and slopes; (6) Calcareous hills; (7) Xerophytic coasts; (8) Cultures.

III. Median, or forest zone. A zone of primitive tropical forest extends from a mean elevation of 500 meters to about 800-1000 meters. The lower layers are characterized by the dominance of Aroidæ, terrestrial Orchidacæ, and species of *Hymenophyllum*, *Trichomanes*, *Lindsaya*, *Asplenium*, *Pteris*, *Polypodium*, *Aspidium*, etc.

IV. Transition zone. This is a narrow stretch, characterized by thickets, marking the transition between the forests and the montane zone.

V. Montane zone. The mountain sides, summits and plateaux possess a floral covering of very sharp delimitation. The shrubs and trees of the two lower zones are replaced by a uniform vegetation of dwarf shrubs and herbs.

\*

#### SCIENTIFIC JOURNALS.

WITH the recent appearance of the July number, the *Bulletin of the American Mathematical Society* completes its seventh annual volume. Founded in 1891 as the *Bulletin of the New York Mathematical Society*, it has long been recognized as the most thoroughly representative mathematical journal of the country. The period of its existence has been coincident with the great wave of mathematical productivity which is still sweeping with constantly increasing energy over America. In this movement the American Mathematical Society and with it the *Bulletin* have taken a conspicuous part. It is largely to the members, individually and collectively, of the Society that the movement is due, and its results have been reflected in their organ, the Society's journal. In its list of contributors are found the names of Simon Newcomb, G. W. Hill, Emory McClintock, E. H. Moore, Thomas Craig, B. O. Peirce, H. B. Fine, W. F. Osgood, M. Bôcher, J. Pierpont, H. S. White and nearly every other American mathematician of standing. The *Bulletin* distributes 450 copies of each number to members of the Society, exchanges and subscribers. The volume just completed, Vol. IV., second series, contains 577 pages.

The July number of the *Bulletin* contains, besides the usual 'Notes' and 'New Publications,' the 'Seventh Annual List of Papers Read before the Society and Subsequently Published,' and the index, the following articles and reviews: 'The Structure of the Hypoabelian Groups,' by Dr. L. E. Dickson; 'On the Hamilton Groups,' by Dr. G. A. Miller; 'Note on the Infinitesimal Projective Transformation,' by Professor E. O. Lovett; 'Infinitesimal Transformations of Concentric Conics,' by Professor



E. O. Lovett; 'A Solution of the Biquadratic by Binomial Resolvents,' by Dr. G. P. Starkweather; 'Note on Special Regular Reticulations,' by Professor E. W. Davis; 'Limitations of Greek Arithmetic,' by Mr. H. E. Hawkes; 'Maxima and Minima of Functions of Several Variables,' by Professor James Pierpont; 'On the Intersections of Plane Curves,' by Mr. F. S. Macaulay; 'Elliott's Algebra of Quantities,' by Professor H. S. White; 'Hadamard's Geometry,' by Professor F. Morley; 'Further Note on Euler's Use of  $i$  to Represent an Imaginary,' by Professor W. W. Beman; and 'Note on Napier's Rules of Circular Parts,' by Professor E. O. Lovett.

---

SOCIETIES AND ACADEMIES.

THE AMERICAN ASSOCIATION FOR THE ADVANCEMENT OF SCIENCE.

WE have on frequent occasions during the past year called attention to the preparations for the anniversary meeting of the American Association which takes place next week at Boston. We now subjoin the programs of the sections, to which undoubtedly important additions will be made at the time of the meeting.

SECTION A.—MATHEMATICS AND ASTRONOMY.

Address of the Vice-President: Development of Astronomical Photography. By Professor E. E. Barnard, Yerkes Observatory.

1. Three Years' Experience in making Astronomy Popular. By Miss Mary Proctor, New York City.

2. Personal Equations during the Past Century. By Professor Truman H. Safford, Williams College, Williamstown, Mass.

3. Triangles whose Sides and Areas are expressed by Whole Numbers. By Professor Truman H. Safford, Williams College.

4. On Rational Right-Angled Triangles. By Dr. Artemas Martin, U. S. Coast Survey, Washington, D. C.

5. Behavior of the Atmospheres of Gas and Vapor—Generating Globes in Celestial Space. By Dr. J. Woodbridge Davis, Woodbridge School, New York City.

6. Graphical Logic. By Professor Ellen Hayes, Wellesley College, Wellesley, Mass.

7. Illustrations of the Comitant Method of constructing the Imaginary Loci of Analytic Geometry, so as to render their Properties evident to the Eye. By Professor Frank H. Loud, Colorado College, Colorado Springs.

8. The Mass and Moments of Inertia of the Earth's Atmosphere. By Professor R. S. Woodward, Columbia University, New York City.

9. A New Form of Pendulum for measuring the Acceleration of Gravity. By Professor R. S. Woodward, Columbia University.

10. The Gravitation Constant and the Mean Density of the Earth. By Professor R. S. Woodward, Columbia University.

11. The Substitution Groups of Order Fifty. By Dr. G. A. Miller, Cornell University, Ithaca, N. Y.

12. Correction of Local Error in Stellar Photometry. By Henry M. Parkhurst, Brooklyn, N. Y.

13. Variation of Latitude and the Constant of Aberration from Observations at Columbia University Observatory, during the years 1892–1898. By Professors J. K. Rees, Harold Jacoby and Dr. H. S. Davis. Read by Professor J. K. Rees, Columbia University Observatory, New York City.

14. Photographic Researches near the Pole of the Heavens. By Professor Harold Jacoby, Columbia University Observatory.

15. The Parallaxes of 61<sup>1</sup> and 62<sup>2</sup> Cygni from a Reduction of the Rutherford Measures. By Dr. H. S. Davis, Columbia Univ. Observatory.

16. The Praesepe Group: Measurement and Reduction of the Rutherford Photographs. By Dr. Frank Schlesinger, Columbia University.

17. The Western Boundary Survey of Maryland. By Dr. L. A. Bauer, University of Cincinnati, Cincinnati, Ohio.

18. Linear Algebras. By Professor James Byrnie Shaw, Illinois College, Jacksonville, Ill.

19. A Simple Test as to whether a Continuous Function possesses a Derivative; with Applications to the Examples, hitherto devised, of Continuous Functions having no Derivative. By Professor R. D. Bohannon, Ohio State University, Columbus Ohio.



20. The Relation of Direct and Reflected Observations with Meridian Instruments, and the Interpretation of Results. By Professor J. R. Eastman, U. S. Naval Observatory, Washington, D. C.

21. The Effect of Atmospheric Disturbance on Telescopic Definition. By Professor G. W. Hough, Dearborn Observatory, Evanston, Ill.

22. The Condition of the Surface of the Planet Jupiter. By Professor G. W. Hough, Dearborn Observatory.

23. The Observation of Occultation of Stars by the Moon. By Professor G. W. Hough, Dearborn Observatory.

24. A Class of Functions connected with Kepler's Problem. By Professor Edgar O. Lovett, Princeton University, Princeton, N. J.

25. On the Aims of the International Society for the Promotion of Quaternions and Allied Branches. By Dr. Alexander Macfarlane, Chatham, Ont.

The following reports on recent progress will be presented:

1. Report on the Recent Progress in the Dynamics of Solids and Fluids. By Dr. Ernest W. Brown, Christ's College, Cambridge, Professor of Applied Mathematics, Haverford College, Pa.

2. Report on Theory of Invariants: the Chief Contributions of a Decade. By Professor Henry S. White, Northwestern University, Evanston, Ill.

3. Report on the Recent Progress in the Mathematical Theory of Electricity and Magnetism. By Professor Arthur G. Webster, Clark University, Worcester, Mass.

4. Report on the Modern Group Theory. By Dr. G. A. Miller, Cornell University, Ithaca, N. Y.

5. Meteorology from a Mathematical and Physical Point of View. By Professor Cleveland Abbe, Weather Bureau, Washington, D. C.

#### SECTION B.—PHYSICS.

Address of the Vice-President: On the Perception of Light and Color. By Professor Frank P. Whitman, Adelbert College, Cleveland, Ohio.

1. The Measurement of Thermal Conduc-

tivity in Iron. By Professor E. H. Hall, Cambridge, Mass.

2. On Energy and Entropy.

3. Second Report on the Magnetic Survey of Maryland. By Professor L. A. Bauer, Cincinnati, Ohio.

4. On the Magnetic Deflection of Diffusely Reflected Cathode Rays. By Professor Ernest Merritt, Ithaca, N. Y.

5. On the Electrical Properties of the Vapor from the Arc. By Professor Ernest Merritt and O. M. Stewart, Ithaca, N. Y.

6. The Heat of Fusion of Ice Determined in Electrical Units. By Professor E. L. Nichols, Ithaca, N. Y.

7. The Hysteresis of Iron and Steel at Ordinary Temperatures and at the Temperature of Solid Carbon Dioxide. By A. H. Thiessen, Ithaca, N. Y.

8. The Electrical Resistance of Lead Amalgams at Low Temperatures. By G. W. Gressman, Ithaca, N. Y.

9. The Most Efficient Thickness of Transformer Plate. By F. Bedell, R. M. Klein and T. P. Thompson, Ithaca, N. Y.

10. The Resistance of Iron Wires for Alternating Currents of Ordinary Frequencies. By Professor Ernest Merritt, Ithaca, N. Y.

11. Photographic Studies of the Electric Arc. By N. H. Brown, Ithaca, N. Y.

12. Exhibition of Certain Models in Physics and Dynamics. By Professor Carl Barus, Providence, R. I.

13. Lightning Photographed on Moving Plates.

14. On the Use of the Electrodynamometer instead of the Telephone in Electrolytic Resistance Measurements. By Professor Arthur Kendrick, Terre Haute, Ind.

15. The Structure of Cyclones and Anticyclones.

16. Temperature and Vapor Gradients in the Atmosphere. By Professor F. H. Bigelow, Washington, D. C.

17. On the Velocity of Light in a Magnetic Field. By Edward W. Morley, Henry T. Eddy and Dayton C. Miller.

18. A Study of Standard Meter Scales ruled on Nickel, Silver and Glass. By Professor D. C. Miller, Cleveland, Ohio.

19. An Apparatus for Demonstrating, in Alternating Currents, the Change of Phase due to either Inductance or Capacity.

20. An Apparatus for Determining Coefficients of Induction. By Professor Sidney T. Moreland, Lexington, Va.

21. Study of Elastic Fatigue by the Time Variation of the Logarithmic Decrement. By Professor J. O. Thompson, Amherst, Mass.

22. A Redetermination of the Ampere. By Geo. W. Patterson and Karl E. Guthe, Ann Arbor, Mich.

23. Polarization and Internal Resistance of the Voltaic Cell. By Dr. Karl E. Guthe, Ann Arbor, Mich.

24. A New Gas. By Chas. F. Brush, Cleveland, Ohio.

25. Hysteresis Loss in Iron for very small Ranges of Induction (B). By Henry S. Webb, South Bethlehem, Pa.

26. Note on the Testing of Optical Glass. By Professor W. S. Franklin, South Bethlehem, Pa.

27. A Lecture-room Experiment in Electrostatics. By Professor W. S. Franklin.

28. A Study of Galvanic Polarization. By Barry McNutt, South Bethlehem, Pa.

29. On a Normal Curve of Magnetization of Iron. By S. S. Clark, South Bethlehem, Pa.

30. Some Determinations of Dielectric Strength. By Professor Thomas Gray, Terre Haute, Ind.

#### SECTION C.—CHEMISTRY.

Tuesday, August 23. (Under the auspices of the American Chemical Society), Morning—Analytical Chemistry, led by Dr. P. DeP. Ricketts, Columbia University. Afternoon—Teaching of Chemistry, Dr. F. P. Venable, University of North Carolina.

Thursday, August 25. Morning—Inorganic Chemistry, led by Dr. H. A. Wells, Yale University. Afternoon—Organic Chemistry, by Dr. Ira Remsen, Johns Hopkins University. Evening—Physical Chemistry, Dr. T. W. Richards, Harvard University.

Friday, August 26. Afternoon (in one of Harvard University rooms)—Physiological Chemistry, led by Dr. E. E. Smith, New York.

Saturday, August 27. Morning—Agricultu-

ral Chemistry led by Dr. H. A. Weber, Ohio University. Afternoon—Technical Chemistry, Dr. N. W. Lord, Ohio State University.

#### SECTION D.—MECHANICAL SCIENCE AND ENGINEERING.

Address of the Vice-President, Professor M. E. Cooley, University of Michigan, Ann Arbor, Mich.

1. High-Speed Influence Machines. By Charles F. Warner, Cambridge, Mass.

2. Proposed Methods of Determining the Frequency of Alternating Currents. By Carl Kinsley, Falls Church, Va.

3. Instruments and Methods of Hydrographic Measurements by the United States Geological Survey. By F. H. Newell, Washington, D. C.

4. The Development of the Topographic Work of the United States Geological Survey and its application to the Solution of Economic and Engineering Problems. By Chas. D. Walcott, Washington, D. C.

5. A new Form of Dynamometer Car. By Professor Lester P. Breckenridge, Urbana, Ill.

6. A Combined Absorption and Transmission Dynamometer. By Professor John J. Flather, Lafayette, Ind.

7. Some Experiments with a New Form of Impact Testing Machine. By Professor W. K. Hatt, Lafayette, Ind.

8. Superheating and the Use of Superheated Steam. By Geo. I. Rockwood, Worcester, Mass.

#### SECTION E.—GEOLOGY AND GEOGRAPHY.

Address of the Vice-President: Glacial Geology in America. By Professor H. L. Fairchild, University of Rochester, Rochester, N. Y.

1. Outline Map of the Geology of Southern New England. By Professor B. K. Emerson, Amherst, Mass.

2. Basins in Glacial Lake Deltas. By Professor H. L. Fairchild, Rochester, N. Y.

3. An Exhibition of the Rare Gems and Minerals of Mt. Mica. By Dr. A. C. Hamlin, Bangor, Maine.

4. The Hudson River Lobe of the Laurentide Ice-sheet. By Professor C. H. Hitchcock, Hanover, N. H.

5. The Age of the Amboy Clay Series as in-

icated by its Flora. By Professor Arthur Hollick, Columbia University, New York, N. Y.

6. The Origin of the Limonite Ores of Nitany Valley, Pennsylvania. By Professor T. C. Hopkins, State College, Pa.

7. The Region of the Causes in Southern France (with maps and stereopticon views). By Dr. Horace C. Hovey, Newburyport, Mass.

8. The Washington Limestone in Vermont. By Professor C. H. Richardson, Hanover, N. H.

9. Fluctuations of North American Glaciation shown by Interglacial Soils and Fossiliferous Deposits. By Warren Upham, St. Paul, Minn.

10. Time of Erosion of the Upper Mississippi, Minnesota and St. Croix Valleys. By Warren Upham.

11. Supposed 'Corduoy Road' of Late Glacial Age, at Amboy, Ohio. By Professor G. Frederick Wright, Oberlin, Ohio.

#### SECTION F.—ZOOLOGY.

Address of the Vice President: A Half-century of Evolution with Special Reference to the Effect of Geological Changes on Animal Life. By Professor A. S. Packard, Brown University, Providence, R. I.

1. Evolution and Migration of Hawaiian Land Shells. By Professor Alpheus Hyatt, Boston Society of Natural History, Boston, Mass.

2. A new Classification of Fossil Cephalopods. By Professor Alpheus Hyatt, Boston Society of Natural History.

3. Notes on the Habits of some Burrowing Bees. By Professor John B. Smith, Rutgers College, New Brunswick, N. J.

4. A New Method of Studying Underground Insects. By Professor John B. Smith, Rutgers College.

5. On the Systematic Position of the Trilobites. By Professor A. S. Packard, Brown University, Providence, R. I.

6. On the Carboniferous Fauna of Rhode Island. By Professor A. S. Packard, Brown University.

7. On the Markings of Nodontian Larvæ. By Professor A. S. Packard, Brown University.

8. Some Points in the Oögenesis of *Virbius zostericola* Smith. By Frederic P. Gorham, Providence, R. I.

9. A Species of Myxosporidium found in

Fishes, in the Aquaria of the U. S. Fish Commission, at Woods Holl, Mass. By Frederic P. Gorham, Providence, R. I.

10. A New Species of Pigment producing Pathogenic Bacillus. By Frederic P. Gorham, Providence, R. I.

11. On the Types of Vertebrate Embryos. By Dr. Charles Sedgwick Minot, Harvard Medical School, Boston, Mass.

12. On the Embryology of the Rabbit. By Dr. Charles Sedgwick Minot, Harvard Medical School.

13. Variation *versus* Heredity. By Professor H. S. Williams, Yale University, New Haven, Conn.

14. The proposed Attempt to introduce *Blasatophora psenes* into California. By Dr. L. O. Howard, U. S. Dept. of Agriculture, Washington, D. C.

15. The Records of 1898 of Broods VII and and XVII of *Cicada septendecim*. By C. L. Marlatt, U. S. Dept. of Agriculture, Washington, D. C.

16. On the Genitalia of Ants, and their Value in Classification. By W. H. Ashmead, U. S. Dept. of Agriculture, Washington, D. C.

17. Naples Station: General Description and Notes on Methods of Work employed there. By Dr. E. O. Hovey, American Museum of Natural History, New York, N. Y.

18. General Statement of Types and Figured Specimens of Fossil Invertebrates in the American Museum of Natural History. By Dr. E. O. Hovey, American Museum Natural History.

19. Measurements of two large Lobsters recently added to the Collections of the American Museum of Natural History. By Dr. E. O. Hovey, American Museum Natural History.

20. On the Present State of our Knowledge of the North American Tertiary Mollusk-fauna. By Dr. Wm. H. Dall, Smithsonian Institution, Washington, D. C.

21. Cranial Osteology in certain species of Dinichthys. By Dr. Charles Rochester Eastman, Museum of Comparative Zoology, Cambridge, Mass.

22. Moniloporidæ, a new Family of Palæozoic Corals. By Amadeus W. Grabau, Cambridge, Mass.

23. A Historical Notice of Ross' Rosy Gull,

*Rhodostethia rosea*. By John Murdoch, Public Library, Boston, Mass.

24. Vein Evolution in Insect Wings. By James G. Needham, Ithaca, N. Y.

25. Localized Stages in Growth. By Dr. Robert T. Jackson, Harvard University, Cambridge, Mass.

26. On the Piscine Ancestors of the Amphibiaus. By Professor Theo. Gill, Columbian University, Washington, D. C.

27. Variation in the Shell of *Helix nemoralis* in the Lexington, Va., Colony. By Professor Jas. Lewis Howe, Washington and Lee University, Lexington, Va.

#### SECTION G.—BOTANY.

Address of the Vice-President: The Conception of Species as affected by Recent Investigations on Fungi. By Professor W. G. Farlow, Harvard University, Cambridge, Mass.

1. Studies on North American Lichens. By Thomas A. Williams, Department of Agriculture, Washington, D. C.

2. The Micro-Chemistry of the Cornstalk. By Thomas A. Williams.

3. The Effect of an Atmosphere of Ether upon Seeds and Spores. By C. O. Townsend, Barnard College, New York City.

4. Half Shade and Vegetation. By Byron D. Halsted, New Jersey Agricultural Experimental Station, New Brunswick, N. J.

5. Influence of a Wet Spring on Parasitic Fungi. By Byron D. Halsted.

6. Starch Distribution as affected by Fungi. By Byron D. Halsted.

7. The Carposporic Type of Reproduction of Rhodophyceæ. By Bradley M. Davis, University of Chicago, Chicago, Ill.

8. Notes on the Relative Infrequency of Fungi upon the Trans-Missouri Plains and the Adjacent Foothills of the Rocky Mountains. By Charles E. Bessey, University of Nebraska, Lincoln, Neb.

9. The Comparative Anatomy of the Pistils of Apocarpous Families. By Ernest A. Bessey.

10. Origin and Homologies of Blepharoplasts. By Herbert J. Weber, Dep. Agric., Washington, D. C.

11. Notes on the Strand Flora of Florida (lantern slide lecture). By Henry J. Weber.

12. Some Misuses of the Herbarium. By E. L. Greene, Catholic University of America, Washington, D. C.

13. The Advantages offered by the Philadelphia Commercial Museum to Botanists. By Wm. P. Wilson, Director, Philadelphia, Pa.

14. Notes on Arctic Willows. By W. W. Rowlee, Cornell University, Ithaca, N. Y.

15. On the Hypocotyl of Woody Dicotyledonous Plants. By Francis Ramaly, University of Colorado, Boulder, Col.

16. The Quantitative Analysis of the Floral Covering. By Roscoe Pound and Frederic E. Clements, University of Nebraska.

17. Some Investigations bearing upon the Symbiotic Microplasm Theory of Grain Rust. By Henry L. Bolley, North Dakota Experimental Station, Fargo, N. Dakota.

18. The Work performed by the Agricultural College toward a Botanical Survey of Michigan. By W. J. Beal, Agricultural College, Ingham Co., Michigan.

19. Some Examples Illustrating Modes of Seed Dispersion. By W. J. Beal.

20. Notes on the Physiology of the Sporophyte of Certain Mosses. By Rodney H. True, Wingra Park, Madison, Wis.

21. The Toxic Action of a Certain Group of Compounds. By Rodney H. True.

22. Types of Vegetation on the Keys of South Florida. By Charles Louis Pollard, Washington, D. C.

23. On the Validity of the Genera *Senna* and *Chamæcrista*. By Charles Louis Pollard, National Museum, Washington, D. C.

24. Species Characters among the Violets. By Charles Louis Pollard.

25. Potato as a Culture Medium, with some Notes on a Synthesized Substitute. By Erwin F. Smith, Department of Agriculture, Washington, D. C.

26. Some Little-used Culture Media which have proved Valuable for Species Differentiation. By Erwin F. Smith.

27. Plant Growth in Terms of Climatology. By Milton Whitney and Lyman J. Briggs, Department of Agriculture, Washington, D. C.

28. Effect of Fertilizers on the Germination of Seeds. By Gilbert H. Hicks, Department of Agriculture, Washington, D. C.



29. Development of the Pollen Grain in *Symplocarpus* and *Peltandra*. By B. M. Dugger, Cornell University, Ithaca, N. Y.

30. Fermentation without Live Yeast Cells. By Katherine E. Golden, Lafayette, Ind., and Carleton G. Ferris.

31. Deterrent Action of Salt in Yeast Fermentation. By Katherine E. Golden.

32. Fungus Gardening as practiced by the Termites in West Africa and Java. By O. F. Cook, U. S. National Museum, and D. G. Fairchild, Department of Agriculture, Washington, D. C.

33. The Embryology of *Taxus*. By E. J. Durand, Cornell University, Ithaca, N. Y.

34. A Bacteriological Study of Pear Blight. By Lillian Snyder, Lafayette, Ind.

35. Life History and Characteristics of the Pear Blight Bacillus. By Merton B. Waite, U. S. Department of Agriculture.

36. Notes on Some Diseases of Southern Pines. By Hermann von Schrenk, Missouri Botanic Garden, St. Louis, Mo.

37. The Ecological Distribution of Colorado and Wyoming Plants. By L. H. Pammel, Ames, Ia.

38. Notes on Some Monocotyledonous Embryo-sacs. By K. M. Wiegand, Cornell University, Ithaca, N. Y.

39. General Characteristics of the Dune Flora of Southeastern Virginia. By Thos. H. Kearney, Jr., U. S. Department of Agriculture, Washington, D. C.

40. Vegetation of the Wooded Fresh-water Swamps of Southeastern Virginia. By Thos. H. Kearney, Jr.

#### SECTION H.—ANTHROPOLOGY.

Address of the Vice-President: The Advance of Psychology. By Professor J. McKeen Cattell, Columbia University, New York.

1. Typological Analysis. By Professor D. G. Brinton, University of Pennsylvania.

2. Anthropological Terminology. By Professor D. G. Brinton.

3. Sophiology, or the Science of the Evolution of Opinion. By Major J. W. Powell, Bureau of American Ethnology, Washington, D. C.

4. Papago Medicine. By Dr. W J McGee,

Bureau of American Ethnology, Washington, D. C.

5. Some Definitions in Anthropology. By Dr. W J McGee.

6. Anthropological Problems of the Pacific Slope. By Dr. W. H. Holmes, U. S. National Museum.

7. Museum Presentation of Anthropology. By Dr. W. H. Holmes.

8. The Significance of the Garment, a Study of the Omaha Tribe. (Lantern illustrations.) By Miss Alice C. Fletcher, Washington, D. C.

9. The Earth Lodge. By Miss Alice C. Fletcher and Dr. W. Matthews, Washington, D. C.

10. The Harmonic Structure of Indian Songs. By Professor J. C. Fillmore, Pomona College, Claremont, California.

11. Ritual of the Sacred Pole of the Omahas. (Phonograph records.) By Francis La Flesche, Washington, D. C.

12. The Survival of African Music in America. By Mrs. Jeanette Robinson Murphy, New York, N. Y.

13. Some of the Evidences that Northmen were in Massachusetts in pre-Columbian Times. By Miss Cornelia Horsford, Cambridge, Mass.

14, 15. Subjects relating to the Physical Anthropology of North American Indians. By Dr. G. A. Dorsey, Field Columbian Museum, Chicago, Ill.

16. The Smith Sound Eskimo. By A. L. Kroeber, Columbia University.

17. The Maori of New Zealand; his history and country. By Hon. Hugh H. Lusk, England.

18. 'Moros,' or Malay Pirates of the Southern Philippines. By Professor Dean C. Worcester, University of Michigan, Ann Arbor, Mich.

19. The Philippine Islands and their People. By Professor Dean C. Worcester.

20. The Tools of the American Pioneer. (Lantern illustrations.) By H. C. Mercer, University of Pennsylvania, Philadelphia, Pa.

21. The Origin of Domesticated Animals. By H. C. Mercer.

22. Burial Customs of the Ancient Zapotecs of Southern Mexico. By M. H. Saville, American Museum of Natural History, New York.

23. Notes on the Lacandon Indians of Mexico. By M. H. Saville.

24. Tomahawk and Shield. By Frank H.

Cushing, Bureau of American Ethnology, Washington, D. C.

25. Examples of Primitive Fire-working from Florida. By Frank H. Cushing.

26. Art in Prehistoric Times. By Professor Thomas Wilson, Smithsonian Institution, Washington, D. C.

27. Prehistoric Musical Instruments. By Professor Thomas Wilson.

28. Arrow-points, Spear-heads and Knives. By Professor Thomas Wilson.

29. Problems of the Rechahecrian Indians of Virginia. By William Wallace Tooker, Sag Harbor, N. Y.

30. The Swastica and other Marks among the Eastern Algonquians, a preliminary study. By William Wallace Tooker.

31. The Water Burial Time. By Stansbury Hagar, New York.

32. Relation of the Moon to Time-reckoning among the Early Races. By R. J. Floody, S. Ashburnham, Mass.

33. The Rite of Circumcision among the Early Races. By R. J. Floody.

34. Anthropology, not Sociology, as an Adequate Philosophy. By Daniel Folkmar, Milwaukee, Wis.

35. Science the Basis of Morals. By M. A. Clancey, Clerk's Office, Supreme Court, Washington, D. C.

36. Anthropological Differences between Typical White and Negro Girls of the same Age. By Dr. A. Hrdlicka, State Pathological Institute, New York.

37. Variations of the Normal Tibia. By Dr. A. Hrdlicka.

38. Résumé of Recent Studies on the Origins of European Races. By Dr. W. Z. Ripley, Massachusetts Institute of Technology, Boston, Mass.

39. Presentation of a Bibliography of the Anthropology and Ethnology of Europe. By Dr. W. Z. Ripley.

40. Typical American Students, illustrated by Charts and Statues. By Dr. D. A. Sargent, Hemenway Gymnasium, Harvard University, Cambridge, Mass.

41. A New Kymographion; a New Chronoscope. Professor G. W. Fitz, Harvard University, Cambridge Mass.

42. Anthropometric Instruments. By Pro-

fessor J. McKeen Cattell, Columbia University, New York.

43. Psychology and Art. By Professor Hugo Münsterberg, Harvard University, Cambridge, Mass.

44. The New Theory of the Light Sense. By Mrs. C. Ladd Franklin, Baltimore, Md.

45. Discussion: In Man, what Factors are due to Heredity and what to Environment? Opened by Professor D. G. Brinton, Dr. W. J. McGee and Dr. W. Z. Ripley.

#### SECTION I.—SOCIAL AND ECONOMIC SCIENCE.

Address of the Vice-President: The Historic Method in Economics. By Archibald Blue, Director, Bureau of Mines, Toronto, Ontario.

1. The College of Forestry at Cornell University. By B. E. Fernow, Cornell University, Ithaca, N. Y.

2. High Wages in Money or what Money will buy, the Consequent of Low Cost of Production. By Edward Atkinson, Boston, Mass.

3. Local Life by Local Times. By S. Edward Warren, Newton, Mass.

4. A Study of Competition and Suburban Prices. By S. Edward Warren.

5. Executive Discretion in the United States. By Cora A. Benneson, Cambridge, Mass.

6. The Short Duration of School Attendance, Causes and Remedies. By Mr. and Mrs. Daniel Folkmar, State Normal School, Milwaukee, Wis.

7. The Progress of the Maritime Commerce of the World during the past Fifty Years. By E. L. Corthell, New York, N. Y.

8. Cuba, Past, Present and Future. By Wolford Nelson.

9. Examination of the Theory of Rent. By Edward T. Peters, Washington, D. C.

10. The Price of Wool. By Henry Farquhar, Department of Agriculture, Washington, D. C.

11. The Transportation Problem. By John S. Willison.

12. The Formative Period of a Great City: A Study of Greater New York. By William H. Hale, Brooklyn, N. Y.

13. Deviations from the Normal in the Annual Rate of Agricultural Production. By John Hyde, U. S. Department of Agriculture.

14. Competition and Railway Rates. By H. T. Newcomb, Department of Agriculture.

# SCIENCE

EDITORIAL COMMITTEE: S. NEWCOMB, Mathematics; R. S. WOODWARD, Mechanics; E. C. PICKERING, Astronomy; T. C. MENDENHALL, Physics; R. H. THURSTON, Engineering; IRA REMSEN, Chemistry; J. LE CONTE, Geology; W. M. DAVIS, Physiography; O. C. MARSH, Paleontology; W. K. BROOKS, C. HART MERRIAM, Zoology; S. H. SCUDDER, Entomology; C. E. BESSEY, N. L. BRITTON, Botany; HENRY F. OSBORN, General Biology; C. S. MINOT, Embryology, Histology; H. P. BOWDITCH, Physiology; J. S. BILLINGS, Hygiene; J. McKEEN CATTELL, Psychology; DANIEL G. BRINTON, J. W. POWELL, Anthropology.

FRIDAY, AUGUST 26, 1898.

ADDRESS OF THE PRESIDENT BEFORE THE  
AMERICAN ASSOCIATION FOR THE AD-  
VANCEMENT OF SCIENCE.\*

## CONTENTS:

<i>Address of the President before the American Association for the Advancement of Science:</i> PROFESSOR WOLCOTT GIBBS.....	233
<i>A Half Century of Evolution, with Special Reference to the Effects of Geological Changes on Animal Life:</i> PROFESSOR ALPHEUS S. PACKARD.....	243
<i>Botanical Notes:—</i>	
<i>Asparagus Rust; Poisonous Plants; Edible and Poisonous Fungi:</i> PROFESSOR CHARLES E. BESSEY.....	257
<i>Current Notes on Meteorology:—</i>	
<i>Report of the Chief of the Weather Bureau; The Mauritius Observatory; West Indian Hurricanes:</i> R. DEC. WARD.....	259
<i>Current Notes on Anthropology:—</i>	
<i>Pygmy Tribe in America; The Turanians Again; The Influence of Cities in Modern Life:</i> PROFESSOR D. G. BRINTON .....	260
<i>Scientific Notes and News:—</i>	
<i>Degrees Conferred by the University of Edinburgh; General .....</i>	261
<i>University and Educational News .....</i>	265
<i>Discussion and Correspondence:—</i>	
<i>An American Blue Grotto: DR. H. CARRINGTON BOLTON. The Delusion of Atavism: F. A. L.....</i>	266
<i>Scientific Literature:—</i>	
<i>Lafar's Technical Mycology: PROFESSOR H. L. RUSSELL. Anderson on Extinct Civilizations of the East: PROFESSOR D. G. BRINTON. Davies' Nests and Eggs of North American Birds: F. A. L.....</i>	267
<i>New Books.....</i>	268

THE time-honored custom of our Association makes it incumbent upon the retiring President to deliver an address upon some subject connected, if possible, with his own work, and not purely elementary or historical, but with at least some fresh ideas and some new facts. The task is a difficult one for a chemist, for there is perhaps no branch of science in which, of late years, there has been so much mental activity, and it is hard to find any subject which has not been worn threadbare in discussion.

Trusting to your indulgence, I will here present some theoretical points connected in part with my own work, and will treat them as briefly as the nature of the subjects will permit.

All chemists are familiar with the terms atom and molecule. The use of these two words, with a clear conception of their meaning, forms an era in the history of the science. Our modern chemistry is built up of atoms and molecules, as we now define them. Our modern physics deals for the most part and, as I think, too exclusively with atoms, except, perhaps, in the case of what we now term physical chemistry, the new branch of science, which makes it difficult for us to determine where chemistry

MSS. intended for publication and books, etc., intended for review should be sent to the responsible editor, Professor J. McKeen Cattell, Garrison-ou-Hudson, N. Y.

\*Delivered before the Boston meeting, August 22, 1898.

leaves off and where physics begins. The old controversy between the advocates of the continuity and those of the discontinuity of matter is not dead, but only sleeps.

It must be admitted that the conception of the atom, as at present received, is not without serious objections, and probably many accept it as presenting fewer difficulties than the theory of continuity. I venture to suggest that the idea of a material-limit, like that of space or quantity in mathematics, avoids at least some difficulties, so that we may define an atom as a limit to which we approach as we subdivide a given mass of any element, having reference to properties alone. Or, taking a somewhat different mathematical conception, we may consider atoms as material differentials of which the general integrals which we term masses are made up, and in this way we may connect purely material with purely mathematical conceptions. The conception of a limit or of a differential avoids all hypotheses as regards form as well as regards magnitude, and retains only ideas of mass and kind. Conversely, I doubt whether, for the purpose of instruction in the calculus, any purely mathematical conception of limits or of differentials and integrals gives as clear an idea of these as does the comparison with physical or chemical atoms and their aggregates.

As all chemists know, we owe to Dalton the first clear conception of the chemical atom as distinguished from the atoms of Leucippus and Democritus; to Frankland the conception of valence which shows us what combinations of atoms can exist consistently with the number of units of affinity possessed by each individual atom, or, in other words, in what manner groups of atoms can form systems which are in stable equilibrium. This conception includes that of the chemistry of space, now so much employed in organic chemistry, as well as that of the motions of atoms within the molecule,

as yet almost without supporters. To the conception of a definite number of units of affinity recent chemistry has added that of direction of action, statical according to one school of chemists, dynamical according to another.

Within a comparatively short time attention has been directed to a large class of compounds exhibiting very interesting properties and forming peculiar series, some of which, at least, are made up of homologous terms. This group has been called complex-inorganic, because many of its members form highly complex molecules of which no analogues are known.

I may here remark that Ostwald uses the term 'complex' to denote only those molecules or groups of associated atoms which are unitary and do not belong to the class of double salts. I have not drawn this distinction in the present paper, because it is not that which was originally proposed, and because at present we are not able to separate the two classes from each other, except in a very limited number of cases.

No one class of compounds appears so well adapted to throw light upon the structure and modes of combination of molecules. For this reason I have selected the group as the subject of my address to-day.

In endeavoring to establish a plausible theory of the constitution of the complex-inorganic acids and their salts it will be advantageous to state first succinctly the principal facts to be explained. These, I think, are as follows:

1. The teroxides of molybdenum and tungsten possess, in a remarkable degree, what may be termed a 'cumulative' character, each being capable of forming series of salts which contain a very large relative number of molecules of the teroxide. In this respect they stand alone, so far at least as our present knowledge extends. Certain other oxides share in this peculiarity to a



much less degree, as, for example, chromic and perhaps uranic oxides.

I will cite, in the first place, the series of metatungstates, the existence of which has, I believe, been fully established, partly by the researches of other chemists and partly by those made in my own laboratory.

The first term in the series has the general formula  $RO.4WO_3$ ; the highest appears to be represented by the formula  $11RO.24WO_3$ . These, with the intermediate compounds, form a series of homologous terms, the common difference being  $RO.2WO_3$ .

Molybdenum forms a similar, but, in the present state of our knowledge, not so fully represented series. Moreover, in this case, it seems necessary to assume that certain metamolybdates contain a greater or less number of molecules of water as base, either partly or wholly replacing fixed oxides. In my first paper I have discussed this subject, and may here refer to that paper for necessary details. A revision of the composition of the alkaline molybdates is much to be desired, taking specially into account the number of molecules of water retained at high temperatures.

I may here remark that my views in regard to the existence of special classes of metatungstates and metamolybdates have not only not found acceptance with other chemists, but, so far as I know, have never even attracted attention

2. Two different metatungstates may unite to form a double salt, as, for instance,

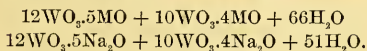

Such compounds, however, are not numerous, and it is possible to explain their structure in other ways. Similar molybdates have not been observed, except in cases in which other oxides, as, for instance, platonic oxide, are present.

3. Metatungstates and metamolybdates

may react with a great variety of other salts to form complex salts in which a relatively very large number of molecules of tungstic or molybdic oxides appear, as compared with the number of molecules of the combined salt or oxide.

4. Metatungstates or metamolybdates may unite with complex salts containing tungstic or molybdic oxides, as, for example,

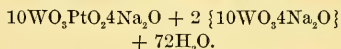

5. Complex acids in the molecule which is united with the tungstic or molybdic oxide appear not to lose their special characters and, in many cases, though not in all, to retain their basicity. Thus in the phospho-tungstate  $12WO_3PO_4H_3$  the phosphoric acid is still ortho-phosphoric acid. Two different oxides, acids or salts may unite with tungstic or molybdic oxide, each retaining its own character. I will cite only the phosphoro-phospho tungstate.

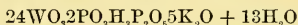

and the arsenoso-phospho-tungstate

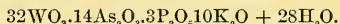

Classes of salts have been described in which ortho-phosphoric, hypo-phosphorous, phosphorous, pyro-phosphoric, mono-metaphosphoric and hexa-metaphosphoric molecules appear as such.

The first of the formulas above given may be written

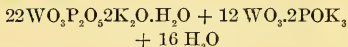

and will represent a quadruple salt if each term is to be considered as representing a double salt.

6. In the great majority of cases the number of molecules of water in the meta-salts as well as in their derivatives is extraordinarily large, but in the present state of our knowledge we are unable to distinguish with certainty between water of constitution and water of crystallization.

In considering the theory of the complex inorganic acids it will be most advantageous to begin with the group of silico-tungstates discovered by Marignac. Of these there are four classes, two of which are isomeric. We may write the general formulas of the neutral salts as follows, omitting water of crystallization :

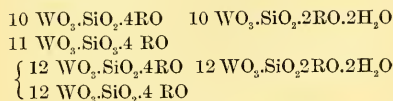

It is, of course, possible that the second group, containing eleven molecules of tungstic oxide, may have twice the molecular mass given, so that the general formula is :

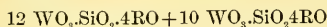

The potassic salt, which is the only one described by Marignac, will then be the analogue of the double sodium and zinc metatungstate, which I have described, and which has, at least probably, the formula :

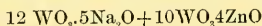

Taking now the first series or group, the general term may be written in one of several ways, as, for example :

- (1)  $10\text{WO}_3 \cdot \text{SiO}_2(\text{RO})_4$
- (2)  $10\text{WO}_3 \cdot \text{RO} + \text{SiO}_2(\text{RO})_3$
- (3)  $10\text{WO}_3 \cdot 2\text{RO} + \text{SiO}_2(\text{RO})_2$
- (4)  $10\text{WO}_3 \cdot 3\text{RO} + \text{SiO}_2\text{RO}$
- (5)  $10\text{WO}_3 \cdot 4\text{RO} + \text{SiO}_2$

Formulas (1) and (2) appear to be excluded by the fact that silicates of the forms  $\text{SiO}_2(\text{RO})_4$  and  $\text{SiO}_2(\text{RO})_3$  are not known to exist, the only forms of silicic acid occurring in silicates containing a single base, in other words, in single as distinguished from double salts, being metasilicic acid  $\text{SiO}_3\text{H}_2$  and ortho-silicic acid  $\text{SiO}_4\text{H}_4$  or  $\text{SiO}_2\text{H}_2\text{O}$  and  $\text{SiO}_2\text{H}_2\text{O}$  or corresponding salts. On the other hand, formulas (3)

and (4) are admissible so far as the silica is concerned, but considered as double salts they require us to assume the existence of  $10 \text{ WO}_3 \cdot 2\text{RO}$  and  $10 \text{ WO}_3 \cdot 3\text{RO}$ , which are not known to exist. Formula (5) is also admissible, if we suppose that a molecule of water is present, and thus we have  $10 \text{ WO}_3 \cdot 4\text{RO} + \text{SiO}_2 \cdot \text{OH}_2$ .

Marignac considered all the acids of this series as quadribasic and consequently that two molecules of basic water were present in each of a number of well defined salts.

From the above it appears difficult to explain the constitution of the various silico-tungstates and tungsto-silicates if we consider them as simply double salts. We must assume either that tungstates not known to exist or that silicates which have no analogues or that both these classes enter together into the structure of the complex molecules.

We get no assistance from a consideration of the mode of preparation of the complex salts in question. Marignac obtained them by boiling gelatinous silica with metatungstates. Gelatinous silica has no definite constitution, but appears to be simply a mixture of two or more forms of silicic acid. It has not been shown, I believe, that soluble alkaline silicates dissolve tungstic oxide on boiling, but Parmentier found that silico-molybdates are formed by the action of alkaline silicates upon alkaline molybdates in presence of silicic acid, and Pechard has shown that a silico-molybdate of the twelve molecule series is formed by the action of fluosilicic acid upon the 14:6 metamolybdate of ammonium.

The same reasoning applies to the silico-tungstates and tungsto-silicates, which contain twelve molecules of tungstic oxide, since the last named classes of acids also unite with four molecules of base.

In this connection three remarkable double salts deserve notice. These have respectively the formulas:

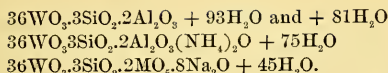

These salts may all be considered as containing three molecules of the complex :

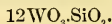

The two first may be, respectively :

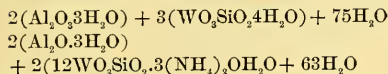

and the third :

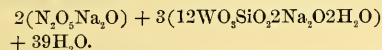

The following also deserve notice in the same connection :

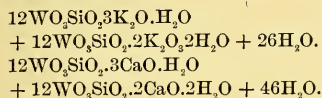

The simplest view which can be taken of all these compounds is that they contain the complex  $12\text{WO}_3 \cdot \text{SiO}_2 \cdot 4\text{RO}$  and that they are double and not quadruple salts or acids. And it seems to me that the weight of evidence is in favor of the view that the complex  $\text{WO}_3 \cdot \text{SiO}_2 \cdot 4\text{RO}$  or  $10\text{WO}_3 \cdot \text{SiO}_2 \cdot 4\text{RO}$  is single or unitary and not a double salt of a tungstate and silicate.

Marignac did not attempt to explain the isomerism of silico-tungstic and tungsto-silicic acids, and the problem is one of much interest, since there are no allotropic modifications of tungsten or silicon.

To obtain a further insight into the constitution of the simpler complex acids we may, with advantage, also consider the cases of the phosphotungstates and phosphomolybdates. As normal we may take the acids  $12\text{WO}_3 \cdot \text{PO}_4\text{H}_3$  or  $12\text{MoO}_3 \cdot \text{PO}_4\text{H}_3$ . These correspond to the twelve molecule silico tungstates or tungsto-silicates of Marignac, and the reasoning applied to these

cases will apply also to the phosphotungstates and phosphomolybdates. Only in these last the number of known compounds is much greater, acids in which the proportion of tungstic or molybdic oxide to phosphoric oxide is as 24:1, 22:1, 20:1, 18:1, 16:1, 5:1, being known in their corresponding salts. Besides these we have arsenic compounds in which the ratio of tungstic or molybdic oxide to arsenic oxide is as 6:1 and 7:1, as well as double salts in the ordinary acceptance of the term. Instances of these last are :

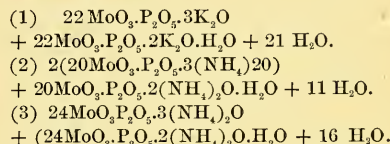

Upon any other than the view which I have taken the phosphotungstates and phosphomolybdates of the types  $n\text{WO}_3 \cdot \text{P}_2\text{O}_5 \cdot 6\text{RO}$  and  $n\text{MoO}_3 \cdot \text{P}_2\text{O}_5 \cdot 6\text{RO}$  are salts *sui generis* analogous to metatungstates and metamolybdates. The compounds expressed by these last formulas are quaternary.

We may compare these salts (1), (2) and (3) with the double tungstate

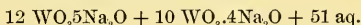

They behave like salts of meta-tungstates or meta-molybdates which have taken into their structure molecules of phosphoric or arsenic oxides without materially changing their general character. The precise mode of combination of the tungstic and molybdic molecular masses with silica, phosphoric or arsenic oxides is not at present known, but it is not difficult to show that the units of affinity of all the elements present may be accounted for and illustrated by structural diagrams. In like manner, the condensation of  $n$  molecules of tungstic or molybdic teroxide is easily explained, the number of unsaturated or residual units of affinity

being for all values of  $n$  equal to 2, as in the case of water.\*

The study of the complex acids which contain ortho-phosphoric acid as such naturally led to that of complex acids containing other acids of phosphorus. The greater number, or at least the more important, of these have been shown to give well-defined complex acids, and in all cases appeared to contain the phosphorus compound in the modification in which it existed before the combination with tungstic or molybdic oxide. Since this work was completed several new acids containing phosphorus have been discovered, more especially the so-called hypo-phosphoric acid, and it is to be hoped that these also will be studied from the same point of view. I shall ask attention to the compounds now known. The only pyrophospho-tungstates yet observed belong to the general types for the acids

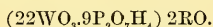

and for the salts

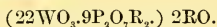

The salts containing molybdic teroxide differ from the above and belong to different types. All those which were examined contained manganous oxide and all contained but two molecules of pyrophosphoric acid or corresponding pyrophosphates in place of nine. It is not easy to see how the presence of manganous oxide as base can affect the formation of such salts, but the analyses of a pyrophospho-tungstate containing six molecules of manganous oxide correspond very closely to a formula embraced under the type

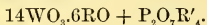

so that, so far as the empirical constitution is concerned, the salt may be regarded as double and as containing two salts belonging to well known types. In the present

\*See *American Journal of Science and Arts*, Vol. XLIV., November, 1867.

state of our knowledge it seems more probable that the pyrophospho-tungstates and pyrophospho-molybdates are double salts belonging to the second class of complex inorganic salts. The solutions of the alkaline salts give, with solutions of the heavy metals, precipitates which contain only pyrophosphoric acid and neither tungsten nor molybdenum. On the other hand, it is well worthy of notice that the group



is capable of existing independently of tungstic oxide. Wallroth has shown that we have salts of the type

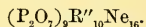

Of the other modifications of phosphoric acid I shall notice only the mono-metaphosphates and the hexa-metaphosphates. In the case of the former the type of the tungsten compounds is :



As in the case of the pyrophospho-tungstates we have here to distinguish an internal and an external basicity, the group  $(m\text{WO}_3, 2\text{PO}_3, \text{R})$  standing in the relation of a complex oxide to the external group  $p\text{R}'\text{O}$ . For the mono-meta-phosphomolybdates the type is different :

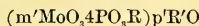

and, of course, other types are possible. So far as we can now judge the salts containing mono-meta-phosphoric acid belong to the first group like phosphotungstates and phosphomolybdates of the type

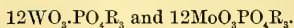

They give no reactions characteristic of their constituents, but the precipitates which they form with metallic salts have the oily or pasty character of the salts of metaphosphoric acid.

The only hexa-metaphosphomolybdate examined has the formula



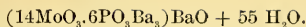

and we may safely infer that the type is



there being an internal and external basicity, as in the cases above noted.

It is worthy of note that in all the known acids containing phosphorus in some oxidized form other than orthophosphoric acid the number of molecules of the acid united to tungstic or molybdic oxide is greater than in the ortho-phosphotungstates or ortho-phosphomolybdates containing an equal number of molecules of tungstic or molybdic oxides.

Two classes of phosphorus compounds remain to be considered—those which contain phosphorous and those which contain hypophosphorous acid or corresponding salts. Chemists are not wholly agreed as to the rational constitution of either of these acids, but it is perhaps more probable that the phosphorous molecule is represented by the formula

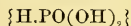

and the hypophosphorous molecule by the formula

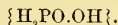

The typical formula for salts containing the former is

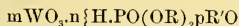

or  $m'\text{MoO}_3.n'\{\text{H}_2\text{PO}(\text{OR})_2\text{pR}'\text{O}.$

and for those which contain the hypophosphorous molecule

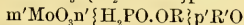
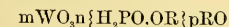

Both groups of salts appear to belong to the first class of complex acids or salts. It is worthy of notice that the phosphorous and hypophosphorous salts do not reduce copper from its solutions even on boiling, and they can, therefore, hardly be supposed to be simply double salts in the ordinary acceptance of the term.

We owe to Blomstrand the discovery of a specially remarkable and interesting class of complex acids, the molybdo-periodates or, in the notation which is more commonly used, periodo-molybdates. The acid of this series has the formula :

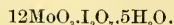

and is the analogue of phosphomolybdic acid.

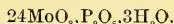

The salts of this series are 5-basic, but, as in the case of metatungstates and metamolybdates, these are composed of two or more normal salts. The best defined of these has the formula :

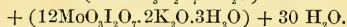
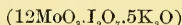

which we may compare with

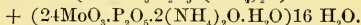
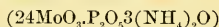

In the complex acids, of which the present paper treats, we may consider the teroxides of tungsten and molybdenum as the determinants. Oxides, of which  $\text{SiO}_2$ ,  $\text{P}_2\text{O}_5$ ,  $\text{R}_2\text{O}_3$  and  $\text{I}_2\text{O}_7$ , may serve as types, may be regarded as sub-determinants. The chemical potential of the compound will, of course, be a function of the chemical potentials of both determinants and sub-determinants. Protoxides appear not to form sub-determinants, but in all cases to act simply as bases. One of the difficulties of our subject consists in determining how far the sub-determinants proper may act as bases, and especially whether they are not sometimes partly bases and partly sub-determinants in the same salt.

In my published paper I have made two assumptions as regards the rôle of vanadic pentoxide in the vanadio-tungstates and vanadio-molybdates.

The first is that  $\text{V}_2\text{O}_5$  may replace  $\text{WO}_3$  so that chemically

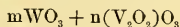

may act as a whole; the second that  $V_2O_5$  may form combinations with a number of molecules of tungstic or molybdic teroxide analogous to phosphotungstates or phosphomolybdates. These assumptions, taken separately or together as the case may require, in many cases at least reduce complex to simple formulas perfectly comparable to those of salts containing phosphoric or arsenic pentoxide. Thus we have

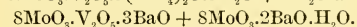
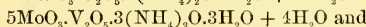
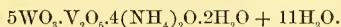

In addition I have described two vanadotungstic acids having respectively the formulas:

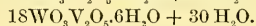
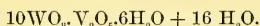

The existence of these compounds has been denied,\* but I see no sufficient reason for rejecting the formulas, which at least closely correspond to the analyses. The same remark applies to the acid

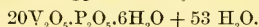

or

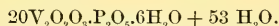

which I would compare with

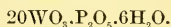

It must be admitted, however, that in view of the extraordinary number and variety of the combinations of vanadic pentoxide with bases it cannot be denied that there are very numerous compounds of this oxide with the teroxides of tungsten and molybdenum, which, in the present state of our knowledge, must be classed as double salts. The empirical composition of these salts may be expressed by the general formula:

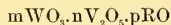

or

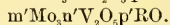

\* See Friedheim. *Berichte*, Band XXIII., p. 1505 and 1530 (and Rosenheim Dissertation, Berlin, 1888); *Zeitschrift für organ. Chemie*, Band V., p. 437; *Berichte*, Band 24, p. 1173.

in which  $m, m'$  represent respectively the number of molecules of tungsten or molybdenum and  $n, n', p, p'$  are whole numbers. Friedheim assumes that in many of these compounds vanadic pentoxide acts as a base and that in others mixtures of isomorphous salts are present. The pentoxide dissolves readily in the stronger acids, as, for instance, in sulphuric and phosphoric acids, but I am not aware that well defined crystalline salts of this oxide have been obtained. There are also, I believe, no known instances of isomorphism between tungstic and vanadic or molybdic and vanadic oxides. In spite, therefore, of all that has been done, it seems necessary to admit that our knowledge of the vanadio-tungstates and vanadiomolybdates is still very imperfect, but this remark applies also to the very large group of alkaline vanadates.\* Of course, the theory that in the salts in question we are dealing, chiefly at least, with double salts is that which would naturally present itself first, but we meet with the difficulty that the constituents of these double salts are themselves double salts, so that we must deal in fact with triple and quadruple salts.

In my view the acids or salts which are usually termed complex may be divided into two classes.

Class first embraces those in which the union of the determinant and sub-determinant is so complete that the special characters of the constituents are nearly or wholly lost. The salts of this class are not decomposed by solution. They may be compared to certain so-called double cyanides, as, for example, to ferrocyanides and cobaltcyanides. The acids  $12WO_3 \cdot PO_4H_4$  and  $12MoO_3 \cdot PO_4H_3$  are examples.

Class second embraces double salts proper which are decomposed by solution alone and which contain two different constituents. Salts of this class are very numerous, and there are probably various sub-classes.

\* See *Proceedings of Am. Acad.*, Vol. XVIII., p. 74.

In the present state of our knowledge it is not possible for us to assign to more than a few acids the classes to which they belong, and a vast field of chemico-physical work is open to the investigation of this subject alone.

We have also to determine by methods now well known to chemists the molecular masses of metatungstates and metamolybdates and of the complex inorganic acids, which may be considered as derived from, or at least as definitely related to them. Certain double salts appear to be composed of metatungstates or metamolybdates united to salts containing subdeterminants, as, for instance, and more especially, platinic oxide. I may, for the sake of clearness, refer to such formulas as

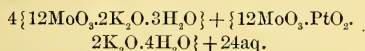
$$10 \text{WO}_3 \cdot 4\text{Na}_2\text{O} + 10 \text{WO}_3 \cdot \text{PtO}_2 \cdot 5\text{Na}_2\text{O} + 58\text{aq. and}$$

These salts appear not to be decomposed by water and to belong therefore to class first.

The compounds of arsenic oxide with tungstic and molybdic oxides closely resemble those of phosphoric oxide and do not now require special notice as regards their structure and properties, nor as to the question of their position as unitary or double salts.

On the other hand, the salts which contain arsenious oxide present some special points of interest, since this oxide exhibits distinct basic and, in its salts, distinct acid properties. The general formulas for this class of compounds, so far as they have been studied, are

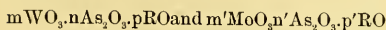

As characteristic salts we may take the arsenoso-molybdates



of which four have been obtained in fine crystals.

The copper and nickel salts of this type have a fine green color and, therefore, contain the two metals as ions, at least in part. It is, therefore, most probable that the salts are unitary. This view is supported by the fact that the alkaline salts from which the salts of manganese, copper, zinc and nickel are obtained by double decomposition give reactions which are different from those of the constituent molybdic and arsenious oxides. The same statement applies to other known arsenoso-molybdates and to arsenoso-tungstates.

I pass over without notice a number of interesting salts, some of which contain for a single determinant at least three different sub-determinants, as, for example, phosphoric and vanadic pentoxides and vanadic dioxide. We are only at the beginning of our knowledge of these compounds. From their extreme complexity it would seem most probable that they belong to the second class and are in some cases double, triple or quadruple salts, of which possibly the components may belong to the first class. Long and laborious investigations are required, sure to be rewarded by an abundant harvest of new facts, of little or no practical value perhaps, but to be looked at from the higher point of view of pure abstract knowledge.

The term 'complex inorganic' was at first intended to embrace all the compounds containing a relatively large number of molecules of tungstic and molybdic oxides as determinants, beginning with the silicotungstates of Marignac. Hittorf, in 1859, appears to have first drawn the distinction between double salts which are decomposed by solution and those which are stable under the same circumstances. Finally, Ostwald proposed to restrict the term 'complex' to the salts which are not decomposed by solution and which gave none of the chemical reactions of the constituents.

Of these two classes it is difficult to say

which is the more interesting and theoretically important. The salts of the first class are comparatively new to chemists, and, in spite of all which has been done, offer a very wide field for investigation. Those of the second class present new species of double and even of triple and quadruple salts. It will first be necessary to study the whole subject by physical as well as by the purely chemical methods which all chemists have hitherto employed, so as to define as distinctly as possible the limit, if there be one, which separates the two classes from each other. I make the point that all known methods of distinguishing double from unitary salts should be employed in each case, as I believe it has not yet been satisfactorily shown that all these methods give coincident results. It seems also possible that there may exist between the two classes given a third class, the salts belonging to which exhibit intermediate properties. In chemistry, as in other branches of science, sharply defined boundaries between groups are the exception. I am not aware that the chief methods of distinguishing between single and double salts have been brought together for reference, and perhaps the following list may be convenient:

1. Purely chemical or reaction tests.
2. Decomposition by solution alone.
3. Physical methods.
  - a. Determination of the electric conducting power of dilute solutions.
  - b. Determination of the ions by electrolysis and by spectroscopic observations.
  - c. Observation of the change of temperature in the formation of the complex salt. Heat is evolved in the formation of a complex salt from unitary molecules; none in the formation of a double salt. The formation of a complex salt, therefore, is accompanied by a loss of energy.

Other methods have been given, but the above mentioned will suffice for most purposes.

In the brief and elementary sketch which I have given to-day of two large and im-

portant classes of salts I have avoided the use of the so-called structural, or, as they should be termed, valence formulas. That such formulas are often useful, if only as checks upon purely speculative work, cannot be doubted. But it seems to me that the time has come for wider and more general conceptions of the chemical action between masses, subject perhaps to the fundamental idea of valence and yet not too dependent upon this idea as at present received. In a paper published long since, an attempt was made to extend the atomistic conception and to maintain the theory that the action of one complex mass upon another is determined by the residual unsaturated units of affinity present, without reference to the number of units due to each atomic mass. I venture now to suggest that, in addition to its valence, each atom and each molecule possesses a special chemical potential, not necessarily a function of its valence. The expression 'chemical potential' is not wholly new, but I think the conception has never been clearly defined. I would now define it as bearing the same relation to chemical action which the electric potential bears to electrical action, the two potentials being mutually convertible, all chemical compounds having residual affinities or potentials besides the valencies. If we suppose that the atoms within the molecule are in motion, such motion will be independent of the valences and the molecule will have a certain amount of free kinetic energy convertible into chemical electrical energy or into heat.

In inorganic chemistry four great problems now present themselves for solution. These are:

The existence and chemical relations of the gaseous elements, of which five are known to exist in the atmosphere. The separation of the elements forming the rare earths, by systematic processes and the determination of their positions in the periodic



series; the thorough and, so far as possible, exhaustive study of the complex and double salts and, finally, the determination of the atomic masses of the elements with all the precision of which the subject admits, and in the spirit of Stas, of Richards and of Morley.

WOLCOTT GIBBS.

A HALF-CENTURY OF EVOLUTION, WITH  
SPECIAL REFERENCE TO THE EFFECTS  
OF GEOLOGICAL CHANGES ON  
ANIMAL LIFE.\*

ONLY a little less than fifty years have passed since the publication of Darwin's Origin of Species, and the general acceptance by naturalists of the theory of descent. Since 1848 the sciences of embryology, cytology and comparative anatomy based on embryology, or, as it is now called, morphology, have been placed on a firm foundation. It is but little over half a century since the uniformitarian views of Lyell were promulgated. The cell doctrine was born in 1839; the view that protoplasm forms the basis of life was generally received forty years since; fifty years ago the doctrine of the conservation of forces was worked out, and already by this time had the idea of the unity of nature dominated the world of science.

On the fiftieth anniversary, therefore, of our Association, it may not be out of place, during the hour before us, first, briefly to inquire into the present state of evolution and its usefulness to zoologists as a working theory, and then to dwell more at length on the subject of the effect of geological changes on animal life.

The two leading problems which confront us as zoologists are: What is life? and How did living beings originate? We must leave to coming centuries the solution of the first question, if it can ever be

\*Address of the Vice-President before Section F.—Zoology—of the American Association for the Advancement of Science, August 22, 1898.

solved; but we can, as regards the second, congratulate ourselves that, thanks to Lamarck, Darwin and others, in our day and generation, a reasonable and generally accepted solution has been reached.

Time will not allow us to attempt to review the discoveries and opinions which have already been discussed by the founders and leaders of the different schools of evolutionary thought, and which have become the common property of biologists, and are rapidly permeating the world's literature.

It may be observed at the outset that, if there is any single feature which differentiates the second from the first half of this century, it is the general acceptance of the truth of epigenetic evolution as opposed to the preformation or incasement theory, which lingered on and survived until a late date in the first half of the present century.\*

\*The theory of incasement (*embolment*), propounded by Swammerdam in 1733, was that the form of the larva, pupa and imago of the insects pre-existed in the egg, and even in the ovary, and that the insects in these stages were distinct animals contained one inside the other, like a nest of boxes, or a series of envelopes one within the other; or, in his own words: "*Animal in animali, seu papilio intra cruceam reconditus.*" Réaumur (1734) also believed that the caterpillar contained the form of the chrysalis and butterfly, saying: "Les parties des papillon cachées sous le fourreau de chenille sont d'autant plus faciles à trouver que la transformation est plus proche. Elles y sont néanmoins de tout temps." He also believed in the simultaneous existence of two distinct beings in the insect. "Il serait très curieux de connaître toutes les communications intimes qui sont entre la chenille et le papillon. \* \* \* La chenille hache, broye, digere les aliments qu'elle distribue au papillon; comme les mères préparent ceux qui sont portés aux fœtus. Notre chenille en un mot est destinée à nourrir et à défendre le papillon qu'elle renferme." (Tome i, 8<sup>e</sup> Mémoire, p. 363.)

It was not until 1815 that Herold exploded this error, though Kirby and Spence in 1828, in their Introduction to Entomology, combated Herold's views and maintained that Swammerdam was right. As late as 1834, a century after Swammerdam, Lacordaire, in his Introduction à l'Entomologie, declared that 'a caterpillar is not a simple animal, but compound,' and he actually goes so far as to say that 'a

The establishment of the epigenetic view is largely due to exact investigation and modern methods of research, but more especially to the results of modern embryology and to the fairly well digested facts we now have relating to the development of one or more types of each class of the animal kingdom.

To use a current phrase, the evolution theory as now held has come to stay. It is the one indispensable instrument on which the biologist must rely in doing his work.

caterpillar, at first scarcely as large as a bit of thread, contains its own teguments threefold and even eightfold in number, besides the case of a chrysalis, and a complete butterfly, all lying one inside the other.' This view, however, we find is not original with Lacordaire, but was borrowed from Kirby and Spence without acknowledgment. These authors, in their *Introduction to Entomology* (1828), combated Herold's views and stoutly maintained the old opinions of Swammerdam. They based their opinions on the fact, then known, that certain parts of the imago occur in the caterpillar. On the other hand, Herold denied that the successive skins of the pupa and imago existed as germs, holding that they are formed successively from the '*rete mucosum*,' which we suppose to be the hypodermis of later authors. In a slight degree the Swammerdam, Kirby and Spence doctrine was correct, as the imago does arise from germs, *i. e.*, the imaginal disks of Weismann, while this was not discovered by Herold, though they do at the outset arise from the hypodermis, his *rete mucosum*. Thus there was a grain of truth in the Swammerdam, Kirby and Spence doctrine, and also a mixture of truth and error in the opinions of Herold.

The discovery by Weismann of the imaginal discs or buds of the imago in the maggot of the fly, and his theory of histolysis, or of the more or less complete destruction of the larval organs by a gradual process, and his observation of the process of building up of the body of the imago from the previously latent larval buds, was one of the triumphs of modern biology. It is, therefore, not a little strange to see him at the present day advocating a return to the preformation views of the last century in the matter of heredity. Of course, it goes without saying, as has always been recognized, that there is something in the constitution of one egg which predestines its becoming an insect, and in that of another which destines it to produce a chick.

It is now almost an axiomatic truth that evolution is the leaven which has leavened the whole lump of human intellectual activity. It is not too much to claim that evolutionary views, the study of origins, of the beginning of organic life, the genesis of mental phenomena, of social institutions, of the cultural stages of different peoples and of their art, philosophy and religion—that this method of natural science has transformed and illuminated the philosophy of the present half-century.\*

It is naturally a matter of satisfaction and pride to us as zoologists that, though evolution has been in the air from the days of the Greek philosophers down to the time of Lamarck, the modern views as to the origin of variations, of adaptation, of the struggle for existence, of competition, and the preservation of favored organs or species by selection, are the products of single-minded zoologists like Darwin, Wallace, Fritz Müller, Semper and Haeckel. It is

\* It is worthy of mention that just fifty years ago in his '*Future of Science*,' written in 1848, at the age of 25, Renan, who perhaps first among philosophers and students of comparative philology adopted the scientific method, *i. e.*, the patient investigation of as wide a range of facts as possible, wrote: "I am convinced that there is a science of the origins of mankind and that it will be constructed one day, not by abstract speculation, but by scientific researches. What human life in the actual condition of science would suffice to explore all the sides of this single problem? And still, how can it be resolved without the scientific study of the positive data? And if it be not resolved how can we say that we know man and mankind? He who would contribute to the solution of this problem, even by a very imperfect essay, would do more for philosophy than by half a century of metaphysical meditation" (p. 150). Again he says: "The great progress of modern thought has been the substitution of the category of *evolution* for the category of the '*being*;' of the conception of the relative for the conception of the absolute, of movement for immobility. Formerly everything was considered as '*being*' (an accomplished fact); people spoke of law, of religion, of politics, of poetry in an absolute fashion. At present everything is considered as in the process of formation" (p. 169).

the work of these men, supplemented by the labors of Spencer and of Huxley, and the powerful influence of the botanists Hooker and Gray, all of whom contributed their life-long toil and efforts in laying the foundation stones of the theory, which has brought about its general acceptance among thinking men. It is these naturalists, some of them happily still living, who have worked out the principle of evolution from the generalized to the specialized, from the simple to the complex, from chaos to cosmos.

The doctrine of evolution has been firmly established on a scientific basis by many workers in all departments of biology, and found not only to withstand criticism from every quarter, but to be an indispensable tool for the investigator. The strongest proof of its genuine value as a working theory is that it has, under the light shed by it, opened up many an avenue of inquiry leading into new fields of research. It is based on the inductive method, the observation and arrangement of a wide series of facts. Moreover, it explains a vast complex of facts, and enables us to make predictions, the true test of a scientific theory. Biology is not an exact science, hence the theory is not capable of demonstration like a problem in mathematics, but is based on probabilities, the circumstantial evidence being apparently convincing to every candid, well-trained mind.

The methods and results of natural science, based as they now are on evolutionary grounds, have, likewise, appealed to the historian, the philologist, the sociologist, and the student of comparative religion, whose labors begin with investigations into the origins.

It goes without saying that, thanks to the initiative of the above-named zoologists, every department of intellectual work and thought has been rejuvenated and rehabilitated by the employment of the modern scientific method. All inquiring minds ap-

preciate the fact that, throughout the whole realm of nature, inorganic, as well as organic, physical, mental, moral and spiritual, there was once a beginning, and that from a germ, by a gradual process of differentiation or specialization, the complex fabric of creation has, by the operation of natural laws and forces, been brought into being. All progress is dependent on this evolutionary principle, which involves variation, adaptation, the disuse or rejection of the unfit, the use or survival of the fittest, together with the mechanical principle of the utmost economy of material.

Though the human mind has its limitations, and the chief arguments for evolution have been drawn from our observations of the history of our own planet, and of the life existing upon it, the nebular hypothesis teaches us that the same process has determined the origin of other worlds than ours and applies in fact to all the other members of our solar system, while with little doubt the principles may be extended to the entire universe.

At all events, evolutionary methods of thinking have now become a second nature with philosophic, synthetic minds, and to such any other view is inconceivable. We teach evolution in our colleges and universities, and the time is rapidly approaching, and in some instances has already come, when nature studies, and the facts of biology forming the grounds of the evolutionary idea, will be taught in our primary and secondary schools.

The rapidity with which evolutionary conceptions have taken root and spread may be compared to the rankness of growth of a prepotent plant or animal on being introduced into a new territory where it is free from competition. It has, indeed, swept everything before it, occupying a field of thought which hitherto had been unworked by human intelligence.

The immediate effect, and a very happy



one, of the acceptance of the theory of descent on working zoologists is to broaden their minds. Collectors of insects and shells, or of birds and mammals, instead of being content simply to acquire specimens for their cabinets, are led to look during their field excursions for examples of protective mimicry, or to notice facts bearing on the immediate cause of variation. Instead of a single pair of specimens, it is now realized that hundreds and even thousands collected from stations and habitats wide apart are none too many for the study of variation as now pursued.

The race of 'species grinders' is diminishing, and the study of geographical distribution, based as it is on past geographical changes and extinctions, is now discussed in a far more philosophical way than in the past. The most special results of work in cytology and morphology are now affording material for broad work in phylogeny and heredity.

On the other hand, it must be confessed that, as the result of the acceptance of evolutionary views, our literature is at times flooded with more or less unsound hypotheses, some tedious verbiage and long-winded, aërial discussions, based rather on assumptions than on facts. But on the whole, perhaps, this is a healthy sign. Too free, exuberant growths will be in the long run lopped off by criticism.

One tendency should be avoided by younger students, that of too early specialization, and of empirical work without a broad survey of the whole field. In some cases our histologists and morphologists rise little above the intellectual level of species describers. Expert in the use of the microtome and of reagents, they appear to have but little more general scientific or literary culture than high-class mechanics. The chief antidote, however, to the danger of narrowness is the lessons derived from evolutionary thought and principles.

Finally, as a proof of the value of evolutionary ideas to the present generation, let us suppose for a moment, if it were conceivable, that they should be blotted out. The result, it is safe to say, would be equivalent to the loss of a sense.

It is a matter of history that when a new idea or principle, or a new movement in philosophy or religion, arises it at first develops along the line of least resistance; the leaders of the new thought acquire many followers or disciples. Soon the latter outstrip their teachers, and go to greater extremes; modifications of the original simple condition or theory occur, and as the final result there arise schisms and differentiations into new sects. This has happened in science, and already we have evolutionists divided into Lamarckians and Darwinians, with a further subdivision of them into Neolamarckians and Neodarwinians, while the latter are often denominated Weismannians. Some prefer to rely on the action of the primary factors of evolution; others believe that natural selection embraces all the necessary factors, while still others are thoroughly persuaded of its inadequacy.

The result of this analytical or differentiating process will probably be an ultimate synthesis, a belief that there is a complex of factors at work. Of these factors those originally indicated by Lamarck, with the supplementary ones of competition and natural selection bequeathed by Darwin, are the most essential and indispensable, and it is difficult to see how they can be displaced by other views. Meanwhile all agree, and it was never more firmly established than at this moment, that there is, and always has been, unceasing energy, movement and variation, a wonderful adaptation and harmony in nature, between living beings and their surroundings.

The present status of evolution in its different phases or attitudes since the time of



the appearance of Darwin's *Origin of Species* may be roughly pointed out as follows:

1. The claim by some thinkers of the inadequacy of Darwinism, as such, or Natural Selection, to account for the rise of new species, and the assignment of this factor to what they believe to be its proper place among the other factors of organic evolution.

2. The renaissance of Lamarckism under the name of Neolamarckism, being Lamarckism in its modern form. This school relies on the primary factors of evolution, on changes in the environment, such as the agency of the air, light, heat, cold, changes in climate, use and disuse, isolation, and parasitism, while it regards natural, sexual, physiological, germinal and organic selection, competition or its absence, and the inheritance of characters acquired during the lifetime of the individual, as secondary factors, calling into question the adequacy of natural selection as an initial factor.

3. The rise of the Neodarwinian school. While Darwin, soon after the publication of the *Origin of Species*, somewhat changed his views as to the adequacy of natural selection, and favored changes in the surroundings, food, etc., as causes of variation, his successors, Wallace, Weismann and others, believe in the 'all-sufficiency' of natural selection. Weismann also invokes panmixia, or the absence of natural selection, as an important factor; also amixia, and denies the principle of inheritance of acquired characters, or use-inheritance.

4. A third school or sect has arisen under the leadership of Weismann, who advocates what is in its essence apparently a revival of the exploded preformation, encasement or 'evolution' theory of Swammerdam, Bonnet and Haller, as opposed to the epigenetic evolutionism of Harvey, Wolff, Baer and the majority of modern embryologists. On the other hand, there are some embryologists who appear to ac-

cept the combined action of epigenesis and evolution in development.

5. Attention has been concentrated on the study of variations and of their cause. Opinion is divided as to whether variation is fortuitous or definite and determined. Many now take exception to the view, originally held by Darwin, that variations are purposeless and fortuitous, believing that they are, for example, dependent on changes in the environment which were determined in early geological periods. For definite variations Eimer proposes the term orthogenesis. Minute variations dependent on climatic and other obscure and not readily appreciable causes are now brought out clearly by a system of varied and careful quantitative measurements.

6. More attention than formerly is given to the study of dynamical evolution, or kinetogenesis; to the effect of external stimuli, such as intermittent pressure, mechanical stresses and tensions by the muscles, etc., on hard parts. Originally suggested by Herbert Spencer, that the ultimate cause or mechanical genesis of the segmentation of the vertebrate skeleton was due to transverse strains, the segmentation of the bodies of worms and arthropods, as well as of vertebrates, has been discussed by recent workers (Rider, Cope, Meyer, Tornier, Hirsch and others.) Here should be mentioned the work done in general physiology, or morphogenesis, by Verworn, Davenport and others. Also the discoveries of Pasteur, and the application by Metschnikoff and of Kowalevsky of phagocytosis to the destruction and renewal of tissues during metamorphosis, bear closely on evolutionary problems.

7. A new field of research, founded by Semper, Vilmorin and Plateau, and carried on by DeVarigny, is that of experimental evolution, involving the effects of artificial changes of the medium, including temperature, food, variation in the volume of water

and of air, absence of exercise, movement, etc. Also should be added horticultural experiments which have been practised for many years, as well as the results of acclimatization.

Here should be mentioned the experiments bearing on the mechanics of development (*Entwickelungsmechanik der Organismen*), or experimental embryology, of Oscar Hertwig, Roux, Driesch, Morgan and others, and the curious results of animal grafting and of mutilations of the embryos, obtained by Born and others, as well as the regeneration of parts. The remarkable facts of adaptation to new and unfavorable conditions of certain embryos are as yet unexplained, and have led to considerable discussion and research.

8. The *a priori* speculations of Darwin, Galton, Spencer, Jaeger, Nusbaum, Weismann and others, based on the results of the labors of morphologists and cytologists, have laid the foundation for a theory of the physical basis of heredity, and for the supposition that the chromatine in the nucleus of reproductive cells is the bearer of heredity. The theory has already led to prolonged discussion and opened up new lines of work in cytology and embryology.

9. The subject of instinct, discussed from an evolutionary point of view, both by morphologists and psychologists, particularly by Lloyd Morgan, has come to the front, while mental evolution has been discussed by Romanes and others.

With all these theories before us, these currents and counter-currents in evolutionary thought bearing us rapidly along, at times perhaps carrying us somewhat out of our depth, the conclusion of the whole matter is that in the present state of zoology it will be wise to suspend our judgment on many theoretical matters, to wait for more light and to confine our attention meanwhile to the observation and registration of facts, to careful experiments and to re-

peated tests of mere theoretical assumptions.

Meanwhile we may congratulate ourselves that we have been born and permitted to labor in this nineteenth century, the century which in zoological science has given us the best years of Lamarck's life, a Cuvier, a Darwin, a Von Baer, an Owen, an Agassiz, a Haeckel, a Spencer, and a Huxley—the founders of modern zoology—who have sketched out the grander features of our science so completely that it will, perhaps, be the work of many coming years to fill in the details.

#### GEOLOGICAL CAUSES OF VARIATION AND OF THE EXTINCTION AND RENEWAL OF SPECIES.

The most immediate and efficient cause of variation appears to be changes of environment or of the physical conditions of existence. These, besides the agencies of gravity, electricity, of the atmosphere, light, heat, cold, food, etc., comprise geological changes or revolutions in the topography of the earth's surface at different periods. The latter causes appear to have had much to do with the process of extinction and renewal of plants and animals.

While the doctrine of the effect on animals of a change of environment was suggested very early in this century and forms the corner stone of Lamarckism, Wallace was, after De la Beche,\* and especially Lyell†, the first in recent times, in an essay published in 1855, to call attention to this subject thus:

"To discover," he says, "how the extinct species have from time to time been replaced by new ones down to the very latest geological period, is the most difficult, and

\*Researches in Theoretical Geology. New York, 1837, p. 217. Quoted by Woodworth, p. 220.

† Principles of Geology, 1830-1832.

at the same time the most interesting, problem in the natural history of the earth."\*

Still more recently † he remarks:

"Whenever the physical or organic conditions change to however small an extent, some corresponding change will be produced in the flora and fauna, since, considering the severe struggle for existence and the complex relations of the various organisms, it is hardly possible that the change should not be beneficial to some species and hurtful to others."

Two conclusions are now generally accepted. The first is, that the most complete evidence of evolution is afforded by paleontology. Huxley's vigorous affirmation, that the primary and direct evidence in favor of evolution can be furnished only by paleontology, has been greatly strengthened by recent discoveries. The second is that biological evolution has been primarily dependent on physical and geological changes.

It may not be unprofitable for us as zoologists to pass in review some of the revolutions in geological history, particularly as regards our own continent, some important details of which have recently been worked out by our geologists, and to note the intimate relation between these revolutions and the origination not only of new species, but of new faunæ, and, indeed, at certain epochs, of new types of organic life.

1. *Precambrian revolutions.* That immensely long period which intervened between the time when our planet had cooled down and become fitted for the existence of animal life, and the opening of the Cambrian period, was evidently a time of the geologically rapid production of ordinal and class types of invertebrate life. This is strongly suggested by the fact that a large proportion of the Cambrian classes embrace forms as highly specialized as their successors of the present day, so that we are com-

pelled to look many ages back of the Cambrian for the appearance of their generalized ancestral forms.

Of the eight branches, of phyla, of the animal kingdom, the remains of seven, or all except the vertebrates, have been found in Cambrian strata. Adopting the kind of statistics employed by Professor H. S. Williams in his admirable *Geological Biology*, but with some changes necessitated by a little different view as to the number of classes living at the beginning of the Cambrian period, it appears that 13 out of 26 classes of the animal kingdom, occurring in a fossil condition, already existed in the Cambrian and, if we throw out from the vertebrate classes those without a solid skeleton (the Enteropneusta or Balanoglossus, Tunicates, Amphioxus and the lampreys) 13 out of 22. Also, if we exclude the land forms (Arachnida, Myriopoda and insects), 13 out of 19, and then throwing out the five vertebrate classes found in a fossil state, of 14 invertebrate marine classes 13 occur in the Cambrian.\* With little doubt flat-worms, nemerteans, Nematelminthes and Gephyrea existed then, and probably the representatives of other classes, of which no traces will ever occur.

We shall for our present purpose follow the classification of the U. S. Geological Survey and restrict what was formerly called the Archean to the fundamental gneiss and crystalline schists of an unknown thickness, and accept the Algonkian, as comprising the Huronian and Keeweenawan formations. We may assume that the first beginnings of life took place toward the end of the Archean and that the more or less rapid differentiation of class types went on during Algonkian time. This view is fortified by the statement of Wal-

\* Should the Polyzoa be traced to the Cambrian, as is not at all impossible, the fact would remain that every class of marine invertebrates with solid parts is represented in the Cambrian.

\* Natural Selection, p. 14.

† Darwinism, 1889, p. 115.



cott that a great orographic movement, followed by long-continued erosion, took place between the Archean and Algonkian ages.

Taking as an example of the nature of the Algonkian changes one region alone, the Lake Superior region, where the stratigraphical record is more complete, we have: 1, the Lower Huronian schists, limestone, quartzites, conglomerates, etc., with their eruptives, closely folded and attaining a maximum thickness of probably over 5,000 feet.

2. The Upper Huronian, unconformable to the Lower, a series of more gently folded schists, slates, quartzites, conglomerates, interbedded and cut by trap, with a maximum thickness of 12,000 feet. In the Animikie quartzites of this age have, according to Selwyn, been detected a track of organic origin, in the Minnesota quartzites *Lingula*-like forms, as well as obscure "trilobitic-looking impressions; while carbonaceous shales are abundant."

3. Between these Huronian rocks and the true Cambrian series are interpolated the Keweenaw clastic rocks, with a maximum thickness of 50,000 feet. Though these beds are by some high authorities referred to the Cambrian, the fact remains that this series, whether Cambrian or Algonkian, is unconformable to the Huronian, and composed of fragmental rocks, the upper division being 15,000 feet thick, and consisting wholly of detrital material largely derived from the volcanoes of the same series. Between each series is an unconformity representing an interval of time long enough for the land to have been raised above the sea, for the rocks to be folded, to have lost by erosion thousands of feet, and for the land to sink below the surface of the ocean.

Again, between the Precambrian and Cambrian there was, according to Walcott, a great uplift and folding of rock, succeeded by long-sustained erosion, over all the con-

tinental area. It was not, however, he states, 'as profound as the one preceding Algonkian time, as is proved by the more highly contorted and disturbed Archean rocks beneath the relatively less disturbed Algonkian series.'\*

The evidence of the existence of life-forms in the Huronian and Keweenaw times is indicated by the presence of thick beds of graphitic limestone, beds of iron carbonates, and by a great thickness of carbonaceous shales, which are represented by graphitic schists in the more altered strata. In the Animikie rocks on the northern shores of Lake Superior, Ingalls finds abundant carbon, and it is said that in certain mines and openings rock-gas forms to a considerable extent. Also small quantities of rock may even be obtained which will burn. "These substances must result from the ordinary processes which produce rock-gas and coal in the rocks of far later age. The hydrocarbons which occur so abundantly in the slightly metamorphosed shales of the Huronian about Lake Superior must be of organic origin," and, if so, the graphitic schists of the same system "are in all probability only those hydrocarbonaceous shales in a more altered condition."

As to the fossils actually detected in what are by some geologists regarded as Algonkian strata, Winchell has detected a *Lingula*-like shell in the pipestones of Minnesota. Selwyn has described traces of animals in the Upper Huronian of Lake Superior. Murray, Howley and Walcott have discovered several low types in the Huronian of Newfoundland; *i. e.*, a mollusc (*Aspidella terranovica*)† and traces of a worm (*Aren-*

\* The North American Continent during Cambrian Time. Twelfth Ann. Rep. U. S. Geological Survey, p. 544.

† Dr. G. F. Matthew writes me as follows regarding this supposed fossil: "I have seen *Aspidella terranovica* in the museum at Ottawa and doubt its organic origin. It seems to me a slickensided mud-



*icolites spiralis*), the latter said to occur in the primordial rocks of Sweden. Walcott reports the discovery, in the Grand Cañon of the Colorado, of the following Precambrian fossils: "A minute discinoid or patelloid shell, a small *Lingula*-like shell, a species of *Hyalolithus*, and a fragment of what appears to have been the pleural lobe of the segment of a trilobite belonging to a genus allied to the genus *Olenellus*, *Olenoides*, or *Paradoxides*. There is also an obscure *Stromatopora*-like form that may not be organic.

Here should be noted the discovery, in 1896, of *Radiolaria*\* in calcareous and cherty rocks of 'undoubted Precambrian age' near Adelaide, Australia (*Nature*, Dec. 24, 1896, p. 192); the detection of fossils in the Archean of Brittany, and of three veins of anthracite 'in crystalline schists of Archean age' in Ecuador.

At St. John, New Brunswick, that able and experienced geologist, Dr. G. F. Matthew, has detected fossils in strata which he refers to the upper Laurentian. They occur in three horizons. The lowest series is composed of a quartzite containing fragments of the skeleton of hexactinellid sponges allied to *Cyathospongia*. In the upper limestone of the second horizon were collected calcareous coral-like structures resembling *Stromatopora rugosa*. In the third and uppermost horizon, consisting of beds of graphite, occurred great numbers of spicules of apparently hexactinellid sponges. "Between this upper Laurentian system and the basal Cambrian occurs," says

concretion striated by pressure. I have found similar objects, in the Etcheminian olive gray beds below the St. John group."

\*Dr. Matthew likewise informs me: "The (*Radiolarian*?) rocks of Adelaide, South Australia, Mr. Howchin writes to me he now finds to be Lower Cambrian. He has found *Archeocyathus* in them; but this is not proof of *Lowest* Cambrian, as the genus is found in the *Paradoxides* beds of the south of France."

Matthew, "a third system, the Coldbrook and Coastal, Huronian, which has given conglomerates to the Cambrian and has a great thickness." He also tells us that the Precambrian St. Etcheminian beds at St. John, consisting of red and green slates and shales, have a meagre fauna comprising Protozoa, brachiopods, echinoderms, molluscs, with plentiful worm burrows and trails. In commenting on this subject Sir J. W. Dawson remarks that these Etcheminian strata rest on Huronian rocks which, near Hastings, Ontario, contain worm burrows, sponge-spicules, 'and laminated forms comparable to *Cryptozoon* and *Eozoon*.' (*Nature*, Oct. 15, 1896, p. 585.)

Even allowing room for error in the correlation of these formations, and in regarding some of these rocks as no older than Cambrian, yet on the whole the result appears to be that abundant vegetation existed in Precambrian times, which was converted into graphite, while representatives of seven classes were perhaps already in existence previous to the Cambrian period.

The following lists give a comparative view of the classes of the periods in question:

Precambrian Classes.	Cambrian Classes.
Rhizopoda ( <i>Radiolaria</i> ).	Rhizopoda ( <i>Foraminifera</i> and <i>Radiolaria</i> ).
Porifera ( <i>Hexactinellid Sponges</i> ).	Porifera ( <i>Sponges</i> ).
Actinozoa ( <i>Corals</i> ).	Hydrozoa ( <i>Meduse</i> and <i>Graptolites</i> ).
Brachiopoda.	Actinozoa ( <i>Corals</i> ).
Annelida.	Brachiopoda.
	Annelida.
	Crinoidea.
	Asteroidea.
	Lamellibranchiata.
Mollusca.	Gastropoda (including <i>Pteropoda</i> *).
	? Cephalopoda ( <i>Orthoceras</i> ?).
Trilobita.	Trilobita.
	Crustacea.

\*Dr. Matthew writes me that he doubts if *Hyalithoid* shells should be referred to *Pteropoda*. "Pel-seneer quite repudiates them; and to me their heavy shells, and frequent habitat on rough shores, do not speak of the fragile *Pteropoda*."

It would seem from these data that the physical condition of the sea and atmosphere was favorable to the existence of types for aught we know quite or nearly as highly specialized as those of the same classes now in existence. Life and nature in the Precambrian went on, so far as we can tell, much as in Cambrian times. Though locally there are breaks in the continuity of geological processes, yet probably over the world generally there was a continuity of geological phenomena, and on the whole a tolerably unbroken series of organic forms.

It is obvious, however, that in the regions thus far examined, the Precambrian, whether we include the Archean or not, more than at any time since, though the land areas are by some considered to be of small extent, was a period of widespread and profound changes in the distribution of land and sea. While it is generally supposed that the extent of the continental areas at the beginning of Paleozoic time was small, forming islands, Walcott is inclined to the belief that it was very considerable, stating:

“The continent was larger at the beginning of the Cambrian period than during any epoch of Paleozoic time, and probably not until the development of the great fresh-water lakes of the Lower Mesozoic was there such a broad expanse of land between the continental platform between the Atlantic and Pacific Oceans. The agencies of erosion were wearing away the surface of this Algonkian continent and its outlying mountain barriers to the eastward and westward, when the epoch of the Lower Cambrian or Olenellus zone began. The continent was not then new. On the contrary, it was approaching the base level of erosion over large portions of its surface. The present Appalachian system of mountains was outlined by a high and broad range, or system of ranges, that extended from the present site of Alabama to Canada,

and subparallel ranges formed the margins of basins and straits to the east and north-east of the northern Paleo-Appalachian or the Paleo-Green Mountains, and their northern extension toward the Precambrian shore-line of Labrador. The Paleo-Adirondacks joined the main portion of the continent, and the strait between them and the Paleo-Green Mountains opened to the north into the Paleo-St. Lawrence Gulf, and to the south extended far along the western side of the mountains and the eastern margin of the continental mass to the sea that carried the fauna of the Olenellus epoch around to the Paleo-Rocky Mountain trough.” (*l. c.* p. 562.)

Remarking on the habitat, or nature and extent of the sea-bottom tenanted by the Olenellus or Lower Cambrian fauna, Walcott remarks:

“One of the most important conclusions is that the fauna lived on the eastern and western shores of a continent that, in its general configuration, rudely outlines the North American continent of to-day. Strictly speaking the fauna did not live upon the outer shore facing the ocean, but on the shores of interior seas, straits, or lagoons that occupied the intervals between the several ridges that rose from the continental platform east and west of the main continental land surface of the time.” (*l. c.* p. 556.)

Dana had previously (1890) claimed that the earth's features even to many minor details were defined in Archean time (evidently referring to all Precambrian time) and that ‘Archean conditions exercised a special and even detailed control over future continental growth.’ May not this idea be extended to include the life of the Precambrian, and may we not suppose that biological variations and evolutions were predetermined to some degree at least by the geological conditions of these primeval ages? The continental masses were then

foreshadowed by submarine plateaus covered by shallow seas, the deeper portions of the ocean basins not being affected by these oscillations, extensive as they were.

The time which elapsed between the end of the Laurentian and the beginning of the Cambrian was immense, or at least as long as the entire Paleozoic era. Walcott estimates the length of the Algonkian at 17,500,000 years. This length of time, or even a portion of it, was long enough for the origination and establishment of those classes, whose highly specialized descendants flourished in the Cambrian. Referring to the Precambrian strata Walcott states :

"That the life in the pre-Olenellus seas was large and varied there can be little, if any, doubt. The few traces known of it prove little of its character, but they prove that life existed in a period far preceding Lower Cambrian time, and they foster the hope that it is only a question of search and favorable conditions to discover it."\*

Here the imagination of the zoologist may be allowed for the moment free scope to act. It is perhaps not hazardous to surmise that in the early centuries or millenniums of the Huronian there arose, from some aggregated or compound infusorian, the prototype of the sponges.

From some primitive gastrula which became fixed to the Huronian sea-bottom may have arisen the hydroid ancestor of the Cœlenterates; owing to its fixed mode of life, the primitive digestive cavity opened upwards, being held in place by the septa, so that the vase-shaped body, growing like a plant, with the light striking upon it from all sides, assumed a radical symmetry. Before the beginning of the Cambrian, for we know Aurelia-like forms abounded on the Cambrian coasts, medusæ budded out from some hydroid polyps, became free-swim-

ming, and as a result of their living at the surface became transparent, and thus shielded from the observation of whatever enemies they had, multiplied in great numbers.

From some reptant gastræa there may have sprung, in these primeval times, an initial form with a fore-and-aft, dorso-ventral and bilateral symmetry, which gave origin by divergent lines of specialization to flat-worms, nemertean and round-worms, as well as Rotifera, and other forms included among the Vermes. It is probable that the Trematodes and Cestodes, especially the latter, whose organs have undergone such reduction by parasitism, and some of which through disuse have totally disappeared, did not evolve until some time after the appearance of molluscs and fishes.

When existence in these early plastic vermian forms was confined to boring in the mud and silt, the body became cylindrical, as in some nemerteans, and in the thread-worms; some of the latter forms, boring into the mud, became parasites, entering the bodies of other animals which serve as their hosts.

At about this time certain worms, as the simple mechanical result perhaps of threading their way over or through the rough gravelly bottom, became segmented. The establishment of a segmental structure, brought about by the serpentine mode of progression in the direction of least resistance, resulted in the origination of a succession of levers. Following this annulated division of the dermo-muscular tube of worms, was the serial or segmental arrangement of the internal organs, *i. e.*, the nervous, excretory, reproductive and glandular, and, in a less degree, the circulatory.

In certain of these primitive protannelids, as the result perhaps of external stimuli intermittently applied, bristles originated to aid in progression, and finally the segmentally arranged lateral flaps of the

\* The fauna of the Lower Cambrian or Olenellus zone. Tenth Annual Report of the U. S. Geological Survey, 1888-89.

skin, the parapodia, which served as swimming organs. Other nepionic forms, at first free swimming, became fixed and protected by two valves as in the Brachiopoda, which owe their success in Precambrian times to their fixed and protected bodies.

Not long after the annelid type became established that of the echinoderms apparently diverged from some nepionic worm, like a trochosphere. In such a form there was a tendency to the deposition of particles and plates of lime in the walls of the body, and the type, becoming fixed at the bottom, or at least nearly stationary, and meanwhile more or less protected by a calcareous armor, lost its originally bilateral and acquired a radial symmetry.

But no echinoderms have yet been detected in Precambrian rocks, which, however, have revealed arthropods, as shown by the traces of trilobites, and this tends to indicate that radial symmetry is an acquired, not a primitive characteristic.

At this time was solved the problem of the origination of a type of body, and of supports for it either in walking or in swimming, which should fulfill the most varied conditions of life, and this type, the arthropodan, as events proved, was that fitted for walking over the sea-bottom, for swimming or for terrestrial locomotion; nor was the idea of segmentation both in trunk and limbs discarded when the type culminated in flying forms—the insects.

The Arthropoda, as the record shows, first represented by trilobites, which structurally are nearer the annelids than Crustacea, was destined to far outnumber in individuals, species, orders and classes any other phylum. Fundamentally worm-like or annelid in structure, the body consisted of a linear series of stiff levers, and was supported by limbs segmented in the same way. The variations of the arthropodan theme are greater than in any other groups, and nature, so to speak, succeeded most ad-

mirably in this type, with the exception of the Trilobita, which was the first class of the phylum to appear and the first to disappear. The evolution of jointed limbs was accomplished in the most economical and direct way. The parapodia were perhaps utilized, and at first retaining their form in swimming phyllopods, afterwards from being used as supports, became cylindrical and jointed. All this modification of monotypic forms and evolution from them to other types was accomplished not very late perhaps in the Precambrian. After the specialization of the antennæ and of the trunk-segments of the trilobites was worked out, all the postantennal appendages being alike, there ensued in some descendant of another vermician ancestor a further differentiation of the postantennal appendages into mandibles, maxillæ, maxillipedes, thoracic ambulatory legs, and abdominal swimming feet, as worked out in the more specialized members of the class of Crustacea.

As soon as the crustacean type became established, the conditions must have been most favorable for its rapid differentiation along quite divergent lines, for in the Cambrian strata occur the remains of four orders, viz., the Cirrhipedia, Ostracoda, Phyllopoda, the sole Cambrian form (*Protocaris marshi* related to the modern *Apus*), and the Phyllocarida. Of these the barnacles and ostracodes, with their multivalve or bivalve carapaces, are the most specialized, and in the case of the former the process of modification due to this fixed mode of life must have required ages, as must also the development of that highly modified vermician type, the Brachiopoda.

Indeed, the three lines of descent which resulted in the arthropodan phylum, as it now exists, unless there were three independent phyla, were perhaps initiated before the Cambrian. These lines are (1) the Trilobita, with their probable successors the merostomes and arachnids, (2) the



Crustacea, and (3) the myriopods and insects. Of the third line *Peripatus* or a *Peripatus*-like form was the earliest ancestor, which, of course, must have been terrestrial in habits, though its forebears may have been some fresh-water leech-like worm. We venture to state it is not wholly impossible that so composite a type as *Peripatus*, which bears at least some of the marks of being a persistent type, took its rise on the continental land of the Precambrian.

In the Precambrian time was also solved the problem by the molluscs of producing a spiral univalve shell; for while a large proportion of the Gastropoda were protected by patella-like shells of simple conical form, with these coexisted in the lowest Cambrian forms with spiral shells, such as *Platyceras* and *Pleurotomaria*. The comparative abundance of those highly modified molluscs, the Pteropoda, in the lowest or *Olenellus* Cambrian strata, strongly suggests that their divergence from the more generalized gastropod stem and their adaptation to a surface or pelagic life must have taken place long anterior to the dawn of the Cambrian.\*

With them must have lived a variety of other surface forms besides Rhizopoda, whose young served as their food. The members of all classes of the Cambrian were carnivorous, feeding on the protoplasm of the bodies of microscopic animals or on the eggs and young of their own species, some living on the bottom, and others at the surface. Of marine plants of the Cambrian there are but slight traces, and it is evident that what there were were restricted to the coasts and to shallow water. The old idea that plants originally

served as the basis of animal life must be discarded. As at present no plant life exists below a few fathoms, a hundred perhaps at the most, and since below these limits the ocean depths are packed with animal life which exists entirely on the young or the adults of weaker forms, so must the rise and progress of animal life have been quite independent of that of plants. The lowest plants and animals may have evolved from some common bit of protoplasm, some protist, but the evolution of the animal types became very soon vastly more complex. The specialization of parts and adaptation to the environment were more thorough and rapid in the lowest animals evidently in consequence of the greater power of locomotion, and aggressiveness in obtaining food from living organisms, and the adaptability of animal life to various oceanic conditions, especially temperature, bathymetrical conditions and a varying sea-bottom.

This rapid differentiation and multiplication of different family, ordinal and class ancestral types went on without those biological checks which operated in later times, when the seas and land masses of the globe became more crowded. There was a comparative absence of competition and selection, this being due to the lack of predaceous carnivorous forms to produce that balance in nature which afterwards existed. The two most successful and abundant types were the trilobites and brachiopods; but the former were not especially aggressive in their habits, undoubtedly taking their food in a haphazard way by burrowing in the mud or sand, having much the same kind of appendages and the same feeding habits as *Limulus*. The brachiopods were fixed or burrowed in the sand, straining the microscopic organisms drawn into the mouth by the currents set up through the action of their ciliated arms. The most destructive and aggressive Cam-

\* Dr. Matthew has discovered at St. John, N. B., a still lower and older bed, containing no *Olenellus*; but Foraminifera (*Orbulina* and *Globigerina*), sponges, Pteropoda, *Pelagiella* which was probably an oceanic Heteropod, very primitive brachiopods, with *Ostracoda* and six genera of trilobites.

brian animal known to us was the Orthoceratites, but its remains have not yet been detected below the 2d Cambrian zone. Even if some protocordate *Balanoglossus*, *Ascidians* or even *Amphioxus* had already begun their existence in these Precambrian times they could have caused but a little more destruction of life than their contemporaneous invertebrate allies. As the remains of *Ostracodermi* and sharks have been detected in Trenton strata, perhaps they originated in the Cambrian, when they must have been active forces in the elimination of those Precambrian soft-bodied animals which connected classes now quite wide apart.

The rapid increase in the Precambrian population was hastened by the probable fact that this, more than any subsequent period, was one of rapid migration and colonization. Vast areas of the shallow depths over the site of the embryo continent, more or less shut off from the main ocean by shoals, reefs and islands, were, by oscillations of the sea-bottom and land, opened up at various times to migrants from the older previously settled seas.

The nature of the Precambrian sediments shows that the more open sea-bottom was swept by tidal and ocean currents varying in strength and extent. The topography of the ocean bottom over what is now land must have been more diversified than at present. In the late ages of the Algonkian, owing to active competition and the struggle for existence in the overstocked areas, the process of segregation or geographical isolation was rapidly effected, and the migrants from the denser centers of growth pressed into the then uninhabited areas where, as new, vigorous and prepotent colonists, they broke ground and founded new dynasties.

At such times as these we can easily imagine that, besides the absence of competition, the Lamarckian factors of change

of surroundings bringing about new habits and thus inducing new needs, the use and disuse of organs, together with the inheritance of characters acquired during the lifetime of the individual, operated then far more rapidly and in a much more thoroughgoing way than at any period since, while all through this critical, creative period, as soon as there was a sufficient diversity in the incipient forms and structures, a selective principle began to operate.

For forty years past, since the time of Darwin, the idea that these early forms were more rapidly evolved, and that they were more plastic than forms now existing, has constantly cropped out in the writings of our more thoughtful and studious paleontologists and biologists.

Darwin, in his *Origin of Species*, as quoted by Walcott with approval, remarked that it is indisputable that, before the lowest Cambrian stratum was deposited, long periods elapsed, as long as, or probably far longer than, the whole interval from the Cambrian age to the present day; and that 'during these vast periods the world swarmed with living creatures.' Darwin then adds: "It is, however, probable, as Sir William Thompson insists, that the world at a very early period was subjected to more rapid and violent changes in its physical conditions than those now occurring; and such changes would have tended to induce changes at a corresponding rate in the organism which then existed."

Professor Hyatt,\* from his exhaustive studies on the *Nautiloidea* and *Ammonoidea*, concludes:

"These groups originated suddenly and spread out with great rapidity, and in some cases, as in the *Arietidæ* of the Lower Lias, are traceable to an origin in one well-defined species, which occurs in close proximity to the whole group in the lowest bed of the

\*Phylogeny of an Acquired Characteristic. Proc. Amer. Phil. Soc., XXXII, p. 371.

same formation. These facts, and the acknowledged sudden appearance of large numbers of all the distinct types of invertebrates in the Paleozoic, and of all the greater number of all existing and fossil types before the expiration of Paleozoic time, speak strongly for the quicker evolution of forms in the Paleozoic, and indicate a general law of evolution. This, we think, can be formulated as follows: *Types are evolved more quickly and exhibit greater structural differences between genetic groups of the same stock while still near the point of origin than they do subsequently. The variations or differences may take place quickly in the fundamental structural characteristics, and even the embryo may become different when in the earliest period, but subsequently only more superficial structures become subject to great variations.\**

If this applies to the evolution of these cephalopods in the Mesozoic, how much more rapidly and efficaciously did the principle operate in the Precambrian period, after the initial steps in the divergence of types from the unicellular Protozoon took place? The same law or fact obtains with the insects, the eight holometabolous orders having, so far as the evidence goes, originated at nearly the same geological date, near or soon after the close of the Paleozoic era. Williams also shows, from a study of the variations of *Atrypa reticularis*, that this species in its specific characters shows a greater degree of variability of plasticity in the earlier than in the later stages of its history. We thus conclude that after the simplest protoplasmic organisms originated, the greatest difficulties in organic development, *i. e.*, the origination of the founders of the different classes were, so to speak, met and overcome in Precambrian times. The period was one of the rapid evolution of types. As Williams† has well remarked :

\*Geological Biology, p. 322.

†L. c. p. 347.

"The chief expansion of any type of organism takes place at a relatively early period in its life history. Since then, as with the evolution of the continent itself, the further progressive differentiation of marine invertebrate forms has, since the close of the Precambrian, been a matter of detail."

As well stated by Brooks, since the first establishment of the Cambrian bottom fauna, "evolution has resulted in the elaboration and divergent specialization of the types of structure which were already established, rather than in the production of new types."

In accepting the general truth of this statement, and its application to the marine or Cambrian types it may, however, be modified to some extent. For during the late Paleozoic was witnessed the evolution of the three tracheate, land-inhabiting, air-breathing classes of Arachnida, Myriopoda and insects, and of the air-breathing vertebrates, with limbs and lungs, comprising the four classes of amphibians, reptiles, birds and mammals.

ALPHEUS S. PACKARD.

(To be concluded).

#### BOTANICAL NOTES.

##### ASPARAGUS RUST.

DR. B. D. HALSTED, of the New Jersey Experiment Station, has issued a bulletin No. 129) on the Asparagus Rust, its treatment and natural enemies, which is of much botanical interest, since it gives good illustrations of all the stages in natural size, and under different magnifications. This rust was described by De Candolle in 1805, and given the name which it now bears, *Puccinia asparagi*. It has been known in Europe for a long time, but was unknown in the United States before 1896. In that year Dr. Halsted detected it in New Jersey, Delaware, Long Island and some portions of New England. In 1897 and 1898 it has

spread southward and westward, but appears to be absent from the Mississippi Valley.

This bulletin is largely concerned with a discussion of the results of spraying with various fungicides. The conclusion is that spring spraying is of little if any practical value, since the reduction in the amount of rust is not proportionate to the cost of the work. Experiments are now in progress to determine whether autumn treatment by spraying or burning will be of any avail. Two natural enemies, both parasitic fungi, *Darluca filum* and *Tubercularia persicina*, have been observed the past year, 'both of which may be expected to assist materially in the checking of the ravages of the asparagus rust.'

#### POISONOUS PLANTS.

THE Division of Botany of the United States Department of Agriculture has issued a bulletin (No. 20), by V. K. Chesnut, upon the principal poisonous plants of the United States, which should be of the utmost use to all who have to deal with plants, from botanists and collectors to hunters and farmers. Only the plants to which attention has been particularly called are included, and it is not to be supposed that the list includes every poisonous species. Good illustrations are freely used, and in all cases general descriptions, popular names, habitat and discussions of the poisonous properties serve to render the account of the greatest value. The plants noticed are the following:

Family Agaricaceae: *Agaricus muscaria*, Fly amanita; *Agaricus phalloides*, Death Cup.

Family Melanthaceae: *Veratrum viride*, American false Hellebore.

Family Convallariaceae: *Convallaria majalis*, Lily-of-the-Valley.

Family Orchidaceae: *Cypripedium reginae*, Showy lady's slipper; *Cypripedium hirsutum*,

Larger yellow lady's slipper; *Cypripedium parviflorum*, Smaller yellow lady's slipper.

Family Alsinaceae: *Agrostemma githago*, Corn cockle.

Family Ranunculaceae: *Aconitum columbianum*, Aconite; *Delphinium tricorne*, Dwarf larkspur; *Delphinium geyeri*, Larkspur; *Delphinium menziesii*, Larkspur; *Delphinium recurvatum*, Larkspur; *Delphinium troiliiifolium*, Larkspur.

Family Prunaceae: *Prunus serotina*, Black cherry.

Family Cæsalpiniaceae: *Gymnocladus dioica*, Kentucky coffee tree.

Family Papilionaceae: *Astragalus mollissimus*, Woolly loco weed; *Astragalus lambertii*, Stemless loco weed; *Crotalaria sagittalis*, Rattlebox.

Family Euphorbiaceae: *Euphorbia lathyris*, Caper spurge; *Euphorbia marginata*, Snow on the mountain.

Family Anacardiaceae: *Rhus radicans*, Poison ivy; *Rhus diversiloba*, Poison oak; *Rhus vernix*, Poison sumac.

Family Sapindaceae: *Aesculus pavia*, Red buckeye.

Family Apiaceae: *Cicuta maculata*, Water hemlock; *Cicuta vagans*, Oregon water hemlock; *Conium maculatum*, Poison hemlock.

Family Ericaceae: *Kalmia latifolia*, Broad-leaf laurel; *Kalmia angustifolia*, Narrow-leaf laurel; *Rhododendron maximum*, Great laurel; *Pieris mariana*, Stagger bush; *Leucothœe catesbaei*, Branch ivy.

Family Loganiaceae: *Gelsemium semper-virens*, False jessamine.

Family Solanaceae: *Datura stramonium*, Jimson weed; *Datura tatula*, Jimson weed; *Solanum nigrum*, Black nightshade; *Solanum dulcamara*, Bittersweet; *Solanum triflorum*, Spreading nightshade.

Family Carduaceae: *Helenium autumnale*, Sneezeweed.

#### EDIBLE AND POISONOUS FUNGI.

ANOTHER bulletin (No. 15) from the Di-



vision of Vegetable Physiology and Pathology of the United States Department of Agriculture which will attract more than usual attention is that on 'Some Edible and Poisonous Fungi,' by Dr. W. G. Farlow, of Harvard University. In the introduction the author says: "The question which everyone asks first is: How can you tell a mushroom from a toadstool? This is one of the questions which no one can answer, unless an explanation of why the question should never be asked may be considered an answer. You cannot tell a mushroom from a toadstool, because mushrooms are toadstools. The reason why the question is so frequently asked is because the belief is well-nigh universal in this country that the fleshy umbrella-shaped fungi are divided into two classes, mushrooms, which are edible, and toadstools, which are poisonous. This assumed difference does not in fact exist. All the fleshy umbrella shaped fungi are toadstools, and to a small number of the best-known edible forms the name mushroom is applied popularly and in commerce; but not a small number of the other toadstools are edible, and a great many of them, probably the most of them, are not poisonous."

As to how we may tell an edible from a poisonous fungus, the author says: "Our knowledge on this point is empirical. We know that certain species are edible, and others are poisonous, because people have eaten the former and found them to be good, while the latter have produced unpleasant symptoms and even death." He says further that "with regard to the species which have not been tried experimentally or accidentally we can only say that they are probably edible or poisonous, judging by their resemblance to other species known to be such. Although, in the absence of experience, analogy is the only guide, it is not a sure guide, and unpleasant surprises may arise."

The sections which follow treat of growth, structure and characteristics of toadstools, followed by descriptions and figures of *Agaricus campestris*, the common mushroom, (edible); *Amanita muscaria*, the fly Agaric (poisonous); *Amanita phalloides*, the deadly Agaric (poisonous); *Agaricus arvensis*, the horse mushroom (edible); *Hypoloma appendiculatum* (edible); *Coprinus comatus*, the horsetail fungus (edible); *Lepiota procera*, parasol fungus (edible); *Cantharellus cibarius*, chanterelle (edible); *Marasmius oreades*, fairy-ring fungus (edible); tube-bearing fungi, morels, puff-balls, etc. A half dozen rules for the use of beginners close this valuable paper. It should be in the hands of every teacher of botany, from colleges and universities down through the high schools into the grammar and primary grades.

CHARLES E. BESSEY.

THE UNIVERSITY OF NEBRASKA.

#### CURRENT NOTES ON METEOROLOGY.

REPORT OF THE CHIEF OF THE WEATHER BUREAU.

FROM the *Report of the Chief of the Weather Bureau for 1896-97* we learn that during the last fiscal year a total of 4,625,250 weather maps was issued, and that daily forecasts and warnings were sent to 51,694 places, by mail, telegraph, telephone, etc. There are now 81 map-printing stations outside of Washington, D. C.; about 8,000 places from which climate and crop conditions are reported, and about 3,000 voluntary observers make daily observations. The stations at which storm signals are displayed number 253. The river and rainfall stations, making daily observations to be used in river and flood forecasts, number 113 and 42 respectively. Substantial progress has been made in perfecting the kites used in the exploration of the free air, and it is hoped soon to publish daily weather charts based on the high-level readings made by means of in-

struments sent aloft on kite lines. This would be a step in advance, of the very greatest practical value in forecasting. The discussion of the data obtained by the Weather Bureau during the International Cloud Year is in the hands of Professor F. H. Bigelow, and his report is to be ready during the present year. That our Weather Bureau is carrying on a very important work, of immense value to the commercial and agricultural interests of this country, is emphatically proved by a glance at this Report. It is to be hoped that the Chief of the Weather Bureau may secure the additional appropriations which he needs in order to carry on and to extend the work under his direction.

In addition to the usual tables of meteorological data, the Report contains two monographs, *Rainfall of the United States*, by A. J. Henry, and *Floods of the Mississippi River*, by Park Morrill, already published as separate Bulletins by the Bureau.

#### THE MAURITIUS OBSERVATORY.

THE *Annual Report* of the Director of the Royal Alfred Observatory for the year 1896 brings official announcement of the resignation of Dr. Meldrum from the directorship of that Observatory, a position which he had held for 22 years. The work which Dr. Meldrum has done in connection with the law of storms is well known wherever meteorology is studied the world over, and meteorologists will always associate his name with that of the island in the Indian Ocean on which he lived so long and worked so indefatigably. The new Director is Mr. T. F. Claxton, F.R.A.S., whose name appears on the new volume of *Results of the Magnetical and Meteorological Observations made at the Royal Alfred Observatory, Mauritius, in the Year 1896*. This publication contains the daily, monthly and annual values of the principal meteorological ele-

ments, and the usual tables of magnetical observations.

#### WEST INDIAN HURRICANES.

THE Weather Bureau has recently published an important article on West Indian hurricanes by the late Father Benito Viñes, formerly Director of the Colegio de Belen, Habana. Viñes' previous monograph entitled *Apuntes relativos a los huracanes de las Antillas en Setiembre y Octubre de 1875 y 1876* is a classic. The present article was prepared by Father Viñes, shortly before his death, for the Chicago Meteorological Congress of 1893, and has been translated from the Spanish by Dr. C. Finley, of Habana, the author revising the greater part of it before his death. The title is *Investigation of the Cyclonic Circulation and the Translatory Movement of the West Indian Hurricanes*. Owing to the present interest in everything that concerns the meteorological conditions of the West Indies, the Chief of the Weather Bureau has wisely decided to give this article immediate publication, rather than to await its long-delayed appearance in the Bulletin (No. 11) which contains the papers prepared for the Chicago Congress, three parts of which have been issued, leaving the fourth still to come.

R. DE C. WARD.

HARVARD UNIVERSITY.

#### CURRENT NOTES ON ANTHROPOLOGY.

##### PYGMY TRIBE IN AMERICA.

So far as I am aware, no tribe of dwarf stature has been found in America. The Changos, of the Atacama desert, are probably the shortest. The average of the males is four feet nine inches. Of course, individual instances of dwarfs occur in many tribes, as they do among ourselves. These are due to other laws of growth than a generally diminished height.

In the *Revue* of the Paris School of Anthropology for July, Dr. Collineau

quotes a Mr. Sullivan, from our country apparently, who describes a tribe in Venezuela, on the Brazilian frontier, the males of which average four feet eight inches. The reference is too vague to admit of verification, and if some reader of SCIENCE can give further information about the statement it will be welcome to anthropologists.

#### THE TURANIANS AGAIN.

A FEW years ago, in European ethnography, the Mongolians reigned paramount. As Friedrich Müller said, 'Mongolian' or 'Turanian' was a sack into which all nations were thrust who could not be assigned elsewhere. Basques, Etruscans, Pelasgians, Ligurians, all were Mongolian.

For some time past there has been a lull in this mania; but in the July number of the *Revue de l'École d'Anthropologie*, Professor Herné brings forward a hypothesis surpassing in eccentricity even those previously advanced in this direction. He makes all the Celts, 'no matter in what region they may be studied,' of direct Mongolian descent. They entered Europe in the neolithic period, and brought with them a culture and a type of their own, their affinities being to-day markedly Turanian or Ural-Altaic. Surely this theory is a few years late.

#### THE INFLUENCE OF CITIES IN MODERN LIFE.

In one of his thoughtful studies published in the *Correspondant* (May, 1898) the Marquis de Nadaillac discusses the concentration of the population into cities, so marked in our day. Its chief cause is undoubtedly that more money can be made and more amusement obtained in cities than in the country.

In cities the mortality is greater, the natality less, than in the country. Marriage is not so common, illegitimate unions more frequent. Mental alienation increases; suicides are more numerous. Criminality as a whole is decidedly higher.

What is the remedy? asks the collector of the ominous facts. His reply is, unceasing effort to teach men that 'life has an aim nobler than gain, higher than material enjoyment.' All will agree with the conclusion.

D. G. BRINTON.

UNIVERSITY OF PENNSYLVANIA.

#### SCIENTIFIC NOTES AND NEWS.

HONORARY DEGREES CONFERRED BY THE UNIVERSITY OF EDINBURGH.

WE recorded the telegraphic despatch stating that the University of Edinburgh had conferred the honorary degree of LL.D. on Professor H. P. Bowditch and Professor William Osler. The University at its medical graduation ceremony conferred the degree on nineteen persons, all of whom but two were in attendance on the meeting of the Medical Association. The complete list is as follows: Henry Pickering Bowditch, M.D., member of the National Academy of Sciences, United States of America, Professor of Physiology, Harvard University; Sir William Broadbent, M.D., F.R.S.; Thomas Lauder Brunton, M.D., D.Sc., F.R.S., Lecturer on *Materia Medica*, St. Bartholomew's Hospital School, London; Eugene Louis Doyen, M.D., Paris; David Ferrier, M.D., LL.D., F.R.S., Professor of Neuro-pathology, King's College, London; Joseph Forster, M.D., Professor of Hygiene and Bacteriology, University of Strassburg; M. le Comte de Franqueville, Officer of the Legion of Honor, member of the Institute of France; Carl Gerhardt, M.D., Professor of Medicine, University of Berlin; Richard Burdon Haldane, Q.C., M.P., Jonathan Hutchinson, M.D., LL.D., F.R.S., Emeritus-Professor of Surgery, London Hospital College; Theodor Kocher, M.D., Professor of Surgery, University of Berne; August Martin, M.D., Professor of Gynecology, University of Berlin; Johann Miculicz, M.D., Professor of Surgery, University of Breslau; Ottavio Morisani, M.D., Professor of Midwifery, University of Naples; William Osler, M.D., LL.D., Professor of Medicine, Johns Hopkins University, Baltimore; William Playfair, M.D., LL.D., Professor of Obstetric Medicine, King's College, London; Thomas



George Roddick, M.D., Professor of Surgery, McGill University, Montreal, president of British Medical Association, 1897; Siegmund Rosenstein, M.D., Professor of Clinical Medicine, University of Leiden; Herman Snellen, M.D., Professor of Ophthalmology, University of Utrecht; and Sir Richard Thorne, K.C.B., F.R.S., Principal Medical Officer, Local Government Board, London. In introducing Professor Bowditch, the Dean of the Faculty of Law said: "The metropolitan University of Scotland rejoices to offer her degree to one who is justly regarded as a pioneer and leader of scientific enterprise in the United States of America. The researches which the distinguished tenant of the chair of physiology in Harvard University has himself prosecuted have added not a little to the advancement of that science, notably those into the laws regulating the growth of children, the force of ciliary motion and the innervation of the vascular system. But, more than this, he has stimulated others to carry on research, and has so efficiently trained his countrymen in the most approved methods, that we are justified in largely attributing to his influence the present position of the American school of physiologists. I now beg you to confer upon the distinguished American the Honorary Degree of Doctor of Laws."

#### GENERAL.

THE American Association for the Advancement of Science has begun the celebration of its fiftieth anniversary as we go to press. The meeting promises to be notable and to give an impulse to the work of the Association that will last for many years. Beginning with the address of the president in this number *SCIENCE* will publish full reports of the meeting.

THE French Association for the Advancement of Science has just held its annual meeting at Nantes. The President, M. Grimeaux, the eminent chemist, made an address entitled 'La chimie des infiniment petits,' reviewing the work of Pasteur and his pupils. Reports were presented by the Secretary and Treasurer. The latter showed that the funds of the Association amounted to over 1,200,000 fr., and the income for the year to over 100,000 fr. More

than 40,000 fr. were granted for scientific purposes.

OVER four hundred papers have already been promised for the several sections of the Association of German Men of Science and Physicians which meets at Düsseldorf from September 19th to 24th.

THE German Pathological Society will hold its first meeting at Düsseldorf in connection with the meeting of German Men of Science and Physicians. Professor Virchow is president of the Society.

THE funeral of the late Dr. James Hall took place in Albany on August 15th. The pall-bearers were Professor Lewis Boss, of Albany; Professor B. K. Emerson, of Amherst, Mass.; Professor J. C. Smock, of Trenton, N. J.; Professor William H. Niles, of Boston; Dr. F. J. H. Merrill and Professor J. M. Clarke, of Albany; Mr. G. K. Gilbert, of Washington, and Professor A. S. Bickmore, of New York. A memorial address was given in the cathedral by Father Walworth, who had been Dr. Hall's friend for fifty years.

PROFESSOR JOHN COMFORT FILLMORE, of Pomona College, California, died suddenly on August 14th, at Taftville, Conn., while on his way to attend the meeting of the American Association in Boston, where he was to have read a paper on 'The Harmonic Structure of Indian Music.' For the past ten years Professor Fillmore has been engaged in the study of primitive folk-song. Gifted with great clearness of perception, a courage that knew no fear of untrodden ground, and possessed of a thorough musical education, he was well equipped for the new problems which he met and mastered in his field of research. To him belongs the honor of inaugurating 'the ethnological method of scientific treatment of our music system,' to quote the words of a learned German authority, speaking of Professor Fillmore's work. His demonstration that the chord line, as that of the least resistance, was the line along which folk song was built, thus showing that harmony is fundamental to all music, ranks among the valuable contributions of science during recent years. A. C. F.

WE regret also to record the deaths of the



following men of science abroad: Dr. Axel Blytt, professor of botany at Christiania, at the age of fifty-four years; Dr. Carlo Giacomini, professor of anatomy in the University of Turin, on July 5th, and Dr. Ernest Candèz, the coleopterologist at Glain, near Lüttich, on June 30th.

THE will of the late Dr. William Pepper was admitted to probate on August 8th. A bequest of \$75,000 as an endowment for the William Pepper Laboratory of the University of Pennsylvania was revoked by a codicil dated about two weeks before his death. The codicil is as follows: "By my said will I made a bequest of \$75,000 as an endowment for the William Pepper Clinical Laboratory of the University of Pennsylvania. I have since the date of my will determined to make a gift during my life-time of \$75,000 to the department of archaeology and paleontology of the University of Pennsylvania for the purposes of the University Museum. Hoping at some future time to be in a position to carry out my original intention, notwithstanding my gift to the Museum, but finding it inconvenient at this time to make both provisions I hereby revoke the provision of the first paragraph of the third item of my said will." The executors state that Dr. Pepper did not have time to make this gift to the University Museum before his death, but that the desire of the family is to carry out his known wishes.

THE will of the late Adolph Sutro, of San Francisco, who during his life-time made liberal gifts to the University of California, sets aside 1,000 acres of valuable land in San Francisco for charitable and educational purposes.

MADAME PÉAN, in accordance with the wishes of her husband, has presented to the Hôpital Saint-Louis, Paris, his valuable collection of anatomical and pathological casts.

THE monument to Professor Wilhelm Meyer, the discoverer of post-nasal vegetations, will be unveiled in Copenhagen during October. An address will be made by Sir Felix Simon.

PROFESSOR W. M. DAVIS, of Harvard University, has sailed for Europe, where he will spend next year. Correspondence may be addressed care of Baring Brothers & Co., London.

DR. C. H. HITCHCOCK, of Dartmouth, has left for the Hawaiian Islands, where he expects to spend a year in geological exploration. His address will be at Honolulu.

WE noted last week that some anxiety was felt concerning the safety of the *Belgica*. Colonel de Gerlach, father of the commander of the expedition, has since made a statement to the effect that the steamship was provisioned for three years, and, though it may have got blocked in the ice, there is no cause for apprehension regarding its safety. The *Belgica* was expected to arrive at Melbourne last month, after having carried out explorations of Graham Land and Weddell Sea.

AT a meeting of the Council of the Royal College of Surgeons of England on August 2, 1898, it was resolved: That in view of the proposed alterations in the laws relating to vaccination now contemplated in the bill before Parliament, the Council do reaffirm the following resolution adopted by them and forwarded to the Royal Commission on Vaccination on May 11, 1893, viz: "We, the Council of the Royal College of Surgeons of England, desire to put on record at the present time our opinion of the value of vaccination as a protection against smallpox. We consider the evidence in favor of its life-saving power to be overwhelming, and we believe, from evidence equally strong, that the dangers incidental to the operation, when properly performed, are infinitesimal. Experience has satisfied us that, even when vaccination fails to afford complete exemption from smallpox, it so modifies the severity of the disease as not only to greatly reduce its mortality, but to lessen the frequency of blindness, disfigurement and other grave injuries. We should, therefore, regard as a national calamity any alteration in the law which now makes vaccination compulsory. We are, moreover, firmly convinced that revaccination is an additional safeguard and should be universally practiced. We would add that we believe that the instructions of the Local Government Board for public vaccinators are well designed to secure the greatest efficiency in vaccination and to avoid the liability to risks from the operation."

MESSERS. G. W. AND W. D. HEWITT have, as we learn from the Philadelphia *Ledger*, prepared preliminary plans for the buildings it is proposed to erect for the Philadelphia Museums. These plans are elaborate, and the structures contemplated will be enormous in size. The central building will be 208 feet square and 226 feet in height, having a central dome 100 feet in diameter. This will be known as the Administration Building. On two sides of it there will be wings, each 90 feet in width and 384 feet in length, and these will be connected by two other wings, each 80 by 300 feet, forming a hollow square. These squares will be roofed over to form immense halls or courts, 296 by 216 feet in dimensions, which it is proposed to use in connection with the other sections of the buildings for general exhibition purposes. The Administration Building, which will contain all the offices, committee rooms, library and a large assembly room capable of seating 1,500, will be six stories high, while the buildings for exhibition will be only three stories high. All the windows will be fitted with stationary sashes, and air, which has first been cleared of all dust and impurities, will be introduced by means of fans. The power house, boiler rooms, etc., will be placed along the outer line of the plot, the grade at that point being such that the boiler house roof will be on a level with the grounds of the surrounding buildings. The plans call for granite, with light gray and brick and terra cotta trimmings for the walls of the buildings, and the roofs are to be covered with slate or tile. The interior will be of fire-proof construction, plain, but substantial, especial care being given to exhibition cases and light. The proposition is to have the buildings completed in time for the exhibition, which is to take place next May.

At the recent meeting of the National Trust for Places of Historic Interest or Natural Beauty the annual report stated, according to the *London Times*, that during the past year there had been a steady growth of membership. As the aims and objects of the Trust became better known, it was more and more referred to for help and advice in the protection and preservation of places of historic interest or natural

beauty. The acquisitions of the past year had been two, each representing a different class of property. The members of the Trust had long been anxious that it should secure one of the headlands of Kent or Surrey overlooking the Weald and commanding a view of the hills, as these promontories were being rapidly purchased for building, and enclosed. During the past year that wish had been in a measure fulfilled, Mr. and Mrs. Richardson Evans and their relatives having presented to the Trust, in memory of Mr. Frederick Feeney, some land on the spur of Toy's Hill, which afforded an uninterrupted view to the South Downs. This was the first realization of the idea suggested by the Trust that memorials should sometimes take the form of beautiful scenery or of land commanding beautiful views dedicated to the memory of the dead. The adjoining piece of land on the spur had been presented to the Trust by Miss Octavia Hill. The trust had also acquired Joiner's Hall, Salisbury, an interesting old building, the impending destruction of which had too often led only to protests and vague regrets. The work of repairing the old clergy house at Alfriston was now nearly complete. A memorial stone had been erected at Barras Head recording its purchase by the Trust and its dedication to the public. With regard to Barmouth Cliff the Council regretted that the negotiations with regard to the addition of certain land to that already possessed by the Trust had fallen through. The sale of the Marquis of Worcester's Monmouthshire estate might possibly provide the Society with the opportunity of acquiring Tinturn Abbey, a piece of property of national interest. The Society hoped, as soon as the necessary arrangements could be made for their transfer, to become the trustees of the site of Driffield Castle and an old Columbarium at Garway, near Ross. The report also referred to the action taken by the Society to prevent injury and destruction, especially in regard to the St. John's Improvement and Victoria-embankment Extension Bill, the ancient camp at Uphall, near Ilford, in Essex, the Glava stones on the banks of the Nairn, Church-row, Hampstead, the old inn at Maiden Newton, the old vicarage at Luton, Christ's Hospital, the monk's barn Peterborough and several

railway projects. The statement of accounts showed a balance in hand of £191 on an income of £1,177.

THE *Elektrische Zeitung* publishes in its issues for July a long article by Dr. Zickler on telegraphy by means of ultra-violet light. According to the abstract in the *Electrical World*, it appears that he proposes a new system of wireless telegraphy, the chief object of which is to overcome the objection to the electromagnetic wave system which lies in the fact that these waves are distributed in all directions, and cannot be concentrated in one direction, all methods for doing this having apparently failed. The principle of his method, which it seems he has tried with success, is based on an observation first made by Hertz—namely, that light rays of short-wave length, especially the ultra-violet rays, have the property of promoting electric discharges—and his receiver is based on this fact. The transmitter consists of an arc light, the rays of which are condensed with lenses or reflectors into the direction in which they are to be sent, and at the receiving end the ultra-violet rays promote the discharge in a spark gap, which discharge will give rise to electric waves, which operate a coherer and through this a bell, a telephone or an ink writer; the apparatus is shown by means of diagrams. The condensing lens on the transmitter must be made of quartz, and not of glass, as the former will transmit the ultra-violet rays and the glass will not; these ultra-violet rays are shut off intermittently as desired, by means of a glass plate, which is moved rapidly in front of the camera like a shutter on an ordinary photographic camera; the ultra-violet rays will, in this way, be cut off, while there will be no apparent effect on the light rays, and for this reason the secrecy of the message will be preserved; the ordinary searchlights could be arranged to be used for the transmitter. The receiver consists of a glass tube, one end of which is made of a plate of quartz, so as to allow the ultra-violet rays to enter; these fall on a small, slanting plate in the tube, and forming one of the electrodes of the spark gap; 10 mm. from this is the other electrode, in the form of a small ball; both electrodes are mounted with platinum; the air in the tube is exhausted to a

certain degree, or is filled with a rarefied gas; the electrodes are connected with the secondary of a small induction coil, the knob being the anode and the disc the cathode; the induction coil need only give a spark of 1 to 2 cm. and should be provided with an adjustable resistance for regulating the voltage, so that it will be just insufficient to produce a spark when no rays fall on the gap; whenever the rays are received a discharge will take place; a coherer in the immediate neighborhood may be used to produce a call or any other signals. If the signals are merely to be made audible a telephone in the discharge circuit is sufficient. He begins the description of the results of a very large number of experiments which he has made, mostly with crude apparatus. He found that platinum was by far the best material for the electrodes, the charge between which is to be effected by the light; the question of the best shape of the electrodes was not so easily answered, and no definite results were obtained; the air surrounding the spark gap of the receiver was exhausted to 200 mm., which gave better results; the first tests were made at very short distances, and were then increased to 50 meters, at which very satisfactory results were obtained. Some deductions are then made from this data for greater distances, and he shows how much the light must be increased with the distance; with a 25-ampere lamp provided with a suitable reflector he thinks it will be possible to telegraph in this way to a distance of a number of kilometers; experiments with greater distances are to be carried out.

---

#### UNIVERSITY AND EDUCATIONAL NEWS.

THE London University Commission Bill has been finally passed both by the House of Commons and by the House of Lords, and London will have a teaching university as soon as royal assent has been added.

ANOTHER extremely important educational advance in Great Britain is announced in the introduction of a bill into Parliament by the government reconstructing the entire system of secondary education. There will be a comprehensive educational department presided over by a Minister of Education.



KANSAS CITY UNIVERSITY has received about \$10,000 by the will of the late John Brown, of Chilhowee.

A NEW machinery building is under construction for the mechanical department of the University of Tennessee. The University lights its own buildings and the increased demand for light will be met by a direct connected generating set placed in the new machinery building. The machine shops will also be driven by electricity from the same plant, doing away with all belting and line shafting. The new building will also contain an electrical testing room for such tests as cannot be made at the laboratories of the electrical engineering department. The old machine shop is being rebuilt to furnish an additional dormitory.

THE Commissioners for the Exhibition of 1851 have made their appointments to science research scholarships for the year 1898 on the recommendation of the authorities of the respective universities and colleges. The scholarships are of the value of £150 a year, and are ordinarily tenable for two years (subject to a satisfactory report at the end of the first year) in any university at home or abroad, or in some other institution approved of by the Commissioners. The scholars are to devote themselves exclusively to study and research in some branch of science the extension of which is important to the industries of the country. A limited number of the scholarships are renewed for a third year where it appears that the renewal is likely to result in work of scientific importance. Five scholars have been appointed for a third year, seventeen have been appointed for a second year, and thirteen new appointments have been made. Three of the scholars will work in the United States, one at Harvard, one at Cornell and one at Columbia.

A BILL has been introduced into the British House of Commons forbidding anyone to attach to his name a degree obtained abroad, without giving the source from which it has been received.

FROM official statistics published by the Minister of Public Instruction and summarized in the *British Medical Journal* it appears that on January 15, 1898, the total number of stu-

dents in the faculties and schools of superior instruction in France was 28,782. Of this number 27,911 were men, 26,419 being French, and 1,492 foreigners; and 871 were women, of whom 579 were French and 292 foreign. The total number of students in the several faculties and schools of medicine was 8,064, of whom 399 were women; of the whole number 734 male and 168 female students were foreigners. The 'extra-legal' schools of medicine outside the universities had 949 students, of whom 70 were women; while the medical schools at Algiers had 763, of whom 24 were women. There are in Paris 11,647 students, of whom 3,971 are students of medicine. Next to Paris in respect of student population comes Lyons, with 2,335, of whom 1,106, including 33 women, belong to the medical faculty. Bordeaux occupies the third place, with 2,144, of whom 737 are students of medicine. Toulouse, Montpellier, Lille, Rennes and Nancy have each over 1,000 students.

DR. JOHN C. THRESH has been appointed lecturer on public health at the London Hospital Medical College new laboratories, and a public health museum will be opened at the College at the beginning of the next session.

#### DISCUSSION AND CORRESPONDENCE.

##### AN AMERICAN BLUE GROTTTO.

MANY of the beautiful phenomena seen at the celebrated Blue Grotto of the island of Capri are reproduced on a small scale in a cavern at Lake Minnewaska, New York. This lake is situated on the Shawangunk range of mountains at an elevation of about 1,700 feet; it lies in a basin, excavated in glacial times, about half a mile long and less than a quarter in width, and of a depth reaching seventy feet. The rock on all sides is a white quartzite known as Shawangunk grit, which rests upon shale, but no outcrop of the latter is visible at the lake. The quartzite is compact to granular and contains in places pebbles of white quartz; it is very free from feldspathic admixture, so that it yields to the water very little soluble matter. Bare cliffs rising to the height of 150 feet bound the east side of the lake, while the western banks



are well wooded. The cliffs are vertical and fringed at their base by the usual talus, which, however, is made up of blocks of unusual size. The cavern is formed by several huge rocks overhanging the water so as to form a comparatively dark hole, and the space between the under side of the sloping rocks and the water varies from about two feet to not more than two inches. The cavern faces the southwest; it is very irregular in shape, and at one point the roof and walls reverberate in response to a deep bass note. The water just at the entrance to the cavern is 33 feet deep, and two or three feet away 40 feet; it is very transparent at considerable depths. As the rocks overhang so close to the water the optical effects can only be seen by a swimmer, and it was while swimming along the shore that I discovered the American Blue Grotto three years ago. As one approaches the mouth of the cavern the bluish color of the water is noticeable, but the beautiful effects are best seen by entering the opening and looking outwards towards the light. The water varies in color from Nile green through turquoise blue and sky blue to deep indigo blue, and in all these shades exhibits the silvery appearance, when agitated, characteristic of the grotto at Capri. A body immersed in the water has a beautiful silvery sheen, similar to the reflection of moonlight. The water has these colors at all hours, but they are strongest when the sun is in the zenith; late in the afternoon the slanting rays of the sun enter the opening and light up the cavern, greatly diminishing the optical effects.

The water retains the characteristic color (but without the silvery sheen) on cloudy days, and even during rain, being especially strong when fleecy white clouds bar direct sunlight. The relation between the different hues, green and blue, to the aspects of the sky, whether clear or overcast, is not evident.

Another pleasing phenomenon must be mentioned. Just below the water line, where the rocky sides are lapped by the waves, the white quartzite exhibits a brilliant siskin-green hue; this bright color is limited to a space about three or four inches below the level of the lake and to certain walls of the cavern. The bare arm immersed in the water partakes of the

green color when the light is reflected at one angle, and of the silvery blue color at another angle. The interior size of the cavern is not easily given, but the face of the overhanging rocks measures about 40 feet and they project about 15 to 20 feet, and it is surprising that so small a cavern can produce such a variety of fine effects.

The writer would like to learn, through the columns of SCIENCE, whether similar blue grottos are common at other American lakes.

H. CARRINGTON BOLTON.

LAKE MINNEWASKA, August, 1898.

#### 'THE DELUSION OF ATAVISM.'

DR. BRINTON'S recent remarks on the 'Delusion of Atavism' recall Dr. Thomas Dwight's paper on the 'Range and Significance of Variation in the Human Skeleton,' a paper which may be read with much profit by those who are bound to find some reversional character in every anatomical abnormality. As Dr. Dwight says, "if all animal resemblances are reversions, the primitive ancestor must have been a very curiosity shop of peculiarities."

F. A. L.

#### SCIENTIFIC LITERATURE.

*Technical Mycology.* By DR. FRANZ LAFAR. With an introduction by DR. E. CHR. HANSEN. Translated by CHAS. T. C. SALTER. Vol. I., Schizomycetic Fermentation. London, Chas. Griffin & Co., Ltd.; Philadelphia, J. B. Lippincott Co. 1898. Pp. 405, with 1 plate and 90 figures.

The appearance last year of the first volume of Dr. Lafar's *Technische Mykologie* relating to fermentations induced by Schizomycetes marks the gradual development of bacteriological science along other than medical lines. The interest that is attached to the study of these micro-organisms in other than their pathological relations is rapidly increasing, and we may hope that such works as these will stimulate investigation and study in a very promising field of research. The translation of this work into English by Salter will unquestionably be welcomed.

The scope of the work is the utilization of micro-organisms in the arts and manufactures.

The present volume includes those processes that are induced by bacterial organisms. A prospective volume will take up such changes as are caused by the higher fungi.

While the general purpose of the present text is to consider bacteriology in its applied phases (other than medical), still the general biological student will find much that will interest him. The exceedingly well-proportioned and thoroughly digested chapters on the historical development of bacteriology, as well as the general biology of bacteria, will be appreciated by all biologists. Technical chemists, fermentation physiologists and students of agricultural bacteriology will also find the book a great help in their work.

One striking feature of the work is the thoroughness with which the literature has been sifted. Dealing as it does with such a diversity of subjects, the labor of gathering the data from a multitude of technical as well as scientific journals has been very considerable, and the successful manner in which this has been accomplished adds materially to the value of the work.

It seems incredible, however, that the translator should allow the book to be presented to English readers without an index, even though the original lacked this necessary adjunct to usefulness. Another undesirable feature is that the copious bibliographical references are not to appear until the second volume is published, thus handicapping the utility of the book for a considerable time at least.

H. L. RUSSELL.

*The Story of Extinct Civilizations of the East.* By ROBERT E. ANDERSON, M.A., F.A.S. New York, D. Appleton & Co. 1897. 12 mo. Pp. 213.

We have here a useful little book, compiled with more knowledge and discretion than are usually discoverable in such pot-boilers. The author takes up in turn Babylonia, Egypt, the Hittites, Phenicians, Arabs and ancient Persians. He chooses his authorities judiciously, not being either tedious or frivolous.

The introductory chapter on the 'Origin and Races of Mankind' is the least satisfactory of the volume. He prefers Cuvier's classification

into three races, on the color line, which has never been accepted outside of France and is inadequate to our present knowledge. He uses 'race' in the loosest senses, 'white race,' 'Aryan race,' 'Slavic race,' etc. But these are slight blemishes, and inappreciably mar the merit of the whole.

D. G. BRINTON.

*Nests and Eggs of North American Birds.* By OLIVER DAVIE. Fifth Edition, Revised, Augmented and Illustrated. Columbus, 1898.

The first edition of this book, issued in 1885, comprised but 77 pages of pica type; the present issue contains over 500 closely printed pages. While devoting particular attention to the nesting habits and eggs of North American birds, the book contains a large amount of information concerning the distribution and life histories of birds and includes a chapter on ornithological and oological collecting. Although current ornithological literature has been freely drawn upon by the author, he has also availed himself of the work of a large number of active field ornithologists who have placed at his disposal their notes on the eggs, nests and nesting habits of various species. The full citation of the numerous authorities adds greatly to the value of the work, which should retain the popularity accorded it since its first appearance.

F. A. L.

NEW BOOKS.

*Psychology for Teachers.* C. LLOYD MORGAN. With a Preface by HENRY W. JAMESON. New York, Charles Scribner's Sons. 1898. Pp. xi+240. \$1.00.

*Proceedings of the Society for the Promotion of Engineering Education.* Vol. V. Published by the Society. 1898. Pp. xxii+337.

*New York State Museum.—Fiftieth Annual Report of the Regents.* 1896. Vol. I., Report of Director, Botanist and Entomologist. Albany, The University of the State of New York. 1898.

*Special Report of the U. S. Department of Agriculture on the Beet Sugar Industry in the United States.* Washington, Government Printing Office. 1898. Pp. 230.

# SCIENCE

EDITORIAL COMMITTEE: S. NEWCOME, Mathematics; R. S. WOODWARD, Mechanics; E. C. PICKERING, Astronomy; T. C. MENDENHALL, Physics; R. H. THURSTON, Engineering; IRA REISEN, Chemistry; J. LE CONTE, Geology; W. M. DAVIS, Physiography; O. C. MARSH, Paleontology; W. K. BOOKS, C. HART MERRIAM, Zoology; S. H. SCUDDER, Entomology; C. E. BESSEY, N. L. BRITTON, Botany; HENRY F. OSBORN, General Biology; C. S. MINOT, Embryology, Histology; H. P. BOWDITCH, Physiology; J. S. BILLINGS, Hygiene; J. MCKEEN CATTELL, Psychology; DANIEL G. BRINTON, J. W. POWELL, Anthropology.

FRIDAY, SEPTEMBER 2, 1898.

THE FIFTIETH ANNIVERSARY OF THE  
AMERICAN ASSOCIATION.

## CONTENTS:

<i>The Fiftieth Anniversary of the American Association</i> .....	269
<i>A Greeting to the Boston Meeting of the American Association for the Advancement of Science: PRESIDENT J. M. CRAFTS</i> .....	274
<i>Destructive and Constructive Energies of our Government Compared: PRESIDENT CHAS. W. ELIOT</i> .....	277
<i>A Half Century of Evolution, with Special Reference to the Effects of Geological Changes on Animal Life (II): PROFESSOR ALPHEUS S. PACKARD</i> .....	285
<i>Earthquakes: PROFESSOR EDWARD S. HOLDEN</i> .....	294
<i>Zoological Notes: F. A. LUCAS</i> .....	296
<i>Current Notes on Anthropology:—</i>	
<i>Indeterminate Forms of Chipped Stones; Was Buddha a Mongolian? Mexican Antiquities: PROFESSOR D. G. BRINTON</i> .....	296
<i>Notes on Inorganic Chemistry: J. L. H.</i> .....	297
<i>Scientific Notes and News:—</i>	
<i>Indiana University Biological Station; Christmas Island; General</i> .....	298
<i>University and Educational News</i> .....	301
<i>Discussion and Correspondence:—</i>	
<i>On the Occurrence of Placocephalus (Bipalium) Keweenaw in the Sandwich Islands: DR. W. MC M. WOODWORTH</i> .....	302
<i>Scientific Literature:—</i>	
<i>Halévy on La Théorie Platonicienne des sciences: PROFESSOR PAUL SHOREY. Archibald's Story of the Atmosphere: DR. FRANK WALDO</i> .....	302
<i>New Books</i> .....	304

THE American Association for the Advancement of Science celebrated the fiftieth anniversary of its foundation at Boston from the 20th to the 27th of August. The meeting, as all knew would be the case, was eminently successful, both in regard to the scientific work accomplished and in the occasions for social intercourse and enjoyment so liberally provided. As stated in the report of the new Permanent Secretary, Dr. L. O. Howard, at the closing session, the meeting was in many respects the most successful in the history of the organization. In point of numbers the attendance made it the fourth meeting in the history of the Association. Two of the meetings which have exceeded it in attendance have been held in conjunction with the British Association for the Advancement of Science, and the third was held in Boston; so that Boston has been excelled only by Boston. The scientific and other advantages of Boston, and the fact that the meeting celebrated the fiftieth anniversary of the founding of the Association, attracted members in large numbers. The total registration was 903, and almost every State in the Union was represented. The State which had the largest representation was naturally Massachusetts, with a total of 231; New York came second, with 158, and the District of Columbia third, with 96.

MSS. intended for publication and books, etc., intended for review should be sent to the responsible editor, Professor J. McKeen Cattell, Garrison-on-Hudson, N. Y.



The other States were represented as follows: Pennsylvania by 55; Ohio by 53; Connecticut, 29; New Hampshire, 23; Michigan, 23; New Jersey, 20; Maryland, 19; Wisconsin, 18; Missouri, 17; Illinois, 15; Rhode Island, 14; Indiana, 12; Maine, 10; Virginia, 10; Iowa, 10; Vermont, 7; Minnesota, 7; North Carolina, 6; Florida, 6; Kansas, 5; Mississippi, 5; Kentucky, 5; West Virginia, 4; Georgia, 4; Louisiana, 3; Tennessee, 3; Texas, 3; Colorado, 3; South Carolina, 2; Nebraska, 2; and Montana, North Dakota and California, 1 each.

The term American has always been held by the Association to include not only citizens of the United States, but of other American countries, and members from Canada have always been present at the meetings. At this session there were present 16 members from British North America. There were representatives from other countries in attendance. The Republic of France sent an official representative, who, with his wife, appears upon the registration list of the meeting. Moreover, three persons have registered from Great Britain; one from New South Wales; one from Brazil, and one from Japan.

Not alone in point of the numbers in attendance was the meeting remarkably successful. More papers than usual were read before the different sections, and it is unnecessary to make the statement that the character of these papers as a whole was of the highest order. Considering that during the week an entire day was spent at Salem at which no papers were read, and that another day was spent at Cambridge during which but few papers were read, and that the first day, Monday, was entirely occupied by the general session and the delivery of the addresses of the Vice-Presidents, it is remarkable that the Association should have completed the reading and discussion of so many different papers. In all 443

papers were considered during the week. Of these 39 were presented to Section A; 51 to Section B; 90 to Section C; 20 to Section D; 54 to Section E; 35 to Section F; 56 to Section G; 10 to the Botanists' Club; 55 to Section H; 33 to Section I.

The success of the Boston meeting was further very marked in the attendance of so many of the older and more prominent men of the United States. No less than nine past Presidents of the Association took part in the discussions of the week, and in this fact, no less than in the greatly increased attendance over that of the last meeting, is to be seen most encouraging signs of the future of the Association.

The first general session of the Association was called to order by the retiring President, Professor Wolcott Gibbs, at 10 o'clock on the morning of August 22d. Addresses of welcome were made by His Excellency, Roger Wolcott, Governor of Massachusetts; His Honor, Josiah Quincy, Mayor of Boston; and President James M. Crafts, of the Massachusetts Institute of Technology, to which a reply was made by President Putnam.

The address of Governor Wolcott, as reported in the *Transcript*, was in part as follows: It is with far more than ordinary pleasure that, on behalf of the Commonwealth, I extend a most cordial greeting to those who are present here to-day. The American Association for the Advancement of Science on this, its fiftieth anniversary, has done well to return to the soil of the Commonwealth which was the place of its birth and which gave to it its charter. I welcome you all—those who come from the many cities of our country and those who come from foreign lands. The Commonwealth is honored by your presence. As seekers after truth, you have devoted your lives to following the footsteps of science, whether her majestic way is across conti-



nents, following the pathway of stars, or whether she delights to follow the minutest particles revealed by microscopic research.

Governor Wolcott then described at length in an eloquent and scholarly manner the many benefits coming to the world by the researches of men of science, and, continuing, compared them to the men who have erected lighthouses on the coast, guiding and directing the course of those who will come after them. He spoke of the infinite possibilities of science, and said that, in spite of the great advances that have been made, little is known to-day of the mysteries of nature, so elusive is its touch.

It is for you, he said, little by little, as the years and centuries go on, with faithful and painstaking search, to learn a little more of that great ocean of truth and to launch your barks a little farther on the sea of science, and to know more about the stars, the plants, the pebbles and the shells. The truth is that science is still sweeping beyond you and is beckoning you to follow her. Science would be less worthy of our regard if its benefits should be limited to any class, but it is open to all.

It is as men of science that the Commonwealth welcomes you to-day. May you bear away from this meeting pleasant memories of the State, rich in the valor and achievements of her sons. And may you leave behind you that inspiration which is fostered and cherished by men who are brought together to compare notes and clasp hands and carry back memories of this meeting. The Commonwealth greets you and expresses to you her recognition, and bids you welcome to the old Bay State.

Mayor Quincy, being introduced, spoke as follows: We are grateful to you for giving us an opportunity of seeing you here, that we may listen to your deliberations and exercises, and for having the privilege of entertaining you in some measure. I may say in truth that there

is no other city in this country which would appreciate more highly the privilege of having this anniversary meeting held within its borders than the city of Boston. I think I may claim with truth that in no city is science held in higher esteem, in no city is the great work of science and the widespread beneficence of its results more recognized than in the city of Boston. There is no organization to which we would more gladly open our doors than to your American Association for the Advancement of Science. Your work has a very direct relation to the work in which the people of the city of Boston are engaged, in their corporate capacity, and the work which their municipal government is trying to prepare for them. As I regard it, the work of good municipal government is the task of securing the practical application of the principles of science to the great fund of knowledge which has been won for us by science. I am continually impressed in my practical relation to the work of this great city with the vital relation which science bears to that work. More efficient government is to be sought along the lines of affairs which fall within the scope of our municipal government, and this is to be won for us by the investigators who have increased their knowledge of science within the last fifty years.

I trust and believe that this interesting occasion may do something for us as well as something for the American Association for the Advancement of Science, and I hope that among other benefits it may give to our citizens as a whole a greater appreciation of what science is and of what science does; and not only of what science does in the abstract or in the way of theoretical investigation, but demonstrate the value of science as the handmaid of civilization which enlarges the views of mankind and lifts society up to the highest plane of thought. If the first result is economy in

its relation to humanity; if its first effect is to enlarge our minds and give us a wider power of interpretation of nature, to harness more effectually the forces of the great mother, and to save labor, it has no less surely its social and its intellectual side. First is to be considered the economical possibilities, which mean easier living with infinite improvements in the art of living, and after it comes the advancement of all humanity and the more complete progress which must accompany social uplifting. We are endeavoring in a partial and incomplete way to apply some of the principles of science to the practical benefits of the one-half million people within the limits of this municipality. I am proud to say that we give a high place in everyday work to men of science who are giving technical application to the principles which have come to light through the investigations of abstract science. Work in the future will demand a fuller employment of men of science. I am proud to say that we are commanding the interest and the services and the hearty cooperation, without price and without regard, of men who are endeavoring to give in some measure a practical social science, and, while this may be a far less exact science than many others, I firmly believe that there is a social science and a political science, and that the domains which come within its knowledge are constantly widening, both as regards the body social and its evolution and the body politic and how to secure its best application. I heartily congratulate the American Association and welcome it back, after fifty years, to the scene of its birth, and extend thanks and welcome, on behalf of the city of Boston, to each and every one of its members, in view of this meeting here and the work which the Association is yet to do in the first half of the century to come.

President Crafts, of the Massachusetts

Institute of Technology, followed Mayor Quincy, and made a most interesting address, which is printed in full below.

President Putnam, on being introduced by the retiring President was heartily cheered, all recognizing that his services as Permanent Secretary for twenty-five years had been the chief factor in the great growth and success of the Association, while his own contributions to science had given him a double claim to the highest office in the gift of the Association at this anniversary meeting. President Putnam made an address which it is hoped may be subsequently published in this JOURNAL.

M. Charnay, the official delegate from the French government, was introduced and spoke briefly in French. A message was also read from the Russian Geological Committee of St. Petersburg sending congratulations and good wishes. After listening to announcements of the Local Committee the session adjourned.

In the afternoon the Vice-Presidents gave their addresses before the different Sections as follows :

Section A. Mathematics and Astronomy: Development of Astronomical Photography; Vice-President Barnard.

Section B. Physics: On the Perception of Light and Color; Vice-President Whitman.

Section C. Chemistry: The Electric Current in Organic Chemistry; Vice-President Smith.

Section E. Geology and Geography: Glacial Geology in America; Vice-President Fairchild.

Section F. Zoology: A Half-century of Evolution, with Special Reference to the Effects of Geological Changes on Animal Life; Vice-President Packard.

Section G. Botany: The Conception of Species as Affected by Recent Investigations on Fungi; Vice-President Farlow.

Section H. Anthropology: The Advance of Psychology; Vice-President Cattell.

Section I. Economic Science and Statistics: The Historic Method in Economics; Vice-President Blue.

Vice-President Cooley, of Section D, Mechanical Science and Engineering, having been detailed to active service in the navy

was unable to be present, but the Section was addressed by Professor R. H. Richards, his subject being 'Ore-Dressing.' The addresses of the Vice-Presidents will be published in full in SCIENCE.

In the evening the retiring President gave the highly important though somewhat technical address 'On Some Points in Theoretical Chemistry,' printed in the last number of this JOURNAL.

The work of the Sections was chiefly confined to the morning, afternoon and evening of Tuesday and Thursday, though some of the Sections held sessions on Friday and Saturday. The scientific papers presented will be adequately reported in subsequent issues.

Wednesday was devoted to an excursion to Salem and neighboring places of scientific and historic interest. By invitation of the President and Fellows of Harvard College, the members of the Association were guests of Harvard University on Friday. The scientific museums and laboratories were visited under the guidance of the heads of the departments, and in the evening President Eliot made a most admirable address, a report of which is given below. Among the other entertainments provided for members were receptions by the trustees of the Museum of Fine Arts, and the officers of the public library, by Governor Wolcott, Mrs. W. B. Rogers and Mrs. J. C. Phillips. Mayor Quincy entertained the principal officers of the Association and several foreign guests at dinner on Tuesday evening. There were also private dinners and receptions given to various members. Many interesting excursions were arranged by the Appalachian Mountain Club, including an extended trip to the White Mountains, following the meeting.

During the meeting the Council held frequent sessions. Several alterations in the Constitution, which will be acted on at the next meeting, were recommended. A num-

ber of fellows were elected, including several leading men of science. Grants of \$50 each were made to the Committee on Standards of Measurement for work being carried on by Professor H. S. Carhart, and to the Committee on the Ethnology of the White Race in America, for instruments to be constructed by Professor J. McK. Cattell. Other applications for grants were laid on the table on the ground that they did not fill the conditions of a resolution passed by the Council which was as follows:

*Resolved*, That grants be awarded under the following conditions:

- (1) That a formal request be received for such grant.
- (2) That a grant be awarded for a specific investigation only.
- (3) That a report be submitted to the Association describing the results of such investigation.

The Council authorized Section H (Anthropology) to hold a winter meeting in December, 1898. This will be held at Columbia University, New York, in connection with the meeting of the American Society of Naturalists and affiliated societies, and at the same time a meeting of the Council of the Association will be held.

The concluding general session on Saturday morning was chiefly devoted to the customary addresses of thanks, which this year were presented with unusual cordiality. Dr. McGee offered the resolutions, and short addresses were made by M. Charnay, Dr. Brinton, Dr. Hovey, Professor Sedgwick, Professor Tyler, the Rev. Dr. E. E. Hale and President Putnam. A report was made to the Association of the work of the Council, including the announcement that Columbus, Ohio, had been chosen as the next place of meeting, and that the following officers had been elected for the ensuing year:

*President*: Edward Orton, President of Ohio State University.

*General Secretary*: F. Bedell.

*Secretary of the Council*: Charles Baskerville.



*Treasurer* : R. S. Woodward.

*Vice-Presidents* :

Section A. Alexander MacFarlane.

Section B. Elishu Thomson.

Section C. F. P. Venable.

Section D. Storm Bull.

Section E. J. F. Whiteaves.

Section F. Simon H. Gage.

Section G. Charles R. Barnes.

Section H. Thomas Wilson.

Section I. Marcus Benjamin.

*Secretaries of Sections* :

Section A. John F. Hayford.

Section B. William Hallock.

Section C. H. A. Weber.

Section D. James M. Porter.

Section E. Arthur Hollick.

Section F. Frederick W. True.

Section G. W. A. Helleman.

Section H. George A. Dorsey.

Section I. Calvin M. Woodward.

JAMES McMAHON,  
*General Secretary.*

A GREETING TO THE AMERICAN ASSOCIATION  
FOR THE ADVANCEMENT OF  
SCIENCE.\*

To the greetings which have been so cordially offered to you in behalf of the State and of the City it is my privilege to add a few words of welcome from the Institute, which is honored by your visit to-day.

You have not often favored us with your company, for you waited until the 29th year of the foundation of the Association before you held your first Boston meeting. Now twenty-one more years have elapsed before you visit us again, and we are pleased that it should be for the purpose of holding your semi-centennial anniversary in this city.

If your visits, like those of angels, are rare they are all the more highly prized,

\*By President J. M. Crafts, Massachusetts Institute of Technology, at the opening session, August 22, 1898.

and many of us feel that we must make the most of this one, because we may not, in the course of nature, hope to live to see you with us again, if your orbit is fixed by the intervals of your past appearances. While saying that you waited twenty-nine years before making your first call upon us, it should be added that long ago, in 1849, the second meeting of the Association was held in Cambridge, and that the Bostonians had the advantage of participating in that meeting in the same way that now our good neighbors of Cambridge and of other near places join in welcoming you to this one.

At the date of the Cambridge meeting Harvard College was 213 years old, and the institutions of Boston and of the neighborhood which now have the honor of greeting you were unborn and unthought of. Since that time Tufts College, Boston College, the Massachusetts Institute of Technology, Boston University and Wellesley, naming them in the order of their foundation, have grown up like young plants, and, notwithstanding the rapid increase of Harvard University, they surpass it at present in the number of their students. The total adds up to nearly 8,000 students and more than 800 teachers, about the same number as at the University of Paris.

It would be a poor greeting to deluge you with statistics, but I trust you will pardon these few, which are meant to show that since you have visited us we have been diligently occupied in preparing a fitting audience to meet your second, or rather your third coming, for the teachers and students in these colleges have come in larger part from New England, and particularly from this neighborhood, and, their education finished, they have remained in their New England homes, and whatever has clung to them of their college life is potent in shaping the modes of thought of their community. This center of education, then, is one of the largest in the world, and it is eager to give



you the kind of reception which you will most prize, those tokens of sympathy, of respect and of appreciation which spring from knowledge; for educated men know that men of science are discovering those truths which form the newest and truest part of their education. Sometimes the surroundings of a scientific man impress upon him a sense of isolation. He is asked: What good are such things? when he has discovered a new formula or a new exhibition of energy or a new substance, or has dissected the nervous system of a worm. He has no leisure to answer such questions, but he works on contented if he is not disturbed, and expects little applause unless he turns out a salable product. Let him, however, come in contact with those whom modern methods have trained to some knowledge of science, and he immediately finds ready support and sympathy and some share of the enthusiasm which he feels himself.

It is now as much a part of a good education to know something of scientific facts as it is to know the causes which led to the fall of the Roman Empire. I do not mean that we make scientific men of the great body of our students any more than the study of history transforms scholars to statesmen. When freshmen enter our laboratories we have small hope that they will make original discoveries, but we are well content if, while fitting themselves for some practical occupations, they learn the great lesson that new truths can only be found out by observation and experiment, and if they learn habits of honesty of thought by dealings with nature, which never lies. These men form the great public who have come forward so willingly and so generously to lend a helping hand to science. Perhaps in their college life their unskilful experiments have taught them to admire the skill which has made yours successful, their attempts at observation have

given them some idea of the acuteness of powers which can be acquired by long years of faithful training.

Those who have pleasure in scientific occupations are ready sympathizers, and know something of the joy which a discovery brings with it even if there is no money in it. As to those among us—and there are many who have devoted their lives to scientific work—I have no need to assure you of their hearty welcome, of their desire to meet you in this congress, and to listen to the news of your latest achievements and perhaps to tell you some of theirs. Your connection with our colleges is very direct, for many of the members of this Association have taken a leading part in this work of education, and in this neighborhood we have been fortunate in our teachers. Scholars who have walked the fields with Gray and Agassiz, who have learnt their mathematics from Peirce, their anatomy from Wyman, or their chemistry from your retiring president, might look the world over without finding leaders better fitted to guide them to the innermost chambers of scientific knowledge. In this place it is most fitting to mention the chairman of the first meeting of this Association, William B. Rogers, who was a born educator. He loved science for its own sake, and he had a patriotic desire to see his country call upon science to aid in its material progress. His efforts began so far back as 1828, when he thought it useful to lecture to the American people in Baltimore upon the advantages which he hoped would be derived from building railroads in this country. He demonstrated the known principles of railroad building, and showed that traction upon smooth iron rails was possible. Afterwards, when he came to Boston, his thoughts were full of a project for interesting the community in providing means for the education of men to direct our growing industries. This Institute was

founded, and this building erected because Rogers knew how to make science popular; his contagious enthusiasm inspired many co-workers who have not yet ceased in their task. With great simplicity of character he united an ardent imagination which gave a singular fascination to his public exposition of scientific truths. You perhaps know him best through his earliest endeavors for the foundation of the Geological Society, and you know that, later, just 50 years ago, he contributed with all his heart to the formation of this Association. His later years were devoted to the Institute which he built up, and which now, largely grown from small beginnings, has the honor of welcoming you this day; and it was on this stage that he fell, an unfinished sentence on his lips, giving his life to the cause which overtaxed his strength.

The memories which attach themselves to this place have led me to speak thus at length on this fiftieth anniversary of one who was a principal founder of one Association, and yet other memories crowd into this hall.

The Lowell lectures have been held here for many years, and to your Association belong many of the eminent men who have stood upon this platform, and who have done much to make the Boston public no stranger to scientific assemblies. Some sixty-five years ago the strongest interest in lectures was excited in New England by the qualities of certain lecturers. The eloquence of Edward Everett, the character, the new doctrines and the fascinating delivery of Emerson made men feel that book knowledge was of little worth, and that the living voice was the true means of communication with man. It seems like the difference between reading testimony or hearing a witness. Under these impressions John Lowell, Jr., a young man of 34, after the misfortune of losing wife and children, made a will by which he devoted half his

fortune to founding courses of free lectures. His death happened soon after in a foreign land, and the fund came into the hands of his cousin, John Amory Lowell, who made its care and administration the chief occupation of his life and has been succeeded in the charge by his son. In these hands the Lowell lectures have grown to be the largest enterprise of the kind in the world. The fund suffices to maintain 500-600 free lectures yearly, and to offer inducements to the most distinguished men in all English-speaking lands to come to speak to Boston audiences. We owe to this enterprise the visit of many a man of science to this country, and, in one notable case, a permanent settlement. You all know that Louis Agassiz was called to the United States to deliver a course of Lowell lectures, and that he became as good a citizen as he was a savant.

As you will see by the guide-book prepared for the use of the Association, great libraries and museums have kept pace with the intellectual and material growth of the community, and the needs of science are represented in them as well as those of art and literature. Our museums depend more than other institutions upon popular appreciation for their support, and calls upon public liberality must be seconded by a presentation in some striking and evident way of the aims and scope of the work which the collections illustrate. I cannot help thinking that your presence and your discussions, and the effort which you make to come each year, often from great distances, contribute notably to keep the cause of science before us, and that you aid in its task each community you visit.

As you watch the motions of the stars, or make experiments in laboratories, or observations in the fields, or build bridges, as you seek to cure disease and alleviate pain, or reduce the actions of mankind to fixed laws, you doubtless have sometimes in view

your summer meeting, and look forward to talking over with each other your discoveries and your difficulties, and as you are willing to do this in public, the whole community as your place of meeting comes to a better knowledge of the beautiful, earnest, skilful effort which makes up the life of a man of science. It is not a congress to adjust conflicting interests or for displays of oratory which lead to no conclusions. We get to know the man himself, and I think he would be even more popular than he is at present if we could invent some suitable name for him. Scientist is a most ill-sounding word. The French term *savant*—a knowing one—might provoke a smile, when contrasted with the simplicity of character of many men of science, but perhaps after all this is your best title to fame. Your discussions do not often degenerate into disputes, because for the first time in the history of the world methods of work have been found so sure that the results can be accepted almost without discussion. Even the geologists come to an eventual agreement about their theories, and the account which Bret Harte has given about their meetings must not be taken too literally. You are good witnesses and generally agree upon your facts, and when facts lead to differences of interpretation the single-minded desire to reach the truth brings you into accord at last.

We have good reason for welcoming you among us, and although you do not come as missionaries we shall find ourselves the better for your coming.

---

*DESTRUCTIVE AND CONSTRUCTIVE ENERGIES  
OF OUR GOVERNMENT COMPARED.\**

WE have been witnessing during the past five months an extraordinary exhibition of

\* Abstract of an address given by President Eliot, of Harvard University, before the American Association for the Advancement of Science, in Saunders Theater, on August 26, 1898.

energy on the part of the government of the United States in making sudden preparation for the war with Spain and in prosecuting that war to a successful issue. As men of science, or teachers or promoters of science, we have a special interest in the lessons of the war, because the instruments and means used in modern warfare are comparatively recent results of scientific investigation and of science applied in the useful arts. Moreover, the serviceable soldier or sailor is himself a result, not only of moral inheritance and instruction, but of training in the scientific processes of exact observation, sure inference and accurate manipulation. It is not the linguistic side of school training which makes the effective soldier or sailor; it is the scientific side. His vocabulary may be limited, though expressive, and his grammar false; but his eye must be true, his judgment sound and prompt, and his hand capable of using instruments of precision. The first-relief package, which every soldier carries, is crammed with surgical knowledge which the world waited for till the last quarter of the nineteenth century. Physiological science has really arrived at valuable conclusions with regard to the soldier's diet—the indispensable foundation of his effectiveness. Financial science is also a contributor of prime importance, since success in war depends more and more on the command of money and credit. To this war with Spain we owe the most effective revenue bill, or rather the only comprehensive revenue bill, the country has had within a whole generation.

It cannot be doubted, then, that the energy put forth by our government for the immediate purpose of capturing or destroying Spanish vessels, forts, towns and war material, and incidentally killing, wounding and starving Spaniards has been a great exhibition of power in applied science, and as such must commend itself especially to



the attention of this Association. I hear already a protest against the thought that men of science can have any special interest in war—war, the supreme savagery, the legalization of robbery and murder, the assemblage of all cruelties, crimes and horrors set up as an arbiter of international justice. But the man of science has another view of war. He regards it as the worst survival of savage life, still occasionally unavoidable because of other survivals of the savage state, such as superstition, passion uncontrolled, and lust of wealth and power. He recognizes the fact that war makes a temporary and local hell on earth, and that all its characteristic activities are destructive; whereas all the normal activities of a free government should be constructive, and intended to promote the good of its citizens and general civilization; but he does not accept Sumner's dictum in his oration of 1845 on the 'True Grandeur of Nations'—"there can be no war that is not dishonorable." He recognizes that occasional war, and therefore constant preparedness for war, are still necessary to national security, just as police, courts, prisons and scaffolds are still indispensable to social order and individual freedom in the most civilized and peaceful States. Moreover, the man of science perceives that, while the immediately destructive objects in war are savage and barbarous, the instrumentalities and forces used in modern warfare are closely akin to the great constructive agencies and forces in human society. The applications of Bessemer steel in war are not its primary uses; its peaceful constructive applications give it its primary value. The application of compressed air for the transmission of power was not invented for the dynamite gun, but for tunnelling and mining. No nation can now succeed in war which has not developed in peace a great variety of mechanical, chemical and biological arts. Now, the normal activities of

these arts must and do tend to advance human civilization. Their application to the destructive cruelties of warfare is abnormal. Yet, inasmuch as they are applied in war with a prodigious energy and intensity, it may well be that the acute horrors of even the shortest war may have a lesson for the long normal periods of peace.

Men of science, so far as I have observed, do not consider the martial virtues—courage, endurance, loyalty and the willingness to subordinate self-interest to the interest of clan, tribe or nation—to be the supreme and ultimate objects towards which the human race must struggle on. They regard these virtues as the elementary, fundamental, preliminary virtues, which can be cultivated in man's savage state, and so become the stepping-stones of his moral advance; but they know, on the demonstrative evidence of both history and natural history, that these virtues may co-exist with cruelty, rapacity and lust, and an almost complete indifference to both truth and justice. Civilization, in their eyes, means the adding of justice, truth and gentleness to the martial virtues, an addition which does not necessarily involve any countervailing subtraction. Truly, it is not war which prepares men for worthy and successful lives in times of peace. On the contrary, it is worthy life in time of peace on the part of individual men, or a nation of men, which prepares for success in war. Do we not all believe that the normal activities of peace under free institutions are the best possible, though not the only necessary, preparation for inevitable war, and that such normal activities never need to be, and never can be, purified or uplifted by avoidable war? Nevertheless, we may believe that some lessons for times of peace can be drawn from the prodigiously stimulated activity of the government and the sacrifices of the people in time of war.

The first important inference which may



be drawn from the experience of our government and people during the past five months is anthropological—it is the permanence of the martial virtues and their commonness. In any vigorous race these virtues may fairly be called inextinguishable. Civilized society is always maintaining a perilous conflict against natural forces, which ordinarily serve man's purposes, but sometimes try to overwhelm him. Fire, the greatest of man's inventions and his humblest servant, suddenly breaks out into destructive fury; wind ordinarily fills his sails, turns his mills and refreshes the atmosphere of his cities; but now and then in spots sweeps from the surface of the earth and sea all man's works—crops, buildings, vehicles and vessels. The mineral oil which every night lights so brilliantly the humblest homes in every clime occasionally kills the ignorant or careless user or sets a huge city in flames. Any single-minded worm or insect will be too much for man, unless man knows how to set some other creature of one idea at destroying the first invader. How small is the range of the thermometer within which men can live with comfort or even safety! A change of a few degrees below or above the normal range sets him fighting for his life. This conflict with external nature is the great school of mankind in courage, persistence, patience and forethought, and mankind never needs any other. It is, then, the regular pursuits and habits of a nation in times of peace which prepare it for success in war, and not the virtues bred in war which enable it to endure peace.

The second lesson to be drawn from the recent experience of the nation in war is the immense value of long prepared, highly-trained public service. The instant efficiency of our navy is a striking demonstration of this principle, which, of course, needs no enforcement before men devoted to science, but does need to be brought home to

the great body of our people. The preparedness of our regular army for immediate service, and the comparative unreadiness of the militia, even in those States which have paid most attention to volunteer military organization, enforce the same lesson. Would that the plain teaching of this short war in this regard might sink into the minds of our people, and convince them of the immense advantages they would derive from a highly-trained, permanent, civil service in every branch of the public administration.

Another lesson of these pregnant months relates to a principle which underlies our form of government, but is often seen but dimly by portions of our people. I refer to the principle that the government of the United States should do nothing which any other visible agency—State, city, town, corporation or private individual—can do as well. This seems a strange principle to be enforced by the action of our government in time of war, since the government has a monopoly of this hideous activity; but this war has brought out in a very striking way the fact that, when it comes to the pinch, the source of victory is in the personal initiative of each individual commander and private soldier or sailor. In warfare, as in industries, the automaton counts for less and less, and the thinking, resourceful individual for more and more. The automaton is the natural result of despotic institutions, civil and religious; the resourceful, initiating individual is the natural product of free institutions, under which the citizens are as little restricted as possible in the development and training each of his own will-power and capacities. To secure this fundamental advantage of free institutions, as many fields of activity as possible must be left open to the individual and to voluntary associations of individuals. The maxim 'in time of peace prepare for war' means, therefore,

vastly more than it used to. It no longer refers chiefly to the provision of vessels, forts and weapons, but rather to the bringing-up of generations of young men trained by school, college, political life and the great national industries to habits of self-direction and of disciplined cooperation. This bringing-up is best secured under free institutions, which leave everything possible to the initiative of the citizen.

This principle—that government should do nothing which any other agencies can do as well—being admitted and established, the next question to be considered is whether the legitimate activities of our government in time of peace, activities directed toward constructive and wholly beneficent objects, should not be increased. On this point I cannot help thinking that the lesson of the war is plain and convincing. It is undeniable that our people have rejoiced in the exhibition of power which the government has given during this war. We have all derived great satisfaction from our government's display of power, exercised with promptness, foresight and the sagacious adaptation of means to ends. It is human nature always and everywhere to enjoy such success as the government has won, even when it costs heavily in blood and money. To have the consciousness of possessing power, and to display the power possessed, is a national gratification. Now, this sort of satisfaction ought to be obtainable in peace as well as in war; so that the power of the United States, displayed in peace for ends wholly constructive and beneficent, ought to be in some measure comparable with the power the government is capable of displaying for destructive ends in war. How can the United States put forth, during the long periods of peace, a beneficent power comparable to the destructive power it wields in war, without violating the principle of leaving to its citizens every field of activity which they can till to advantage.

If we examine the fields of activity which must perforce remain to the government we shall find that they will amply suffice for the exercise of power enough to gratify the most ambitious and the most benevolent citizen of the Republic. Let us briefly survey some of these fields. The first I shall mention is the fostering of commerce. This function obviously belongs to the general government, which has power not only to regulate, but to annihilate at will, the trade of its citizens with foreign countries. The war with Spain has distinctly enlarged the moral outlook of our people. It has presented to them wholly unexpected problems concerning the responsibility of a fortunate people for the welfare of the less fortunate. It has suggested to them that a policy of political seclusion and commercial isolation is not worthy of a strong, free and generous people, and that such a policy is not the way to the greatest prosperity and the most desirable influence.

Another great field of beneficent activity for our government is the procuring of just and humane conditions of labor in industries which cannot be carried on within the jurisdiction of any single State, because they necessarily cover several States. The great functions of the national government in this respect are now only beginning to be exercised. In the Ninth Annual Report of the Inter-State Commerce Commission on the Statistics of Railways in the United States, a report dated June 30, 1897, I read that in the year 1896 the number of railroad employees killed in the service was 1,861, and the number injured 29,969, the number of men employed on the railroads of the United States in that year being 826,620. In the same year there were killed and wounded in coupling and uncoupling alone 6,614 trainmen, 1,744 switchmen and flagmen, and 328 other employees, making a total of 8,686 killed and wounded in coupling and uncoupling alone. Do not

these terrible figures suggest that our government has not yet undertaken to discharge its duty of protecting by legislation large classes of its citizens engaged in indispensable service to the community?

As time goes on, it appears that more and more industries have a national scope. Thus, it may be doubted whether the mining of soft coal can be successfully regulated by the separate legislation of single States; for coal mined in Virginia is necessarily in competition with coal mined in Ohio, for example, and the unprotected condition of laborers in Ohio may prevent the adequate protection of coal miners in Virginia. Interests common to many States certainly suggest that the common government has duties in regard to them.

An established function of our national government is the execution of public works for the improvement of rivers and harbors—works which redound to the advantage of the localities where they are situated, to be sure, but also to that of the people at large. These works are too often executed in a slow, wasteful manner, which no private person or corporation could possibly afford. As an illustration of bad government methods, and, therefore, of the possibilities of improvement in governmental efficiency, I take the Columbia River at the Cascade Gorge. This improvement comprises works on a lock and on a canal about three thousand feet long. The original estimate of the cost was a million and a-half dollars, and the work was actually begun in 1878. At the end of 1891, when \$1,609,324.94 had been expended on the work, the estimate for its completion was a million and three-quarters dollars. It is not yet finished, after the lapse of twenty years. It is impossible for the nation at large to take satisfaction in grand works so feebly conducted. Such a process impairs, rather than increases, the self-respect of the nation; for everybody

perceives that it is a stupid and discreditable process. Whenever a public work must be completed before the country can derive any benefit from it the government should prosecute the work with all the dispatch consistent with thoroughness of execution. This single instance illustrates the opportunities which exist for immense improvement in the conduct of the operations of our government on public works.

To illustrate further the directions in which the beneficent expenditures of our government might reasonably be increased, I now invite your attention to certain comparisons between items of military and naval expenditure which the war has forced on our attention, and the cost of some government establishments which are of special interest to the Association. The annual cost of the lighthouse establishment, on the average of the five years from 1893 to 1897 inclusive, was three million dollars. The cost of maintaining naval vessels in commission during the year 1897—a year of peace—was nine millions of dollars. Now, the lighthouse establishment is one of the most interesting and useful departments of national expenditure. It has a high scientific quality, and also a protecting, guiding, friendly quality. It calls forth in high degree the best human qualities—intelligence, fidelity and watchfulness. With our resources and our commercial needs, and our thousands of miles of coasts and rivers, our lighthouse establishment ought to be the best in the world, as well as the most extensive. Indeed, it ought to be absolutely as good as it can be made.

The progress of medical science imposes upon modern governments a new duty toward their citizens—the duty, namely, of protecting them from contagious or infectious diseases. This protection has to be provided by means of inspection stations, quarantines and other methods proper to secure the isolation of infected persons.



The diseases against which protection is most to be desired are cholera, smallpox, leprosy and yellow fever; and these diseases come in at the coast on vessels which are sailing under national authority and regulation. It is impossible to see how an effective control can be exercised over them except by the national government. Now that our government has driven Spain out from its West Indian possessions, and has assumed possession of Porto Rico and temporary control of Cuba, an opportunity is afforded of organizing this department and putting it upon a much more effective footing than would have been possible before. The island of Cuba has been the great source of yellow fever infection, and we now have, temporarily at least, the opportunity of ridding ourselves of this source of danger and dread. At the same time Congress can reconstruct what is now called the Marine Hospital Service, and render it, under some other name, a thoroughly effective agent for the protection of the people of the United States from imported preventable diseases. An effective bureau once established would undoubtedly find new opportunities of usefulness to the people. The preservation of the public health against the invasion of preventable disease is really one of the great interests of the American people, health and the protection of life to the normal period being infinitely precious to the individual and desirable alike for the happiness and the productiveness of the whole people. Indeed, the public health more directly concerns the public happiness than does agriculture, mining, trade or any other of the national activities. The present expenditure of the government for the Marine Hospital Service has been about \$650,000 a year, on the average for the five years 1893 to 1897. This budget ought to be greatly increased. It would be wholly reasonable for the government to spend as

much on behalf of the public health as it costs to keep three battleships in commission for a year in time of peace, say, one million of dollars.

The Life-Saving Service of the United States deserves to be greatly enlarged. The seacoast of the United States is of great extent, even if we do not include the deep indentations of a coast like that of Maine. On June 30, 1895, the number of life-saving stations was only 251, and of these 251 stations 53 were on the Great Lakes, 1 on the Ohio river and 13 on the Pacific coast. The mere mention of these figures demonstrates at once the inadequacy of the number of stations. The men employed must possess skill in surf-work and in the use of the various appliances for life-saving, and must be also men of unquestionable courage and good judgment. They are exposed in their routine of duty to many hardships and dangers. They struggle with wind and cold on the shore, and with some of the most formidable dangers of the sea. They must patrol beaches or rock-bound shores in the worst weather, and must be always ready for prompt service by night and by day. They need all the martial virtues, and these virtues are displayed not in killing and wounding, but in rescuing from death and injury. Shall we not all agree that this noble service should not be limited in its scope by any pecuniary consideration, but only by the probability of rendering service?

The Department of Agriculture is of comparatively recent creation, dating from 1893. The proper objects of the department are the discovery, study and development of the agricultural resources of the United States. It is primarily a scientific and technical department. Its main work is not done in Washington, but at scattered stations all over the country. Thus, there are outside of Washington 154 observing



stations and 152 signal stations of the Weather Bureau. There are also 152 meat-inspection stations in different towns and cities of the country, 21 quarantine stations for imported cattle, 9 stations for inspecting exported stock and 19 for inspecting stock for Texas fever. The division of statistics affords a measure of protection against combination and extortion in buying and selling the products of agriculture. When we consider the large proportion of our population engaged in industries which this department serves, and the importance of these industries to our national budget, may we not reasonably be surprised that the department is crippled by the parsimony of Congress with regard to salaries? On account of the low salaries authorized for scientific and technical services, the department is constantly losing some of its ablest and best workers. Apart from the Weather Bureau, which is now one of its divisions, the cost of the Department of Agriculture during the financial year 1896-97 was rather more than two millions of dollars—about the cost of one day of the war with Spain.

Next to agriculture in importance to the country comes the mining of coal and the metallic ores. The mineral wealth of the United States, including coal, is immeasurable, and there lie the foundations of all our manufacturing industries, and of the household comfort with which our population is so greatly blessed. One would naturally have supposed that the government of the United States would have been inclined to spend liberally on the discovery and investigation of our mineral resources, but such has not been the history of the Geological Survey of the United States. The expenditure upon it has never been generous, and has often been parsimonious. For the average of the five years 1893-97 the expenditures of the government on the Geological Survey and the issue of geological

maps was about \$450,000 a year, or less than the cost of six hours' war with Spain during the last four months.

The Weather Bureau of the United States, on which the nation spends less than a million dollars a year, contributes greatly to the comfort and health of the people and to the protection of their property, yet its number of stations for weather observation is manifestly insufficient, and the number of places at which warnings are conspicuously given is also insufficient. In the year ending June 30, 1897, that is, before the war, the country spent twice as much on mere repairs of naval vessels as it did on the Weather Bureau.

The Coast and Geodetic Survey of the United States has often been crippled in its work by lack of steady, timely and adequate appropriations. Its annual cost for the five years 1893-97 averaged \$418,000, or only a little over what it cost to maintain in commission the armored cruiser New York for the year 1897.

A new department of our government ought to be at once organized to secure the permanent protection and utilization of the forests on the national domain. The experience of other nations has already demonstrated that well-managed national forest reserves not only pay their expenses, but yield a revenue. The objects of such forest administration are of the utmost importance to a mining and farming population, being briefly, to ensure a permanent supply of timber, to protect the water-supply in agricultural regions adjacent to the forests, to prevent floods and to store water which in arid and semi-arid regions can subsequently be utilized for irrigation. The efforts thus far made to protect the national property in forests have not been successful, the greatest destruction being wrought, first, by fire, and secondly, by pasturage, but much harm being done by simple stealing of the forest product in districts where

there is no adequate policing of the reservations. In arid or semi-arid regions re-foresting, when once the original timber has been removed, is extremely difficult or in many cases impossible. Anyone who has traveled through the comparatively treeless countries around the Mediterranean, such as Spain, Sicily, Greece, northern Africa, and large portions of Italy, must fervently pray that our own country may be preserved from so dismal a fate. A good forest administration would soon come to support itself; but it should be organized in the interest of the whole country, no matter what it may cost. The estimate of the cost of the organization, as made by the Forestry Commission of the Academy, was two hundred and fifty thousand dollars a year for the first five years. This is about the annual cost of the maintenance of the protected cruiser *San Francisco*.

The government has carried on for many years past an inquiry into the habits, feeding grounds and modes of breeding and migration of the fish which make an important part of human food, and inhabit the western Atlantic and the eastern Pacific, the Great Lakes and the rivers and brooks of the continent. It is obvious that no power but that of the general government can carry on effectively a research of this magnitude, covering such enormous areas and dealing with such a variety of creatures, and it is obvious that such researches require expensive outfit, long time and highly-trained observers. Now, in this great enterprise the expenditures of the government during the five years 1893-97 have been \$360,000 a year, which is less than the annual cost of maintaining one of our battleships.

One other mode of beneficent expenditure the United States government has maintained for a generation, namely, the annual appropriation of money for certain colleges of agriculture and mechanic arts, which

were founded under the Act of 1862. In aid of these colleges the government appropriated in 1897 a million of dollars. Can any one of us see with satisfaction our government spend as little on the annual support of education in agriculture and the mechanic arts throughout the country as on the annual maintenance of three battleships in time of peace?

In instituting these comparisons between military and naval expenditure, on the one hand, and expenditure for purely beneficent objects, such as the advancement of science, the development of technical skill, the saving of life, the improvement of industries, and the support of education, on the other, I have no intention of even suggesting that the expenditures on military and naval preparation should be diminished, much less stopped, as Charles Sumner proposed. As war becomes more and more a matter of science—chemical, physical, biological and fiscal—and of highly-trained skill on the part of all who direct or operate the complicated machinery of war, it is manifest that it is the duty of the United States to build and maintain the most perfect instruments and appliances of war that the utmost skill of our engineers and mechanics can produce, and to keep in training adequate bodies of men to use effectively this elaborate machinery. But is it not equally clear that the nation which can afford to make this expenditure can afford to make much freer expenditures than our nation has ever made on the wholly beneficent agencies of the government, which save life, increase food and ore production, avert evils, facilitate transportation, promote industries and commerce, and foster education.

After everything possible has been said in favor of martial virtues and achievements, whenever our people really take up the question how best to win glory, honor and love for free institutions in general,

and the American Republic in particular, whether in our own eyes or in the eyes of other nations and later times, they will come to the conclusion that more glory, honor and love are to be won by national justice, sincerity, patience in failure and generosity in success than by national impatience, combativeness and successful self-seeking—and glory, honor and love more by as much as the virtues and ideals of civilized man excel those of barbarous men.

*A HALF-CENTURY OF EVOLUTION, WITH SPECIAL REFERENCE TO THE EFFECTS OF GEOLOGICAL CHANGES ON ANIMAL LIFE\* (II).*

THE APPALACHIAN REVOLUTION AND ITS BIOLOGICAL RESULTS.

UNLESS we except the great changes in physical geography which took place at the end of the Tertiary period, when the mountain chains of each continent assumed the proportions we now see, the Appalachian revolution, or the mountain-building and continent-making at the close of the Paleozoic age, was the most extensive and biologically notable event in geological history. In its effect on life, whether indirect or direct, it was of vastly greater significance than any period since, for contemporaneous with and as a consequence of this revolution was the incoming of the new types of higher or terrestrial vertebrates. Through the researches, now so familiar, in the field and study of the two Rogerses, of Dana and of Hall, we know that all through the Paleozoic era at least some 30,000 to 40,000 feet of shoal water sediments, both marine and fresh-water, derived from the erosion of neighboring lands, were accumulated in a geosynclinal trough over the present site of the range extending from near the mouth of the St. Lawrence to northern Georgia.

\* Address of the Vice-President before Section F—Zoology—of the American Association for the Advancement of Science, August, 1898; continued from SCIENCE, August 27th.

At the end of the era ensued a series of movements of the earth's crust resulting from the weight of this vast accumulation, which in a geologically brief period sank in, dislocated and crushed the sides of the trough, and folded the strata into great close parallel folds, besides inducing more or less metamorphism. These folds rising from a plateau formed mountain ranges perhaps as high as the Sierra Nevada or Andean Cordillera of the present day. The plateau emerged above the surface of the Paleozoic ocean, and was carved and eroded into mountain peaks, separated by valleys of erosion, the rivers of the Appalachian drainage-system cutting their channels across the mountain ranges.

But this process of mountain-building and erosion was not confined to the end of the Paleozoic era. Willis\* has shown that there were several successive cycles of denudation, covering a period extending from the end of the Paleozoic era to the present time. And it is the fact of these successive cycles of denudation both on the Atlantic and Pacific slopes of our continent that is of high significance to the zoologist from the obvious bearings of these revolutions on the production of variations. Indeed, it is these phenomena which have suggested the subject of this address.

We can imagine that this great plateau, in the beginning of the Mesozoic era, with its lofty mountain ranges and peaks rising from the shores of the Atlantic, presented different climatic zones, from tropical lowlands, with their vast swamps, to temperate uplands, stretching up perhaps to alpine summits, with possibly glaciers of limited extent filling the upper parts of the mountain valleys. New Zealand at the present day has a subtropical belt of tree ferns, while the mountains bear glaciers on their summits; and in Mexico, only about

\* National Geographic Magazine, 1889, Vol. I., pp. 291-300.



20° from the tropics, rising above the tropical belt, is the temperate plateau, and farther up the subalpine snow-clad summits of Popocatepetl, Orizaba and other lofty peaks. So in the Appalachians of the Paleozoic the cryptogamous forests and their animal life may have been confined to the coastal plains and lowlands, while on the higher, cooler levels may have existed a different assemblage of life; and it is not beyond the reach of possibility that a scanty subalpine flora peopled the cooler summits.

But the unceasing process of atmospheric erosion and river action continued through the Jurassic, which was, as stated by Scott, in his *Introduction to Geology*, 'a time of great denudation, when the high ranges of the Appalachian mountains were much wasted away, and the newly upheaved, tilted and faulted beds of the Trias were deeply eroded.' At about the time of the opening of the Cretaceous the range was reduced to a peneplain (the Cretaceous peneplain), with only vestiges of once lofty mountains; the scenic features roughly recalling those of North Carolina and New England at present, although more subdued and featureless, more like the Kittatinny peneplain of the Piedmont district at the eastern base of the Blue Ridge to-day as contrasted with the present mountain region of Pennsylvania and New Jersey. There were also extensive changes in the interior. What was the Colorado island was added to the mainland, and a great Mediterranean sea extended from the Uinta mountains of southeastern Wyoming to New Mexico and Arizona, and stretched from the Colorado peninsula westward to Utah. In the upper Jurassic as the result of a depression a gulf was formed over northern Utah, Wyoming and southern Montana (Scott).

The formation of this Cretaceous peneplain was succeeded by a re-elevation, and

the surface which is now Virginia was gradually raised to a height of 1,400 feet, and again the sluggish rivers of the Cretaceous times were revived, cutting through the harder strata forming the walls of the longitudinal valleys and, widening into broad estuaries, emptied into the Atlantic.

In the Eocene Tertiary, as Willis tells us: "The swelling of the Appalachian dome began again. It rose 200 feet in New Jersey, 600 feet in Pennsylvania, 1,700 feet in southern Virginia and thence southward sloped to the Gulf of Mexico." In consequence of the renewed elevation the streams were revived; and Willis adds: "Once more falling swiftly they have sawed, and are sawing, their channels down, and are preparing for the development of a future base-level."\*

We can in imagination see, as the result of these widespread physical changes, inducing as they must have done the formation of separate basins or areas enclosed by mountain ranges, with different climates and zones on land, however uniform might have been the general temperature of the world at that time and the other physical conditions of the sea—we can imagine the profound and deep-seated influence thus exerted on the life-forms peopling the uneven surface of the land.

The vegetation of the lowlands was rich and luxuriant, as the Triassic (Newark), coal deposits near Richmond testify, and, while the uplands and hills were probably clad with dense forests of conifers, on the dryer desert areas of the peneplain the trees may have been more scanty, like the scattered pines of the dryer elevated region of the Southwest and of the Great Basin at the present day. The distribution of the animal life must have corresponded; one assemblage, especially the amphibians, characterizing the hot and humid lowlands;

\*Quoted from Scott's *Introduction to Geology*, p. 342.



another the cooler uplands, while already perhaps a few forms became adapted to the more arid desert areas, as is the case now in Australia, which is in a sense a Mesozoic continent.

Similar subsidences and elevations changed the Jurassic map in Eurasia. This continent was already a land mass of great extent, and fresh-water lakes extended across Siberia, and in China were extensive swamps and submerged lands, now represented by coal fields. Afterwards in the middle Jura this continent subsided, and the Jurassic sea covered the greater part of Europe and Asia, this being, according to Neumayr, 'one of the greatest transgressions of the sea in all recorded geological history.' Subsidences and elevations resulted, it is supposed, in cutting off India from Eurasia, so that the strait or sea covered the site of the Himalayas, and India was possibly joined to Australia, the Malaysian peninsula forming the connecting link; or perhaps it stretched to the southwestward and was joined to South Africa. However this may be, it is sufficient for our present purpose that these vast changes in the relative position of land and sea were productive of a corresponding amount of variation and perhaps of immigration and consequent isolation. At all events, throughout the Jurassic seas as a whole there seemed to have been remarkable faunal differences. This led Neumayr, in which he is followed by Kayser,\* to conceive that there were already in Jurassic times climatic zones corresponding to the boreal, polar, north and south temperate and tropical zones of the present day. If, however, with Scott, we reject this view and substitute for it the supposition that 'the marked faunal differences are due to varying facies, depth of water, character of bottom, etc., and even more to the partly

isolated sea-basins and the changing connections which were established between them,' it is of nearly the same import to the geological biologist, for these varying conditions of the Jurassic ocean bottom could not have been without their influence in causing variation, modification and adaptation to this or that set of conditions of existence.

Turning now to the effects of the Appalachian revolution on the life of that time we see that the biological results were, in the main, in conformity with the geological changes. During the Carboniferous period vertebrates with limbs and lungs appeared, *i. e.*, the labyrinthodonts or Stegocephala. They were, compared with the other orders of their class, the most composite and highly organized of the Amphibia.

Throughout the long period of comparative geological quiet, those long ages of preparation which ended in the crisis or cataclysm which closed the Paleozoic, the amphibian type was slowly being evolved in the swamps and bayous of the lowlands of the Devonian, whose vegetation so nearly anticipated that of the Carboniferous from some Devonian\* or late Silurian ganoids, from which diverged on the one hand Dip-terus and the colossal lung-fish (*Dinichthys* and *Titanichthys*, of the Devonian, and perhaps on the other the labyrinthodonts, which may have sprung from some crossopterygian fish like *Polypterus*, and whose pectoral and ventral fins became adapted for terrestrial locomotion. The type was evidently brought into being provoked by, and at the same time favored by, the great extent of low coastal swampy land and bodies of fresh water which bordered the Atlantic seaboard from the Silurian time on.

How the amphibian type arose from the ganoid stock is a matter of conjecture. It

\*Text-book of Comparative Geology, translated and edited by Philip Lake, p. 270, 271.

\* Certain footprints recently discovered in the upper Devonian show that the type had become established, at least vertebrates with legs and toes.

may, however, be surmised that certain of the lung-fishes or forms like them, adapted for breathing the air direct when out of the water in the dry season, instead of remaining in their mud cells waiting for the rains to fill the lakes or swell the rivers, attempted, like the Anabas, or climbing fish, to migrate in schools overland; or, like that fish, which is said to have become "so thoroughly a land animal that it is drowned if immersed in water," it may have become confined to the land, and, losing its gills, used its lungs only. As a final result of its efforts to walk over the damp soil and mud of swampy regions the unaxial fins may have developed, through the strains and pressures of supporting the clumsy body, into props with several leverage systems; the basalial, instead of remaining in one plane as in a fish's fin, spreading out and becoming digits to support the weight and steady the body while walking. This process was not confined to one or to a few individuals, but, as Lamarck insists in the cases he mentions, it affected all the individuals over a large area. Those individuals with incipient limbs became erased or swamped, and we find no trace of them in the strata yet examined.

Thus far, indeed, Paleontology is silent† as to the mode of origin of the amphibian limb, as it is concerning the origin of arthropod limbs from the parapodia of annelids. Unfortunately, and this is still a weak point in the evolution theory, nowhere do we find,

\*Parker and Haswell's Text-book of Zoology, Vol. II., p. 220.

† Paleontology is also equally silent as to the origin of plesiosaurs and ichthyosaurs from their terrestrial digitigrade forbears, though in Archæopteryx we have an unusually suggestive combination of reptilian and avian features. Certain Theriodontia point with considerable certainty to the incoming of mammals, such as the Echinidna and duckbill, but as to the steps which led to the origin of the brachiopods, echinoderms, trilobites, of Sirenians and of whales paleontology affords no indications.

unless we except the Archæopteryx, clear examples of any intermediate forms between one class and another; each species as far as its fossil remains indicate seems adapted to its environment.

There are numerous cases of vestigial structures, but no rudimentary ones showing distinct progressive steps in a change of function. Hence arises the very reasonable view held by some that nature may make leaps, and that new adaptations or organs may be suddenly produced. No unadapted plant or animal as an entire organism has ever been observed either among fossils or existing species. Man has some seventy vestigial structures, but his body as a whole, notwithstanding the disadvantages of certain useless vestiges, is in adaptation to his physical and mental needs.

While the true Carboniferous labyrinthodonts were few and generalized, with gills and four legs; already in the Permian, where we meet with some thirty forms in the Ohio beds alone, and about as many in Bohemia, a great modification and specialization had taken place. Forms like Peleon and Branchiosaurus had gills and four legs; others were like our lizards, as in Keraterpeton; Dendrerpeton and Hylonomus of Nova Scotia were more lizard-like and with scales; others perhaps swam by means of paddles as in Archegosaurus; others, like the 'Congo snake,' were snake-like with small weak legs, as Cestocephalus; some had gills but no legs, as in Dolichosoma, while in others the limbless body was snake-like and scarcely larger than earth worms, as in Phlegethontia of the Ohio and Ophiderpeton of the Bohemian coal measures.

Already, then, in Permian times the stegocephalous type showed signs of long occupation, old age and degeneration. The process of degeneration and reduction in and loss of limbs may have been initiated as far back as the closing centuries of the Devonian.

The effect of the Appalachian revolution and corresponding physical changes in Europe was by no means disastrous to the Stegocephala, for those of the Liassic, where the conditions must have been more formidable to terrestrial vertebrate life, were abundant, and in some cases at least colossal in size. Whether the salamanders, cœcilians, sirens and Amphiuma of present times are persistent types, survivors of Carboniferous times, or whether the process of modification has been accomplished a second time within the limits of the same class, is perhaps a matter for discussion.

Besides the introduction and elaboration of the air-breathing, four-footed labyrinthodonts, the sloughs and sluggish streams were alive with Naiadites and its allies, forerunners of the Unionidæ, and with them lived shelled Phyllopod, Estheria having already appeared in the Devonian, Leaila appearing in the Carboniferous; and also the larvæ of aquatic net-veined insects, fragments of the imagines of which were detected by Hartt at St. John, New Brunswick.

The coal-bearing strata are largely fresh-water beds of fine shale and well calculated to preserve the hard parts of delicate animals, but on general grounds it is evident that the great extent of low lands with extensive bodies of fresh water, communicating with the shallow sea, was most favorable to the development and differentiation of terrestrial life. Though fresh-water and land shells (pulmonates) appeared in the Devonian, they were apparently more abundant in the coal period. Especially rapid was the incoming of the arthropods; both diplopods, some of them very remarkable forms, and chilopods lived sheltered under the bark of colossal lycopods; with them were associated scorpions, harvestmen and spiders. The great profusion of net-veined insects discovered at Commeny, France, shows that this was the age of the

lower more generalized or heterometabolous insects, such as cockroaches and other Orthoptera, of Eugereon, may-flies and possibly dragon-flies, etc., our wingless stick-insects being then represented by winged ancestors. At this time also began the existence of insects with a complete metamorphosis, as traces of true Neuroptera and the elytra of a beetle have been detected in Europe. But thus far no relics of flowers or of the insects which visit them have been discovered in Carboniferous times, not even in the Permian, so that the origin of insects with a complete metamorphosis, such as moths, ants and flies, may be attributed to the new order of things, geographical and biological, immediately following the Appalachian revolution.

We do not wish to be understood as implying that the origin of new orders and classes is directly due to geological crises or cataclysms themselves.\* On the contrary, the initial steps seem to have been taken as the result of the gradual extension of the land masses and the opening up of new areas; it was the period of long preparation, with long-continued oscillations, the slowly induced changes resulting from the reduction of the mountainous slopes to peninsulas, which were most favorable to the

\* I find that Wood has already expressed the same idea more fully, as follows: "Both in the palæozoic and secondary periods, therefore, the complete changes in the fauna which marked their termination do not appear to have been immediate upon the changes of the geographical alignment, but to have required the lapse of an epoch for their fulfilment; and the completeness of that change is perhaps not less the indirect result of the altered alignment, by the formation of continents where seas had been, and the opening out of new seas for the habitation of marine animals, thereby causing a gap in the geological records so far as they have been hitherto discovered, than the direct result of the changed conditions to which the inhabitants of the seas, and even those of the land, came to be subject on account of the entire change in the alignment of the land over the globe." (*Phil. Mag.*, XXIII, 1862, p. 281.)



gradual modification of forms resulting in new types, the gradual process of extinction of useless and senile forms, and the modification and renewal of those which became adapted to the new geographical conditions.

It should be borne in mind that this extension of the low coasts of the continents began in Ordovician times, but the remarkable expansion of our continent after the Appalachian revolution, rather than the upheaval of the plateau itself, so favorably affected plant and animal life that at the dawn of the Mesozoic a great acceleration in the process of type-building was witnessed. Moreover, it seems evident that the variation which took place at this epoch was by no means fortuitous, but determined along definite lines caused by the definite expansion of the continents and their resultant topography.

We have seen that, as a result of the folding and upheaval of the Appalachians, there may have been at the beginning of Triassic time, in addition to the tropical lowlands, a somewhat cooler upland zone, and possibly even snow-clad mountain peaks, with glaciers descending their sides, as we may now witness in New Zealand.

Already on Permian soil reptiles were not infrequent. They were generalized composite forms comprising the Proganosauria, the forerunners of the Hatteria of New Zealand, and the Theriodontia, from which the mammals are now supposed to have been derived. They disappeared at the end of the Triassic, together with the labyrinthodonts, from which the reptiles are thought to have originated. These reptiles having scaly bodies and claws, their habits must have been like those of the lizards of to-day, and they were adapted for hotter and dryer, perhaps more elevated, areas than the stegocephalous amphibians; and these conditions were fulfilled in Triassic and Jurassic times, when the reptilian orders multiplied, all the orders of the class

having been differentiated in the Mesozoic era, if not before.

The geographical features throughout the Mesozoic were these: more or less dry and broad plains, vast fresh-water lakes, uplands clad with coniferous forests afterwards to be replaced by forests of deciduous trees; flower-strewn plains overgrown with waving grasses, and jungles with rank growths of bamboo. We can, without going into detail, well imagine that the geographical features of the Mesozoic continents were such as to provoke the appearance of the higher classes of vertebrates. As the land rose higher and the low, swampy coastal areas became more limited, this would tend to restrict the habitat of the stegocephalous amphibians; with a slightly more elevated and dryer coast the incoming and expansion of reptilian life were fostered; with still higher plains and hills, besides the increasing abundance of flowers and other seed-bearing plants and of the insects which visit them, existence for birds became possible, and with them that of a few scattered mammals of small size and generalized structure, with similar insectivorous habits.

During the age of reptiles, when they swarmed in every jungle, throughout the forests and over the plains, competition rose so high that some of them were forced to take flight, and bat-like, provided with membranous wings, the pterodactyls lived in a medium before untried by any vertebrate, and finally there appeared in the Ornithostoma of the Cretaceous a colossal flying reptile, its wings spreading twice as much as any known bird, with a head four feet in length; its long toothless jaws closing on swarms of insects or perhaps small fry of its own type. But the experiment in point of numbers or capacity for extended flight did not succeed. Another type assayed the problem with better success. There appeared feathered and eventually toothless vertebrates with the fore



extremities converted into pinions and the hinder ones retaining the raptorial reptilian form better adapted for aerial life. They eked out a by no means precarious existence on flying insects and seeds, as well as on the life in the soil or by the seaside, and rapidly replaced certain older reptilian types. The class of birds has become about four times as numerous as the reptiles, and outnumbers the mammals nearly six times.

We may now review the zoological changes which took place at the time including the end of the Paleozoic and the opening of the Mesozoic. There was an extinction of the Tetracoralla and their replacement by corals with septa arranged in sixes; an extinction of cystidian and blastoid crinoids, the dying out of old-fashioned crinoids and echinoids (Palæocrinoidea and Palæechinoidea), followed by the rise of their more modern specialized successors. As rapidly as the brachiopods became diminished in numbers their place at the sea-bottom was taken by the more active and in some cases predatory bivalve and univalve molluscs. As the trilobites became extinct their place in part was filled by their probable descendants, the Limuli, which had already begun to appear, the earliest types being *Neolimulus*, *Exapinurus* and other forms of the Silurian, and *Protolimulus* of the Devonian. The Limuli of the Carboniferous, some with short (*Prestwichia* and *Euproops*) and others with long tail-spines (*Belinurus*), suggest long possession of the soil and consequent variation and differentiation.

The Eurypterida shared the fate of the trilobites, and while there was a thorough weeding out of the more typical ganoids, leaving an impoverished assemblage to live on through after ages, that singular primitive vertebrate group, the Ostracodermi, was wholly obliterated.

On the other hand, with the incoming of

a new order of vegetation, a great outgrowth of winged insects, the representatives of the orders of Lepidoptera and Hymenoptera, now so numerous in species, began their existence.

By the close of the Appalachian revolution probably all the orders of insects had originated, unless we except the most modified of all, the Diptera, whose remains have not been detected below the Lias. With but little doubt, however, the eight orders of holometabolous insects diverged in the Permian, if not near the close of the Carboniferous, from some protoneuropter; the progress in the differentiation of genera and families becoming rapid either during the Jurassic or directly after the lower Cretaceous, or as soon as grasses and deciduous trees became in any way abundant.

Very soon, too, after the close of the revolution the ancestral birds and mammals diverged from the reptiles, and of the latter the turtles, plesiosaurs, ichthyosaurs, crocodiles and dinosaurians, and soon after the pterodactyles, came into existence.

As a result of this revolution the moluscan type was profoundly affected, as at the opening of the Triassic siphoniate Pelecypoda, opisthobranchiate Gastropoda and cuttles or belemnites appeared. While a few *Orthoceratites* lingered on after the revolution, the *Ammonites* blossomed out in an astonishing variety of specific and generic forms.

In summing up the grand results of the Appalachian revolution and of the times immediately succeeding, we should not lose sight of the fact that the changes in the earth's population were due no less to biological than geological and topographical factors. This process of extinction was favored and hastened by the incoming of more specialized forms, many of them being carnivorous and destructive, as, for example, nearly all fishes and reptiles live on other animals. The

struggle for existence between those which became inadapted and useless in the new order of things went on more actively than at present. The process of extinction of the higher, more composite amphibians (the labyrinthodonts) was largely completed by the multitude of theromorphs and dinosaurs which overcame the colossal Cheirotherium, Mastodonsaurus and their allies.\*

During the centuries of the Trias the lowlands became crowded, and the reptilian life was forced in some cases to gain a livelihood from the sea, for at this time was effected the change from small terrestrial reptiles like Nothosaurus to the colossal pleiosauers and ichthyosauers, in which digitate limbs were converted into paddles, and the ocean, before this time uninhabited by animals larger than ammonites, cuttles and sharks, began to swarm with colossal vertebrates, the increased volume of their new and untried habitat resulting in a tendency to a corresponding increase in weight, just as whales which possibly evolved from some land carnivora in the early Tertiary waxed great in bulk, the increase in size, perhaps, having been due to the great volume of their habitat, the ocean.

Nothing so well illustrates the advantage to an incipient type as entering a previously uninhabited topographical area, or a new medium, such as the air. In the case of the pterodactyles, the first vertebrates to solve

\*After writing the above lines I find the same view expressed in Woodworth's Base-leveling and Organic Evolution. He remarks: "The exact cause of their decline is probably to be sought in the development of the more powerful reptilia" (p. 225). Regarding the circumstances favorable to reptilian life, he also states: "In the development of the peneplain from the high relief of the Permian and again at the close of the Jura Trias the widening out of the lowland, with plains and jungles, near tide-level, followed by depression of the land, must have highly favored the water-loving reptilia. It is to these geographical circumstances, I think, that we must look for our explanation of the remarkable history of this class in Mesozoic times" (p. 226).

the problem of aërial flight, originating and prospering in the early Mesozoic, they held their own through the Cretaceous, where at their decline they became, as in Ornithostoma, colossal and toothless. We can imagine that the demise of this type was assisted in two ways; those with a feebler flight succumbed to the agile, tree-climbing dinosaurs; while the avian type, waxing stronger in numbers and power of flight and exceeding in intelligence, exhausted the food supply of volant insects, and drove their clumsier reptilian cousins to the wall, fairly starving them out, just as at the present day the birds give the bats scarcely a *raison d'être*.

### 3. THE PACIFIC COAST REVOLUTIONS.

It has long been known that there are a greater number of insect faunæ on the Pacific coast and greater variation of species, with more local varieties, than east of the Mississippi river. It has also been shown by Gilbert and Evermann, as well as by Eigenmann, to apply to the fishes of the Columbia and Frazer river basins. "Nowhere else in North America," says the latter, "do we find, within a limited region, such extensive variations among fresh-water fishes as on the Pacific slope." He also points out the noteworthy fact that the fauna is new as compared with the Atlantic slope fauna, and 'has not yet reached a stage of stable equilibrium.' As previously shown by Gilbert and Evermann, "each locality has a variety which, in the aggregate, is different from the variety of every other locality;" and he adds: "The climatic, altitudinal and geological differences in the different streams, and even in the length of the same streams, are very great on the Pacific slope."

It is evident that the variations are primarily due to the broken nature of the Pacific coast region, and to the isolation of the animals in distinct basins more or less

surrounded by high mountain barriers, with different zones of temperature and varying degrees of humidity.

As brought out by the labors of Le Conte, Diller and Lindgren, the Sierra Nevada region has undergone cycles of denudation, and these changes, occurring later than those of the Appalachian region, have doubtless had much to do with the present diversified and variable fauna. The latest writer, N. F. Drake,\* states that the western slope of the Sierra Nevada "was probably once a region worn down almost to base-level or to a peneplain. By the uplift of the mountains a great fault was developed along the eastern face and the whole Sierra crust-block tilted to the westward. The streams quickened by the uplift again set to work on the peneplain and carried it to its present condition."

Le Conte † states that the Sierra Nevada was upheaved at the end of the Jurassic period. This corresponded to the Appalachian revolution which occurred at the end of the Paleozoic era.

"But during the long ages of the Cretaceous and Tertiary this range was cut down to very moderate height. \* \* \* The rivers by long work had finally reached their base-levels and rested. The scenery had assumed all the features of an old topography, with its gently flowing curves \* \* \* At the end of the Tertiary came the great lava streams running down the river channels and displacing the rivers; the heaving-up of the Sierra crust-block on its eastern side, forming the great fault-cliff there and transferring the crest to the extreme eastern margin; the great increase of the western slope and the consequent rejuvenescence of the vital energy of the rivers; the consequent down-cutting of these to form the present deep canyons and

the resulting wild, almost savage, scenery of these mountains."

This view is further carried out by J. S. Diller, from his studies of the northern part of the Sierra Nevada, including the borders of the Sacramento valley and the Klamath Mountains. He shows that northern California, during the earlier portion of the auriferous gravel period, was by long continued degradation worn down to base-level conditions. "The mountain ranges," he says, "were low, and the scenery was everywhere characterized by gently flowing slopes." \* \* \*

"The topographic revolution consisted in the development out of such conditions of the conspicuous mountain ranges of to-day. The northern end of the Sierra Nevada has since been raised at least 4,000 feet, and possibly as much as 7,000 feet, and a fault of over 3,000 feet developed along the eastern face of that portion of the range."\*

According to Lindgren the Sierra Nevada was eroded to, or almost to, a peneplain during Cretaceous times, and the mountains elevated in a later Cretaceous period were worn down during Tertiary times merely to a gentle topography.

The other post-Cretaceous changes of this vast region are thus summarized by Scott from the results of Pacific coast geologists. In the Eocene a long narrow bay occupied the great valley of California, extending northward into Oregon and Washington. At the end of the Eocene or early in the Miocene an elevation in California shifted the shore line far to the west. In the Miocene the Coast Range formed a chain of reefs and islands, and at the close an upturning and elevation of the mountain range took place, though it became higher afterwards. The Coast Range sank again early in the Pliocene and the San Francisco peninsula was an area of subsidence and

\* The Topography of California. *Journ. of Geology*, V., Sept.-Oct., 1897, p. 563-578.

† *Bulletin Geol. Soc. Amer.*, II., pp. 327, 328.

\* 14th Ann. Rept. U. S. Geol. Survey, Part II., p. 433.



maximum deposition forming the thickest mass (58,000 feet) of Pliocene in North America. The mountains of British Columbia are believed to have been at a higher level than now, as it is supposed that Vancouver and Queen Charlotte Islands probably formed part of the mainland.

At or near the close of the Pliocene the Sierra Nevada increased in height by the tilting of the whole block westward. New river valleys, cut through the late basalt sheets of the Sierras, are much deeper than the older valleys excavated in Cretaceous and Tertiary times, owing to the greater height of the mountains and to the consequent greater fall of the streams. At this time the Wasatch Mountains and high plateaus of Utah and Arizona were again upraised, and the great mountain barrier of the St. Elias, in southeastern Alaska, was likewise thrown up. At this time also, or perhaps later, the mountains of British Columbia were probably raised still higher.\* It will be seen from this that the present topography of the western border of our continent including Central America and the Isthmus of Panama belongs to a new topographic era, and fully substantiates the view that the fauna of these regions is very recent compared with that of the Atlantic border, and that the number of nascent or incipient species is much greater.

ALPHEUS S. PACKARD.

BROWN UNIVERSITY.

(To be concluded.)

#### EARTHQUAKES.

COMMANDANT MONTESSUS DE BALLORE, of the French Army, is well known as an authority on earthquakes in general, and especially on the earthquakes of Central America, where he resided for a considerable time some dozen years ago. Besides his own observations he has discussed thousands of others, collected by himself

\* *Journal Geol.*, IV., pp. 882, 894, 897 and 898. (Quoted from Drake.)

or taken from the extended lists of Mallet (B. C. 1606 to A. D. 1850), Perrey, Fuchs, etc. All of the available material has been sifted and examined, and then discussed in a scientific fashion, to bring out whatever general laws may underlie the statistics.

A collection of some of M. Montéssus' pamphlets has lately come into my hands.\* They deserve an extended review, but, failing this, the following notes may be of interest.

The relations between the topography of a country—its topographic relief—and the frequency of its earthquakes has been deduced from 98,868 records of shocks at 6,789 centers distributed in 353 regions of the globe. The most general statements that can be made are as follows:

"Regions of great earthquake frequency lie near the greater lines of corrugation of the earth's crust."

"In any group of adjacent seismic regions the earthquake frequency is greatest in the regions of highest relief."

These very general laws may be put into more special forms that are directly proved by the statistics:

I. Mountainous regions are more unstable than plains.

II. Sea-coasts near oceans that rapidly deepen, especially such as are bordered by high mountains, are more unstable than the coasts of shallow seas, especially if such coasts have no mountains near them.

III. The shorter and steeper slopes of mountain chains are the more unstable.

\* Relations entre le relief et la sismicité, *Archives des Sciences Phys. et Nat.*, 1895; Le Japon sismique, *ibid.*, 1897; Les Etats-unis sismiques, *ibid.*, 1898; Les Indes Néerlandaises sismiques, *Nat. Tijd. der Kon. Nat. Ver. in Nederlandsch-Indie*, DL. LVI., 1896; Etude critique des lois de répartition saisonnière des séismes, *Mem. de la Soc. "Alzate"*, tomo IV.; Relation entre la fréquence des tremblements de terre et leur intensité, *Bull. d. Soc. Sismologica Ital.*, Vol. III.; La peninsula ibérica sísmica y sur colonias, *Ann. de la Soc. Española de Hist. Nat.*, tomo XXIII.; Seismic Phenomena of the British Empire, *Quar. Jour. Geol. Soc.*, Vol. LII., 1896.



IV. The unstable flank of a mountain chain is most unstable in its steepest parts.

V. The steeper sides of valleys are, likewise, the more unstable.

VI. When two mountain chains cross, making an angle of less than  $90^\circ$ , the area inside the exterior angle is the most unstable.

$$\frac{a}{b \times}$$

(The region  $a$  will have more shocks than the region  $b$ .)

VII. When a mountain chain ( $a$ ) has a buttress ( $b$ ) the flank opposite  $b$  is the more unstable ( $c$ ).

$$\frac{c}{|b}$$

VIII. Mountain masses are more unstable on their flanks than within the mass.

IX. Abrupt changes of slope are especially favorable to instability.

X. The highest parts of valleys are frequently more stable than those at the average level, and the lowest parts are generally more stable than those of average level.

XI. Narrow mountainous peninsulas are unstable.

XII. An isthmus in a sunken region is unstable.

XIII. Narrow straits are often the centers of earthquakes.

XIV. Regions of great earthquake frequency usually do not coincide with regions of many volcanoes; or, earthquakes and volcanic phenomena are, in general, independent of each other.

Several of these laws are well known; some of them would be announced by an expert even before seeing the data; but, on the other hand, some of them are genuine surprises. In their collected shape they constitute an important contribution to the subject. Law XIV. is not proved in the pamphlets cited by title, but the first half of it is well known to be true in very many regions of the globe, and the last half follows as a *statistical* consequence.

It is a very ancient opinion that earthquakes are decidedly more frequent at some seasons of the year than at others. Aristotle, for example, declared that the autumn and spring were seasons of frequent shocks, while summer and winter were seasons of few shocks. Perrey, Mallet and others have announced similar laws. From a discussion of 63,555 shocks in 309 regions of the globe M. de Montessus shows that, taking the whole earth together, shocks are equally probable at any season. This general law may not be true for certain special localities, but it is true for the whole earth.

In order to study earthquake statistics to advantage and to compare one region with another it is desirable to have some uniform method of expressing earthquake frequency numerically—of deducing the coefficient of earthquake frequency, as a mathematician might express it. M. Montessus forms such numbers in the following way: The region to be studied is divided into smaller areas. Each of these areas is chosen so as to be fairly homogeneous in physical characteristics, geographically, geologically, etc. The areas are now divided into as many small squares as there are earthquakes per year. The greater the frequency the greater the number of squares, of course. The side of one of these small squares is chosen as the coefficient of frequency,\* and the greater the number of shocks per year the smaller is this coefficient. There is something arbitrary in this process; but, at the same time, it leads to results of importance because, after all, it is only the *relative* earthquake frequency that is sought, not the absolute. Of two regions, which is most shaken and in what ratio? is the question to be solved.

In eastern Java, for example,  $S$  (the seismic number) is equal to 56 kilometres. That is, there is, on the average, one earthquake per year in each square of 56 kilometres on

\* M. Montessus calls it the 'sismicité.'

a side. In western Java  $S = 50$  km. There are more earthquakes in this region. It will not be without interest to quote a few of the author's conclusions expressed in this numerical form.

For Porto Rico,  $S = 2.3$  km., that is, there is one earthquake annually in each square of 2.3 km. (1.38 miles) on a side on the average.

For the island of Luzon,  $S = 2.8$  km.; for Manila,  $S = 3.0$  km.; for central Cuba,  $S = 41$  km.; for western Cuba,  $S = 128$  km.; for Hawaii,  $S = 37$  km. These numbers may be compared with others relating to the United States, as central California,  $S = 76$  km.; New England,  $S = 90$  km.; the Carolinas,  $S = 313$  km.; Michigan,  $S = 487$  km., or with Tokyo, Japan—one of the most disturbed portions of the globe—for which the number is 12 km. Manila and Porto Rico are far more disturbed than this.

Work of the kind here noticed is valuable in proportion to the care with which the data have been sifted, and to the impartiality of the investigator. It is believed that anyone who will examine the work of M. Montessus carefully will conclude that he has made a considerable step forward.

EDWARD S. HOLDEN.

STOCKBRIDGE, MASS.,  
August 15, 1898.

#### ZOOLOGICAL NOTES.

MR. FRANK FINN, of the Indian Museum, Calcutta, has been making an extensive series of experiments with birds in regard to the value of the so-called warning colors of butterflies. These experiments, which are recorded at length in the *Journal* of the Asiatic Society, are extremely valuable from the fact that while it has been assumed that insects nauseous to man are equally nauseous to birds this has not been sufficiently well proved. In fact, it has been shown by

the investigations of the Department of Agriculture that many of the (to us) vile-tasted Hemiptera are greedily devoured by birds. Definite information is also needed as to the extent to which birds actually eat butterflies. The experiments were mainly made with Babblers, *Crateropus*, and Bulbuls, *Otocamps*, although a few other species were used.

As a result of his experiments Mr. Finn concludes: "That there is a general appetite for butterflies among insectivorous birds, even though they are rarely seen when wild to attack them.

"That many, probably most, species dislike, if not intensely, at any rate in comparison with other butterflies, the 'warningly-colored' *Danainæ*, *Aeræa violæ*, *Delias eu charis* and *Papilio aristolochiæ*, of these the last being the most distasteful, and the *Danainæ* the least so.

"That the mimics of these are at any rate relatively palatable, and that the mimicry is commonly effectual under natural conditions. That each bird has to acquire separately its experience, and well remembers what it has learned."

That, therefore, on the whole the theory of Wallace and Bates is supported by the facts and Professor Poulton's suggestion that animals may be forced by hunger to eat unpalatable forms is also more than confirmed.

F. A. LUCAS.

#### CURRENT NOTES ON ANTHROPOLOGY.

##### INDETERMINATE FORMS OF CHIPPED STONES.

THERE is a large class of objects which constantly puzzle the antiquary. These are flaked or chipped stones simulating the forms of art effects, yet not positively indicating the work of man.

In a handsome and abundantly illustrated volume of 70 pages M. A. Thieulen publishes a paper read before the Anthropological Society of Paris on a collection of

these objects from the drift of France. He claims that they represent the most common instruments of palæolithic man. They very rarely show distinct secondary chipping or the bulb of percussion; for which reasons his arguments do not seem to have convinced the Society; yet some of the specimens he figures might well pass as human handiwork. (*Les véritables Instruments usuels de l'âge de la Pierre*. Paris, Imprimerie Larousse, 1897.)

#### WAS BUDDHA A MONGOLIAN?

FERGUSSON and others have claimed that the celebrated founder of Buddhism was of Mongolian origin. With an astonishing ignorance of ethnic traits, Fergusson supported this by the bold assertion that in India Buddha is always represented with woolly hair!

Professor E. W. Hopkins, of Yale, in his 'Notes from India' in the last (19th) volume of the 'Journal of the American Oriental Society,' takes occasion to report on this point. Many ancient figures of Buddha have the hair gathered up in little spiral, conch-shaped curls. According to tradition Buddha had curly hair and wore it short. From an examination of many statues it was evidently wavy, but never woolly. In some instances it is colored red. The general evidence is that so far as hair was concerned he preserved the type of the white race, and was equally remote from the Mongolian and the Negro.

#### MEXICAN ANTIQUITIES.

PROFESSOR FREDERICK STARR is preparing a 'Manual of Mexican Archæology,' which is sure to be a complete and valuable work, and one much needed at this time.

He anticipates portions of it in Vol. VII. of the 'Proceedings of the Davenport Academy of Natural Sciences,' by an article on 'Notched Bones from Mexico,' in which he explains those described by Dr. Lumholtz to be musical instruments (as I also did in

SCIENCE, May 27). Another article is on a shell inscription from Tula. It shows a fragment of *Haliotis* shell with four Mayan characters engraved upon it. This leads him to what he calls the 'startling' conclusion that there were trade relations between Tula, at the time of its occupancy, and the Mayan districts. But that fact is well known from Sahagun's 'History'; and the Tula, some forty miles north of Mexico, was surely not Tula the Magnificent, where Quetzalcoatl ruled his million of warriors!

D. G. BRINTON.

UNIVERSITY OF PENNSYLVANIA.

#### NOTES ON INORGANIC CHEMISTRY.

THE place of helium and argon in the periodic system has already caused much discussion, and now, that several other elements of similar nature have been discovered, the conjectures as to what to do with the whole group will be forthcoming doubtless in great profusion. Happily the *mélange* known as the Group VIII. in Mendeléef's table offers a refuge equal to almost any emergency that may arise. One element might exist in this group with an atomic weight somewhere from 1 to 7, another 19 to 23, another or even three between 36 and 39, three more between 80 and 85, three more between 128 and 132, to say nothing of possibilities of higher atomic weight. It is even possible that three elements could exist in place of each of the first two. From their position in the table, nothing could be foretold as to the properties of elements filling these places, save perhaps that their character would be neither positive nor negative (*i. e.*, without chemical affinity?) and that their valence would be zero (*i. e.*, forming no compounds?). These new elements, as far as they have been described, do singularly fulfil these conditions, helium falling into the first place, neon the second, argon and metargon the third and krypton the fourth. It is,

however, too early for any serious study of the position of at least several of these elements, inasmuch as the question of even their existence is not settled. However, in a recent paper before the Royal Society, Sir William Crookes shows that helium, argon and krypton fall naturally into the periodic scheme of the elements as devised by him, which differs not very materially from that of Mendeléef. In a postscript to his paper printed in the *Chemical News*, Crookes shows that neon and metargon as far as described also fall naturally into his scheme.

THE boiling point of ozone was determined approximately by Olszewski a few years ago as about  $-106^{\circ}$ . More recently Professor L. Troost has made several very accurate determinations, which are described in the *Comptes Rendus*. The temperature at which the liquefied ozone boiled was determined by an iron-constantin couple, and was  $-119^{\circ}$ . This may then be considered the boiling point of ozone at atmospheric pressure.

It has long been hoped that a study of graphitic acid would lead to better knowledge of the structure of the carbon molecule in graphite. The greatest obstacle has been the difficulty of oxidizing the graphite to graphitic acid. Repeated treatments of graphite with nitric acid and potassium chlorate finally yield but a very small amount of the acid, even if explosions, which are very apt to occur, are successfully avoided. In the last number of the *Berichte* L. Staudenmaier describes a method which consists chiefly in treating graphite that has been partially oxidized by the old method, with a mixture of potassium permanganate and sulfuric acid. In this way the graphitic acid may be rapidly obtained in considerable quantities, and it is to be hoped that its study will now be prosecuted until light is thrown on the graphite molecule and possibly on allotropy in general.

THE question of whether the formula of potassium permanganate should be written  $\text{KMnO}_4$  or  $\text{K}_2\text{Mn}_2\text{O}_8$  has been in the opinion of many chemists unsettled, even though it was recognized that the salt was isomorphous with the perchlorate,  $\text{KClO}_4$ . Even now, in his periodic scheme, Crookes puts both fluorin and manganese into the same group with iron and the platinum metals. The last *Journal* of the Chemical Society (London) contains a research by J. Murray Crofts, of Emmanuel College, on the molecular weights of permanganates, perchlorates and periodates in solution. The salts used were those of potassium and sodium except in the case of the periodate, where the potassium alone was used. The freezing-point method was used, the solvent being Glauber's salt. In every case the molecular weight was that of the simpler formula, so that, as far as solution goes, the formulæ must be considered to be  $\text{KClO}_4$ ,  $\text{KIO}_4$  and  $\text{KMnO}_4$ .

J. L. H.

---

#### SCIENTIFIC NOTES AND NEWS.

##### BIOLOGICAL STATION OF THE UNIVERSITY OF INDIANA.

MR. A. C. YODER, of Vincennes, Ind., writes that the Indiana University Biological Station, situated at Vawter Park, Ind., closed its work of the summer on August 19th. The Station was organized in 1895 by Dr. Carl Eigenman, of Indiana University. There is a direct connection between the work done at the Station and at the University proper, credit being given at the one for work done at the other. The Station since organized has been located on Turkey Lake, in northern Indiana. Turkey Lake, about seven miles long and two miles wide, is the largest of the numerous fresh-water lakes found in northern Indiana and is two miles north of the divide, separating the St. Lawrence and Mississippi basins. An abundance of biological material can be had from the lakes on both sides of the divide, and thus are offered excellent opportunities for studying the varia-



tion of species and the influence of different environment. The session of 1898 consisted of two terms of five weeks each. Courses were offered in elementary geology, embryology, bacteriology and botany. Thirteen instructors and assistants were engaged.

The appended data show the success and growth of the Station :

In 1895 there were enrolled 19 students and 1 State represented.

In 1896 there were enrolled 32 students and 4 States represented.

In 1897 there were enrolled 68 students and 5 States represented.

In 1898 there were enrolled 105 students and 8 States represented.

Next year the Station will be in Winona Park, at Warsaw, Ind., eighteen miles from the present location. The Winona Park Association will erect the necessary buildings.

#### CHRISTMAS ISLAND.

In a recent issue of SCIENCE we reported the return of Mr. C. W. Andrews, of the geological department of the Natural History Museum, from his expedition to Christmas Island. The expedition started about fifteen months ago, and was sent out by Sir John Murray at his own expense. The flora and fauna of the island are believed to have been uninfluenced by man, and therefore the study of these, as well as of the geology of the island, was expected to yield valuable results. We learn from the *London Times* that the results of the expedition are likely to fulfil the highest expectations. Mr. Andrews pursued his labors under the greatest difficulty. The island is 1,200 feet high, but so densely covered with gigantic forest vegetation and bush that the members of the little colony on the shore have never been able to move a mile from home. The only available drinking water is supplied by a spring on the shore, and as the cliffs are lofty and precipitous it is difficult in the extreme to convey the water into the interior. This will give some idea of the difficulties which Mr. Andrews had to face in making his way over the island. As a matter of fact, with the help which he found available, his rate of progress was not more than two miles a day. The island, moreover, swarms with gi-

gantic land-crabs and rats, which, however interesting from a scientific point of view, are plagues to the explorer. Mr. Andrews had often to sleep out unprotected by a tent, and had to adapt himself as best he could to having his toes nipped by the formidable pincers of the crabs, and his body scampered over by hundreds of rats. The only chance of survival for animals in Christmas Island is their ability to climb trees and swing lianas, and both rats and crabs are as accomplished at this as monkeys in an African forest. Mr. Andrews has brought home ample collections of these and of the other animal life which abounds on the island, the insects being particularly rich. The flora of the island, also, is abundantly represented in Mr. Andrews's collections, as well as geology and other branches of science. To geologists especially the island is of great interest. The core of the island is volcanic, but originally a coral reef occupied the position. The original reef, or atoll, it is believed, now forms the cap or summit of the island, and at intervals downwards coral bands exist, which seem to indicate that the elevation must have been gradual and at considerable intervals. These are among some of the valuable results brought back by Mr. Andrews, and science owes a debt of gratitude to Sir John Murray for his liberal enterprise in equipping the expedition. Mr. Andrews will probably give some account of his work at the Bristol meeting of the British Association, and is expected to read a paper on the subject at the Royal Geographical Society's next session. He has brought home about 400 photographs.

#### GENERAL.

ALTHOUGH Columbus, Ohio, was chosen as the place of meeting of the American Association in 1899, the invitation from Philadelphia was declined with much regret. It was prepared with great care and presented with much cordiality, and it is to be hoped that Dr. Brinton and other Philadelphia members will renew the invitation next year.

THE Council of the American Association authorized last week the appointment of a committee 'to increase the efficiency of the Naval Observatory.' It consists of Professor Picker-

ing, President Mendenhall and Professor Woodward.

HEREAFTER the various Secretaries of the American Association are to be granted \$20 for hotel expenses, provided that during the meeting they reside at the headquarters. This seems to be an excellent plan, though it should also be conditional on their being in attendance throughout the meeting beginning on Saturday. The confusion that is likely to occur in the earlier programs is usually due to lack of preliminary meetings of the Secretaries.

THE plan of holding no general sessions daily of the whole Association received a fair test at the Boston meeting. It gave more time to the sections and greatly reduced the amount of more or less wearisome debate which in former years wasted much time.

THE remarks of President Eliot, in his admirable address before the American Association, on the importance of scientific advice to the nation in time of war, was emphasized by the fact that both the Vice-President, Professor Cooley, and the Secretary, Professor Aldrich, of Section D. (Mechanical Science and Engineering) were detained from attendance at the meeting owing to active service in the Navy.

AT the recent meeting of the American Association, Professor E. W. Morley was appointed to succeed the late Professor W. A. Rogers on the Committee on Standards and Measurements.

THE University of Cambridge has conferred the honorary degree of D.Sc. on Professor Henry P. Bowditch, of Harvard University.

PROFESSOR EDWARD S. MORSE has just been decorated by the Emperor of Japan with the Order of the Third Class of the Rising-Sun. A letter from the Japanese Minister at Washington translates the diploma accompanying the Order as follows: "His Majesty, the Emperor, has graciously been pleased to confer upon you this Order in recognition of your signal service while you were in the faculty of science in the Imperial University in Tokio, and also in opening in our country the way for zoological, ethnological and anthropological science and in establishing the institutions for the same."

DR. MARK V. SLINGERLAND, of Cornell Uni-

versity, has been appointed State Etomologist of New York in place of the late Dr. J. A. Lintner.

THE proposed session of the New Mexico Biological Station at Albuquerque in August has been given up on account of the prevalence of smallpox in that vicinity.

A SCIENCE CLUB has been formed at Mesilla Park, N. M. Mr. C. M. Barber is President.

THE opening of Queen Victoria's Cottage Grounds at Kew Gardens will be delayed until spring, as there are no funds available this year for the cost of fencing and other necessary work which must first be carried out.

THE young male giraffe from Senegal, which was one of the latest additions to the menagerie of the Zoological Gardens at London, and for which the Society paid £900, has just died.

THE Report of the South African Museum at Cape Town states that the total number of visitors to the Museum during 1897 was 56,723; this, notwithstanding the fact that the Museum was only open for a little more than eight months is 7,313 in excess of the previous year. The monthly average is 6,482, and the daily average 254, the largest number on a single day being 2,993 on June 22d, the lowest, 96, on November 24th.

MR. J. MACKAY BERNARD KIPPENROSS has contributed the sum of £500 in order that the Ben Nevis Observatories may be continued another year. In his letter to the Scottish Meteorological Society, quoted in *Nature*, Mr. Kippenross expresses the hope that before the end of that year arrangements may have been made for the permanent carrying-on of the work by State aid, and his very liberal and prompt action makes the Directors more hopeful than they were that this desirable end may yet be reached. The question of the position of the Ben Nevis Observatories was brought up in the House of Commons on August 5th, in connection with the annual vote of £15,300 to the Meteorological Council for meteorological observations. The Ben Nevis Observatories now receive an annual grant of £350 from this fund. Mr. Hanbury, Financial Secretary to the Treasury, has undertaken to ascertain whether a larger amount could not be voted, the sug-

gestion being made that a grant of £500 a year should be made for five years.

EXPERIMENTS are being undertaken by Professor Lawrence Bruner, of the University of Nebraska, to determine the methods that might be used in spreading among our native species a locust disease discovered by him in South Africa last year. The disease is closely related to the fungus used for destroying chinch bugs in some parts of the United States. Professor Bruner contributes an article on the subject to the July bulletin of the Nebraska Section of the Climate and Crop Service of the Weather Bureau.

THE *British Medical Journal*, quoting from the *Morning Post*, states that two members of the Italian Chamber of Deputies, Signor Leopoldo Franchetti and Signor Fortunato, have issued a circular proposing the foundation of a society for studying the phenomena of malaria. "The malaria," they state, "keeps 2,000,000 hectares (nearly 5,000,000 acres) of ground in Italy from cultivation; it effects, more or less, 63 provinces and 2,823 communes; and every year it poisons about 2,000,000 inhabitants, killing 15,000 of them. It is impossible to estimate the economic damage done to our country by the scourge, and no sanitary problem is more intimately bound up with the question of our prosperity." The authors of the circular, therefore, propose that a society be formed for studying malaria and for discovering the best means of combating it. Those who contribute 500 lire will have the title of founders, and ordinary members will pay 36 lire a year. Signor Franchetti and Signor Fortunato have subscribed 1,000 lire each.

THE first Congress of Legal Medicine will be held at Turin in October, under the presidency of Professor Lombroso.

A METEOROLOGICAL department in connection with the Federal telegraph service has just been established in Mexico.

THE government of British Guiana has lately taken steps of great practical utility in arranging for geological surveys in the gold districts. *Nature*, quoting from a report on the gold and forest industries of British Guiana, states that a survey has already been conducted by Professor J. B. Harrison in the northwest district

and the results embodied in a report, while an additional report on the petrology of the district is awaiting publication. A further expedition to examine the formations of the Potaroc-Conawarook district is now being organized. The great importance of this work will be recognized in view of the fact that there are no trustworthy official reports on the geology of British Guiana in existence. The experience of the past ten years has proved that British Guiana is rich in gold; and what is now needed is the importation into the colony, and the adoption of, mechanical washing appliances for alluvial gold. By such means deposits of alluvial gold, vast areas of which are known to exist, but would not pay to work by the means now employed, could be made to produce large quantities of gold. During the year ending on June 30th the amount of gold exported from the colony was 117,265 ounces, or a decrease of 10,326 ounces upon the output of 1896-97. This serious decrease is partly ascribed to exceptionally bad weather, and partly to the exhaustion of alluvial workings in the Barima district.

THE N. Y. Fisheries, Game and Forest Commission proposes to purchase about 50,000 acres of land in the Catskills, in addition to the 56,212 acres already owned by the State. The Commission reports that deer are increasing very rapidly in the Catskills. It is estimated that the 44 animals turned loose about a year ago have increased to 150, and that there will be between 400 and 500 of these animals at the expiration of the five year period during which their killing is prohibited.

---

#### UNIVERSITY AND EDUCATIONAL NEWS.

THE second cousins of Dr. Elizabeth H. Bates, who died at her home at Port Chester, N. Y., a few months ago, leaving the University of Michigan an estate valued at \$125,000, for the establishment of a chair for diseases of women and children, have filed a notice at Ann Arbor that they will contest the will.

AT the New Mexico Agricultural College and Experiment Station, Professor C. H. T. Townsend has been appointed Biogeographer and Systematic Entomologist to the Station; E. O.



Wooten has been appointed professor of botany, and T. D. A. Cockerell has been appointed professor of entomology in addition to being Station Entomologist.

ROBERT B. OWENS, for the past seven years professor of electrical engineering in the University of Nebraska, has resigned in order to accept a similar position in McGill University, Montreal. His successor has not yet been appointed.

T. PROCTOR HALL has been appointed professor of physics in Kansas City University.

DR. BLOCHMAN, professor of zoology in the University of Rostock, has been called to Tübingen as successor to the late Professor Eimer; Dr. Fritsch has been appointed Director of the Botanical Museum of the University of Vienna; Dr. D. K. Morris, lecturer in technical electricity in the Mason University College, Birmingham; Dr. D. Frazer Harris, lecturer in physiology in the University of St. Andrew's. Dr. Kerschner, of the University at Innsbruck, has been promoted to a full professorship of histology; Dr. Reitzenstein, of the University of Mühlhausen, has qualified as docent in chemistry in the University at Würzburg; Dr. Kolkwitz, in botany in the University of Berlin; Dr. Klingenberg, in mechanical engineering, in the Polytechnic Institute of Berlin; Dr. Schröter, in botany, in the University at Bonn, and Dr. Rothmund, in physical chemistry, in the University of Munich.

#### DISCUSSION AND CORRESPONDENCE.

ON THE OCCURRENCE OF PLACOCEPHALUS (BIPALIUM) KEWENSE IN THE SANDWICH ISLANDS.

TWO specimens of land-planarians from the Sandwich Islands were sent to the writer from the National Museum for identification which proved to be the interesting Placocephalus (Bipalium) Kewense. They were taken by Dr. Steiniger in November, 1896, on the island of Oahu, at the top of the Pali, near Honolulu. The specimens were small ones, and in the living condition could not have exceeded 150 mm. in length. If we except New Zealand, this form has been known in the Pacific only from Upolu, one of the Samoan Islands, and its occurrence in the Sandwich Islands is of es-

pecial interest in bridging over a large gap in the distribution of so cosmopolitan a form. Doubtless it has also been introduced there, where so much of the vegetation is of foreign origin.\*

The writer† has recorded the occurrence of this species in the United States at Cambridge, Mass., and has since received specimens from Baltimore, Md.; Pittsburg and Allegheny, Pa., and Springfield, Ohio, in every case from green-houses. Outside of the tropics the form has been taken only in plant houses. The writer would be grateful for any specimens or information from the Pacific Coast.

W. McM. WOODWORTH.

MUSEUM OF COMPARATIVE ZOOLOGY,  
CAMBRIDGE, MASS., August 15, 1898.

#### SCIENTIFIC LITERATURE.

*La Theorie Platonicienne des sciences.* Par ÉLIE HALÉVY. Paris, Félix Alcan.

It is to be feared that Mr. Halévy and his reviewer have gained admission to the pages of SCIENCE under cover of an *équivoque*. The word 'sciences' in Mr. Halévy's title has perhaps a somewhat broader meaning than that it bears in ordinary English usage. It is rather 'knowledge' than 'science.' Mr. Halévy's book is not an account of Plato's supposed contributions to mathematics and astronomy, or a discussion of his casual utterances concerning the inchoate physical sciences of the fourth century B. C. It deals rather with epistemology than with physical science. Its main thesis is that the Platonic philosophy is the result of a dialectical analysis of the epistemological conditions of the sciences—of the 'knowledges,' of the certainty of human knowledge. The arts and sciences exist. What are the logical presuppositions of their existence and of our sense of certainty regarding them? Whatever philosophy of ideas is involved in the very existence of a body of arts and sciences must be a true philosophy. In constructing such a philosophy out of Plato's dramatic dialogues Mr. Halévy displays great ingenuity and power of consecutive logical thought. He over-refines,

\* For the distribution of this interesting form see Colin, A. Sitzungsber. Gesell. naturf. Freunde, Berlin, Jahrg., 1892, No. 9, p. 164.

† *American Naturalist*, Vol. XXX., p. 1046, 1896.



over-systematizes, and occasionally strains the meaning of a text. But those who agree with him least will profit by rethinking with such a vigorous and subtle intelligence the entire content of Plato's thought. More specific criticism would involve us in questions of metaphysics or in the philological interpretation of texts. Instead of entering upon these details I propose to avail myself of this opportunity to say a word concerning Plato's attitude towards the physical sciences, and the notion, widely prevalent among modern men of science, that, while Aristotle is the 'master of those who know' and the pioneer of science in a prescientific age, Plato is the master of those who dream and the incarnate antithesis of the scientific spirit. If this is an error, a brief statement of its causes may be not without interest. Chief of these is the fact that Plato, despite his high attainments in mathematics, was essentially a literary artist and philosopher, while Aristotle, as Lewes' well-known book shows in detail, was a serious investigator, or at least collector of facts, in the biological sciences, and said one or two very quotable things about the charms of the study of Nature's humblest products.

But the question is not so much of professional occupation as of temper, insight and influence. Now Plato, taking for granted the secondary education in 'music' and gymnastics, demanded that the higher education should be based on a firm foundation of mathematics, astronomy, and mathematical physics; he asked for the endowment of scientific research, and in his *obiter dicta* concerning the imperfect science of his time he displayed marvellous tact in avoiding the colossal errors into which Aristotle was led by his reliance on verbal definitions and his 'spirit of system.' How is it, then, that the popular judgment sets Plato down as an opponent of science? No better explanation can be found than Bacon's statement that Plato corrupted science by theology, while Aristotle corrupted it by logic. Plato's predominant ethical interest and his dread of a certain hard dogmatic materialism associated with the name of Democritus led him to insist on the antithesis of spirit and matter, and on a teleological view of the world, in language which sentimentalists have employed as a weapon in the supposed

'warfare of religion and science.' Like Emerson, he has borne the burden of the folly of disciples attracted to him solely by a vague sense of the spiritual edification and beauty dimly apprehended in his words. Of course, a teleological view of the world is wholly compatible with science provided the teleology be sufficiently abstract and comprehensive. It is the '*sur-naturel particulier*' with which science wars. But just here Plato's literary and poetic genius has done him harm with certain severe but somewhat literal-minded thinkers. For in his *Timæus* he deliberately undertook to make the entire universe, as known to the science of the fourth century B. C., a poetical allegory of spiritual and teleological meanings. The literary beauty of this 'Hymn of the Universe' is a matter of taste—perhaps of acquired taste. But its crude literal acceptance is possible only to a defective historic sense, and leads to the grossest misinterpretations both of Plato and of ancient thought generally. Now, unfortunately, the chief source from which too many men of science derive their impression of Plato's conception of the world is precisely the *Timæus* in the bald, literal and unsympathetic *résumés* given by Grote and Draper. I hope I shall not be accused of wilful paradox when I add that this illustrates one of the chief dangers of an education exclusively in physical science—the excessive reliance on authority.

'Science,' of course, knows no authority, and in the end tests all things. But the individual man of science, unless he undertakes to repeat the entire investigation, must accept the experimental results of his confrères on authority, first satisfying himself, if possible, of the general validity of the method and the good scientific standing of the investigator. This habit of mind he takes with him to the study of historical and philological questions where (I do not speak of the general public) it is much easier to control an investigation by an appeal to the sources, and where consequently (among trained men) secondary authorities count for less. It would be interesting to illustrate this by the abuse formerly of Lewes' 'Biographical History of Philosophy,' and, since Tyndall's Belfast address, of Lange's clever but one-sided 'History of Materialism.' But I have already

abused my usurped license of wandering from my text.

PAUL SHOREY.

UNIVERSITY OF CHICAGO.

*The Story of the Atmosphere.* By DOUGLAS ARCHIBALD. Published in the Library of Useful Stories. New York, D. Appleton, & Co. 1897. Price, 40 c.

In the 'Story of the Atmosphere,' Mr Archibald has given us an excellent popular account of the most important features of modern deductive meteorology. His success in presenting the subject in such an elementary manner is really remarkable, and is without doubt due to his many years' interest in this branch of the science. Few Englishmen appear to have been greatly attracted by the deductive treatment of meteorology, and those who have shown by their writings that they have been pursuing this line of study have been most strongly represented by the Indian meteorologists, and foremost and earliest among these must be placed Blanford; and no Englishman has followed his lead more closely than Mr. Archibald, whose writings have received well merited attention during the past fifteen or twenty years.

It is, then, with the knowledge that Mr. Archibald is thoroughly familiar with his subject that we enter upon the perusal of his book; and, as we finish it, we must admit it to be an important and very satisfactory addition to our popular science literature.

Mr. Archibald has shown great skill in selecting the material that he presents to the reader, and he has given it in a very interesting manner. It is, however, more of a student's book than might appear at first sight. It is just the book for a well educated man or woman to take up and read as supplementary to studies formerly pursued in schools, and in the hands of a teacher of meteorology or physical geography it will prove a valuable addition to the elementary text-books on those sciences.

Mr. Archibald's remarks on the origin and height, nature and composition, pressure and weight, of the atmosphere are clear and interesting; but the chief value of the book, in the eyes of a specialist, lies in the chapters on the temperature and motions of the atmospheric

air. In these the author gives the reader the full benefit of his study of meteorological literature of various lands during the last score of years; during which time dynamical meteorology has made remarkable advances as a science, owing to the labor of various eminent physicists who have devoted considerable attention to it. In this portion of the book Ferrel's work has been given the prominence which it deserves, and the subjects presented have probably never been given in a clearer manner. It is interesting to note that the author has wisely reproduced some of Ferrel's original diagrams which have historic value.

Probably the most interesting chapter to the average reader is the one on 'Suspension and Flight in the Atmosphere.' This gives a succinct account of aerial navigation of all kinds—bird flights, ballooning, kite flying, air ships, etc. The various problems pertaining to these are elucidated and commented on with great discrimination. The last chapter deals very briefly but suggestively with 'Climate and Life in the Atmosphere.'

FRANK WALDO.

GREAT SMOKY MOUNTAINS, N. C.

#### NEW BOOKS.

*Researches in the Uloa Valley, Honduras; Caverns of Copan.* GEORGE BYRON GORDON. Cambridge, published by the Peabody Museum. 1898. Pp. 44 and 12 Plates.

*Catalogue of Scientific Periodicals, 1865-1895.* H. CARRINGTON BOLTON. Second Edition, 1897. Washington, Smithsonian Institution. 1898. Pp. vii+1247.

*Forestry Conditions in Northern Wisconsin.* FILBERT ROTH. Madison, Published by the State. 1898. Pp. vi+78.

*Instincts and Habits of the Solitary Wasps.* GEORGE W. PECKHAM and ELIZABETH G. PECKHAM. Madison. 1898. Pp. iv+245 and 14 Plates.

*Symons' British Rainfall, 1897.* G. J. SYMONS and H. SOWERBY WALLACE. London, Stanford. 1898. Pp. 239.

*Calcul des conduites d'eau.* G. DARIES. Paris, Gauthier-Villars et fils. 1898. Pp. 194.

# SCIENCE

EDITORIAL COMMITTEE: S. NEWCOMB, Mathematics; R. S. WOODWARD, Mechanics; E. C. PICKERING, Astronomy; T. C. MENDENHALL, Physics; R. H. THURSTON, Engineering; IRA REMSEN, Chemistry; J. LE CONTE, Geology; W. M. DAVIS, Physiography; O. C. MARSH, Paleontology; W. K. BROOKS, C. HART MERRIAM, Zoology; S. H. SCUDDER, Entomology; C. E. BESSEY, N. L. BRITTON, Botany; HENRY F. OSBORN, General Biology; C. S. MINOT, Embryology, Histology; H. P. BOWDITCH, Physiology; J. S. BILLINGS, Hygiene; J. MCKEEN CATTELL, Psychology; DANIEL G. BRINTON, J. W. POWELL, Anthropology.

FRIDAY, SEPTEMBER 9, 1898.

COLOR-VISION.\*

## CONTENTS:

<i>Color-Vision</i> : PROFESSOR FRANK P. WHITMAN.....	305
<i>A Half Century of Evolution, with Special Reference to the Effects of Geological Changes on Animal Life (III.)</i> : PROFESSOR ALPHEUS S. PACKARD.....	316
<i>Reports of Committees of the American Association for the Advancement of Science</i> :—	
<i>Sixteenth Annual Report of the Committee on Indexing Chemical Literature</i> : DR. H. CARRINGTON BOLTON, CHAIRMAN.....	323
<i>Report of the Committee on Standards of Measurement</i> : PROFESSOR HENRY S. CARHART, SECRETARY.....	326
<i>Current Notes on Anthropology</i> :—	
<i>Initiation Ceremonies in Australia; The Tarascan Language; Anthropological Pessimism</i> : PROFESSOR D. G. BRINTON.....	328
<i>Notes on Inorganic Chemistry</i> : J. L. H.....	328
<i>Scientific Notes and News</i> :—	
<i>Color-Vision</i> : C. L. F. <i>Experiments with Kites at Blue Hill Observatory; The Prevention of Consumption</i> ; General.....	329
<i>University and Educational News</i> .....	334
<i>Discussion and Correspondence</i> :—	
<i>Basil Valentine</i> : PROFESSOR T. D. A. COCKRELL.....	335
<i>Scientific Literature</i> :—	
<i>Seward's Fossil Plants for Students of Botany and Geology</i> : PROFESSOR LESTER F. WARD.....	335
<i>Scientific Journals</i> .....	340
<i>New Books</i> .....	340

THE domain of physiological optics, formerly much frequented by students of physics, has of late been administered chiefly by psychologists. So far is this true that I have hesitated in preparing an address upon a subject in this realm, lest I should be accused of passing entirely beyond that borderland which lies between us and our sister science, of trespassing in a foreign country, and risking international complications. Yet a subject which has owed its development to Newton and Young, Maxwell and Helmholtz, to mention no other names, can hardly be out of place here. The methods of investigation are largely those of the physicist, the phenomena attend every optical research, the results are of frequent physical application. Within the past few years, however, most of the work on color-vision has been done by other hands, and the results have not appeared in the physical journals. It seemed worth while, therefore, to review briefly the progress of scientific theory in this direction, and to sum up, so far as possible, the present state of our knowledge.

For our purpose we must go back as far as Sir Isaac Newton, to whom we owe the first definite and intelligible hypothesis as to the nature of color-vision.

MSS. intended for publication and books, etc., intended for review should be sent to the responsible editor, Professor J. McKeen Cattell, Garrison-on-Hudson, N. Y.

\*Address of the Vice-President before Section B—Physics—of the American Association for the Advancement of Science, August, 1898.



"If at any time," he says, "I speak of Light and Rays as coloured or endued with Colours, I would be understood to speak not philosophically and properly, but grossly, and according to such Conceptions as vulgar People in seeing all these Experiments would be apt to frame. For the Rays to speak properly are not coloured. In them is nothing else than a certain Power and Disposition to stir up a Sensation of this or that Colour."

"For as Sound in a Bell or musical String or other sounding Body is nothing but a trembling motion, and in the Air nothing but that Motion propagated from the Object, and in the Sensorium 'tis a Sense of that Motion under the form of Sound; so Colours in the Object are nothing but a disposition to reflect this or that sort of Rays more copiously than the rest; in the Rays they are nothing but their dispositions to propagate this or that motion into the Sensorium, and in the Sensorium they are Sensations of those Motions under the forms of colours."\*

Again, with greater definiteness, Newton writes: "To explain colours, I suppose that as bodies of various sizes, densities, or sensations, do by percussion or other action excite sounds of various tones, and consequently vibrations in the air of different bigness, so the rays of light, by impinging on the stiff refracting superficies, excite vibrations in the ether \* \* \* of various bigness; the biggest, strongest, or most potent rays, the largest vibrations; and others shorter, according to their bigness, strength, or power; and therefore the ends of the capillamenta of the optic nerve, which pave or face the retina, being such refracting superficies, when the rays impinge upon them, they must there excite these vibrations, which vibrations (like those of sound in a trunk or trumpet) will run along the aqueous pores or crystalline pith of the capil-

\*Opticks: 3d edition, 1721, p. 108.

lamenta, through the optic nerve into the sensorium; and there, I suppose, affect the sense with various colours, according to their bigness and mixture; the biggest with the strongest colours, reds and yellows, the least with the weakest, blues and violets; the middle with green; and a confusion of all with white, much after the manner that in the sense of hearing, Nature makes use of the aerial vibrations of several bignesses, to generate sounds of divers tones; for the analogy of Nature is to be observed."\*

These passages are quoted—and several others might be added—to show that Newton ascribes no peculiar function or activity to the terminals of the optic nerve. They are set in vibration by the rays of light; their vibrations are transmitted to the higher regions of the sensorium, where they become sensations of light and color. As to the physical nature of the rays themselves, or the reason why they should excite in the nerve-fibres vibrations of different length, Newton makes no guess.

This is a definite theory of color-perception, and, as Rutherford has pointed out, one of great value, but presenting obvious difficulties.

Some of these difficulties led Thomas Young to that modified form of Newton's views, which in the famous Bakerian lecture, he describes as follows: "Since \* \* \*, it is probable that the motion of the retina is rather of a vibratory than an undulatory nature, the frequency of the vibrations must be dependent on the constitution of this substance. Now, as it is almost impossible to conceive each sensitive point of the retina to contain an infinite number of particles, each capable of vibrating in perfect unison with every possible undulation, it becomes necessary to suppose the number limited, for instance, to the three principal colours, red, yellow and blue \* \* \* and that each of the particles is capable of being put

\*Quoted by Yonng, *Phil. Trans.*, 1802, p. 19.



in motion less or more forcibly, by undulations differing less or more from a perfect unison; \* \* \* and each sensitive filament of the nerve may consist of three portions, one for each principal colour." Young, as is well known, afterward substituted green for yellow, in his triad of principal colors.

It is to be observed that the 'particles' spoken of in the above quotation, as vibrating in unison with the undulations of light, are not to be considered as molecules, in the modern sense. He speaks of them as particles, then as sensitive filaments, and in a later paper on the same subject as 'sympathetic fibres.' A supposition, such as has been urged, that Young is here speaking of molecular constitution, and anticipating the photo-chemical theories of our own day, is an anachronism. Young is thinking of the wave-theory of light, and of sympathetic vibrations, or, as we should say, of resonance. One who meant chemical decomposition would not speak of the shattered molecules as *sympathetic fibres*. Young, in fact, is not consciously proposing a new theory, much less one so startlingly different. He is simplifying Newton's, making for that purpose four hypotheses, three of which, as he remarks himself, 'are literally parts of the more complicated Newtonian system.' Young's theory seems to have attracted little attention, until brought once more to public notice by Helmholtz, in 1860.

Helmholtz suggests one objection to the theory, and a modification to obviate the objection, but remarks that the essence of the theory does not lie in this or that special assumption, but in the fact that the color-sensations are conceived as compounded out of three entirely independent properties in the nerve-substance.

Therefore, he says, if only for the sake of clearness of representation, he uses Young's original and simple form of statement, ascribing the different color-sensa-

tions to three-kinds of nerve endings in the retina, sensitive respectively to red, green and violet light, the sensation of white to the equal excitation of all three sets of nerve-fibres, and color-blindness to the absence of one or more of the sets of such fibres. He puts into Young's words, however, an entirely different meaning, by classifying Young's hypothesis as 'only a special application of the law of specific sense-activities.' This statement, a most natural one to a pupil of Johann Müller, changes the whole character of the theory, and makes it really a new one.

The hypothesis in this simple form met very well the conditions of normal vision, and the cases of color-blindness thus far studied. Difficulties soon arose. Color-blindness, especially red-blind persons, persisted in calling the principal colors seen in the spectrum, yellow and blue, instead of green and blue, as they should have done if the red sensation were simply absent. It was long supposed that this was merely a question of naming the colors, and that those actually seen were green and blue. So lately as 1892 the report of the British Association committee on color-vision contains colored spectrum-plates, in which the spectrum as seen by a red-blind person is shown as composed of green and blue, while that seen by a green-blind person is formed of red and blue. Abney prefixes the same plate to his Tyndall lectures on color-vision, published in 1894. But in 1881 Hippel\* and Holmgren† had examined the vision of a person, one of whose eyes was normal, the other typically color-blind. All the long-waved end of the spectrum was described as yellow, the sensation being tested by comparison with the normal eye. Other cases of color-blindness, arising from disease, corroborate this testimony.

\* Arch. f. Ophthal., XXVI. (2), p. 176, 1880; XXVII. (3), p. 47, 1881.

† See Proc. Roy. Soc., No. 209.

It is evident that a simple absence of one of the fundamental sensations is not enough to account for the facts.

But more than the ordinary color-blindness comes into the question. It was discovered that the normal eye is color-blind by indirect vision, the condition gradually increasing from the central portion outward, and culminating in the periphery of the retina in absolute insensibility to color. The sensation of white cannot in this case be produced by a mixture of three color-sensations, because color-sensation does not exist.

In 1777 was described, in the Philosophical Transactions of the Royal Society, the well-known case of the shoemaker Harris, apparently the first recorded case of complete color-blindness. In 1871 Donders made a careful study of another case. So rare is this defect, however, that so assiduous an observer as Holmgren in 1877 had never seen it and doubted its existence, and in 1889 Helmholtz simply passes it by, saying that the eye so affected is always in other ways ailing and sickly, the implication being that the effect was so far from the ordinary and so pathological in character that it need not be considered. But by 1892 a sufficient number of such cases had been examined to establish the existence of this as a distinct type of color-vision, and one which must be accounted for.

A third and even more striking departure from the simple conditions of the original theory was found in the remarkable change in the character of color-sensations in faint light, the spectrum becoming simply a colorless strip of graduated brightness.

We have then three different types of varying color sensibility :

1. In the eyes of different persons, beginning with the normal-eyed, passing through the variation studied by Rayleigh and Donders, which while recognizing all

colors, yet in the character of the sensations makes a step toward green-blindness, then the two well-marked divisions of the color-blind, red- and green-blind, and finally the eye which perceives no color. These different classes are well marked, and few intermediate forms are found.

2. In the same eye, under differing degrees of brightness. As the spectrum gradually diminishes in brightness the colors change. Red tends toward yellow, yellow toward green, green becomes bluish. All the colors vanish by degrees, red disappearing first, and the spectrum, still visible through the greater part of its length, appears without color. Here the intermediate stage is a sort of red-blindness, but the final result is the same for all eyes, that is, the distribution of brightness for the normal and the color-blind eye appears to be precisely the same, a circumstance, as we shall see, of much importance.

3. In a single eye, passing from the center outward. The fovea and the zone surrounding it are sensitive to all colors. Outside of this the eye becomes gradually insensitive to color, the sensation of red and green disappearing first, afterwards yellow, and finally blue. The outer part of the retina is insensitive to all color, but its condition may be quite different from that of the eye of a totally color-blind person, or a normal eye in faint light.\*

In attempting to account for these varied phenomena the Helmholtz theory loses its striking simplicity. It is no longer possible to explain color-blindness by the absence of one or more sets of sensitive fibres, or the white seen by a totally color-blind retina, as compounded from the three fundamental sensations, in any ordinary way.

Helmholtz, in 1860, made the suggestion, which was afterward amplified by Fick and König, of a possible changeability in the

\* von Kries, *Centralblatt f. Physiologie*, X., pp. 745-749, 1896.

character of the three fundamental sensations. Albert, in 1882, from a study of the color changes in faint light, pointed out the direction and character of the corresponding sensation-changes.\*

A method by which such changes might be brought about was not difficult to suggest. The idea of Newton and Young, of nerve-fibres vibrating in unison with the light-waves, had grown increasingly improbable as, on the one hand, the rate of vibration of light became known, and on the other the maximum rapidity of vibration transmissible by a nerve-fibre, which is a quantity of an entirely different order. Hence most modern theorists have turned to photo-chemical action, and Helmholtz among the rest, although with characteristic caution, he advocates no particular form of light effect, resting the claims of his theory, in the second edition of his great book as in the first, on the physical possibilities of representing all colors by means of three. But if we suppose red-sensitive, green-sensitive and violet-sensitive molecules, there is no difficulty, when one thinks of modern photographic processes, in supposing that the green-sensitive substance, for example, may be so chemically changed as to coincide in character with the red-sensitive. Each would send to the brain the impression of its own characteristic color, while each would be affected in exactly the same manner by any given light. In other words, the color curve corresponding to the sensation of the fundamental green in the Young-Helmholtz theory would be more or less perfectly superposed upon that of the fundamental red.

As a result, there would be no more sensation of green or red, but only of their compound, yellow. Now this is just what a color-blind person sees, as Hippel and Holmgren showed in their long-neglected papers already referred to.

\* Albert, *Wied. Ann.*, 16, p. 129, 1882.

So peripheral color-blindness may be explained by a gradual approximation of the three color-substances, and a gradual superposition of the corresponding sensation-curves, until in the outer zone all three coincide.

But when we attempt to apply this suggestion to all the changes noted before, in ordinary color-blindness, peripheral color-blindness and twilight color-blindness, as von Kries happily calls it, the shifting of the curves becomes so great and so various that we realize that we are dealing no longer with a scientific theory, but with fanciful and arbitrary arrangement. As a first approximation, the Young-Helmholtz hypothesis is valuable, leading to simple and definite connections between great numbers of facts. As a detailed explanation of existing phenomena it is unsatisfactory, and growing more so daily.

One thing is becoming brightly evident, that the sensation of brightness, perhaps also the sensation of white, must be accounted for in some other way than as a summation-effect of separate color-sensations. Another class of phenomena points yet more directly to this view. I refer to the discovery of Rood that the effect of sudden variations in brightness, the 'flicker' sensation, is dependent on brightness alone, and not upon color. It is difficult for one who has seen how easily and definitely a red and a gray, or a red and a blue, can be compared in brightness by this method, to believe that brightness is not an independent sensation. The words of Helmholtz are worth quoting here. "As to myself," he says, "I have always the feeling that in photometric comparison of different colors it is a question, not of the comparison of one sort of magnitude, but of the combined effects of two, brightness and color, of which I cannot form a simple summation and of which I can give no scientific definition."

The strongest point of attack upon the



Young-Helmholtz color-theory has, in fact, always been the explanation of the white-sensation, and one of the principal advantages of the theory proposed by Hering in 1874 was the separation of the white-sensation, which he identified with the sensation of brightness, from special connection with the color-sensations, or rather his including it, upon the same level, in the list of his three sets of opposing colors, black-white, red-green, yellow-blue.

A photo-chemical substance is supposed to exist in the eye—where it is not decided—which possesses the remarkable property that if acted upon by light of one wave-length its molecules are dissociated or dissimilated; if acted upon by light of another wave-length they are built up or assimilated again. This substance exists in three forms: One is, let us say, dissimilated by red light, assimilated by green; one is similarly acted upon by yellow and blue, and one by white and black. There are thus six color-processes, arranged in three pairs. They are antagonistic in character, so that if red and green, or yellow and blue light act on the retina at the same time and with equal strength they neutralize each other and the sensation of color is completely destroyed. It is difficult to form a clear conception of these processes. Photo-chemical actions of somewhat antagonistic character are well known, but the analogies between them and the visual processes are hardly close enough to be of great assistance.

The hypothesis, however difficult to conceive of in itself, is very definite, and explains as well as the Young-Helmholtz theory the results of ordinary color-vision, and in respect to subjective phenomena, as contrast, or after-images, is much more satisfactory, in formal statements at least. But it fails equally, though for different reasons, to explain satisfactorily the more lately discovered or less evident phenomena of vision.

Complementary colors are regarded, on this theory, as mutually destructive, the one representing an assimilative, the other a dissimilative process. The white or gray which results from their combination is due to the action on the white-black visual substance, which was unperceived in the separate colors, being masked by their greater brilliancy, but becomes effective when they are neutralized by mixture. If two equal grays are formed, one let us say from red and green, the other from yellow and blue, they must according to the theory contain equal amounts of white, and the colors in each are completely neutralized. They should, therefore, remain equal at all degrees of brightness. But Ebbinghaus,\* by mixing spectral colors, and Mrs. Franklin,† with color-disks, have shown that this is not true. If they are made equal when bright, and the intensity gradually diminished, the red-green mixture greatly exceeds in brightness. If they are equated when of feeble intensity, and then made brighter, the yellow-blue mixture surpasses. König‡ has lately examined this with much elaboration, confirming these results, and showing also that the brightness of a gray obtained thus by mixture is always equal to the sum of the brightness of the separate colors, whether by bright or faint light.

This single experiment, so amply confirmed, appears completely destructive to Hering's fundamental hypothesis, at least in its original and simple form.

It may be remarked in passing that photometric methods which have been proposed, of comparing lights of different colors by reducing their brightness until the color-differences vanish, are worthless.

Other phenomena of similar character exist which are equally difficult of explanation.

\* *Zeitschrift für Psychol. und Physiol. Sinnesorgane*, V., p. 145, 1893.

† *Mind*, N. S., II., p. 487, 1893.

‡ *Ber. d. Preuss. Akad.*, p. 945, 1896.



tion. Hering regards some of these as phenomena of adaptation, and shows, in his remarkable paper on Purkinje's phenomenon, published in 1895, that the state of the retina, as conditioned by previous exposure to light, affects greatly the perception of color. Attention to this fact is necessary in photometric comparisons. The eye should be kept in the same condition, as nearly as possible, throughout any set of observations. But careful measurements by von Kries and others, keeping the eye carefully adapted for brightness, have proved that Purkinje's phenomenon exists, whatever the state of the eye, though much modified by adaptation.

Another cause of false color-appreciation, insisted upon by Hering, is the pigmentation of the macula. This is certainly of importance. In experiments with color-disks the apparatus, to secure consistent results, must always be placed at the same distance from the eye. A color-match made with the disks close to the eyes will in general not hold if the observer steps back a few feet, because the macula covers in the two cases a very different portion of the retinal image of the disks. The region corresponding to the macula, indeed, can generally be seen projected upon the surface of the revolving disks, as a spot inclining more to reddish than the remainder of the surface. The intensity of the yellow pigment, differing in the eyes of different people, must affect their general perception of color.

The well-marked divisions of color-blind, into green-blind and red-blind, as they would be called in the Young-Helmholtz theory, were explained by Hering as due to the more or less deeply pigmented macula. But the utter inadequacy of this explanation has been abundantly shown.

Perhaps the most striking difference between the Hering hypothesis and the facts is shown in the distribution of color-sense

in different parts of the retina. Ability to distinguish colors decreases gradually from the center to the exterior. The distinction of red and green disappears first, then the yellow becomes uncertain, and finally blue disappears, the outer zone of the retina being devoid of color-sense. The zones are not well defined, varying with the brightness of the light and the size of the colored surface. But making due allowance for these circumstances, the area within which red is distinguishable differs from that occupied by green, and the yellow sensation differs in extent from the blue. If red and green, or yellow and blue, are due to the presence of the same visual substance it seems that the boundaries should be co-extensive.

Even the sensation of white presents similar variations. There are, as has been already said, three cases in which the color-sense is wanting: the totally color-blind eye, the normal eye in faint light, and the periphery of the retina. The brilliant discovery of Hering, in 1891, that the distribution of brightness in the spectrum in the first two cases is the same, aroused great interest in the theory of the sensation of white, and went far toward establishing its position as a distinct and separate sensation. The third case, it was taken for granted, fell under the same law. But in 1896 von Kries showed that the distribution of brightness in the spectrum as seen by the outer zone of the retina is different, being practically the same as in the central portion, with its maximum in the yellow, and that the peripheral zone in the retina of a color-blind person shows the same deficient sensation for the longer wave-lengths as in the color-perceiving portion of the eye.

This is a matter of so much interest that I have re-examined it with the flicker photometer, with results differing materially from those of von Kries. According to my experiments, the brightness of the colors of

long wave-length diminishes continually, while that of the shorter wave-lengths increases continually, from the center of the visual field to its circumference. The conditions under which von Kries worked, however, were so different from mine that I cannot regard my results so far as necessarily invalidating his. If his results are confirmed, they show that the sensation of white in the normal eye is not completely determined by the twilight sensation, or that of the totally color-blind. It contains elements derived from, or connected with, the mechanism producing the sensation of color, even in those portions of the retina where no color-sensation exists.

I have discussed these two theories somewhat at length, because our growth in knowledge of the facts of color-sensation has been conditioned largely by their existence. The enormous amount of work which has been done on the vision of the color-blind, on color-vision by varying illumination, on peripheral color-vision, not to mention researches upon more purely subjective phenomena, has been largely suggested by aspects of one or the other of these theories, or undertaken with a view to testing portions of them, and there has seemed no better method exhibiting the results of these researches than by placing them in connection with the hypotheses they were intended to test. I need hardly add that I have been greatly aided in this summing up by the polemical writings emanating from the hostile schools.

In this respect, at least, the two theories have been eminently useful, and have fulfilled one of the chief requirements of a scientific theory—that its explanations can be tested by experiment. The earlier forms of color-theory suggested by Newton and by Young were hardly such. So long as the specific effect was conceived to be entirely in the central organ, to which the nerves merely communicated the vibrations of

light, there was little upon which to base experimental work. Helmholtz, by ascribing the specific activity to the nerve-ending itself, made it necessary to describe this activity in some definite way, which could then be tested. The very simplicity of the conceptions of Helmholtz and Hering, at first the apparent guaranty of their truth, has proved their greatest value, but also their greatest difficulty.

It is not to be wondered at that later theorists have attempted to modify one or the other of these hypotheses instead of starting anew. Many such attempts have been made in the last few years, but few have attained more than a passing notice, and none any general acceptance. One or two, however, are of considerable intrinsic interest, and may command attention for a brief period.

Ebbinghaus attempts to advance a step upon the older theories by assigning to a particular retinal substance the function of color-stimulus. He finds this substance in the so-called visual purple, which was studied with great care by Kühne more than twenty years ago. This remarkable substance is reddish purple in its normal condition. On exposure to light it bleaches rapidly, passing through a series of tints until it becomes yellow. On further exposure to light it becomes colorless, but in the dark regains its original purplish tone directly without passing again through the series of changes in color. The color-stimulus is ascribed by Ebbinghaus to the absorption of light by the visual purple, and the character of the light-sensation is directly dependent on the color of the light absorbed, that is, upon the physical properties of the substance.

The purple substance, which is changed by the action of light into the 'visual yellow,' is identified by Ebbinghaus, in its two stages, with the 'yellow-blue' substance of Hering. In its first stage it gives

rise to the sensation of yellow, in the second stage to that of blue. The visual purple pertains to that element of the retinal complex known as rods. These are not present in the central portion of the retina, and the visual purple is apparently absent there also. But the fovea is sensitive to blue and yellow, as also to green and red. Ebbinghaus supposes that a red-green substance exists, even in the fovea, green in its first stage, red in its second; that the yellow-blue substance exists also in the fovea, but that the two, present there in about equal quantity, and nearly complementary in color, neutralize each other, leaving the fovea colorless. A white-sensitive substance is also supposed to exist, more sensitive to light than any of the colored substances, and thus we arrive at three sets of color-processes, similar to those of Hering. The two types of color-blindness are explained by reference to the fact that there are two kinds of visual purple, found in the eyes of different animals, one more relatively red in tone, the other inclining more to violet. The red-blind are supposed to possess one of these, the green-blind the other. Certain anomalous and pathological color-sensations are supposed to be due to disturbances in the conducting nerves or the central organs, and hence need not be fitted into the scheme thus outlined.

The physiological character of this theory, as Mrs. Franklin has shown, can probably not be sustained. It is difficult to believe that such a balance between the visual purple-yellow and the supposed visual red-green could exist, in all stages of both, that they would remain always complementary, and so the latter always invisible. Yellow light, according to this theory, should be most active upon the visual purple, but, as a matter of fact, this material is bleached very slowly by sodium light, and, indeed, König has shown that its maximum absorption is not in the yellow, but in the green.

The visual purple exhibits other striking properties, of which the theory takes no account. It seems probable, on the whole, that the office of this substance is really a very different one, and that if it is concerned at all with vision it is with the sensation of white light, not colored.

The theory of Ebbinghaus, then, if we deny its connection with the visual purple, rests upon the same basis as that of Hering,—a visual substance not identified, perhaps not discoverable, but recognizable only through the precision with which it explains phenomena, and the hypothesis itself becomes in the main a modification of Hering's with the well-known pairs of photochemical substances, modified in their character so as to meet the facts more perfectly, removing some difficulties, but introducing others.

The chief advantage of the hypothesis for explanatory or speculative purposes lies in its greater freedom. The theory of Hering demands six color-processes. These are so connected together that they make not six, but three, independent variables. Ebbinghaus so constructs his substances as to leave them nearly independent, the blue, for instance, no longer serving as the antagonistic substance to the yellow, but regarded as developed out of it, and possessing specific properties of its own. Under certain conditions the color-substances are supposed to neutralize each other, as with Hering, a supposition which adds greatly to the difficulty of the hypothesis; but, in general, five independent variables are at the command of the theorist, which, it is evident, may be endowed with such various properties as to explain almost any conceivable difficulty of color-vision.

It may also be said that, with such an assortment of visual substances at command, the properties of which have at present no known chemical, physical or physiological relations, but are deduced entirely from the



sensations dependent upon them, the phenomena might probably be explained in an indefinite number of ways, and the different methods of explanation should be regarded rather as examples of ingenious speculation than as real contributions to the advancement of science.

To such a category belong many of the later theories of vision. They incline to Helmholtz or to Hering according as their point of view is chiefly physical or psychological, for the standpoint of these two theories is fundamentally different.

Helmholtz, showing that all colors can be compounded from three, and that white may be also compounded, assumes that three color-sensations are sufficient, and that white may be regarded as a compound sensation. Hering, relying more upon the direct deliverances of consciousness, denies the compound nature of the sensations of white and of yellow, whatever their physical composition may be, and says explicitly that "the entire separation of the optical nature of a light from the sensation which it arouses in us is one of the most necessary prerequisites to a clear handling of the theory of color." Along the lines of these two theories, then, new hypotheses move, and will move, since each of them stands for something real, and has its own distinct advantages.

Upon a somewhat different basis rests a theory, hardly so much of color as of light-sensation, which was hinted at by various observers, but most clearly worked out by von Kries. This supposes that we possess two entirely distinct kinds of visual apparatus, one dependent upon the cones of the retina, the other upon the rods, and the visual purple connected with them.

Max Schultze, so long ago as 1866, mainly on anatomical grounds, suggested that the rods were probably the most important organs of vision in faint light. Animals which prey by night, as cats, moles, owls,

etc., possess retinas rich in rods, but with cones either few or absent. Our own eyes perceive faint light more readily with the peripheral portions of the retina, where rods are numerous, than with the central portions, where they are few.

Helmholtz\* pointed out the fact that if the visual purple is actually connected with vision it must have to do with peripheral rather than central vision, since it is absent from the fovea, and suggested that it might have to do with the perception of faint light.

In 1894 König studied the absorption curve of the visual purple, finding it substantially identical with the curve of brightness for the spectrum of low luminosity. von Kries, combining these and other suggestions, considers the visual purple in the rods to be, in the human eye at least, the active agent for the perception of faint light. He shows that the phenomena of adaptation point in the same direction. In strong light the visual purple is soon bleached. An eye 'adapted for brightness' is very deficient in power to perceive faint light. If it is now kept in darkness for about half an hour this faculty is enormously increased. But in about the same period the visual purple is practically restored. The essence of adaptation is the recovery of the visual purple. Red light, which does not act upon this substance, does not destroy the sensitiveness to faint light in an eye which has been exposed to it for even a considerable time.

If vision by faint light depends, wholly or partly, on the decomposition of the visual purple, and if light of long wave-lengths does not effect this decomposition, blue light when faint should appear much brighter than red, and Purkinje's phenomenon is thus easily explained. But in the fovea, where the rods and the purple are not present, this sensation of colorless faint light

\* *Physiol. Optik*, 2d. ed., p. 268.



should not exist, and the color of any light bright enough to affect this portion of the retina at all will at once be recognized. von Kries declares this to be a fact. Two colors, equally bright in strong light, will remain so at all illuminations if their image falls entirely on the fovea; but, if not, the color which is of the shorter wave-length will in general be the brighter.

Vision by strong light, and color-vision, since both are possessed by the fovea, must be effected by the mechanisms of that retinal area, and these sensations von Kries attributes to the cones, which are supposed to be furnished with a tri-chromatic color-apparatus, and to afford the sensations of color and a compound sensation of white. If objection is made to the compound white the details of this latter apparatus might be varied, might even approximate that of Hering's theory, without affecting the importance of the hypothesis, the essence of which is the twofold nature of the sensation of brightness.

Such a theory explains easily the fact that grays compounded from different pairs of complementary colors, and equally bright in ordinary light, cease to be so in faint light. They are equalized at first by the cone-apparatus, and are seen in the faint light chiefly by the rod-apparatus, in which the scale of brightness is entirely different.

G. E. Müller makes the acute suggestion that the visual purple may not be a visual substance at all, properly speaking; but, while concerned chiefly with the phenomena of adaptation, may act also as a *sensibilisator*—to borrow a photographic term—for the white-sensitive substance, increasing its susceptibility in faint light. This modification of von Kries' hypothesis is perhaps simpler than the original and equally satisfactory.

Still another hypothesis for separating the white from the color-sensations is that the sensation of white, from an evolutionary

standpoint, was developed earlier than the sensations of color, and that the mechanisms of the latter are to be regarded as evolved from that of the fundamental sensation, and as modifications of it. Upon this idea Mrs. Franklin has founded her ingenious theory of light-sensation. Abney has made a similar suggestion, but in general terms only.

Such is a brief and hasty summary of the progress of color-theory. We may well ask for the result. In the general shifting, what views have maintained or gained a footing? A few, I think, are fairly well established.

1. The number of color-sensations is small, and all color-theories positing a large number are to be distrusted. If experimental work is of any value whatever, it is certain that all light-sensations, for all purposes, may be expressed by a small number of variables. The Young-Helmholtz theory demands three. Hering's requirements, as Helmholtz has shown, may be expressed in terms of three, although the number of fundamental color-sensations, using color in its ordinary sense, is four. Such theories as those of von Kries and Mrs. Franklin require four variables, such as that of Ebbinghaus five. The introduction of a much larger number is gratuitous and unnecessary.

2. Out of this number of variables at least one is to be allotted to the white-sensation, or that which is closely akin to it, the sensation of brightness. It is no longer possible to think of white entirely as a compound sensation, however it may be compounded physically. It is unnecessary to recapitulate the arguments for this statement, drawn largely from the three forms of total color-blindness.

3. White, however, can hardly be thought of as an entirely independent sensation. The phenomena of vision by faint light, the facts of peripheral vision, show that, under certain circumstances, color-sensations contribute their quota to the colorless one, and in differing amounts at differing brightness.

These phenomena are not satisfactorily handled by any of the principal theories. They are fairly well explained by the Helmholtz suggestion of shifting color-curves, nearly as well by the hypothesis of Hering and Hillebrand, that color-sensations possess specific brightening or darkening power, which makes itself more notable as the intensity increases. These are but formal explanations, however, and increase rather than diminish the difficulties of the theories to which they are attached.

4. The theory of von Kries, of different visual mechanisms for bright and faint light, supplements excellently the existing theories, and must be regarded as a distinct step in advance.

5. A definite and highly probable function has been assigned to the visual purple, the function of adaptation, and of causing or aiding vision in faint light.

Farther than these at present we can hardly go. The number and variety of known phenomena are great and constantly increasing. Their inter-relations grow every day more complex, and the actual mechanism governing those relations still remains almost entirely unknown. Subjective experiment appears likely to yield little more aid. The various theories have arrived at such a state of perfection, and, thanks to subsidiary hypothesis, to such a state of flexibility, that almost any visual result might probably be explainable by either. Perhaps the most hopeful line of research is that which, like König's study of the visual purple, seeks to find some relation between color-sensations and physical properties. Since so many phenomena point to photo-chemical changes in the eye, it would not be surprising if the next advance should come from the chemical side, rather than from the physiological, physical or psychological, which have held the field so long.

FRANK P. WHITMAN.

ADELBERT COLLEGE.

*A HALF-CENTURY OF EVOLUTION, WITH SPECIAL REFERENCE TO THE EFFECTS OF GEOLOGICAL CHANGES ON ANIMAL LIFE (III).\**

4. THE UPPER CRETACEOUS REVOLUTION.

ANOTHER profound and epoch-making change occurred at the beginning of the Upper Cretaceous. In Eurasia, as Kayser states, "this was one of the greatest changes in the distribution of land and water over almost the whole earth that is known in geographical history. Extensive areas which had for long periods been continents were now overflowed by the sea and covered with Cretaceous deposits;" the Upper Cretaceous strata in certain areas in Germany and Belgium resting directly on archean rocks. In America (the Dakota stage) there was also a great subsidence. The Atlantic coastal plain was submerged over what was Triassic soil, also the lowlands from New Jersey through Maryland to Florida, while the Gulf of Mexico extended northward and covered western Tennessee, Kentucky and southern Illinois; a wide sea connected the Gulf of Mexico with the Arctic Ocean, and thus the North America of that time was divided into a Pacific and an Atlantic land, the latter comprising the Precambrian and Paleozoic areas.

As Scott states: "The Appalachian mountains, which had been subjected to the long-continued denudation of Triassic, Jurassic and Lower Cretaceous times, were now reduced nearly to base-level, the Kitatinny plain of geographers. The peneplain was low and flat, covering the whole Appalachian region, and the only high hills upon it were the mountains of western North Carolina, then much lower than now. Across this low plain the Delaware, Susquehanna and Potomac must have held very

\* Address of the Vice-President before Section F—Zoology—of the American Association for the Advancement of Science, August, 1898; concluded from SCIENCE, September 2d. 224

much their present courses, meandering through alluvial flats" (p. 481). An elevatory movement began in the succeeding or Colorado epoch, and this was succeeded by an uplift on the Atlantic and Gulf coasts, and the continued upheaval in the interior resulted in the deposition of the Laramie brackish and fresh-water beds. There were similar widespread subsidences and upheavals in South America, the Andean chain being in large part upheaved at the close of the Cretaceous.

In the Cretaceous period there were such differences in the distribution of the fossils as to lead Römer, from his explorations in Texas as early as 1852, to consider that the resemblance of the fossils of Texas, Alabama and Mexico, with the West Indies and Colombia, to those of southern Europe were due to differences of climate, a view reiterated by Kayser (p. 283). Scott also states that the Lower Cretaceous beds of Texas show faunal resemblances which ally them to the Portugal and Mediterranean beds, while the faunal relations of South American Lower Cretaceous strata are closely like those of northern and western Africa.

The biological changes at the beginning of the Upper Cretaceous were correspondingly notable. Vast forests of conifers, palms, and especially of deciduous trees, such as the oak, sassafras, poplar, willow, maple, elm, beech, chestnut and many others, clothed the uplands, while in the jungles, on the plains and in the openings of the forests gay flowers bloomed. The flora must even then have been, comparatively speaking, one of long existence, because highly differentiated composite plants, like the sun-flower, occur in the Upper Cretaceous, or Raritan clays, of the New Jersey coast. It may be imagined that, with this great advance in the vegetation, the higher flower-visiting insects must have correspondingly multiplied in number and variety.

While the changes of level did not affect the abysses of the sea, the topography of the shallows and coast was materially modified, and to this was perhaps largely due the extinction of the ammonites and their allies.\* It is not impossible that the uncoiling of the ammonites into forms like Scaphites, Criocerases, Heliocerases, Turrilites and Baculites were originally perhaps distortions due to physical causes somewhat similar to those which produced a loosening or uncoiling of the spire in Planorbis. These variations or distortions of the pond snail, signs of weakness, the result either of pathological conditions or of senility, were due to unfavorable changes in the environment, such as either a freshening of the

\*After preparing this address I find that Wood thirty-six years ago more fully discussed this matter and mentioned the same cause I have suggested. "This disappearance," he says, "of the Ammonitidae and preservation of the Nautilidae we may infer was due to the entire change which took place in the condition of the shores at the close of the Cretaceous period; and this change was so complete that such of the shore followers as were unable to adapt themselves to it succumbed, while the others that adapted themselves to the change altered their specific characters altogether. The Nautilidae having come into existence long prior to the introduction of the Ammonitidae, and having also survived the destruction of the latter family, must have possessed in a remarkable degree a power of adapting themselves to altered conditions." On the other hand, the dibranchiate cephalopods (cuttles or squids), living in deeper water, being 'ocean rangers,' were quite independent of such geographical changes. Wood then goes on to say that the disappearance of the tetrabranchiate group affords a clew to that of the Mesozoic saurians, and also of cestracion sharks, whose food probably consisted mainly of the tetrabranchiate cephalopods. "Now the disappearance of the Tetrabranchiata, of the cestracions and of the marine saurians was contemporaneous; and we can hardly refuse to admit that such a triple destruction must have arisen either from some common cause or from these forms being successively dependent for existence upon each other." He also suggests that the development of the cuttles 'has been commensurate with that of the cetacean order, of some of which they form the food.' (*Phil. Mag.*, XXIII, 1862, p. 384.)



water or some other chemical alteration in the relative amount of alkalines and salts. The changes in the ammonites, though more remarkable, are similar to the aberrations observable in the shells of the upper and later layers of the Steinheim deposits, made known to us by Hilgendorf, Sandberger, and more especially by the detailed and masterly researches of Professor Hyatt.

In this case the Miocene Tertiary *Planorbis laevis* was supposed to have been carried into a new lake, before untenanted by these shells. Although from some unknown cause the lake was unfavorable to the production of normal *laevis*, whose descendants show the results of accidents and disease, yet, owing to isolation, which prevented intercrossing with the present stock, and to the freedom from competition, the species was very prolific, and the lake became stocked with a multitude of more or less aberrant forms constituting new species. Some of them are nearly normal, with a flat spire; others are trochiform, and others entirely unwound or corkscrew-shaped. Similar aberrations occur in *Planorbis complanatus*, living in certain ponds in Belgium (Magnon); in the slightly twisted Planorbid, *Helisoma plexata* Ingersoll of St. Mary's Lake, Antelope Park, Colorado, and in the unwound forms of *Valvata* first found by Hartt in Lawlor's Lake, near St. John, New Brunswick, and described by Hyatt.\* In all these cases of parallelism or convergence the aberrations seem to have been due to some unusual condition of the water adverse to normal growth. Hence it is not impossible that the singular uncoiled or straight forms assumed by certain of the ammonites when on the verge of extinction were likewise cases of convergence and due to weakness or senility, or at least to an unusual and unfavorable condition of the seas in which they lived.

\*Annual Report of Hayden's U. S. Geol. and Geogr. Survey of the Territories.

The physical causes of extinction of the Mesozoic reptiles may also have been due to or connected with the changes of coast level, although signs of weakness and senility are exhibited by these. In the Como or Atlantosaurus beds referred by Scott to the Lower Cretaceous rather than Jurassic, the ichthyosaur (*Sauranodon natans*) was toothless, while the colossal Cretaceous pterodactyle, *Ornithostoma* (*Pteranodon*), was entirely toothless.

The colossal Pythonomorpha, offshoots of terrestrial lizards, but with paddles adapting them for marine existence, succeeded the plesiosaurs, and may have materially aided in their extinction. Hence arises the question: Did the extinction of the marine reptiles result in or contribute to the great increase of teleost fishes?

Before the dinosaurs began to die out the type in part became specialized into lizard-like tree-climbing forms and agile bird-like forms. The first birds of the Cretaceous were toothed, carinate, highly predaceous forms, with a retrogressive side-branch of the colossal *Hesperornis*, but in this case the loss of teeth was undoubtedly a gain to the type, compensation for the lack of a dental armature in the seed-eating birds being shown in the elaboration of a gizzard.

##### 5. GEOLOGICAL CHANGES IN THE TERTIARY.

Here again we have, as in former periods, a succession of earth-movements, subsidences in one region and elevations in another, though apparently more limited in extent than before, the oscillatory movements being rather confined to coastal areas, and involving adjacent shallow seas, there being frequent alternations of marine with brackish and fresh-water beds. As Kayser remarks, the Tertiary deposits "no longer extended unaltered over whole countries like those of older systems, but generally occupied only smaller basins or bay-



like areas, filled up inland seas or shallow gulfs" (p. 328). Towards the close of the Tertiary the great mountain ranges of Asia and Europe, the Alps, Pyrenees, Caucasus, Himalayas, as well as the Atlas, and the Cordillera of North and South America, were upheaved. The old Tertiary nummulitic beds were, in the western Alps, raised to a height of 11,000 feet, and the Himalayas to a horizon 16,000 feet above the sea, while there were corresponding elevations in western North America and in the Rocky Mountain region.

The evidence from fossils show, what has not been disputed, that the climatic zones were by this time established. In Europe the older Tertiary was decidedly tropical, in the Miocene subtropical, but the climate of Europe was somewhat lowered late in the Miocene, as shown by the absence of palms.\* At the end of the Tertiary, *i. e.*, during the Pliocene the earth's climate was but slightly

\*Jaeger suggests that the occurrence, in the later geological periods, of warm-blooded vertebrates, protected by feathers or hair, was due to the fact that the earth then became cooler than in the preceding ages. His explanation of the origin of feathers and hair is as follows: "If the average temperature of an animal body is considerably higher than that of the surrounding media, oscillations of these media have a stimulating effect upon the skin of the animal. This leads to a tendency to form papillary chorion (*sic*) cells, and these afterwards produce hair or feathers, which represent two of the most characteristic features of warm-blooded animals. He adds that this "stimulatory effect upon the skin can only be due to low temperatures." The body temperature of the birds and mammals being high, and the covering of the hair or feathers rendering them proof against the extremes of heat or cold, we can see that there is a coincidence between this and the fact that these classes began to increase in numbers towards the end of the Mesozoic, and especially at the opening of the Tertiary, when the climatic zones began to be established. So also in the case of whales the loss of hair is compensated for by the blubber. Why, however, feathers developed in birds, rather than hair, is a problem no one has attempted to solve, though feathers, of course, better adapt the bird to flight; no flightless birds having such well developed feathers as those capable of

warmer than at present. It should here be noticed that while Greenland, Iceland, Spitzbergen and Grinnell Land under 81° north latitude were during the late Tertiary 'abnormally warm' the Tertiary floras of northeastern Asia, including those of Kamtschatka, Amurland and Saghalien and that of Japan, 'show no sign of a similar warmth, but rather point to a climate colder than that of the present day' (Kayser, p. 354).\*

The Tertiary was apparently also a time of more or less inter-continental migrations or interchange of life-forms, which crossed the oceans over so-called continental bridges. Bering Strait was at one time such a bridge, and to explain the geographical distribution of certain forms there is thought to have been a more or less continuous land-connection between India and Africa, and between Africa and South America, and possibly in the Eocene between Australia and southwestern Asia.

However hypothetical these continental bridges may be, we do know that Central America and the Isthmus of Panama were elevated at the end of the Miocene, and that the bridge thus formed between North and South America became an avenue for the interchange of mammals and other animals which materially modified the distribution of life in the southern and northern parts of our continent.

extended flight. (See G. Jaeger, Problems of Nature, Translated by Henry G. Schlichter, D.S.C., London, 1897, p. 66.)

It might be suggested that the broad vane-like surface which characterizes feathers as compared with hairs may have been due to the fact that they would better support the body in flight; this difference from scales, as well as their greater lightness, giving this sort of armature an advantage over scales on the one hand and hairs on the other.

\*It has also been claimed by J. W. Gregory that the fossil plants of the Greenland Miocene beds may have been drifted from the southward, and that the temperature of the Polar region was not so elevated as Heer had been led to suppose. (*Nature*, Vol. 56, p. 352, 1897.)

The elevation of the West Indies took place at this date, and these islands were peopled from the South American coast. What we already know of the rapid evolution of molluscs, insects and mammals on these islands shows how closely dependent variation and adaptation are on isolation as well as changed topographic and climatic features.

These problems have been studied with great care in the Hawaiian Islands by Gulick, and more recently by Hyatt. As well stated by Woodworth: "With the development of the umbrella-shaped topography of the Island of Oahu the land shells have varied from common ancestral coastal type to valley-cradled, differentiated varieties in the upper and disjointed valleys of this dismantled, volcanic island cone."\*

The limits of this address do not permit us to treat at length of the wonderful changes, both geological and zoological, which occurred in western America during the Tertiary. They are now familiar to every one. The geological changes were very great and widespread, as shown by the elevation of the land at the close of the Miocene. Fragments of the Cretaceous seabottom, with horizontal strata, occur in the Rocky Mountains at a point about 10,000 feet above the sea. The inland Cretaceous sea was drained off and replaced by a series of fresh-water lakes, beginning with the Puerco, or the lowest Eocene, and ending with the Pliocene lakes.

The most salient biological features of the Tertiary are the apparently sudden appearance, all over the world, of placental mammals, ending, if the deposits are truly Pliocene, with the Java Pithecanthropus, and at the beginning of the Quaternary with paleolithic man.

The question here arises as to what re-

tarded the progress in the mammalian types, although small, generalized, feeble insect-eaters had originated certainly in the Triassic and probably as early as the end of the Permian. We can only account for it by the unfavorable biological environment, by the apparently overwhelming numbers of Mesozoic reptiles, adapted as they were for every variety of station and soil, whether on land, in the ocean, in the lakes and rivers, and even in the air.

When the reptiles became partly extinct a great acceleration in the evolution of mammals at once resulted. There were now upland grassy plains, bordered by extensive forests, which also clothed the highlands, and all the geographical conditions so favorable to mammalian life became pronounced after the Cretaceous seas were drained off.

In his admirable essay on the relation between base-leveling and organic evolution, which we had not read until after planning and writing this address, though following the same line of thought, Mr. J. B. Woodworth suggests that mammalian life in the Mesozoic was unfavorably affected by the peneplain and by reptilian life.

"The weak marsupials or low mammals, which appear in this country with Dromatherium in the tolerably high relief of the Trias, were apparently driven to the uplands by the more puissant and numerous reptilia of the peneplain. Their development seems also to have been retarded." Again he says: "To sum up the faunal history of the Mesozoic alone, we have seen that *pari passu* with the creation of broad lowlands there was brought on to the stage a remarkable production of reptiles, a characteristic lowland life; and we note that the humble mammalia were excluded from the peneplain or held back in their development, so far as we know them by actual remains, during this condition of

\*The Relation between Base-leveling and Organic Evolution, referring to J. T. Gulick's article in Proc. Bost. Soc. Nat. Hist., XXIV., 1870, pp. 166-7.

affairs until the very highest Cretaceous. At the close of the Mesozoic the area of the peneplain was uplifted and there came into it the new life. Not only the changed geographic conditions, but the better-fitted mammalia, also were probably factors in terminating the life of the peneplains."\*

After the placental mammals once became established, as the result of favorable geographical conditions, of migrations, isolation, and secondarily of competition, the evolution as well as the elimination of forms, as is well known, went on most rapidly. Remains of over two thousand species of extinct mammals during Tertiary times which existed in America north of Mexico have been already described, where at present there are scarcely more than three hundred. This process of specialization involved not only the lengthening of the legs, the change from plantigrade to digitigrade, and to limbs adapted for seizing and handling their prey or food, or for swimming and climbing; the reduction of digits; the evolution of armatures, protective scales, etc.; but, above all, an increase in the mental capacity of the later forms, not only of mammals, but of birds, as shown by the progressive increase in size of their brains; those of certain existing mammals being eight times as large, in proportion to the bulk of the body, as those of their early Tertiary ancestors. This, of course, means that animal shrewdness, cunning and other intellectual qualities, the result of semi-social attrition and competition, had begun to displace the partly physical factors, and in the primates these may have in the beginning led to the appearance of man, a social animal, with the power of speech, and all the intelligent moral and spiritual qualities, which perhaps primarily owe their genesis to increased brain-power.

\* *American Geologist*, Vol. XIV., Oct., 1894, pp. 208-235.

The three most specialized types of mammals below men are the horse, the bats and the whales. In the case of the bats, which appear in the Eocene, Nature's experiment with these mammalian aeronauts succeeded to the extent that they still exist in small numbers. Late in the Cretaceous, or very early in the Eocene, competition apparently forced some unknown carnivorous type to take up an aquatic life, and the great success of the incoming cetacean type, resulting in the Eocene Zeuglodonts and Miocene Squalodon, may have had an influence on the final extinction of the colossal marine reptiles.

#### 6. THE QUATERNARY PERIOD.

Coming now to the glacial epoch of the Quaternary period, we plainly see that, under the extreme conditions to which as never before, life in the northern hemisphere was exposed how intimate are the relations of geology and biology.

The rise of land at the beginning of the Quaternary, which carried the land and the life on it up into a cooler zone, with a mean temperature so low that the snows remained from century to century unmelted, forming continental glaciers, excited an immediate influence on the life. There were very soon developed a circumpolar flora and fauna, originating from the few Pliocene forms which became adapted to climatic conditions more extreme than ever before known in the world's history. While a few forms thus survived, some must have perished, though the bulk of them migrated southward.

The story told by the Port Kennedy hole, in Pennsylvania, just south of the limits of the ice sheet, is a most striking one. In that assemblage where are intermingled the bones of mammals of the Appalachian sub-province, with certain extinct forms, and those of the tapir and peccary and colossal sloths, adapted to the warmth of the Pliocene



and of the present Central American region, we can realize as never before the immediate effect of a simple though very decided change of climate on organic life.

As a result of the submergence of the land in the north Atlantic and Arctic regions during the Leda or Champlain epoch succeeding, and the consequent amelioration of the climate, there was a return of a portion of the Pliocene species to the vast area thus freed from the presence of land ice.

Another effect of change of climate due to the further upheaval, drainage and drying up of lakes and river sources in the central portions of all the continents was the destruction of forests resulting from the drying-up of the lakes and streams, the formation of vast internal desert regions, with the desert floras and fauna and saline animals peculiar to them; these are the last steps in geological history of the origination of species, and have been taken almost under the observation of man. In the origin of species adapted to desert areas and to salt lakes, *fauna relictæ* of the lakes on the elevated plains of Asia, South America, Africa, Sweden and the Great Lake region, we see that geographical isolation and the absence of competition are the primary factors in the case.

In conclusion, it is, from the nature of the case, notwithstanding the imperfection of the geological record, apparent that the fullest, most complete and convincing proof of organic evolution is derived from the past history of life, from paleontology, which involves the fact of geological succession. Looking back for half a century we see that organic evolution is a fact and is grounded and dependent on geological evolution, and the latter on cosmical evolution. Should we ever have to abandon the principle of evolution we should also have to give up the theory of gravitation, the principle of the correlation of physical forces, and also the conception of the unity of nature. All of these

principles are interdependent, and form the foundation stones of our modern science.

The rapid summary we have given of the successive changes and revolutions in the earth's history and the fact that they are accompanied or followed by the process of the extinction of the unadapted, and their replacement by the more specialized and better adapted, show that there is between these two sets of phenomena a relation of cause and effect.

Moreover, it cannot be denied that the formation of our solar system in the manner outlined by the founders of the nebular hypothesis, that the progressive changes in geology and the earth's topography, the gradual building-up or evolution of the continents, and the increasing fitness and intelligence of the life on its surface, the final outcome being man, whose physical development was practically completed at the beginning of the Quaternary period, and whose intellectual and moral improvement have, as it were, but just begun—the scientist, as such, can scarcely deny that this process of evolution, along so many lines and involving not only material but mental and moral advances, has gone on in an orderly and progressive way. The impression left on the mind is that all these changes, inorganic and organic, have been purposive rather than fortuitous, the result of the action of natural laws, impressed on matter by an Intelligence and force outside of, but yet immanent in, all things material.

With Hutton, we may say: "We have now got to the end of our reasoning; we have no data further to conclude immediately from that which actually is. But we have got enough—we have the satisfaction to find that in Nature there is wisdom, system and consistency."

Here, as men of science merely, we may pause and confess our ignorance of the first or ultimate cause of this progressive evolutionary movement pervading the material



universe and, suspending our judgment, assume an agnostic position. But the human mind, even when rigidly scientific and logical, is so constituted that few of us are satisfied to stop here. He who is most capable of daring speculation in the realm of physical or biological or philosophic thought cannot refrain from inquiring into the nature of the first or moving cause, and how the present order of things has been brought about.

As a mere working hypothesis, we are, at least many of us, compelled to assume that the present order of things, material and immaterial, is not self-evolved, but is the result of an Infinite Intelligence and Will giving the initial impulse and dominating as well as guiding and coordinating the progressive changes, whether cosmical, geological or biological. The fact of the survival of the fittest, of the extinction of the unfit, the conclusion that throughout the universe order has arisen from chaos or the undifferentiated, the specialized from the generalized, that the good and beautiful and true have in the past overcome and will continue to outweigh what is unfit and evil in matter, mind and morals, at least strongly suggests that the First Cause is not only omnipotent but all-wise and beneficent. For evolution tends to optimism. Few working biologists are pessimistic. And thus, while science as such is concerned with facts and their relations, we can at the end of this century of scientific effort affirm that it need not be, and is not, opposed to whatever is noble, exalted, hopeful and inspiring in human aspirations, or to the yearnings of the soul for a life beyond the present, for there certainly are, in the facts of the moral and spiritual evolution of our race, intimations of immortality, and suggestions, where absolute proof is naturally wanting, of a divinity that shapes the course of nature.

ALPHEUS S. PACKARD.

BROWN UNIVERSITY.

REPORTS OF COMMITTEES OF THE AMERICAN ASSOCIATION FOR THE ADVANCEMENT OF SCIENCE.

SIXTEENTH ANNUAL REPORT OF THE COMMITTEE ON INDEXING CHEMICAL LITERATURE.

THE Committee on Indexing Chemical Literature respectfully presents to the Chemical Section its sixteenth annual report, covering the twelve months ending August, 1898.

*Works Published.*

*A Bibliography of the Metals of the Platinum Group*, Platinum, Palladium, Iridium, Rhodium, Osmium, Ruthenium, 1748-1896. By JAS. LEWIS HOWE. Smithsonian Miscellaneous Collections, 1084. City of Washington, 1897. 8vo. Pp. 318.

This fine volume forms one of the most valuable and comprehensive indexes to an important field of chemical literature produced under the auspices of the Committee since its appointment in 1882. It shows on every page evidence of conscientious and critical skill; the author- and subject-indexes, with which the book concludes, are important features. Its workmanship and the method of presentation of data in type make Dr. Howe's volume a model.

*Reference to the Literature of the Sugar-Beet*, exclusive of works in foreign languages. By CLARIBEL RUTH BARNETT. U. S. Department of Agriculture. Library Bulletin, June, 1897. 4to. Pp. 9.

This carefully edited contribution to the bibliography of a subject interesting to the chemist as well as to the scientific farmer manifests the activity of the U. S. Department of Agriculture in its Library.

*A Chemical Bibliography of Morphine* 1875-1896. By H. E. BROWN, under the direction of A. B. PRESCOTT. Completed in Pharmaceutical Archives, Vol. 1, No. 3.

A supplement carries the literature through 1897. The separates contain an index of authors.

*A Bibliography of the Metallography of Iron and Steel.* By ALBERT LADD COLBY. Published in the *Metallographist*, Vol. 1, No. 2, pp. 168-178. April, 1898.

This includes 188 titles, arranged alphabetically by authors, and numbered chronologically; it is reprinted, extended and re-arranged from *The Iron Age*, January 27, 1898, by the author.

*Review and Bibliography of the Metallic Carbides.* By J. A. MATHEWS. Smithsonian Miscellaneous Collections, No. 1090. City of Washington, 1898. 8vo. Pp. 32.

Published by the Smithsonian Institution on recommendation of this Committee. Under each metal forming a carbide the author has given a brief synopsis of the chemical data with references to the literature on that subject. There is an author-index.

*A Catalogue of Scientific and Technical Periodicals 1665-1895, together with Chronological Tables and a Library Check-List.* By HENRY CARRINGTON BOLTON. Second Edition. Smithsonian Miscellaneous Collections, No. 1076. City of Washington, 1897. 8vo. Pp. 1247.

This bibliography was first issued in 1885 and the second edition has been prepared at the request of the Smithsonian Institution. It embraces periodicals in every department of pure and applied science, including, of course, chemistry and chemical technology. The Chronological Tables give the date of publication of each volume of about 550 periodicals; they enable one to ascertain the date of a given volume in a given series of a given work, or to determine the number of a volume when the date only is given. The Library Check-List shows in what American Libraries, 133 in number, complete sets of the periodicals may be found. The second edition brings the date down to 1895; its publication has been delayed by the compilation of the

Check-List. The periodicals catalogued number 8603.

*Alkaloidal Estimation:* a bibliographical index of chemical research prepared from original literature for the Committee of Revision and Publication of the Pharmacopœia of the United States of America, 1890-1900. By PAUL I. MURRILL, under the direction of ALBERT B. PRESCOTT. Ann Arbor, 1898.

A pamphlet of about sixty pages, not for sale.

*The Review of American Chemical Research*, edited by ARTHUR A. NOYES and published in the *Journal of the American Chemical Society*, completed Vol. III., in December, 1897. Two indexes, an author- and a subject-index, increase its value

Mr. E. W. Allen, Acting Director of the Office of Experiment Stations, U. S. Department of Agriculture, in reply to inquiries, sends the following communication:

"During the past year we have completed Volume IX. of the Experiment Station Record (1897-'98). This, like former volumes, contains abstracts of and references to articles on the methods and results of work in agricultural chemistry published in this country and in Europe. During the past year the review of Russian scientific periodicals has been added. About 2,000 cards of the Card Index of Experiment Station Literature have been issued during the past year, making a total of 16,000 cards in this index at present. In addition to several accounts of chemical studies of the nutrition of man, the Office has issued a 'Report of preliminary investigations on the metabolism of nitrogen and carbon in the human organism with a respiration calorimeter of special construction,' by W. O. Atwater, C. D. Woods and F. C. Benedict, the work being carried on in part by funds furnished by this Office. In this connection may also be mentioned a compila-

tion of over 400 pages of metabolism experiments in which the balance of income and outgo was determined, made by W. O. Atwater and C. F. Langworthy, and issued from this Office. The bulletin is a digest of about 3,600 experiments with man and animals in which the balance of one or more of the factors of income and outgo was determined. While this work may at first thought seem somewhat afield, it is chemical in its character as well as physiological, and has involved in some cases quite extensive chemical studies."

The 'Digest Metabolism Experiments' herein named forms Bulletin No. 45 of the Office of Experiment Stations, and constitutes a comprehensive bibliography of the subject.

The Committee chronicles the publication of the following bibliographies bearing more or less on chemical researches:

*Contributions to the Bibliography of Gold.* By A. LIVERSIDGE. Australasian Association for the Advancement of Science. Brisbane, 1895. 8vo.

*Analyst (The).* The organ of the Society of Public Analysts. *General-Index* to the Proceedings of the Society of Public Analysts, Vol. I. (1876), and to the Analyst, Vols. I.-XX. (1877-1896). Compiled by J. CUTHBERT WELCH. London, 1897. 8vo. Pp. i+181.

Arranged on the dictionary plan, authors, subjects and cross-references in a single alphabet.

*Bibliographie des travaux scientifiques* (sciences mathématiques, physiques et naturelles) publiés par les Sociétés Savantes de la France. Par J. DENIKER. Tome I, part 2. Paris, 1897. 4to.

Part 1 was published in 1895. Most important for original papers published in France.

*Biographisch-Literarisches Handwörterbuch zur Geschichte der exacten Wissenschaften.* Von

J. C. POGGENDORFF. Dritter Band (die Jahre 1858 bis 1883 umfassend). Herausgegeben von B. W. Feddersen und A. J. von Oettingen. Leipzig, 1897-98. Roy 8vo.

This valuable addition to Poggendorff's well-known biographical dictionary is useful to chemists inasmuch as it gives the titles of original papers by the principal chemists of the world published during the period specified.

*Works in preparation and reports of progress.*

A subject- and author-index to the first twenty volumes of the *Journal of the American Chemical Society* is being compiled by Mr. Sohon, who expects to complete the MS. in December, 1898.

A *First Supplement to the Select Bibliography of Chemistry, 1492-1897*, by Henry Carrington Bolton, is now going through the press. It will form a volume of the Smithsonian Miscellaneous Collections of about 600 pages.

A *Second Supplement* to the same bibliography, to contain chemical dissertations only, is well advanced, about 8,000 titles being already in hand.

Dr. A. C. Langmuir reports the completion of his MS. *Index to the Literature of Zirconium*.

Dr. C. H. Jöuet reports the near completion of his *Index to the Literature of Thorium*.

Mr. George Wagner reports progress on a *Bibliography of Oxygen*.

The manuscript of an *Index to the Literature of Thallium, 1861-1896*, by Miss Martha Doan, lately of Cornell University, was submitted to the Committee through Professor L. M. Dennis, and after critical examination it has been unanimously recommended to the Smithsonian Institution for publication.

Dr. Alfred Tuckerman is engaged upon new editions of his *Indexes to the Literature of the Spectroscope*, and of *Thermodynamics*, which are to be continued to the year 1900.

He also reports progress on the *Index to the Mineral Waters of the World*, the printing of which has been delayed by mechanical difficulties.

Dr. Wilhelm P. Jorissen, of Rotterdam, has undertaken to bring down to date Professor Albert R. Leeds' *Indexes to Ozone and to Hydrogen Peroxide*, first issued in 1880, and long since out of print.

Monsieur Jules Garçon, chemical engineer (of 40 bis Rue Fabert, Paris), is about to publish an important contribution to the bibliography of technical chemistry, entitled: 'Répertoire universel de bibliographie des industries tinctoriales et des industries annexes.' It is expected to form three large volumes. In the preparation of this immense undertaking the author has examined 1,800 works and 111 sets of periodicals, the latter in 5,000 volumes, besides 7,000 other articles and documents. Subscriptions (100 francs) may be sent to the publishers, Gauthier-Villars et fils, Paris. M. Garçon is known as the author of the 'Bibliographie de la technologie chimique des fibres textiles,' Paris, 1893, noted in our Thirteenth Annual Report.

Two unfinished manuscript indexes are at the disposal of persons willing to undertake their completion: an *Index to the Literature of Carbonic Oxid*, begun by the late Professor William Ripley Nichols and continued by Professor Augustus H. Gill; and an *Index to the Literature of Milk*, begun by Professor Clement W. Andrews.

As stated in previous reports, this Committee does not attempt to prescribe a fixed plan for volunteer indexers, but leaves method and topic to be chosen by compilers; the Committee does not seek to control the productions further than to insure work of high merit and to guard the interests of the Smithsonian Institution, which has agreed to publish manuscripts endorsed by the Committee. Chemists willing to undertake the compilation of in-

dexes are requested to send their names and addresses with a memorandum of the subject chosen to the Chairman of the Committee (Cosmos Club, Washington, D. C.), who will furnish sample copies of indexes and other information.

H. CARRINGTON BOLTON, *Chairman*,  
F. W. CLARKE,  
A. R. LEEDS,  
A. B. PRESCOTT,  
ALFRED TUCKERMAN,  
H. W. WILEY, *Committee*.

#### REPORT OF THE COMMITTEE ON STANDARDS OF MEASUREMENT.

The determination of the mechanical equivalent of heat by the electrical method, as reported by Griffiths (*Phil. Trans.*, A, 1893) and by Schuster and Gannon (*Proc. Roy. Soc.*, Nov., 1894) gave a larger value than Rowland's corrected result. This fact has created a demand for the redetermination of the ampere in terms of the electrochemical equivalent of silver. At the Toronto meeting of the British Association last year a grant was made to the B. A. Committee on Electrical Measurements for the purpose of carrying out this investigation.

At the Detroit meeting of this Association the grant of \$50 previously made for the use of this Committee was made available for the past year. Though this appropriation was clearly insufficient for the purpose, it was decided that the redetermination of the ampere should be undertaken for the committee of this Association in the physical laboratory at Ann Arbor. The work has been ably carried to completion by Professor Patterson and Dr. Guthe. The details of the method will be given in a paper by Dr. Guthe before Section B.\*

The discrepancy between Griffiths' results and those of Rowland is about one part in 400 at all temperatures between 15° and 25° on the nitrogen scale. Those of

\* This paper was duly presented.—ED. SCIENCE.



Schuster and Gannon exceed Rowland's at 19.°1 on the same scale by about one part in 500 (Johns Hopkins University Circulars, June, 1898). These differences exist after the final elaborate comparison of thermometers and the reductions to the same absolute scale of temperature.

Since the electrical methods employed to determine the mechanical equivalent of heat involve either the current and the E. M. F. of the Clark cell or the square of this E. M. F., and since the E. M. F. of the Clark cell is determined by means of the silver voltameter it is evident that the current enters the final result as the square. If the discrepancy is due entirely to an error in the value of the ampere, assuming the ohm to be correct, then the ampere should be one part in 1,000 to one part in 800 larger than the present accepted value. That is, the electro-chemical equivalent of silver should be increased from Lord Rayleigh's value of 0.001118 to 0.0011191 or 0.0011194. Lord Rayleigh does not claim for his result an accuracy greater than one part in 1,000.

The method used by Patterson and Guthe was that of a specially constructed electro-dynamometer of large dimensions, and the employment of the torque of a phosphor-bronze wire to equilibrate the countertorque due to the effort between the magnetic fields of the stationary and movable coils. This method eliminates entirely the value of gravity  $g$ . The torque of the wire was measured by observing the period of vibration of a cylindrical brass weight of known mass and dimensions when suspended by the phosphor-bronze wire. The entire success of this part of the investigation was due to the fact that the observations were made with the whole apparatus enclosed in a fairly good vacuum. Under these conditions the vibrations could be followed for hours at various intervals; the logarithmic decrement was almost entirely constant, and it was easy to obtain a curve connect-

ing temperatures and periods of vibration as a torsional pendulum. The wire was so connected to the support and to the brass cylinder that it could be transferred from the vacuum apparatus to the electro-dynamometer and back again without disconnecting it from the terminal pins. From personal inspection at the several stages of the investigation assurance can be given that the work has been most carefully executed at every point, and all known sources of error have been as completely eliminated as possible. The weights employed were compared with the standards at the U. S. Bureau of Weights and Measures in Washington; the standard of length was a half-meter bar of speculum metal made for the University of Michigan by the late Professor W. A. Rogers. The time was taken from a standard Riefler clock checked by comparison with the observatory time. The result of the investigation is that the electro-chemical equivalent of a used solution of neutral silver nitrate, fifteen parts by weight of the silver salt to eighty-five parts of distilled water, is 0.0011192 gm. per ampere per sec. This exceeds Lord Rayleigh's value by about  $\frac{1}{3}$  of one per cent. and causes the discrepancy in the mechanical equivalent of heat to disappear.

The corresponding change in the E. M. F. of the Clark cell will be from 1.4342 to 1.4327 at 15° C. A direct determination has not yet been made and this redetermination is reserved for the coming year.

Dr. Kahle has obtained for the electro-chemical equivalent of silver the value 0.0011182 (*Wied. Annal.*, Vol. 59, p. 532) by the use of an electro-dynamometer designed by von Helmholtz and a fresh solution of the salt. Pellat and Potier found the same value as that of Patterson and Guthe (*Journ. de Phys.* 9, p. 381, 1890).

HENRY S. CARHART,

*Secretary of Committee.*

ANN ARBOR, MICH., July 25, 1898.

## CURRENT NOTES ON ANTHROPOLOGY.

## INITIATION CEREMONIES IN AUSTRALIA.

THE *bora* is the ceremony in many Australian hordes by which the boy is introduced into manhood. It has been described many times, by no one more sympathetically than by Mr. A. B. Howitt, who inherited the literary talent of his distinguished parents, William and Mary Howitt.

No description of it, however, has heretofore been offered of its ceremonial as practiced on the table land of New South Wales and that neighborhood. This is presented by Mr. R. H. Mathews in the *Proceedings* of the American Philosophical Society for July, 1898 (No. 157). It there bears the name *bürbung*. He explains the ritual with much minuteness, and adds a map on which is defined the boundaries of the several districts within which each type of ceremony is in force. He adds an appendix on the *nguttan*, an abbreviated initiation rite practiced by some tribes.

## THE TARASCAN LANGUAGE.

THE language known as Tarascan is spoken by the natives of the State of Michoacan. Its words are long, vocalic and sonorous. Previous to the Conquest the Tarascans were a semi-civilized people, city-builders, agricultural and peacefully inclined.

An 'Arte' of their tongue written by Father Gilberti was printed in Mexico in 1558, and now belongs among the rarest of Americana. Dr. Nicolas Leon, formerly Director of the Michoacan Museum, has accomplished an acceptable work to students of such subjects by editing a nearly facsimile edition of it (Mexico, 1898, pp. 344). He deserves the greatest credit for its accuracy. A limited number of copies have been placed on sale with the house of Hiersemann, Leipzig.

## ANTHROPOLOGICAL PESSIMISM.

THERE has been a curious tendency dur-

ing the last decade among European anthropologists toward scientific pessimism. Numerous writers, such as Le Bon, Lapouge, Ribot, Nordau, Vierkandt, Nadailac, etc., have deplored the traits of modern culture and seen in many of them signs of degeneration. The white race is to be overwhelmed, Europe is to lose its prestige, modern society is to go to the bad. The Latin race is to fall before the Teutonic, the Teutonic before the Slavic, and so on. M. Novicou, in a book reviewed in the *Centralblatt für Anthropologie*, calls a halt to these lamentations. He argues that when racial, national and social jealousies cease, the species will be much better off; and what these scientific 'calamity howlers' are grieving about is precisely this advancement. (*L'avenir de la race blanche*, Paris, 1897.)

D. G. BRINTON.

UNIVERSITY OF PENNSYLVANIA.

## NOTES ON INORGANIC CHEMISTRY.

A RECENT number of the *Zeitschrift für physikalische Chemie* contains two interesting investigations. The influence of various vapors on the luminosity of phosphorus has been long known; as that it is non-luminous in pure oxygen unless the pressure is reduced, that turpentine destroys the luminosity, etc. Herr Centnerszwer has experimented with a large number of substances. In the case of organic compounds he finds that in homologous series the influence increases with the number of carbon atoms, and is approximately the same for isomers. It increases with double linking of carbon atoms; is little affected by replacement of hydrogen by chlorine or bromine, but largely affected by iodine substitution. No clue is suggested to the cause of the phenomena.

THE second article is by M. Tanatar on the perborates. These are formed by the electrolysis of a concentrated solution of

sodium orthoborate, and also by treating the latter salt with hydrogen peroxid. The sodium salt,  $\text{NaBO}_3, 4\text{H}_2\text{O}$ , and the ammonium salt,  $\text{NH}_4\text{BO}_3, \text{H}_2\text{O}$  were formed and while powerful oxidizing agents are quite stable. These are the only compounds of quintivalent boron known, though from the second method of formation the possibility of their constitution being  $\text{NH}_4\text{BO}_2, \text{H}_2\text{O}_2$ , and  $\text{NaBO}_2, \text{H}_2\text{O}_2, 3\text{H}_2\text{O}$  would seem not to be excluded.

MUCH discussion has been occasioned by the announcement of the discovery of new gases in the atmosphere. Professor Berthelot calls attention in the *Comptes Rendus* to the fact that the green line of krypton almost exactly coincides with the green line of the aurora spectrum, and suggests that the element should, therefore, be called eosium. Dr. Arthur Schuster in *Nature* shows the spectrum of metargon to resemble closely that of carbon plus that of cyanogen. In replying, Professor Ramsay recognizes the great similarity, but produces evidence which seems to render it very improbable that any form of carbon could be present, as the metargon spectrum remains the same in spite of every effort to remove any possible carbon present either as an element or a compound.

THE element calcium has generally been described in text-books as a yellow metal. This color is evidently due to impurities, as M. Moissan has recently obtained pure calcium, in the form of brilliant white hexagonal crystals. The crystals were obtained by dissolving the metal in liquid sodium at a low red heat and removing the sodium by means of the cautious use of absolute alcohol. Calcium can also be obtained by the electrolysis of fused calcium iodid. Each of these methods yields a metal over ninety-nine per cent. pure.

IN the *Comptes Rendus* Moissan also shows that the metal calcium burns strongly in

hydrogen forming a hydrid  $\text{CaH}_2$ , which is transparent, crystalline and stable. It is decomposed by water with great violence, hydrogen being evolved. It is not, like the corresponding hydrid of lithium, decomposed by being heated in nitrogen. In order to distil pure lithium the metal must be kept in an indifferent gas, and for this purpose hydrogen or nitrogen will not serve, as lithium combines directly with both. The only gases which would be really indifferent would be argon and helium.

ACCORDING to *Nature* the latest statistics show a total of 6,144 chemical works in Germany, employing over 125,000 persons. In the Hamburg district 4,000 are employed, as compared with 1,300 ten years ago. This shows the rapid growth of these industries in Germany in the last few years, a fact which is attracting the attention of England and other countries as well.

J. L. H.

SCIENTIFIC NOTES AND NEWS.  
COLOR-VISION.

MR. T. C. PORTER has given a communication to the Royal Society (presented by Lord Rayleigh and printed in the Proceedings, June 30) on the flicker phenomenon. He found, among other things, making use for this purpose of a cardboard disc half black and half white, viewed in the different colors of the spectrum of the second order of a Rowland's plane diffraction grating of 14,434 lines to an inch, that the greater the duration of the stimulation of the retina by the colored light the shorter the time during which it continued to be undiminished in amount, and that, with some exactness, one of these quantities is inversely proportional to the other. This inverse proportionality is known to hold between the brightness of the stimulus and its undiminished duration; it is now seen that when the brightness is constant a longer period of exposure plays the same part as a greater luminosity as regards its undiminished continuance.

IT has been shown by Professor Albertoni that there is a close relation, in the de-



velopment of animals, between the rods and the pigment of the epithelium. In some animals both are formed before birth; in others both are formed after birth; in all, the pigment gets its full intensity only after birth, and in those born blind (kittens) only some days after they open their eyes. It would be interesting to find out if kittens pass through a period during these few days after their eyes are opened, when, although they can see by daylight, they are not yet provided with night-vision. Professor Albertoni does not distinctly say that the rods are destitute of the visual purple at this time, when the pigment of the epithelium is wanting, but it is very probable that that is the case.

C. L. F.

#### EXPERIMENTS WITH KITES AT BLUE HILL OBSERVATORY.

THE world's record for high kite flight was broken on August 26th at Mr. Rotch's observatory by Messrs. Clayton and Ferguson, who dispatched a tandem of kites into the air until the highest one reached an altitude of 12,124 feet above the sea level, a height 277 feet greater than any kite has reached heretofore.

The top kite was of the Lamson ribbed pattern, and had an area of 71 square feet. The other kites were the modified Hargreave box variety, and had a combined area of 149 square feet. All the kites were fitted with self-regulating, elastic bridles, invented at the observatory, to prevent the kites from exerting a dangerous pull. Five miles of line, weighing 75 pounds, was let out, while the weight of the kites, recording instruments and secondary line, was 37 pounds, making a total of 112 pounds lifted into the air. The recording instrument was made by Mr. Ferguson and was of aluminum, weighing three pounds, and registering temperature, pressure, humidity and wind velocity. The ascent was begun at 11 o'clock, and the highest point reached at 4:15 p. m.

The kites passed through clouds when about a mile above the surface of the earth, but while above the clouds the instruments showed the air to be very dry. At the highest point the temperature was 38 degrees and the wind velocity 32 miles an hour. At the ground at the

same time the temperature was 75 and the wind velocity 32 miles. The highest wind velocity recorded was 40 miles an hour at a height of 11,000 feet. The wind on the ground at this time was from the west, while at the highest point reached by the kites it was southwest. The flight was one of a series of high ascents made during the spring and summer, averaging about a mile and a-half, while on several occasions a height of over 10,000 feet has been obtained.

#### THE PREVENTION OF CONSUMPTION.

WE learn from the *British Medical Journal* that the Congress of Tuberculosis, which came to an end on August 2d, passed the following resolutions: The Congress, considering that contagion constitutes by far the most important cause of human tuberculosis, and that sputa dried and reduced to dust are the most effective agents of contagion, makes the following recommendation: 1. That, until the time arrives when tuberculosis will be included among the contagious diseases the notification of which is compulsory, all places open to the public should be provided with hygienic spittoons, and with a conspicuous notice forbidding expectoration anywhere else than into these receptacles. 2. That the public authorities set the example by ordering the carrying-out of this measure with the least possible delay in all places under their jurisdiction, and especially in schools of every class; this is the most vital point in the reform. 3. That tuberculous patients should not be sent to convalescent homes open to persons suffering from other diseases. 4. That homes should be established and specially reserved for convalescent children. 5. That a 'medical committee of initiative' for the establishment of popular and gratuitous sanatoria should be formed. 6. That the private initiative of the medical body, and the initiative of the public imitating the example already set in France and in other countries, should lead to the creation of the largest possible number of sanatoria. 7. That the Minister of Public Instruction and the Department of Public Hygiene in the Ministry of the Interior encourage, by an official patronage, the courses of instruction in hygiene which the League against Tuberculosis



is now organizing in Paris in each *arrondissement*, with the idea of extending this movement to the other towns of France. 8. That the Permanent Committee of the Congress make an official application to the general management of the Universal Exhibition of 1900 to bespeak its interest in the work of prevention of tuberculosis by studying, in conjunction with the Committee, the form in which instruction should be given to visitors to the Exhibition as to the means whereby tuberculosis is contracted and can be avoided. 9. That periodical international meetings be held for the study of tuberculosis, especially its prophylaxis. 10. That governments should endeavor to devise means of preventing or repressing the fraudulent use of tuberculin for the purpose of concealing the existence of tuberculosis in animals intended for sale or exportation. The Congress, further, considering that the constant increase of tuberculosis of bovine animals gravely threatens public health and wealth, and that contagion is the sole truly efficient cause of this increase, affirms the urgent necessity of legislative measures enjoining (a) the separation of diseased from healthy animals; (b) the prohibition of the sale of diseased animals for butcher's meat; (c) the supervision of cowhouses devoted to the production of milk intended for public use as food, and the immediate slaughter of every cow affected with tuberculous mammitis; (d) the sterilization or at least the pasteurization of milk intended for the production of butter and cheese on a large scale; (e) the generalization of the service of inspection of butcher meat on a plan more or less analogous to that which has been in operation in Belgium for several years.

## GENERAL.

PROFESSOR KOCH is at present engaged in the study of malaria in the hospitals of Milan, and expects to make a special investigation of the subject in Italy.

A DINNER, at which Lord Lister will preside, will be given to Professor Virchow on October 5th, on the occasion of his visit to London to deliver the second Huxley lecture.

THE Americans in attendance at Cambridge at the Congresses of Zoology and Physiology were Professors Bowditch and Porter, of Har-

vard; Professors Osborn and Lec, of Columbia; Professors Marsh and Lusk, of Yale; Professor Mark, of Harvard; Professor Baldwin, of Princeton; Professor Jastrow, of Wisconsin; Professor Lombard, of Michigan; Professor Watase, of Chicago; Professor Atwater, of Wesleyan, and Dr. Stiles, of the United States Department of Agriculture.

PROFESSOR WILLIAM JAMES, of Harvard University, is at present giving lectures on the Pacific Coast. These include an address before the Philosophical Union of the University of California, which, under the direction of Professor Howison, is doing much for the advancement of philosophy in America.

DR. ARNOLD GRAF, the author of valuable contributions to morphology, died in Boston on September 3d, aged thirty years. A notice of his scientific work will follow:

DR. JOHN HOPKINSON, the well-known English electrical engineer, was killed by an Alpine accident, on about August 28th. The cablegram conveying this information states that his son and two daughters were also killed, the party having apparently fallen over a precipice while ascending one of the high Alps without a guide. Dr. Hopkinson, born in 1849, was a graduate of London and Cambridge. He was elected Fellow of the Royal Society in 1878 and was elected President of the Institution of Electrical Engineers in 1890 and again in 1895. He had contributed important scientific papers to the *Transactions* of the Royal Society, but is best known for his inventions in the application of electricity. Dr. Hopkinson was intending to visit America during the coming autumn.

WE regret also to record the following further deaths among men of science abroad: Mr. J. A. R. Newlands, who in 1887 was awarded the Davy Medal of the Royal Society, in recognition of his discoveries regarding the periodic relations between the atomic weights of the elements; M. J. M. Moniz, the naturalist, who died at Madeira on July 11th, and M. Pomel, a mining engineer, who made important contributions to our knowledge of the Sahara.

WE were compelled to record some time since the regrettable fact that M. Grimaux, the eminent French chemist, had been forced to

retire from his chair in the École Polytechnique, owing to his sympathy with the protests against the scandals in the French army and courts. M. Grimaux was elected President of the French Association for the Advancement of Science two years ago, but when he attempted to deliver his address at Nantes he was interrupted by noisy demonstrations, countenanced apparently by the mayor, to such an extent that he was unable to proceed. The address was subsequently delivered in a school-house, from which the public was excluded, and M. Grimaux did not even venture to preside at the closing meeting of the Association.

THE screw schooner *Godthaab* left Copenhagen on August 16th for Angmagsalik, in East Greenland, with an expedition under First Naval Lieutenant Amdrup. The expedition, which has been fitted out by a scientific institute at a cost of 150,000 kroner, is provisioned for two years. Its object is to explore the east coast of Greenland between the 66th and 70th degree north latitude, with Angmagsalik as its starting point.

THE steam whaler *Fridtjof*, having on board Mr. Walter Wellman and the members of the expedition to Greenland, has returned to Norway after landing an expedition at Cape Tegethoff, on the southern part of Hall's Island. While the Wellman party were returning they met the expedition to Franz Josef Land under Dr. A. G. Nothorst at Koenigskar Island, and were informed that all search for Andrée had proved futile.

A NEW photographic telescope for the Cambridge Observatory is now finished at the works of Sir Howard Grubb. As the buildings are also finished, it is expected that the telescope will soon be in use.

A GRANT of £250 was made by the British government from the Royal Bounty Fund toward the expenses of the International Congress of Zoology.

It appears from a recently-issued Blue Book that the visitors to the Natural History Museum, in London, in 1897, numbered 422,607, as against 453,956 in 1886. The attendance on Sundays was well maintained, nearly 50,000 persons having, in the course of the year, availed

themselves of the privilege afforded them. The average daily attendance for the year was : For all open days (including Sundays), 1,167; for week-days only, 1,203; and for Sundays, when the Museum is open only during part of the day, 956.

IN the course of last year 26,029 volumes and pamphlets (including 124 atlases and 1,355 books of music) were added to the library of the British Museum, of which 5,962 were presented, 12,175 were received in pursuance of the laws of English copyright, 718 by colonial copyright, 480 by international exchange, and 7,594 acquired by purchase.

THE *Southern Cross*, fitted out by Sir George Newnes for Antarctic exploration under Mr. Borchgrevink, has left London for Hobart Town. The expedition, which is well equipped for scientific work, is expected to return in 1900.

THE steamship *Hope* arrived at St. Johns, N. F., on August 27th. It is reported that after leaving Sydney, C. B., the first landing was at Cape York, where Esquimaux could not be found. The expedition then sailed for Snow Pocket Bay, but here, again, they were disappointed. They then proceeded to Saunders Island, finding the natives there in poor condition. The *Hope* took on board a number of Esquimaux and sailed for Whale Sound, but owing to the heavy ice pack was unable to get in. She came out without serious injury. The party then decided to return to Saunders Island and spent a fortnight there. Then the *Hope* proceeded for Foulkefiord, meeting the *Windward* on the way. The latter is said to be a poor ship for this work, being unable to steam to any advantage. At Foulkefiord the *Hope* parted with Lieutenant Peary and sailed south on the 13th ult., the *Windward* leaving at the same time for Sheard Osborne Fiord, where Lieutenant Peary will make his headquarters during the winter.

IT will be remembered that at the time of the celebration of the centenary of the discovery of vaccination in 1896 it was decided to erect some permanent memorial to Jenner in Great Britain. The name of the British Institute of Preventive Medicine has been changed to the Jenner Institute of Preventive Medicine, and it

is proposed to collect £100,000 for the endowment of research in the Institute. The subscriptions include £5,000 from Lord Iveagh; £2,000 from the Earl of Derby; £600 from the Duke of Westminster, who, it will be remembered, assisted the Institute to obtain the site which its new building now occupies on the Chelsea Embankment; £100 from Lord Lister, and £200 from Mr. Alfred de Rothschild. Donations and subscriptions may be sent to the Honorary Treasurer of the Jenner Memorial Fund, Sir Henry E. Roscoe, 10, Bramham Gardens, London, S.W.

*Nature* states that the proposal made at the Toronto meeting of the British Association last year for a marine biological station in the Dominion of Canada is taking practical shape. Professor Prince, the Dominion Commissioner of Fisheries, reported at length upon the necessity for such a marine station for Canada in the Marine and Fisheries Blue Book, 1894; and the Royal Society, of Canada, also urged the importance of the matter; but it was not until the British Association appointed a committee, consisting of Professor E. E. Prince (Ottawa), Chairman; Professor Penhallow (Montreal), Secretary, and Professor A. B. Macallum (Toronto), Professor John Macoun (Ottawa), Professor Wesley Mills (Montreal), Professor E. W. MacBride (Montreal), and Dr. W. T. Thiselton-Dyer, that active steps were taken to carry out the scheme. An influential deputation waited upon the Hon. Sir Louis Davies, Minister of Marine and Fisheries, in April last, and during the recent sessions of the Canadian Parliament a vote of £3,000 was practically sanctioned, £1,400 being granted for the year 1898-99. A Board of Management has been chosen as follows: Professor E. E. Prince (nominated by Sir Louis Davies to represent the Department of Marine and Fisheries), to act as Director; Professors Penhallow and MacBride (McGill University), Ramsey Wright (Toronto University), L. H. Bailey (New Brunswick University), Rev. F. A. Huart (Laval University, Quebec), and members from Queen's University, Kingston, and Dalhousie University, Halifax, Nova Scotia.

It is officially announced that there were 2,300 deaths from the plague during the last

week of August in the Bombay Presidency. The epidemic is spreading, and there has been a fresh outbreak in the state of Hyderabad.

WE regret to note that the will of the late Adolph Sutro, who bequeathed valuable property in San Francisco for charitable and educational purposes, will be contested.

MESSES. D. APPLETON & Co.'s announcements for August and September include 'The Earth and Sky,' by Professor Edward S. Holden, and 'Philip's Experiments, or Physical Science at Home,' by Professor John Trowbridge, of Harvard University.

WE have received from the American Entomological Society a reprint, from the twenty-fifth volume of their *Transactions*, of the bibliographical notice of George Henry Horn, by Philip P. Calvert. A portrait of Dr. Horn forms the frontispiece of the pamphlet. There is included a chronological list of his entomological writings, compiled by Mr. Samuel Henshaw, who also contributes an index to the genera and species of Coleoptera described and named in the 265 papers.

WE learn from *Nature* that many Polish men of science have signed a protest against the action of the Prussian authorities at Posen (Poznan) in prohibiting them from attending the meeting of the Polish Association for the Promotion of Medical and Natural Knowledge, which it was proposed to hold in that town at the beginning of August. Early in July the organizing committee of the meeting was informed by the Director of Police that persons of Polish nationality would not be permitted to take part in the proceedings, and that if they went to Posen they would be expelled from the country immediately. For thirty years the Association has held its meetings without any difficulties, and in the year 1884 a meeting was held in the town of Posen itself. The recent action, directed as it was against men whose only object was calm and friendly intercourse, violates the legitimate claims of science and discourages scientific investigation in Poland. It is unfortunate that intellectual enterprise should be made to suffer on account of strained relations between certain members of German and Polish nationalities.



ties. The protest against the measures taken by the Prussian police authorities has been signed by most men of science in Cracow and Lemberg, and forwarded to the Polish members of the Austrian Parliament.

*Nature* states that efforts are being made to secure for the Maidstone Museum and Public Library the collection of prehistoric flint implements formed during the past thirty-four years by Mr. Benjamin Harrison, and illustrating important periods in the early history of man in Great Britain and elsewhere. It is proposed to select, from the specimens in Mr. Harrison's collection, the type series chosen from the chalk plateau implements by Sir Joseph Prestwich to illustrate his monographs upon the subject of plateau or eolithic implements, and other type implements which have been figured and described by other writers; a series to show variety of form and the probable uses to which these implements have been put; a collection of paleolithic implements from gravels in the West Kent district; and type series of neolithic implements found in Kent. The Maidstone Museum is situated in the immediate vicinity of the district in which they were discovered. An appeal for subscriptions to purchase the collection, signed by the Mayor of Maidstone, has been issued by the Museum Committee and nearly £100 have been subscribed.

The *British Medical Journal* states that during the first few years after the foundation of the Anticharbon Institute at Turin the number of tubes of anticharbon vaccine sent out was only 4,000 to 5,000 a year. Professor Pagliani, then Director of the Public Health, decided that the Laboratory, which had been founded at Turin by Perroncito, should be removed to Rome. Immediately after this the production of vaccine greatly increased, as it was found possible to reduce its price. In the disorganization which overtook the Department of Public Health two years ago this laboratory came to grief; fortunately, however, its work was taken up by the Sero-therapeutic Institute of Milan, from which the vaccine continues to be sent out under the supervision of Professor Airoldi, a former assistant of Perroncito. Now the

yearly output of anticharbon vaccine amounts to 165,000 tubes. From May 1, 1897, to April 30, 1898, sufficient vaccine was sent out to inoculate 33,734 bovine and 98,792 ovine animals. Anthrax has greatly diminished in Italy in recent years; but, in spite of the large amount of anticharbon serum supplied, a good many cases still occur, both among animals and among men, in different parts of the country.

THE Committee appointed by the Board of Trade, a year ago, to consider and advise upon the means of obtaining and publishing information as to opportunities for the introduction and development of British home trades in the various districts in which we have official representatives have adopted their reports. According to *Nature* it is suggested that the most economical course would be to send out experts periodically to make inquiries and to report upon the progress and the direction of trade. The Committee recommend the establishment of an office whose function it shall be to meet the constantly-increasing demand for prompt and accurate information on commercial matters, so far as it can be met by government action. Amongst the duties of this new office would be: (1) To collect and focus existing information upon any subjects of commercial interest, whether derived from official or from unofficial sources, and whether relating to British colonies or dependencies or to foreign countries. (2) To reply to inquiries which can be answered by a short note or by word of mouth, or by reference to published commercial data and statistics. (3) To direct inquirers who want special information to the proper quarter, *e. g.*, to the Commercial Department of the Foreign Office, the office of a particular colony, Chamber of Commerce, the Imperial Institute, and so forth. The proposed office would also bring together all the information contained in the diplomatic and consular reports bearing upon particular industries and the state of the market for particular classes of goods.

#### UNIVERSITY AND EDUCATIONAL NEWS.

DR. WILLIAM P. GRAHAM has been appointed associate professor of electrical engineering in Syracuse University.



At the Leland Stanford, Jr., University Mr. F. Atheling has been appointed assistant in mathematics and Mr. F. B. Baum assistant in electrical engineering.

THE corporation of Brown University will hold its annual meeting on September 8th. A successor to President Andrews will probably not be selected, but a committee will be appointed to consider the question. The report now goes that the Rev. Edward Judson, pastor of a Baptist church in New York city, is likely to be selected. The President of Brown University must be a Baptist.

MR. J. A. JOHNSTON has been appointed professor of physics and mechanics at the Royal Agricultural College at Cirencester.

DRS. LENK AND FLEISCHMANN, associate professors of mineralogy and zoology, respectively, at Erlangen, have been promoted to full professorships. Dr. Heim has been appointed professor of botany in the Agricultural College at Vienna.

#### DISCUSSION AND CORRESPONDENCE.

BASIL VALENTINE.

TO THE EDITOR OF SCIENCE: The very interesting article by Mr. C. S. Pierce in your issue of August 12th reminds me that several years ago I bought, in Brentford, England, a Latin edition of the 'Triumph-Wagen des Antimonii,' published in 1646. As Mr. Pierce makes no mention of this edition, it may possibly be worth while to call attention to it. The title-page reads as follows:

"CURRUS TRIUMPHALIS ANTIMONII: FRATRIS BASILII VALENTINI Monachi Benedictini. OPUS *Antiquioris Medicinæ & Philosophiæ Hermeticæ studiosis dicatum.* E Germanico in Latinum Versum opera, studio & sumptibus Petri Joannis Fabri Doctoris Medici Mونسпельensis. *Et notis perpetuis ad Marginem appositis ab eodem illustratum.* TOLOSÆ. Apud PETRUM BOSC, M.DC.XLVI."

Dr. Faber dedicates the book to the 'illustrissimo ac reverendissimo D.D. Carolo de Mont-chal, Archiepiscopo Tolosano Regis Christianissimi Consiliano Meritissimo.' He also contributes an introduction. "The book was the

property of one Samuel Whitlock, who has made numerous marginal notes.

"The existence of this edition, while proving nothing, appears to show that about forty years after the original publication no doubt was entertained as to the authorship of the work."

T. D. A. COCKERELL.

MESILLA PARK, NEW MEXICO, August 16th.

#### SCIENTIFIC LITERATURE.

*Fossil Plants for Students of Botany and Geology.* By A. C. SEWARD, M.A., F.G.S. With Illustrations. Vol. I. Cambridge. 1898. Pp. xviii+452. Cambridge Natural Science Manuals. Biological Series.

There has been for many years an increasing demand for a work on fossil plants that shall be at once comprehensive, scientific, and sufficiently popular for the lay student. Balfour's 'Introduction to the Study of Palæontological Botany,' Edinburgh, 1872, was too elementary, and was restricted to British material. Saporta's 'Monde des plantes avant l'apparition de l'homme,' Paris, 1879, comes nearer to the ideal, but it is now old and out of date in view of the rapid advance of the science. 'L'évolution du règne végétal,' by Saporta and Marion, in three small volumes, 1881-1885, is much more special and somewhat popular and an exceedingly suggestive work. Count Solms-Laubach's 'Einleitung in die Paläophytologie,' Leipzig, 1887, is the work of a specialist, and proceeding professedly from the botanical standpoint does not claim to cover the whole field, and is really a series of special investigations, largely confined to internal structure, and arranged in no systematic order (*e. g.*, the 'Cycadæ' are treated before the ferns, and the Calamariæ before the Lepidophytes). The English translation of this work, published four years after the German edition, contained no revision, although there had been great advance during this interval in solving the problems discussed.\* Sir William Dawson's 'Geological History of Plants,' New York, International Scientific Series, 1888, is little more than the geological history of the Devonian of Canada, although a pleasant book. The second part of Zittel's

\* See SCIENCE, Vol. XVIII., No. 464, New York, December 25, 1891, pp. 360-361.

'Handbuch der Palæontologie' is a large volume and constitutes a manual of fossil plants. It was begun by Schimper in 1879 and completed by Schenk in 1890. It treats the subject systematically and, therefore, is only adapted to the use of the advanced student or special investigator. Schenk's subsequent abridgment of this, entitled: 'Die fossilen Pflanzenreste,' Breslau, 1888, so far from popularizing it, condenses it to such a degree that it is of little use even to the latter class.

The above-named seven works, to which might, perhaps, be added the 'Sketch of Paleobotany' in the Fifth Annual Report of the U. S. Geological Survey, Washington, 1885, and the article on fossil plants in Johnson's Universal Cyclopædia (Vol. VI., pp. 639-645), constitute about the only attempts heretofore made to present a general view of the science of paleobotany without introducing descriptions of species. Potonié's 'Lehrbuch der Pflanzenpalæontologie mit besonderer Rücksicht auf die Bedürfnisse des Geologen,' begun in 1897, has now reached the third fascicle, but it bids fair to be even more technical than any of those already mentioned.

We have now before us the first volume of another comprehensive work on the general subject of fossil plants, written by one who is thoroughly equipped for his task, especially from the botanical side, and the first question that arises is as to whether it responds in any more satisfactory way than the rest to the real demand in this line, viz., the demand already mentioned for popular scientific treatment of the whole subject of extinct plant life in its relation to living plants and to geologic time. To this question the answer must be decidedly in the negative. The work fills no 'long-felt want,' and must be regarded simply as another added to the considerable number of technical treatises designed for the advanced student only. It is remarkable how, in the production of such works, the general educational requirements are ignored and only those of special research considered. The leading motive with each author seems to be to see how much better he can treat the more advanced and recondite aspects of the subject than his predecessors have done, and thus we have a multitude of very

similar works, each making a slight advance upon the preceding one.

Dismissing, then, at the outset all idea of a new departure or a fresh and novel presentation of the science of fossil plants, such as should be calculated greatly to multiply the number of persons who interest themselves in them, let us apply ourselves to the task of examining the work as it is. A criticism of a book because it is not something else can be justified in a case like the present, where there is sore need of a form of treatment which the author is fully competent to furnish and proves that he has leisure to do by making a book for which there is no special call. Still, for English readers, and especially for the very small and constantly diminishing number of students who cannot readily handle the French and German languages, the present work will be grateful and far better than a translation. Moreover, I do not hesitate to say that, aside from its being fully up to date, it is decidedly the best of the works thus far produced. Of course, this ought to be the case, not only because it is the latest, whereby all previous contributions could be laid under tribute and their defects profited by, but also because it has as its author a man with an exceptional equipment for his task, especially as not being too great a specialist, *i. e.*, not having narrowed down to any one of the main lines, as is so often the case, which gives such an uneven and one-sided character to most works of the kind.

The work is divided into two parts, the first of which is called 'General' and occupies 115 pages, while the second, or 'Systematic,' part includes the remainder of the volume and may extend through the whole of the second volume. It is, therefore, essentially a systematic work.

The 'General' part consists of a 'Historical Sketch' of 11 pages; a chapter on the 'Relation of Paleobotany to Botany and Geology,' 10 pages; one on 'Geological History,' 32 pages; one on 'The Preservation of Plants as Fossils,' 39 pages; one on 'Difficulties and Sources of Error in the Determination of Fossil Plants,' 17 pages; and one on 'Nomenclature,' 6 pages. As a book for advanced students only, the historical sketch is merely formal and as-

sumes a knowledge of all the details, but gives some references. The second short chapter is merely introductory, and the third, which is a fairly good *résumé* of the stratigraphical conditions, with a columnar section after McKenny Hughes, and a treatment of each formation in ascending order, has the defect of failing to connect the several periods closely enough with the forms of vegetation specially characterizing them. As the treatment in Part II. is botanical and not geological, this could only be done here. A fine opportunity is therefore lost.

The fourth chapter, treating of the mode of deposition of plants, is excellent and opportune, and is the best summing-up of an obscure but important subject that we have. The author seems to have realized the need of such a survey and has made it correspondingly clear that most of the popular error relating to fossils is due to ignorance of their modes of preservation in the rocks, and nothing could be more educative than a full and lucid presentation of the facts so far as known. It would be too much to expect this in a work devoted to fossil plants, but any light on the subject is valuable. Here, however, a general knowledge of geology is presupposed, and this chapter, which might well interest many geologists, is not adapted to the needs of the untrained reader.

The fifth chapter, on the difficulties to be overcome, is very cautiously written and cannot fail to exert a wholesome influence on workers in this field. It proceeds mainly from the usual standpoint of both botanists and geologists, who never tire of emphasizing the unreliability of paleobotanical data. Some excellent examples are given of the possibilities of error, and the author's modest disinclination to defend his cause seems to leave the case with the opponents of the science. This is better than an ardent defence, but he might at least have answered some of the objections that are based on ignorance of the science, and most of the cases are of this class. The errors that have been made are either due to superficial observation and poor work, or else they are committed by geologists themselves. Of this latter class are most of the instances where 'problematical organisms' coming from early formations have been referred to the plant kingdom and called

'fucoids' or 'algæ.' It is the geologists and 'paleontologists' who have done most of this, and the paleobotanists, who came later, merely found them there. They, however, are always held responsible.

As an illustration of possible carelessness on the part of paleobotanists, we may take the case mentioned by our author on page 97 of the similarity of some *Polygonums* to *Equisetum*. He says: "Without a careful examination of the insignificant scaly leaves borne at the nodes this mistake might be made." The answer is that the careful investigator would not overlook these characters, however 'insignificant.' So, too, the case of *Kaulfussia*, a fern so unlike those with which we are familiar, simply shows the necessity that the paleobotanist acquaint himself with all kinds of ferns and not be limited to those of his particular neighborhood or country.

Botanists, acquainted only with plants as they now exist, have, as a general thing, not grasped the meaning of modification with descent, although they may often borrow that phrase from Darwin and apply it in a vague sense. They, therefore, have no patience with fossil plants that differ considerably from living ones, and think it foolish to try to name and classify them. When it was discovered that *Baiera*, which had first been classed as a fern, belonged to the line of *Ginkgo*, and had to be transferred to the *Taxaceæ*, it was thought that the paleobotanists had been guilty of an egregious mistake. But now that *Ginkgo* has been found to bear antherozoids, and therefore to be much nearer to a fern than to a yew, the mistake is found to have been that of the botanists, while the paleobotanists, in referring it to the ferns, had come much nearer to truth.

In Part II. the treatment is from the lowest forms upward, but this volume closes long before the Pteridophyta, or Vascular Cryptogams, have been disposed of. In fact, only two classes of them are treated, the *Equisetales* and the *Sphenophyllales*. Over 100 pages are devoted to the *Thallophyta* and only 13 to the *Bryophyta*. Nearly all the classes are briefly treated, whether any of them have been found fossil or not. In a large number, however, fossil forms have been reported, and the field of extinct



micro-organisms is now one of the most fascinating departments of paleobotany. To mention some of these in their systematic order, we have the Coccoliths of the Lias and Cretaceous made known by Sorby and Rothpletz, though their botanical position is doubtful; the calcareous algæ (Schizophyceæ) of various seas, including our Great Salt Lake; the oolitic grains containing calcareous tubes in rocks of various ages, some of which, as, *e. g.*, *Girvanella*, have been carefully studied and are very ancient (Ordovician); numerous forms, parasitic on fossil shells and corals, which bore into or through them and have puzzled the paleontologists.

Fossil bacteria are now well recognized and go back as far as the Devonian. Doubtless they were really coeval with the primal origin of life, if they did not themselves constitute it.

The old subject of fossil algæ, or fucoids (Bilobites, Eophyton, Spirophyton, Fucoides, etc.) is disposed of very briefly. As these objects show no internal structure their true nature must remain problematical. Most of them are closely imitated by tracks made by various marine animals, and Mr. Seward seems to agree with Nathorst and others in accounting for them in this way. *Oldhamia* and *Dendrophyucus* are believed to be of mechanical origin.

Upon fossil diatoms there is now an immense literature and Mr. Seward scarcely more than refers to it. He discredits, however, entirely the claim of Castracane to have found them in the Carboniferous. They are mostly Tertiary, Pleistocene or Plankton.

Among the green algæ (Chlorophyceæ) in the family Siphonæ there occur some interesting fossil forms. We have here the rare case of a genus founded on extinct forms and subsequently discovered in the living flora. Such is the genus *Aicuntaria*. This case has the additional peculiarity that when first described by D'Archiac it was regarded as an animal. Quite a number of other genera of this group are found chiefly in the Eocene of the Paris basin, but also in older formations, *e. g.*, *Cymopolia*, *Dactylopora*, *Gyroporella*, *Sycidium* and *Vermiporella*, the last of which is Silurian. Throughout all this the general tendency has been to restore to the vegetable kingdom forms that had been regarded as animal.

Of red algæ (Floridæ, Rhodophyceæ) the principal fossil forms belong to the Nullipores, which form banks resembling coral reefs. The two best known genera are *Lithothamnion* and *Lithophyllum*. They are mostly Tertiary or Upper Cretaceous. The genus *Selenopora*, however, ranges from the Ordovician to the Jurassic.

To the brown algæ (Phæophyceæ) is referred the remarkable Prototaxites of Dawson, a land plant or tree of the Silurian and Devonian, first thought by Sir Wm. Dawson to be coniferous, as the name implies, but subsequently found to have nearly the structure of kelp, for which reason, contrary to the rules of nomenclature, Carruthers changed the name to *Nematophycus*, and still later Dawson and Penhallow proposed to call it *Nematophyton*, neither of which names can stand. Its history was popularly written by Sir William in his Geological History of Plants.

The fossil fungi are briefly treated with proper reservations and the opinion expressed that Meschinelli's list in the tenth volume of Saccardo's 'Sylloge Fungorum' 'includes certain species which are of no botanical value.\* The alleged Carboniferous fungus, *Incolaria securiformis*, described by H. Herzer from Ohio, in which the mycelia are said to be '1½ to 2 inches in diameter,' certainly did not deserve mention in such a work as this. The occurrence of fungi as diseases of fossil plants is an interesting fact and is properly dealt with.

Mr. Seward erects the Characæ into a great group or subkingdom, the Charophyta, coordinate with the Thallophyta, Bryophyta, etc. The genus *Chara* is well known in the fossil state from the occurrence of great numbers of its peculiar so-called 'fruits,' consisting of the calcareous shells enveloping the oospores which always have characteristic spiral markings. Most of them come from the Tertiary, but they are found in the Wealden and the Jurassic, and one form strongly suggesting a *Chara* was found in Devonian rocks at the Falls of the Ohio and

\*Since the appearance of Mr. Seward's volume Meschinelli has brought out a fine illustrated volume (Fungorum fossilium omnium hucusque cognitiorum Iconographia, XXXI. tabulis exornata, Vicetix, 1898), which will furnish a basis for forming a more correct judgment of his work.



named by Dr. F. H. Knowlton *Calcisphaera Lemoni*.

Both of the great families of the Bryophyta, the Hepatiere and the Musci, are found in the fossil state. Of the former the best known belong to *Marchantites* and closely resemble the common living liverwort *Marchantia*. They are found as low as the Oolite (*M. erectus* Leek-enby), but also in the Wealden and the Tertiary. For the family of mosses Mr. Seward does not even mention the numerous well authenticated forms so common in the peat bogs of Europe and in the amber, but confines himself to the ancestral types that have been called *Muscites*, one of which (*M. polytrichaceus* Renault and Zeiller) dates back to the Carboniferous. The absence of this type throughout the entire Mesozoic is doubtless accidental and will perhaps be supplied by future research. The other forms thus far known are Tertiary.

As already remarked, the present volume does not complete the great group or subkingdom of Pteridophyta, dealing only with the two classes Equisetales and Sphenophyllales, and leaving the two most important classes, Lycopodiales and Filiales, for future treatment.

The Equisetales include the fossil genera *Equisetites*, *Phyllothea*, *Schizoncurea*, *Calamites* and *Archæocalamites*. These are all very fully discussed, and although the literature is large, especially that relating to the Calamariæ, still much of the information contained in this work is either new or supported by fresh illustrations. The author follows largely the line of Williamson's work, and his conclusions can be relied upon as the last word that the science has to offer. It would be too much to follow the various steps in his reasoning, and it must suffice to point out that, while retaining the genus *Archæocalamites* of Stur from the Devonian and Lower Carboniferous (Culm), he regards these pithcasts as probably forming a transition from true *Calamites* to *Sphenophyllum*, or, rather, to use his language, "we have evidence that the *Calamites* and *Sphenophyllum* were probably descended from a common ancestral stock, and it may be that in *Archæocalamites* some of the *Sphenophyllum* characters have been retained; but there is no close affinity between the two plants."

That Mr. Seward should have erected the single fossil genus *Sphenophyllum* into a class, Sphenophyllales, coordinate with the Lycopodiales, that include the Lepidophytes and the Filiales, or ferns, may surprise some botanists, but it must be remembered that, notwithstanding a certain superficial resemblance, *Sphenophyllum* has persistently refused to identify itself with *Calamites* or *Asterophyllites*, and that from the standpoint of internal structure, so far as known, it has proved wholly unique among fossil plants.

In 1894 Messrs. Williamson and Scott, after the most prolonged investigation, declared that "the genus *Sphenophyllum* cannot be placed in any existing family of Vascular Cryptogams. Anatomically there are some striking points of resemblance to Lycopodiaceæ, but the habit and fructification are totally different from anything in that order. *Sphenophyllum*, in fact, constitutes a group by itself, which is entirely unrepresented in the present epoch, and the affinities of which cannot be determined until additional forms have been discussed."\* Mr. Seward scarcely more than iterates this view when he says that "the genus *Sphenophyllum* is placed in a special class, as representing a type which cannot be legitimately included in any of the existing groups of Vascular Cryptogams. Although this Paleozoic genus possesses points of contact with various living plants, it is generally admitted by paleobotanists that it constitutes a somewhat isolated type among the Pteridophytes of the Coal Measures. Our knowledge of the anatomy of both vegetative shoots and strobili is now fairly complete, and the facts that we possess are in favor of excluding the genus from any of the three divisions of the Pteridophyta." He then proceeds with full descriptions and excellent illustrations to work out all the characters of the genus. There is scarcely a better example of what has been called a comprehensive or prophetic type in botany, and Mr. Seward has well expressed this view in the following words: "To put the matter shortly, *Sphenophyllum* agrees with some Lycopodinous plants in its anatomical features; with the Equisetales it is connected by the verticillate disposition of the leaves, and some of the

\*Proc. Roy. Soc., London, Vol. LV., p. 124.

forms of *Sphenophyllum* strobili present features which also point to Equisetinous affinities." As to the probable derivation or genealogy of this form he quotes the Presidential address of Dr. D. H. Scott, made to the Botanical Section of the British Association in 1896, as follows: "One may hazard the guess that this interesting group may have been derived from some unknown form lying at the root of both Calamites and Lycopods. The existence of the Sphenophyllæ certainly suggests the probability of a common origin of these two series."\*

In the above hasty sketch only a few salient points have been seized merely as samples of the character of the work, and the reader must go to its well laden pages if he is to obtain any adequate idea of the wealth of information that it contains. Teachers and advanced students, or even original investigators along these lines, will await with some impatience the appearance of the second volume.

LESTER F. WARD.

WASHINGTON, D. C.

#### SCIENTIFIC JOURNALS.

THE *Astrophysical Journal* for August opens with an article on observations on stellar motions in the line of sight contributed from the Emerson McMillin Observatory by Professor H. C. Lloyd. There is an article on the concave grating by Mr. S. A. Mitchell and a number of minor contributions. The greater part of the number is, however, taken up by an article on the series spectra of oxygen and sulphur and selenium by Drs. Runge and Paschen.

THE September number of the *Educational Review* contains articles by Hugo Münsterberg on 'Psychology and Education;' Gabriel Compayré on 'Contemporary Education in France;' William T. Harris on 'The Use of Higher Education;' Charles W. Eliot on 'The Older and the Newer Colleges;' Friedrich Paulsen on 'Examinations;' Walter L. Hervey on 'What German Universities offer to American Students of Education,' and Hiram M. Stanley on 'The Teaching of Psychology.'

THE current number of the *Atlantic Monthly*

\* British Association Reports, Liverpool Meeting, 1896 (1897), p. 1006.

contains two articles of special interest to men of science. Dr. W J McGee takes the fiftieth anniversary of the American Association as the occasion for an article on the advance of science during that period, patriotically maintaining that America must be credited with one-half of its progress. Professor Simon Newcomb contributes the second installment of his 'Reminiscences of an Astronomer,' describing his astronomical work abroad and his visits to European observatories. Professor Newcomb demonstrates that scientific eminence is compatible with an admirable literary style.

THE announcement made in this JOURNAL some time since of the plan for the publication of a journal by the Illinois Hospital for the Insane has been carried into effect by the issue of the first number of a quarterly journal to which the queer name *The Psychiater* has been given. It contains four articles by members of the staff of the Hospital: 'Professional Work in Hospitals for the Insane,' by Dr. W. G. Stearns;' 'Three Cases of Brain Tumor,' by Dr. A. F. Lemcke;' 'The Early Diagnosis of Paretic Dementia,' by Dr. V. Podstata, and 'Laboratory Psychology as applied to the Study of Insanity,' by Dr. W. O. Krohn. The number extends to 66 pages; the subscription price is \$2.00 per annum.

THE *Journal of Tropical Medicine*, edited by Dr. James Cantlie and Dr. W. J. Simpson, and published by Messrs. John Bale, Sons & Danielsson, London, began publication on August 15th, and will be issued monthly hereafter. The first number is mainly occupied by the report of the proceedings of the Section of Tropical Diseases, at the annual meeting of the British Medical Association in Edinburgh.

#### NEW BOOKS.

*Lehrbuch der anorganischen Chemie.* DR. H. ERDMANN. Braunschweig, Friedrich Vieweg und Sohn. 1898. Pp. xxvi + 756. 18 Marks.  
*A Text-book of Geodetic Astronomy.* JOHN F. HAYFORD. New York, John Wiley & Sons; London, Chapman & Hall. 1898. Pp. ix + 351.

*Laboratory Directions for Beginners in Bacteriology.* VERANUS A. MOORE. Ithaca. 1898. Pp. vi + 89.

# SCIENCE

EDITORIAL COMMITTEE: S. NEWCOMB, Mathematics; R. S. WOODWARD, Mechanics; E. C. PICKERING, Astronomy; T. C. MENDEHALL, Physics; R. H. THURSTON, Engineering; IRA REMSEN, Chemistry; J. LE CONTE, Geology; W. M. DAVIS, Physiography; O. C. MARSH, Paleontology; W. K. BROOKS, C. HART MERRIAM, Zoology; S. H. SCUDDER, Entomology; C. E. BESSEY, N. L. BRITTON, Botany; HENRY F. OSBORN, General Biology; C. S. MINOT, Embryology, Histology; H. P. BOWDITCH, Physiology; J. S. BILLINGS, Hygiene; J. MCKEEN CATTELL, Psychology; DANIEL G. BRINTON, J. W. POWELL, Anthropology.

FRIDAY, SEPTEMBER 16, 1898.

THE DEVELOPMENT OF PHOTOGRAPHY IN ASTRONOMY (I).\*

## CONTENTS:

<i>The Development of Photography in Astronomy (I.):</i>	
PROFESSOR E. E. BARNARD.....	341
<i>The International Congress of Zoology.....</i>	353
<i>Third International Congress of Applied Chemistry, Vienna, 1898: DR. FERDINAND G. WIECHMANN.....</i>	360
<i>American Mathematical Society: PROFESSOR F. N. COLE.....</i>	362
<i>Boston Meeting of the National Geographic Society: W J M.....</i>	363
<i>Current Notes on Anthropology:—</i>	
<i>The Castings from Benin; Craniological Information Desired; Ethnography of the Upper Paraguay; Motives of Suicide: PROFESSOR D. G. BRINTON.....</i>	365
<i>Notes on Inorganic Chemistry: J. L. H.....</i>	366
<i>Scientific Notes and News.....</i>	367
<i>University and Educational News.....</i>	370
<i>Discussion and Correspondence:—</i>	
<i>Pre-Columbian Music Again: PROFESSOR O. T. MASON. A Curious Optical Illusion connected with an Electric Fan: DR. F. C. KENYON.....</i>	371
<i>Scientific Literature:—</i>	
<i>Barnes on Plant Life: PROFESSOR CHARLES E. BESSEY. Wagner on Grundprobleme der Naturwissenschaft: E. A. STRONG. International Catalogue of Scientific Literature: PROFESSOR D. G. BRINTON.....</i>	372
<i>Scientific Journals.....</i>	376
<i>New Books.....</i>	376

THE American Association for the Advancement of Science has now completed an existence of half a century. It has become one of the leading scientific institutions of this country. Since its organization fifty years ago the world has advanced with wonderful rapidity in all directions, and especially in the various fields of science. It is hardly too much to say that the scientific progress in the last half century far exceeds all that was done in the preceding thousand years. The life of this Association practically covers the development and comparative perfection of many of the sciences. This is especially true of the wonderful art of photography. At the beginning of the work of this Association the great discovery of making pictures by the natural light of the sun had just been made, and while it aroused a widespread interest all over the world at that time there were very few who dreamed of the great future value of photography in the arts and sciences. One of those who saw something of the future of Daguerre's discovery was the celebrated Scottish astronomer Dr. Dick, whose works on popular astronomy are still useful and delightful reading. In his 'Practical Astronomer,' published in 1845, he said:

\*Address of the Vice-President before Section A—Mathematics and Astronomy—of the American Association for the Advancement of Science, August 22, 1898.

MSS. intended for publication and books, etc., intended for review should be sent to the responsible editor, Professor J. McKeen Cattell, Garrison-on-Hudson, N. Y.



"It is not improbable, likewise, that this art (still in its infancy) when it approximates to perfection, may enable us to take representations of the sublime objects of the heavens. The sun affords sufficient light for this purpose; and there appears no insurmountable obstacle in taking, in this way, a highly magnified picture of that luminary which shall be capable of being again magnified by a powerful microscope. It is by no means improbable, from experiments that have hitherto been made, that one may obtain an accurate delineation of the lunar world from the moon herself. The plated discs prepared by Daguerre receive impressions from the action of the lunar rays to such an extent as permits the hope that photographic charts of the moon may soon be obtained; and, if so, they will excel in accuracy all the delineations of this orb that have hitherto been obtained; and, if they should bear a microscopic power, objects may be perceived on the lunar surface which have hitherto been invisible. Nor is it impossible that the planets Venus, Mars, Jupiter and Saturn may be delineated in this way, and objects discovered which cannot be described by means of the telescope. It might, perhaps, be considered as beyond the bounds of probability to expect that very distant nebulae might thus be fixed, and a delineation of these objects produced which shall be capable of being magnified by microscopes; but we ought to consider that the art is yet in its infancy, that plates of a more delicate nature than those hitherto used may yet be prepared and other properties of light may yet be discovered which shall facilitate such designs."

Had Dr. Dick lived until the present day he would be amazed to see what portions of his prediction have in a measure come true. To him the most improbable of the things he forecast for photography to accomplish was the delineation of the nebulae, and yet it is in this direction that photographic astronomy has most decidedly excelled. To use highly magnified images for photographing the details of the planets seemed to him to be among the first triumphs that were to fall to astronomical photography; yet to-day they are almost as far from realization as they were in the days when good Dr. Dick charmed his readers with vivid descriptions of the wonders of astronomy. I do not think the most active imagination could have foreseen in

Dr. Dick's day the marvellous extent to which astronomy at the close of the nineteenth century would be influenced by that light-picturing process just then being developed by Daguerre and others.

After all, however, it is easy in the case of great discoveries of this kind to predict what they will amount to. This is usually done by immensely exaggerating all their possibilities and thus, by a happy chance, hitting one or more of their realities, for strict account is usually kept only of the hits in such cases, the misses being rejected by a charitable world as a matter of no importance. We are used to wonders in these days of wonders, and have a happy habit—from frequent practice—of correctly guessing the outcome of some of the great discoveries. But when Dr. Dick wrote, these things were not so easily foreseen, for the possibilities of the sciences were not so apparent then as they are now.

So great have become the possibilities of photography in the astronomical investigations of to-day that an account in detail of its accomplishments would far exceed the limits of this paper, and for that reason I shall be forced to a brevity in dealing with this subject that must necessarily pass over many of the interesting things photography has done for astronomy in its comparatively short lifetime.

It does not come within the province of a paper of this kind to deal with the question of priority in the discovery of photography (though something might be said on that point for America), as the process interests us only in so far as its application to astronomy is concerned.

It appears that on the very first announcement of Daguerre's wonderful discovery on the 19th of August, 1839, the celebrated French astronomer Arago, who addressed the Paris Academy on the subject, quickly foresaw the great advantage it must necessarily be to the science of astronomy, espe-



cially in the faithful delineation of the surface features of the sun and the moon, for these two objects, at least, were bright enough to register themselves with the sluggish materials then in use. It is especially gratifying to Americans that the first efforts to utilize the new discovery for the benefit of astronomy were made in this country, and that Americans have always been prominently identified with the process from its very earliest conception.

Within less than one year from the announcement of Daguerre's discovery, in March of 1840, Dr. John W. Draper, of New York City, had succeeded in getting pictures of the moon which, though not very good, foreshadowed the possibilities of lunar photography. Five years later the Harvard College Observatory may be said to have commenced its remarkable career of astronomical photography, when Bond, with the aid of Messrs. Whipple and Black, of Boston, succeeded in getting still better pictures of the moon with the 15-inch refractor. These pictures, on daguerreotype plates, seem to have been fairly good, and to have shown much detail, though the telescope was wholly uncorrected for the photographic rays. They attracted a very great interest in the subject, especially in England, but the difficulties encountered led to failures generally, except in the case of De La Rue, Dancer and one or two others. To Dancer is doubtless due the earliest success in lunar photography. Excellent photographs, it is said, were made by him as early as February, 1850. In 1858 De La Rue, using a 13-inch metal speculum, without clockwork, and guiding by following a lunar crater seen through the plate, made the most important of the early efforts at lunar photography. From this time De La Rue made the best pictures of the moon until the subject was taken up again in America in 1860 by Dr. Henry Draper, son of the illustrious John W.

Draper. Like De La Rue, Dr. Draper constructed his own telescope, a 15½-inch reflector. With this instrument he secured excellent photographs of the moon, superior to any previously made, and capable of considerable enlargement. These pictures were the best taken until Lewis M. Rutherford began his remarkable work about 1865. Rutherford's work marked the most important step until then made in astronomical photography. From this time on he produced such admirable photographs of the moon that they have not been excelled until within the past few years. These were made with a refractor of 11-inches aperture which had been constructed under his immediate supervision. It was the first telescope corrected specially for the photographic rays. Some excellent lunar photographs, in the meantime, had been made with the great four-foot reflector of the Melbourne Observatory.

The completion of the Lick Observatory in 1888 marked another decided advance in the photography of the moon. The great focal length of the magnificent instrument gave an unenlarged image of the moon about six inches in diameter, which in itself was a great advantage.

The admirable lunar photographs made by MM. Loewy and Puiseux, with the equatorial coude at Paris, in the past few years have excelled anything yet made in this direction.

But what is shown by the best lunar photographs has not yet approached that which can be seen with a good telescope of very moderate size. The minute details are at present beyond the reach of photography, but its accurate location of the less difficult features is of the highest value. The greatest interest in any observation of the moon would be in any changes that might take place on its surface. It has long ago been shown that no changes on a large scale have occurred in recent times. It is, there-

fore, to the minuter details, if anywhere, that we must look for change in the moon, and these at present are much beyond the reach of the photographic plate.

The sun, from its abundance of light, offered special inducements to the early workers in photography. It would rather appear, however, that the moon had the most charm for the first photographic astronomers. This was doubtless due to the singular and wonderful wealth of detail its surface continually presented, while the sun, except for a few occasional spots, was at best only a blank surface. When carefully and conscientiously studied, however, it highly rewarded those who took up its study photographically.

The first picture of the sun seems to have been made on a daguerreotype plate by Fizeau and Foucault in 1845. During the total eclipse of the sun on July 28, 1851, a daguerreotype was secured with the Königsburg heliometer (2.4 inches in diameter and 2-foot focus) by Dr. Busch, which appears to have been the first photographic representation of the corona. It showed a considerable number of details quite close to the moon. But in the early eclipses the photographic work seems to have been mainly devoted to representations of the solar prominences, which at that time were as rarely seen as the corona itself. During the eclipse of 1869, however, Professor Himes secured a photograph which showed the brighter structure of the corona; similar pictures were also obtained during the same eclipse by Mr. Whipple, of Boston. The corona was also slightly shown on pictures made as early as 1860 by M. Serrat. None of them, however, showed more than slight traces of the corona, extending only for a few minutes of arc from the moon's limb. Nearly all the pictures seem to have been taken with an enlarging lens, which was doubtless used to get the prominences on a larger scale. Mr. Whipple, however, in

1869, did not use any primary enlargement, and this gave him a decided advantage in point of exposure time. In nearly all of these pictures the exposures, with the slowness of the then-existing plates, were evidently too short to show the corona, except perhaps in the case of Whipple, who gave 40 seconds exposure. The other observers seemed to be content with much shorter exposures.

The first really successful photographs of the corona were obtained at the eclipse of December 22, 1870, when it was shown on the plate to a distance of about half a degree from the moon's limb. This picture, made by Mr. Brothers at Syracuse, Sicily, showed a considerable amount of rich detail in the coronal structure; and the same can also be said of the photographs of this eclipse taken by Colonel Tennant and Lord Lindsay's party. These seem to have been the first pictures to really show the great value of photography for coronal delineation. The eclipse of 1871 was still more successfully photographed, and an excellent representation of the corona, full of beautiful detail, was secured.

All of these pictures were made with the wet process, for the dry plate was not successfully used until about 1876, and it was five or six years later before it became generally useful or at all reliable. For some years previous to this, photographers had been at work with varied success upon different methods of preparing and sensitizing plates that could be used dry. Indeed, at the eclipse of 1871, at Baikul, India, it appears that Mr. Cherry used a dry plate on which he exposed a number of images of the sun before totality for the orientation of the eclipse plates. It would seem that he had only two of these plates and they were both intended to be used for orientation. The second plate, however, was broken before it could be used. It is probable they were known to be less sensitive

than the wet plates, which doubtless prevented their being used for the corona.

Though the pictures of 1870 and 1871 showed the value of the photographic method, it had so far failed to show the greater and fainter extensions of the corona. In speaking of the eclipse of 1871 and the success attained by photography at that time, it is well here to mention the evil influence that the old method of drawing had upon at least one observer. A Mr. Holiday had made observations of the corona from a housetop, and thus describes the result in his report: "As soon as the eclipse was over, I came down from the roof and plunged my head into cold water, for I was violently excited, and before breakfast I had made three drawings from my memoranda." If photography has done nothing more for astronomy than to prevent occurrences of this kind it would at least deserve lasting respect from a humane point of view.

In 1878 extensive preparations were made to observe the eclipse of July 29th of that year. Photography was to play an important part, though astronomers did not rely very strongly upon it, for it appears that all were prepared to make the customary drawings of the corona, and unfortunately each person faithfully carried out that purpose. A most suggestive illustration of the uncertainty of such work is found in the large collection of drawings published in a volume issued by the United States government relating to the eclipse of 1878. An examination of these forty or fifty pictures shows that scarcely any two of them would be supposed to represent the same object, and none of them at all closely resembled the photographs. The method of free-hand drawing of the corona made under the attending conditions of a total eclipse received its death-blow at that time, for it showed the utter inability of the average astronomer to sketch or draw

under such circumstances what he really saw.

At this time the dry plate was still in its infancy, and the results with it ranged from failure up to a fair picture of the corona. The greatest extension of the corona obtained, however, seemed to be about half a degree from the moon's limb, while Professors Newcomb and Langley traced it nearly six degrees with the eye alone. The results, nevertheless, were highly important, and they demonstrated the success of photography for this class of work.

One of the cameras at this eclipse was put in charge of a private soldier, with instructions to give an exposure of 65 seconds. The instructions were faithfully carried out, but as no one had told him to draw the dark slide the plate remained unexposed.

The total eclipse of 1882 proved to be of special interest, from the fact that a small unknown comet was then in the immediate neighborhood of the sun, and was seen with the naked eye during the eclipse. The increased sensitiveness of the plates then in use secured a strong impression of this object. The known history of the comet is comprised within the few minutes of totality of that eclipse, for it was never seen afterwards.

In the eclipse of 1886 photography again held an important position. But the extremely humid climate of Granada (one of the observing stations) and the necessity of employing volunteer observers led to numerous disasters, such as the failure to get the sun's image on the sensitive plate in the most important instrument; the breaking of the polar axis just before totality in the next important instrument; the failure of an assistant to make the exposures with another until totality was all but over; the fact that two native policemen stood in front of the photometer during totality; the two weeks' delay of the steamer in getting



away from the island; the seizure of the plates by the customs officials on arrival at New York, and, after their rescue, the subsequent delay for want of time to develop the plates, until May of next year, when they had undergone decomposition, so that the results were not as good as might have been expected.

The closing of the year 1888 and the opening of 1889 brought one of the most important eclipses that had yet occurred from a photographic standpoint. Certainly no previous eclipse, nor any since, so far as that is concerned, was photographed by so many different persons, and with such a varied assortment of cameras, telescopes, etc. The path of this eclipse lay across Nevada and California, and every photographer, amateur or professional, near the line of totality took part in the work. The amateur photographers of San Francisco and Oakland banded together under the leadership of Mr. Charles Burekhalter and photographed the eclipse in a systematic manner, the result being a most excellent collection of negatives of the corona. In some of these pictures the coronal streamers were carried to a far greater extent than at any previous eclipse; especially was this so in the photographs made by two of the amateur photographers, Messrs. Lowden and Ireland. At this eclipse the lot fell to the writer to make the photographs for the Lick Observatory. But at this time the Observatory had no instruments suitable for the work. To secure as large an image as possible with the poor equipment at hand, a  $3\frac{1}{2}$ -inch visual objective by Alvan Clark was selected. This lens, after being reduced to  $1\frac{3}{4}$  inch in diameter and mounted in an oblong box fastened to a polar axis driven by the clockwork belonging to the 12-inch equatorial, was found to give a fairly good photographic image. With this and two small photographic cameras, nine negatives of the corona were secured. The best

of these was one made with the Clark visual objective. By extreme care in development, this negative not only showed the exquisite polar systems of streamers and the details of the corona close to the moon, but also carried the coronal extensions a great distance along the ecliptic. This was by far the most successful eclipse photographically of any that had yet been observed, and forever set aside as worthless the crude and wholly unreliable free-hand sketches and drawings previously depended upon.

The eclipse of December 21, 1889, was successfully photographed, among others, by Mr. Burnham and Professor Schaeberle, comprising the Lick Observatory eclipse expedition which was sent to Cayenne. It was at this eclipse that Father Perry lost his life through the trying climatic conditions. With the sickness of death upon him, this brave man, fearless in his duty, stood by his cameras and carefully carried out his program during the eclipse, only to collapse at its close and die a few days later on the vessel that was carrying him away from the fateful spot.

The eclipse of 1893 was successfully photographed in Brazil, Africa and Chile. Professor Schaeberle made arrangements for the photography of the corona on a large scale, and with his apparatus at Mina Bronces, Chile, secured a fine series of photographs with a photo-heliograph of 40-feet focus, which he mounted on a hill sloping towards the sun. The image was formed by a stationary lens five inches in diameter upon a large sensitive plate which was moved by clockwork to counteract the sun's motion during the few minutes of the eclipse. In these pictures the image of the sun was on such a large scale that the coronal details could be very accurately studied. Upon these plates Professor Schaeberle found a hazy ill-defined spot at forty minutes' distance from the sun's center. This he sub-



sequently found also on the African and Brazilian plates, taken by the English and American astronomers. This object was in motion away from the sun, as shown by the photographs, which covered an interval of 2 hours and 36 minutes of absolute time. Professor Schaeberle believes this was a comet. It is not impossible, however, that it was a mass of coronal matter moving out from the sun, such as has been shown by the spectroscope frequently to occur in the case of solar prominences. The fact that the object seemed to be connected with the sun by a coronal streamer would rather favor the explanation. The drawing given in *Astronomy and Astro-Physics*, p. 307, Vol. XIII., seems to further support this idea.

During the solar eclipse of 1896 the sky was cloudy at nearly all the stations, and especially where the most elaborate preparations had been made for photographic work. A few photographs were obtained, however, some of which, with very small lenses, showed the coronal extensions to a great length. Mr. Burckhalter, of Oakland, Cal., had arranged an ingenious device for grading the exposures of the Corona. Clouds unfortunately prevented the trial of this experiment. The most important photographic work at this eclipse was the photographing of the flash spectrum, or the momentary reversal of the Fraunhofer lines which occurs when the edge of the sun disappears behind the moon or reappears from it, and for an instant exposes the reversing layer, which was first seen by Professor Young at the eclipse of 1870. This extremely important picture was made by William Shackleton, a young Englishman, who patiently waited and watched the spectrum at the edge of the sun, and at the instant of the reversal of the lines exposed a plate which caught, for the first time, the fugitive bright lines which are only visible for about a second. This photograph was a triumph for photography, for the record

of the phenomenon now does not rest upon the authority of any hasty observations, but remains a permanently visible record.

Our record closes with the eclipse of January 22, 1898, which was photographed in India by American and English astronomers. The photograph of the flash spectrum was successfully repeated by many observers. The coronal extensions were carried to a greater extent than at any previous eclipse, by photographs secured with a very small lens by Mr. and Mrs. Maunder.

In speaking of the photography of the corona it is well to mention the extremely interesting experiments of Dr. Huggins in an endeavor some years ago to photograph it without an eclipse. By the use of absorbing media, and later with extremely short exposures, he obtained very corona-like appearances, and it is not yet certain that they were not true coronal forms. Such experiments should be tried at very high altitudes in a pure atmosphere, and it is to be hoped that these efforts will be again undertaken under more favorable conditions.

The transit of Venus across the sun's disc in 1882 was very successfully photographed, and the measures of the pictures made by the Americans has given a good redetermination of the solar parallax. A fine series of photographs of this transit with wet plates was obtained by Professor D. P. Todd at the Lick Observatory. This was six years before the completion of the Observatory.

There is no question but that Janssen, of Meudon, succeeded many years ago in making the best photographs of portions of the sun's surface that have yet been made. These pictures show the granulation of the solar surface and the details of the sun spots with admirable clearness. Janssen has always used the old wet-plate process, which seems to give the best results in solar work. The instrument with which his work is done is a very crude affair. The

lens, 5 inches in diameter, is placed in a wooden box, which is mounted on an old camera stand on rollers. It is not provided with clock work. When Janssen wishes to make a photograph of the sun he wheels this primitive affair, stained and daubed with nitrate of silver, from a shed on to a platform, elevates it towards the sun, makes an exposure with a rapidly moving slit, and secures a photograph which, so far, but few have approached in excellence. These pictures are enlarged by a secondary lens in the camera box to about twenty inches in diameter. One peculiar feature of these photographs is the frequent presence of blurred regions, in striking contrast to the generally exquisite sharpness of the granular surface. These disturbed regions are believed by Janssen to be due to actual disturbances on the sun's surface, and, therefore, to be true phenomena of the sun. I have always had the impression that these features are simply due to the presence of small areas of bad seeing which are passing at the moment of exposure; that is, they are the effects of small local disturbances in our own air, such as every visual observer is familiar with in night work. I remember having once secured a photograph of the moon with the 12-inch of the Lick Observatory which showed just such a blurred spot on its surface. This question could be easily settled with a few exposures made a minute or so apart, for if the blurred appearance repeats itself at the same point on the sun's disc, then it can not be due to local atmospheric disturbances. Doubtless M. Janssen has long ago decided this question, but, if so, it has escaped my notice.

For the first successful photographs of the sun's surface, however, we must return to America. The first pictures to show this granulation and the details of the sun spots were taken by Lewis M. Rutherford in 1870. These pictures were also made with the collodion, or wet process.

From the importance of a more thorough understanding of the effects of the sun upon the climate of the earth, daily photographs of the solar surface are made at a number of observatories, principally at Greenwich, Kew and in India. These have been kept up for a great many years. The Lick Observatory has in recent years also taken up this subject. It is scarcely probable that a single day goes by without photographs of the sun being made at some one of these observatories. Thus a valuable record is kept of the changes taking place on the solar surface. Just what effect these sun storms have upon the earth is not yet definitely understood, but there seems to be an almost certain connection between some of the solar disturbances and terrestrial magnetic storms, so that when the sun is violently agitated a corresponding disturbance of the earth's magnetism occurs. It is not yet seen just how these disturbances may affect the weather; so far the testimony seems inconclusive, and local conditions on the earth may fully compensate for any effect solar storms might have here. In the meantime the work done in this connection at Greenwich and other places will continue to grow in importance. One thing that this repeated and constant photographing of the sun has proved is the non-existence of the so-called intra-mercurial planets, which before the days of photography were so frequently seen transitting the sun, by Lescaubault and many others. No strange thing, aside from an alleged comet, which was afterwards traced to a stain on the photographic film, has been shown on any of these photographs, with the exception, perhaps, of one of the sun photographs made in India which caught a distant bird in its flight and showed clearly its head and outspread wings projected against the sun.

Just as this continuous photographing of

the sun's surface has forever disposed of the alleged frequent transits of intra-mercurial planets, so will the photographic plate finally, when it has attained more perfection in dealing with the planets, show that many of the strange features ascribed to the surfaces of some of them do not exist.

As I have said, the early photographs of eclipses seem to have been made with the sole end in view of securing pictures of the solar prominences. This was very important at first, for by the photographs it was proved that they were true solar phenomena. Possibly also in the very first photographs a picture of the corona was considered a hopeless matter on account of the lack of sensitiveness of the plates. The eclipse of 1868 is memorable for having shown Janssen and Lockyer that the visibility of the prominences did not necessarily depend upon a total eclipse of the sun. They found that by the aid of the spectroscope the prominences could be seen and studied at any time. This was an extremely important step, and placed our knowledge of the nature of the prominences upon a firm and lasting footing. The fact that these objects could be made visible with the spectroscope soon suggested to Professor Young the idea that they might also be photographed at any time; and in 1870 he made efforts to secure impressions of them upon the photographic plate, and met with partial success. To photograph successfully these objects, however, required the invention of a special instrument, for the older methods must necessarily result in failure. In observing the prominences visually with the spectroscope it is necessary to examine them through a slit which is very narrow compared with the height of the prominences. Only a small section of the prominence can, therefore, be seen at once, and to see it all the slit must be moved over the prominence. If the slit is widened more of the object is shown, but at the same

time such a flood of light is admitted that it is lost in the glare. If an instrument could be devised whereby the slit could be moved in front of a photographic plate, successively exposing to the plate all parts of the prominence, it will readily be seen that the entire image could be photographed. To do this there must be two slits moving in perfect unison—one placed across the sun in front of the grating or prism, the other in front of the photographic plate and adjusted perfectly to the spectral line of the prominence so as to exclude all light save that emitted by the prominence itself, and thus, by the gradual motion of these two slits, the entire object is successively uncovered and an exact photograph secured of it.

The solar prominences consist mainly of incandescent hydrogen and calcium. The best results are secured by calcium alone. It is curious to see photographs of the same prominence made by using the hydrogen or calcium lines independently; these pictures often differ considerably, thereby showing the peculiarity of distribution of the calcium and hydrogen in the same prominence. The two components are differentiated, and it is thus shown just what part each component takes in the composition of the prominence. To make one of these pictures takes several minutes of exposure, during which time the slits slowly travel over the region of the prominence. This extremely ingenious device owes its existence to the inventive genius of Professor Hale, who devised and built the first instrument of this kind, and secured the first actual spectroscopic photograph of the prominences. These first pictures were made in 1891. It is, therefore, now a matter of no great labor to make not only photographs of single prominences at any time, but through a further ingenious extension of the possibilities of the instrument it is made to move across the entire sun's disc, thus securing every prominence at that time visible.



By hiding the sun's image by an occulting disc in the first sweep, and then making a second similar but more rapid sweep with the sun's image uncovered, the sun itself with all its faculæ, spots, etc., is impressed in the blank space left for it, and a complete picture of the sun and all its surroundings, with the exception of the corona, is secured. This is the method employed by Professor Hale. These pictures, however, show only those features of the sun which are due to hydrogen or calcium, and the solar surface thus appears very different from the telescopic view of it. The calcium regions come out with extraordinary distinctness, so much so, indeed, as at times to obliterate completely the sun spots, which at that moment are so distinct to the eye with the same telescope. Admirable work of this kind has also been done by M. Deslandres, of the Paris Observatory, who has devised an instrument similar to that of Professor Hale.

From the first photograph of a star by Bond in 1850 to the present time, stellar photography has gradually risen to a prominence as remarkable as it is important. The real increase of importance in this work, however, has occurred within the past ten or fifteen years, since the successful introduction of the very rapid dry plate. The wet, or collodion process was poorly adapted to the photography of the stars, and of no use whatever for comets and nebulæ. As implied by the term 'wet process,' the plate must remain wet through the entire work from its first coating with collodion until its final washing as a negative. The exposure time must, therefore, be very limited. Not only was the exposure of short duration (from fifteen to twenty minutes), but the plate was very slow in its action compared with the dry plate of today. The combination of these two difficulties made it impossible to photograph anything except the brighter stars. Dr.

Gould at Cordoba managed to increase the exposure time by keeping a stream of water playing over the plate. This, however, might cause a deterioration of the film. With the inherent difficulties of the wet plate to contend with, it is little wonder that no faint stars, nebulæ or comets were photographed. Notwithstanding this, the photographs of the star clusters, etc., of the southern skies obtained, under the direction of Gould with an 11-inch photographic refractor by the wet process, were of the highest value, and showed, upon measurement, a striking agreement in accuracy with visual work. The same can be said of Mr. Rutherford's photographs of the Pleiades, Præsepe, etc., which were made prior to Dr. Gould's, and which were the first photographs of this kind. These extremely valuable photographs of Rutherford are now receiving a most thorough measurement under the careful supervision of Professor J. K. Rees, of Columbia College, where Mr. Rutherford's negatives are stored. To this institution Mr. Rutherford left his telescope and measuring instruments.

In 1857 Bond had shown, by measurement of a series of photographs of the double star Mizar, that the highest confidence could be placed in measures of star plates. This has been fully verified in late years by Gill, Elkin and others. Dr. Elkin showed, in 1889, that measures of a photograph of the Pleiades taken by Mr. Burnham, with the great telescope at Mt. Hamilton, had equal value with his heliometer measures of the same stars.

From the necessary conditions the collodion process could make no advance in stellar photography. Previous to 1876 experiments had been made to get a workable dry plate, and for the next six years more or less success had been attained in their manufacture. But the photographers themselves took hold of these plates with



much caution because of their uncertainty. By 1881 or 1882, however, they were beginning to be used and gave considerable promise of their ultimate value, as was shown by the photographs of the comet of 1881, which were made by Draper and Janssen. These were the first photographs ever made of a comet. Efforts had been made to secure pictures of Donati's comet, in 1858, but without success.

In the fall of 1882 the world was thrilled by the advent of a magnificent comet which suddenly appeared near the comet in September, and for the next four or five months delighted astronomers with the splendor of its display. Attracted by the great brilliancy of the comet, Dr. Gill, at the Cape of Good Hope, with the aid of a local photographer and his photographic lens, secured a fine series of photographs of the comet with dry plates. When these photographs reached the northern hemisphere they attracted a great deal of attention, not only on account of the comet itself, but also from the number of stars that were impressed on the plates. At this period the Henry Brothers were making a chart of the stars along the ecliptic in their search for asteroids. They had at this time reached the region of the Milky Way, and the marvellous wealth of stars they encountered upon entering the boundaries of that vast zone completely discouraged them in their endeavors to carry their charts through the rich region traversed by the ecliptic. While hesitating as to the advisability of continuing their work the photographs of the great comet came to their notice. They were struck with the great number of stars shown on these pictures along with the image of the comet. The idea at once occurred to them that they could use this wonderful process to make their charts. It was to this simple incident that the active application of the stellar photography of to-day is due. They began at once the construction, with

their own hands, of a suitable photographic telescope of  $13\frac{1}{2}$  inches' diameter for the photography of the stars. This instrument was soon finished, and the astronomical world knows to-day what wonderful results these men produced with it; the exquisite star pictures which were marvels of definition, the photographs of the nebulae, of Saturn and Jupiter, the moon, etc., were perfect revelations.

In 1859 Tempel, at Florence, Italy, had found a diffused cometary-looking nebula connected with and extending south-westerly from the star Merope, of the Pleiades. From that time on astronomers wrangled over this object, which many of them believed had no existence. One of the first things done by the Henry Brothers was to photograph the Pleiades. These pictures showed nebulous strips near Merope, and though they did not resemble any that had been drawn by the numerous observers of the Merope nebula they rather confirmed the existence of Tempel's object. Upon these plates was shown a new nebula connected with the star Maia where none was previously known. It required the most powerful of existing telescopes to verify this visually. This was finally done, however, and it then began to dawn upon astronomers what great possibilities lay in the photographic plate for the detection and study of the nebulae. It was soon seen that their light was strongly photographic; that it was really more actinic than visual. A later photograph with a longer exposure showed the Merope nebula just as the best observers had drawn it, and at the same time filled the entire group of stars with an entangling system of nebulous matter which seemed to bind together the different stars of the group with misty wreaths and streams of filmy light, nearly all of which is entirely beyond the keenest vision and the most powerful telescope. This was a revelation. The question had often been

asked whether it would ever be possible to photograph as faint a celestial body as could be seen with a powerful telescope. Here was the answer. It was not only possible to photograph some of the faintest objects seen in the telescope, but it was possible also to photograph some others which could never be seen in the sky. In one of his reports Admiral Mouchez called attention to the fact that the only way they could see the satellite of Neptune at the Paris Observatory was on the photographs made by the Henry Brothers, for they had no telescope sufficiently powerful to show it visually.

The Henrys applied themselves assiduously to celestial photography, with the most remarkable success. They led the world in this work. While they were at the height of their activity astronomers elsewhere were but beginning to awaken to the great importance of the subject. And yet there seems to have been essentially no public recognition of the work of these two men, to whom astronomy owes so much. In personal appearance and temperament they are so extremely dissimilar that one would scarcely take them to be brothers. Up to the time they began their photographic work they had between them discovered fourteen asteroids, by the slow and tedious visual process of picking them out by their motion from the countless thousands of small stars. If one examines a list of the asteroids he will be struck with the manner in which these fourteen small planets are recorded. According to this list the first one of these was discovered in 1872 by Prosper Henry, the next one by Paul Henry, and so on alternately throughout the entire fourteen until 1879, when the last one found was attributed to Paul Henry. It is a curious fact, and one which will be readily understood by all who are acquainted with the unselfish affection existing between these two brothers, that the

credit for the discovery of these fourteen minor planets is ascribed alternately to Prosper and Paul Henry. It is likely that we shall never know which brother discovered any one of these planets.

Singularly enough, the photographic plate not only did away with the necessity of making these charts by eye and hand to facilitate the discovery of asteroids, but it also did away with the necessity of the charts themselves for that purpose, for the little planet, which is moving among the stars, now registers its own discovery by leaving a short trail—its path during the exposure—on the photographic plate. The first of these photographic discoveries of asteroids was made by Dr. Max Wolf in 1892. They are now found wholesale in this manner by photography.

It was the success of the Henry Brothers' work that led to the International Astro-Photographic Congress which met at Paris in 1886. It was their work that caused this Congress to meet at Paris. The Congress adopted the Henry Brothers' lens as a model for the instruments to be used, and the work of this great undertaking was based on that of the Henry Brothers. It was stated once by Admiral Mouchez that every object glass at the Paris Observatory had either been made by the Henry Brothers or refitted by them.

Perhaps, as Dr. Dick himself thought in the early days of photography, the most unpromising subject for the photographic plate to deal with was the nebulae. Most of these objects appeared so feeble in their light that but little encouragement in that direction was offered the celestial photographer.

One of the brightest and most promising of the nebulae is that in the sword of Orion, and this was naturally one of the first of these objects to receive photographic attention. In September, 1880, Dr. Henry Draper began the photography of the nebu-

læ with this object, and succeeded, with 51 minutes' exposure, using the dry plate, in getting a good picture of the brighter portions of the nebula. This was the first nebular photograph. With 104 minutes' exposure in March, 1881, with an 11-inch refractor, he secured a still better plate, which showed stars down to the 14.7 magnitude, which were visually beyond the reach of the same telescope. But in March, 1882, he obtained the best picture of this wonderful nebula, with an exposure of 137 minutes. These pictures marked a new era in the study of the nebulae. When these results were communicated to the French Academy by Dr. Draper, Janssen took up the subject with a silver-on-glass mirror of very short focus, having the extraordinary ratio of aperture to focus of  $\frac{1}{3}$ ; the aperture being 20 inches, with a focus of 63 inches. This remarkable instrument was constructed in 1870 for the total solar eclipse of 1871. With this Janssen found it easy to photograph the brightest parts of the nebula with comparatively short exposures. This extremely powerful photographic instrument seems to have been unused for the past fifteen years; but very recently it has been brought into use again, I understand, with the most astonishing results in photographing the nebulae. Unfortunately for science, the death of Dr. Draper, in 1882, put a stop in America to the work he had inaugurated. But it was at once taken up in England by Common, who, with a three-foot reflector, attained rapid and immediate success. His photographs of the great nebula of Orion are still classic. They were a great advance over the work of Draper, for the reflector was not only a larger telescope, but was also better adapted for photographic purposes, and especially for photographing the nebulae. In January of 1883, with only 37 minutes' exposure, he secured what was by far the most striking and beautiful picture which had yet been

taken of the great nebula. These pictures greatly extended the region of nebulosity, and the delicate details were also better shown.

The writer remembers how much he was impressed a few years later with the beauty of one of Common's photographs. It created in him the first ambition to do work of this kind. Indeed, this picture, and one of a densely crowded region of a part of the constellation of Cygnus, by the Henry Brothers, first called his attention to the great value of the photographic plate for astronomical purposes. It was at this time that the writer conceived the idea of photographing the Milky Way, though the experiments were not then successful for the want of a proper instrument. The great nebula, which has always had such a fascination for astronomers, was subsequently taken up by Isaac Roberts, who, by very prolonged exposures, still further extended the nebulous region and secured very beautiful pictures of it. Among the finest photographs of this object that have been made in recent years is one taken by Dr. H. C. Wilson at Northfield, Minn., with an 8-inch photographic refractor with an exposure of nine hours. The amount and sharpness of detail shown on this beautiful photograph is very striking, and essentially embraces all that has been done on this nebula by photography up to the present time.

E. E. BARNARD.

YERKES OBSERVATORY.

(To be concluded.)

---

THE INTERNATIONAL CONGRESS OF ZOOLOGY.\*

THE Fourth International Congress of Zoology met at Cambridge on Tuesday, August 23d, and the four following days. There were about 300 members present. The attendance from America was scarcely

\* Based on reports in the London *Times*.



as large as might have been expected, especially when compared with the representation from Continental countries. The Vice-Presidents elected were Professors R. Collett, von Graaf, Haeckel, R. Hertwig, Jentink, Marsh, Milne-Edwards, Mitsukuri and Salensky.

The scientific proceedings of the Congress were opened by Sir John Lubbock's presidential address, which was delivered in the Cambridge Guildhall. In accordance with the example set by the three previous Presidents—Professor Milne-Edwards, Count Kapnist and Professor Jentink—Sir John Lubbock's address was brief. He began by reading a letter to the Congress from Sir William Flower, and expressed his deep personal regret at that gentleman's absence and his sense of the loss the Congress had thus sustained. He then proceeded to say: I am painfully conscious how inadequately I can fill Sir William Flower's place, but my shortcomings will be made up for by my colleagues, and no one could give our foreign friends a heartier or more cordial welcome than I do. The first Congress was held at Paris in 1889 and was worthily presided over by Professor Milne-Edwards, whom we have the pleasure of seeing here to-day. The second Congress was held at Moscow in 1892, under the presidency of Count Kapnist and under the special patronage of his Imperial Highness the Grand Duke Serge. The third Congress was at Leyden in 1895, under the presidency of Dr. Jentink, Director of the Royal Museum, under the patronage of the Queen-Regent. We assemble here to-day under the patronage of his Royal Highness the Prince of Wales, with the support of her Majesty's government and under the auspices of the University of Cambridge.

Such meetings are of great importance in bringing together those interested in the same science. It is a great pleasure and a great advantage to us to meet our foreign

colleagues. Moreover, it cannot be doubted that these gatherings do much to promote the progress of science. What a wonderful thing it would be for mankind if we could stop the enormous expenditure on engines for the destruction of life and property and spend the tenth, the hundredth, even the thousandth, part on scientific progress. Few people seem to realize how much science has done for man, and still fewer how much more it would do if permitted. More students would doubtless have devoted themselves to science if it were not so systematically repressed in our schools; if boys and girls were not given the impression that the field of discovery is well-nigh exhausted. We, gentlemen, know how far that is from being the case. Much of the land surface of the globe is still unexplored; the ocean is almost unknown; our collections contain thousands of new species waiting to be described; the life-histories of many of our commonest species remain to be investigated, or have only recently been discovered.

Take, for instance, the common eel. Until quite recently its life history was absolutely unknown. Aristotle pointed out that eels were neither male nor female and that their eggs were unknown. This remained true until a few years ago. No one had ever seen the egg of an eel, or a young eel less than five centimeters in length. We now know, thanks mainly to the researches of Grassi, that the parent eels go down to the sea and breed in the depths of the ocean, in water not less than 3,000 feet below the surface. There they adopt a marriage dress of silver and their eyes considerably enlarge, so as to make the most of the dim light in the ocean depths. In the same regions several small species of fishes had been regarded as a special family known as *leptocephali*. These also were never known to breed. It now appears that they are the larvæ of eels, that known



as *leptocephalus brevirostris* being the young of our common fresh-water eel. When it gets to the length of about an inch it changes into one of the tiny eels known as elvers, which swarm in thousands up our rivers. Thus the habits of the eel reverse those of the salmon. I must not, however, go into detail, but I will take one other case—the fly of the King Charles oak-apple, so familiar to every schoolboy. In this case the females are very common; the eggs were known. But no one had ever seen a male. Hartig in 1843 knew 28 species of cynips, but in 28 years' collecting had never seen a male of any of them. Adler, however, made the remarkable discovery that the galls produced by these females are quite unlike the galls from which they were themselves reared; that these galls produced flies which had been referred to a distinct genus and of which both males and females were known. Thus the gall flies from the King Charles oak-apple (which are all female) creep down and produce galls on the root of the oak, from which quite a dissimilar insect is produced, of which both sexes occur, and the female of which again produces the King Charles oak-apple. This is not the opportunity to go into details, and I merely mention this as another illustration of the surprises which await us even in the life history of our commonest species.

Many writers have attributed to animals a so-called sense of direction. I have shown that some species of ants and bees have none. Pigeons are often quoted, but the annals of pigeon-flying seem to prove the opposite. They were jumped, as it were, from one point to another. We know little about our own senses—how we see and hear, taste or smell, and naturally even less about those of other animals. They are no doubt in some cases much acuter than ours, and have different limits. Animals certainly hear sounds which are beyond the

range of our ears. I have shown that they perceive the ultraviolet rays, which are invisible to us. As white light consists of a combination of the primary colors this suggests interesting color problems. Many animals possess organs apparently of sense and richly supplied with nerves which yet appear to have no relation to any sense known to us. They perceive sounds which are inaudible to us; they see sights which are not visible to us; they, perhaps, possess sensations of which we have no conceptions. The familiar world which surrounds us must be a totally different place to other animals. To them it may be full of music which we cannot hear, of color which we cannot see, of sensations which we cannot conceive. There is still much difference of opinion as to the mental condition of animals, and some high authorities regard them as mere exquisite automata, a view to which I have never been able to reconcile myself. The relations of different classes to one another, the origin of the great groups, the past history of our own ancestors, and a hundred other problems—many of extreme practical importance—remain unsolved. We are, in fact, only on the threshold of the temple of science. As regards these profound problems animals are even more instructive than plants. Ours is, therefore, a delightful and inspiring science.

We are fortunate in meeting in the ancient University of Cambridge, a visit to which is under any circumstances delightful in itself from its historic associations, the picturesque beauty of the buildings, and as the seat of a great zoological school under our distinguished colleague Professor M. Foster.

At the close of the presidential address, which was warmly received, the Vice-Chancellor, Dr. Hill, welcomed the Congress on behalf of the University. Greetings were presented by representatives of foreign na-

tions: Professor Alphonse Milne-Edwards, Director of the Natural History Museum, for France; Professor Schulze, of Berlin, for Germany; Professor Hubrecht, of Utrecht, for Holland; Professor O. C. Marsh for the United States; Professor Salensky, of Odessa, for Russia, and Professor Mitsukuri, of Tokio, for Japan, after which Professor Newton, Chairman of the Reception Committee, acknowledged the graceful expressions of the previous speakers. He claimed that Cambridge attached more value to zoology than did any other university, and exhibited a copy of what he regarded as the first book on zoology which treated the subject in the modern spirit. It was published in 1544 by William Turner, a Fellow of Pembroke Hall.

The most important features of the scientific proceedings of the Congress were two discussions, one on the position of sponges in the animal kingdom, the other on the origin of the mammalia. The former discussion was opened by M. Ives Delage, who said he would limit his remarks to one point in the argument. The doubt as to the affinities of sponges was whether the group Spongida was to be regarded as a distinct phylum which had arisen quite independently, or whether it was only a branch of the Cœlenterate phylum. All zoologists admitted that the sponges lacked several characters found in the typical Cœlenterates, but it was disputed whether these characters necessitated the separation of two groups. The speaker believed that one of the differences was so important as to preclude the inclusion of sponges in the same group as Cœlenterata. In the sponge larva there were two types of cells—collar-cells bearing each a long whip-like flagellum and large rounded cells containing the yolk. The former occurred at the upper end of the larva, the latter at the lower end. From analogy with the Metazoa it would be expected that the lower cells

would pass inwards and form the internal element of the larva. But observation showed that the the reverse process occurred. Balfour thought it better to assume that the observers were in error rather than that such an abnormal development could occur. There was, however, now no doubt that the observers were correct, and that two layers of the blastula stage in the sponge were formed in the opposite way to that which occurred in other animals. That was to say; the layer which had the histological character of an ectoderm had the evolution of an endoderm, and the layer that histologically was an endoderm passed to the outside and acted as the surrounding ectoderm. The possibility of this reversal Professor Delage illustrated by reference to experiments on the development of larval echinoderms in which, by raising the temperature, a similar inversion of the two layers was sometimes produced. He, therefore, held that the change was actually in the position of the cells, and not that the endoderm cells had acquired the characters of ectoderm cells, and *vice versa*. He concluded that the sponges began to develop along the same line as the rest of the Metazoa, and that they separated from the main Cœlenterate branch at the stage corresponding to the blastula.

Mr. E. A. Minchin, of Oxford, remarked that it was not until nearly the middle of the present century that the investigations of Dujardin and of Dr. Dobie, of Chester, proved that sponges were animals and not plants. After this point had been settled most observers regarded the sponges as Protozoa, a view based mainly on the histological structure of tissues. When improved methods demonstrated the relations of the constituent cells this theory was discredited; Leuckart, in 1854, pointed out the sac-like form of the adult sponge, which he compared to a polype devoid of tentacles and thread-cells. Haeckel placed

this Cœlenterate theory on a sound basis by his work on the larvæ, which he described as formed of two layers, an ectoderm and an endoderm. The Cœlenterate theory, as modified by the beautiful researches of the Chairman, soon became dominant. It was based on architectural considerations, which rendered the reference of the sponges to the Protozoa impossible. But it did not equally disprove the descent of the sponges from that group. Hence two further rival views had been advanced: (1) that the sponges, though Metazoa, are not Cœlenterata; (2) that the sponges are not Metazoa at all, but have been developed independently. The speaker summarized his own researches on the development of the Ascone sponge, *Clatharina blanca*, and concluded that the evidence appeared to favor the independent descent of the sponges from the Choanoflagellata.

The general discussion was begun by Professor Hæckel, who summarized the historical progress of opinion. He still clung to the Cœlenterate theory, because he thought that the remarkable resemblance between the blastula stages of sponges and of admitted Metazoa, such as some mollusca and amphioxus, proved that the whole metazoan phylum was monophyletic in origin. Dr. Vosmaer, of Utrecht, rather regretted that he had been invited to join in the discussion, because it was very unpleasant for a specialist on a group to be forced into a confession of ignorance regarding it. All he could say was that they did not know the exact position of the sponges in the animal kingdom. Mr. Savile Kent read a statement arguing that the sponges must be the descendants of the Choanoflagellata, as the collared cells of the two groups were known in no other animals and agreed so precisely that they must be homologous. He sketched cases in which Choanoflagellata occurred as aggregates of collared cells resting on cells

without the flagella, and thus reproducing the typical structure of the walls of a sponge blastula. He urged that workers on the sponges should acquire some personal acquaintance with the Choanoflagellata. Professor Schulze closed the discussion by a few general remarks, in which he upheld the Cœlenterate view of the sponge affinities. He said all Metazoa could be divided into two sets, those with the elements arranged radially and those in which they were bilateral. He regarded the sponges as members of the former division.

On the third day a discussion on the origin of the mammalia was opened by Professor Seeley, who began by remarking that 30 years ago birds and reptiles were united together owing to the discovery of many features in the skeletons of some fossil reptiles, previously known only in birds. But since then many reptiles have been discovered of which the skeletons show characteristic mammalian features. Accordingly the anomodont reptiles of South Africa and Texas have been united with the mammals as the group Theropsida. The distinctions, based on living reptiles and mammals, on which the separation of the two classes was founded, break down when applied to the fossils. Professor Seeley compared the skeleton of the anomodonts with that of the mammals, and showed, element by element, that there is a remarkable series of resemblances in structure between them. Thus the specialization of the teeth into canines, incisors and molars, once regarded as characteristic of mammals, occurs also among reptiles; and in the genus *Diademodon* there is a beauty of differentiation which can be paralleled only by the molars of insectivores. Similarly with the limbs, that of *Theriodesmus* was thought to prove that animal to be a mammal, but it is now known to be a reptile; and all through the limbs of the anomodonts there runs a strong mammalian strain. The marsupial bones



of the pelvic arch occur in the monotremes, and there is a suggestion of their presence in the anomodonts. In the case of the skull the articulation of the lower jaw in some anomodonts approximates to that of the monotremes, while in others they resemble the marsupials and higher mammals; further the supratemporal and quadrate jugal of Labyrinthodonts may also be represented in Ornithorhynchus, as they certainly are in *Pariasaurus*. The question is complicated by the fact that the anomodonts show resemblances to more than one mammalian type. For example, the teeth of *Diademodont* resemble those of the lemurs and of the rodents; and the Theriodont and *Dicynodont* groups of the anomodonts show affinities in the two chief divisions of the mammals. Hence Professor Seeley concludes that, though the points of resemblance between the mammalian and anomodontian skeletons show the affinity of the groups, they do not render it probable that the anomodonts are the direct ancestors of the mammals, but only form a collateral line. For the common ancestor of both we must go back to the Devonian or even to the Silurian periods, and the interval between the mammals and the anomodont reptiles is now so small that there is a reasonable probability that it will be completely bridged by the discovery of further specimens.

Professor Osborn, of Columbia University, said that certain general principles were useful guides as to the probable nature of the ancestral mammal; in the present imperfect state of the paleontological record he preferred to commence by working backward from the well known comparatively recent forms. In the first place, mammals possess the power of rapid adaptation to their conditions of life. There have been four main centers of adaptive radiation, of which the best case is that of Australia, where the marsupials have acquired forms

which among placental mammals are divided between different orders. The starting point of each adaptive radiation has been a small, unspecialized land mammal. Finally, it is probable that the ancestral mammal was omnivorous. Remembering these principles we can trace the line of mammalian descent backward; it leads us to the Jurassic, when the mammals were all small and belonged to three groups—the primitive insectivores, which have been regarded as marsupials, although there is no evidence to support that view; second, the multituberculata, which are probably early monotremes; third, the marsupials. Reversing the order of inquiry, Professor Osborn then referred to the fact that in the Permian there are three groups of reptiles, one of which is surprisingly mammalian in some of its characters, and tempts us to connect the herbivorous section of anomodonts with the monotremes. He thought, however, that the many striking points of resemblance between these reptiles and mammals were due to parallelism, similar characters having been independently acquired. He agreed with Professor Seeley that the anomodonts are not the direct ancestors of mammals, but are a collateral line. He disagreed with Professor Seeley when the latter sought for a much earlier common ancestor of the mammals and the anomodonts, as the speaker believes that an undiscovered and less specialized third subgroup of anomodonts will be found to be the true ancestor of the mammals. The Chairman, however, has shown that the mammalian egg is amphibian rather than reptilian in character; and if much weight is to be laid on this point, then the mammals may have descended from some reptile which retained certain amphibian characters.

Professor Marsh expressed his belief that the solution of this problem is still in the future. He referred to his discussions of



the question with Huxley in 1876 and with Balfour in 1881, and to subsequent progress due to paleontological discoveries. But in spite of these the great gulf between the mammals and reptiles is still unbridged, and he could not agree with Professor Seeley as to the complete collapse of the distinctions. Four points still remained. Great stress had been laid on the affinities between mammals and anomodonts, as shown by the differentiation of the teeth in the latter into three types; but other reptiles, which no one would regard as allies of the mammals, have the same specialization of the teeth, such as the Patagonian crocodile, *Motosuchus*, and the dinosaur, *Ceratopsia*. Again, there was no known reptile with two occipital condyles, as in the batrachians and the mammals. Reptiles had been described with double condyles, but he had examined the specimens in question, and the condyle in each case was really single and only cordate in shape. Thirdly, the absorption of the quadrate bone in the squamosal was not conclusive, as it occurred among plesiosaurs and dinosaurs as well as anomodonts, and in each case the quadrate bone was still in existence. Finally, in reptiles the lower jaw consists of several bones and in mammals of but one. He had examined the most mammalian of the reptiles, and the sutures between the bones were still apparent. The determination of certain bones as prefrontal he thought should be received with caution. He did not expect that the ancestor of the mammals would be found among the huge anomodonts, but among smaller animals.

Professor Haeckel said that he had discussed the problem with Huxley and Lyell 32 years before, and the former then strongly held the polyphyletic origin of the placental mammals, the carnivorous and herbivorous groups having descended respectively from carnivorous and herbivor-

ous marsupials. This view was now untenable, and the speaker believed that the different series of placental mammals converge so nearly that they must all have been derived from one marsupial ancestor. Mr. Sedgwick said that embryological evidence had been referred to, but he thought it would help very little. For example, there could be no doubt that the ancestors of horses had many toes, those of snakes had limbs, and those of birds had teeth; but no trace of these conditions had been detected by embryology. If no light was thrown on such simple problems as these they had no right to expect any on more remote questions. Reference had been made to Professor Hubrecht's use of the characters of the mammalian ovum. The speaker said it must not be forgotten that in the one genus, *Peripatus*, the eggs vary more than they do in the whole of the mammals. He expected little help from paleontology, as the ancestors of nearly all existing groups lived in the pre-Cambrian period, and all traces of them had been lost. Professor Hubrecht, in closing the discussion, said, in reply to Mr. Sedgwick, that the value of embryology was destructive, not constructive. Its evidence was of value as prohibiting certain lines of speculation. He differed from his great teacher, Professor Haeckel, whose present views he thought untenable, since Hill and Semon had shown that in two genera of Australian marsupials have traces of a placenta been found, which in one case is deciduous. He predicted that one great battlefield in the future of this controversy would be over the question whether mammals had descended from oviparous ancestors.

Many important contributions were presented before the sectional meetings of the Congress, including papers by Professor Haeckel, Professor Milne-Edwards, M. Dubois, Professor Hubrecht, Professor Marsh, Professor Osborn and other leading

zoologists. Dr. Wardell Stiles, of Washington, announced that the Committee on Zoological Nomenclature, which had been appointed at Leyden, had drawn up a report. The Committee were not unanimous, and he thought it would save much time if the subject were not discussed at the present Congress. After the circulation of the Committee's proposals a more profitable discussion could be hoped for at the next Congress. Dr. Sclater, as senior member of the Committee, proposed that the report be referred back for further consideration to the Committee, with powers to add to their number. He thought this step necessary, as the last committee were not unanimous in their conclusions. The Committee had been too small. It consisted of six members, one from each of the leading nationalities, of which never more than four had met. He thought the Committee should consist of at least two representatives of each nationality. Dr. Sclater's motion was carried unanimously.

Numerous entertainments were promised, including a reception at the Cambridge Guildhall, a reception by the Master of Downing College and Mrs. Hill, and a concluding banquet at which speeches were made by Professors Möbius, Waldeyer, Blanchard, Milne-Edwards, Marsh, Osborn and Hubrecht.

Before adjournment Professor Möbius, the senior member of the German delegation, extended a formal invitation to the Congress to meet in Germany three years hence.

---

THIRD INTERNATIONAL CONGRESS OF APPLIED CHEMISTRY, VIENNA, 1898.

THE sessions of this Congress, extending through a week's time, were opened on July the 28th by a public reception held in the Aula of the University of Vienna, Austria.

The opening address was delivered by the President of the Committee on Organization, Professor Dr. von Perger, who took occasion in his remarks to refer to the importance, to the aims and the objects of Applied Chemistry.

Among the speakers who followed von Perger in addressing the assemblage were Professor A. Bauer; Director F. Strohmer, Secretary-General of the Congress; Dr. C. Lueger, burgomaster of Vienna, and Dr. Lieben, representing the Imperial Academy of Sciences.

The Austrian Ministers of State were appointed Honorary Presidents, and some of the delegates of foreign countries were honored by their election to the office of Honorary Vice-Presidents of the Congress.

After the motion made by C. Huck, Halle a. S., that the Committee of Organization be continued in office, had been unanimously adopted, Professor E. Buchner, Tübingen, delivered a most interesting lecture: Fermentation without Yeast-cells.

His exposition, freely illustrated with experiments, was followed by all present with the closest attention; all discussion of the subject was, however, deferred to a later and more opportune occasion.

This ended the morning's doings. In the afternoon organization of the various sections was speedily effected, and thereafter most of these held sessions both mornings and afternoons during continuance of the Congress.

These gatherings of the members were most truly international in their make-up. Predominating in number in most of them were naturally the Austrians, the courteous hosts of the occasion.

To select, at hap-hazard, but a few of the many who took an active part in the proceedings: Strohmer, Wolfbauer, Kutschera, Ludwig, Jolles, Stift, Heger, Murmann, Strache, Teclu, Seidel, Werber

and Schwackhöfer. Germany had among its eminent representatives A. Herzfeld, Weinstein, Beckurts, Dietrich, F. Fischer, Winkler, Caro, Vogel, von Lippmann, Le Blanc, H. Claassen, C. Huck and Holde. France counted among her deputies Moissan, Tommasi, Gallois, Dupont, Aulard, Pellet, Dehérain, Durin, Weisberg, Sailard, Carnot, Aimé, Lindet and Deutsch.

From Russia there had come Wróblewski, Slaski, Jawein and Fischmann; Greece was represented by Christomanos, of Athens; Italy by Nasini; Holland by Lobry de Bruyn, van Ekenstein and van 't Hoff; Denmark by Sörensen.

Among the Americans present were Dr. Flint, representative of the U. S. Navy; H. W. Wiley, Washington, representing the United States; Rising, California; Watts, Philadelphia; Krause, Wyatt and Wiechmann, New York.

The principal sections, twelve in number, were:

General analytical chemistry and chemical instruments.

Chemistry of food, medical and pharmaceutical chemistry.

Agricultural chemistry.

Sugar industry.

Zymology.

Oenochemistry.

Chemical industry of inorganic substances.

Metallurgy, Explosives.

Chemical industry of organic substances.

Chemistry of the graphic industry.

Questions of instruction and general affairs of chemistry.

Electrochemistry.

A list of the papers presented and of the discussions held would not be in place here. Many of the European technical journals are giving accounts of the proceedings. The German *Chemiker-Zeitung*, for instance, is publishing valuable abstracts of the papers offered, and reference to its files is advised, pending issue of the complete

transactions, promised at the hand of the Secretary-General.

The social features of the meeting were by no means overlooked. An informal evening reception preceded the formal opening of the Congress, previously referred to. A public reception and lunch were given at the *Rathhaus* (City Hall) of the city, by its burgomaster, Dr. Lueger. This gathering was largely attended by the members of the Congress and their ladies.

Several excursions to neighboring places of interest had been arranged; social meetings were held at various places of amusement, and private banquets were held, to which some of our countrymen were bidden a cordial welcome.

The last meeting of the Congress took place August the second, again in the Aula of the University.

Director F. Strohmer, to whose care and efforts the brilliantly successful outcome of the Congress must, in great measure, be credited, took this opportunity to make his report on the work done and the results achieved. He and his able assistants were certainly fully deserving of the gratitude and the appreciation extended to them for their efforts by the grateful members of the Congress.

The next International Congress of Applied Chemistry will take place in Paris two years hence, and Professor Moissan has been charged with the selection of the French Committee of Organization.

It was thought taken of the Grand Exposition to be held in Paris in 1900 that decided the majority of members to cast their vote in favor of Paris in preference to Berlin, although this city also presented strong claims and petitions for the coveted honor of having the coming Congress take place within its walls.

May the day be not far distant when it shall be the pleasure and the good fortune of the United States to welcome to her



shores those men of all nations whose names stand for progress and advance in Applied Chemistry, that branch of our noble science to which America owes no small share of her magnificent development and prosperity.

FERDINAND G. WIECHMANN.

*AMERICAN MATHEMATICAL SOCIETY.*

THE fifth Summer Meeting of the Society was held at the Institute of Technology, Boston, Mass., on Friday and Saturday, August 19th and 20th. The attendance exceeded that at any previous meeting of the Society, reaching about seventy, including fifty-three members. The number of papers presented also shows a material increase. Nearly all the officers of the Society were present. The President, Professor Simon Newcomb, occupied the chair at the opening session, and was relieved later by the Vice-Presidents, Professors R. S. Woodward and E. H. Moore. The Council announced the election of four new members and the receipt of six applications for membership. A committee of five was appointed by the Council to consider the question of securing improved facilities for the publication of original mathematical papers in this country.

Two years ago a Colloquium was held in connection with the Summer Meeting at Buffalo. At the Toronto meeting last year it was not convenient to retain this feature. But this year it was decided to revive it, and in the week following the regular session twenty-eight members of the Society met at Cambridge to attend the courses of lectures offered by Professors W. F. Osgood and A. G. Webster. The title of Professor Osgood's course was: 'On Some Methods and Problems of the General Theory of Functions;' that of Professor Webster's was: 'The Partial Differential Equations connected with Wave Propagation.' The success attending the Colloquium will prob-

ably ensure the retention of this feature at the future summer meetings.

The most cordial relations prevailed between the Society and Section A of the American Association. The latter body set apart a special day (Thursday) for the reading of the chief mathematical papers, an arrangement which was greatly appreciated by those members of the Society who wished to attend both the Colloquium and the meeting of Section A.

The following is a list of the papers presented at the Fifth Summer Meeting:

- (1) DR. E. M. BLAKE: 'On the ruled surfaces generated by the plane movements whose centrodes are congruent conics tangent at homologous points.' (Illustrated by models.)
- (2) PROF. T. F. HOLGATE: 'A second locus connected with a system of coaxial circles.'
- (3) DR. J. I. HUTCHINSON: 'On the Hessian of the cubic curve.'
- (4) DR. VIRGIL SNYDER: 'Asymptotic lines on cubic scrolls.'
- (5) PROF. ALEXANDER CHESSIN: 'Relative motion considered as disturbed absolute motion.'
- (6) PROF. A. L. BAKER: 'Fundamental algebraic operations.'
- (7) PROF. ALEXANDER CHESSIN: 'On the development of the perturbative function in terms of the mean anomalies.'
- (8) PROF. E. O. LOVETT: 'Note on the differential invariants of a system of  $m + 1$  points by projective transformation.'
- (9) PROF. W. F. OSGOOD: 'Note on the extension of the Poincaré-Goursat proof of a theorem of Weierstrass's.'
- (10) PROF. W. F. OSGOOD: 'Supplementary note on a single-valued function with a natural boundary, whose inverse is also single-valued.'
- (11) PROF. MAXIME BÔCHER: 'The theorems of oscillation of Sturm and Klein.'
- (12) PROF. A. L. BAKER: 'Space concepts in mathematics.'
- (13) DR. T. P. HALL: 'An algebra of space.'
- (14) PROF. E. H. MOORE, 'The subgroups of the generalized modular group.'
- (15) PROF. L. L. CONANT: 'An application of the theory of substitutions.'
- (16) DR. J. H. BOYD: 'A method for finding an approximate integral for any differential equation of the second order.'
- (17) DR. H. F. STECKER: 'Non-euclidean cubics.'



(18) DR. G. A. MILLER: 'On the simple isomorphisms of a Hamiltonian group to itself.'

(19) DR. L. E. DICKSON: 'A new triply-infinite system of simple groups obtained by a two-fold generalization of Jordan's first hypoabelian group.'

(20) DR. L. E. DICKSON: 'Construction of a linear homogeneous group in  $m$  variables.'

(21) MR. JACOB WESTLUND: 'On a class of equations of transformation.'

(22) PROF. F. MORLEY: 'A generalization of Desargues' theorem.'

(23) DR. E. L. STABLER: 'A rule for finding the day of the week corresponding to a given date.'

(24) DR. ARTEMAS MARTIN: 'Evolution by logarithms.'

(25) DR. ARTEMAS MARTIN: 'A method of finding without tables the number corresponding to a given logarithm—II.'

F. N. COLE,  
*Secretary.*

*BOSTON MEETING OF THE NATIONAL GEOGRAPHIC SOCIETY.*

A SPECIAL meeting of the National Geographic Society was held, in connection with Section E of the American Association for the Advancement of Science, in the lecture hall of the Boston Society of Natural History, August 25th, 2 to 4:30 p. m., Vice-President W J McGee presiding in the absence of President Bell; in addition to the members of the Section, a number of the working members of the Society, including a quorum of the Board of Managers, were in attendance.

The first communication was by Marcus Baker, of the U. S. Geological Survey, on 'The Venezuela-British Guiana Boundary Dispute.' Mr. Baker was the geographer of the Boundary Commission appointed by President Cleveland near the end of 1896, consisting of Justice David J. Brewer, Dr. Andrew D. White, Professor Daniel C. Gilman, Justice Richard H. Alvey and F. R. Coudert, Esquire, with S. Mallet-Prevost as Secretary. This Commission, made up of eminent American citizens, undertook a critical examination of

the boundary dispute in that broad and liberal spirit characteristic of American statecraft and diplomacy. Their inquiries were so shaped as to cover the entire history of settlement and occupation of the territory involved; months were spent in searching the archives of both America and Europe for maps and records; and considerable progress was made in the arrangement of this material before the duties of the Commission were brought to an end through an international agreement. While peace-loving citizens and subjects alike rejoiced when the Commission found its occupation gone, those who knew of its work and plans suffered a certain disappointment; for the Commission was the ablest and most disinterested ever created to consider international complications, and the report, if carried out in accordance with the original plan, would undoubtedly have afforded a model for all nations. It was in line with the policy of rendering every line of inquiry exhaustive that the Commission employed a geographer, recommended by the President of the National Geographic Society and the heads of the scientific institutions engaged in geographic work for the federal government. The report of the Commission was far from complete, by reason of the cessation of the work when only well begun, but comprises three octavo volumes with a folio atlas, published within a few months. Mr. Baker summarized the geographic material contained in this report, and described the geographic conditions of the disputed territory. His remarks were illustrated by maps compiled from all available sources.

Mr. F. P. Gulliver, of Harvard University, discussed a 'Classification of Coastal Forms,' giving on the blackboard full illustrations of types. The classification proposed is genetic; and the great facility of classifying islands, bars, promontories, sea-cliffs, beaches and other coastal fea-

tures in this way, and thereby forming simple conceptions of otherwise complex phenomena, was happily brought out. The communication marks a noteworthy advance in the coordination of geographic knowledge.

Vice-President McGee gave an address on 'The Growth of the United States,' illustrated by tables and diagrams. It was the purpose of the address to direct the attention of geographers to the more important episodes in the history of the country and the beneficial effect of these episodes on individual and national prosperity. The territorial growth of the United States has been almost unparalleled in the areas acquired, and quite unparalleled in the rapidity and completeness with which the new territory and resources have been assimilated; no acquisition has been followed by disaster or difficulty, while every accession has stimulated enterprise and quickly resulted in increased facilities, augmented population and greatly enhanced individual and collective wealth. The values were shown quantitatively by means of diagrams, which render it clear that the incomparable growth of the United States in enterprise, population, commerce and wealth is directly traceable to that territorial expansion which has been one of the most conspicuous features in the history of the nation. It was pointed out that the Louisiana purchase made America a steamboat nation; that the acquisition of Texas and California made America a railway and telegraph nation, and incidentally that the events of 1898 must bring America to the front in the only line in which she is backward and feeble, *i. e.*, marine shipping. The address is printed in the September number of the *National Geographic Magazine*.

Mr. Mark S. W. Jefferson presented an illustrated paper on 'Atlantic Estuarine Tides.' His data were derived partly from the reports of the U. S. Coast and Geodetic

Survey, partly from other sources; they were combined in such manner as to explain the apparent abnormalities in the tides of the middle and northern Atlantic slopes, and to reduce the whole to definite system. The tides of the principal estuaries were tabulated; the bay type and the river type of tide were distinguished; and the relation between configuration and other factors and the ebb and flow of the local tide was illustrated by numerous examples. The paper is one of a series on which the author is engaged, some of which are assigned for early numbers of the *National Geographic Magazine*.

Mr. John Hyde, Statistician of the Department of Agriculture, presented a summary statement of 'Considerations Governing Recent Movements of Population.' Adverting to the marvellous development of transportation facilities within recent decades, the author directed attention to the growing instability of population; to the habit of seeking new lands and climates where conditions of life were more favorable, and to the flocking of people to districts giving promise of material or moral advantage. It is largely to these conditions that the enormous immigration to the United States must be ascribed. It is a significant fact that, when the emigration from fatherlands in Europe to the United States and to the colonies of the home governments is compared, it is found that the greater part of the home-seekers have drifted to America, rather than to the colonies of their own country. This fact indicates that material advantage is but one of the conditions governing movements of population, and that another impressively potent factor is the desire for that intellectual freedom guaranteed to the American immigrant by the Constitution and consistent policy of the United States.

In the absence of the authors, the following papers were read by title: 'Some New

Lines of Work in Government Forestry,' by Gifford Pinchot; 'The Forestry Conditions of Washington State,' by Henry Gannett; 'The Five Civilized Tribes and the Topographic Survey of Indian Territory,' by Charles H. Fitch; 'The Bitter Root Forest Reserve,' by Richard U. Goode.

On motion of Mr. Hyde, the following resolution was adopted:

"WHEREAS, through the increasing consumption of forest products, the destruction of forests and the vast extension of means of transportation, questions hitherto of restricted bearing are rapidly assuming grave international importance, and

"WHEREAS, the National Forest Association of Germany has undertaken to collect throughout the world forest information and statistics of commercial importance.

"Resolved, That the National Geographic Society express its deep sense of the value to mankind of the work thus begun, and pledge its countenance and support to the investigation, and

"Resolved, That a committee of three be appointed by the Chair to communicate these resolutions to the National Forest Association of Germany, and to take such other steps as may be necessary to carry them into effect."

In conformity with the resolution, the Chair appointed Mr. Gifford Pinchot, of Washington, Chairman, and Messrs. William H. Brewer, of New Haven, and Arnold Hague, of Washington, as a committee to take requisite action on behalf of the National Geographic Society.

W J M

#### CURRENT NOTES ON ANTHROPOLOGY.

##### THE CASTINGS FROM BENIN.

WHEN the English captured the city of Benin last year they found and sent to the British Museum some three hundred remarkable bronze castings. These present animal and human figures with various ornaments in relief, the line strong and the workmanship of singular beauty.

The origin of this work has greatly puzzled ethnologists. Carlsen (*Globus*, 1897, No. 20) and Mr. C. H. Read, of the British Museum, think they are the work of

some European bronze founders who settled in the sixteenth century. Mr. H. Ling Roth (*Reliquary and Illustrated Archaeologist*, July, 1898) attacks this position with some good arguments, but closes his paper with the negative decision that "the question of the origin of this Bini art remains unsolved."

##### CRANIOLOGICAL INFORMATION DESIRED.

DR. MIES, whose address is 'Schilder-gasse, 21, Cologne, Germany,' has issued a leaflet requesting particulars as to the greatest breadth of normal adult skulls. Those who can furnish him such information should apply for his leaflet, which is ruled and numbered so that the measurements can be entered in the briefest and most perspicuous manner.

##### ETHNOGRAPHY OF THE UPPER PARAGUAY.

FOR an American ethnologist it is as agreeable to discover a new linguistic stock as it is for the zoologist to discover a new genus of mammals. This good fortune happened to Mr. Guido Boggiani on the river Paragnay. He obtained a vocabulary from a tribe called Guanas (a Guarani term meaning 'fine people' and applied to various tribes), living near the river about lat. 23° south. It turned out entirely different from any other known tongue. He proposes for it the name 'Ennima stock.' After comparing its words with those of all the stocks anywhere near it, I find no affinities except a few, and these doubtful, with some of the Tsoneca dialects of Patagonia.

The position of the Ennima as well as the other tribes on the upper Paraguay are described and figured by Mr. Boggiani in an article in the *Boletin* of the Argentine Geographical Institute, Vol. XVIII., 1898.

##### MOTIVES OF SUICIDE.

IN *Globus*, July 16th, Dr. Richard Lasch refers to such motives for suicide as love,

sorrow, fear, melancholy, despair, illness, etc., and adds another—revenge. By numerous quotations he shows that in many primitive peoples, and those partly civilized, a person would kill himself to spite another. This he explains by the belief that the soul of the suicide would have the power to torment his enemy during the latter's life; not only this, but the death of the suicide would be attributed by his kinsfolk to the enemy and the penalty of blood-revenge would be demanded.

Doubtless this is true at times, but the theory is rather too finely spun. Suicide from an obscure motive of this nature is not rare in civilized lands where such beliefs and customs do not exist. Lovers kill themselves that their cold lady-loves may grieve (which they generally do not); children kill themselves that their parents may be sorrowful. Foolish, but human!

D. G. BRINTON.

UNIVERSITY OF PENNSYLVANIA.

#### NOTES ON INORGANIC CHEMISTRY.

FROM the twenty-eighth annual report of the Deputy Master and Comptroller of the Mint, 1897, *Nature* has taken a memorandum by Professor Roberts-Austen on the treatment of the surface of medals of silver and bronze. For centuries silver medals have been issued in England with the tables or flat surfaces smooth and mirror-like, while a more or less frosted surface has been given to the portions in relief. Owing to the ready discoloration of the polished surface, in France it has been customary often to use unpolished dies and to give the medals a dead surface by rubbing with pumice. More recently the sand blast has been used for this purpose. This surface may be further treated by immersion in a soluble sulfid, or better in a platinum solution, when a black surface is obtained which may be more or less removed by rubbing with brush

and pumice. Very beautiful shadow effects may be obtained, and many medals were thus treated at the (British) Mint in 1897 for the first time.

IN the case of bronze metals much of the beauty of the earlier medals was due to the fact that instead of being struck they were cast, and a thin layer of oxid was acquired in the process. Most modern 'bronze' medals are really copper 'bronzed' or artificially colored on the surface. The production of this color is by various methods, but generally by boiling with dilute solutions of certain salts, of which verdigris and sulfate of copper are the most important. The finest work in this line is that of Japanese artists, and its beauty seems to be chiefly due to the quality of the verdigris used. This verdigris, known as 'Rokusho,' is produced by the action of plum-juice vinegar on plates of copper containing certain metallic impurities. Very fair effects in bronzing are obtained with ordinary European verdigris, and this process is used in the British Mint. In France medals are struck of true bronze, with a high percentage of zinc, and the color is improved by gentle heating, producing superficial oxidation, but no true patination.

At the recent meeting of the American Association in Boston a paper was read by Charles L. Reese on quartz crystals from Diamond Post-office, near Guntersville, Marshall county, Ala., which contain inclusions of petroleum. Some of the cavities of these crystals measure as much as 2.3x1.8x1 mm. On warming, the petroleum globule bursts and wets the walls of the cavity. The contents of the cavities were identified as petroleum by the yellow-green fluorescence, the stain of the crushed crystals on filter paper, and the characteristic odor and smoky flame. Petroleum also occurs in the neighborhood where the crystals were found.

J. L. H.



## SCIENTIFIC NOTES AND NEWS.

ON the occasion of the meetings of the Congresses of Zoology and Physiology at Cambridge the University conferred its honorary degree of Doctor of Science on Professor H. P. Bowditch, of Harvard University; on Professor Anton Dohrn, Director of the Zoological Station at Naples; on Professor Alphonse Milne-Edwards, Director of the Museum of Natural History at Paris; on Professor Camillo Golgi, professor of general pathology in the University of Pavia; on Dr. Ernst Haeckel, professor of zoology in the University of Jena; on Dr. A. A. W. Hubrecht, professor of zoology in the University of Utrecht; on Dr. Hugo Kronecker, professor of physiology in the University of Berne; on Dr. Willy Kühne, professor of physiology in the University at Heidelberg, and on Professor E. J. Marey, professor of natural history at the Collège de France.

GENERAL SÉBERT has been elected Vice-President of the French Association for the Advancement of Science and, in accordance with the custom of the Association, will be President at the Paris meeting of 1900. M. Brouardel will preside at the meeting next year, which will be held at Boulogne.

DR. W. McM. WOODWORTH has been appointed assistant in charge of the Museum of Comparative Zoology, of Harvard University.

PROFESSOR ROBERT HELMERT, Director of the Geodetic Institute at Potsdam, has been elected a corresponding member of the Göttingen Academy of Sciences.

DR. H. KIEPERT, professor of geography at Berlin, has celebrated his eightieth birthday.

DR. K. GOEBEL, professor of botany at Munich, has gone to Australia for purposes of botanical research.

PROFESSOR ADOLF BASTIAN, of Berlin, has returned from his expedition to southeastern Asia, where, during the last two and a-half years, he has been carrying on important ethnological investigations.

DR. W. F. HUME will, during the coming year, make surveys in the peninsula of Sinai, under the auspices of the Egyptian Geological Survey.

DR. L. A. BAUER, of the University of Cincinnati, was made an honorary member of the Société Scientifique 'Antonio Alzate,' Mexico, at its meeting of July 5, 1898.

M. PILLIET has been appointed Director of the Musée Dupuytren, which contains the anatomical collections of the medical faculty at Paris.

A MONUMENT to Gui Patin, in the middle of the seventeenth century professor of surgery and Dean of the Paris faculty of medicine, was unveiled at d' Hodenc-en-Bray, his native place, on August 22d.

WE regret to record the death of Dr. Paul Glan, associate professor of physics in the University at Berlin, at the age of fifty-two years; of Dr. E. J. Bonsdorf, formerly professor of anatomy and physiology in the University of Helsingfors, at the age of eighty-eight years; and of Professor L. von Dittel, formerly professor of surgery at the University of Vienna, at the age of eighty-three years.

THE Nineteenth Congress of French Geographical Societies will meet at Marseilles from the 18th to the 25th of September.

WE learn from *Nature* that a Congress of the Astronomische Gesellschaft will be opened at the Academy of Sciences at Budapest on September 24th. Meetings will also be held on Monday and Tuesday, September 26th and 27th. The Hungarian members of the Society have prepared a cordial reception for the astronomers who attend the Congress, among the hospitable features being a luncheon to be given by the Minister of Public Instruction (Dr. Julius von Wlassitz), a dinner by the town of Budapest, visits to places of interest in the town and neighborhood and excursions to the O'Gyalla Observatory and the Danube Cataracts—the Iron Doors. The Congress will certainly give a prominent place to the discussion of questions concerning the international zone catalogue of the Astronomische Gesellschaft; and the resolutions of the Paris Conference, which have given rise to a large amount of criticism, will also be dealt with. Professor F. Porro will present a preliminary report on the revision of the Piazzi Catalogue of Stars, undertaken by Dr. H. S. Davis and himself.

THE Venice Academy of Science, Letters and Arts offers a prize of \$600 from the Querini-Stampalia Foundation, for an investigation of the water power of the Venetian province, with a view to its increased application. Essays, which may be written in English, must be presented before the end of next year.

THE Dutch Academy of Sciences of Harlem proposes eighteen subjects for essays, offering for each a gold medal or a prize of 500 florins. The details may be obtained from the Secretary of the Academy, Professor J. Bosscha, Harlem.

MME. BRAGAYRACT has bequeathed 50,000 fr. to the Paris Academy of Medicine.

PLANS are being made at Turin for the establishment of a fresh-water aquarium intended to advance the interests of pisciculture.

THE Indiau government has decided to send exhibits from the Forest and Geological Department to the Paris Exhibition at a cost of about £3,000.

THERE are now about 350 public libraries in Great Britain. These libraries contain over 5,000,000 volumes, and issue about 27,000,000 books each year. The annual attendance of readers is about 60,000,000. In comparison with these figures the following, recently published, will be interesting: There are 844 public libraries in Australia, with 1,400,000 volumes; 298, with 330,000 volumes, in New Zealand; 100, with 300,000 volumes, in South Africa. In Canada the public libraries contain over 1,500,000 volumes. In 1896 the United States, according to government statistics, possessed 4,026 public and school libraries, containing 33,051,872 volumes.

*Nature* states that a committee, having upon it many distinguished men of science in Australia, has been formed to secure the establishment of some permanent memorial to commemorate the services rendered by the late Baron von Mueller. This movement is entirely distinct from that which the executors of the late Baron have initiated with the object of obtaining funds for the erection of a tombstone. The object of the Committee of the National Memorial Fund is to secure sufficient funds to allow of the establishment of some permanent memorial which shall worthily perpetuate Baron

von Mueller's name; and whilst it is not possible as yet to state definitely the form which the memorial will take, it is hoped that sufficient funds will be forthcoming to provide for (1) the erection of some form of statue, and (2) the endowment of a medal, prize or scholarship, to be associated with Baron von Mueller's name, and to be awarded from time to time in recognition of distinguished work in the special branches in which he was most deeply interested, and which shall be open to workers throughout the Australasian colonies. Subscriptions to the fund may be sent to the Hon. Treasurer, addressed to the College of Pharmacy, Swanston Street, Melbourne, or to the Hon. Secretaries (Mr. W. Wiesbaden and Professor Baldwin Spencer), addressed to the University of Melbourne, and will be duly acknowledged.

CHANCELLOR HOHENLOHE has sent a communication to the German Colonial Society in reply to a request for information as to the official attitude towards Professor Koch's theories on the subject of malaria. He says, as reported in the *New York Evening Post*, that as soon as the Colonial Department of the Foreign Office "had knowledge of the highly important results of the investigations of Dr. Koch, and of the proposals based on them by him, it distributed the information in several directions. Dr. Koch appealed, for instance, to the Prussian Ministry of Medical Affairs, to which he is officially subordinate, that means should be obtained for two great scientific expeditions under his leadership, with a view to completing his investigation of malaria. According to his plan, the first of these expeditions should investigate malaria in Italy and Greece, and the second in the most intense fever foci of East Africa, India and New Guinea. The first is to last three months and the second two years. The Prussian Ministry and the Foreign Office are most keenly interested in this enterprise, and I do not doubt its practicability. \* \* \* In order to render the present results of Dr. Koch's researches concerning the diagnosis treatment and prophylaxis of malaria useful to medical men in the colonial service, suitable training will be given them in the Institute for Infectious Diseases, of which he is the head. This train-

ing is given under Dr. Koch's superintendence, and several medical men are already receiving it. The colonial doctors will also be provided with the scientific apparatus proposed by Dr. Koch. Each of them will thus be enabled to turn the special scientific training received by him for his work in our protectorates to account, furnished with all the means of modern science in exact accordance with Dr. Koch's prescriptions and doctrines."

THE German Arctic expedition of Theodore Lerner, which started in May last to search for Andrée and to carry on scientific investigation, has returned to Hammerfest, Norway, in order to enable the *Helgoland*, to refit prior to starting on another voyage. Herr Lerner could find no trace of Andrée, but secured scientific results of interest especially to geographers. A special representative of the *Berliner Lokalanzeiger*, who accompanied the expedition, has forwarded to that journal a long and detailed account of the voyage, of which an abstract is given in the *London Times*. Horn Sound was reached after some difficulty; owing to the unusual quantity of floe ice, which, breaking off from the glaciers, kept sweeping down with terrific force, anchorage was rendered very difficult and dangerous. Towards the end of July King Charles Islands were reached, where a halt of a few days was made. From scientific observations made they were able to define the exact position of the islands, and they discovered that the English and Norwegian maps were slightly inaccurate. The group consists of three big islands—namely, Swedish Foreland, Jena Island, and a third lying between these two, which they christened August Scherl Island in honor of the promoter of the expedition. There they came upon the breeding grounds of the ivory gull (*larus eburneus*), very few specimens of whose eggs have hitherto been discovered. Two small islands in the southern bay of Jena Island received the names of Tirpitz and Helgoland respectively. Captain Rüdiger took special observations of the exact position of King Charles Islands. An attempt to push on to Franz Josef Land failed owing to bad weather. The *Helgoland* then was able to coast round the island on the northeast and from the south, in spite of the difficulties caused by fog and ice,

thereby proving that it is possible to go northwards notwithstanding the contrary Polar currents. The exact position of the island of Störö is given as being 10' farther north than it is at present indicated on maps. The most northerly point reached was latitude  $81^{\circ} 32'$ , where the boundary of pack ice was determined. Much hitherto unknown ground was fished with dragnets, especially round the east point of King Charles Islands, and at the extreme end of Spitzbergen in waters of over 1,000 meters deep. A good deal of interesting material was found. No signs of the Andrée expedition were discovered. Many seals and a large number of reindeer were killed, as well as forty-four exceedingly fine polar bears. Four live cubs are being brought back to Germany. Professor Richard Friese, the celebrated animal painter, was able to make some excellent sketches, and many photographs were taken of the hitherto unexplored lands. Among other interesting subjects for future investigation by bacteriologists it is stated that the existence of plankton was established at over 100 hauls of the dragnets. The expedition will start on another voyage of exploration as soon as the ship has been refitted and the necessary stock of victuals been taken on board.

THE program of the forthcoming meeting in Sweden of the Iron and Steel Institute, says the *London Times*, opens up a prospect of an unusually important gathering, not so much from the point of view of the papers to be read—although they are of great interest—as from that of the information which the members of the trade are likely to obtain as to the suitability of the iron-ore resources of that country to their urgent requirements in the near future. The papers include one on the most prominent and characteristic features of Swedish iron-ore mining, by Professor Nordenström, and another on the iron-ore deposits of Swedish Lapland, by Mr. Lundbohm, of the Swedish Geological Survey. These papers, and the discussions on them, will be supplemented by a special excursion to the mines within the Arctic Circle. The ore in that region is of the highest quality—much higher in iron than any other similar deposits in Europe—and it is believed that, when a new railway has been completed to connect



the mines with the Atlantic Ocean, the ore can be delivered in England as cheaply as any supplies now available on a large scale. Another important subject to be discussed is the action of explosives on the tubes of steel guns, as to which Professor Roberts-Austen, C.B., of the Mint, will read a paper based on important recent experiments, while the proper composition of steel rails, which will also be debated, will be of unusual importance, in view of the inquiry by the departmental committee of the Board of Trade. Several other papers of a more highly technical character will be considered, while the hospitality to be offered to the visitors will include a reception by King Oscar at his summer palace, and a banquet by the Association of Swedish Ironmasters. Dr. H. S. Lunn has specially fitted up the steam yacht *Argonaut* to convey the members to Sweden, and she will serve as a floating hotel during their stay.

In introducing an article on 'The Species, the Sex and the Individual,' by Mr. J. T. Cunningham, the editor of *Natural Science* makes the following remarks: "With reference to this paper Mr. Cunningham has given us the following information, which we have verified. The paper was written at the beginning of 1897, and after some time was submitted to the Zoological Society, but not accepted, even for reading, on the ground that the Society did not usually publish papers of a theoretical and controversial character. The manuscript was then sent to the Linnæan Society, where it was read on May 6th of the present year, and a brief description of it was published in the report of the meeting in the *Athenæum* and in *Nature*. But this Society also refused to publish the complete paper, the alleged reason being the pressure of other papers and illustrations. It is due to Mr. Cunningham that these facts should be known, for on June 7, 1898, there was read before the Zoological Society a paper by Mr. L. W. Wigglesworth, containing conclusions as to sexual dimorphism very similar to those of the present paper. In particular, as published abstracts show, the author maintained that secondary sexual characters in birds were due to the stimulation of parts through use, or external violence, or irritation. So much for

Mr. Cunningham's title to priority. As for the refusal to publish his paper we understand that the Zoological Society has equally refused that favor to Mr. Wigglesworth, although he was more fortunate in having his views placed before a meeting and published in abstract. There is a general feeling among those who hold views opposed to the current strictly Darwinian notions that they cannot get fair play from our learned societies. It is a pity that they should be able to adduce so many facts in support of this opinion, however erroneous the opinion itself may be."

#### UNIVERSITY AND EDUCATIONAL NEWS.

THE corporation of Brown University has accepted the resignation of Dr. E. Benjamin Andrews as President, passing resolutions expressing appreciation of his services, and has elected a committee of six to choose his successor. Professor Benjamin F. Clark, A.M., has been made Acting President.

DR. W. WALDEYER, professor of anatomy, has been appointed Rector of the University of Berlin, for the coming year; Dr. von Lommel, professor of physics, Rector at Munich, and Professor Luigi Luciani, the physiologist, Rector of the University of Rome.

THE vacancies in the fellowships of the Teachers College caused by the resignation of Dr. Cleveland Abbe, Jr., and Mr. E. B. Bryau, have been filled by the appointment of David R. Major, Ph. D. (Cornell), and B. B. Breeze, A. M. (Harvard). Mr. Breeze has been for the past two years assistant in the Harvard Psychological Laboratory.

MISS KATHERINE VON TUSSCHENBROCK has been appointed to a chair of gynecology in the University of Utrecht. The University of Genoa has given its M.D. to Miss E. Bonomi, which is said to be the first time the degree has been given to a woman by an Italian University.

DR. GEORG KLEBS, professor of botany at Basle, has been called to Halle and is succeeded at Basle by Dr. Wilhelm Schimper, associate professor at Bonn.

THE position of instructor in histology at the Harvard Medical School is vacant. The appointment is an annual one with a salary of



four hundred dollars. The holder is expected to give twenty hours a week to the work of the laboratory, and to devote the remainder of the time to original investigation in histology or embryology under the supervision of the senior officers of the department. Applications should be addressed at once to Professor Charles S. Minot, Harvard Medical School, Boston.

#### DISCUSSION AND CORRESPONDENCE.

##### PRE-COLUMBIAN MUSIC AGAIN.

TO THE EDITOR OF SCIENCE: The question of Pre-Columbian stringed instruments of music in America comes up again, this time from Carl Sapper, the distinguished geologist in Coban, Guatemala. He had learned of my former letter on the distribution of the musical bow and conceded with regard to the *Loltun Hool*, of the Mayas, that it was surely introduced from Africa, since the Kekchi call it *marimbadie*, or *caramba*. The same instrument is in use among the Xicaques, in Honduras, but they attach a *guacal* as a resonator. Dr. Sapper does not agree with me that the stringed musical instrument was entirely absent from the western hemisphere, for, says he, the Lacandones have a two-armed guitar, which he thinks not to have been borrowed. The Kekchi also, says Sapper, uses strings on the scraping instrument, called 'su.' This is entirely new to me. As to the double-necked guitar, Mr. E. H. Hawley says that they were common in Europe and may be seen in collections. These have the necks projecting from the same end and parallel or slightly diverging. The Fans have a variety in which the two necks start from opposite sides of the body. One example is made from the stem of a palm leaf 55 inches long. Four strings are cut from the outer skin, their ends being left attached. A little way from the middle a stick is set up perpendicular to the palm stem. On one margin of this are cut four notches or steps, about half an inch apart, to receive the strings. Braided bands of palm fibre encircle stem and strings, and by moving these the latter are tuned. Opposite the upright stick or bridge is tied an open gourd for resonator. I should be glad to receive descriptions of these Central American

instruments or drawings. Most of all, would I like to examine specimens. If by the scraped instruments Dr. Sapper means some modification of the notched fiddle, then he has found a prize, but not necessarily a pre-Columbian one.

O. T. MASON.

#### A CURIOUS OPTICAL ILLUSION CONNECTED WITH AN ELECTRIC FAN.

A CURIOUS illusion connected with an ordinary two-winged pendant fan, such as are commonly employed in restaurants, barber shops, etc., attracted my attention some years ago, and lately, upon my return to the same place, was just as evident as formerly. Very much at a loss for an explanation, the phenomenon was described to one of our leading psychologists and educators, but no satisfactory explanation was obtained. Hence, it is supposed that possibly the phenomenon has not been noticed by others, and is described here for the benefit of those concerned and with the hope of drawing out similar observations by others.

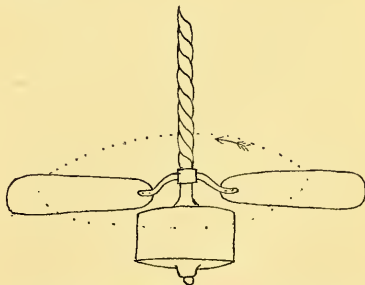

The illusion consists in the fan appearing to rotate in the opposite direction from the real one. Sitting some thirty feet away and looking at the fan, which is moving at a moderate speed, it is plainly seen to be moving in the direction opposite to that of the hands of a watch. The plane of rotation appears to be horizontal. But as one continues looking the vanes suddenly seem to move in the opposite direction and the plane of rotation to change so as to incline towards the observer. The change is under the control of the will and may

be produced as readily as the illusions connected with a square within a square. A certain distance for a point of observation and also a certain speed of rotation appears to be necessary, for fans nearer the observer rotating more slowly do not produce the phenomenon which now seems to be due to the same principle of accommodation that makes a figure of a square within a square appear at one time as a hollow space and at another as a solid.

Two other illusions connected with the fan, but which may be well known to every one who has watched moving machinery, may be noted. In one the vanes, instead of rotating, seem to flap together; in the other the two iron arms appear to be continually withdrawing into and pushing out from the hanging rod.

F. C. KENYON.

#### SCIENTIFIC LITERATURE.

*Plant Life, Considered with Reference to Form and Function.* By CHARLES REID BARNES, Professor of Plant Physiology in the University of Chicago. New York, Henry Holt & Co. 1898. 12mo. Pp. x + 428.

In his preface the author says: "The absence of an elementary account of the form and functions of the plants of all groups has made itself felt," and "I am not aware that any book at present attempts to meet this need." These sentences, coupled with the author's reference to secondary schools, and to pupils of thirteen to eighteen years of age, indicate the purpose and place of the book.

In carrying out his plan he has divided the subject into four parts, viz.: (1) the vegetative body; (2) physiology; (3) reproduction, and (4) ecology. In the first part appear such chapter headings as 'the unit of structure,' 'single-celled plants and colonies,' 'linear and superficial aggregates,' 'the thallus of the higher algæ,' 'the fungus, body of hyphal elements,' 'liverworts and mosses,' 'fernworts and seed-plants.' A few years ago such an approach to what was then called 'morphology' would have horrified the old-time teachers of elementary botany, who were anxious to give the study as much 'practical' value as possible, and were wont to repeat pedagogical platitudes as to the necessity of 'proceeding from the known

to the unknown.' Ignoring such objections, the author leads the pupil, chapter by chapter, from the relatively simple plant-body of the fission algæ to the highly complex structures, roots, stems and leaves, of the seed plants. The significance of the latter is thus made much clearer than by the old method of studying the anatomy of flowering plants first, and then following with something of the lower forms from which they sprang.

The treatment of the physiology of plants is satisfactory, as a matter of course, since the author has given especial attention to this department of botany. In the introduction some clear and useful definitions are given; then follows a suggestive chapter on the maintenance of bodily form, one on nutrition (particularly well done), one on growth and another on the movements of plants.

The chapters relating to reproduction must be very helpful in giving the beginner right notions as to how plants provide for a succession of individuals. Old-fashioned people will open their eyes when they find the 'flower' discussed in the chapter treating of vegetative (*i. e.*, asexual) reproduction, along with 'fission,' 'budding,' 'spores' and 'brood buds.' The 'flower' is brought in under the general topic 'spores,' after the discussion has led up to the differentiation of spores into megaspores and microspores. Of course, this is all right, as every botanist knows, but there will be some scrambling and tumbling on the part of many a high-school teacher as he attempts to lead his pupils through this, to him very new, territory, and we imagine that he will fare little better when he comes to the angiosperms in the chapter on sexual reproduction. In order fully to master this matter the teacher will, in most cases, be obliged to spend a term or two in some good botanical laboratory, where he can be helped over the difficult places.

The chapters on ecology are new to American books on botany, and while they are quite elementary they will be useful in the way of directing students and teachers into a comparatively new field of work.

The appendices are in some respects of more value than the body of the book, giving as they do: (1) directions for laboratory study; (2) direc-

tions for collecting and preserving material; (3) lists of apparatus and reagents; (4) lists of reference books, and (5) outline of classification.

Some new uses of old terms are introduced here and there. Thus we have 'ovary' used for oogone, carpogone and archegone, and 'ovulary' for the structure hitherto called the ovary in the flowering plants. 'Sperm' and 'spermary' replace antherozoid and antherid. 'Egg' is consistently used throughout for the female gamete. We do not quite like the use of 'megaspore' as synonymous with 'embryo sac' in angiosperms, and feel sure that it will lead to the confusion of the beginner. It is doubtless impossible to make a clear statement of all the homologies of the gametophyte of angiosperms in an elementary work, but it is certainly not necessary to simplify the statement by running together two structures so distinct as the uninucleate megaspore and the multinucleate embryo sac.

We trust that the author's wish may be realized, namely, "it is greatly to be desired that the too common thought of plants as *things to be classified* may be replaced by the conception of them as *beings at work, to be studied alive*," and we believe that his book will help to bring it to pass.

CHARLES E. BESSEY.

*Grundprobleme der Naturwissenschaft. Briefe eines unmodernen Naturforschers.* By DR. ADOLF WAGNER. Berlin, Gebrueder Borntraeger. 1897. Pp. vi + 255.

The sub-title of this sharp little polemic might well have been *Schopenhauer versus Büchner*. There is much else in the book, but that about it which is most vital is the application of the philosophy of *Welt als Wille und Vorstellung* to such views of nature as characterize *Kraft und Stoff*. But the actual sub-title does very well. 'Unmodern' the author certainly is. *Kraft und Stoff*, his arch-enemy, long ago had its day; and even the aftermath of discussion over Ostwald's Lübeck address, the most modern scientific matter of which he seems conscious, has been garnered in. This is the most obvious fact about the book; it is belated. The ultra materialistic views of nature and the hard and fast notions of matter, atom, molecule,

ether, etc., which the author ascribes to naturalists, are no longer held by them, or are held with a genial flexibility which make the Doctor's savage onslaught seem whimsical.

Then, the book is arrogant in tone. Rarely in these days does the venerable speculative philosophy so lord it over youthful science. Although the book takes the form of letters (in reality a single letter) addressed by a humanist to an old university friend in the other camp, yet the 'lieber Freund,' in spite of the constant 'Du' and 'Dir,' everywhere gets hard blows and short shrift. His views are 'nonsense,' 'absurd,' 'impossible to one who has had a single semester of philosophy,' etc.

And yet it would not be easy to find a better *résumé* of the idealist position with regard to the fundamental problems of nature and science. The book is very readable. It is full of matter. The style is picturesque, lively and popular; the argument clear and mercifully brief. It is a strong book of its kind.

The first half of the book is a coherent argument for a certain view of the world; the second part seems to be occupied (I have not read it completely) with an elaborate *a priori* discussion of the nature of human, animal and plant life. With regard to this part it is only necessary to remark how the philosopher, after belaboring the eternal *is* (the assumption of existence and reality) of science, allows his own equally gratuitous *must be* to run riot. How should it be so difficult to see that we cannot any more get outside and beyond ourselves in philosophy than in science. We project ourselves into our science. Granted. But so, too, we project ourselves into our philosophy, which is, out and out, as truly as science, a creature of taste, mood, temperament, race, age and environment.

What, then, are the 'Grundprobleme?' They are questions concerning the nature of things; concerning criteria of reality; concerning the relation of experience to knowledge. You scientists build upon experience. First find how far experience is valid. You talk of realities. What do you mean by reality? What are your tests of reality?

The author, though everywhere affirming the idealist position, very sensibly refrains from any



close classification of his philosophy. In general he might be spoken of as a spiritualistic monist, since he finds nothing in the world but the human will and the human will anthropomorphically projected into space, which projection he follows Schopenhauer in calling force (*Kraft*), and its localized manifestations energy. But this lightly held monism easily lapses into pluralism, and when he gets all his contestants on the arena together a pretty contest they put up. For example, first appears *reality as it is in itself*—a ghostly presence. To him enters the burly and self-confident *common notion of reality*, easily holding all eyes upon himself. Then comes in that keen-witted fellow, *interpretation of reality*, striving to put *notion of reality* in a hole and get on good terms with *reality itself*. And this is only a beginning. Even space and time appear to be distinct entities. For, speaking of the production of like effects by like causes, he says very truly that there are no two like causes. At least they must differ in place and time; which is very interesting if one thinks of it.

Then is the author wise in insisting, to the extent we find in the earlier chapters, upon the opposition of experimental science to speculative philosophy? He first gives standing to speculative philosophy by showing how all thinking, even scientific, is speculative, and then adroitly attributes to speculation its old meaning of inquiry into causes, essences and realities: Science is now the servant of speculation, or, to use his favorite figure, the hod-carrier bringing bricks and mortar to the philosopher-architect. But how if the hod-carrier chooses to be his own architect, finding that the man of speculation does not feel the properties of the material which he has not encountered at first hand, and that so his construction is not sound. And when reminded that the bricks and mortar of experience are man-made, can he not retort; but so is the temple? And may not this suggestion of inferiority sting him into asking whether any one of this endless succession of temples, falling into ruin almost as soon as built, is really a more noble object than the almost eternal elements of which each one in turn is made?

And is not the Doctor wrong in insisting that

men of science decry speculative philosophy? They only object to that which is not sober and fruitful. Speculation, indeed! They all love it as the apple of the eye! Who does not know that they live on bread and water and wear the hair shirt of inexorable verification to moderate this tendency. Dr. Wagner is right in thinking that all people have a deep interest in the nature of things, in cause, and necessity, and reality. Who among us is so much a positivist as to say, not only that we have not yet penetrated the soul of things, but that we never can; that it would be of no use if we could; that we ought not even to desire to. The experimental philosopher (if Dr. Wagner will permit this hated expression this once) does not travel the noble road of speculative philosophy simply because he has found that *for him* it is hedged up or leads no-whither. What does Dr. Wagner himself bring back from his search? Has he found an answer to his questions? Who has accepted this answer? While experimental science has been building up a body of knowledge which it is a liberal education to know, what sure and well accredited doctrine has speculation to offer? Where does it impinge upon science? How help, or illuminate, or direct? This is no objection to philosophy, but to its arrogance.

The chapters upon causality, or rather the law of causality, are suggestive, though not new. If there is some juggling with words here, where is there not in any full discussion of the subject? Every event is both cause and effect; the emphasis upon every. So the universe is all of a piece; all events in one series. This implies necessity and excludes accident. But cause in itself is one thing, cause for us another. Two events may belong to two, or many, quite different (for us) causal series. The motion of necessity does not exclude the motion of accident. Still there is no absolute accident. Causality has reference to becoming—development—and not to existence; *e.g.*, to heating, and not to heat; to vital changes, and not to life. He properly objects to divorcing form from content. If one rubs a glass rod with fur one does not bring about two results—create electricity and electrify the rod—but only one, the latter.



He follows Liebmann, *Analysis of Reality*, in asserting that force is not true cause. For example, force cannot produce motion. But he has in mind Schopenhauer's idea of force, a sort of synthesis of the powers of nature—may one say, the total potential energy of the universe—the thing-in-itself of the metaphysician. True force—always something akin to the human will—is that which releases this fundamental power, producing the various manifestations of energy. The true cause of the falling of a stone, for example, is not gravity, but the removal of an obstacle; and so in all motion. This view, sufficiently common in one form or another, may have little significance for physics, which concerns itself with the how and how much rather than the what and why, but is intrinsically important and deserves greater elaboration than it has hitherto received.

This view leaves no place for matter as something upon which force can act or in which it may 'reside.' The universe is to be explained dynamically. So all talk of atoms and molecules, except as for a time they may pictorially assist the learner, is aside from the purpose. They may be handy to have about, as they make no trouble and deny nothing, but they also explain nothing. Ostwald's concept is the true one, simply putting will for force and acts of will for energy.

For it is the world of will—of longing, of striving, of action—of which we are conscious. Here is the real world. But the will encounters opposition from without on the part of something which we feel to be akin to the human will—the powers of the external world. The nature of the world is will.

E. A. STRONG.

YPSILANTI, MICH.

*International Catalogue of Scientific Literature.*

Report of the Committee of the Royal Society of London, with Schedules of Classification. March, 1898. Schedule Q, Anthropology.

It will be remembered that at the International Conference for a Catalogue of Scientific Literature, held at London, July, 1896, the classification of the sciences to be catalogued was referred to the Committee of the Royal

Society for organization. The report of this Committee is now published, and it is to its classification of the Science of Anthropology (known as 'Schedule Q') that the present review is confined.

The Committee states that these schedules 'are not put forward as final or authoritative' (p. 9); therefore, an examination of them should be carefully carried out by special workers in science, to see how far a catalogue based upon them will reach the highest degree of usefulness.

Obviously, the schedule should include all the prominent branches of a science, and should reduce repetition of titles to a minimum.

With regard to Anthropology the Committee excludes from it the branches of experimental and comparative psychology, grouping these under the general schedule of 'Psychology' (Schedule P). While the anthropologist may regret this, it is in accordance with the precedents of the American Association and other similar bodies.

The general science of anthropology is divided into eleven primary branches, as follows: (1) Museums and Collections; (2) Archaeology (prehistoric); (3) Anthropometry; (4) Races; (5) Industrial Occupations and Appliances; (6) Arts of Pleasure; (7) Communication of Ideas; (8) Science ('chiefly of primitive races'); (9) Superstition, Religion, Customs; (10) Administration; (11) Sociology ('chiefly of primitive races'). The total number of sub-headings is seventy.

What will first impress the anthropological student in this classification of the subjects of his science are its omissions. Nothing is said of that most prominent branch sometimes called 'developmental somatology,' which investigates the influences of heredity and environment and the physical transformations of man (evolution, monogenism, polygenism, etc.)

The whole science of ethnography, as such, is overlooked, as under the unfortunate heading 'races' the only sub-titles are 'General Works,' 'Classification by Name and Language,' 'Racial Peculiarities.' Another ill-chosen term is 'arts of pleasure' as a synonym for the fine, or æsthetic arts. Many of the most noteworthy developments of these are in no sense ministers to

pleasure, such as the vast domain of religious and symbolic art; and consequently under none of the sub-headings are these mentioned. Why 'administration' and 'sociology' should be separated is not obvious, and that it is erroneous is apparent from the substantial duplication of the sub-headings, as 'marriage' under the former, 'relations of the sexes' under the latter; 'crimes' under one, 'ethics' under the other; 'governing powers' under the one, 'family and clan' under the other, and so on.

A curious omission in these days is that of folk-lore from the leading titles. It is a clear-cut, independent branch of anthropology, with a field of its own and a vast literature; yet it appears only as a third-rate subordinate subject; though the Committee perhaps thought to make amends for this by inserting it twice, once under 'arts of pleasure' and again under 'superstitions!' This would involve duplicating at least a thousand titles a year. The drama is placed under 'arts of pleasure,' history under 'science,' while writing and records are included under 'communication of ideas.' This seems a forcible divulsion.

The advanced anthropology of the present day does not intend to confine itself to 'primitive races' nor prehistoric remains, but aims to study the progressive and regressive developments of the species Man as a whole, and as divided by natural or artificial lines into groups, ethnic or demotic. All art, science and history, when treated in this spirit and for this purpose, become the material of the anthropologist, and the subjects of his investigation.

This broad comprehension of the spirit of the science seems obscurely set forth, or rather, is not at all recognized in the items of the schedule, and it is earnestly to be hoped that before it is proceeded with, it will be recast in a frame more adequately adapted to represent the true scope of anthropology.

D. G. BRINTON.

#### SCIENTIFIC JOURNALS.

THE greater part of the *Botanical Gazette* for August is taken up by an extensive and elaborately illustrated article carried out under the direction of Professor Geo. F. Atkinson, on the

'Development of some Anthracoses,' by Miss Bertha Stoneman. The paper aims to ascertain, by the growth-characters developed in artificial cultures, the relationships of certain fungus diseases grouped under the common name of anthracoses and the connection of these imperfect fungi with perfect stages. The other article of the number, by Mr. William L. Bray, discusses the relation of the flora of the lower Sonoran zone in North America to the flora of the arid zones of Chili and Argentine.

THE *American Naturalist* for August contains the following articles: 'Dentition of Devonian Ptyctodontidæ,' C. R. Eastman; 'The Wings of Insects' (III), J. H. Comstock and J. G. Needham; 'Alternation of Sex in a Brood of Young Sparrow Hawks,' R. W. Shufeldt; 'Noxious or Beneficial? False Premises in Economic Zoology,' Samuel N. Rhoads; and 'A Pocket Mouse in Confinement,' J. A. Allen.

THE frontispiece of *Appleton's Popular Science Monthly* for September is a portrait of Charles Goodyear and a sketch of the life of the inventor of vulcanized rubber is given by Mr. Clarke Dooley. The opening article is an illustrated account of geological waterways across Central America, by Dr. J. W. Spencer. There are popular entomological papers by Clarence M. Weed and Margaret T. D. Badenock, and several articles on educational and sociological topics.

#### NEW BOOKS.

*Introduction to the Theory of Analytic Functions.*

J. HARKNESS and F. MORLEY. London and New York, The Macmillan Company. 1898. Pp. xv + 336. \$3.00.

*Inorganic Chemistry According to the Periodic*

*Law.* F. P. VENABLE and JAMES LEWIS HOWE. Easton, Pa., The Chemical Publishing Company. 1898. Pp. v + 266. \$1.50.

*Organic Evolution Considered.* ALFRED FAIR-

HURST. St. Louis, Christian Publishing Co. 1897. Pp. 386.

*The Psychological Correlation of Religious Emotion*

*and Sexual Desire.* JAMES WEIR, JR. Louisville, Ky. 1898. Pp. 338.

*The Elements of Physics.* ALFRED PAYSON

GAGE. Boston, Ginn & Co. 1898. Pp. viii + 381.

# SCIENCE

EDITORIAL COMMITTEE: S. NEWCOMB, Mathematics; R. S. WOODWARD, Mechanics; E. C. PICKERING, Astronomy; T. C. MENDENHALL, Physics; R. H. THURSTON, Engineering; IRA REMSEN, Chemistry; J. LE CONTE, Geology; W. M. DAVIS, Physiography; O. C. MARSH, Paleontology; W. K. BROOKS, C. HART MERRIAM, Zoology; S. H. SCUDDER, Entomology; C. E. BESSEY, N. L. BRITTON, Botany; HENRY F. OSBORN, General Biology; C. S. MINOT, Embryology, Histology; H. P. BOWDITCH, Physiology; J. S. BILLINGS, Hygiene; J. MCKEEN CATELL, Psychology; DANIEL G. BRINTON, J. W. POWELL, Anthropology.

FRIDAY, SEPTEMBER 23, 1898.

THE ORIGIN OF GYMNOSPERMS AND THE SEED HABIT.\*

## CONTENTS:

<i>The Origin of Gymnosperms and the Seed Habit:</i> PROFESSOR JOHN M. COULTER.....	377
<i>The Development of Photography in Astronomy (II.):</i> PROFESSOR E. E. BARNAED.....	386
<i>Zoological Section (F) of the American Association for the Advancement of Science:</i> DR. ROBERT T. JACKSON .....	395
<i>Notes on Physics:—</i>	
<i>Section B at the Boston Meeting; The Flow of Water in Pipes; The Synchronograph; Science Abstracts; Cathode Rays; The Electrochemical Equivalent of Silver vs. the Mechanical Equivalent of Heat:</i> W. S. F.....	403
<i>Current Notes on Meteorology:—</i>	
<i>Papagueria; Tree Planting on the Plains:</i> R. DEC. WARD.....	405
<i>Bacteriological Notes:</i> DR. SIMON FLEXNER.....	406
<i>Current Notes on Anthropology:—</i>	
<i>An Unusual Aurora; Articles on Wampum; Native Face-painting:</i> PROFESSOR D. G. BRINTON.....	407
<i>Scientific Notes and News .....</i>	407
<i>University and Educational News .....</i>	410
<i>Discussion and Correspondence:—</i>	
<i>An Unusual Aurora:</i> PROFESSOR SIMON NEWCOMB.....	410
<i>Scientific Literature:—</i>	
<i>Flower's Essays on Museums:</i> F. A. L.....	411
<i>New Books.....</i>	412

## INTRODUCTORY.

THE most difficult as well as the most fascinating problem in connection with any group is its phylogeny. The data upon which we base opinions concerning phylogeny are never sufficient, but such opinions usually stimulate research and are necessary to progress. Any statement dealing with this problem is merely an expression of our knowledge of comparative morphology, and of our judgment concerning the phylogenetic importance of certain structures.

To my mind, the most conspicuous error in many schemes of phylogeny is the tendency to focus attention upon very few structures. It may be that the structures selected are the most significant, but the organism is a plexus of structures and must be considered in its totality. Very different structures have been laid hold of by the processes of evolution, and it may not be possible to relate the resulting forms properly upon the basis of any one or two structures. A conspicuous example is furnished by the liverworts, in which one line gave special attention to the structure of its gametophyte body, another to the form of its gametophyte body, a third to the struc-

MSS. intended for publication and books, etc., intended for review should be sent to the responsible editor, Professor J. McKeen Cattell, Garrison-on-Hudson, N. Y.

\* Address of the retiring President of the Botanical Society of America, delivered at Boston, August 19, 1897.



ture of its sporophyte body. Any attempt to relate these to one another upon the basis of a single structure, even so important a one as the sporogonium, is essentially misleading. But when we consider the totality of structure we are led to the opinion that these lines possibly diverged from an archetypal plexus in which there were gametophyte bodies as simple as that of *Aneura* and sporophyte bodies as simple as that of *Riccia*. Another illustration is the recent attempt of Arnoldi to associate *Isoetes* with *Selaginella* largely upon the basis of endosperm development, without regard to great diversities in habit and anatomical details. The association may be perfectly proper, but the reason given for it is inadequate.

In dealing with problems of phylogeny it is also important to remember that the origin of a prominent group of living forms from another group of living forms is extremely improbable. We can point out resemblances in structures which we have come to regard as essential, but this is not likely to mean the origin of the one group from the other. It may mean that the two groups can be traced to one, probably now extinct, which combined the characters now differentiated. Most living groups are best regarded as divergent rather than consecutive series.

But even this apparently sure ground has become very uncertain from the fact, becoming more and more apparent, that similar changes in structure, even very important ones, may have appeared independently in different lines. The response of organisms in structure to their environment is deeper seated than we were once inclined to believe, and testimony from the similarity of certain structures, when contradicted by the majority of other structures, argues feebly for recent community of origin. Such similarities in structure argue more for physiological conditions than for phylogeny. For

instance, from the standpoint of evolution, the appearance of heterospory among the pteridophytes is one of the most important contributions to plant progress made by the group, but it is impossible to escape the conclusion that heterospory was attained independently by several lines. To put into the same genetic group all heterosporous pteridophytes would be regarded as a morphological absurdity. If heterospory appeared independently in several lines the same conclusion must be reached in reference to its natural outcome, the seed, and the polyphyletic origin of the spermatophytes becomes extremely probable.

This increases the perplexities of phylogeny, but it broadens its horizon and introduces another possibility. To continue the same illustration, in our search for the origin of seed-plants we have narrowed attention to the existing heterosporous pteridophytes, when some of the spermatophyte groups, as, for example, the gymnosperms, may represent an entirely distinct line in which heterospory and then the seed appeared, and may not be related directly to any existing heterosporous pteridophyte. In such a case we are permitted to look to some group of living homosporous pteridophytes as possibly containing the best living representatives of the group from which gymnosperms have been derived.

With all these possibilities in mind, I wish to discuss the phylogeny of the gymnosperms, not so much to reach a clear phylogeny as a clearer understanding of the complexity of the problem and the uncertainty of conclusions. This is a field in which no one can afford to be dogmatic.

#### THE ORIGIN OF GYMNOSPERMS.

From Hofmeister's classic researches to the discovery of gymnosperm spermatozoids by Hirase, Ikeno and Webber, the fact has



become increasingly apparent that gymnosperms are very closely related to pteridophytes. It was natural, for a time, to regard gymnosperms as phylogenetically intermediate between pteridophytes and angiosperms, for it was not easy to believe that such a structure as the seed appeared in more than one genetic line; but it is probably not going too far to say that there is now no serious opposition to the view that the gymnosperm and angiosperm lines are genetically independent. However, such a discussion does not lie within the scope of this paper.

That gymnosperms have been derived from pteridophyte stock is hardly open to discussion; at least we must assume that this is true, or all attempts at phylogeny are useless. The first question which confronts us, therefore, is whether the very divergent gymnosperm lines have had a common origin in this pteridophyte stock or not. Was there a single group of archaic gymnosperms, derived from pteridophytes, which subsequently differentiated into distinct lines? The existing gymnosperm groups are so very diverse that one of two things seems evident: either they differentiated into divergent lines from a common gymnosperm stock in very ancient times, or they originated independently from the pteridophyte stock. From this discussion I wish to exclude the Gnetales, as we do not possess sufficient data concerning their early history, or concerning the morphology of the very dissimilar living forms, to justify any opinion as to their origin. They are such dissimilar fragments, living in such extreme conditions, that their origin is totally obscure. In some respects they are more cycad-like than conifer-like, but in most respects they are so unlike both that a separate origin seems possible. It may be even true that the three genera belong to groups of independent origin, which is certainly the easiest way of disposing of their

differences; and their common characters of true vessels, the so-called perianth and elongated micropyle, may have been attained independently as readily as heterospory; but the combination of characters in common does not seem to justify such a disposition of them, and the three genera had better be regarded as of common derivation, wonderfully diversified by ancient separation, isolation and extreme conditions.

Approaching the subject from the historical standpoint, the group *Cordaites* seems to be the first with sufficient data to justify consideration. The structure of the vascular bundles, especially those of the leaves, is said to suggest those of conifers, cycads, *Isoetes* and *Ophioglossum*; and the sporophylls are organized into a strobilus, a character common to pteridophytes and gymnosperms. But such characters can be used only as cumulative testimony. In such evidences as we have of the structure of the male gametophyte, however, we obtain some valuable suggestions. Within the mature microspore there appears a considerable group of polygonal cells. In living groups of gymnosperms, so far as investigated, there is no such structure; and if we look to pteridophytes for suggestion we are constrained to believe that this group of cells is either prothallial or sperm mother cells. In either event, it would represent a condition of things much nearer pteridophytes than is shown by any living seed plant. In view of the discovery of spermatozoids in *Cycas*, *Zamia* and *Ginkgo*, taken in connection with the peculiar structure of the male gametophyte just described, I am of the opinion that the *Cordaites* also developed spermatozoids. With either hypothesis as to the nature of the cells developed within the microspore of *Cordaites*, in seeking for the pteridophyte origin of the group, we are led away from such heterosporous pteridophytes as now exist, for in them the male gametophyte is much more reduced

than in Cordaites—in fact, more reduced than in most living cycads and conifers.

Additional testimony to the same effect is furnished by sections of the seeds of Cordaites. In addition to the remarkable nucellus beak, which probably has no phylogenetic significance, the large pollen chamber is a conspicuous feature. This is sometimes so extraordinarily large that it occupies the whole upper portion of the nucellus, and has been observed to contain numerous pollen grains. The pollen chamber is a well-known cycad feature, and seems to be associated with the early development of siphonogamy. By means of it, the tubular outgrowth from the antheridium wall is reduced to a minimum, and may coexist with spermatozoid development, as shown by Hirase, Ikeno and Webber.

The testimony all indicates that in Cordaites we have the beginnings of a siphonogamic line, brought about by the retention of the megaspore, which still develops its exine in Cordaites and some cycads.

As to the pteridophyte group from which the Cordaites were derived, data are not sufficient to make opinion other than a pure hypothesis. I think it is clear that such heterosporous pteridophytes as are living to day must be set aside in this search, by the testimony of both of their gametophytes, especially the male. They stand for lines which have very much reduced the male gametophyte, have variously modified the female gametophyte, but have not developed siphonogamy by retaining the megaspore. It may be that the lycopod forms of the Carboniferous and earlier formations represent the pteridophyte plexus from which Cordaites were derived, but we know too little of their morphology to make any assertion. My judgment is that the Cordaites represent an independent heterosporous line, and that if they were associated in origin with the lycopod forms at

all it was before the latter had developed heterospory, which seems never to have been extensively developed in the lycopod line until recent times.

I believe that we must regard either the ancient homosporous lycopod forms or the abundant Palaeozoic *Marattia* forms as responsible for the origin of Cordaites, and my own inclination is toward their *Marattia* origin, perhaps for no better reason than that in such an origin I see more opportunity for the development of such a group as cycads; but such a view is further supported by the discovery that the spermatozoids of cycads, and their ally, the *Ginkgo*, are of the multiciliate type, and not biciliate, as in living lycopod forms. Just what stress should be laid upon this I do not know, but when opinion is fairly balanced it would seem to help to a decision. It seems satisfactory, therefore, to regard the origin of cycads as from the homosporous-eusporangiate plexus of Filicales, represented to-day most abundantly by *Marattia* and its allies. It would seem, further, that this has been brought about without the intervention of such Cordaites as we recognize, which, with probably similar origin, were developing a very different type of body, which finds its modern expression in the conifers. In the acknowledged Cordaites, therefore, I recognize a transition region between the homosporous-eusporangiate plexus of Filicales and the more modern conifer series; while in the cycads we have a line which continued more of the fern habit and structure, recognizable not merely in its foliage leaves and general port, but in its occasional vascular bundles of eocentric type and its multiciliate spermatozoids. The Cordaites, however, must have included forms that we have not recognized as such, for it is only when they become differentiated from the fern habit that in the main we are able to distinguish them. This very fact of their sharp differ-

entiation means that they had made a decided departure, and we are probably able to recognize only the most highly specialized forms. Of course, in what I have said I may have been using the name Cordaites in a much more inclusive sense than taxonomy would justify. As ordinarily defined I would see in them the first distinct beginnings of a type which afterwards gave rise to the conifers; as used in this paper they refer to a plexus of forms derived from the homosporous-eusporangiate Filicales which gave rise to both cycads and conifers as divergent lines, one retaining more nearly the fern habit and structure and culminating earlier, the other departing more widely from the habit and structure and culminating later. I believe that some Palæozoic forms now regarded as ferns will be found to be more closely related to the Cordaites. How many other lines arose from this large Cordaites plexus, as I have defined it, we have no means of knowing, but it seems to be responsible at least for all of the living gymnosperm forms.

It is important to obtain such historical evidence as we can in reference to the gymnosperm lines, restricted in this paper to the Cordaites, conifers and cycads. If a historical sequence can be established which conforms to the views expressed here as to the interrelationship of these lines the conclusion will have additional support. I need not apologize for the paucity of data furnished by paleobotanists. They have done what they could, and we are greatly in their debt. Morphologists recognize, however, that the structures usually preserved are not the most convincing as to relationships, and that nowhere are appearances more deceitful. While we have no sympathy with wild generalizations based upon fragmentary material, there is an increasing accumulation of data which furnishes a substantial foundation for some conclusions. It seems to be clear that dur-

ing the Palæozoic there was an increasing display of gymnosperms. The fragments which bear this testimony became very abundant in the later periods of the Palæozoic, and are regarded, for the most part, as Cordaites. Associated with these forms is the great display of *Marattia* and its allies. A distinct type of leaf and of stem is attributed to each of these great groups, and when seeds or sporangia are associated with them the case seems clear enough, but apart from such association the uncertainty is profound. Intergrading forms between the two are to be expected, but with material so fragmentary and non-committal it would be a rare chance that would lead to its definite demonstration. In the Coal Measures the cycad type becomes apparent, but not prominent. This would seem to indicate either an early differentiation from the Cordaites plexus or a late differentiation from the *Marattia* plexus. I see no difficulty in the former view, as I see no advantage in multiplying the independent heterosporous and seed lines until forced to do so by incontrovertible evidence. The domination of cycads during the Mesozoic and their subsequent decline are well-known facts.

More suggestive, however, is the history of the conifers. It is generally stated that this line, in its modern expression, began during the Palæozoic, and that our modern genera have been recognized by stem and leaf anatomy. Such methods of determination we know to be untrustworthy, as there is the greatest possible amount of anatomical diversity even in contiguous regions of the same organ, much more in different organs and at different ages. In examining the claim that modern coniferous genera appeared during the Coal Measures, I find no evidence that seems to be worthy of serious consideration excepting that with reference to *Ginkgo*, and it is an interesting fact that *Ginkgo* is no longer regarded



as a conifer. Long before the evidence of spermatozoids was discovered it seemed perfectly clear to me that Ginkgo was more cycad-like than conifer-like. In the light of our present knowledge the appearance of Ginkgo in association with the Carboniferous cycads seems natural enough. It is a matter of very secondary importance whether we are to regard it as an independent line or not. I am inclined to believe that, while during the Palæozoic heterosporous and the seed were both attained, siphonogamy was in its beginnings, and that the spermatozoid habit was for the most part still continued in the seed line. There is no conclusive evidence, therefore, that any of our modern coniferous genera appeared during the Palæozoic, during which the Cordaites were the dominating seed plants. During the last Palæozoic periods undoubted conifers did appear, and in considerable abundance, and we may recognize the beginnings of distinct lines represented to-day by *Abies* and its allies, *Taxodium* and its allies, and *Taxus* and its allies, but the genera are not those of to-day. In the lower Mesozoic, however, modern araucarian and abietinous genera appear; and the *Taxodium* and *Taxus* lines become more distinct, but not modern until the later Mesozoic. At that time *Cupressus* forms also appear, but not of modern genera. Further details are not necessary, as the point to be made is that the conifer type was not recognizable until late in the Palæozoic, and then not in its modern expression. It certainly suggests a later departure from the Cordaites stock than do the cycads.

Another fact is interesting to note in connection with the evolution of the conifer forms. In existing conifers there is considerable variation in the development of the male gametophyte. In some forms, as the Abietineæ, the development of two or three prothallial cells, distinct from the large antheridial cell, is a well-known fact,

an amount of prothallial development not shown by any other living heterosporous forms, even the heterosporous pteridophytes. In other forms, as Cupressineæ and Taxeæ, the reduction of the male gametophyte is greater, no sterile prothallial cells appearing, the whole structure being an antheridium, as in the angiosperms. Our historical evidence accords with this progressive reduction of the male gametophyte, the *Taxus* and *Cupressus* lines having attained modern expression after the *Abies* line; and back of the *Abies* line we find the Cordaites, with probably a still greater development of the sterile region of the male gametophyte indicated. To derive the Cordaites or *Abies* lines, with their two or three to many-celled sterile tissue of the male gametophyte, from such heterosporous lycopod forms as we know to-day, with their constantly more reduced male gametophytes, is not within the bounds of probability. Besides, the reduction of the male gametophyte seems to be so prompt a response to heterosporous that its partially reduced condition in certain conifers, and probably in Cordaites, would seem to argue for their near derivation from some homosporous type.

The development of a suspensor in the lycopod forms has also suggested a genetic connection with gymnosperms, in which the suspensor development is so conspicuous. This organ, however, seems to have no morphological constancy. In gymnosperms it may be developed from a plate of cells formed in the oospore, as in most conifers; or from a mass of cells formed basally or parietally in the oospore, as in cycads; or from free cells formed within the oospore, as in *Ephedra*; or from the elongation of the oospore itself, as in *Gnetum*; or from the downward elongation of the archegonium, as in *Welwitschia*. The suspensor, therefore, seems to be a temporary organ of the embryo, of various morphological origin,



intended to relate the embryo properly to its food supply, and not of phylogenetic significance.

The testimony of history and morphology seem to combine in pointing to a very generalized Palæozoic type as the origin of gymnosperms. This type is characterized by its advancement towards seed production rather than by its habit, which must have been extremely varied to have given rise to such types as cycads and conifers. The usually recognized Cordaites show but one tendency of a much more extensive group, for which the name Cordaites may be extended for convenience. Cordaites in this larger sense occur in such association with groups of homosporous eusporangiate Filicales, and approach them so much nearer in the important morphological structures mentioned than they do living heterosporous Filicales, that an independent heterosporous line is suggested. If such be the case, in the passage from the Marattia forms to the Cordaites forms both heterospory and the retention of the megaspore were attained, and probably siphonogamy begun.

#### THE SEED HABIT.

The evolution of heterospory seems simple enough. The physiological differentiation of the spores was complete when prothallia became persistently dioecious. This division of labor is to be expected in the case of two such distinct functions as the production of antheridia and archegonia. A prothallium producing both sex organs equally well may be regarded as in a state of equilibrium, an equilibrium which is disturbed by any conditions which favor the production of one sex organ rather than the other, in this case probably nutritive conditions. This disturbance of the equilibrium of a bisexual prothallium would certainly find an expression first in a dioecious tendency, and finally in a dioecious habit. With the habit once

fixed the morphological differentiation of spores becomes inevitable, since the nutritive requirements of the two prothallia are so different. The evolution of heterospory seems to be one of the simplest of selective processes, with inequalities of nutrition to furnish the variations. From this point of view it would seem natural to expect that it may have been derived frequently from homospory.

The retention of the megaspore, however, does not seem to be so simple a problem. In a certain sense it is correlated with the reduction of the gametophyte, since retention would not seem practicable until reduction had proceeded far enough to make the gametophyte endosporic. Even greater reduction, however, is attained by the male gametophyte, but the spore is shed. It should be noted that even in the case of the microspore the male gametophyte is usually completely organized before pollination, but the fact remains that reduction does not compel retention. It has seemed to me that this phenomenon is to be explained by Bower's law of sterilization, developed in reference to the strobilus. This law certainly finds expression in the megasporangia of heterosporous pteridophytes, in which the sterilization of mother cells is conspicuous. This method of increasing the nutrition of the fertile cells is too common a phenomenon to need illustration; but it is a tendency that would seem very consistent with the development of megaspores, whose peculiar work holds so definite a relation to abundant nutrition. For this very reason high numbers of microspores may be continued, and a diminishing number of megaspores produced. This would reach its culmination in the production of but a single megaspore by a sporangium, and a proportionate increase in the size of the megaspore. With the development of a single spore imbedded in sterile tissue, shedding becomes not only mechanically

difficult, but meaningless, since the necessity of scattering a brood of gametophytes, to avoid competition, has disappeared. It is further true that the development of such a spore involves nutritive supplies from numerous neighboring cells, and a certain amount of retention becomes necessary for this reason. Still further, the advantage to a single megaspore in being retained, thus securing more abundant outside nutrition during germination, would fix the habit if any selective process were at work. For these various reasons it would seem evident that when the sterilization of a megasporangium had reached its extreme limit, by organizing a single spore, retention is likely to follow sooner or later. If this line of reasoning be true the seed habit might have been developed in any heterosporous line.

With the retention of the megaspore pollination became necessary, but its gymnosperm expression differs in no way from the scattering of aerial spores in all the lower groups. The new feature demanded by the retention of the megaspore, therefore, was not the scattering of the microspores, but the development of siphonogamy. That the first retained megaspores were exposed to the microspores can hardly be doubted, and in such cases we now know that the spermatozoid habit must have been retained, and that no tube, or a very small protuberance of the antheridium wall, was needed to discharge the spermatozooids sufficiently near the oosphere. If chemotropism can explain the guidance of a pollen tube through much intervening tissue it would certainly be sufficient to cause the protrusion of an elastic antheridial wall. In the very few illustrations of *Cordaites* obtained, the megaspore is but slightly covered by sterile tissue at the bottom of a deep pollen chamber, and a very slight development of tube is necessary. The same condition is continued in the cycads, and thus the habit of siphonogamy] may have been gradually

built up. As siphonogamy developed, the gradual failure of the sperm mother cells to organize spermatozooids followed, and presently, almost exclusively now in gymnosperms, sperm mother cells are found to function directly as male gametes without further organization.

The secondary results which followed the retention of the megaspore were numerous. The well-known effect of fertilization upon adjacent tissues necessarily involved at least the sporangium, and the seed resulted. The presence of abundant available nutrition and favorable conditions induced the immediate germination of the spore, which the development of a resistant tissue about the sporangium checked. As a consequence, the development of the embryo was thrown into two stages, the intra-seminal and the extra-seminal.

In the case of the angiosperms, however, another tendency was connected with the retention of the megaspore, namely, the tendency of the sporophyll to enclose the megasporangium, a tendency so evident in such pteridophytes as *Isoetes* and *Marsilea* that the direct pteridophyte origin of the group seems more natural than an origin from so specialized a type as the gymnosperms. Given the reduction of spore production to a single megaspore and the persistent enclosure of the sporangium by the sporophyll, and the angiosperm peculiarities follow. The profound effect of these conditions upon the germination of the megaspore is so remarkable, and the intergrading stages are so completely unknown, that there seems to be no clue to the sequence of changes. That an endosporic gametophyte might eliminate the archegonium seems evident, for the tendency is shown among gymnosperms by *Gnetum*, where oospheres are organized by free endosperm cells. That the reproductive region of the female gametophyte may be organized earlier than the nutritive region, when the

gametophyte is supplied with outside nourishment by the retention of the megaspore, is hinted at among the heterosporous pteridophytes and gymnosperms. These tendencies have found full expression in the angiosperms, where archegonia have disappeared and the reproductive tissue of the female gametophyte is persistently organized before the nutritive tissue. Evidence as to the details of the evolution of this tendency is lacking and may not be in existence, but the tendency has certainly reached a remarkably definite expression. The unvaried appearance and movement of eight free nuclei or cells, and the remarkable fusion of two of them, represent habits so fixed through such an enormous group that they baffle explanation, and argue both for the monophyletic origin of angiosperms, and against their derivation from so divergent a line as gymnosperms.

The earlier evolution of the gymnosperm line is probably to be explained by ecological conditions. The body as a rule is organized to endure extreme conditions. It is certainly not a mesophytic type, and its evolution was certainly not in response to prevailing mesophytic conditions. On the contrary, the angiosperm type is essentially a mesophytic one, with great foliage display, and probably expanded in response to widely prevalent mesophytic conditions. This might explain the habit peculiarities of the two groups, but whether the more recondite morphological differences hold any relation to these or not is too obscure to permit even speculation.

#### SUMMARY.

1. A great *Cordaites* plexus, more extensive than the one usually included under that name, represented the characteristic Palæozoic seed plants.

2. It was probably derived from homosporous-eusporangiate Filicales, represented to-day most abundantly by the *Marattia*

forms and their allies, and was the most common Palæozoic type of Filicales.

3. From it the gymnosperm lines, at least the cycads and conifers, were derived, the usually recognized *Cordaites* representing a transition stage towards conifers.

4. The frequent independent appearance of heterospory is to be expected, as it probably results from inequalities of nutrition in connection with the development of antheridia and archegonia.

5. The retention of the megaspore, resulting in the seed habit, follows the extreme sterilization of the megasporangium, which is attained with the organization of but one megaspore. With the development of a single megaspore imbedded in sterile tissue shedding becomes mechanically difficult, unnecessary, and even disadvantageous from the standpoint of nutrition.

6. The retention of the megaspore was followed by the development of seed coats, possibly through the well-known effect of fertilization upon adjacent tissues; by immediate germination of the oospore, on account of the favorable conditions and the abundant supply of available nutrition; and by the checking of the developing embryo by the mature seed structures, resulting in the characteristic intra-seminal and extra-seminal stages of germination.

7. The first retained megaspores were doubtless directly exposed to the microspores, and in *Cordaites* and cycads a pollen chamber of varying depth and extent is associated with the early stages of siphonogamy, with which the spermatozoid habit was more or less associated.

8. The pollination of gymnosperms is but a continuation of the ordinary method of dispersing aerial spores employed by cryptogams, the chief result of the retention of the megaspore upon the male gametophyte being the development of siphonogamy.

JOHN M. COULTER.

UNIVERSITY OF CHICAGO.



*THE DEVELOPMENT OF PHOTOGRAPHY IN ASTRONOMY (II).\**

THE great nebula of Andromeda has been known to astronomers for upwards of a thousand years, as it is a rather noticeable object with the naked eye. It has received its full share of attention ever since the invention of the telescope. It also appears to be a vast body of gaseous matter shining far away in the depths of space, but it seems to be in a different condition from that of the great nebula of Orion, for its spectrum is continuous and does not show the bright lines, indicating an incandescent gas, which are present in the spectrum of the Orion nebula. Though the mystery of its physical condition has not yet been solved, photography has at least shown us its true form. It has ceased to be the long spindle-shaped body of the elder Herschel, or the broad irregular object, with two dark parallel channels in one side, as drawn by the Bonds and Trouvelot. The photographic plate reveals to us in their place a beautiful symmetrical mass of nebulous matter, surrounded with several more or less concentric rings, claimed by some astronomers to be a representation of the nebular hypothesis of La Place in full operation. The first picture to show the true form of this wonderful object was taken in 1885, with a 20-inch reflector, by Roberts. It does not, however, require a powerful photographic telescope to show its peculiar features, for a 6-inch portrait lens will show the rings well with anything above one hour's exposure.

Important photographs of some of the spiral nebulae, and especially of the 'whirlpool nebula' of Lord Rosse, were made as early as 1888, by von Gothard, with a 10-inch reflector. Excellent photographs

of these objects have also been obtained by Dr. Roberts.

While it is absolutely necessary to use a considerable photographic telescope for the accurate registration of star positions, etc., where measures of precision are required, there are a great number of objects in the sky which are not necessarily subject to measurement, and which for their greatest value require a simple pictorial representation. The Milky Way, one of the most beautiful and certainly the most stupendous of the celestial features, is not susceptible of accurate measurement. The individualizing and measurement of all its stars would be the most hopeless task imaginable. Nor would such a task be of any very great importance could it be accomplished as a whole, for we could not form any special idea of its structural peculiarities from such a work. Though a conspicuous object to the unaided eye, the view we thus get of it is not sufficiently tangible, from the lack of details, to enable one to form any more than a crude idea of its coarser features. But even the naked-eye view of it is far more comprehensive than a catalogue would be containing accurate determinations of all its individual stars. What is required, therefore, in the study of this wonderful object—this mighty universe of stars—is something that will increase the penetration of our vision, and at the same time give us a certain amount of accuracy of position with a large field of view, so that we may study its peculiarities of structure in detail, and at the same time closely locate these details with reference to the whole, and thus, by finally putting structure and detail together, form a comprehensive idea, not only of the details themselves, but also of the relation of these features to each other. The long-focus telescope with a very limited field is not capable of dealing with the Milky Way in the manner stated. Its structural details are very large, far larger

\*Address of the Vice-President before Section A—Mathematics and Astronomy—of the American Association for the Advancement of Science, August 22, 1898.



in general than the field of view of the ordinary photographic telescope, and vastly greater than that of a powerful visual telescope. We want, therefore, a short focus instrument, one capable not only of taking in a wide part of the sky, but also of giving a brilliant image, or, in other words, the reduction of the large details to a smaller scale, with a correspondingly great increase of effective light-power. These conditions exist in the large portrait lenses which were needed in the early days of photography to reduce the exposure time by collecting a great quantity of light from the object, and which in these days of rapid dry plates are no longer required for portrait work. Taking in some ten or twelve degrees of the sky, these lenses are specially suitable for photographing large surfaces, such as are presented by the Milky Way.

This subject was taken up by the writer in the first part of 1889 at the Lick Observatory, with a large 6-inch portrait lens of 31 inches focus, and with it was inaugurated the photography of the Milky Way. The first picture to show the real structure of the Milky Way was made in 1889, with this instrument. In the few following years a large series of photographs of those portions of the Milky Way seen from the northern hemisphere was made. The work with similar instruments was next taken up by Dr. Max Wolf, in Germany, who has also succeeded in making excellent pictures of the Milky Way. Mr. Russell, of Sydney, New South Wales, has also photographed portions of the southern part of the Milky Way, with a large portrait lens. Those who have seen some of the Milky Way photographs taken with the regular Astro-Photographic telescope, or who have tried to make out its complex structure with a visual telescope, must be struck with the great beauty of a photograph made with one of these short focus portrait lenses.

The extraordinary complexity of structure of the Milky Way is brought out with marvellous beauty of detail, and the peculiarities of its different portions can be traced and connected in the different photographs, which thus afford the most direct means for studying every feature of structure and detail. These pictures show many peculiarities which must materially alter our ideas of the constitution and structure of the Milky Way. Some of them show strong evidence that the general body of the Milky Way may be made up of small stars which are not at all comparable with our sun in dimensions. This is especially shown in the region of the star Rho Ophiuchi. Many parts of the Milky Way appear to be comparatively thin sheetings of stars with relatively no very great depth, for it is not possible otherwise to explain the black holes and rifts shown in them. One of the most important revelations made by the portrait lens in connection with the Milky Way is the presence in it of very diffused nebulous matter apparently freely mixed with the groundwork of stars, and seemingly showing no definite tendency to condensation about the individual stars. These photographic nebulosities of the Milky Way are apparently of a different nature from the ordinary nebulae of the sky, since they are extraordinarily large, diffused and but feebly luminous. These nebulous regions seem to be peculiar to the Milky Way and its vicinity, and are certainly in some way physically connected with it. It will be in the study by photography of such regions that we shall finally clear away some of the mysteries of the Milky Way. These masses of diffused nebulosity mainly affect regions of the sky in Scorpio, Cygnus, Cepheus, Perseus and Monoceros. I believe it to be true that no other form of telescope but the old time portrait lens or similar combination is capable of dealing with these extraordinary objects.

It was not until the study of the peculiarities of comet tails with portrait lenses that we knew anything of the strange phenomena shown by them. It may be said that our knowledge of the extremely rapid transformations in the tails of comets dates from the photographs of Swift's comet of 1892, taken at the Lick Observatory with the lens previously mentioned and similar ones taken of the same object by Professor Pickering at Arequipa, Peru. Although the great comet of 1882 was successfully photographed, it showed no phenomena not known and already seen with the telescope. While only an insignificant affair visually, and but fairly visible to the naked eye, Swift's comet showed upon the photographic plates the most extraordinary and rapid transformations yet seen in any comet. One day its tail would be separated into at least a dozen individual streams and the next present only two broad streamers, which a day later had again separated into numerous strands, with a great mass, apparently a secondary comet, appearing some distance back of the head in the main tail, with a system of tails of its own. This remarkable appearance was the first known of its kind, though it was repeated in the photographs of Rordame's comet of 1893 taken by Professor Hussey. These peculiar phenomena seem to be a production of the comet itself—a result of the forces at work in the head of the comet.

The photographs of Brooks' comet of 1893, also secured with the Willard lens, showed such an extraordinary condition of change and distortion in the tail as to suggest some outside influence, such as the probable collision of the tail with some resisting medium, possibly a stream of meteors, such as we know exist in space. The long series of photographs obtained of this comet frequently showed great masses of cometary matter drifting away into space, probably to become meteor swarms. One

of the pictures showed the tail of the comet streaming irregularly as if beating against a resisting medium and sharply bent at right angles near the end, as if at that point it encountered a stronger current of resistance. All of these wonderful phenomena would have been unknown to astronomers had it not been for these photographs, and the comet, instead of proving to be one of the most remarkable on record, would have passed without special notice. Though these phenomena were so conspicuously shown, scarcely any trace of the disturbance was visible with the telescope. On account of the apparent insignificance of the comet visually, no photographs were made of it elsewhere during its active period.

In the matter of discovery the photographic plate has accomplished a very great amount in certain directions. In spectroscopic work it has a field singularly suited to display its possibilities. In this direction it deals not alone with what can be seen, but it enters into the unseeable regions where the eye takes no cognizance of things. For though it is partly blind to the light which affects the eye, it can readily penetrate regions where we in turn are blind. And it is in this direction mainly where the photographic discoveries in spectrum analysis are immediately concerned, since it extends our vision into the invisible regions of the spectrum. The result must necessarily be one of discovery. It not only faithfully records spectral lines that cannot otherwise be seen, but by special treatment of the plate it also registers those visible to the eye and permits their accurate measurement.

From Doppler's principle it is known that the spectral lines have a normal position only while the object whose light is under examination is motionless in the line of sight. When it is in motion to or from us these lines are displaced from their normal position, in the first case towards the violet region of the spectrum, and in

the other towards the red. By comparing any of the lines in the spectrum of a heavenly body with the same lines in the spectrum of a stationary object it is possible to tell not only the direction of motion of the moving object, but to determine accurately the amount of this motion, for there is a known relation between the amount of displacement and the actual velocity, and this is independent of the distance.

This peculiarity, besides showing the motions of the individual stars, has revealed to us, through the aid of photography, an entirely new class of bodies, the so-called spectroscopic binaries.

The visual spectroscopic work, long ago, in the hands of Dr. Huggins, had shown the displacement of the spectral lines as the stars moved towards or from us. It remained, however, for photography further to extend this remarkable work by showing that not only were the lines displaced, but that in the case of certain of the stars the lines were periodically doubled at short intervals, thus indicating the presence of two bodies which must be rapidly revolving about each other. The doubling of the lines is due to the alternate approach of one and recession of the other body, which thus causes a displacement of the two sets of spectra, for when the motion is at right angles to the line of sight (and this must occur at two points in the orbit) the two spectra will be exactly superposed. It can readily be shown from the known periods of these stars and their enormous distances that no telescope is likely to be made so powerful as to show visually their independent components. The visual double star having the shortest period is one discovered by Burnham, and known as Kappa Pegasi, which he found to have a period of about eleven years. The spectroscopic binaries seem to revolve in extremely short periods—a few days—and in at least one case in a few hours, showing

that they must be extremely close to each other. The explanation, to account for the observed peculiarities of their spectra, that these are actual double stars in rapid orbital motion must be accepted until some better explanation of the phenomenon be forthcoming, which does not at present seem likely to occur.

Among the first of these spectroscopic binaries discovered was Beta Aurigæ, which was detected at the Harvard College Observatory by Miss Maury, through the doubling of its spectral lines as shown on the various photographs obtained of it at that Observatory. This star has a period of four days, the relative motion of the components about each other being about 150 miles a second, and the distance between them about six millions of miles. In a similar manner, Dr. Vogel has found that the star Algol, so famous for its light variations, alternately approaches us and recedes, in a manner that can only be explained at present by the revolution of that star about some other body or about the center of gravity of the two. The spectrum of this star does not show any doubling of the lines, but a simple displacement from one side to the other of their normal position occurs consistent with the changes of the star's light. As there is no doubling of the lines, the conclusion is that there is but one spectrum. One of the stars is, therefore, a non-luminous body, and hence produces no spectrum. The old explanation of two hundred years ago, that the variation in the light of Algol is due to a dark body revolving about it and partially eclipsing it at intervals of a little less than three days, is hence proved by the spectroscope and photography to be the correct one. The frequent discovery of these spectroscopic binaries shows that they are by no means uncommon, and that possibly a considerable percentage of the stars consist of two or more bodies rapidly whirling about each other.



The beautiful phenomenon of the displacement of the spectral lines through motion in the line of sight has given rise to many important and interesting results, but certainly none more striking than that offered by Professor Keeler's spectroscopic proof of the meteoric constitution of the rings of Saturn. It was suggested soon after the discovery of the rings that they must be made up of discrete particles revolving in zones about the planet, which, from their smallness and great distance from us, gave the appearance of a system of solid rings encircling Saturn. This had been shown by Clerk Maxwell to be a mathematical necessity, and as the rings lay within Roche's limit, within which a large solid body would be broken up in revolving about a planet by the unequal attraction of the planet itself, it was certain that the rings must consist of small individual bodies. It remained for the spectroscopist, through the aid of photography, to add its testimony to that of mathematical analysis. The problem offered to the spectroscopist was simply to show whether the inner or the outer portion of the rings moved the faster. Should they revolve as a solid body the outer edge must necessarily have the greater velocity. But if they are made up of individual particles, then the attraction of the planet would cause those nearest to it to move the fastest, or, in other words, the inner part of the rings must have the greater velocity. This beautiful problem was successfully solved by the photographs of the spectrum of the rings obtained by Professor Keeler, where the displacement of the spectral lines by motion in the line of sight showed that the inner portion of the rings moved faster than the outer, and hence that the rings must consist of small bodies responding individually to the attraction of the planet.

The discovery of variable stars by photography can be compared with the wholesale

business in commercial circles, because of the great number that are found on the various plates. These stars are not only found by the actual variation of their light, as shown by the size of their images on different plates, but many of them also show peculiarities in their spectra which at once stamp them as being members of a certain class of variable stars. So expert has Mrs. Fleming, of the Harvard College Observatory, become in detecting these bodies by their spectra that she instantly recognizes them at a glance among hundreds of other spectra on the same plate.

The most interesting and important of these Harvard College variable-star discoveries are found in the photographs of the globular clusters taken by Professor Bailey with the 13-inch telescope at Arequipa, Peru. It was found that a great many of the small stars that make up these clusters varied regularly and rapidly in their light, and in some cases a large percentage of the entire mass of stars was variable. So abundant are these variables, indeed, that as many as a hundred of them have been found in a space in the sky that would be covered by a pin's head held at the distance of distinct vision.

The clusters most prolific in variables are M 3, Omega Centauri, M 5, and a few others of this class. Perhaps the most remarkable circumstance, outside of the actual grouping of variables in such great numbers, is the fact that not a single variable star has been found in the great cluster of Hercules, the best known of these objects, and apparently like them in all other respects. Professor Pickering finds every star in this cluster constant in its light from the photographic evidence extending through ten years.\* This would seem to mark this great cluster as being physically very different from the others referred to.

\* Professor Bailey has since found that two of the stars of this cluster are slightly variable.

The writer has examined the cluster M 5 with the great telescope of the Yerkes Observatory and has visually verified a number of these variables. The brighter of them appear to vary slowly in their light, while many of the smaller ones are extremely rapid, passing through their entire light changes in a few hours. In the discovery of such objects, photography offers special advantages, since on the different photographs a thousand or more stars can be rapidly and accurately compared with each other and any variation in their light at once detected, while such comparisons in the actual sky, visually, would be limited to a very few stars. By the aid of the Harvard photographic plates over five hundred variable stars have been discovered in these clusters. It must be said, however, in speaking of the variables in the cluster M 5, that the two most prominent ones were really discovered visually nearly ten years ago by Mr. D. Packer with a very small telescope. These two seem to have been the first of the variable stars found in this cluster.

The shortest period variable so far discovered in the globular clusters—indeed, the shortest known variable—is a small star in the great southern cluster Omega Centauri, whose period is seven hours. These cluster variables seem to form a distinct class from the ordinary variable stars. It is very interesting to watch one of these small stars in a powerful telescope and to see with what quickness it passes through its light variation. One of the small stars in M 5, whose period is 12 h. 31 m., seems to be dormant for a large part of the time, as a very faint star, invisible in ordinary telescopes. It begins to brighten, and in two or three hours has risen nearly two magnitudes and faded again to its normal condition, while another and larger star quite near it seems to require a month or more to go through its light fluctuation.

Frequent reference has been made to the photographic work of the Harvard College Observatory. It is to be regretted that time does not permit a more detailed account of this work. No other observatory is so active in the application of photography to the various departments of astronomy. Not content with the available sky as seen from the northern hemisphere, Professor Pickering wisely established a branch observatory at Arequipa, in Peru, where a thorough photographic survey of the southern skies has been made, and a vast amount of work of high value has been accomplished, which has resulted in many important discoveries among the southern stars.

In dealing with the ordinary stars of the sky it has been shown that measures of the relative positions of the photographic images are strictly comparable with the best meridian circle work, while the number of stars that can be measured is vastly greater. The Pleiades, the cluster of Perseus, Præsepe in Cancer, etc., have all been measured with the micrometer, the heliometer and by photography. The comparisons have shown that photography has many advantages over the older methods, and the results are possibly even more accurate. These objects, however, are loose clusters, and the stars are not thickly crowded, and, moreover, the small scale of the photographic plate in such cases does not seriously interfere with the work. The great globular clusters of the sky, however, from the extraordinarily crowded condition of their stars, would almost forbid any attempt to deal with the individual positions by photography, except in outlying regions, where the stars are thinly scattered. No comparison between photographic and visual measures of such objects has yet been made, because no visual measures exist. The great cluster of Hercules is, perhaps, the easiest of these objects, both visually and photograph-

ically. It requires, however, a powerful telescope to measure the individual stars. Dr. Scheiner has given a catalogue of 833 of the stars of this cluster measured on photographs taken with the 13-inch refractor of the Potsdam Observatory. The stars that were measured all lie between the magnitudes 11.7 and 14. As a matter of comparison with visual measures, the writer has taken up the measurement of a few of the stars contained in Scheiner's catalogue. A rough inspection of the results so far obtained shows a close agreement between the visual and the photographic work. These observations also show that no appreciable change has taken place in the positions of any of the stars in the past six years, which, perhaps, is surprising, since one would expect a possible rapid change in some of the positions of the individual stars when they are massed so close together. They, however, seem to be as stable in their relative positions as are the stars elsewhere in the sky. A more remarkable object with a great telescope is the cluster Messier 5, in which the stars are more closely compressed and irresolvable than in the cluster of Hercules. This object has already been mentioned in speaking of the variable stars discovered at the Harvard College Observatory. The measurement of nearly 100 of these small stars has been undertaken with the great telescope of the Yerkes Observatory. Many of them are apparently in the very heart of the cluster, where the compression is the greatest. It is doubtful if at this time photographs can be made of this cluster upon which the crowded individual stars can be accurately measured.

It has been frequently photographed, but no measures have been made of the great mass of stars in the center of the cluster. It has been already stated that the accuracy of the photographic positions of individual stars is as great as the best meridian observations. The facility and

ease with which the photographic positions are obtained is well shown in a report by Professor H. H. Turner, who is making the Oxford portion of the great Astrophysical catalogue. An average of 3,951 measures per week is obtained. Over 150 stars per hour each can be measured by those most skilled in this work.

In the discovery of nebulae, variable stars and asteroids, the photographic plate has done a great work which is still being carried on. The number of known asteroids has been doubled in the past few years (as many as nine have been found in a single night), and now it has become a matter of impossibility to keep track of them all, and they are found and turned adrift again unless they show some striking peculiarity of orbit.

Up to the present time but two comets have been discovered by photography. The first of these was discovered on a photographic plate taken by the writer on October 12, 1892, with the 6-inch Willard lens of the Lick Observatory, and was subsequently verified visually and observed at the different observatories. The second was photographed at the same Observatory by Mr. Coddington, with the same instrument, in July, 1898.

In photographing the sky it is found that the short focus portrait lens, from its small scale and large field, will show faint nebulosities beyond the reach of the larger photographic telescopes. This results from various causes. The action of these lenses upon the Milky Way, comet's tails and the great nebulosities of the sky does not seem to be strictly subject in practice to the law of the ratio of aperture to focus; or, if it is, this law must be somewhat modified in effect. The action seems to be quicker with the short focus lens than it should be. Probably, however, much of this is due to the small scale and the consequent compression of the image



into a smaller space, which would produce an intensification of its action. It is possible, also, that the photographic plate may be relatively more active with a bright image than with a faint one, which would give an advantage to the small relatively bright image of the portrait lens. This idea seems to be partly borne out by some experiments with a small lantern lens. This lens,  $1\frac{1}{2}$  inches in diameter and about  $5\frac{1}{2}$  inches focus, is much quicker than its ratio would warrant, for it will photograph in a few minutes what the ordinary quick-acting portrait lens would require several hours to show. This was strikingly shown in photographs taken with it of the Milky Way. The scale of this lens is very small, and the cloud forms are so compressed that they act as a surface, and not as an aggregation of individual stars, as they must do in a larger telescope. If the focus is increased, the stars are scattered and the cloud no longer acts as a surface. With this small lens the earth-lit portion of the new moon was readily photographed in a single second, while with a 6-inch portrait lens of ratio  $\frac{1}{6}$  from 20 to 30 seconds were required to show it well. The brighter cloud forms of the Milky Way were shown in from 10 to 15 minutes' time, while with the larger lens upward of three hours were required. Some of the diffused nebulosities of the Milky Way, notably in the region of Antares, are shown more quickly and more satisfactorily with this small lens, and a great wing-like nebula involving the star Nu Scorpio was discovered with it.

A list of discoveries made with these small lenses would be tedious; one of the most interesting, however, cannot be passed over because of its importance. There is no object in the entire heavens better known than the great nebula of Orion. With the lantern lens, a great curved stream of nebulosity was shown on the plates of this region covering a large portion of the constellation

and some  $17^\circ$  long. It was found later that this had already been discovered by Professor Wm. H. Pickering with a  $2\frac{1}{2}$ -inch lens in 1889. This object seems to be an outlying appendage of the great nebula. The discovery very much extends our knowledge of the complicated and far-reaching influence of this mysterious object. In several other cases the photographic plate has shown us that the nebulæ are far vaster than we had ever conceived them to be, for their fainter extensions are not seen by the eye. What this knowledge may ultimately lead to in the reconstruction of our ideas of space and its contents can hardly be anticipated just now, though it must, necessarily, very greatly influence those ideas.

We have spoken of the Pleiades and the entangling nebulosities shown by photography to involve the stars of the cluster. The portrait lens has shown us that not only are the individual stars of this group involved in a nebulous system, but that streams and masses of this filmy matter stretch out for great distances all about the cluster.

The photographic plate has shown itself especially adapted, when used with the rapid portrait lens, for the accurate registering of the paths of meteors, and it promises to be of special value during the expected return of the November meteors this year, when a more exact determination of the radiant will be obtained from the photographs, and hence the orbit of the meteor stream will be better known.

In the reduction of the measures of the photographic plates for the great Cape Photographic Durchmusterung, Kapteyn discovered another 'runaway' star with a proper motion of 8.71 seconds a year, which is much greater than that of the celebrated 1830 Groombridge, and is at present the largest proper motion of any known star.

There are very few departments of as-

tronomy where photography has not taken a prominent, if not a commanding position. It is probable, however, that it will never take the place of the micrometer in the observation of close double stars, and in this direction the micrometer of Burnham will perhaps never be displaced. The photography of the surface features of the planets is in an almost hopeless condition at present, yet much can be expected in this direction when an increased sensitiveness of the plates has been secured.

Photography has shown its value in the determination of stellar parallax, and probably hereafter it will essentially take the place of the micrometer in this direction.

This is not the place to go into a discussion of the relative values of the refractor and reflector for photographic work. Where accurate measurement is to be considered, the refractor is doubtless better than the reflector. If, however, the main object is a great quantity of light, such as is required for the photography of the nebulae, the large aperture of the reflecting telescope of short focus makes it, perhaps, the best form of instrument (though it is very much hampered by its small field). This has been shown to be true by Common and Roberts. Since in the reflector the light does not pass through the glass, it is possible to use very large apertures without any additional loss of light through absorption, as would necessarily occur if it passed through a large object glass.

Mr. Ritchey, of the Yerkes Observatory, is making a large glass speculum, five feet in diameter and twenty-five feet focus, which, when finished, will be one of the most powerful instruments for photographic and spectroscopic work yet made, and which deserves a more extended notice than my limited time will permit me to give it here. With this instrument, and Mr. Ritchey's skill in photographic work, results of high importance will be obtained.

Through the intelligent generosity of Miss Catherine W. Bruce, of New York City, astronomical photography has been placed on a firmer basis than it ever was before. Her gifts have been made to all departments of astronomy, and it would take considerable space to properly enumerate them all. Perhaps the most important of these are the ones that bear directly upon astronomical photography.

The first of these gifts was the great 24-inch photographic doublet by the late Alvan Clark, presented to the Harvard College Observatory, and which is now doing such excellent work in Peru; the two 15-inch portrait lenses for Dr. Max Wolf, of Germany, and a 10-inch photographic doublet for the Yerkes Observatory. These instruments are the most powerful of their kind, and for certain classes of work are superior to any other form of telescope. The results of the splendid gifts of this lady must hereafter have the greatest influence upon the higher development of astronomical photography.

It is impossible within the limits of this address to give more than a general, and at best incomplete, sketch of the rise and progress of photography in the various lines of astronomical research. To those who have kept pace with these rapid strides in the last twenty years this brief history will seem imperfect, and perhaps of little interest. Many applications of the photographic art and many valuable results have necessarily been omitted. But few of the names of those prominently identified with this subject have been mentioned, and but little of their work even alluded to. A volume of no small dimensions would be necessary to give a complete history of the development of photography in the many directions in which it has been applied to astronomy. The time to do this has not yet come. Progress has been so rapid and far-

reaching that its history, however complete and exhaustive, a year later requires to be re-written; and there is no reason for supposing that the end, or even the beginning of the end, has been reached. With new materials and new methods, and new workers who will profit by the experience and results gained by those who have in our time accomplished so much, we may expect for the new century far greater results than those briefly recorded here.

It would be difficult just here to predict the future of astronomical photography, though one can foresee something of the great results it must accomplish. It will displace some of the visual work, but it is more likely to move along new lines, opening up new fields of research. The older astronomy, so nobly represented by Simon Newcomb and a few others, will be strengthened at every point, and will stand all the more sublime for the help it shall receive from photography.

E. E. BARNARD.

YERKES OBSERVATORY.

THE ZOOLOGICAL SECTION (F) OF THE  
AMERICAN ASSOCIATION FOR THE  
ADVANCEMENT OF SCIENCE.

This section had a successful meeting. Papers of both a general and special nature were presented. The address of Vice-President Alpheus S. Packard, entitled 'A Half-Century of Evolution, with Special Reference to the Effects of Geological Changes on Animal Life,' has appeared in this JOURNAL. A brief outline of the papers read is presented in the following:

*Evolution and Migration of Hawaiian Land Shells.* By PROFESSOR ALPHEUS HYATT.

The author studied about 22,000 shells, of which 18,000 at least were from Oahu. In that island there are about 280 species, as compared with about 140 in all the other

islands of the group. There are three leading genera, *Bulimella*, *Achatinella* and *Apex*. The distribution of the species of these genera was represented on a large relief map of Oahu, by means of colored pins, connected by similarly colored threads. Each pin or series of pins represented a species, as indicated by attached labels.

All the shells probably sprang from a common ancestor, *Achatinella phaeozona* G., which has become extinct in late years. Starting in the valley Kiliouou, as the shells migrated northward, there was an evolution of species and genera as plotted on the map. The principal occurrence of these mollusks is on the western flanks of the eastern range. The *Bulimellæ* inhabit the highest sides of the mountains, crossing to the eastern side, and there evolving a considerable number of species. This genus does not succeed in forming colonies in the range on the western crest of the island. The *Achatinellæ* occupy a lower zone below both the *Bulimellæ* and *Apex*. They cross to the eastern side of the mountains in several places; but are unable to contend successfully with the climate on that side. They were also unable to cross the valley lowlands in the center of the island, except in sporadic cases. The species of *Apex* occupy a middle zone, between the *Bulimellæ* and *Achatinellæ*, on the western flanks of the eastern range. They seem more delicate, and less able to contend with the surroundings on the ocean side of the hills. Not a species has been recorded from that side; but, on the other hand, it crossed the broad plain of the interior, and was successful on the short western range, where only a few sporadic species of the *Achatinellæ* are found. The evidence is that the species are distributed over the island in definite lines, which correspond to definite geographical areas. In the oldest part of the island are the oldest forms as evidenced by development.



*Variation in the Shell of Helix nemoralis, in the Lexington, Va., Colony.* By PROFESSOR JAMES LEWIS HOWE.

THREE series of this introduced snail were collected from gardens. There were over 1,000 shells in each lot. The colony originated in 1883. The conclusions reached from a study of these series are: (1) the variations tend in general along the same lines as in Europe; (2) the tendency of variations differs in different portions of the Lexington colony. The author gave a tabulated list of the varieties known in the Lexington colony, of which the total number was 385. Of these 277 were enumerated for the first time.

*Variation versus Heredity.* By PROFESSOR H. S. WILLIAMS.

VARIATION, and not heredity, is considered the fundamental characteristic of the phenomena of organisms. The arguments for variation versus heredity are as follows:

1. In any concrete case of natural selection, or other similar processes, the actual result of selection is the retarding and checking of variation, and the offspring necessarily evolves more slowly than its parent, in direct proportion to the efficacy of natural selection.

2. That the organic processes by which variation takes place in an organism differ from the ordinary process of development in individual growth only by passing beyond the limit reached by the ancestor, and hence variation is but a phase of the fundamental genetic process peculiar to living organisms.

3. That every act of variation is anterior to experience, and thus is necessarily original and genetic; whereas every hereditary act is necessarily secondary to and the result of experience, and the law of heredity must therefore be acquired in the process of evolution and is not fundamental.

4. That as to struggle for existence the

most strenuous effort made (both by parent and offspring) in the course of organic processes is that which produces antagonism of interests. On the part of the parent it parts with that which has cost it the greatest expenditure of energy, and on the part of the offspring the result is the loss, in part or wholly, of the only source of its living up to the moment of the struggle.

5. That the orthodox view is inconsistent in so far as it recognizes mutability as applicable only to organic species and clings to the idea of the immutability of the more fundamental units of biology, viz., the individual and the cell and the protoplasmic states of matter.

These considerations bring us to a point of view in which heredity and variation hold a different relation to evolution than in the ordinary working hypothesis of biology. If this point of view presents the facts in their true relations we must seek for the immediate determining causes in variation, not in natural selection, nor in any of the environmental conditions, either direct or indirect, by which hereditary repetition is established, but in the phenomena of individual growth and development, and the more fundamental processes of cell growth and metabolism. (To be published in the *American Naturalist*.)

*Localized Stages in Growth.* By DR. ROBERT TRACY JACKSON.

As shown by Hyatt and others, stages in growth occur in the young and old organism, the adult representing full specific characters. The ontogeny of the individual therefore repeats, in an epitomized form, the phylogeny of the group.

From studies of animals and plants it has been found that stages may occur in localized parts throughout the life of the individual. In organisms that during growth present a serial repetition of similar parts there is often an ontogenesis of such parts, which is

more or less closely parallel to the ontogenesis of the organism as a whole, repeating characters seen in similar parts in the young individual and in adults of ancestral types. The repetition is usually of poembryonic or nepionic characters.

In asexual reproduction of Hydrozoa and Actinozoa, buds are given off, which during growth repeat characters seen in later stages of embryos from the egg. Young plates of the stem of certain crinoids throughout life repeat the features of the whole stem of ancestral forms. In ammonites that portion of the complex septum which lies close to the umbilicus is relatively simple, in this localized area repeating youthful and ancestral characters.

In plants, suckers from the roots, or base of stem, or stump, often repeat characters of the seedling, Pitch Pine, Areca, Oaks, Ash, Aralia, Sassafras, Ailanthus. In *Ampelopsis tricuspidata*, at the base, throughout life, the leaves are compound, as in seedlings. On all the remaining old wood, leaves are simple, trilobed (the species character); on wood of the current season's growth, leaves are simple, cordate, like a late stage in growths of seedlings. Degradational localized growth may be reversionary, as tuftlike growths of the Red Cedar, resembling the young and fossil allies. The terminal portion of leaves often repeats the character of leaves of seedlings in a close degree, seen in Tulip tree, Ashes, Ailanthus, Phoenix. Reversionary individual leaves often occur. These have failed to develop full specific characters and bear more or less resemblance to the young and fossil allies, seen in Tulip tree, Ashes, Negundo, Phoenix.

*On the Carboniferous Fauna of Rhode Island.*

By PROFESSOR A. S. PACKARD.

The fauna comprises worms, *Anthracomya arenacea*, crustacean trails, an Arachnid, and 14 species of insects, mostly cockroaches. Comparing with South Joggins, the animal

remains support Lesquereux's reference of the beds (based on the flora) to the upper Carboniferous.

*On the Present State of our Knowledge of the North American Tertiary Mollusk Fauna.* By DR. WM. H. DALL.

REVIEWED fields covered by early workers from Say and Lesueur, in 1822, down to 1860, forming the first period, which was mostly on the coastal plain. A second group, Sowerby, Guppy, Gabb, were occupied with the Oligocene and Pliocene of the Antillean region.

A second period began about 1880. The new workers revised faunal lists, discriminated horizons, correlated continental and Antillean horizons, and discovered new horizons. The most important of these were the Pliocene of Florida, Miocene of Galveston, Texas, and Upper Oligocene of western Florida, as made known by Willcox, Heilprin, Dall, G. D. Harris, Aldrich and others. From recent discoveries, rich faunas have added a multitude of new forms.

*Leidy's Genus Ouramaba.* By WM. L. POEAT.

HE showed that Leidy's view of the filaments as extensions of protoplasm was incorrect. They are mycelial filaments of a fungus, partially parasitic on an Amœba. The filaments arise from the germination of a spore, and issue at once into the water. The structure of the filaments is that of unseptate hyphæ, not of pseudopodia. The genus *Ouramœba* is not valid.

*Moniloporidæ, a New Family of Palæozoic Corals.* By A. W. GRABAU.

*Notes on Æolosoma tenerarum.* By Miss EDITH M. BRACE.

It is shown that the nervous system of this worm, previously considered aberrant, conforms to that of the annelid type. The nervous system is connected throughout with the epidermis. The distribution of nerves and ganglia were described in detail. The sym-

pathetic system and sense organs were described; the latter consist of cells containing a pear-shaped refractive body, also compound bodies similar to the eyes found in other worms.

*A New Classification of Fossil Cephalopods.*

By PROFESSOR ALPHEUS HYATT.

CEPHALOPODS with camerate shells, excluding Belemnoidea, are included in two orders, Nautiloidea and Ammonoidea. The classification of the Nautiloidea is in confusion, owing to the overthrow of the old systems. After revising all the genera and a considerable proportion of the species of this group it was found that the siphuncle offered the best basis for a classification. The siphuncle was of greater importance in ancient than in more recent times, in primitive than in specialized forms, and in the young than in later stages of ontogeny. This assumption is based on the relatively larger size, and more or less complicated structure of this organ, in ancient times, primitive types, and the young of all shells. Proposed sub-orders of Nautiloidea are as follows:

1. Holohoanites, funnels of siphuncle extending across air-chamber, deposits when present, more or less prolonged cones, filling endosiphuncle. Endoceras, Piloceras, Nanno.

2. Mixochoanites, siphuncles small, funnels composite, short in young, collars added in adult. Ascoceras, Aphragmites.

3. Schistochoanites, siphuncles large, funnels imperfect or split on outer side; these are at bases of flat rings or collars. Couoceras, Bronn (Bathmoceras, Barr).

4. Orthochoanites, siphuncles small, except in primitive forms, without deposits, or, if present, irregular and gathered around funnels, no endosiphuncle. Is difficult to separate some forms of this suborder from the Annulosiphonata. Orthoceras, Geisonoceras.

5. Cystochoanites, siphuncles of different sizes, funnels invariably short, bent outwardly. There are two subgroups. (A) Annulosiphonata, siphuncles large in primitive forms, beaded, internal deposits gathered about the funnels. There also are concentric layers advancing toward the interior, large endosiphuncle often present in primitive forms. Actinoceras, Loxoceras. (B) Actinosiphonata, internal deposits arranged as vertical radiating plates, directed toward interior, but not meeting; deposits increase in number of plates and thickness, so they often meet those of next segments. Jovellania, Rizoceras.

*On the Systematic Position of the Trilobites.* By

PROFESSOR A. S. PACKARD.

BEECHER has shown that all segments behind the antennal bear biramous limbs essentially alike for the head and trunk. In Crustacea, on the other hand, there is a differentiation of cephalic appendages. For this reason, with the different larval form, and obvious affinities of trilobites to Limulus which is not a Crustacean, we are inclined to refer trilobites to a separate class, older, more primitive, derived from the annelids on a different line from Crustacea. Probably the merostomes, including Limulus, descended from trilobites or similar forms.

*Measurements of two large Lobsters, recently added to the Collections of the American Museum of Natural History.* By DR. E. O. HOVEY.

Two large lobsters were caught off Atlantic Highlands, N. J., in 1897. Reported weight 31 and 34 pounds respectively. The length as mounted is respectively 92 cm. and 100.5 cm., or over 3 feet in each case.

*A New Method of Studying Underground Insects.* By PROFESSOR JOHN B. SMITH.

SHOWN that plaster of Paris, thinned, made excellent casts of burrows extending



nearly six feet underground, and branched. Satisfactory for burrows of bees, wasps, spiders, many coleopterous larvæ. The better the plaster the better the result. The best dental plaster mixed with an equal bulk of water is satisfactory.

*Notes on the Habits of some Burrowing Bees.*

By PROFESSOR JOHN B. SMITH.

STUDIED by plaster method as referred to above. Several species were studied in Ocean Co., N. J.

*Colletes compacta* appears early in spring, digs almost vertically some 18 inches; then a horizontal burrow is sent off 2-5 inches. At the end a thin parchment-like cell is constructed, in which pollen and honey is stored, and the egg is attached about the middle of the cell. One or two additional lateral tunnels and cells may be built. The entire burrow is filled up, so that the young bees have to bore to the surface.

*Andrena bicolor* and *vicina* make burrows of greater diameter and sinuous, extending 40 inches or more below the surface. General habits of breeding as in *Colletes*. Some smaller species of *Andrena* line their cells with a sticky fluid; the pollen is formed in a loaf, on which the egg is laid.

*Augochlora humeralis* makes a vertical burrow nearly 6 feet deep. It sends off a short lateral burrow, then excavates a chamber 1-2½ inches across; 6-20 cells are constructed from this chamber and lined with clay. Pollen is placed in the form of a loaf, on which egg is laid. Two or three such clusters of cells may be made by one bee, and 30-40 cells may be found in a single cast. When starting the burrow the bee first makes an oblique burrow; after it begins to bore vertically it extends the upward burrow to the surface. The opening is concealed, and no earth is piled there. When the bee is in the burrow the entrance is closed by a ball of sand or clay. The bee does not fill the burrow, so that the

young make an exit through the parent's burrow. They are also used as hibernating quarters. In early spring the females may be found piled on one another at the bottom of burrows.

*On the Markings of Nodontian Larvæ.* By PROFESSOR A. S. PACKARD.

As shown by Eimer and Cope, in the markings of lizards, changes from stripes to spots originate near the tail and extend forward in waves. Weismann has shown the same feature in caterpillars. The author observed the same in several Nodontian larvæ, *Lymmeristia albifrons*, *Dasylophia anguinea*, *Schizura concinna*. In these the longitudinal bands became broken up into spots on the last 4 or 3 segments, where banded arrangement disappears. The explanation is not obvious in lizards; in caterpillars it may be connected with the fact that new segments originate between the last body segment and the penultimate segment.

*The proposed Attempt to introduce Blastophaga psenes into California.* By DR. L. O. HOWARD.

CALIFORNIANS, in their attempt to produce a fig equal to the so-called Smyrna fig, have used cuttings imported from the eastern end of the Mediterranean. It was found that trees dropped the greater part of their fruit. It has long been known by Mediterranean growers that figs are fertilized by the insect *Blastophaga psenes*, which inhabits the wild Caprifig. Branches of Caprifig are collected annually and tied on to the branches of cultivated figs. The insects, loaded with pollen, enter the flowers of the cultivated figs and fertilize them.

In California artificial fertilization has been attempted and has been quite successful, the figs having the flavor of the Smyrna product. This has made it seem probable that if *Blastophaga* could be established in California a fig could be grown quite as

good as those imported. Caprifigs with their insects have been repeatedly imported, but attempts to establish the species have not been very successful. The author recently visited California and found Caprifigs abundant in numerous places. He thinks the time has come to carry on the experiment in a larger way and believes it will be successful.

*Notes on the Life History of Protoparce Carolina.* By PROFESSOR WM. B. ALWOOD.

BREEDING carried on with this species for two years shows that it is slightly double-brooded, at Blacksburg, Va. The earliest moths appear June 7th-12th. Oviposition begins June 20th; larvæ moult 4 times, at intervals of usually 4 days, become full fed in 20-21 days and enter the soil for pupation. A small part of early brood issues as adults the first year; but the greater part are single-brooded and appear as adults in July, after passing the winter as pupæ.

*The Life History of Schizonewra lanigera Hansen.* By PROFESSOR WM. B. ALWOOD.

BREEDING records show that the 'root and stem forms' can be colonized from root to stem, or the reverse, and their natural migrations were observed. Many of the agamic wingless females at Blacksburg, Va., survive the winter exposed on aerial situations. Records show twelve generations of agamic, viviparous females from May 12th to September 20th. At this date winged, agamic, viviparous females were produced in all the colonies observed. These proved a migrant generation and could not be induced to remain at rest on the apple plant under control conditions, but flew away. Under confinement they produced 4-6 young, which were sexed individually. These are small, beakless, with rudimentary lobes where mouth parts should be; about  $\frac{1}{3}$  are males and  $\frac{2}{3}$  females. After copulation females lay one egg, which remains dormant over winter. From

long observations it is concluded that in southern latitudes agamic individuals continue an unbroken chain, and that oviparous reproduction plays no important rôle in the life cycle. Only a small per cent. become winged, but on the contrary continue as normal, agamic, wingless lice.

*The Phylogeny of North American Eucleidæ.*

By DR. HARRISON G. DYAR.

THE Eucleidæ is a family of moths represented by 28-31 species in this country. The author is acquainted with life history of 20 species, and a partial life history of one other has been published. Larvæ offer structural characters of value in classification, and he presented a phylogenetic chart of the 21 species where the young is known. In the first division the lateral tubercle of the first abdominal segment is lost. One branch shows the origin of stinging spines. In another branch the first division corresponds to the loss of the primitive first stage, on the one hand, and to the complete suppression of the many paired warts, on the other. (To be published in *Journal N. Y. Entomological Society.*)

*On the Genitalia in Ants, and their Value in Classification.* By W. H. ASHMEAD.

*The Records for 1898 of Broods VII. and XVII. of Cicada septendecim.* By C. L. MARLATT.

*Remarks on Aphorphora.* By PROFESSOR EDWARD S. MORSE.

*Fossil Butterfly from the Base of the Severn Formation (Cretaceous) of The Potomac River Exposure.* By P. R. UHLER.

*On the Types of Vertebrate Embryos.* By PROFESSOR CHARLES SEDGWICK MINOT.

*On the Embryology of the Rabbit.* By PROFESSOR CHARLES SEDGWICK MINOT.

*Some New Points in Dinichthyid Osteology.* By DR. C. R. EASTMAN.

*Dinichthys pustulosus*, as shown by many characters of the cranial and dorsal shields,

is the most primitive known species of the genus.

In the cranial osteology of *Dinichthys intermedius* the 'parietal' and 'frontal' elements of Newberry and other authors, declared not to exist, the area assigned to them being covered by the centrals, as in *D. pustulosus*, and uniformly throughout the family. Identification of the side plates of the body, heretofore considered missing. The upper or transverse arm of the 'clavicular' is homologous with the anterior lateral of *Coccosteus*, and the inner branch of the bifurcated arm with the interlateral of the same genus. Outer branch of the bifurcated arm has articulated to its distal end a warped plate, supposed to represent a modified branchiostegal apparatus. The term 'clavicular' is thus a misnomer, since the element has nothing to do with a shoulder-girdle, and there is no evidence that such a structure was present in the *Dinichthyids*.

The orientation of the clavicular was described and illustrated by diagrams. The osteology of *Titanichthys agassizii* was also described and illustrated by diagrams.

*Transformation of the Brook Lamprey (Lampetra wilderi), and Parasitism among Lampreys.* By PROFESSOR SIMON HENRY GAGE.

THE transformation of all lampreys is similar, as far as known. The egg develops into a larva comparable to a tadpole, and this transforms into an adult. Up to the present the larvæ of the sea, lake and brook lampreys have not been distinguished. At transformation the sea and lake lampreys are about 150 mm. long, while adults average 700 and 350 mm. respectively. The transformation of the lake lamprey requires 20-30 days until adult form is assumed, but metamorphosis is only begun in this time, and the animal stays under the sand, like a larva, for about 4 months before emerging for a free predatory life.

The brook lamprey attains full size during larval life, and remains under sand some 7 months; it then emerges, builds nest, lays eggs and dies. In the lake lamprey (*Petromyzon marinus unicolor*), from Cayuga Lake, no food, except blood, has been found in the enteron. As the brook lamprey has the same armature of teeth and rasping tongue as lake and sea lampreys it has been considered as also parasitic, but this is a mistake, as shown by experiments in aquaria. The suctorial mouth is used in all lampreys for nest building and mating; the question arises: was the buccal armature developed for this purpose or for a parasitic life?

*Hybernation, Transformation and Growth of the Common Toad (Bufo lentiginosus americanus).*

By PROFESSOR SIMON HENRY GAGE.

IN literature it is stated that the toad hibernates under leaves, logs, etc. From observation it is believed hibernation occurs only in the ground, rather dry and not liable to be frozen. After emerging in spring, if a cold snap occurs, they seek shelter of leaves, etc. In burying itself the toad backs in, the hind legs and caudal end of body being used for digging, and forelegs for pushing backward. No sign of the hole is left.

In a freezing atmosphere the temperature of the toad was  $\frac{3}{4}$  to  $1\frac{1}{4}$  degrees Centigrade higher than surrounding medium. Toads found under frozen leaves were able to crawl. In one case the legs and skin were frozen solid, but not the internal organs; the toad recovered. When frozen solid the toad never recovered.

At Ithaca ovulating extends from the middle of April to the middle of June. Eggs are normally laid in a double string, one from each oviduct; 500-5,000 or more are laid at one time. Eggs hatch in about 4 days. Growth of tadpole is attained in about 40-60 days. After hind legs are well developed



no food is taken and a tadpole changes into a toad within 3 days. We get a clue to activity of life processes in transformation by weighing. A tadpole at maximum size weighed 230 milligrams; after hind legs developed and food was no longer taken, weighed 110 milligrams; two days later, when tail is only 3 mm. long and the little toad has crawled out into air, weight was 70 milligrams; less than  $\frac{1}{3}$  the weight of tadpole from which it developed.

In man and other animals the proportion of water is greater the younger the animal. In a tadpole 91.6% of live weight is due to water; in the just transformed toad 88% is water. The dry weight of a tadpole was 19 milligrams; of a transformed toad, 8 milligrams, less than half the dry weight of the tadpole. There is, therefore, a great loss of substance other than water in transformation of tadpoles into toads. In the growth of the toad there is a steady increase from egg to maximum of tadpole. During transformation there is shrinkage. When the little toad is ready to take food its progress in size is rapid, and in a few years it may be 50,000 times as heavy as the egg from which it came.

*On the Piscine Ancestors of the Amphibians.*  
By PROFESSOR THEO. GILL.

*A Historical Notice on Ross' Rosy Gull, Rhodostethia rosea.* By JOHN MURDOCH.

This species was discovered by Sir James Ross, in 1823, at Alagnak, Melville Peninsula. It was described by Richardson in 1825. Up to 1881 only 14 specimens were known, but from several localities. The Point Barrow expedition (1881-93) found them in large numbers, flying northeast along the shore each autumn, and collected a good series. The delicate pink of the breast after death soon fades on exposure to light. Fifteen additional specimens have since been taken, all from the Arctic region except one (Bering Id.). Nansen found

them abundant in July, near Hvitenland (81° 38' N.). They undoubtedly breed there, but the main breeding ground is probably the land believed to be not far north of Point Barrow. They probably always keep close to the loose edge of the ice-pack. (To be published in full in the *Auk*.)

*The Winter Food of the Chickadee.* By CLARENCE M. WEED.

The paper records a study of the food of the Black-capped Titmouse (*Parus atricapillus*) during winter months. Forty-one specimens were studied from November, 1897, to March, 1898. Results show that this bird feeds on a large variety of insects. The most striking item of food was eggs of aphids, 21 per cent. of the whole. Insects as a class constituted 51 per cent., spiders and their eggs 5 per cent., vegetable matter 28 per cent.; of this 20 per cent. consisted of buds and bud scales, introduced accidentally with aphid eggs; indeterminable 10 per cent.; grit and other extraneous matter 4 per cent. This study yields additional evidence of the usefulness of this familiar bird.

*A Rare Species of Whale.* By PROFESSOR ALPHEUS HYATT.

The specimen came ashore on the beach at Annisquam, Mass., August, 1898. The specimen proves to be a species of *Mesoplodon*, is 12 feet long, measuring along the body. Two teeth, characteristic of the genus, exist in the mid-length of the lower jaw, but are small and not visible above the gum. The only species known in the North Atlantic is *Mesoplodon bidens*; this specimen is probably of that species. This species has been recorded from European coasts, but has been a very rare visitant of our shores.

*Variations in Human Bones.* By DR. THOMAS DWIGHT.

A LECTURE delivered before the Zoolog-

ical (F) and Anthropological (H) Sections. The speaker dwelt especially on anomalous spines of the vertebral column.

*The Fauna of Cold Spring Harbor.* By DR.

C. B. DAVENPORT.

GAVE a general account of this station, a description of which will be published later in this JOURNAL.

*Naples Station: General Description and Notes on Methods of Work Employed There.* By

DR. E. O. HOVEY.

THIS laboratory was established in 1872, by Dr. Anton Dohrn. Although some thirty stations have since been established on similar lines, this has maintained its lead in importance. The most popular feature is the aquarium, which consists of 26 tanks (described in some detail). The chief function is investigation, which is carried on by a corps of nine regular officials, and 30-40 students from all parts of the world. More than 1,000 men have studied at the Laboratory. An important feature is the beautiful preparations of the Naples marine fauna, which are sent to museums and investigators all over the world. The paper presented many interesting and practical details of methods employed.

*General Statement of Types and Figured Specimens of Fossil Invertebrates in the American Museum of Natural History.* By DR. E. O. HOVEY.

THE Museum has at least 8,000 types and figured specimens of fossils. A large part of these are in the James Hall collection, including a large proportion of species of the New York Palæozoic horizons; also important series from Waldron and Spergen Hill, Indiana; Racine, Beloit and other localities in Wisconsin and Minnesota. The Museum has the F. S. Holmes collection, including many Tertiary and Post-Tertiary types from South Carolina; the types of Hall and Meeky from the Cretaceous of Nebraska and many types of species de-

scribed in the Bulletin of the Museum. In the paper a number of other lots of types and figured specimens are mentioned which cannot be referred to in this brief abstract.

*Ink and Paper for Museum Labels.* By DR.

ROBERT T. JACKSON.

DWELT on the importance of carbon writing and rubber stamp inks, as being the only inks suitable for permanent records. Bond or linen record paper advised as being lasting. Ordinary paper not suitable for permanent records. This paper will be published in this JOURNAL.

ROBERT TRACY JACKSON,

*Secretary of Section F.*

#### NOTES ON PHYSICS.

##### SECTION B AT THE BOSTON MEETING.

THE program of Section B contained fifty titles of papers, forty of which were read in full. Many of these papers were of high order and almost every one was creditable and interesting. The increasing activity of Section B and its growing membership are matters for congratulation, and it is probable that an affiliated American Physical Society may soon become desirable and feasible. The proceedings of Section B will be reported in SCIENCE at an early date.

##### THE FLOW OF WATER IN PIPES.

THE flow of water in pipes and channels is again the subject of elaborate investigation,\* but it is doubtful whether anything more than roughly approximate formulation of the laws of flow of water can ever be reached. It seems that the slightest roughness on the inside of a pipe leads to *unstable states* of fluid motion resulting in the formation of eddies. If incipient eddy motion is indeed an unstable state of fluid motion—and our knowledge of vortex sheets, such, for example, as the air jet of an organ pipe, seems to show that it is—then the flow of

\* Paper by G. H. Knibbs, Journal and Proceedings of the Royal Society of New South Wales (XXXI.).

water in anything but a mathematically smooth pipe *cannot be rigorously treated by any of the methods of rational mechanics*, for the very troublesome characteristic of all unstable states of a system is that subsequent aspects of the system are *influenced to a finite extent by infinitesimal initial causes*. The flow of water in a pipe is, in its details, about as difficult to rationalize as the weather.

#### THE SYNCHRONOGRAPH.

PROFESSOR A. C. CREHORE and Lieutenant G. O. Squier have devised means for using individual pulsations of a sinusoidal alternating current for signalling in high-speed telegraphy. Their Synchronograph, as the instrument is called, has been tried by the inventors on some of the lines of the British Post Office, and the results show that the Synchronograph is capable of transmitting words from three to seven times as fast as the Wheatstone apparatus at present in use.

#### SCIENCE ABSTRACTS.

A NEW periodical of the above title is now being published under the direction of the Physical Society of London and of the British Institution of Electrical Engineers. This journal aims to give a complete abstract of current literature in physics and electrical engineering. It certainly has good reason to be, and it will no doubt prove to be of great usefulness to English-speaking physicists and engineers. The abstracting of (foreign) physical papers in the Proceedings of the Physical Society is discontinued.

#### CATHODE RAYS.

SIR WM. CROOKES' original hypothesis that cathode rays consist of rapidly-moving, negatively-charged particles is proving to be increasingly useful in leading to and interpreting new experiments. Lenard\* has recently measured the variations of velocity of cathode rays, which are produced when the rays pass parallel to the lines of force

in an electrostatic field—a field independent from that which produces the rays. These measurements were made by observing the deflection of the rays by a magnetic field. The velocity of the cathode rays, calculated from the observed deflection, ranges from  $\frac{1}{10}$  to  $\frac{1}{3}$  of the velocity of light. These variations of velocity were also clearly indicated by observed variations of the deflection produced when the altered cathode rays were passed at right angles to an auxiliary electrical field, though the author did not calculate the various velocities in this case from the observed electrostatic deflections.

Merritt\* has shown that cathode rays reflected from a platinum obstacle have the same velocity as the incident rays—that is, to say the reflected and incident rays are equally deflected by a magnetic field. If the moving particles in the cathode rays are about  $\frac{1}{1000}$  as massive as hydrogen molecules, as has been pointed out by J. J. Thomson, then these particles should show but little diminution of velocity after impact with platinum molecules, and corresponding to this the reflected and incident rays should be equally deflected by a magnetic field.

#### THE ELECTROCHEMICAL EQUIVALENT OF SILVER vs. THE MECHANICAL EQUIVALENT OF HEAT.

ROWLAND'S value of the mechanical equivalent of heat, reduced by W. S. Day† to the Paris hydrogen temperature scale, is distinctly different from the value of this equivalent as determined electrically by Griffiths and by Schuster and Gannon. The electrical method involves the electrochemical equivalent of silver, inasmuch as the measurement of current was carried out in these experiments by means of the silver voltameter. A redetermination of the

\* Paper read before Section B at Boston.

† *Physical Review*, VII., 193.

\* Wied. Ann., Vol. 65, p. 504.



electrochemical equivalent of silver by Patterson and Guthe,\* under a grant from the American Association, brings Griffiths' value for the mechanical equivalent of heat into coincidence with Rowland's value. This work of Patterson and Guthe is of the greatest importance and is greatly to the credit of the American Association Committee on Standards of Measurement.

W. S. F.

#### CURRENT NOTES ON METEOROLOGY.

##### PAPAGUERIA.

SINGULARLY emphatic is the control exercised by the climatic conditions in the arid region of southern Arizona over the animal and vegetable life that is found there, as is shown by McGee in a recent article on 'Papagueria' (*National Geographic Magazine*, August). The district inhabited by the Papago Indians, south of the Gila river and southwest of the Sierra Madre and bounded on the southwest by the Gulf of California, is extremely arid. The scanty vegetation is fitted for its peculiarly difficult struggle for existence by being pulpy in structure and having impervious rinds for preserving moisture, as well as by being provided with thorns. The animals are armed with mandibles, stings, poison glands and other protective devices. In order to carry on the struggle for existence as successfully as possible, animal and vegetable life associates itself in communities, where grasses, trees, cacti, insects, reptiles, birds and mammals live together in harmony and mutual coöperation. The most interesting control of the climate is naturally that over man. The keynote to the understanding of the life and habits of the Papago Indians is to be found in the climatic conditions. The semi-nomadic life of the greater portion of the tribe; the building of their rude huts in the vicinity of permanent or temporary

springs; the absolute dependence of the times of planting and of harvesting upon the storms or freshets; the migrations southward and northward with the coming on of summer or winter—in these and in many other ways climate is seen to be the great control in the life of the people. As the writer strongly emphasizes at the conclusion of his extremely interesting paper, "the life of the Papago is a round of migrations and wanderings, largely in search of the means of subsistence, of which the first and the second and the third are water, *water*, WATER—water to alleviate his own thirst in the sun-parched deserts, water to sustain his horses and burros and kine, water to vivify the plants of which man and his creatures eat."

##### TREE PLANTING ON THE PLAINS.

A NUMBER of points of meteorological interest are found in Bulletin No. 18 of the Division of Forestry, entitled 'Experimental Tree Planting in the Plains,' by Charles A. Keffer, Assistant Chief of the Division. The experimental tree plantings described in this report were begun in 1896, in South Dakota, Nebraska, Kansas, Colorado, Minnesota and Utah. Protection, then amelioration of climate, is the principal object of the plantings, a wood supply being a secondary consideration, for the growing of timber on a commercial scale on the Plains is hardly to be expected. That a lack of sufficient moisture is the cause of the treelessness of the Plains has often been claimed, but many artificial plantings are now growing successfully in what was a few years ago a treeless region. A study of the climatic and soil conditions, and the results of the experiments, lead to the conclusion that the line of successful tree culture will move westward as the agricultural development of the country goes on, and as the soil is more and more broken up and disintegrated. The preva-

\*Reported to Section B at the Boston Meeting.

lence of winds in the region of the Plains is hostile to agriculture, by reason of the increased transpiration from vegetation and the evaporation from the soil thereby produced; and trees planted in masses or large groves, in selected locations, form excellent wind-breaks and protect the crops for some distance to leeward of them. The Bulletin contains full descriptions of the various experimental plantings and is well illustrated.

R. DEC. WARD.

HARVARD UNIVERSITY.

---

*BACTERIOLOGICAL NOTES.*

THE bearing of optical aids upon the growth of our knowledge of disease-producing germs is well illustrated by two contributions recently made to the Ninth International Congress of Hygiene and Demography, held at Madrid. The work of Loeffler and Frosch on the ætiology of foot and mouth disease in cattle was reported. The disease-germ of this disease is so small that it passes, contained within the lymph, through Berkefeld filters that hold back the smallest known microorganisms. This germ is thus far known by its effects only, for the highest power of the microscope fails to disclose anything in the filtered lymph, which is yet capable of setting up the disease upon inoculation. That the disease does not depend upon some soluble toxic agent contained within the lymph is proved by the fact that the disease has been transmitted through a series of six animals, the original material, which was employed for the first inoculation, having been obtained from a case of the natural disease. In each successive inoculation the lymph was filtered. We know of no toxic substance so potent, nor, indeed, is it probable that anything but a living and multiplying organism could be so active as to be transmissible through such a number of cattle, each one of which succumbs in turn to the

disease produced. These authors do not even conjecture as to the probable character of the microorganism concerned.

The microorganism of infectious pleuropneumonia of cattle has also been sought by many bacteriologists. It has just been obtained by Nocard and Roux. The lymph taken from the affected lungs is highly infectious and readily produces the disease in cattle upon inoculation. Cultures made with this material had always remained sterile, and most painstaking search had failed to reveal any foreign elements in the lymph. By a novel procedure, first introduced by Metschnikoff, Nocard and Roux succeeded in obtaining cultures of the microorganism. If small sacs (or bladders) made of celloidin are filled with sterile bouillon and placed in the peritoneal cavity of the rabbit they undergo no change, the fluid remains clear and limpid, and the animal is unaffected. If, however, a minute quantity of the lymph from an infected lung is introduced into the sac, after a period the bouillon becomes opalescent. Transplantation from one sac to another brings about similar results. Microscopical examination of the turbid fluid shows an entire absence of wandering or other body cells, but a magnification of 1,600 to 1,800 times brings to light very minute round or elongated bodies which are believed to be the parasites of the disease. After the sacs have remained for a time in the abdominal cavity of the rabbit these animals lose weight and become cachectic. Albumen probably diffuses into the sacs and toxic substances into the peritoneal cavity. These cultures are exceedingly active and produce the typical disease upon inoculation. At first all attempts to cultivate this minute organism outside the body failed, but later through the use of a special culture medium success was achieved.

It is safe to assume that the parasite of foot and mouth disease is much smaller

than that of pleuro-pneumonia, as the latter does not pass through filters designed to exclude ordinary bacteria. And it is also highly probable that a further refinement of the microscope will bring to light not only the organism of foot and mouth disease, but probably many more infinitesimally small living forms.

SIMON FLEXNER.

#### CURRENT NOTES ON ANTHROPOLOGY.

##### THE FOLK-SONG SOCIETY.

As a branch of the study of folk-lore, what may be called folk-songs, *Volkspoesie*, has long held a prominent place. Ten years ago Dr. Krejci wrote: "Die Volkspoesie ist der eigenste Ausdruck der Volksindividualität." The time was quite ripe, therefore, when this summer in London the first meeting was held of the 'Folk Song Society,' under the presidency of Lord Herschell. Its aim is to discover, collect and publish folk-songs, ballads and tunes. Meetings will be held from time to time and collections will be published.

The subscription is 10s. 6d. annually, and those who wish to become members should address the Honorary Secretary, Mrs. Lee, 41 Rosary Gardens, London, S. W.

##### ARTICLES ON WAMPUM.

In the *American Antiquarian* for February there is an article by the Rev. W. M. Beauchamp on 'Wampum Used in Council and as Currency.' He collects a number of examples of both uses from early writers, but acknowledges that "very few shell beads of any kind are met with on the earlier sites of the Huron-Iroquois."

This fact accentuates a historic doubt I have expressed in the *Bulletin* of the Museum of the University of Pennsylvania (May, 1898) that wampum belts were made by the pre-historic Indians. All known to me are later than the discovery and none have been found in ancient burials. Even

the form of bead seen on the belts does not occur in pre-Columbian interments (Holmes).

##### NATIVE FACE-PAINTING.

PAINTING the face is probably the oldest of the fine arts, at least the learned Dr. Hoernes says so in his last book. That it is not yet extinct we all know. How it is carried on among the Indians of British Columbia is the subject of a handsome monograph written by Dr. Franz Boas and published by the American Museum of Natural History, June, 1898. He explains the complex designs adopted and the symbolism they convey, and adds nearly a hundred illustrations drawn from life. The general artistic principle of the native artist is to force the form into the decorative field in such a way as to bring into view its important parts, at no matter what sacrifice of perspective and natural relations. Conventionalism is carried to the extreme, and it often exercises the ingenuity of the observer to make out what subject is represented.

D. G. BRINTON.

UNIVERSITY OF PENNSYLVANIA.

##### SCIENTIFIC NOTES AND NEWS.

THERE were about 200 members in attendance at the Fourth International Congress of Physiologists, which met at Cambridge from the 23d to 26th of August. A number of important papers were contributed, of which we may be able to give some account in a future issue. The Fifth Congress will be held by invitation of Professor Mosso at the University of Turin in the latter part of September, 1901.

AT the closing meeting of the International Congress of Zoology a committee was appointed, consisting of Professor Schulze, Professor Pelseneer, Mr. A. H. Evans and Professor Mark, to report on the practicability of uniformity in abbreviations and other questions of terminology.

AN international congress on maritime fisheries was opened at Dieppe on September 2d.



There were 300 members present, Great Britain, France, the United States, Russia, Italy, Norway, Denmark, Spain, Belgium, Japan and Venezuela being represented.

DR. HUBERT LUDWIG, professor of zoology at Bonn, and Dr. G. Haberlandt, professor of botany in the University of Graz, have been elected corresponding members of the Berlin Academy of Sciences.

PROFESSOR VOLKENS has been appointed one of the custodians of the Botanical Gardens at Berlin.

PROFESSOR KOCH, who, as we have already reported, is now in Italy studying malaria, has been given a dinner by men of science at Rome, presided over by Professor Baccelli.

DR. D. MORRIS, lately Assistant Director of the Royal Gardens at Kew, takes up, from the 1st inst., the position of Commissioner of Agriculture for the West Indies, to which he was appointed some time ago. He will preside over the new botanical department which has been constituted as a charge on the Imperial fund in accordance with the recommendation of the West Indian Royal Commission and the recent vote of the House of Commons. He left for Barbados on the 21st inst.

SIR WILLIAM MARTIN CONWAY has made the ascent of Mount Illimani, one of the loftiest peaks of the Bolivian Andes, about twenty-five miles east of La Paz. The mountain is 22,506 feet high, and the ascent occupied five days.

MR. C. F. BAKER, Assistant Zoologist in the Alabama Agricultural Experiment Station, has been given leave of absence for eighteen months, beginning January 1, 1899, to visit South America on a collecting expedition.

DR. ROBERT ZIMMERMANN, formerly professor of philosophy at Vienna, died on September 1st at Salzburg, in his 74th year. He had made important contributions to æsthetics and other departments of philosophy, being regarded as one of the leaders of the Herbartian school.

DR. DIETRICH NASSE, associate professor of surgery at Berlin, was killed by an Alpine accident in the Upper Engadine at about the 1st of September. Only two weeks ago we were compelled to record the death of Professor Hop-

kinson by a similar accident. Remembering the deaths of Francis Balfour, of Milnes Marshall and of other scientific men we have a heavy account against the Alps.

AT the recent Syracuse meeting of the American Microscopical Society officers were elected as follows: President, Dr. William C. Krauss, of Buffalo; First Vice-President, Professor A. M. Bleile, of Columbus, O.; Second Vice-President, Dr. G. C. Huber, of Ann Arbor, Mich.; Secretary, Professor Henry D. Ward, of Lincoln, Neb.; Treasurer, Magnus Pflaum, of Pittsburg; Executive Committee, Professor S. H. Gage, of Ithaca; Dr. A. Clifford Mercer, of Syracuse, and Dr. V. A. Moore, of Ithaca.

DR. W. H. WILEY, Secretary of the Association of Official Agricultural Chemists, has sent out a notice stating that, in harmony with the vote of the Executive Committee, the date of the fifteenth annual meeting of the Association has been fixed for November 11th. The sessions will be held in the lecture hall of the Columbian University, Washington, beginning at 10 a. m., Friday, November 11th, and continuing Saturday and Monday, or until the business of the Association is completed. These dates immediately precede the meetings of the Association of Agricultural Colleges and Experiment Stations, which will convene in Washington, November 15th. The order of business agreed upon by the Executive Committee is as follows: Report on nitrogen; on potash; on phosphoric acid; on soils and ash; on foods and feed stuffs; on food adulteration; on dairy products; on sugars; on tannin; reports of special committees.

THE geographical societies of twenty-five towns of France and French Africa are sending delegates to the nineteenth session of the National Congress of French Geographical Societies, which meets at Marseilles from the 19th to the 25th of September. Prince d'Alenbergh is President of the Congress.

ARRANGEMENTS have been made by the authorities of Georgetown University, Washington, D. C., for a course of six illustrated popular lectures, open both to students and to citizens of Washington. The subjects are as follows:

October 12. Household Insects, L. O. Howard, Ph.D.

October 10. Marine Life, James E. Benedict, Ph.D.

October 26. Biology of the College Walks, Sylvester D. Judd, Ph.D.

November 2. Jack Rabbit. T. S. Palmer, M.D.

November 9. German-American Pork Question. Ch. Wardell Stiles, Ph.D.

November 16. Geographical Distribution of Animals and Plants, C. Hart Merriam, M.D.

THE seriousness of the recrudescence of the plague seems to be scarcely appreciated, if we may judge from the comparative silence of the daily papers. Since August 6th the number of cases in Bombay and throughout the Presidency has greatly increased, no fewer than 2,300 deaths having occurred in the Presidency during the last week regarding which news is at hand. Plague is also epidemic in the Madras Presidency and occasional cases occur in Calcutta.

MOUNT VESUVIUS is in eruption more actively than at any time since 1872. The central crater and some seven new outlets are throwing out lava and ashes. Imposing streams are flowing down the mountain sides, burning the chestnut woods at the base of Monte Somma, nearly reaching the Observatory, and destroying part of the railroad. Professor Tasconi, the Director of the Observatory, does not expect, however, that any serious damage will be done.

The daily papers have published full details of the destructive hurricane which on the night of September 11th swept over the Windward Islands and proved especially destructive at St. Vincent and Barbados. The Weather Bureau furnishes the following statement: "The hurricane which created such destruction in the West Indies on Sunday night was detected at its inception on Saturday by the new West Indian hurricane service of the Weather Bureau of the Department of Agriculture. At 8 a. m. on Saturday morning observations on the islands of Martinique and Trinidad gave slight indications of a disturbance southeast of the Windward Islands. At 12:40 p. m. a special observation at Barbados indicated a fall of nearly  $\frac{1}{10}$  in the barometer during the preceding two hours. This movement of the barom-

eter at Barbados, taken in connection with the whole atmospheric survey made four hours previously, satisfied the forecast officer that the hurricane would soon develop over the Windward Islands, although to the non-expert there were no indications of a coming storm. Hurricane warnings were immediately despatched to all ports in the islands of Barbados, Martinique, St. Kitts and St. Thomas, and they were advised to prepare for a destructive storm. Cable communication was perfect and the warnings were promptly received. They were informed that the hurricane would move from a point south of Barbados, and that it would travel slowly northwesterly, with wind increasing to a hurricane velocity. Advisory messages were sent to Colon, Curaçoa, San Domingo, Trinidad and Santiago. A message was also sent to Admiral Watson's fleet, lying in the harbor of Caimanera, Cuba. How completely these warnings were verified by the coming of the storm twenty-four hours later is shown by the press despatches of this morning. While the destruction of life and property has been great, there is no question but that hundreds, if not thousands, of lives and millions of property were protected by the complete warnings given by the United States. These warnings were of profit to the commerce of all nations. Without considering the saving in human life, they have, from a commercial standpoint, fully justified the President in asking for the necessary appropriation, and in personally conducting the inauguration of a complete and efficient meteorological service."

THE *Electric World* quotes from the London *Electrician* an application of wireless telegraphy at a recent regatta, when Signor Marconi demonstrated the adaptability of his system to the transmission of press intelligence from a steam launch in motion. The yachting expert on deck dictated his account of the races while these were in progress, and a stream of dictated 'copy' descended below deck to Signor Marconi, who sat in a cabin working his transmitter, whence the ether waves carried the news with a minimum loss of time to a fixed receiving station on shore. Arrived at this point, the news was forwarded to the press offices by telephone. It is stated that one edition

of the local *Evening Mail* contained two whole columns of news dispatched entirely by wireless telegraphy. The notable event is undoubtedly the germ of an important development of wireless telegraphy in the near future.

THE Duke of Abruzzi is about to issue a book describing his recent ascent of Mount St. Elias. The author's and illustrators' profit upon it are to be devoted to a fund for assisting needy Italian guides.

#### UNIVERSITY AND EDUCATIONAL NEWS.

It was announced last spring that \$500,000 had been given to the Medical College formed by the professors resigning from the Medical School of New York University and annexed to Cornell University. The gift was at the time made anonymously, but was supposed to be from Colonel Oliver H. Payne, one of those who resigned from the Council of the University after the difficulties. It is now definitely announced that Colonel Payne is the donor and that the gift to the Cornell University Medical College amounts to \$1,500,000. Plans for a building to cost \$500,000 are being made by McKim, Mead & White, the architects, and work on the structure is to be begun within thirty days. The plot of land which has been purchased is the entire block on the west side of First Avenue, between Twenty-seventh and Twenty-eighth Streets. It is expected that the new building will be ready for occupancy by October, 1899.

THE late Rowland Hazard, of Peacedale, R. I., has bequeathed \$100,000 to Brown University. This sum is not to be paid for three years, and if the estate should depreciate in value the executors are empowered to reduce the amount to not less than \$50,000.

MR. GEORGE A. GARDNER has given \$20,000 to the Massachusetts Institute of Technology, to be added to the general endowment fund.

DR. D. K. PEARSONS, of Chicago, has offered \$50,000 to Fairmount College, Wichita, Kans., on condition that \$150,000 can be raised.

MR. H. J. PATTERSON has been elected Director of the Maryland Agricultural Experiment Station, *vice* R. H. Miller, resigned. The State

Legislature has appropriated \$14,000 for the erection of a Science Hall, to be used jointly by the College and Station. It has also appropriated \$10,000 for inaugurating State work in entomology and vegetable pathology, and has provided for an annual appropriation hereafter of \$8,000 for its maintenance. C. O. Townsend has been elected Botanist and Pathologist in the College and Station and State Pathologist.

PRESIDENT KELLOGG, of the University of California, has resigned.

MR. J. M. POOR has been appointed instructor in astronomy in Dartmouth College, but we understand that Professor E. B. Frost, now of the Yerkes Observatory, will have supervision of the department and will spend part of the year at Hanover. Dr. G. H. Gerold, of the Dartmouth Zoological Department, has been given a year's leave of absence to be spent abroad, and Dr. H. S. Jennings, last year instructor in the University of Montana, will temporarily take Dr. Gerold's place. Other appointments at Dartmouth are: Dr. C. H. Richardson, to be assistant in chemistry and instructor in geology, and Mr. J. B. Proctor, to be assistant in mathematics.

DR. E. EMMET REID, of Johns Hopkins University, has been elected professor of chemistry and physics in the College of Charleston, S. C.

DR. O. BREFELD, professor of botany at the Münster Academy, has been called to the University of Breslau.

#### DISCUSSION AND CORRESPONDENCE.

##### AN UNUSUAL AURORA.

LAST evening (September 11th) I witnessed at this place what I suppose to be an aurora, and which, if such, showed features so unusual as to seem worthy of record. The air was remarkably clear for the climate of this region and no perceptible wind was blowing. At 7<sup>h</sup>50<sup>m</sup> E. S. T. I walked out to a good point of view, free from artificial lights, to look for the zodiacal light and the 'Gegenschein.' I soon noticed in the south what I supposed at first to be a white cloud, which, however, soon disappeared. Later the supposed cloud repeatedly



reappeared and disappeared in so unusual a way that I watched it more closely. It was oval in form, the longer axis parallel to the horizon, bright in the central part and fading out gradually at the border. It filled the comparatively vacant space to the east of  $\alpha$  Capricorni, and was perhaps five or six degrees in length. After some time I satisfied myself that it could not be a cloud from the facts that it did not obscure the stars, one or two of which were on its boundary; that it was, at brightest, twice as bright as the Milky Way; that it brightened up and disappeared again too rapidly, and was apparently almost fixed in position. In the latter feature and in its regularity of outline it also differed from any aurora I have ever seen. Toward the close of the exhibition it moved a little to the west, so that its last appearance was nearly central over  $\alpha$  Capricorni. It last showed itself about 8<sup>h</sup>30<sup>m</sup>. It must, therefore, have lasted in all at least 40 minutes, during which time it brightened up and nearly or quite disappeared again perhaps ten or twenty times. A noteworthy feature was that there was nothing like an auroral streamer and no aurora elsewhere, unless an extremely faint, fixed illumination of the sky along the north horizon was such.

Quite likely it was an auroral beam seen end on. If so, it affords one of the best opportunities that have ever occurred to determine the height and length of such a beam. I, therefore, describe the phenomenon in the hope that it may have been seen and its position noted in other parts of the country.

SIMON NEWCOMB.

HARPER'S FERRY, W. VA.,  
September 12, 1898.

#### SCIENTIFIC LITERATURE.

*Essays on Museums and Other Subjects Connected with Natural History.* By SIR WILLIAM HENRY FLOWER, K. C. B. London, Macmillan & Co., Limited; New York, The Macmillan Company. 1898. Pp. xv + 394.

Although the *Essays on Museums* form but a quarter of the bulk of this volume, they not unnaturally are accorded the first place on the title-page and form the opening chapters of the book. As Director in turn of the Museum of

the Royal College of Surgeons and of the British Museum of Natural History, Sir William Flower has had an acquaintance with museums accorded to few, while his words have an additional value from the fact that he was practically the first to recognize the duties of a museum to the public and the important educational rôle it should be made to play. As he says: "The idea that the maintenance of a museum was a portion of the public duty of the State, or of any municipal institution, had, however, nowhere entered the mind of man at the beginning of the last century." And he might have added that there are some who still think the principal, if not the sole, object of museums should be the accumulation of material for the use of private individuals.

In this connection it is somewhat surprising to find the late Dr. J. E. Gray quoted as stating that the purposes of a museum are two: "first, the diffusion of instruction and rational amusement among the mass of the people; and, secondly, to afford the scientific student every possible means of examining and studying the specimens of which the museum consists."

"The first consideration in establishing a museum, large or small," says Professor Flower, "is that it should have some definite object or purpose to fulfil; and the next is that means should be forthcoming not only to establish, but also to maintain the museum in a suitable manner to fulfil that purpose. Some persons are enthusiastic enough to think that a museum is in itself so good an object that they have only to provide a building and cases and a certain number of specimens, no matter exactly what, to fill them, and then the thing is done; whereas the truth is the work has only then begun. What a museum really depends on is not its building, not its cases, not even its specimens, but its curator." And great stress is laid upon the fact that the care and administration of a museum, and its efficiency as an educational factor in a community, demands not only especial knowledge and training, but an inborn fitness for the work, and that these in turn are worthy of their due remuneration. In addition to skill, education, manual dexterity and good taste the museum curator should possess various moral qualifications not found in every professional man—punctuality, habits of

business, conciliatory manners, and, above all, indomitable and conscientious industry in the discharge of the small and somewhat monotonous routine duties which constitute so large a part of a curator's life." No one not familiar with the requirements of a large public museum could have put the case so graphically, nor would he have added: "Such being the requirements of the profession, what are the inducements offered to me to take it up as a means of livelihood?" And in answer to this Sir William quotes some examples of the 'inducements' offered, which in many cases are small enough, and to us, on this side of the water, where museum work is beginning to be better appreciated, even pitifully small. And, again, we read that "museums do not grow of themselves; money, time, knowledge and loving and sympathetic care must be expended upon them," and that "a museum must have an endowment adequate to defray its expenses and especially to ensure the staff of intelligent, educated and paid curators required to maintain it in a state of efficiency." All of which comes with unusual force from one who had drawn one of the few great prizes in museums, but who nevertheless realized the general inadequacy of museum salaries.

As regards the exhibition part of a museum the ground is well taken that the number of objects should be limited, but that every care should be taken in their selection, preparation and installation, and a plea is entered for the 'sadly-neglected art of taxidermy.' While it is to be borne in mind that this plea was made nearly ten years ago, it is a plea that will stand reiteration for some time to come. The advocacy of the concentration of type specimens in large museums will commend itself to all workers, for while it may sound well to have it said that this and that institution possesses such and such types the student can well appreciate the boon of having them concentrated.

Local, School and Boys' Museums are each the subject of an essay, and each contains many valuable ideas, while the concluding paper of the museum series, though first in point of time, is devoted to the history of the Museum of the Royal College of Surgeons. The evolution of this great institution from the collections left

by John Hunter is described at length, and while the museum owes its existence to the untiring zeal and industry of Hunter, yet we learn that in housing, caring for and adding to the Hunterian collection the College of Surgeons has expended over \$2,000,000.

In connection with the papers on museums Professor Flower pays tribute to the memory of Dr. G. Brown Goode, whose energy and devotion have done so much to advance the standards of museum methods in the United States.

Among the essays on subjects other than museums that on 'The Paleontological Evidence of Gradual Modification of Animal Forms' may still be read with profit, notwithstanding that since it was written, some twenty-five years ago, there has been a great accumulation of facts, especially through the labors of American paleontologists.

'Fashion in Deformity' will probably lead in favor among the anthropological papers, although all are interesting and instructive reading.

'Whales and Whale Fisheries,' the most recent of all, is a most admirable *résumé* of the subject; and the history of the southern whale fishery, now being repeated in the Arctic, shows well that no animal is too large nor its pursuit too difficult to prevent its extermination if only there is a little money in it.

While we can but regret the loss to science through the enforced period of restraint from active occupation noted in the opening lines of the preface, yet the bringing together and issuing of this volume of essays is at least some small compensation to the public.

F. A. L.

#### NEW BOOKS.

*Infinitesimal Analysis: Vol. I. Elementary: Real Variables.* WILLIAM BENJAMIN SMITH. New York and London, The Macmillan Company. 1898. Pp. xv + 352. \$3.25.

*The Groundwork of Science: A Study in Epistemology.* ST. GEORGE MIVART. New York, G. P. Putnam's Sons; London, Bliss, Sands & Co. 1898. Pp. xviii + 328.

*Die Chemie im täglichen Leben.* LASSAR-COHN. Hamburg und Leipzig, Leopold Voss. 1898. 3d Edition. Pp. vii + 317.

# SCIENCE

EDITORIAL COMMITTEE: S. NEWCOMB, Mathematics; R. S. WOODWARD, Mechanics; E. C. PICKERING, Astronomy; T. C. MENDENHALL, Physics; R. H. THURSTON, Engineering; IRA REMSEN, Chemistry; J. LE CONTE, Geology; W. M. DAVIS, Physiography; O. C. MARSH, Paleontology; W. K. BROOKS, C. HART MERRIAM, Zoology; S. H. SCUDDER, Entomology; C. E. BESSEY, N. L. BRITTON, Botany; HENRY F. OSBORN, General Biology; C. S. MINOT, Embryology, Histology; H. P. BOWDITCH, Physiology; J. S. BILLINGS, Hygiene; J. MCKEEN CATTELL, Psychology; DANIEL G. BRINTON, J. W. POWELL, Anthropology.

FRIDAY, SEPTEMBER 30, 1898.

## CONTENTS:

<i>The Electric Current in Organic Chemistry</i> : PROFESSOR EDGAR F. SMITH.....	413
<i>The Conception of Species as Affected by Recent Investigations on Fungi</i> : PROFESSOR W. G. FARLOW.....	423
<i>The British Association for the Advancement of Science</i> .....	436
<i>Notes on Inorganic Chemistry</i> : J. L. H.....	439
<i>Current Notes on Anthropology</i> :— <i>The Trenton Ice Man; Ancient Mexican Migrations; The Color of the American Indian</i> : PROFESSOR D. G. BRINTON.....	440
<i>Scientific Notes and News</i> .....	441
<i>University and Educational News</i> .....	446
<i>Scientific Literature</i> :— <i>Nature Study in Elementary Schools</i> : WILBUR S. JACKMAN.....	446
<i>New Books</i> .....	448

MSS. intended for publication and books, etc., intended for review should be sent to the responsible editor, Professor J. McKeen Cattell, Garrison-ou-Hudson, N. Y.

## THE ELECTRIC CURRENT IN ORGANIC CHEMISTRY.\*

It is now almost a century since Volta, the Italian physicist, wrote the following words:

“I have made experiments, showing the transmission of the electric fluid. \* \* \* I

\*Address of the Vice-President before Section C—Chemistry—of the American Association for the Advancement of Science, August, 1898.

have applied different metals to all sorts of animal bodies \* \* \* even to such substances as paper, leather, linen (well saturated with water), as well as to water itself. \* \* \* The metals are not only conductors of electricity, but they also excite it, and this is a grand discovery!”

Yes, it was, indeed, a ‘grand discovery,’ for it led to further investigation with the final demonstration that animal and metal electricity were identical. What is more, it unquestionably opened the way to the construction of the battery bearing the name of this honored investigator, who, however, little dreamed of the splendid achievements which were to follow the introduction into chemistry of the form of energy made so readily accessible by his battery and its numerous subsequent modifications. For history tells us that he failed to observe the decomposition which arose upon immersing the terminals of one of his cells into water. That was to remain for the keener vision of Nicholson and Carlisle. The chemical phenomena, exhibiting themselves constantly to Volta while experimenting with his battery, were to him absolutely devoid of interest, yet they continued to crowd to the front and eventually attracted the attention of a brilliant coterie of investigators, whose discoveries could never have come in their most shadowy forms to Volta in his wildest dreams! In evidence of this I need merely mention the



electrolytic decomposition of water, just alluded to, by Nicholson and Carlisle; the deposition of the metals lead and silver (probably the beginning of electro-chemical analysis); the remarkably mysterious and quiet passage of oxygen from the end of the silver terminal over to the zinc terminal, where it appeared as gas—all observed by Cruikshank; the discovery by Davy that the current set free hydrogen and oxygen from water in the proportion in which they united to form the parent substance; the conclusion reached by Ritter that reduction invariably took place at one pole while oxidation occurred at the other; the evolution of Grothuss' theory in regard to the decomposition of liquids generally by the current—a theory highly suggestive in various directions. Thus, the esterification theory of Williamson is based upon the same idea of alternate decompositions and re-formations; the magnificent conquests made by Davy, culminating in the isolation of the interesting and valuable alkali metals, sodium and potassium; giving to the chemical world not only two new elements, but also inciting students the world over to research in wide-reaching fields—a discovery pronounced by Ostwald to be 'the close of the first act of the electro-chemical drama,' and yet what wonderful progress had been made through the application of the new agent. But richer discoveries were to follow. Recall the labors of Berzelius and Hisinger, upon which was founded a theory now almost forgotten, and in its day a retarder, in some measure, of the proper understanding of simple chemical combinations. But it was helpful and contributed at least a mass of facts, applied later successfully in the solution of various chemical problems. And as we advance I must not fail to mention Becquerel, de la Rive and Pfaff, who contributed much of lasting value during the controversy waged by the adherents of opposing schools in regard to

the origin of the current, in the midst of whom appeared the immortal Faraday, fixing the relation between the electrical magnitudes and the combining numbers of chemistry, really taking the initial steps in the foundation of the quantitative period of electro-chemistry. I must not, however, dwell too long upon the many observations made by him. Let suffice the mere mention of his identification of machine and Volta electricity; his declaration concerning electro-chemical decomposition that 'the effect is produced by an internal corpuscular action, exerted according to the direction of the electric current, and that it is due to a force either superadded to or giving direction to the ordinary chemical affinity of the bodies present;' his suggestion, after wrestling with the nomenclature of that day prevalent in electro-chemistry, of the terms anode, kathode, electrode, ion, etc.; his efforts to measure electricity when he wrote 'that the decomposing action of the current is constant for a constant quantity of electricity,' and following this thought constructed an instrument which, 'being interposed in the course of the current used in any particular experiment, should serve at pleasure either as a comparative standard of effect or as a positive measurer of this subtle agent.' Again, having repeated all his earlier experiments with the most varying conditions, he wrote 'variations in the intensity \* \* \* produced no difference as to the equal action of large and small electrodes;' and when he had completed his volta-electrometers they were so arranged that "after the current had passed through one it should divide into two parts; these after traversing each one of the remaining instruments should re-unite. The sum of decomposition in the latter two vessels was always equal to the decomposition in the former vessel \* \* \* exactly the same quantity of water was decomposed in all the solutions by the same quantity of elec-

tricity." When the current acted upon caustic soda or potash, magnesium sulphate or sodium sulphate, just as much hydrogen and oxygen were evolved from them as from the diluted sulphuric acid with which they had been compared. And his final declaration in regard to water 'that when subjected to the influence of the electric current a quantity of it is decomposed exactly proportional to the quantity of electricity which had passed.' Nor can I refrain from a brief allusion to the electrolysis of molten salts, also conducted by Faraday. You all remember the experiment he performed with lead chloride. The weighed platinum-wire kathode was introduced into the molten salt; 'a button of alloy could be observed gradually forming and increasing in size.' In time the experiment was interrupted, when it was discovered that the 'positive electrode had lost just as much lead as the negative had gained \* \* \* the equivalent number, by comparison with the result in the volta-electrometer, being 103.5.' Some one has said, and I think we shall all echo the sentiment, that "the data communicated by Faraday, as the result of his years of observation of the action of the electric current upon chemical compounds, are among the most important in the history of electro-chemistry. They form the basis of all the quantitative laws which have been developed in this special field. They merit place side by side with the law of combining weights."

Equally important, perhaps, both from a theoretical and practical standpoint have been the results recently won by the introduction of the current into the field of pure chemistry through the persistent efforts of untiring investigators. Mark how in the diffusion of solids in their solvents van t'Hoff perceived a similarity to the expansion of gases; how he succeeded in measuring that diffusive, expansive force bear-

ing the name osmotic pressure; then note the astonishing consequences of this discovery. The simple relation between gas-volume, attending pressure and temperature had led Avogadro to promulgate his hypothesis in regard to molecules—a thought considered by all of us as a fundamental in our science. This hypothesis van t'Hoff made bold to apply to solutions, and there resulted a theory for solutions analogous to that previously wrought out for gases. Today molecular weight determinations are made almost daily in our research laboratories as an indirect consequence of this deduction. Indeed, the laws governing osmotic pressure, when applied in the most varied forms, remained satisfactory, except with solutions of salts, bases and acids. Their osmotic pressure was far beyond what could be expected from the theory of van t'Hoff. How was this to be explained? The answer came from Arrhenius (1887): the departure from the law is due to dissociation, and most astonishing of all is that the dissociation of bodies in their solvents occurs only in the case of those which conduct the electric current, *i. e.*, with electrolytes. Compounds not dissociated in aqueous solution—which adhere to the law of osmotic pressure—do not conduct the electric current. There remained but a step to the assumption that the products of dissociation, in aqueous solution, were identical with the substances termed ions, which in electrolysis appear at the electrodes. A logical query, consequent upon this declaration, was:

Are, for example, free potassium and free chlorine present in an aqueous solution of potassium chloride? Let me read you Ostwald's well-known reply to this question:

"What actually exists in the solution are single potassium atoms with enormous electrical charges. We do not know what these charges are in reality, but this we know, that the chemical properties of substances

are greatly altered by electrical charges. On the other hand, what we know as free potassium is a solid substance whose molecules consist of potassium atoms not charged with electricity at all. \* \* \* As soon as the potassium atoms in solution lose their charge, as they do, for example, when led by an electric current to a platinum wire, where they can give up their electricity, potassium with its ordinary properties is at once produced."

A further consequence of osmosis and that of free ions in solution is Nernst's theory in regard to the electric current in the voltaic cell—the little instrument sent into the world a century ago, from which have come such epoch-making results, so that one cannot help but be profoundly impressed with the time-honored words: 'Despise not the day of small things.'

However, it is not alone in the field of pure chemistry that helpful and interesting consequences of the introduction of the 'subtle agent' are found. The patient, careful analyst, as he struggles to unravel the problems Nature has placed before him, will ever hold sacred the name and memory of our own Dr. Gibbs, who in 1865 first called the attention of the chemical world to that simple yet beautiful and extremely satisfactory determination of copper in the electrolytic way which proved the incentive to further study in this direction, so that at present twenty-one metals lend themselves to electrolytic determination from solutions of the most varied character, and in the same manner at least one hundred and twenty separations have been made, all of which for accuracy, neatness and rapidity leave little to be desired.

In the commercial manufacture of potassium chlorate, potassium persulphate, caustic, iodoform, etc., etc., those who seek to apply the principles of chemistry in the establishment of industries of national import have found in the current a most fruit-

ful aid, the full consequences of which are yet untold.

But it was not to any one of these I especially desired to direct your attention. As indicated by my subject, I had in mind another thought and, craving your further indulgence, I shall at once proceed to a new chapter in this historical *resumé* of electrochemistry.

You are all familiar with the classic experiment made fifty years ago (1848) by Kolbe. I refer to the electrolysis of concentrated solutions of potassium acetate and valerate. You remember that this was the first investigation of its kind in the domain of organic chemistry. The results were most interesting and were thought to have shed a new light upon and given deeper insight into the constitution of compounds. In the case of potassium acetate the course of the decomposition was considered as being fully represented by the resulting products:

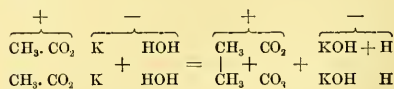

It was held to be a very simple decomposition.

Kekulé, in 1864, gave to the world facts gathered by him in the electrolysis of dibasic acids, *e. g.*, succinic, fumaric, maleic, and brom-maleic acids. The first gave hydrogen and ethylene, together with carbon dioxide; the two isomeric acids gave acetylene, while brom-maleic acid was thought to have yielded brom-acetylene. In 1866 Brester subjected various aliphatic bodies to electrolysis, but obtained nothing new. Aarland next followed with his study of the three isomerides—citraconic, itaconic and mesaconic acids, or the allylene dicarboxylic acids, as they may also be termed. Aarland expected that when these three bodies were subjected to electrolysis they would yield three isomeric allylenes. He also purposed



testing the suggestion of Carstanjen that six isomeric allylenes really existed. Without entering into details, I may say that itaconic acid was electrolyzed with ease; its gaseous products were allylene and carbon dioxide. The residue contained acrylic and mesaconic acids. The resulting allylene was completely absorbed by bromine, but not by an ammoniacal silver nitrate solution. Citraconic acid yielded allylene, containing hydrogen exchangeable for metal and acrylic and mesaconic acids. Similar products were discovered in the electrolysis of potassium mesaconate.

Mesaconic and citraconic acids bearing the same relation to one another as fumaric acid sustains to maleic acid, they, of course, yielded allylene,  $\text{CH}_2 = \text{C} \equiv \text{CH}$ , whereas itaconic acid was resolved by the current into symmetrical allene,  $\text{CH}_2 = \text{C} = \text{CH}_2$ .

As we search further we shall discover that under the influence of the electric current butyric acid was observed to give hexane; valeric acid, octane; caproic acid, decane, etc. Oxalic acid was completely changed to carbon dioxide and water. Malonic acid was resolved into the same components, but the dissociation proceeded less rapidly. Upon electrolyzing an alkaline solution of sodium succinate Bourgoin observed ethylene and acetylene in addition to the customary gas products. Free malic acid was decomposed very slowly; its alkali salts yielded carbon dioxide, monoxide, oxygen, aldehyde and acetic acid. Tartaric acid was broken down into acetic acid. Lactic and sarcosalic acids, in neutral solution, gave acetaldehyde, while in alkaline solution, owing to the condensing power of the alkali, aldol or crotonaldehyde appeared. Glyceric acid was resolved into formaldehyde, carbon dioxide, monoxide and water. In the case of the electrolysis of  $\beta$ -hydroxyacids the rule seems to have been oxidation; the possibility of condensation, however, was not excluded. Formaldehyde was ob-

tained in very appreciable quantities in the electrolysis of a concentrated solution of glycollic acid, whereas in dilute solution the products were carbon dioxide, carbon monoxide and very little formaldehyde.

Let us pause a few moments and consider how these decompositions have possibly occurred. Kolbe considered the course of the action as very evident. The equation previously given represents his idea: "the acetic acid in the field of the galvanic action is oxidized by the oxygen so that it is resolved into carbon dioxide and methyl, both of which appear at the positive pole, while only hydrogen is formed at the negative electrode."

Kolbe, Kekulé and others regarded the decomposition of the organic acid as a secondary reaction. The oxygen arising in the water decomposition they considered exerted an oxidizing effect upon the acid. Bourgoin's researches upon the electrolysis of organic acids were very extensive, and it was the opinion of this investigator that the most important phase in their electrolysis was the production of intermediate anhydrides of the acids. These, Bourgoin thought, then parted with oxygen, and secondary products were formed. In this latter class he included the passage of the anhydride into the acid by water absorption, as well as the oxidation of the acids by the oxygen released from the acid.

These ideas represented by symbols would appear as follows:

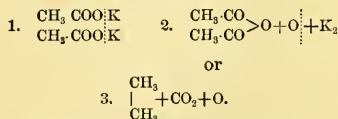

But we continue to ask: Are an anhydride and oxygen formed before the hydrocarbon is produced? If so, does the oxygen then decompose the anhydride with the formation of the hydrocarbon and carbon dioxide?

We are not alone in this inquiry, but L ob has endeavored to find an answer in the experimental way. To do this, he electrolyzed phthalic acid, dissolved in alcohol (a little sulphuric acid was added to increase the conductivity) with a feeble current. The latter was allowed to act for several hours, and there resulted an almost quantitative yield of phthalic anhydride. It is not surprising that this chemist inclines to the view of an intermediate anhydride formation, but he wisely says that this is only demonstrable with acids, whose anhydrides are very stable.

In dealing with the electrolysis of free acids we can scarcely assert that breaking-down occurs, because the acid reappears as such at the positive electrode. Graphically represented we should have:

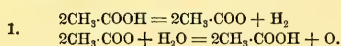

or

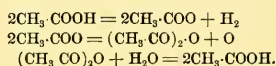

The first equation shows that oxygen comes from the water, while in the second it has its origin in the intermediate anhydride formation.

But let us follow L ob and with him substitute hydrogen sulphide for water, then the equations just written would appear thus:

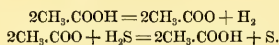

or

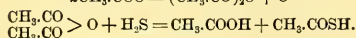
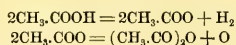

What do these teach us?

1. If an intermediate anhydride is not formed then the original acid will be regenerated and sulphur will separate.

2. If the anhydride is produced an evolution of oxygen will take place, and a

molecule of a thio-acid will be obtained for every molecule of the ordinary acid.

An experiment was performed to test these ideas. Very pure acetic acid was reduced to a low temperature and in this condition saturated with hydrogen sulphide. It was electrolyzed, the gas being still conducted into the solution. Not a particle of sulphur separated at the anode, and the solution contained thio-acetic acid.

Two experiments, therefore, indicated the formation of an intermediate anhydride. However, other views are prevalent. Thus, Schall entertains the opinion that a peroxide is first produced in the electrolytic decompositions of the class we are considering. He electrolyzed the alkali salts of dithio-acids and obtained persulphides of the acids:

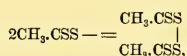

and then the action ceased. It may be because the persulphides are so much more stable than the corresponding peroxides. Schall apparently has been confirmed and indeed antedated in his views, for Bunge in 1870 subjected thio-acetic acid and thio-benzoic acid to electrolysis and obtained acetyl disulphide and benzene disulphide, 'facts which,' the author remarks, 'justify the conclusion that the compound group separating in the electrolysis of the thio-acids, at the anode, is liberated as a complex.'

Hamonet conducted an extensive series of experiments with the alkali salts of the fatty acids. Inasmuch as he worked upon a much larger scale than his predecessors, his conclusions are entitled to thoughtful consideration. They are in substance:

1. The equation expressing the decomposition of salts of the fatty acids as introduced by Kolbe cannot be regarded as correct. Frequently, paraffin hydrocarbons are not obtained, or at least in very small amounts.

2. The olefines predominate in this decomposition.

3. An alcohol with *n*-carbon atoms is invariably formed if the acid contains *n* + 1-carbon, and its structure is not always what we might expect.

So much for the acids. Plainly this particular line of inquiry needs and deserves further attention from the investigator.

The changes induced in organic substances by the electric current are, as a rule, so complex that their study is surrounded by vastly more and greater difficulties than obtain in the electrolysis of inorganic bodies. v. Miller, recognizing this feature, has adopted means of continuously exposing and withdrawing electrolyzed products from the field of action. In this manner he has striven to obtain a more complete picture of what actually occurs under the influence of the current. In the electrolysis of a mixture of potassium acetate and potassium glycollate the product was ethyl alcohol:

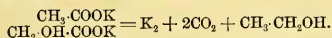

True, the quantity of alcohol was not great, but its formation was certainly very significant. Through the instrumentality of the current even iodine and the nitro-group have been introduced into organic derivatives. Thus, the electrolysis of potassium propionate, in the presence of potassium iodide, yielded ethyl iodide, and that of sodium propionate and sodium nitrite, nitroethane.

Brown and Walker, keeping in view the fact that Kolbe had synthesized hydrocarbons by electrolyzing fatty acids and the additional knowledge that ester groups are electrolytically inactive (first observed by Guthrie), effected some most interesting electrosyntheses, an outline of which is all that I can now give you. They reasoned in this way: If the mono-esters of dicarboxylic acids are electrolyzed, carbon di-

oxide will be eliminated and a diester of some higher dicarboxylic acid will be formed.

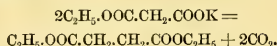

The experiment was performed with potassium ethyl malonate. The concentrated solution of this salt was introduced into a platinum crucible, which served as the kathode. A heavy platinum wire, in spiral form, constituted the anode. The current density approached 300 amperes per square decimeter. A yield of 60% of the theoretically required succinic ester was obtained. They further synthesized adipic acid and sebacic acid. In all of these syntheses secondary changes were noticed, so that it is in no wise surprising that the reaction of Brown and Walker was not entirely successful with the ester salts of unsaturated dicarboxylic acids, in which an ethylene union is present. The ester potassium salts of phthalic acid, of benzyl malonic acid and the salts of oxyacids, such as malic, proved unavailable for synthetic purposes.

I must not omit mention of a rather interesting result, recently communicated by v. Miller and Hofer. As observed, these chemists have entered quite largely into the study of the electrolysis of what may be termed mixtures. They have applied the new method to tricarballic acid with the view of determining constitution. This acid, as you are all aware, is tribasic:



From it we can obtain two different mono-esters, two di-esters and one tri-ester. Quoting von Miller and Hofer freely, I shall say that there is no ordinary chemical procedure which will determine, for example, the position of the ester groups in the di-esters. So these investigators set about



and saponified the triester one-third; they then mixed the potassium salt of the resulting diester with potassium acetate and subjected the mixture to electrolysis. Large quantities of ethyl succinic ester were formed, a proof of the presence of the unsymmetrical diester in the saponification product, for the symmetrical diester would have yielded methyl glutaric ester. The authors went farther. They had obtained a diester acid, constitution unknown, while preparing the triester. The potassium salt of this diester acid they mixed with potassium acetate and electrolyzed as before. The product again gave ethyl succinic ester, showing that the original body was the unsymmetrical diester. These are the first examples of electrosyntheses being used to determine constitution which could not be arrived at in any other way.

Mulliken has also brought to light a new class of electrosyntheses. He has directed his investigation mainly to bodies containing a  $-\text{CH}_2-$  or  $-\text{CH}-$  group, in union with more negative groups. We know that such substances contain hydrogen, which can be replaced by metals. Their sodium salts in alcoholic solution conduct themselves like electrolytes; they break down into sodium and a complex anion—the carbaceous residue. "The products obtained in all the electrosyntheses thus far made are the same one would expect to be formed by the action of iodine on the sodium or silver compounds of the substances electrolyzed:

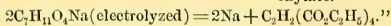
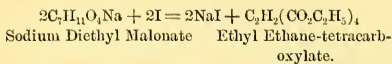

Weems has continued this line of investigation and from his results has felt justified in concluding that the electrosyntheses effected from malonic ester, methin-tricarboxylic ester, acetylacetone and acetoacetic ester are best explained as the result

of the direct union of the anions. "Pairing of anions has been shown to be of particularly common occurrence in the electrolysis of sodium compounds of derivatives of malonic ether." Such pairing has been observed in certain examples of the acetoacetic ester type, but it can scarcely be said to be general. Pairing of anions does not take place in the electrolysis of compounds like acetamide, benzamide, succinimide and phthalimide. The same holds with their sodium and mercury salts.

A very recent synthesis is that of dinitrohexane, a result of the electrolysis of potassium nitroisopropane.

Let us take a cursory glance at the deportment of the alcohols when exposed to the current. Methyl and ethyl alcohol have been electrolyzed with electrodes of platinum and electrodes of other substances, with and without diaphragms. The results have been of the most varied character. In aqueous sulphuric acid solution methyl alcohol gave methyl formate, acetic acid and methyl acetate. Formic aldehyde was not observed. Methane was produced when the electrolyzed solution contained potassium carbonate. Ethyl alcohol, in sulphuric acid solution, gave acetic acid, formic ester and ethyl sulphuric acid. Chlorinated acetic acids were obtained when hydrochloric acid was substituted for sulphuric acid. Glycol in sulphuric acid gave trioxymethylene, glyceric acid, formic acid and an isomeric glucose. Glycerol yielded formic and acetic acids, together with glyceraldehyde. Chloral hydrate, in presence of sulphuric acid, with a diaphragmed cell yielded chlorine and acetaldehyde. The hexahydric alcohols and sugars gave products similar to those obtained from glycerol. Thus, grape sugar was resolved into carbon dioxide, carbon monoxide, trioxymethylene and saccharic acid.

Now turn with me to the aromatic series. It is here that stable nitro-derivatives

flourish, so to speak, and in the reducing side of the current chemists possess a means of attacking these bodies most energetically. Let us take nitro-benzene as the particular subject for consideration. That this yields azobenzene when it is reduced in an alkaline solution, and aniline in an acid solution, are well established facts. Does this hold true when the electric current is the agent of reduction?

The reply to this inquiry divides itself. In an alkaline solution azobenzene and hydrazobenzene are formed. In an acid solution the picture is different from that which is generally supposed to represent the course of the reduction, for Gattermann found *p*-amidophenol. The explanation given for the presence of this body is that when the current reduces nitro-benzene the first product is phenylhydroxylamine,  $C_6H_5NH.OH$ , and that the sulphuric acid present rearranges this compound into *p*-amidophenol. Aniline was invariably found with the latter body. This led Elbs to subject the process to a more careful and critical study. Gattermann considered that the sulphuric acid figures very seriously in the reduction. Indeed, he thought that it played a triple rôle, as it conducted the current, occasioned the molecular rearrangement, and served as the solvent. The question which naturally suggested itself to the inquiring mind was: Could the quantity of this reagent in any manner modify the course of the reaction? Could it affect the yield of the several substances? So it was proposed to substitute acetic acid of varying concentration. The yield grew larger, but that of the aniline increased with the increased amount of *p*-amidophenol. Evidently then aniline could not be considered in this reduction, by the current, as a secondary, but rather as a normal product. A kathode of lead was substituted for that of platinum, and, strangely enough, the quantity of aniline became greater.

Was it possible that the aniline was due to a secondary reduction of the *p*-amido-phenol? or are the lead electrodes responsible for the direct reduction of nitrobenzene to aniline? Experiments made to test the first point demonstrated that *p*-amidophenol, when operated upon with the conditions as before, was not reduced to aniline. After much search it was found that *p*-amidophenol and aniline were produced in equal proportions with platinum electrodes, by prolonging the period of action. Therefore, it must have been the spongy lead which effected the reduction of the nitrobenzene to aniline. Gattermann remained firm in his view that nitrobenzene was first reduced to phenylhydroxylamine, which in turn became *p*-amidophenol, and contended that the latter ought to be obtained entirely free from aniline. However, azoxybenzene had also been detected in the reduction mass, and naturally the thought followed that possibly the *p*-amidophenol was derived from it. The equation which I add will explain this reasoning:

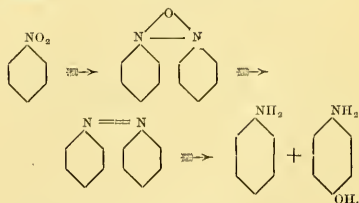

Observe, by adopting this idea of the reduction we can plainly comprehend the presence of both aniline and *p*-amidophenol. Experiment alone could decide whether this was the true course. Accordingly nitrobenzene and azoxybenzene were electrolyzed under similar conditions. The first gave an abundant yield of *p*-amidophenol, while scarcely any of it was obtained from the azoxybenzene. The evidence, therefore, strongly favored Gatter-

mann's original conception, viz.: that the *p*-amidophenol had its origin in the phenylhydroxylamine—the intermediate product. The question continued to interest chemists to such a degree that Löb suspended nitrobenzene in fuming hydrochloric acid or in alcoholic hydrochloric acid, or in mixtures of hydrochloric acid and acetic acid, and reduced it electrolytically. The products were *p*- and *o*-chloraniline. The corresponding bromanilines were obtained when hydrobromic acid was used. Löb and Gattermann concluded then that the reduction was correctly represented in the following equations:

1.  $C_6H_5NO_2 + 4H + HCl = C_6H_5NHCl + 2H_2O$ ,
2.  $C_6H_5NHCl = C_6H_4ClNH_2$ ;  
*o*- and *p*-Aniline

while with Elbs the course of reduction would be represented in this manner:

1.  $C_6H_5NO_2 + H_2 = C_6H_5-N \begin{array}{c} \diagup O \diagdown \\ \diagdown N \diagup \end{array} - C_6H_5 + H_2O$
2.  $C_6H_5-N \begin{array}{c} \diagup O \diagdown \\ \diagdown N \diagup \end{array} - C_6H_5 = C_6H_5N = N. C_6H_4. OH$
3.  $C_6H_5N = N. C_6H_4OK + 2HCl = C_6H_5NHCl$   
+  $HClNC_6H_4OH =$   
 $\frac{C_6H_4ClNH_2}{a} + \frac{C_6H_3(OH)Cl.NH_2}{b}$

A second body, (b) chloramidophenol, should be produced if the view of Elbs was correct. It was, however, at no time discovered in the reaction mass, thus affording additional evidence of the correctness of the first idea. It is not necessary for me to submit all the evidence pointing to the presence of the extremely unstable intermediate compound  $C_6H_5NHCl$ , which rearranged itself into the chloranilines: enough to know that it is very convincing and has been further corroborated by the isolation of the body  $C_6H_5NCl.CO.CH_3$ , observed by Bender.

Gattermann, seeking further support for his views, introduced benzaldehyde into the reduction mixture at the very outstart. He obtained benzylidene hydroxylamine, a con-

densation product previously prepared by Bamberger upon mixing benzaldehyde and phenylhydroxylamine:

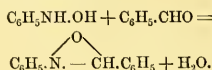

Further, *o*-nitrotoluene and benzaldehyde gave benzylidene-*o*-tolyl hydroxylamine, and *m*- and *p*-nitrotoluenes the corresponding bodies, thus completely establishing the point under discussion. The reduction of nitro-ketones gave the expected derivatives of *p*-amidophenol, *e. g.*, *m*-nitroacetophenone yielded amido-oxyacetophenone—

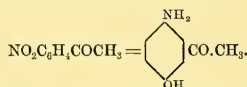

Similar results were realized with *m*-nitrobenzophenone and with *m*-nitrophenyl-*p*-tolyl ketone.

Time forbids more than mere mention of Löb's reduction of the three nitrobenzoic acids and the theory he has proposed in explanation of their reduction; the hydrogenizing of pyridine with the production of piperidine; the obtainment of pipercoline from picoline; the probable reduction of all the higher homologues of pyridine; the conversion of quinoline into its tetrahydride and a trimolecular dihydroquinoline; that of quinaldine to its tetrahydride and trimolecular dihydroquinaldine: Noyes and Dorrance's reduction of nitro-bodies containing substituents in the para-position, as well as the reduction of *p*-nitro-benzoic acid in acid solution by Noyes and Clements; Ahrens' efforts to reduce nitriles to primary amines; the conversion of eugenol into isoeugenol and the electrolytic oxidation of the latter to vanilline; Elbs' oxidation of *p*-nitrotoluene to *p*-nitrobenzyl alcohol; that of nitrosopiperidine to dipiperidyl; that of the toluene sulphonamides to benzoic sulphinides with the formation of saccharin,



and finally the reduction of certain oxy-acids to dyes of great value.

My story is now told, and it only remains for me to acknowledge my deep indebtedness to the various writers upon electrochemistry whose thoughts and words I have freely drawn upon and utilized in preparing this very incomplete sketch of what must be regarded as merely the beginnings of the electrolysis of organic bodies. I feel, however, that you will grant that they have been most fruitful and are, indeed, highly suggestive. It would be presumptuous on my part to suggest, for I am satisfied many new thoughts have come to you in listening, as they have to me, in preparing this review, and to them will be added many more if we will but experiment in the field now opening to us.

I know of no more fitting conclusion to these imperfect and fragmentary paragraphs than the words of Michael Faraday, truly a father of electrochemistry, who said:

"It is the great beauty of our science \* \* \* that advancement in it, whether in degree great or small, instead of exhausting the subjects of research, opens the doors to future and more abundant knowledge, overflowing with beauty and utility to those who will be at the \* \* \* pains of undertaking its experimental investigation."

EDGAR F. SMITH.

UNIVERSITY OF PENNSYLVANIA.

*THE CONCEPTION OF SPECIES AS AFFECTED BY RECENT INVESTIGATIONS ON FUNGI.\**

THE fiftieth anniversary of the foundation of the American Association is a fitting occasion for a retrospective view of the different branches of science represented in our Society, and one would be glad to hear from the lips of some botanist who was

\* Address of the Vice-President before Section G—Botany—of the American Association for the Advancement of Science, August, 1898.

present at the first meeting of the Association an account of the changes which have been brought about in the methods of botanical study and research and of the progress which has been made in North America during the past half-century. Fifty years, however, is a long time in the life of any individual, and of those who in 1848 were young, or comparatively young, even the most favored could hardly be expected to retain their scientific activity in 1898. On glancing over the list of members in 1848 one sees the familiar names of a number of botanists, including Ashmead, J. W. Bailey, Barratt, Jacob Bigelow, Buckley, Dewey, Emerson, Engelmann, L. R. Gibbes, Gray, B. D. Greene, Edward Hitchcock, Oakes, Olney, Pickering, Thurber, Torrey and Tuckerman. Not one of these leaders of American botany in their day remains to tell us of the Association in its infancy and to trace its development with the vividness which personal experience alone can supply.

It would scarcely be fitting in me to attempt to give a general sketch of the part which botany and botanists have played in the life of the Association, nor, remembering the review of recent investigations in botany presented by Professor Marshall Ward at the meeting in Toronto last year, is it desirable that I should encroach on the ground so thoroughly and so interestingly covered by him. I may, however, on this occasion, be permitted to say a few words on a single question on which opinions have changed very much during the last fifty years and, avoiding a detailed history of the subject, treat it somewhat abstractly in its general bearings; for the question, you will admit, is one about which we should occasionally ask ourselves what is probably or possibly true, without, however, expecting in most respects to be able to reach positive conclusions. What do we mean by species? Do species really exist in nature or are they created by us for our own con-

venience? As I do not pretend to be in the position of a philosopher, but approach the subject as a very commonplace sort of a botanist, the word species as used by me means simply species as understood by the systematic botanist and indirectly by those working in other departments of botany who are obliged to depend to a considerable extent upon the limitations of species as defined by systematists.

The publication of the *Origin of Species* in 1859, a date which marks the fall of the old school and the rise of the new, is sufficient to show that it is not probable that any other period of fifty years in the future will have the same comparative historical importance, as far as the question of the conception of species is concerned, as the fifty years we are now commemorating. Had we asked any of the botanical members of the Association in 1848 what they meant by species they would have replied, most of them without reserve, a few with some hesitation, that in the beginning God created all species as he intended them to be and that by searching the naturalist could find them out. Just how they recognized species when they saw them would have been very hard for them to say, as they did not agree in their standards, but they would probably all have agreed in saying that the recognition of species was a matter of individual judgment, one's own judgment, of course, being better than that of any one else. The skeptic at that time could not have failed to notice the frequency with which what was home-made was confused with what was God-given. Before 1859 creation was one vast pudding in which the species had been placed like plums by an Almighty hand, and the naturalists, sitting in a corner like greedy little Jack Horners, put in their thumbs, and pulled out the plums and cried: "See what a great naturalist am I—I have found a new species!"

Probably very few of my hearers have any personal recollection of the time when not to believe that species were fixed and immutable creations was enough to make one a scientific and almost a social outcast. I recall but a few people whom I knew who held these orthodox views, for it was my good fortune to be a student in college at the time of the appearance of what was called 'a new edition of the *Origin of Species* revised and augmented by the author,' published by D. Appleton & Co. in 1864. By that time the novelty and audacity of Darwin's views had ceased to cause a cold shudder, and certainly the students of my time were ready to swallow not only what Darwin had written, but to add a few little theories of their own.

The young botanist of to-day will, I think, pardon me, although my contemporaries may not, if I give a short sketch of the Harvard Natural History Society in the sixties, as showing not only how changed is the position of natural history in American colleges, but also the attitude of college students at that day toward the then new doctrine of evolution. If the Society soon after my college days passed out of existence, its end could not be said to be untimely, for the attitude not only of the university, but of the scientific public, towards the study of natural history had so changed that the old-fashioned society had no place. Those of you who go to Cambridge next Friday may perhaps see a dreary barn-like sort of a lecture room which now occupies the greater part of old Massachusetts Hall. In days gone by, the three upper stories of the hall served as dormitories, and the lower story was occupied by the rooms of the Natural History Society sandwiched in between those of the institute of 1770, which then was pleased to consider itself to be a literary society, and the laboratory of the Rumford Chemical Society, which, as it emitted none of the

odors characteristic of chemical activity, must be considered in my day to have been moribund if not actually defunct.

The rooms of the Natural History Society would now cause a smile. From the low ceiling were suspended an alligator, a turkey buzzard and such other creatures as would not fit well in the wall-cases. In one corner leaned lazily a large cup-sponge, a receptacle for the dust which gravity constantly supplied and the rejecta contributed at frequent intervals by the members. Around the walls was a very promiscuous collection of birds and mammals, some shot and prepared by past members, others the gift of so-called benefactors who, not knowing what else to do with them, turned them over to the Society. Quartz crystals and other showy but not very valuable minerals hobnobbed with skeletons, one of which, at least, must have been very useful, if one could judge by the perennial absence of some of the limbs which had been removed, as was said, for study.

Botany was represented by a single cabinet whose pigeon-holes were filled with plants of New England, enriched by choice fragments of specimens collected by well-meaning persons in the Alps and by travelers in the Holy Land. The plants were arranged, or rather shuffled, in the case according to the wishes or necessity of the curator of the time being. We were quite eclectic in our view of botanical classification, some pigeon-holes being arranged on the Linnæan system, some on the natural system and some apparently alphabetically. Whatever real value the collections may have had, once a year they were at least ornamental. Every year the members were photographed and the alligator, the turkey-buzzard and the human skeleton were taken down and added to the group to show that we were really the Natural History Society and not the Hasty Pudding or the Phi Beta Kappa.

The old collections were long ago dispersed, and the little which was of value is now incorporated with the different university collections. You may, perhaps, be curious to know what the members of the Society did. That is easily told. They all talked and some dissected cats. The talk was to a great extent about the origin of species and, no matter what was the subject of the papers announced for the evening meeting, it was not often that we adjourned without dropping into a discussion on evolution. Few had really read Darwin's book, but all felt able to discuss the great scientific question of the day, in which respects, perhaps, we did not differ from some older and more learned people. Although the traditional man who is always on principle 'on the other side' was not wanting, we were practically unanimous in our opinion. We all felt that a new day had dawned; that the old view of looking at species as fixed creations and ignoring, as far as possible, the significance of their tendency to vary had been forever upset by Darwin, and that hereafter we must look to evolution as brought about by natural selection to interpret species as we now find them. Not being well informed in regard to the history of scientific opinion, we assumed somewhat hastily that before Darwin all was darkness, and we did not trouble ourselves to go back and inquire whether there were not others who had had, at least, glimpses of the great truths of evolution, but even had we heard that there were some before Darwin who did not believe in the fixity of species it would still have been true that it was Darwin's book by which, practically, the world at large was enlightened on the subject.

Forty years have passed and, inasmuch as we are all evolutionists either of the Darwin school or some related school, the question suggests itself, is our belief in evolution merely dogmatic like some of the theolog-



ical doctrines which we believe thoroughly but which we do not allow to interfere with our daily life, or, as far as botany is concerned, has our belief modified the manner in which we treat what we call species? The mere fact that we now recognize that species have been derived from other species, and are on the way to develop into still other species, would naturally lead us to be more liberal in our treatment of them systematically than in the days when variation was almost a crime against the Almighty. Certainly, with evolution as a key to guide us, our conceptions of genera and orders ought to be far more scientific than they were.

A species has been defined as a perennial succession of like individuals and, although no definition is perfect, I doubt whether a better definition of species has ever been invented. It is a peculiarity of definitions, however, that they all need to be defined. In the present case we must be told what is meant by the word perennial and what is meant by like. To the pre-Darwinian, perennial, of course, meant for all time. By the early Darwinians we are not told whether by perennial they meant a hundred, a thousand or a million years, but until, at least, we know approximately what is meant we must still ask how long must be the succession of like individuals to establish a good species. Otherwise the whole matter of the distinction between a race and a species cannot be settled practically. If there is nothing definite in writings of the time of Darwin to explain the limits of the perennial succession, we should bear in mind that the object then was to bring out boldly the salient points of evolution as governed by natural selection, and the illustrations used were taken almost exclusively from the higher animals and plants in which the lives of individuals are of such duration that it was impossible to obtain accurately the records of a large number of generations in any case. Enough was shown

and cited to show from the records of comparatively few generations a general tendency which it was assumed would be confirmed could the geological record be followed, and we can suppose that, so far as they considered the question at all, the early Darwinians took it for granted that the perennial succession needed to establish a species covered very long intervals of time. While one need not object to this method of reasoning, it is plain that the practical question of when a race or variety ceases to be a race and becomes a species was left open, and it is questions of this sort which the systematist is constantly called upon to answer.

What could be learned only slowly and fragmentarily from observations and experiments on higher plants and animals might, perhaps, be learned much more easily could one experiment with organisms whose cycle of life is completed with great rapidity. For this purpose one might suppose that nothing could be better than bacteria, which are easily managed in the laboratory and whose development takes place with such rapidity that it is possible for the experimenter to watch the course of hundreds or even of a thousand generations in a comparatively short time.

The advantage to be expected from studying forms in which the development is very rapid is, however, made difficult for purposes of comparison by their extreme simplicity and the difficulty and, at times, impossibility of finding sufficiently marked morphological characters to guide us and, in the absence of such characters, the bacteriologist is often forced to base what he calls his species on physiological characters, including in that term zymotic and pathological action. By botanists; who are not specially bacteriologists, the so-called species of bacteria are not admitted to be species in the proper sense. Whether scientifically considered they are not as legitimately species

as what are called species in speaking of the higher plants, is a very pertinent question. Any definition of species to be scientifically accurate must in its essential points apply to all plants and all animals and, if a species of flowering plant is a perennial succession of like individuals, it is hard to see why in bacteria a perennial succession of like individuals does not also constitute a species. That the individuals in bacteria are very different from the individuals in flowering plants is certainly true, but that does not affect the question of the validity of the species in the former. As far as the perpetuation of morphological likeness of the individuals is concerned there is no doubt that it is, to say the least, as complete in bacteria as in flowering plants, and the physiological constancy has been shown by competent observers to persist in some cases for hundreds of generations. That these many generations have been produced in months rather than in hundreds of years does not, it seems to me, affect the case.

When, therefore, the botanist denies that physiological species are properly species he is practically admitting that his own definition, the perennial succession of like individuals, is used by him in a special sense, and he does not seem to be aware that species as he limits them are artificial and not natural. The belief that species should be based on morphological rather than physiological characters rests on the assumption that the former are more likely to be inherited and thus show the ancestry, while the latter are more likely to be the result of the temporary attempts of the organism to adapt itself to the environment. It is, perhaps, a question whether the grounds for this belief are as valid as has been supposed. We readily see morphological characters which have been inherited, but it is usually only by accident or experiment that we recognize the physiological or pathological qualities.

Let us turn for a moment from bacteria to Saccharomycetes, whose characteristic function is to invert and ferment the different sugars. Here we have a group much more limited in number of species than the bacteria, but like them microscopic and rapidly growing. Although not long ago they were classified after a fashion on their morphological characters, the admirable investigations of E. C. Hansen and his followers have pointed out the important fact that these characters, taken by themselves, are less fixed, although the limits of their variation may be fixed, than certain physiological characters, such as the maximum and minimum temperatures of growth, and especially the temperature at which spore-formation takes place. It is in these last-named characters rather than in the former that the specific distinctions in Saccharomycetes are sought by those who study that group specially.

The same objection is urged by botanists in this as in the case of bacteria that the so called species are not species but races. We naturally ask, races of what species? There have been many attempts to determine the origin of the common Saccharomycetes, and the question has been supposed more than once to be settled. Without intending to imply that the question is not still open to investigation, I must admit that there does not yet seem to be any satisfactory proof to show from what higher forms Saccharomycetes have been derived. Although there can be no doubt that in the germination of spores of certain fungi, especially the Ustilaginaceæ, bodies are produced in abundance which not only closely resemble Saccharomycetes in shape, but also, in some cases at least, are capable of producing alcoholic fermentation to a limited extent, it does not seem to me that that is by any means enough to warrant the opinion expressed by Brefeld that the Saccharomycetes are derived from and are degener-

ate conditions of Ustilaginaceæ. In fact, one has only to consult Brefeld's own writings to see that Saccharomycetes-like bodies are produced by the germinating spores of other orders of fungi than Ustilaginaceæ, and it is known that, in some species, as in the genus *Aspergillus* and in certain Mucoraceæ, the budding cells which look like the Saccharomycetes, using the word in the limited sense, are also capable of producing alcoholic fermentation.

On the other hand, no one has yet succeeded beyond a doubt in making the Saccharomycetes proper revert to a higher ancestral form. I say beyond a doubt, because the observations of Juhler, Joergensen and Johan-Olsen on the relation of *Aspergillus*, *Sterigmatocystis* and *Dematium* to Saccharomycetes have not been confirmed by other equally good observers, as Kloecker and Schioenning, and, for the present at least, we must regard the observations of Joergensen and Johan-Olsen as affording still other instances of the fact that under proper conditions the germinating spores of many fungi produce bodies like Saccharomycetes, while they do not show conclusively that forms recognized by specialists as genuine Saccharomycetes can be transformed into fungi of other orders. They do, however, show that the views of Brefeld that the Saccharomycetes are derived from Ustilaginaceæ could, at the best, be only partially true.

Let us return to the question as to whether or not species of the Saccharomycetes, as defined by Hansen, for instance, should be allowed to be called species in the proper sense of the word. Of course, no one supposes that they have always existed in their present form and, although we have no exact knowledge of the ancestors of the present species, we naturally suppose that they were derived from some other higher fungi, as the expression goes. Whether derived from one particular order or fungi or from

several different orders, the species as we now see them seem to be constant in the sense in which that word must be used in speaking of species of any group of plants. The shape of the cells in any given species, although variable to some extent, is constant within definable limits and, although they have periods of rest and periods of activity, their physiological action seems to be the same under similar conditions.

We might be justified, it seems to me, in regarding as races the Saccharomycetes-like forms which result from the germination of spores of higher fungi, provided they continued to live an independent existence for a time and were not, as is more likely to be the case, merely accidental conditions depending on unusual or unfavorable conditions of germination, but the Saccharomycetes in the limited sense are constant, as far as constancy is to be expected in living organisms in general; they cannot be made to revert, as far as we know, and I therefore fail to see why they should not be admitted to be scientific species. The same is true of the physiological species of bacteria, meaning, of course, those which have been well studied, and excluding the mass of ill-described and ill-known forms which abound in bacteriological writings. When a race has become so constant that it no longer reverts, and we cannot tell from what species it came, it is no longer a race, but a species.

It may be objected, however, that both bacteria and Saccharomycetes differ from ordinary plants in a most important respect, viz., that there is a complete absence of sexuality and the reproduction is purely vegetative. There are a few botanists, to be sure, who think that there is a form of sexuality in Saccharomycetes, but botanical opinion at present is so overwhelmingly on the other side that to call the question an open one would require an explanation which time will not permit. It may be urged that in plants in which sexuality is



wanting we have no right to speak of a perennial succession of like individuals, for it may be claimed succession means by sexual generation only. This interpretation is very convenient if one wishes to ignore forms like bacteria and Saccharomycetes in the consideration of the question of species, but to exclude them on this ground is somewhat dangerous, unless we are prepared to admit, off hand, that species are purely artificial.

It is the custom to speak of bacteria and Saccharomycetes as degenerate forms. What is meant by this expression is not plain, unless it means that, arising presumably from plants in which sexuality was present, they have become non-sexual. Undoubtedly sexuality is the rule in nature, but it should be borne in mind that it is not universal. I do not refer here to fungi like Ascomycetes and Basidiomycetes which, accepting the hasty conclusions of the Brefeld school, have been, even by a good many of our own botanists, included in the limbo of non-sexual, degenerate forms from which more recent observers are gradually rescuing them. I refer rather to species like *Rhodymenia palmata*, one of the commonest red seaweeds of the North Atlantic, in which, so far, nothing has been discovered but the non-sexual tetrasporic reproduction. This is not an isolated case and others will probably occur to my hearers. Furthermore, we must admit that the number of species normally sexual but in which apogamy sometimes occurs has been perceptibly increased by the studies of botanists in recent years. In such cases as that of *Rhodymenia* it may be that the cystocarpic fruit really exists and will be found later, but, since botanists have searched for it in vain for many years, it must be very rare, and certainly, as far as we know it, the plant is non-sexual.

In regard to cases of apogamy we have not yet sufficient data as to their capacity

for propagating themselves continually apogamously, although in such cases as that of *Chara erinita*, if we may judge by the distribution of the species in central Europe, there seems to be no reason to believe that they may not do so indefinitely. The not inconsiderable number of species of mosses, some of them common species, in which the male or female only is known and the number of marine algæ which, in spite of their frequency, bear only tetraspores or at most bear cystocarps very rarely, should make us cautious in so defining what we mean by species as to imply that we consider that the perennial succession refers only to succession by sexual generation.

We cannot fail to notice an increasing tendency among cryptogamic botanists to give more and more weight to physiological characters in limiting their species. For some time we have been accustomed to think of the species of bacteria as largely physiological, and we are gradually accustoming ourselves to the views of those who hold the same view in regard to species of Saccharomycetes. More recently still we find that in another higher order of fungi, the Uredinaceæ, experts are coming more and more to rely on physiological characters. If in bacteria and Saccharomycetes we have plants which are generally recognized to be non-sexual, in Uredinaceæ the probability is that there is sexuality; at least the probability is here much stronger than in the other two groups. By some the sexuality of Uredinaceæ is considered already proved, but admitting that the form of nuclear union demonstrated by Dangeard and Sappin-Trouffy and confirmed by some other botanists must have some important significance, not only in this, but in other orders of fungi where it occurs, there are reasons for not regarding the union in this case as representing true sexuality. On the other hand, although no one has yet quite proved it, there appear to be reasons

for supposing that, in the æcidial stage, a form of true sexuality occurs comparable with what is known in some ascomycetous fungi. Time alone will show whether this present probability is a reality, but at any rate the position of Uredinaceæ in regard to sexuality is undoubtedly very different from that of bacteria and Saccharomycetes.

One who takes up the recent descriptive works on Uredinaceæ is surprised to see the number of species which depend on physiological characters. The former method of describing the species of this order from the morphological characters of the teleutospore, the uredospore and æcidial stages was certainly sufficiently perplexing, but one almost gives up in despair on seeing species in which the different stages are identical in all respects, except that some of them, usually the æcidia, will grow only on certain hosts. Facts like this are, of course, only determined by artificial inoculations, although they may sometimes be suspected by the distribution of the different stages in nature. In this complicated state of things, more complicated than in any other order of plants, we are compelled to examine very critically the accounts of cultures made even by botanists of high reputation, and it is only natural that we should hesitate to give implicit confidence to negative results unless the observations have been repeated by other observers at other times and places. Even from scattered positive results one should avoid drawing too wide general conclusions. We may readily suppose that some of the supposed distinctions in the choice of their hosts by different Uredinaceæ will be proved hereafter not to be founded in fact, but, making all proper allowances for possible errors in observations and for hasty speculation in a field where speculation is so easy and accurate experiment so difficult, we have to admit that in a good many cases surprising results have been confirmed by repeated ob-

servations and the tendency to split up species on physiological grounds becomes more and more marked.

As the subject is somewhat complicated, it will be well to consider a few prominent cases by way of illustration. An instructive case is that of the Puccinia on *Phalaris arundinacea* referred to, among other subjects, by Magnus and Klebahn in papers published in 1894 and 1895. To the teleutospores was originally given the name *Puccinia sessilis* Schneider, which was found by Winter to bear its æcidia on *Allium ursinum*. Later Plowright experimented with a species which grew on *Phalaris* whose teleutospores could not be distinguished from those of *P. sessilis*, but whose æcidia could be produced on *Arum maculatum* though not on *Allium*. To this physiological species Plowright gave the name of *P. Phalaridis*. Still later Soppit discovered that a Puccinia undistinguishable from *P. sessilis* and *P. Phalaridis* in its teleutospores produced its æcidia on *Convallaria majalis*. To this species he gave the name of *P. Digraphidis*. Had these observations not been confirmed by others we might have doubted whether Winter, Plowright and Soppit had not really experimented with the same species of Puccinia, but, owing to some accident of their cultures, had succeeded in inoculating only different hosts, whereas it might well be the case that the æcidia on the three hosts might by subsequent cultures prove to be the same, and in that case *P. sessilis* would really be only an instance of a Puccinia which produces æcidia on three different hosts, not an infrequent case. The observations of Magnus showed that *P. Digraphidis* bore æcidia also on *Polygonatum* and *Maianthemum*, genera closely related to *Convallaria*. So far as concerned *Polygonatum* and *Maianthemum*, Soppit and Magnus's observations were confirmed by Klebahn. The case is complicated by a difference of opinion as to whether the

æcidium on Paris is connected with *P. Digraphidis* or whether there is not a fourth distinct species, *P. Paridis*, as believed by Plowright.

We need not stop to consider the further history of this complicated case, as it is introduced here merely to illustrate the method and tendency of recent workers in this field. The above-named botanists who studied the species of *Puccinia* on *Phalaris* seem to agree in speaking of *P. sessilis*, *P. Digraphidis* and *P. Phalaridis* as distinct species, although Plowright considered *P. Paridis* to be distinct from *P. Digraphidis*, whereas Magnus considered the two to be what he calls adaptive races (*Gewohnheits-racen*) of the same species. Magnus speaks of the three species as biological species, which he distinguishes from adaptive races, the latter including forms in which, although the æcidium may be produced on different hosts, it does not appear to be so frequent or so well developed on some hosts as on others, showing in the one case that the adaptation is more complete than in the other. Klebahn, although admitting that it is not of real importance whether one regards such forms as the *Pucciniae* on *Phalaris* as species or races, nevertheless states that he sees no reason why they should not be considered to be genuine species rather than races.

Another instance in point is the group of æcidia generally known as species of *Peridermium*, which infest species of *Pinus*. It had for some years been recognized that the æcidial stage of the corticolous form of *Peridermium Pini* was not the same as that of the form on the leaves, but in recent years the subdivision has been carried much farther, owing to cultures made by Klebahn, Edouard Fischer, Rostrup and others. The former has distinguished at least seven species of *Peridermium* on *Pinus sylvestris* alone, whose uredo and teleutospores are to be found in the species of

*Coelosporium* which grow upon different genera of *Compositæ*, *Scrophulariaceæ* and *Campanulacææ*. Although Klebahn is inclined to see minor differences in the shape and markings of the æcidial spores of some of the species, it must be admitted that the differences in some cases are so slight, both in the case of the æcidial spores and the corresponding teleutospores, that were it not that cultures show the connection between the form of one host with that on another to the exclusion of other hosts it is hardly likely that many botanists would consider them as distinct species.

The most suggestive *Uredinacææ* for our present purpose are the different species of *Puccinia* which attack grains and other grasses, for a knowledge of which we are indebted to the researches of Eriksson and Henning in Sweden, whose work is certainly a model of careful investigation. I take it for granted that most of my hearers are already acquainted with the character of the work in question, and we need stop to consider only those points which bear upon the subjects we are discussing. Of the three common rusts which affect grains, *Puccinia graminis*, *P. rubigo vera* and *P. coronata*, the æcidia are to be found respectively in *Aecidium Berberidis*, *Aec. Asperifolii* and *Aec. Rhamni*, according to the previously accepted view in regard to those species. Judging by the morphological characters of the teleutospores and the uredospores alone, these three species occur on a larger number of different grasses. In making inoculations to ascertain the facts in regard to the æcidia of the species, Eriksson and Henning found that what was supposed to be *P. graminis* growing on *Phleum pratense* and *Festuca elatior* had no æcidia, and they described this form under the name of *P. Phlei-pratensis*. *Puccinia coronata* is separated into two species, *P. coronifera* and *P. coronata*, the former having its æcidium on *Rhamnus catharticus*, the latter with æcidia



on *Rhamnus Frangula*, with perhaps two other forms to be separated from the old *P. coronata*. *Puccinia rubigo-vera* is separated into three species, *P. glumarum*, *P. dispersa* and *P. simplex*—the distinctions based largely on the presence or absence of the æcidium, although there are also certain differences in the habit and color of the other stages. The three original species are split up into seven species, besides two uncertain forms, characterized in the main by physiological characters. Furthermore, of *P. graminis*, six specialized forms are enumerated, characterized by differences in the inoculating capacity of the uredo or teliospores on different hosts. The other species also have their specialized forms, the total number being, I believe, twenty-eight. We may consider the specialized forms to be races, and in that case, certainly, we shall have to agree with Eriks-son and Henning in considering their seven species as species rather than races. The important point is to know whether the differences observed are temporary and accidental or permanent. It is too much to ask for the confirmation of the results of these two experimenters just now, for their work is recent and has been carried so far beyond that of previous experimenters that it must require a considerable number of years before we could expect the work to be repeated by others. So far as the experiments have been repeated, as in the case of *P. coronifera* and *P. coronata*, it has been confirmed.

Enough has been said to show that the conception of species by those who are doing the most advanced work in fungi is much more flexible than it used to be, and significance is to be attached to the fact that the number of those who, as viewed by the typical systematic botanist, hold very heterodox views is increasing. The explanation is to be sought in the fact that descriptive botany in certain groups of

plants has reached a point where the ordinary morphological characters no longer suffice to classify what we know or wish to know about the plants themselves. It was my privilege eleven years ago to address what was then the Biological Section of the Association on a subject somewhat related to that of to-day, and my closing sentence then was: "Following the prevailing tendency in business affairs, the question they [botanists] ask of plants is not so much, 'Who is your father and where did you come from,' as 'What can you do?'"

The tendency noticed eleven years ago is even more marked at the present day. As compared with the times of which I attempted to give a sketch in my opening remarks, I think we may truly say that whatever may be the case in zoology, in botany theoretical considerations with regard to evolution play a much less important part than they used to. In the case of such plants as Lycopodiaceæ, Equisetaceæ and their allies and of certain orders of phanerogams the ancestral question naturally remains as important as ever, but, although papers on other orders of plants accompanied by hypothetical genealogies and family trees of the banyan type appear at not infrequent intervals in botanical journals, they are quite overshadowed in general interest by the papers on cytology, life-histories and physiology. That was not the case in the sixties, when nothing compared in interest with the question of the origin of species. While we cannot be too grateful to Darwin for having opened our eyes to see the value of evolution in general, the majority of the active botanists of the present day find too many other pressing questions to be solved to be able to dwell on evolution to the same exclusive extent as did the botanists of the last generation.

Our definition of a species included two terms which required further explanation.

We started out in the hope of finding some light as to the approximate length, or, at least, the approximate minimum of the length, of time which is needed to transform a race into a species, hoping that perhaps those plants in which the development of the individual was rapid might show that in a comparatively short space of time a race might be actually observed to become fixed and be considered a species, a fact which certainly could not be so well ascertained by direct observation in the study of the higher plants alone. You will notice that, like the obliging shopkeeper, I have not given you exactly what you expected, but have offered you instead something else perhaps just as good, if not better. If I have not been able to tell you that in such simple and quickly growing plants as bacteria and *Saccharomyces* new species can be produced from old ones in a comparatively short time, a consideration of some of the peculiarities of such plants has brought out the modifications which have taken place in the views of a good many as to specific limitations, which is in part an answer to our primary question, What do we mean by a species?

It may be added that although some of the species of lower plants may be transformed in various ways by artificial cultures, on the whole, we are quite as much struck by their comparative constancy in important respects as by their tendency to differentiate. In *Uredinaceæ* there is a tendency to form adaptive races, which is greater than was formerly supposed, but whether the tendency is greater than would be found in some higher plants, were they studied as carefully as have been the *Uredinaceæ*, is perhaps a question. Parasites, as a rule, are more plastic and more sensitive to changes of environment than other plants, and their impressionability, if I may use that word, might be expected to accentuate their power of specific transformation.

It cannot be denied that there is a general suspicion—to say knowledge would be too strong—that the lower plants become specifically changed more easily and quickly than the higher, but, although this is what we should expect from their more rapid individual growth, I am not able to cite any actual observations which can settle the question, for, as you know, the school of botanists which may be called the school of ready transformationists have a fatal tendency to accept unskillfully conducted or otherwise faulty observations as convincing proof. Others, it is to be feared, err on the other side and are not sufficiently ready to admit metamorphoses in different species of the lower plants. Probably the truth lies between the two. The metamorphoses to which I now refer are, of course, in the normal cycle of individual development and should not be confused with the differentiation into races and species, but of necessity our views as to the latter must be influenced to some extent by our attitude towards the former.

If we turn to the second word of our definition which needed explanation, and attempt to say what is meant by like individuals, we find ourselves wholly at sea. Even if we agree that the likeness must be morphological and not physiological, that does not help the matter at all. No two individuals are ever absolutely alike in morphological characters, and the question is one of comparative likeness only. Systematists may agree that certain characters are more important than other characters, but they would never agree as to what characters are important enough to be regarded as specific in comparison with those which are only racial. In fact, when we come to the point, we find that most systematists do not in practice distinguish species from races on the ground that the former are practically constant, whereas the latter are not, but rather on the ground that they regard the

characters which they use to distinguish species as more important than those which they are willing to accept as merely racial.

But what is more important or less important is a question not only of individual opinion at any given time, but it is also a question which depends on the means of analysis at our disposal, and these change from time to time. Surely there never lived a better systematist than Elias Fries, and, at the time of its publication in 1821-1832, his *Systema Mycologicum* was certainly a masterpiece. If the species described by him in genera, such as *Sphæria*, for example, which were then considered valid, are no longer recognized as such, it is not because in limiting his species as he did Fries did not employ with remarkable skill the same scientific principles of classification as the mycologists of to-day, but mainly because the modern application of the microscope to the study of the spores and some other characters has brought out facts unknown in the beginning of the century. The species of Fries have been split up and changed in many respects, and while we feel sure that the modern classification, thanks to improved microscopes, is an improvement on his, who shall dare say that hereafter some at present unknown and unsuspected method of analysis may not furnish facts which will overturn our present system?

I should feel that I ought to apologize for bringing up a subject so very, very threadbare, were it not that some botanists shrink from acknowledging the fact that what we botanists call species are really arbitrary and artificial creations to aid us in classifying certain facts which have accumulated in the course of time, and nothing more. So long as we entertain even a lingering suspicion that they are anything more, systematic botany will not be able to accomplish its real object, which is certainly very

important. We are all convinced, theoretically at least, that not only are all plants gradually changing, and sooner or later will no more be what they now appear to us to be than they are now what they were in times past, and we also know that the means which we have of studying them are changing as well. Our so-called species are merely snap-shots at the procession of nature as it passes along before us. The picture may be clear or obscure, natural or distorted, according to our skill and care, but in any case it represents but a temporary phase, and in a short time will no longer be a faithful picture of what really lies before us, for we must not forget that the procession is moving constantly onward and at a more rapid rate than some suspect. Better cameras will be invented, and when another generation of botanists snap off their pictures they will undoubtedly look back with pity, if not with contempt, on our faded and indistinct productions.

Whether or not species really exist in nature is a question which may be left to philosophy. Our so-called species are only attempts to arrange groups of individual plants according to the best light we have at the moment, knowing that when more is known about them our species will be re-modeled. We should not allow ourselves to be deluded by the hope of finding absolute standards, but it should be our object to arrange what is really known, so that it can be easily grasped and utilized. Utility may, perhaps, sound strange and may seem to some to be a very low aim in science, but in the end utility will carry the day in this case, for systematic botany is a means, not an end. Its true object should be to map out the vegetable kingdom in such a way that all known plants are grouped as clearly and distinctly as possible in order that the horticulturist, the forester, the physiologist may be able to obtain the facts needed by them in their work. Our pres-



ent knowledge may not be sufficient to enable us to draw all the contours sharply or to lay down accurately all the lines, but our work certainly should not be blurred by subtleties and purely metaphysical refinements. The best systematist is not he who attempts to make his species conform to what he believes to be the ideal of nature, but he who, availing himself of all the information which the histology, embryology and ecology of the day can furnish, defines his species, within broad rather than narrow limits, in clear and sharply cut words which can be readily comprehended and do not force one to resort to original and perhaps single specimens to learn what the author of the species really meant.

The end which we all wish ultimately to reach is a knowledge of how living plants act, but in the process of obtaining this knowledge it is necessary to call to our aid not only the physiologist, but also the systematist and the paleontologist, for there are many questions ultimately to be settled by the physiologist for which the information furnished by the systematist must serve as a basis, and the geological succession must be supposed to throw some light on present conditions. It is no disparagement to systematic botany to say that it should look towards physiology as its necessary supplement, for, on the other hand, physiology must lean on systematic botany in attempting to solve many of its problems, and the scientific basis of both rests on histology, morphology, in the modern sense, and embryology. The qualifications needed in a physiologist are so different from those required in a systematist that no one is warranted in speaking of one as of a higher grade than the other. If it has become the fashion in some quarters to assign the systematist to a secondary place it cannot be attributed to the fact that his work is necessarily inferior in quality, but is rather due to the fact that, in too many

cases, systematists have failed to recognize what should be the legitimate aim of their work.

The utilitarian tendency is well shown by what has been said in speaking of bacteria and Saccharomycetes. Did time permit, and were the subject not one which would not readily be followed with patience by an audience at this late hour, other instances, especially in Ustilaginaceæ, might be given to illustrate further the point in question. The bacteriologist bases his species on grounds which he thinks best suited to enable him to group together intelligently the plants he is studying, and it is nothing to him that others say that his species are not species, but races. After all, the question whether certain forms are to be considered species or races is in many cases merely a question of how much or how little we know about them. The races of one generation of botanists often become the species of the next generation, who, as they study them more minutely and carefully, discover constant marks not previously recognized. As systematic botany develops in the future it may very well become the study of races rather than species, as we now consider them. In some cases, as in the Uredinaceæ, the time may be not far distant when this condition of things will be reached. We also feel warranted in believing that hereafter physiological characters will assume even a greater importance than at present in the characterization of species. If there are some among my hearers who do not agree with me as to the importance to be attached to utility, I think that we shall all agree that in discussing the work of botanists in other departments than our own it would not be wise to exact a rigid conformity to our individual conceptions of species as distinguished from races.

W. G. FARLOW.

HARVARD UNIVERSITY.

THE BRITISH ASSOCIATION FOR THE ADVANCEMENT OF SCIENCE.\*

On September 7th the British Association met in Bristol for the third time since its foundation. It met there very early in its career—in 1836—when the Marquis of Lansdowne was President. Among the distinguished men of the period who were present in an official capacity were Whewell, Buckland and Henslow, and the total attendance was 1,350. The Association met again at Bristol about forty years later—in 1875—when the Presidential chair was occupied by the eminent engineer, Sir John Hawkshaw. Many distinguished scientific men were present, the total attendance being 1,951. There were registered early in the week for the present meeting 2,284 members and associates. The Bristol authorities and the local officials did everything in their power to render the meeting at least a social success. Besides the usual *conversazione*, there were one or more garden parties, and visits to places of interest in the city and neighborhood every day, not to mention private dinner parties. On Friday evening, September 9th, there was a symposium in the Merchant Venturers' Technical College. On Saturday, September 10th, there was a public banquet arranged by the President and members of the Bristol Chamber of Commerce. On Tuesday, September 13th, there was another banquet given by the Master and Society of Merchant Venturers. A Biological Exhibition was held in the Zoological Gardens, the opening ceremony being performed by Sir John Lubbock on the afternoon of the 8th. Some two dozen manufactories, works, etc., were open to the inspection of members, besides a variety of institutions and places of interest. Eight excursions were arranged for Saturday, the 10th, and other eight for Thursday, the

15th. At the end of the meeting, September 16th to 20th, there was a five days' excursion to Exeter, Torquay, Plymouth and Dartmoor.

The President of the Association, Sir William Crookes, in his address\* dealt with the subject of the Supply of Wheat to the United Kingdom and then to the whole civilized world. He discussed methods of fixing atmospheric nitrogen and converting it into valuable manure. He then proceeded to deal with more purely scientific subjects—the liquefaction of hydrogen, the constitution of matter at absolute zero, the newly discovered gaseous elements, the Zeeman phenomenon, Röntgen ray discoveries, practical and theoretical, cathode rays and the fourth state of matter, Uranium and Polonium rays, unsuspected sources of energy, spectroscopy, and a new element—and ended with a discussion of psychical research.

Section A (Mathematics and Physics) was presided over by the distinguished physicist Professor W. E. Ayrton, F.R.S., whose ingenious inventions and applications are well known. His address was largely concerned with the diffusion of smells. On Thursday, the 8th, the International Conference on Terrestrial Magnetism and Atmospheric Electricity assembled and Professor Rücker delivered an address. The meeting of this conference will be regarded as part of Section A, but separate sittings were held each day. Saturday's sittings were devoted to mathematics and meteorology, and papers on experimental electricity were taken on Tuesday. A joint meeting of Sections A and B (Chemistry) for the discussion of results of the recent solar eclipse expedition was held on Monday.

The President of Section B (Chemistry) was Professor F. R. Japp, of Aberdeen Uni-

\* This address will be published in SCIENCE as soon as space permits.—ED.

\* Based on articles in the London *Times*.

versity. The subject of his address was 'Stereochemistry and Vitalism.' He discussed Pasteur's researches in molecular asymmetry, aimed to demonstrate the correctness of his belief now generally questioned by chemists, that life is necessary for the production of optically active organic compounds. Professor Japp deduced from Pasteur's results the inadequacy of any interpretation of the phenomena of life which is based solely on the mechanics of atoms. In the general sectional proceedings Professor Ramsay and Dr. Morris Travers gave an account of their recent discoveries, especially in reference to 'Neon,' one of the three new constituents of the atmosphere, and Professor Sidney Young reviewed his physico-chemical investigations under the title of 'Some Researches on the Thermal Properties of Gases and Liquids.' Among points of more general interest included in the paper was the fractional distillation of liquids and an extended study of the subject in relation to the separation of pure hydrocarbons from American petroleum. Dr. W. J. Russell gave an account of his work on the action of certain peculiar and special radiations from metallic surfaces upon photographic plates. Bristol offered special attractions to chemists on account of the interesting chemical works in its neighborhood.

Section C (Geology) was presided over by Mr. W. H. Huddleston, F.R.S. His address dealt mainly with certain points in the geology of the Southwest of England, east of Dartmoor. Special attention was directed to the survey map on the scale of four miles to an inch, which has lately been issued. The principal alterations were briefly discussed. Accepting Bath as a center with a radius of about fifty miles, attention was drawn to the great variety of geological formations within that area—a variety not to be matched elsewhere in an equal space. Some of the results of recent observations

were recorded, and certain peculiarities, long known in connection with the district, noticed—for instance, the passage of the old red sandstone into the Devonian, and, again, of the Carboniferous limestone into part of the culm-measures. Even in Mesozoic times the contrast presented by the inferior oolite of Dundry to that of the Cotswolds has given rise to much discussion. In tectonic geology, likewise, the Gloucestershire coalfield exhibits a remarkable change in the strike of the beds, indicating that two distinct systems of movement must have been at work within that area. The possible evidences of glacial action in the Cotswolds was discussed, and brief mention was made of the more recent changes which are known to have taken place in the estuary of the Severn.

Among the papers promised for this Section were the following: Professor Hull, F.R.S., 'On the Sub-Oceanic Physical Features of the North Atlantic;' Mr. A. Strahan, 'On the Revision of the South Wales Coalfield by the Geological Survey;' Mr. E. B. Wethered, 'On the Building of the Clifton Rocks;' Mr. S. S. Buckman, 'On the so-called Midford Sands;' Mr. H. B. Woodward, F.R.S., 'On Arborescent Markings in Carboniferous Limestone;' Professor Lloyd-Morgan, 'Some Notes on Local Geology,' and the Rev. G. C. H. Pollen, 'On the Further Exploration of the Newydd Caves, North Wales.' Professor Hull's paper brought forward additional evidence in favor of the author's well-known views on Continental elevations. Professor Lloyd-Morgan's paper on the local geology was an invaluable introduction to the excursions. The long excursion to Exeter and Dartmoor at the close of the meeting was also one of special interest for geologists.

Professor W. F. R. Weldon, F.R.S., presided over Section D (Zoology and Physiology). In his address he urged the necessity of a statistical treatment of the problems



arising in connection with variation, inheritance and selective destruction among animals, and spoke of the results already obtained in this direction (especially by Mr. Francis Galton and Professor Karl Pearson in the treatment of variation and inheritance. This aspect of zoological problems received a good deal of attention at Bristol. Dr. Galton and Professor Poulton read papers which bear upon it.

The President of Section E (Geography) was Colonel George Earl Church, and the subject of his address was 'Argentine Geography and the Ancient Pampean Sea.' He aimed to show that the Plata drainage area was in a recent geological period much more extensive than it is to-day; that its most northern limit was  $10^{\circ} 44'$  south latitude, and that nearly the entire waters which now unite to form the Madeira river, the main affluent of the Amazon, once flowed southward into a Pampean Sea, which penetrated 1,400 miles inland, north to almost  $19^{\circ}$  south latitude. Incidentally Colonel Church dealt with various topics of interest in connection with the past and present hydrography and physical geography of South America. Among other points he maintained that a great ancient lake (115,000 square miles) was formed in the valley of the Beni and Mojos after the latter was cut off from its southern connection with the Pampean Sea. The sensation in this Section was the account which M. de Rougemont gave of his 30 years' residence among the savages of central Australia.

The President of Section F (Economic Science and Statistics), Dr. J. Bonar, in his address dealt with 'Old Lights and New in Economic Study;' according to the program, Mr. G. E. Davies, of Bristol, was expected to read a paper on 'Sugar in Bristol;' Mr. J. O. Galloway, of Manchester, on 'Shipping Rings and Corners;' Mr. A. L. Bowley on 'Wages;' Professor A. W. Flux on

'Saving and Spending;' Miss Clara Collet on 'Expenditure of Middle Class Working Women;' Mr. H. H. Vivian on 'Labor Copartnership;' Mr. L. L. Price on 'The Bimetallic Ratio;' Mr. C. S. Loch on 'Poor Law;' Mr. E. Cannon on 'Municipal Enterprise;' and Mr. G. Pearson on 'Electrical Enterprise and Municipalities.'

Section G (Mechanical Science) was presided over by Sir John Wolfe-Barry, K.C.B., F.R.S., who in his address touched upon the growth of British shipping and the recent and future demands for dock accommodation throughout the kingdom, with some reference to the city of Bristol in this connection. He also adverted to the necessity of further facilities for experimental research and to the work of the committee which has recently been sitting, on the nomination of government, in order to inquire into and report on the establishment of a national physical laboratory. In the general proceedings of the Section there were one or two interesting discussions.

The President of Section H (Anthropology) was Mr. E. W. Brabrook, C.B., and the main subject of his address was the unity of the anthropological sciences. In the treatment continuity is assumed, and Mr. Brabrook gave a practical turn to anthropology by suggesting an ethnographical survey of the Empire. The President's address was followed by a number of papers on folk-lore and comparative mythology.

Section I (Physiology) was combined with Section D (Zoology). Section K (Botany) was presided over by Professor F. O. Bower, F.R.S., the subject of whose address was the homology of the members of the plant body at large, but with special reference to that question of homology involved in the alternation of generations in green plants. The position arrived at was that the facts, such as those relating to recently-discovered anomalies, are in accord with a theory of antithetic alternation. In the sectional

proceedings there was a discussion on 'Alternation of Generations,' opened by Dr. Lang, of Glasgow University. Dr. F. F. Blackman, of Cambridge, gave a lecture of a semi-popular character on the 'Lungs of Plants.'

The Friday evening lecture was by Professor Sollas, F.R.S., on 'Funafuti—the Study of a Coral Island,' and the Monday evening lecture by Mr. Herbert Jackson on 'Phosphorescence.' The lecture to workmen on Saturday evening was by Professor Poulton, F.R.S., on the 'Ways in which Animals Warn their Enemies and Signal to their Friends.'

The report of the Council of the Association to the General Committee nominated Professor Rücker as trustee in the room of the late Lord Playfair, the other trustees being Lord Rayleigh and Sir John Lubbock. The establishment of experimental agricultural stations, of a hydrographic survey of Canada, the adoption of civil reckoning for astronomical purposes and the establishment of a Bureau of Ethnology under the auspices of the British Museum were reported upon.

In accordance with the regulations, the retiring members of the Council are Professor Edgeworth, Mr. Victor Horsley, Mr. G. J. Symons and Professor W. Ramsay. The Council recommend the re-election of the other ordinary members of the Council, with the addition of Dr. W. H. Gaskell, F.R.S.; Dr. J. Scott Keltie; Major P. A. MacMahon, F.R.S.; Mr. L. L. Price and Professor W. A. Tilden, F.R.S. An invitation to hold the annual meeting of the Association in the year 1900 at Bradford, and an invitation from Cork for a future meeting, were received.

Professor Rücker, the General Treasurer, showed in his report for 1897-98 that the receipts amounted to £4,623 and the expenditures to £2,920, leaving in hand a balance of £1,703. The investments amounted to £11,137.

#### NOTES ON INORGANIC CHEMISTRY.

Two years ago Moissan described a carbide of tungsten of the formula  $W_2C$ , prepared by heating the metal or its oxide with excess of carbon in the electric furnace. In a recent *Comptes Rendus* P. Williams describes a new carbide of tungsten which has the formula  $WC$ . It is formed by heating a mixture of tungstic acid and carbon with iron in an electric furnace or even by means of a powerful forge. The carbide differs from that of Moissan by being unattacked by chlorine even at a red heat. It is harder than quartz and is extremely difficult to decompose, water and hydrochloric acid having no effect upon it at high temperatures; it is little affected by other acids. In these respects it differs very materially from most of the known carbides.

To the last *Zeitschrift für anorganische Chemie* A. Piccini contributes a study of the alums of titanium, formed by reduction of titanous acid by the electric current in the presence of sulfuric acid and an alkaline sulfate. Piccini calls particular attention to the advantage of using cesium and rubidium salts in forming alums difficult to crystallize, owing to the comparative insolubility of cesium and rubidium alums. A very similar study was carried out at Washington and Lee University last year by Mr. E. A. O'Neal, and an account of it presented by me to the Chemical Section of the American Association at the Boston meeting. The conclusions reached were like those of Piccini. The cesium and rubidium alums of iron and cobalt were described in our paper.

As an appendix to his paper Piccini describes the cesium manganese alum formed electrolytically. Potassium and ammonium manganese alums were described by Mitscherlich. Repeated efforts have been made in the Washington and Lee Laboratory to form them according to Mitscherlich's description and in other ways, but without

success. The same has been the experience of other workers, notably Franke and Christensen. The latter, indeed, bases an argument as to the chemical character of manganese on the non-existence of manganese alums. In working with manganese, O'Neal, though using apparatus similar to that just described by Piccini, was not so fortunate as to obtain definitely a manganese alum, but now that it has been obtained by Piccini there would seem to be no doubt of the existence of trivalent manganese in salts of oxy-acids.

THE cause of color in the sapphire has been ascribed to various substances, but the weight of authority seems to favor the presence of chromium, probably in the form of a lower oxid. Deville and Debray, who carried out many experiments on the subject, are quite positive that chromium is present. The effort has been made by Andre Duboin to form chromium glasses of a blue tint, and his results are described in the *Chemical News*. Mixtures of silica, alumina, lime and chromate of potassium were heated to redness for several hours in a crucible brasqued with charcoal. With this mixture only a dull blue tint was obtained. When, however, the lime was wholly or partially replaced by baryta a fine blue color resulted. Jena glass and other boric-acid glasses were also colored blue by chromium. Calcium carbid, used instead of charcoal as a reducing agent, gave blues, but less fine. Of common glasses, soda glass gave only a green and Bohemian glass a bluish violet, but only in the vicinity of the layer of charcoal. It would, therefore, seem to be quite possible that the blue of sapphire is a lower oxid of chromium.

J. L. H.

#### CURRENT NOTES ON ANTHROPOLOGY.

##### THE TRENTON ICE MAN.

THE meeting of the Anthropological Section in Boston was noteworthy for the

absence of palæolithic man. He did not attend in person or by representative. Probably he modestly felt that he had been too much in evidence at Toronto. But in the last number of *L'Anthropologie* (No. 3) the Marquis de Nadaillac, supported by some new material furnished by Professor Putnam, says a good word for his quondam existence at Trenton.

This new evidence is the exhumation by Mr. Volk of argillite chips below the ferruginous layer in the sands. This proves, reports the Marquis, that the sands above and below that layer are of the same age, and both glacial.

If I read the testimony printed in *SCIENCE* aright, it proved, indeed, that both were of the same character, and that both were eolian and distinctly long *post-glacial*.

##### ANCIENT MEXICAN MIGRATIONS.

IN a recently published quarto of ninety-two pages the Count de Charencey, well known for his many valuable contributions to American linguistics, presents a careful study of the statements in Sahagun's History concerning the traditional migrations of the Aztecs and Toltecs. He compares the old monk's account, which he no doubt justly assumes was the popular tradition of the time, with those of other writers, such as Veitia, Tezozomoc, Ixtlilxochitl, and also with the renderings of the Codices.

The result is a critical and valuable contribution to the subject. He does not credit the interpretation of those who trace the migrations across continents, but rather holds that Sinaloa or Jalisco limited the horizon of the tale-tellers; though somewhat inconsistently, he thinks that some of the narratives had an Asiatic origin (p. 34). (*L'Historien Sahagun et les Migrations Mexicaines*. Alençon. A. Herpin, 1898.)

##### THE COLOR OF THE AMERICAN INDIAN.

IN the *Zeitschrift für Ethnologie*, 1898, Heft 2, Dr. Karl E. Ranke has an article on the



color of the South American Indians. His observations lead him to the following conclusions: 1. The darker coloration of portions of the body is due to exposure to sun and air, resembling in this the white race. 2. Judging from the color of the protected portions of the skin, the South American Indian approximates more closely to the yellow race than to the white or to a red race.

In the discussion of the paper when read in the Berlin Anthropological Society, Dr. Staudinger observed that variations of color under exposure is largely individual in all races, some negroes burning darker, some Europeans not 'tanning' at all; a fact well-known among ourselves.

D. G. BRINTON.

UNIVERSITY OF PENNSYLVANIA.

#### SCIENTIFIC NOTES AND NEWS.

THE grants made for scientific purposes at the recent Bristol meeting of the British Association amount to £1,495.

AT the recent Congress of Physiologists a committee was appointed, at the suggestion of M. Marey, to consider methods of standardizing and making comparable physiological instruments. The committee consists of Professors Bowditch, Foster, von Frey, Hürthle, Kronecker, Marey, Mislawsky, Mosso and Weiss. The members of the committee are expected to secure information in their respective countries, and will meet in M. Marey's laboratory at Paris in September, 1900.

THE Library and Natural History Museum of New Westminster, B. C., was totally destroyed by the fire which consumed that city on September 11th.

A FULL-SIZED *replica* of the well-known portrait of Huxley painted by the Hon. John Collier in 1883 has been presented by Mr. Collier to the trustees of the National Portrait Gallery.

HERBERT LYON JONES, associate professor of botany at Oberlin College, died at Granville, O., on August 27th, at the age of 32 years. He had held this position but a single year, coming

from Cambridge, where he had been an instructor in Harvard and Radcliffe Colleges for a number of years.

THERE will be a general conference of the International Geodetic Association at Stuttgart, beginning October 3d. Besides the usual reports from the different countries on progress made toward the measurement of the Earth, a number of important questions will come up for discussion. It is expected that the program for a systematic study of the variations of latitude, involving the occupation of stations for a term of years, will be definitely arranged. Two of the points will be in the United States, one in Japan and one in Italy. The latest acquisition to the Association is England, which will be represented this year for the first time. Mr. Preston, of the Coast and Geodetic Survey, goes as the delegate from the United States.

THE Italian Congress of Public Health will meet in Turin from September 29th to October 1st under the presidency of Professor Pagliani.

THE Fifth International Congress of Hydrology, Climatology and Geology will be held at Lüttich from September 25th to October 3d, 1898.

THERE were only 322 members in attendance at the Nantes meeting of the French Association for the Advancement of Science, although the membership of the Association numbers some 4,000. Complaints are also made that the leading French men of science do not attend the meetings. There was, with the exception of the President and Vice-President, only one member of the French Academy of Sciences present at the meeting, and he did not take part in the proceedings.

It is stated in *Nature* that 226 members were in attendance at the recent International Congress of Physiology. The different nationalities represented were as follows: Austria-Hungary and Germany, 33 members; Belgium, 9; Denmark and Sweden, 3; Egypt, 2; France, 29; Holland, 3; India, 2; Italy, 9; Japan, 4; Roumania, 2; Russia, 7; Switzerland, 9; United States, 16; Great Britain and Canada, 98.

THE Scientific Commission, appointed jointly by the Colonial Office and the Royal Society to

investigate the mode of dissemination of malaria with a view to devising means for preventing the terrible mortality which now takes place among Europeans resident in tropical and sub-tropical climates, has now been nominated. It will consist, according to the *British Medical Journal*, of Dr. C. W. Daniels, of the Colonial Medical Service, British Guiana, who is well known for the many valuable contributions he has made to tropical medicine; Dr. J. W. W. Stephens, formerly Lawrence student in pathology and bacteriology at St. Bartholomew's Hospital, and the author of the essay on the Bacteriology of Asiatic Cholera in Allbutt's 'System of Medicine,' and Dr. R. S. Christophers, of University College, Liverpool. Dr. Daniels will proceed at first to Calcutta, where he will acquaint himself practically with the remarkable work which Surgon-Major Ross, of the Indian Medical Service, is carrying on into the relation of mosquitos to the dissemination of malaria. Drs. Stephens and Christophers will at first proceed to Rome, where they will spend some time in studying malaria. Subsequently the Commissioners will meet together at Blantyre, British Central Africa.

WE learn from *Nature* that the Tenth Congress of Russian Naturalists and Physicians was opened at Kieff on September 3d, with an attendance of nearly 1,500 members, under the presidency of Professor N. A. Bunge. The Presidents of the different sections were the following professors: Mathematics, V. P. Ermakoff; Sub-section of Mechanics, G. K. Susloff; Astronomy, M. T. H. Khandrikoff; Physics, N. N. Schiller; Sub-section of Aeronautics, N. E. Zhukovsky; Chemistry, N. A. Bunge; Mineralogy and Geology, K. M. Feofilaktoff; Botany, O. K. Baranetsky; Zoology, N. V. Bobretsky; Anatomy, Physiology and Medical Science, M. A. Tikhomiroff; Geography and Anthropology, V. B. Antonovich; Agriculture, S. M. Bogdanoff; and Hygiene, V. D. Orloff. Two papers were read at the first general meeting: one by Professor Bugaëff, on the philosophical purports of mathematics; and the other by Professor Mendeléeff, on the oscillations of the balance.

THE Geologist's Association of London, says

*Natural Science*, held their long excursion in the Birmingham district from July 28th to August 3d, under the directorship of Professors Lapworth and Watts, Dr. Stacy Wilson, and Messrs Jerome Harrison and Wickham King. Messrs. Sollas, Blake, Sherborn and Miss Wood, of Birmingham, were among the fifty or sixty persons present. Mr. Frederick Meeson acted efficiently as Excursion Secretary. The main attraction of the excursion was the comparison of the Archean and Cambrian rocks of the district with those seen on a previous occasion in the Shrewsbury area under the same directors. The basic dyke in Abel's Quarry, near Nuneaton, penetrating the Archean, but cut off by the overlying Cambrian Quartzite, was an object of much interest, while the Hyolithes beds of Cambrian age yielded sparingly *Kutorgina*, *Hyolithes* and other fossils. The remarkable bending of the edges of the Menevian beds underlying the Carboniferous conglomerate was examined in detail, and the theory of the movement of soil-cap was held to be sufficient to account for it without calling in any more violent means. The geologists were shown, by Professors Lapworth and Watts, the imaginary restoration of the old Triassic sea, with its islands of Charnwood, Nuneaton, Lickey, Shrewsbury, etc. The head of a trilobite was found for the first time in the Lowes Stockingford Shales, thus helping forward the elucidation of the life of the period. The last day an excursion was made to the Dudley and Wren's Nest Silurian, and owing to the excellent arrangements made by Mr. Cloughton the workings were explored in boats in a most complete manner.

OWING to his absence in Colorado, where he will be occupied in inspection of forest reserves until November, Mr. J. G. Jack will not give his usual course of lectures at Arnold Arboretum on trees and shrubs this autumn.

DR. F. W. DAFERT has been appointed Director of the Agricultural Chemical Station in Vienna.

DR. VOGES, assistant in the Berlin Institute for Infectious Diseases, has been appointed Director of the Bacteriological Institute at Buenos Ayres.

THE Welby prize of £50, offered for the best essay on 'The Causes of the Present Obscurity and Confusion in Psychological and Philosophical Terminology and the Directions in which we may hope for Efficient Practical Remedy,' has been awarded to Dr. Ferdinand Tönnies, of Hamburg. A translation of the successful essay will appear in *Mind* shortly.

THE new cable between Brest and Cape Cod was completed on August 16th. This cable, 6,000 km. in length, is said to be the longest in the world and affords the most direct connection between Europe and America.

THE Marshall Museum of the University of Chicago is about to receive further valuable collections from the Egyptian excavations of Dr. Flinders Petrie and Mr. Quibell.

THE observatory established on Mount Blanc at an altitude of 4,400 m., by M. Vallot, is being moved to a position where the drifting snow will not interfere so seriously. The woodwork for the new building, which is larger and better arranged than its predecessor, is being carried up the mountain by some forty men, work having been begun on July 16th.

THE City of Hamburg has established a station for the protection of plants which has been placed under the direction of Dr. Brick, of the Hamburg Botanical Museum. It will be the duty of the station to supervise imported plants and to study diseases of plants, with special reference to their occurrence in the neighborhood of Hamburg.

THE Second International Sea Fisheries Congress met at Dieppe on August 3d, under the presidency of M. E. Perrier, professor of zoology at the Paris Museum of Natural History. After listening to an address by the President, the Congress was divided into four sections for the discussion of special topics, viz.: (1) Scientific researches, under the presidency of M. Mathias Duval, director of the fishery school at Boulogne; (2) fishery apparatus, preparation and transport, under the presidency of M. Delamare-Deboutville; (3) technical education, under the presidency of M. Jacques Le Seigneur, Commissioner of Marine at Granville; and (4) fishery regulations, under the presidency of M. Roché, Inspector-General of Fisheries. About

forty papers were presented before these sections, which were, however, in many cases of local rather than of international importance. The present, like the first Congress, was organized by the French Society for the Promotion of Technical Instruction in matters relating to Sea Fisheries, but an international committee has been named for the organization of future congresses.

THE Press Association states that Mr. Stanley Spencer and Dr. Berson ascended on September 5th from the Crystal Palace in a balloon inflated with pure hydrogen gas, and attained the remarkable altitude of 27,500 ft. Numerous scientific instruments, including a self-recording aneroid barometer, were carried, and compressed oxygen gas for inhaling at the greatest height. The descent was near Romford. It is expected that this will far surpass the results of simultaneous ascents at St. Petersburg, Moscow and Berlin, being only 1,500 ft. less than Coxwell and Glaisher's highest in 1862. The atmosphere was clear and the coast range visible. At 25,000 ft. the air became so rarefied that both explorers had to breathe compressed oxygen from tubes. The balloon had a capacity of 56,500 feet.

THE steamer *Antarctic*, with the members of the Swedish Arctic Expedition under Herr Nathorst, arrived at Tromsøe on September 7th. The expedition had thoroughly explored King Charles Land and circumnavigated West Spitzbergen and North-East Land.

MR. HERBERT SPENCER is about to issue the first volume of the revised and greatly enlarged edition of his 'Principles of Biology.'

PROFESSOR A. H. KEANE'S work on ethnology, dealing with fundamental ethnical problems and primary ethnical groups, will be followed by a volume entitled 'Man, Past and Present,' which will be issued by the Cambridge University Press.

MESSRS. C. ARTHUR PEARSON'S announcements for the autumn season include two books of travel. Captain Guy Burrows, of the Congo State military force, will, in 'The Land of the Pigmies,' describe his exploration of a region into which very few white men have ever penetrated. It is known as the district of the Upper



Uelle and lies to the north of the Aruwimi river. The pigmies, among whom Captain Burrows has lived, are a race about 4 feet in height; but, unlike all the other inhabitants of this region, they are not cannibals. 'Spinifex and Sand,' by the Hon. David Carnegie, will be a narrative of five years' pioneering and exploring in Western Australia, including a journey across the waterless deserts of the interior and through a vast territory that had not been previously explored.

THE foreign members of the Zoological Congress made an excursion, says the London *Times*, to the zoological institution which owes its existence to the enterprise and generosity of the Hon. L. Walter Rothschild. A party of over 150 members of the Congress travelled by special train to Tring, and drove from the station to the museum, over which they were conducted by Mr. Walter Rothschild, Mr. Charles Rothschild, Dr. Hartest and Dr. Jordan. The museum is still young and has grown rapidly from small beginnings. Mr. Rothschild when a boy began to make a collection of birds and insects. Owing to his expenditure of time and money the collection increased rapidly. A special house known as the 'Cottage' was built for it in 1889, to which a public exhibition gallery was subsequently added. The museum consists of two parts—a large hall containing a general zoological collection, and a series of private rooms containing the special collections, which are only available to students. The public gallery is packed with material, all of high quality, and much of it unique. The general collection is so rich that it is difficult to select objects for special mention, but the value of the material may be illustrated by reference to the unrivalled collection of the birds of paradise; to the specimens of the rare Caspian seal and the now extinct quagga; to the fossil birds from Chatham Island described by Mr. Andrews, and the unique monotreme from New Guinea (*Proechidna nigroaculeata*). Among specimens of more general interest may be mentioned the beautifully mounted Grevy's zebra, and the 'white' rhinoceros killed in Mashonaland by Mr. Rhodes's secretary, Mr. Coryndon, and the Chimpanzee 'Sally.' Although the exhibition gallery is full of specimens such as these,

the special study collections of birds and insects are the most important part of the museum. In spite of its recent foundation the museum contains some 40,000 bird skins, and the number of butterflies and beetles is reckoned by hundreds of thousands. Mr. Rothschild early realized the need for systematic work on zoogeography. The area to which he has devoted most attention is Malaysia, where he maintains a staff of collectors, who go from island to island and thus trace the distribution of the various elements in the Malaysian fauna with a precision less systematic efforts could never attain. The collections are sent to Tring. Since 1894 memoirs on the collections have been published in a special journal, the *Novitates Zoologicae*. Four complete volumes have been published. Attached to the museum is a paddock, where there is a collection of living animals.

SOME members of the Zoological Congress also visited Woburn to see the valuable collection of deer in the Abbey Park. To avoid disturbing the herds more than necessary, the Duke of Bedford's invitations were limited to about 50. The zoologists were met at Woburn by Mr. Lydekker, whose recent monograph, 'The Deer of all Lands,' is illustrated by numerous photographs of the Woburn herds, taken by the Duchess of Bedford. The deer there may be seen living under exceptionally favorable conditions. Many of the species, such as the elk and Père David's deer of northern China (*Elaphurus Davidianus*), are allowed to run at large about the open park; others, such as the small Indian muntjacs, live in the coverts. Those which cannot be allowed such liberty are confined in paddocks. The largest enclosure contains 150 acres, and is occupied by a herd of wapiti, sambar and bison. In a slightly smaller paddock are some Altaian wapiti, including the first living specimens brought to this country. The Indian spotted deer, or chital, share a third enclosure with some Virginian deer and Caspian red deer. Although the collection is of recent foundation it already includes 40 species, and the herds are much larger than can be seen in the Zoological Gardens. With the exception of a dredging expedition in connection with the Marine Biological

Laboratory at Plymouth, this excursion brought the Congress to a close.

IN the Irish Courts the Master of the Rolls recently delivered judgment, says the *British Medical Journal*, on a question brought before him in reference to the Carmichael Trusts. Application was made on behalf of the College of Surgeons that the existing scheme for the management and administration of the Carmichael Prize Fund, created by the will of the late Dr. Carmichael, might be altered, and a new scheme for the management of the fund should be settled by the Court. The late Dr. Carmichael, by his will of 1849, bequeathed to the College of Surgeons a sum of £3,000, and directed that the interest arising from this sum should be applied in giving every fourth year a premium of £200 for the best essay, and £100 for the second best essay on medical education; and he directed that the authors of such essays should make suggestions as to the improvement of the profession with a view to rendering it 'more useful to the public and a more respectable body than it is at present.' From time to time the College of Surgeons advertised in the public press for essays, but generally the essays submitted were deemed to be of insufficient merit, and no prizes were awarded. In 1866 the first prize was awarded to Dr. Mapother, and the second to Dr. Ashe. In 1879 the prizes were awarded to Mr. Rivington and Dr. Laffan, and in 1887 they were again awarded to the same two gentlemen. Since then no advertisements have been inserted for further prizes, the income of the fund being insufficient to pay for the printing of the 700 copies of each which were directed by the testator to be printed, and copies sent to Cabinet Ministers, heads of colleges, etc. The cost of printing each essay was on an average £100. One of the essays exhibited in court ran to 1,200 pages. The Council of the College of Surgeons were, it was stated, of opinion that the essays were doing no good, and they proposed that the income of the fund should be apportioned between the College of Surgeons and the Royal Medical Benevolent Fund Society of Ireland, the College of Surgeons to get three-fourths of the income, and the other body one-fourth, the Royal Medical Benevolent Society having been mentioned by the testator as

the body to get the £3,000 in the event of the College of Surgeons not carrying out the trusts named in the 'sequel.' The College of Surgeons proposed that their three-fourths of the income should be used in awarding every second year to a licentiate of the College a traveling prize of £100, in order to enable the successful candidate to visit hospitals in Vienna and other capitals on the Continent. Affidavits in support of the application were made by Sir Charles Cameron, Sir William Thomson, Sir William Stokes, Sir George Duffey, Sir William Thornley Stoker, Dr. Heuston, Dr. Jacob, Dr. Story and other leading members of the Colleges of Surgeons and Physicians. The Master of the Rolls said the original gift in this will had not in any legal sense at all failed, and, except as regarded the amount of money now available for the trust, it appeared to him quite possible to carry out the instructions of the testator, and he was of opinion that he had no power to devote the testator's money to a purpose which he did not contemplate or sanction. However, as the income of the fund was now insufficient to pay prizes of £200 and £100 every fourth year, including the large expenses of printing prize essays, and owing to the fact that the College has no fund to pay examiners of those essays, he thought some modification of the existing scheme was necessary. He would, therefore, refer the matter to chambers for an inquiry as to what alterations in the scheme were necessary to make it practicable and workable.

*Nature* quotes from the *Atti*, of the Reale Accademia dei Lincei, of Rome, the recent awards of prizes given by the King of Italy. For the Royal prize for mathematics eight competitors sent in no less than about ninety written and printed memoirs; and after a critical examination of these the judges have now divided the prize equally between Professor Corrade Segre and Professor Vito Volterra. The papers submitted appear to have been of a very high standard of excellence, and are stated to form a worthy sequel to the works of Betti, Brioschi and other illustrious Italian mathematicians. The award of the Royal prize for social and economic science has been deferred for a period of two years. A similar decision has been ar-

rived at in the case of the prize for astronomy, but a sum of 3,000 lire has been awarded to Professor Filippo Angelitti in consideration of his valuable work in editing and discussing the unpublished writings of Professor Carlo Brioschi. The prize for philology has been divided between Professor Angelo Solerti and Professor Remigio Sabbadini, and finally a Ministerial prize of 1,500 lire for natural science has been awarded to Professor L. Paolucci for his monograph on the fossil plants of the Ancona district. The Academy has recently elected the following associates and foreign members: National Associates—in physics, Professors A. Righi, A. Roiti, and A. Pacinotti; in geology and paleontology, Signore G. Scarbelli; in zoology, Professor C. Emery. Correspondent in mechanics, Professor C. Somigliana. Foreign Members—in mechanics, Professors A. G. Greenhill and V. Voigt; in physics, Professor W. C. Röntgen; in geology and paleontology Professor A. Karpinsky and Sir Archibald Geikie; in zoology, Professor E. Ray Lankester.

An ichthyosaurus 20 feet in length, the head two feet across, has, as we learn from *Nature*, recently been uncovered in the Warwickshire village of Stockton. The land is excavated by cement firms and has yielded many lower middle Lias fossils. The present specimen will, it is said, be presented to the Natural History Museum by the owner of the quarry.

#### UNIVERSITY AND EDUCATIONAL NEWS.

It is reported in the daily papers that Miss Jennie Flood has given to the University of California her Menlo Park mansion, together with five hundred and forty acres of land, and four-fifths of the stock of a waterworks plant which she owns.

The National Council of Education has authorized the appointment of a committee of fifteen to investigate the whole subject of the establishment of a national university and to report to the Council at its next meeting.

At Princeton University Mr. A. H. Phillips and Dr. E. O. Lovett have been appointed to assistant professorships in mineralogy and mathematics, respectively.

Mr. A. A. HELLER, instructor in botany in the University of Minnesota, has resigned his position to devote his time entirely to collecting. Professor Conway MacMillan may be addressed in reference to the Exchange Bureau.

THE State Department at Washington has received from Minister Conger at Pekin information that Dr. William A. P. Martin has been appointed President of the University of China, recently established by imperial decree. Dr. Martin was President of Pekin University for nearly thirty years. He is a citizen of the United States, but went to China as a missionary about forty years ago. Associated with Dr. Martin in the presidency is Hsu King Chang, now Minister to Russia. The selection of the corps of professors, some twenty, not including fifty native tutors, is left entirely to Dr. Martin.

Mr. E. G. COKER has been appointed assistant professor of engineering in McGill University.

DR. RUDOLF COHN, docent in physiological chemistry in the University of Königsberg, has been made professor. Dr. Zograf has been appointed assistant professor of zoology and Dr. Mrensblat assistant professor of comparative anatomy in the University of Moscow. Professor Hölder, of Königsberg, has been called to the chair of mathematics at Leipzig. Dr. Koetz has qualified as docent in chemistry in Göttingen and Dr. Smoluchowski von Smolen as docent in physics in Vienna. Dr. Adam Nell, professor of mathematics in the Darmstadt Technological Institute, has retired, having reached the age of seventy-four years.

PROFESSOR RIEDLER has presented to the engineering laboratory at Berlin machinery valued at \$30,000.

#### SCIENTIFIC LITERATURE.

*Nature Study in Elementary Schools.* By Mrs.

L. L. WILSON, Ph.D., Philadelphia Normal School for Girls. Pp. xix+262. Price, \$1.00. A *Reader* accompanying the same, pp. xv+181. New York, The Macmillan Company.

This 'Manual for Teachers,' the first of the books mentioned, is planned to meet the needs of the ordinary grade teachers in the first four years of the public schools of a city. In its scope it includes studies of the weather, of



plants and animals, brief notes on stones and the constellations, and an appendix giving illustrations of pupils' work in drawing and composition. The introduction deals somewhat with pedagogy, and touches upon the program, methods, materials, excursions and related work.

The book has a freshness that springs from the rich experience of a teacher who has enlisted heart and brain in the work of introducing children to the vast domain of nature. The choice of material shows a wise selection, and the presentation is, as it generally should be, from the standpoint of function. Since the nature experience of children is acquired from the landscape as a whole, it is a question whether the author does not descend too rapidly to details. It is important to treat the great nature image of the children in its wholeness by the constant presentation and re-presentation of the entire landscape from the varying standpoints afforded by its different aspects, caused by its daily, seasonal and other and more gradual changes. It is only by such broad presentation that the natural setting of the various elements in the landscape—the soil, the sunshine, the water, the plants, the animals, etc.—will be preserved in the child's mind. The suggestions concerning the study of the weather are the best illustrations of the evils of piecemeal presentation. To place the child 'in loving touch' with nature is the aim as expressed in the introduction; but the advantages of a study of the weather are later stated to be cheapness of material, cultivation of observation and reason, a basis for geography and the establishment of habits of neatness and accuracy—none of which have any tendency to increase the child's appreciation of what these forces have to do in making up his great nature picture. The subject is still further isolated; it is, in fact, completely side-tracked through the method proposed by the author to approach it 'through the myths.' There is no more natural or scientific reason why the child should approach the study of the weather through the myths than there is that he should approach the study of a horse through the story of that celebrated equine of ancient Troy. The myths are simply fantastic nonsense, except so far as the children

are able to interpret them in terms of what they themselves already have observed. The author of Cook's Myths, to which reference is made, by no means intends that her stories shall be used as an 'approach' to nature; on the contrary, in every case the study of nature has been made an *approach to the myths*. We must utterly despair of ever getting honest observation and direct, simple expression on the part of children as long as the teacher who guides them allows herself to be dominated or even influenced by the infatuation that she must provide a 'basis' for language, literature or any other related subject.

The material chosen for study has generally been selected with due regard to the season, but the author has disturbed this natural arrangement by suggesting the study of germination in January and the indoor observation of unfolding buds in March. It is scarcely necessary to undertake the uphill task of teaching germination in mid-winter in the face of every boisterous protest that nature can utter, when by bidding her time for a few weeks the teacher may receive the voluntary and cheerful assistance from the whole of sprouting creation. Buds are studied indoors that the eyes may be opened ready for the later developments outdoors. But, be it remembered, the real eye-opener is to see how the buds on the trees, environed by all the hazards of spring, gradually and safely unfurl the tender and delicate young leaves to the sunshine. With the proper presentation of outdoor nature in its season with children there is but little need of the usual devices for indoor study—certainly none whatever, unless called for to explain further something already observed under normal conditions.

The author is to be commended for her judgment and courage in the stand which she has taken regarding written expression, maintaining that but little is needed and that usually too much is demanded of children. She does not, however, give due weight to color work as a means of expression. For children, and for grown people too, the world exists mainly as a thing of color. The natural and easy mode of expression for this rich experience is by means of the brush. This form of expression is second to no other in scientific value. Excepting

motion alone, it is by color that the life condition is determined more clearly than by any other test. With less teaching than that given to any other mode of expression the pupils acquire amazing skill, not only in representations in color, but also in accurate expression of form.

The numerous selections from literature which the author has mentioned will be of great assistance to the busy teacher. They are well chosen and will enrich the study, provided they are not allowed to dominate the observation. They should be used only as the personal experience of the pupils with nature will warrant it.

The READER which the author has prepared as a companion book is composed of myths, stories and poems which are suggested more or less clearly by various natural phenomena. The selections are good, and in general the rendition is excellent. For this particular aspect of nature study, if such it may be considered, the book leaves but little to be desired.

The author seems inclined, however, to magnify the importance of the relation of the myth to science beyond what it deserves. If teachers follow the author's suggestions, that the stories be used to 'serve as an introduction to the science work,' the book will prove to be a veritable stumbling block for both teacher and pupil. Since the myths are assumed to be the outgrowth of direct observation of natural phenomena, and since they are regarded as fanciful and more or less poetical interpretations of the same, it is difficult to understand why anyone should wish to reverse this natural process of their development in teaching children. Nature has the right to ask that we bestow directly upon her at least one square look before we place her at the mercy of the freaks of fancy. If begun early enough, and continued with considerable fervor through the first three or four grades, this introduction of the child to nature through the mists of fable and tradition will be effective enough to forever refract his vision of creation. In the incipency of his experience with nature, there is no doubt that her large and somewhat terrifying aspects of cloud and storm and season seem surcharged with an almighty personality for which the

myths offer a sufficient description and interpretation. But the child quickly passes through this stage and is probably pretty well clear of it when he enters the primary grades. Thereafter, the myths are really nothing more to him than a *history* of how an exceedingly primitive interpretation has been given to natural phenomena, and they should be treated as such. The standpoint of the pupil, while none the less interesting, has totally changed.

The author advises that the stories first be told to the child, and, afterwards, that they read them. The purpose of the story, that it shall vivify the pupil's own experience, will probably be best accomplished by the teachers' narration, and there seems to be no valid reason why the pupils at this time should be required to read them, especially if the teacher should find it necessary to 'thoroughly drill' upon all the new words. There is no surer way to spoil the effect of the story than by doing this. That silent reading, as suggested, should be encouraged is unquestionably true.

The considerable array of material which these books provide from both the scientific and the literary side will make them valuable for any teacher in the public schools, while the author's earnestness of purpose, strongly manifest throughout the work, will prove to be a lasting source of inspiration.

WILBUR S. JACKMAN.

CHICAGO NORMAL SCHOOL.

---

#### NEW BOOKS.

- Commercial Organic Analysis.* ALFRED H. ALLEN. Third Edition with Revisions and addenda by the author and HENRY LEFFMANN. Philadelphia, Pa., P. Blakiston, Son & Co. 1898. Vol. I. Pp. xii + 557. \$4.50.
- A Short Manual of Analytical Chemistry.* JOHN MUTER. Philadelphia, Pa., P. Blakiston, Son & Co. 1898. 3d American Edition. Pp. xiii + 228. \$1.25.
- Zoological Results.* Based on material from New Britain, New Guinea, Loyalty Islands and elsewhere, collected during the years 1895, 1896, 1897. ARTHUR WILLEY. Cambridge, The University Press. 1898. Part I. Pp. vi + 120.

# SCIENCE

EDITORIAL COMMITTEE: S. NEWCOMB, Mathematics; R. S. WOODWARD, Mechanics; E. C. PICKERING, Astronomy; T. C. MENDENHALL, Physics; R. H. THURSTON, Engineering; IRA REMSEN, Chemistry; J. LE CONTE, Geology; W. M. DAVIS, Physiography; O. C. MARSH, Paleontology; W. K. BROOKS, C. HART MERRIAM, Zoology; S. H. SCUDDER, Entomology; C. E. BESSEY, N. L. BRITTON, Botany; HENRY F. OSBORN, General Biology; C. S. MINOT, Embryology, Histology; H. P. BOWDITCH, Physiology; J. S. BILLINGS, Hygiene; J. MCKEEN CATTELL, Psychology; DANIEL G. BRINTON, J. W. POWELL, Anthropology.

FRIDAY, OCTOBER 7, 1898.

## CONTENTS:

<i>The Harvard Astrophysical Conference: PROFESSOR M. B. SNYDER.....</i>	449
<i>Geology and Geography at the American Association Meeting, I.: WARREN UPHAM.....</i>	462
<i>The Botanical Society of America.....</i>	471
<i>Meeting of the American Forestry Association at Boston.....</i>	471
<i>Notes on Physics:—</i>	
<i>Gay Lussac's Law and Atmospheric Nitrogen; Liquid Ammonia; Measurement of the Intensity of Sound: W. S. F.....</i>	472
<i>Notes on Inorganic Chemistry: J. L. H.....</i>	473
<i>Zoological Notes: F. A. LUCAS.....</i>	474
<i>Current Notes on Anthropology:—</i>	
<i>The Zoque Language; The Anthropology of Brunswick; The Querandies: PROFESSOR D. G. BRINTON.....</i>	474
<i>Scientific Notes and News.....</i>	475
<i>University and Educational News.....</i>	478
<i>Discussion and Correspondence:—</i>	
<i>The Windmill Illusion: A. H. PIERCE, PROFESSOR JOSEPH LE CONTE.....</i>	479
<i>Scientific Literature:—</i>	
<i>Conant on the Cubomedusæ: PROFESSOR H. V. WILSON.....</i>	481
<i>Scientific Journals.....</i>	484
<i>New Books.....</i>	484

MSS. intended for publication and books, etc., intended for review should be sent to the responsible editor, Professor J. McKeen Cattell, Garrison-on-Hudson, N. Y.

## THE HARVARD ASTROPHYSICAL CONFERENCE.

THE first Astrophysical Conference, held on the memorable occasion of the dedication of the Yerkes Observatory, was so marked a success and started a movement so important to American astrophysical

science that it was to be expected it would result in the perpetuation of such conferences. Both from the graceful tribute brought on that occasion from Harvard, the oldest observatory devoted to astrophysical research, to the newest seeking similar work, and from the fact that Professor E. C. Pickering's fearless application of modern methods of research to far-reaching astronomical problems had made the Harvard Observatory a center of interest to many astronomers, was it eminently proper that the second Conference, and that first proposing a permanent organization of American astronomers, should be held at the Harvard College Observatory.

Quite apart from the scientific papers read and discussed, the Observatory entertaining the Conference in itself constituted a special contribution. In no other observatory could the methods by which modern astronomy is breaking with traditional types of work be more completely and systematically exhibited. Professor E. C. Pickering's vast organization of work, as concretely represented in the photographic and other results accessible to the members of the Conference, was unquestionably the greatest and most inspiring contribution made to the Conference. There were the organized photometric determinations represented not only in Professor Pickering's own work with the meridian photometer, but in the work of Mr. Wendell in accurate



photometric measurements of variable stars, and in the other general photometry systematically carried on by a number of observers. In the photographic enterprises there was the charting of the stars of the entire heavens once every year by means of the eight-inch Bache and Draper photographic doublets and smaller instruments, and the photographic study of the Milky Way on different scales by exposure of four or five hours with the two and one-half inch, eight inch and twenty-four inch Bruce telescopes.

Photographic spectroscopy was represented by a general spectroscopic *Durchmusterung* carried out by an eight-inch telescope provided with an objective prism. For details of the spectra of the brighter stars there were present photographic spectra given by the eleven-inch photographic telescope of the Harvard Observatory and the thirteen-inch at Arequipa, taken with from one to four objective prisms. And for the spectra of very faint objects the twenty-four-inch Bruce, armed with its objective prisms, presented minute details. Among the list of notable discoveries due to these organized methods of research of Professor Pickering there were shown the spectra of the invisible binaries, the spectra of numerous bright line variable stars, the results of study on stars having peculiar spectra, and in the wonderful photographs of clusters, of definition probably surpassing any yet made, were disclosed those hundreds of variable stars in which Professors Pickering and Bailey have just reason to express a proud delight.

Whether the members of the Conference were instructed in shrewd management of stellar photography by Mr. King, or listened to the detailed explanation of the methods of examining photographic spectra by Mrs. Fleming or Miss Maury, with the vast library of plates at their command, or followed Professor Bailey in his most interesting charting of the periods of hun-

dreds of variables in the star clusters, or discussed with Professor Searle the methods by which he is bringing to completion the *Gesellschaft* zone, or reviewed with Professor W. H. Pickering problems in direct telescopic observations, or with Mr. Wendell they followed the highly accurate measurements of stellar magnitude at the equatorial, or whether with any one of the other observers they undertook to follow the work, not omitting the special work with the meridian photometer in which Professor Pickering himself so actively participates, one could not help feeling the presence of a genius for organization and for the determinate solution of vast scientific problems which alike instructed and inspired. It would, therefore, be but just to record the enthusiastic appreciation of the Conference for the contribution which the Director of the Observatory of Harvard College incidentally presented.

Upon organization of the Conference Professor Pickering briefly welcomed the Conference to the hospitality and inspection of the Observatory. The list of papers and their discussion was then immediately begun.

The Conference was presided over alternately by Professor J. R. Eastman, of the United States Naval Observatory, and Professor George E. Hale, Director of the Yerkes Observatory, and the meetings were not only held during the allotted time, August 18th, 19th and 20th, but were carried over to a series of adjourned meetings held during the course of the subsequent week.

Professor Arthur Searle presented his experience on 'Personal Equation in Transit Observations.' He showed that in two observers' work there was a difference in (1) the term  $\Delta T + m$ , the ordinary personal equation; (2) the collimation microscopically determined and computed from transits; (3) the apparent position of the

instrument, the axis being more inclined to the plane of the equator for one observer than for another; (4) the apparent rate of clock during the evening, due probably to increasing fatigue; (5) that due to magnitude of stars. Professor Searle pointed out a collimation effect on transits due to bad focus of eyepiece, the lines being displaced by reflected light in illumination. This was shown optically and by a series of transits by two observers, Professor Searle and his assistant, Mr. J. A. Dunne, using different foci of eyepiece.

In the discussion Professor W. H. Pickering suggested that the doubling of wires noticed in the transit instrument under false focusing was analogous to the doubling of the lines of Mars, and that the latter phenomenon was probably due to false focus, and hence doubling of the image in the human eye. Professor Comstock stated that there is a law of variation of personal equation with the declination, but that there is also a variation due to physical condition. When the observer is tired, observations are made more quickly. Professor Eastman said that he had found that malarial fever brought down the personal equation as much as half a second earlier and that there was also a diurnal variation in the personal equation. Mr. Hayford stated that the experience of the United States Coast Survey indicated that personal equation was not appreciably affected by using different forms of signal keys.

Professor George C. Comstock presented 'Some Investigations Relating to Zenith Telescope Latitudes.' In the course of a determination of the constant of aberration it was found that two causes of error entered. In the first place, it was noted that any local temperature changes of the atmosphere unsymmetrical with respect to the instrument had a very serious influence on the apparent variation of the latitude. In the second place, general variation in the

atmospheric refraction was not eliminated. The atmospheric layers are not normal to the vertical, and the barometric and thermometric gradients vary irregularly. The zenith telescope gave a constant of aberration varying from  $20''.38$  to  $20''.64$ , with a range of  $0''.26$ , while even the carefully determined values of Preston,  $20''.43$ , and Gill,  $20''.58$ , gave a range of  $0''.15$ . At least a partial explanation of these variations may be found in the local conditions surrounding the various observatories. Comparing the values derived at New York,  $20''.46$ , with that of Naples,  $20''.53$ , the difference is found to be such as may be accounted for by the diurnal temperature changes accompanying the changing land and sea breezes of the respective places. The large value,  $20''.58$ , obtained at the Cape of Good Hope by Gill is capable of similar explanation, and no case has been found that violates this hypothesis. The result is that the local conditions of every place affect the determination of the aberration constant, and in such investigations it becomes advisable to abandon the zenith telescope and all other instruments which depend upon the vertical as a reference line.

Professor Doolittle stated that he had called attention to the outstanding variations in latitude determinations and believed the cause to be a variation in the refraction. The deviation is a good many times as great as the probable error of the observations. The limit of accuracy of the zenith telescope method has been reached.

Doctor Harold Jacoby presented a paper on 'Photographic Researches near the Pole of the Heavens.' The object of the research is to furnish new values of the fundamental constants of stellar astronomy. The plan consists in making exposures for short trails around the pole, like those first made at the Harvard College Observatory. The records on the plates being made apart from either clock or graduated circle fur-

nish an independent method. The particular negatives used were made at Helsingfors by Professor Anders Donner, and the northerly latitude reduces distortion occasioned by refraction to a minimum. Formulæ suitable for the complete reduction of ordinary polar plates star photographs as well as for the special plates described have been deduced and an application made to measures on one plate of six images of each of ten stars, with encouraging results. A discussion was undertaken, assuming first that the instrument remained fixed during the exposure, and second that it was in motion. Making the reductions according to the latter hypothesis the results are in accord with the best north polar distance determinations of Auwers. The line of motion was vertical, by sagging. All the images on two Helsingfors plates, made six months apart, will be measured and the results treated for a general test of the possibilities of the method. The work already accomplished will soon be published in full detail.

Professor Pickering said that aberration and nutation could be thus best determined, and that the 15-inch Draper telescope has for several years been photographing the pole every clear night with automatic exposure, the plate in some cases hanging vertical so as to eliminate one equation of condition. Professor Paul held that lateral and vertical refraction might enter as disturbing factors. Professor Comstock, while agreeing with Professor Paul as to the possibility of refraction variations, held it to be highly desirable that Doctor Jacoby should prosecute his researches. Doctor Jacoby remarked that a new method like this should be received with scepticism and that the test of this plan would be by thorough work extending perhaps over one generation.

Mrs. M. Fleming's paper on the 'Stars of the 5th Type in the Magellanic Clouds' was presented by Professor E. C. Pickering.

Stars having spectra consisting mainly of bright lines belong to Type V. In 1891 the number of these stars known was thirty-three. Three of these were discovered by Wolff and Rayet, one by Respighi, six by Copeland, three by Pickering and twenty from the Draper Memorial Photographs of the Harvard College Observatory. In May, 1897, the number known was sixty-seven. All of these stars lie closely along the central line of the Milky Way, and, although the sky had been equally well covered with spectrum plates from pole to pole, a careful examination of the plates failed to show any of these stars outside of this region.

On May 26, 1897, an examination of two photographs taken at Arequipa with the Bruce telescope showed a group of six of these objects in the Large Magellanic Cloud. Two later plates add fifteen more, and these with three other stars in the Milky Way, and one in the Small Magellanic Cloud, make the total number of these stars, so far known, ninety-two. Thirteen of these were found visually; all the others have been found by Mrs. Fleming from Draper Memorial photographs. The great advantages of photography in the study of stellar spectra is thus again demonstrated.

The presence of so many stars of the Fifth Type in the Magellanic Cloud establishes another connection between this object and the Milky Way.

Professor Solon I. Bailey presented a paper on 'Variable Stars in Clusters.' A systematic examination of twenty of the most interesting, dense, globular clusters has been made. In these clusters 18,600 stars were compared, of which 501 were found to be variable. In only a few of these clusters does the percentage of variables amount to more than one per cent., and in many cases it is less. A few clusters, however, give remarkable results. The most striking is Messier 3, where 132 stars out of a total of 900 are variable, or one in seven. Other



clusters remarkable for the number of variables are Messier 5, Omega Centauri and Messier 15. These four clusters together have 393 variables. At the present time the periods and light curves of more than one hundred have been determined. These periods are generally less than 24 hours, and are characterized by an abrupt increase in light and a slower decrease. These results have all been obtained by photography. They would have been impossible with instruments of the same size by visual methods. The photographs were made with a 13" telescope. The faintest variables are quite invisible in the same telescope, and it is doubtful if they can be well studied visually in a telescope of less than 30" or 40" aperture. The shortest period of these variables is 6<sup>h</sup> 11<sup>m</sup>, which makes it the shortest period known.

Professor Bailey's remarkable work was rendered extremely interesting by the exhibition of some of the original photographs and of the numerous charts of the change in brightness of these variables which he had been able to prepare. Professor E. E. Barnard stated that he was surprised that this great discovery had attracted so little attention. He knew the photographic plate could be depended on. The great Yerkes telescope very readily verified the periods. He had verified three of Professor Bailey's periods, but was afraid the visual was inferior to the photographic method. Father Hagen stated that the stars were on the limit of visibility in the 12-inch telescope, and there seemed to be no charts of these clusters. Professor Pickering stated that photographic charts of the clusters would be furnished by the Harvard College Observatory.

Mr. Albert S. Flint, in a contribution on 'Meridian Observations for Stellar Parallax,' presented a summary of the results of the observations for stellar parallax, made at the Washburn Observatory, on a list of

nearly one hundred stars. The method employed is that of differences of meridian transits. The value of the method is confirmed by the good agreement with other accurate determinations of stellar parallax and by the absence of any plainly indicated systematic errors. The first comparison gave an average difference of only 0".03 on the fifty stars elsewhere observed. The probable error of the definitive parallax for any one star varies from 0".030 to 0".040, except for great zenith distances. The values depend upon from forty to sixty observations extended through from four to six epochs. A new series of similar observations has been begun, which will include second-magnitude stars and binaries. The new Repsold transit micrometer will be employed, with which the observer maintains bisection with a movable thread, while the chronograph signals are made automatically by the revolving micrometer head.

Professor Comstock said that while the average accuracy of the method is not as great as with the heliometer or by photography more observations can be made and gross error eliminated. The method is useful for a general parallax survey.

Professor Charles Lane Poor, in a paper on 'The Direct Grating Spectroscope and its Applications to Stellar Photography,' stated that already in 1891 and 1892 he had experimented with the direct vision grating in photographing star spectra, and had taken the problem up afresh in the fall of 1897, using both a 2-inch grating and a specially ruled grating of 6.5 inches aperture and 39 inches radius of curvature. Properly mounted on a guiding telescope good photographs of stars to fourth magnitude resulted. Many of these were exhibited by Dr. Poor. Aside from the advantage of securing normal spectra, the method permits the determination of the relative wave-length shift by photograph-

ing two stars on same plate. Dr. George E. Hale stated that a machine, intended to rule gratings 9 inches by 15 inches, was now being built at the Yerkes Observatory. The great difficulties attending ruling of surfaces of sharp curvature were described by Dr. Poor.

In discussing the methods of producing normal spectra of stars, Mr. Edward S. King stated that at the Harvard College Observatory two methods of transforming the prismatic into the normal spectrum had been tried with success. In the first, photographs were taken of the original plate through a slit with the plates moving at differential rates. In the second method the plates are inclined to the axis of the lens, so as to make the scale exact for three points of it while maintaining good focus. The first method is applicable for producing any unequal change of scale. The second, though of an approximate character, is the better working method. Mr. King showed admirable photographic comparisons of star spectra with Rowland's map.

Professor E. C. Pickering added that the method just described was thoroughly general and that all scales were thus reproducible. He believed that the Orion lines could be well investigated by a grating, as suggested by Dr. Poor.

Professor G. W. Hough discussed 'The Effect of Atmospheric Disturbance on Telescopic Definition.' The local atmospheric disturbances should be differentiated from the general atmospheric conditions. As the object-glass of the largest telescope is infinitely small compared to the size of the atmospheric waves the disturbance will vary directly with the magnifying power. When a disturbance is just in front of the instrument there is displacement and distortion as well. Capping the object-glass usually produces no improvement.

Professor W. H. Pickering said the local

conditions at Arequipa are satisfactory. Caps make little difference with large telescope, but with 6-inch telescope, or less, caps are valuable. Double stars are not the best test of seeing, but rather detail work on planets. Professor Hale said small telescopes are not as good in fair seeing as big ones for any work. There are many false statements on this point. The two faults of seeing are jumping and blurs. At Flagstaff there is a lively jumping. The highest power used at Yerkes is from 2,500 to 3,000.

Miss Agnes M. Clerke's paper 'On the Spectra on Certain Nebulæ,' read in the author's absence by Professor Snyder, called attention to the demand for a special study of the spectra of white nebulæ, by reason of the nature of their structure, their mode of distribution in the heavens, and the quality of their light differentiating them from the gaseous nebulæ. Miss Clerke proposed 30 Doradûs, whose spectrum Professor E. C. Pickering had described as 'partly stellar and partly gaseous;' Messier 1, of which Pierce and Winlock, and later Campbell, had made interesting observations, and N. G. C. 6299 as examples of this anomalous class. Professor E. C. Pickering, exhibited several recent photographs of spectra of the nebulæ indicated by Miss Clerke.

Mr. J. F. Hayford, in speaking of a 'Proposed Publication of the Coast and Geodetic Survey,' said that the Coast and Geodetic Survey proposes to publish in the form of a catalogue of north polar distances the computed data which it now has in its possession. The catalogue will comprise stars which have been observed for latitude in the survey. The number of stars, 6th magnitude and brighter, comprised in the catalogue will be about 3,500. The degree of accuracy pertaining to each polar distance and proper motion will be indicated by attached probable errors. The systematic corrections and weights assigned in

the computations to each catalogue are substantially those assigned by Professor Lewis Boss in his report on similar work for the Northwest Boundary Survey in the seventies.

Professor Pickering presented a paper by Mrs. M. Fleming on the 'Classification of the Spectra of Variable Stars of Long Period.' In the classification of the spectra of stars in the Draper Catalogue the letter M was assigned to stars having spectra of the third type. Later these stars were subdivided into four groups, Ma, Mb, Mc and Md, of which  $\alpha$  Orionis,  $\alpha$  Herculis,  $-2^{\circ}3653$ , and  $\alpha$  Ceti were given as examples. In the last of these stars the hydrogen lines are bright, and this spectrum has been shown to be characteristic of variable stars of long period; indeed, by this peculiarity in the spectrum about a hundred new variable stars have been found. A further examination of these spectra shows that they can be further subdivided into eleven groups. A classification made from an examination of the continuous spectrum, the comparative brightness of the hydrogen lines being also carefully estimated, always assuming the brightness of  $H\gamma$  as 10, the first class, of which R Lyncis is a typical star, showed a spectrum resembling  $\alpha$  Tauri, and having  $H\beta$  and  $H\gamma$  strongly bright, and nearly equal, while  $H\delta$  was barely visible. The last group, of which R Leonis is a typical star, shows a continuous spectrum like  $-2^{\circ}3653$  with  $H\beta$  invisible,  $H\gamma$  barely visible and  $H\delta$  strongly marked.

The original photographs were exhibited and examined by the Conference.

Professor G. W. Myers presented 'A Study of the Light Variation of U Pegasi.' The hypotheses assumed were: (1) The light curve given by Pickering in Harvard College Observatory Circular No. 23 represents the true nature of the light change of this star near enough to determine provisional orbital elements, and (2) The light change is capable of explanation on the sat-

ellite theory. After the discussion showed the desirability of introducing a flattening, the further assumption was made: (3) The two components are deformed by tidal influence into similar ellipsoids of revolution.

Equations were then derived connecting the light curve with the 'elements' defining the system whereby the latter might be derived from the former, and *vice versa*. From these equations the following results were obtained: The light curve of U Pegasi, given in circular No. 23, is satisfactorily represented by the satellite theory with a circular orbit, whose radius differs but slightly from the sum of the major axes of the components, and whose inclination is very nearly 90 degrees. The smaller component has a brightness of about 0.77, and a radius of 0.78 of the larger, while a slight flattening of the disks probably exists. Accuracy of present observations does not warrant a least square adjustment of the outstanding residuals. There is some reason to believe in the existence in this system of the apoidal form of Poincaré.

Professor E. C. Pickering said it was astonishing how slight were the differences between observed and theoretical values of the brightness, and this agreement was confirmatory both of the observations and the theory. Mr. H. M. Parkhurst could not accept the period assumed, and questioned the accuracy of determinations of minima differing by but .15 of a magnitude. Professor M. B. Snyder held that the relation of Professor Myers' present work to that of Doctor See on the evolution of binaries was quite remarkable, and, seeing that Doctor See's prediction of variation of eccentricity was just what Doctor Myers had required as an hypothesis in treating the similar variable  $\beta$  Lyræ, the results were anything but discouraging to all the hypotheses involved in their interesting work.

Professor George E. Hale, exhibiting a set of remarkable photographs, presented a



review of work on 'The Spectra of Stars of Secchi's Fourth Type.' The spectra of 22 stars of this type have been photographed with the 40-inch Yerkes telescope, in most cases with a dispersion of one prism. For the stars Schjellerup 132 and 152, which are the brightest specimens of this type, the three-prism spectrograph was also employed. The photographs all show a large number of lines hitherto unrecorded. Most of these are dark, but there seem to be a certain number of bright lines. These show best with high dispersion, and are not weakened in intensity by widening the slit. The brighter ones have been observed visually, in Schjellerup 132 and 152, using a dispersion of three prisms. At Dr. Hale's request the spectrum of Schjellerup 152 was observed visually with the 36-inch telescope of the Lick Observatory by Professors Keeler and Campbell, who concluded that bright lines were almost certainly present. Further tests of these lines are being made at the Yerkes Observatory. The wave-lengths of two of the brightest of these lines agree very closely with the wave-lengths of two of the brightest lines in the spectra of the Wolf-Rayet stars, as measured by Professor Campbell. It is still too early to conclude, however, that any connection exists between the stars of the fourth type and those of the Wolf-Rayet class. In this connection it should be remarked that the fourth-type stars, as plotted by Mr. J. A. Parkhurst at the Yerkes Observatory, show a much stronger tendency to cluster in and near the Milky Way than any other stars except those of the Wolf-Rayet type. It has been found possible to arrange the spectra of eleven fourth-type stars in a series, having at one end the star DM 59° 2810 and at the other Schjellerup 155b. The investigation, which is being made with the assistance of M. F. Ellerman and Doctor Schlesinger, will be continued during the coming year.

Professor E. E. Barnard exhibited a series of photographs illustrating the work that had been done with the 6-inch aperture lens. These consisted of photographs of various portions of the Milky Way, showing its cloud forms and intricate structure. Many singular peculiarities were shown, such as the great rifts where the Milky Way appears to be rent asunder as if it were breaking up. The impression is that certain portions of the Milky Way consisted of sheets of stars of comparatively little depth, and it is in such regions that the process of disintegration seems to be going on. In some of the great clouds of stars are shown very distinct black holes, in the densest portions, as though tunnels perforated through the cloud masses and permitted one to look into the blackness of space beyond. Another striking feature is the presence of vacant lanes or black channels among the stars of the Milky Way. In these no stars seem to exist. Still another feature is the strange geometrical arrangement of the stars in curves in certain regions, as if some force were at work in this structural arrangement, baffling for the present direct explanation. One of the most extraordinary features is the presence of vast regions of faint diffused nebulosity, mixing up with the stars of the Milky Way. This nebulosity is better dealt with by the photographic plate, because it is too faint to affect the human eye. It is suggested that when this remarkable feature comes to be thoroughly studied, it will doubtless lead to a better understanding of the physical condition of the Milky Way and of its origin.

The photographs of comets, especially of Brooks' of 1893, show most remarkable and rapid changes in the form and structure of the tail. It seemed to suggest that the tail may have encountered some resistance in its flight through space. Comets are perhaps the only objects that would be able to

point out such streams of resistance. It is possible that the tail of this comet swept over a meteor stream or some other less resisting medium in space on the 20th, 21st and 22d of October, 1893. Portions of the tail seemed to have been torn off and to be drifting away from the comet as independent masses, and, if our ideas of comets are correct, these might themselves become swarms of meteors.

The series of photographs shown indicated the valuable results attained and the wide field of study opened by this method of research.

Mr. A. Lawrence Rotch gave 'A Brief Account of the Work of the Blue Hill Meteorological Observatory,' in which he described the peculiar instruments used, and adverted to the scientific character of the work carried on. His account was accompanied by photographs of the instruments, and on closing the description he invited the Conference to an inspection of the Observatory, which was cordially accepted and participated in by many of the members. Those who visited the Blue Hill Observatory were greatly impressed with the methods and appliances used in the difficult problems of meteorological research there attempted.

Miss A. C. Maury read a paper on 'The K Lines of  $\beta$  Aurigæ.' She said  $\beta$  Aurigæ is a double star whose components revolve in a period of  $3^d 23^h 37^m$  approximately, and with a velocity in the line of sight of 150 miles a second. As the distance between their centers, supposing the plane of the orbit to pass through the sun, is only about eight million miles, the stars are, of course, inseparable by the telescope, but their spectra become separated when, in the course of revolution, one star is approaching the earth and the other receding from it. By the Doppler principle, all the lines of the combined spectrum then appear double, those of the star approaching being

shifted toward the violet, those of the star receding, toward the red.

Photographs of the double spectrum, two hundred in number, obtained at the Harvard Observatory during the past nine years, show that the K line (of calcium) varies periodically in intensity. It is stronger in one star in the photographs of one year and in the other star in those of the year following, the relative intensity thus alternating for nine years. This variation, though less perceptible, may extend to other lines of the spectrum. It seems probable that the revolving stars, which are nearly or quite alike in mass and constitution, induce in one another reciprocal variability.

A similar variation has been suspected by Professor S. I. Bailey in the components of the Spectroscopic binary  $\mu'$  Scorpii, as shown in the Photographs obtained in Peru.

Professor Winslow Upton presented the methods of determining 'The Position of the Arequipa Station of the Harvard College Observatory.' The latitude of the Arequipa station was obtained by observations in the prime vertical made with a special instrument designed by the late Professor William A. Rogers. The observations were made by two Besselian methods, the extreme range for individual observations being  $7''$ . The final value for the latitude is  $-16^\circ 22' 28''.0 \pm 0''.19$ . The longitude was obtained by telegraphic exchange of time signals between Arequipa and Arica, Chile, the longitude of the latter station having been determined in 1883 by officers in the United States Navy by means of the coast cables. The difficulties of making the exchange directly made it necessary to repeat the signals in passing from the land telegraph line to the cable. The difference of longitude was determined with a probable error of  $\pm 0''.032$ , and the resulting longitude is  $4^h 46^m 11''.71$  west of Greenwich.

Mr. Henry M. Parkhurst, in a paper on

'The Rotation of the Asteroids,' discussed his photometric observations, extending over a number of years, on planets Nos. 40 and 42, and from these observations concludes that no hypothesis of rotation need be introduced to account for any changes in brightness.

Dr. Herman S. Davis presented a paper, read by Professor Upton, on 'The Parallaxes of 61 and 62 Cygni and the Probable Physical Connection of these two Stars.' From a review of the observed photographic results of parallax and the apparent difference in parallax of the two stars, the author concludes that 'these two stars are moving through space independently of each other and separated from each other by an interval represented by two and one-quarter light years;' but does not 'regard this difference of parallax as an entirely indisputable fact.' He, however, insists that the two stars of 61 Cygni should be regarded as too remote from each other to form a binary system until more evidence is adduced to disprove this conclusion.

Professor Comstock said he was of the opinion that the stars were at some distance; considering the difference of parallax  $0''.08$ , Dr. Davis' is not the only hypothesis allowable. A more plausible hypothesis is that one of these stars is accompanied by a dark companion, about which the star revolves so as to counteract the motion of the earth. The *a priori* probability in both hypotheses is perhaps the same. Professor Frisby thought that the parallax determination showed overlapping values not consistent with Dr. Davis' hypothesis. Professor Flint pointed to the large range of variation in the parallax determinations of these two stars and thought Dr. Davis' hypothesis unwarranted.

Professor Charles L. Doolittle reviewed the 'Work of the Flower Observatory.' Double-star observations made by Mr. Eric Doolittle, on a list prepared by Mr. Burn-

ham, have been made with the 18-inch telescope of Mr. Brashear. The difficult pairs observed are a fair test of the performance of the instrument. The theoretical power of separation is  $0''.275$  and yet in one case a pair separated by  $0''.24$  has been measured. Comparing the work of the Brashear instrument with similar observations made by Mr. Burnham with the Clark instrument of approximately the same aperture at Evanston, it is found that the Brashear instrument will resolve all pairs shown by the Clark. Fourteen pairs of new doubles have been picked up, and this indicates that an ample harvest is yet to be reaped. Four hundred and fifty pairs have been measured on three different evenings, and the results will soon be published. Professor Hough thought the results had certainly shown the Brashear objective to be a good one.

A paper by Professor Arthur Searle on 'Faint Stellar Bands in the Ecliptic' was read by Mr. William Maxwell Reed. If faint stellar bands exist in the ecliptic the observed shape of the *Gegenschein* would certainly be affected. Such bands Professor Searle has observed. The most prominent of these extends from Aquila through Aquarius and Pisces to the neighborhood of  $\gamma$  Tauri. Another falls close to the ecliptic. It commences in Gemini and ends in Coma Berenices. These bands seem to be a part of a network, of faint bands that cover nearly the whole sky. The *Gegenschein* is not always perfectly round.

Professor S. I. Bailey, in discussing this paper, said that in his observation of the *Gegenschein* in Chile and Arequipa he had never been able to see the *Gegenschein* perfectly circular. He suggests that the faint bands might be photographed, and thus their character and brightness better determined. He had, however, not been able to photograph the zodiacal light. Drawings of the bands as made independently both



by Professor Searle and Mr. Reed were exhibited, and, considering the delicacy of the observations, coincided well.

Professor Frank W. Very, in a paper on 'The Probable Range of Temperature on the Moon,' described his experimental work in determining the radiation from diverse substances at ordinary temperatures. Special attention was called to the compensation involved in radiation from subsurface molecules, which narrows the range of radiant emissivity, as exercised by different materials. Hence, the errors committed in classifying radiators in a very few, or, under certain restrictions, even in a single division, are not large. Measurements of lunar radiation have been carefully made at various phases, and the interpretation of these results in terms of absolute measurement is now possible. The method of reduction was indicated, and the final conclusion was that the moon's surface temperature lags behind the possible temperature which might be given by the sun's rays throughout most of the seven days of the lunar morning. A retention of heat by the surface material of the moon is thus shown; but the retention is so small that almost the whole of the heat received while the sun is above the horizon is lost before sundown on the same day, and thus the proper radiation from the surface, which in the case of the earth goes out to an entire circumscribing sphere, emanates virtually from only half the surface of the moon while it is undergoing insulation. The day temperature of the moon consequently becomes extremely high—above that of boiling water, except in the polar regions—while at night the cold approaches that of space.

Professor William H. Pickering presented a paper (not read) on 'Swift's Comet I., 1892.' This comet, discovered March 6th, was first noticed to have a faint tail, by Finley, on March 26th. As discov-

ered at Arequipa, March 29th, the tail was well developed. Forty-four photographs were taken of this comet and used in a recent investigation of its nature. The tail was plainly two-fold in character, the inner tail continuously issuing from the head, and, being at least 20 degrees in length a month after passing perihelion, consisted of two absolutely straight rays inclined at an angle of 10 degrees. The outer tail was formed by successive eruptions from the head, later diminishing in angle. The whole effect was to produce multiple tails like the comet of 1744. The photographs showed the inner tail to be of a different character on alternate days, now appearing continuous near the head and now bifurcated. The explanation is that the comet rotates about a longitudinal axis directed toward the sun, the rotation period determined being 94.4 hours. This period was determined by the use of the photographs made at Arequipa by the writer, and corrected by those of Professors Barnard and Wolf. Bessel observed in Halley's comet, in 1835, 'a vibration from side to side' with a period of 110 hours; this was probably a similar rotation of the comet with an analogous period. The changing appearance of both comets being explicable by the hypothesis of rotation, the next endeavor was to find a physical explanation of the cause of such rotation. The sun furnishes a strong electro-magnetic field. The comet also by the electrical induction of the sun receives electrical charges, and these charges are, by the gases of the tails, radially projected from the head of the comet, and become in effect so many electrical currents. The result of the motion of these radiating currents, *i. e.*, tails, in the magnetic field of the sun is the production of a spinning of the comet about a longitudinal axis. Theory would thus produce the rotation demanded by observation, and the rotation would be independent of the direction of the motion of the comet,

but north of the solar equator the rotational force is in one direction, and south of it in the other.

It is generally impossible to indicate a point in the tail of the comet; the exception occurs on the plates of April 5, 6, 7, 8 and 10, where a bright detailed structure is receding with increasing velocity of from one million to twenty-five million kilometers per day. The velocity of recession is 36 times the acceleration of gravity, and does not agree with any of the velocities required by Bredichin's hypothesis. The spectrum, as given by an objective prism, of the head and tail showed five bands probably due to hydrocarbons. A further test of the theory of axial rotation of comets near the sun would be an observed change of direction or speed of rotation in the solar magnetic field. Another would be the observation of the rotation when the tail is directed approximately toward the observer.

Professor Edward C. Pickering presented to the Conference a letter he had received from Professor H. H. Turner, of the University Observatory, Oxford, England, conveying a provisional statement in reference to measures and comparisons made of plates forwarded him by Professor Pickering. He writes in part: "The optical distortion on the plate is quite small, if existent—up to  $3^\circ$  from the center, and perhaps further. Whatever may be the ultimate definitive result as regards optical distortion, your plates will give (by the allowance for such distortion, which will be quite easy) as good places as we are getting on the plates for the Astrogaphic Catalogue. The images are perhaps a little larger and more diffused, but are quite easy to measure. This holds for certainly  $4^\circ \times 4^\circ$ , and probably further. If I am right in believing that fear of optical distortion was the motive for rejecting the photographic doublet the above conclusions show this fear to have been ground-

less, and the manifest advantages of getting a large field at once prove the doublet to be the right instrument, certainly for charting purposes. If you think this brief note will be of any interest at the Conference, please make use of it."

The subject of 'The November Meteors' was discussed, and Professor Pickering referred to the desirability of obtaining observations in various parts of the sky and in various longitudes, as indicated in a circular issued by the Harvard College Observatory. Professor Barnard recommended the short-focus lantern lens in the photography of the meteors. Professor Pickering referred to the fact that at present there seemed to be no available method of determining the direction of motion of the meteor from its trail on the plate. Professor W. H. Pickering suggested the desirability of pointing the camera in the neighborhood of the radiant. Third-magnitude meteors could thus be photographed. Professor Barnard indicated that meteors seemed to become visible some distance from the radiant. Professor Hale referred to Doctor Elkin's experience as indicating the photographic difficulties. Professor Searle stated that since small meteors appeared near the radiant, and large ones away from the radiant, it was probable that the body of the meteor concealed the light when near the radiant. Professor Eastman said the experience of most observers is that the largest meteors appear at some distance from the radiant. It seems quite likely that Professor Searle's hypothesis gives the true explanation. Professor Barnard thought that, since meteors must penetrate some distance before attaining high illumination, perspective would show them at some distance from the radiant. Professor Eastman suggested the photographing of persisting meteor trails. Professor Barnard had seen the smoke for ten minutes, and in one case thirty minutes, after the

flight of the meteor. The trails broke up into knots. Invariably the trails moved eastward among the stars. Mr. E. S. King referred to the accidental photograph of the spectrum of a meteor in the prismatic camera. Professor Hale regarded the photographic spectra of meteors as obtained at the Harvard College Observatory as of the highest value.

Professor Edward C. Pickering, as chairman of the committee appointed at the previous conference to secure the republication of the *Durchmusterung* charts, reported a list of some forty odd subscribers in America, and stated that the charts would shortly be published. Father Hagen stated that Doctor Küstner has written that numerous errors were being corrected, the largest list of these being furnished by Professor Pickering.

General plans for observing the total eclipse of the sun on May 28, 1900, were briefly discussed, and it was agreed by the Conference that unity in the methods of observation could be best attained by appointing a committee to consider the whole question and report on plans at the next conference. The Conference appointed as the committee, Pickering, Comstock and Barnard.

The matter of better organization of the United States Naval Observatory was brought before the Conference, and on motion a committee was appointed to solicit an expression of opinion on this subject from members of the Conference and other astronomers, the committee also to cooperate with similar committees from other scientific bodies in considering the general question of the reorganization of the scientific departments of the government. The Conference, by ballot, selected Professors Pickering, Hale and Comstock as the committee.

One of the most important questions brought before the Conference was the crea-

tion of a permanent astronomical and astrophysical society. It was formally resolved that it was desirable to form such a society, and a committee, consisting of Professors Hale, Comstock, Pickering, Newcomb and Morley, was appointed to report to the Conference on the subject. Subsequently the same committee reported a general plan, and was continued as a council further to consider the organization of the society and make arrangements for the time and place of the next meeting of the Conference.

A number of interesting instruments, apart from those developed and used in the complex work of the Harvard Observatory, were exhibited, and among them a zenith sector made by Rittenhouse, and a transit instrument and quadrant, all used by Andrew Ellicott in the last century. The exhibit of chronographs represented: The first Bond chronograph; the last chronograph made by the inventor, Richard F. Bond, and still capable of determining time to within a few thousandths of a second; a new form of electrically controlled chronograph of Professor A. G. Webster; and a Hough's Printing Chronograph, made by Edmund Kandler, of Chicago, for the Philadelphia Observatory. The latter instrument prints the minute, second and hundredth of the second. W. C. Bond & Sons, of Boston, also exhibited a break-circuit chromometer, and Professor Pickering an ingenious instrument for determining periods of periodic variations.

The following ninety-two persons were present at the Conference: C. G. Abbot, W. H. Attwill, S. I. Bailey, E. E. Barnard, N. E. Bennett, H. H. Brackett, Henry S. Carhart, F. L. Chase, H. Helm Clayton, W. H. Collins, H. R. Colson, G. C. Comstock, Charles R. Cross, A. E. Dolbear, Miss H. R. Donaghe, Charles L. Doolittle, H. W. Dubois, John A. Dunne, J. R. Eastman, Mrs. I. W. Eddy, W. S. Eichel-



berger, W. L. Elkin, S. P. Ferguson, R. A. Fessenden, Edward P. Fleming. Mrs. M. Fleming, Albert S. Flint, Edgar Frisby, R. H. Frost, Miss Caroline E. Furness, Miss E. F. Gill, H. M. Goodwin, Miss Ida Griffiths, J. G. Hagen, George E. Hale, J. F. Hayford, Miss Lillian Hodgdon, G. W. Hough, Harold Jacoby, E. S. King, Laurence La Forge, Miss E. F. Leland, F. H. Loud, C. Lundin, Alex. Macfarlane, Miss A. C. Maury, C. H. McLeod, D. C. Miller, Edward W. Morley, G. W. Myers, S. Newcomb, Henry M. Parkhurst, H. M. Paul, B. O. Peirce, Edward C. Pickering, Mrs. Edward C. Pickering, William H. Pickering, Charles Lane Poor, Miss Mary Proctor, Alden W. Quimby, F. G. Radelfinger, Wm. Maxwell Reed, Charles H. Rockwell, Jonathan T. Rorer, A. Lawrence Rotch, W. C. Sabine, F. E. Seagrave, Arthur Searle, Aaron N. Skinner, Frederick Slocum, M. B. Snyder, Charles E. St. John, John Stein, Miss M. C. Stevens, A. E. Sweetland, Winslow Upton, J. M. Van Vleck, Frank W. Very, Robert DeC. Ward, Charles F. Warner, W. R. Warner, A. G. Webster, Oliver C. Wendell, Miss Sarah F. Whiting, Frank P. Whitman, Miss Mary W. Whitney, Miss A. Winlock, Miss L. Winlock, Miss E. G. Wolfe, Miss I. E. Woods, R. S. Woodward, Paul S. Yendell.

At the close of the Conference Professor Comstock presented a motion recording the thanks of the Conference to Professor and Mrs. Pickering and the members of the Observatory staff for the generous hospitality of the Harvard College Observatory; to the President and Fellows of Harvard College for courtesies and hospitality extended; and to Professor Charles R. Cross for hospitality accorded by the Massachusetts Institute of Technology. With the unanimous adoption of this motion the Conference adjourned.

The undersigned begs to acknowledge his indebtedness to the members of the Con-

ference for generous aid given in the preparation of the foregoing report.

M. B. SNYDER.

GEOLOGY AND GEOGRAPHY AT THE AMERICAN ASSOCIATION MEETING.

I.

By the invitation of Section E (Geology and Geography) of the American Association, meetings of the Geological Society of America and of the National Geographic Society were held with this Section, the former in three sessions on Tuesday forenoon, afternoon and evening, August 23d, and the latter on Thursday afternoon, the 25th. These sessions, and those of Section E, were held in the lecture room of the Boston Society of Natural History, excepting the final session, on Friday forenoon, which was held in the geological lecture room of the Museum of Comparative Zoology, in Cambridge.

The address by the Vice-President of Section E, Professor Herman L. Fairchild, of Rochester, N. Y., on 'Glacial Geology in America,' was presented on Monday afternoon. It reviewed the history of the development of this branch of geology in the United States and Canada, concluding with the assertion that the origin of the North American drift through the action of a continental ice-sheet is now, after fifty years of exploration and discussion, as fully proved as any of the principles of geology. It is published in the September *American Geologist* and in the *Scientific American Supplement* for September 3d, 10th and 17th.

In the opening session of Section E, with the Geological Society, on Tuesday forenoon, short memorial addresses on the life and work of the late Professor James Hall were given by Professors Emerson, Fairchild and Niles, and by Dr. Horace C. Hovey, noting Hall's earnestness in boyhood and youth to acquire knowledge of geology and allied sciences, walking twenty

miles from his home in Hingham, Mass., to attend lectures by Benjamin Silliman before the Boston Society of Natural History, his distinguished services of more than sixty years on the Geological Survey of New York, and his recent illness and death, August 7th.

The papers presented before the Geological Society of America, with brief notes of their scope, mostly as stated in the Society's preliminary announcement, were as follows:

1. *Some Features of the Drift on Staten Island, N. Y.* By ARTHUR HOLLICK, Columbia University, New York City. The terminal moraine crosses Staten Island from Fort Wadsworth at the Narrows to Tottenville, opposite Perth Amboy, N. J. Its front rests partly on the serpentine ridge and partly on the plain region to the south. In the former locality it consists of true morainal material of the northern drift. In the latter it comprises a ridge or core of Cretaceous and Tertiary clays, sands and gravels, shoved forward and upward from their original position on the island, and on top of these disturbed beds are the morainal till and gravel. At two localities there are well defined indications of extra-morainic drift, south of the terminal moraine. The direction of glacial movement is indicated by the striæ on rock outcrops to be about S. 17° E.

The most abundantly represented boulders are those derived from the Triassic of New Jersey, although nearly all the outcrops between Staten Island and the Adirondacks have contributed. A list of about 120 Palæozoic fossils obtained from the transported boulders was appended to this paper, with another list of about 35 Cretaceous and Tertiary species, mostly fossil plants, derived from the disturbed Staten Island strata.

2. *Loess Deposits of Montana.* By PROFESSOR N. S. SHALER, Cambridge, Mass. (Read by title.)

3. *Glacial Waters in the Finger Lake Region*

*of New York.* By PROFESSOR H. L. FAIRCHILD, Rochester, N. Y. This paper noted the stages of glacial retreat and consequent changes of drainage, by which the glacial Lake Newberry, outflowing southward to the Susquehanna, was succeeded by Lake Warren, about 100 feet lower; and this, when the ice was further melted back, by Lake Iroquois. For the most definite stage between Lakes Warren and Iroquois, represented by a large beach at Geneva, N. Y., and by an old channel of eastward outflow south of Syracuse, the name Lake Dana is proposed.

4. *The Stratification of Glaciers.* By PROFESSOR HARRY F. REID, Baltimore, Md. Lantern views of the glaciers of Switzerland and Alaska were displayed, attention being directed to the author's observations of the persistency of the original stratification occasioned by the snowfall of successive years on the névé. This structure was distinguished from the transverse blue banding, analogous to cleavage, which is occasioned by pressure of the moving ice, being especially developed in constricted or very steep parts of the glaciers.

5. *Evidences of Epeirogenic Movements Causing and Terminating the Ice Age.* By WARREN UPHAM, St. Paul, Minn. The vertical amount of the preglacial elevation of North America, during late Tertiary and early Quaternary time, is shown to have ranged from 3,000 to 5,000 feet, according to the soundings of fjords and submerged valleys on our Atlantic, Pacific and Arctic coasts, the deepest of these valleys, exceeding 5,200 feet, near Monterey, California, having been described by Davidson a year ago. Similarly it is also known that a general uplift of western Europe and western Africa took place near the same time, of varying amount, from a minimum of probably about 1,500 feet in the British Isles to maxima of about 4,000 feet in Scandinavia, nearly 9,000 feet in the country adjoining the

southeast part of the Bay of Biscay, and more than 6,000 feet at the mouth of the Congo. These great uplifts are thought to have given the cold and snowy climate under which the ice-sheets were amassed. But the lands were afterwards depressed, in the closing, or Champlain, epoch of the Glacial period, to levels mostly somewhat below their present heights, whereby a temperate climate, with warm and even hot summers, was restored on the borders of the ice-sheets, melting them gradually from the periphery inward. Steep frontal gradients and vigorous glacial currents were thus produced, heaping much of the drift in prominent recessional moraines.

6. *Clayey Bands of the Glacial Delta of the Cuyahoga River at Cleveland, O., compared with those in the Implement-bearing Deposits of the Glacial Delta at Trenton, N. J.* By PROFESSOR G. FREDERICK WRIGHT, Oberlin, O. A year ago Professors Wright, Hollick, Mercer and Libbey made excavations at Trenton in the field where Mr. Ernest Volk has been working under the direction of Professor Putnam. As a result of their work, they found several implements from three to four feet below the surface, and beneath certain red clayey bands which they supposed to be a part of the original delta deposited at Trenton during the close of the Glacial period. In the meetings of the American and British Associations, however, at Detroit and Toronto last year, vigorous efforts were made by others to prove that these clayey bands do not belong to the original water deposition, but may have been wind-blown surfaces or lines of oxidation in the sand. During the past year Professor Wright has made numerous observations upon excavations in a similar delta of Glacial age at Cleveland, where he finds a succession of reddish clayey bands in the sand precisely similar to those at Trenton; and at Cleveland they merge into cross-bedded sand and gravel strata on the

same level, showing unequivocally that the whole is a water deposit, and that it has not been disturbed since the original deposition. This strongly confirms the inferences drawn a year ago concerning the age and undisturbed character of the deposits at Trenton from which Mr. Volk has derived so many implements for Professor Putnam, indicating that men were present, making, using and losing those implements at the time of departure of the ice-sheet.

7. *The Middle Coal Measures of the Western Interior Coal Field.* By H. FOSTER BAIN and A. T. LEONARD, Des Moines, Iowa. These coal measures are marked by non-persistence of strata. The upper measures are more regular. Between the two is a series partaking of the characteristics of each. This series includes the Raccoon River beds, the Appanoose formation and equivalents in Iowa, the Henrietta in Missouri, and the Oswego and Pawnee limestones of Kansas. No fitting general term for the whole has yet been proposed. The old term, middle coal measures, included the beds here referred to and the higher beds now quite generally known as the Pleasanton shales.

8. *The Principal Missourian Section.* By CHARLES R. KEYES, Des Moines, Iowa. The previous classifications of the Carboniferous formations of the region west of the Mississippi River were briefly outlined. The results of the recent work along the Missouri River were summarized and the inferences to be drawn were given. The Missourian series, as one of the four principal subdivisions of the Carboniferous of the continental interior, was described. Eleven well defined formations or stages are shown to have a wide distribution, the formations in five States being correlated.

9. *Tourmaline and Tourmaline Schists from Belcher Hill, Jefferson County, Colorado.* By HORACE B. PATTON, Golden, Colo. Black tourmaline, often in fine large crystals,



occurs very abundantly in pegmatite veins that cut the crystalline schists of the foothills of Jefferson county, west of Denver, Colorado. On the Belcher Hill road, near Golden, the tourmaline occurs: (a) in separate crystals; (b) in black masses (schorl) in quartz veins; (c) the same in pegmatite veins; and (d) in finely disseminated needles replacing biotite and even feldspar and quartz in biotite schists and gneisses at contact with veins of pegmatite and quartz. The beautiful banding and cross-banding produced by this replacement is unusual. The paper was illustrated by specimens and photographs.

10. *Magmatic Differentiation in the Rocks of the Copper-bearing Series.* By ALFRED C. LANE, Houghton, Mich. In many of the effusive sheets a difference may be noted between the top and the bottom. At the top the feldspar is oligoclase, at the bottom labradorite. At the top olivine is more conspicuous, at the bottom augite. The oligoclase and olivine were evidently formed before the lava from which the sheet was formed came to rest, at least in part. The augite and labradorite were probably formed later. It is possible that the early formed oligoclase rose to the top, and that the sodiferous magma there formed had not such corrosive action on the olivine as the calcareous magma left below, the latter causing the olivine to be changed to augite. Comparing different flows, we find the same kind of relations that exist between the top and bottom of the same flow. This suggests that similar differentiation went on before eruption.

11. *The Volume Relations of Original and Secondary Minerals in Rocks.* By PROFESSOR CHARLES R. VAN HISE, Madison, Wis. This paper discusses the volume relations of secondary minerals as compared with original minerals, and considers this volume change in reference to the depth at which the alteration occurs.

12. *Note on a Method of Stream Capture* By ALFRED C. LANE, Houghton, Mich. When the divide between two streams is porous, and the valley of one much deeper than that of the other, springs may arise on the side of this deeper valley, which drain the water from the higher valley and thus diminish the erosive capacity of the stream therein, until the higher valley has a stream only in times of rain and is soon eaten into by lateral tributaries of the deeper stream. Various illustrations of this action were given, and it was noted that the streams draining the ice-front during the Glacial period were especially liable to capture because they occupied channels heavily filled with porous gravel and sand.

13. *The Development of the Ohio River.* By PROFESSOR WILLIAM G. TIGHT, Granville, Ohio. A brief review of the literature shows that it has been generally accepted that the Ohio River is a very ancient stream, but recently the work of several geologists in New York and Pennsylvania indicate the Pleistocene origin of the Ohio above New Martinsville. In papers already published by the author the existence of a very ancient erosion basin extending in general from east to west through the central part of Ohio and Indiana is established by the restoration of many tributary drainage lines and by deep wells. Further evidence is presented in this paper to show that the Ohio in its present location has been established through the appropriation of sections of numerous northwardly and northwestwardly flowing streams by the cutting of the ancient cols and the broadening and deepening of the valleys. The explanation for these changes is found in the position and action of the ice-sheet in the various sections, thus determining the age of this part of the Ohio valley to be Glacial or Postglacial.

The theory is proposed that the development of the Ohio River almost entirely be-

yond the greatest extent of the ice-sheet, and of the Missouri River almost entirely within the limits of the ice, was due to the different angles which these streams made with the ice-front, and to their different gradients. In the Ohio basin the water was forced over distant cols; but in the Missouri basin it was drained southeastward along the ice-front, thus wearing back the ice at the time of final recession before the establishment of the channel by erosion.

14. *Classification of Coastal Forms.* By F. P. GULLIVER, Southboro, Mass. A scheme is proposed in this paper for the classification of the various forms of the coast according to their stage of development. Two markedly different classes of initial forms are recognized, those following elevation of the land and those following depression. Each class is seen to have characteristic forms at various stages of its development, and the writer urges others to think of all the forms on the coast or along the shore as in a certain stage of their life-history. This will further suggest the form from which any given example has come and toward which it tends to develop.

15. *Dissection of the Ural Mountains.* By F. P. GULLIVER. The Urals are seen to be pretty thoroughly planed, so that the summits of the many ridges rise to nearly the same elevation, except a few commanding peaks which are found to consist of quartzite or other rock more resistant than the surrounding beds. The summit-level plane descends gradually to the west until it merges into the upland levels of the great plain of Russia, while on the east in several places there is a rather steep fall-off to the Siberian plain, though in other places the plane of the summits merges into that of the great Tertiary deposits of northwestern Asia. The stages of dissection in various parts of the Ural Mountains, and the grade-planes of different streams, are compared, the result of such comparison being that

there seem to be three epicycles or divisions of the present cycle of erosion.

16. *Note on Monadnock.* By F. P. GULLIVER. The relation of Monadnock to the New England upland was considered, and the valleys in the vicinity of this mountain were described. The elevations of two former stream grades have recently been determined in this region.

17. *Spacing of Rivers with Reference to the Hypothesis of Baseleveling.* By PROFESSOR N. S. SHALER, Cambridge, Mass. (Read by title.)

18. *The Continental Divide in Nicaragua.* By C. WILLARD HAYES, Washington, D. C. The comparatively short streams, with steep gradients, descending to the Pacific, have in numerous instances increased their drainage basins by capture of the headwaters of streams flowing eastward to Lake Nicaragua and the Caribbean Sea. In this way the water divide on the surveyed line for the Nicaragua Canal has been removed a considerable distance eastward, being now at a much lower altitude than the original mountainous watershed.

The following papers were presented in the session of the National Geographic Society :\*

1. *The Venezuela-British-Guiana Boundary Dispute.* By DR. MARCUS BAKER, Washington, D. C.

2. *Considerations Governing Recent Movements of Population.* By JOHN HYDE, Washington, D. C.

3. *Some new Lines of Work in Government Forestry.* By GIFFORD PINCHOT, Washington, D. C.

4. *The Development of the United States.* By W J MCGEE, Washington, D. C.

5. *Atlantic Estuarine Tides.* By M. S. W. JEFFERSON.

6. *The Forestry Conditions of Washington State.* By HENRY GANNETT, Washington, D. C.

\* See the account by W J M in the issue of SCIENCE for September 16th.

7. *The Five Civilized Tribes and the Topographic Survey of Indian Territory.* By CHARLES H. FITCH, Washington, D. C.

8. *Bitter Root Forest Reserve.* By RICHARD U. GOODE, Washington, D. C.

The papers of Section E of the Association were as follows :

1. *Outline Map of the Geology of Southern New England.* By PROFESSOR B. K. EMERSON, Amherst, Mass. This paper, with maps, gave a summary of the areal geology of Massachusetts, Rhode Island, Connecticut, and parts of New Hampshire, Vermont and New York.

2. *Basin in Glacial Lake Deltas.* By PROFESSOR H. L. FAIRCHILD, Rochester, N. Y. During the glacial recession the impounded high waters of the Canandaigua valley, in central New York, at one time escaped across the eastern border of the basin into the Flint creek valley, which was also occupied by a glacial lake at a lower level. The river thus formed cut a channel in drift and rock, and deposited the débris, as a delta, at its mouth in the lower lake. The delta now forms a conspicuous plateau of gravel 125 feet above the adjacent village of Potter. In this plateau is an irregular depression which reaches to the very base of the delta deposit, and occupies, perhaps, a fourth of the area of the plateau. The only satisfactory explanation of its origin is that an isolated block of ice was left there by the receding ice-front, and that the delta material was piled around it, the subsequent melting of the iceblock producing the cavity. Elsewhere shallow basins occurring in deltas are in many cases attributable to deficient filling by capricious currents and wave action; but such bowls cannot be confounded with the Potter kettle-hole, which was illustrated by a map and photographs.

3. *An Exhibition of the Rare Gems and Minerals of Mt. Mica.* By DR. A. C. HAMLIN, of Bangor, Maine. (Read by title.)

4. *The Hudson River Lobe of the Laurentide Ice-sheet.* By PROFESSOR C. H. HITCHCOCK, Hanover, N. H. The glacial drift and striæ of Quebec, New England and New York prove the existence of a glacial lobe following the Champlain-Hudson valley. The movement was to the southeast over the summits of the White and Green Mountains and to the southwest over the Adirondacks, but due south along the medial valley. Last October the author climbed Orford Mountain, which rises northwest of Lake Memphremagog to an altitude of about 5,000 feet above the sea, and found it glaciated from bottom to top, wholly in a southeasterly course. All over the mountain were found boulders of Laurentian gneiss, which (according to their determination by Professor Frank D. Adams, of Montreal) must have come from the north side of the St. Lawrence River. It had before been shown that the highest mountains of New Hampshire and Vermont were glaciated from the northwest, but doubt had been lately expressed about Orford Mountain. These observations prove that the Laurentide ice-sheet overrode all these mountains, flowing from the region north of Montreal and Quebec southward and southeastward to the sea border.

5. *The Age of the Amboy Clay Series as indicated by its Flora.* By ARTHUR HOLLICK, Columbia University, New York City. Investigations in the paleobotany of the Amboy Clay series and the equivalents on Staten Island, Long Island, Block Island and Martha's Vineyard, conducted during the past twenty years by the late Dr. J. S. Newberry, Dr. Lester F. Ward, Mr. David White, the writer and others, have shown that the formation which includes them is very closely related to the Atane and Patoot beds of Greenland, the Dakota group of the West, the Alburpean series of the South and the Cenomanian of Europe, so that there was no hesitation in declaring them



all to be Middle Cretaceous in age. This conclusion seemed to be quite generally accepted and was apparently not questioned until about two years ago, when an announcement was made, with some show of authority, that the series is probably Jurassic in age. In regard to the correlation of the several formations mentioned there can be no question. The large amount of paleobotanical material available for comparison has given opportunity for the identification of so many species common to them all that this conclusion is not only justifiable, but inevitable, and the only question is whether the correlation also demonstrates that the several formations are Middle Cretaceous in age. If any one of them is, then they all are; if any one is not, then the others are not.

In paleobotany, as in paleozoology, the broad general facts are recognized that the biological sequence is coincident with the geologic sequence, and that the farther back in geologic time the simpler and lower in the scale of life were the organisms. Hence, if we divide our fossil flora into the three great classes of cryptophytes, gymnosperms and angiosperms, the sequence of their appearance and periods of maximum development would be in the same order. The percentages of these classes in any floras should, therefore, be a fair indication of the relative ages of the floras. A typical Jurassic flora, such as that of Siberia, contains, roughly, the following percentages: cryptophytes, 22; gymnosperms, 74; and angiosperms, 4. The Older Potomac flora, which is regarded as Lower Cretaceous, contains the same classes in the percentages of 39, 39 and 22; the Newer Potomac, regarded as Middle Cretaceous, 8, 13 and 79; the Amboy clays, 6, 13 and 81; the Dakota group, 1, 5 and 94. Similar examples of floras are also calculated for other floras regarded as Cretaceous in age. The main fact, which is at once seen,

is the manner in which the percentages of the gymnosperms and angiosperms are reversed. Few angiosperms, and only those of doubtful character, have been found in any formation recognized as Jurassic, so that when it was ascertained that in the Amboy Clay flora and its equivalents the angiosperms represent from 70 to 90 per cent. of the entire flora there was little hesitation in considering it as well advanced in the Cretaceous period. There would be nothing inconsistent in regarding the lowest of the Older Potomac strata as Jurassic, but even there it would require definite paleontologic evidence, while in regard to the Amboy Clay series it is safe to say that a Jurassic fauna will never be found in connection with its flora.

In face of the direct evidence of the fossil flora, therefore, it would seem a very hazardous undertaking, without ample evidence in rebuttal, to draw the line of separation between the Jurassic and Cretaceous so that in the West the base of the Cretaceous would be represented by the Dakota group and in the East by the clay marls of the Matawan formation. (The paper was illustrated by tables of percentages and charts.)

6. *Some Feldspars in Serpentine, in Southeastern Pennsylvania.* By PROFESSOR T. C. HOPKINS, State College, Pa. Feldspar occurs in this district as dikes or veinlike masses in serpentine, sometimes attaining a thickness of 20 to 25 feet. The most extensive area is in Chester county, extending also into Lancaster county; but there is another area in central Chester county, near the corundum mines. The feldspar is snow-white to pink in color, and seems to be wholly orthoclase. Some of the dikes have been exploited to a depth of 60 feet.

7. *The Region of the Causses, in Southern France.* By REV. HORACE C. HOVEY, Newburyport, Mass. Lofty tablelands in the Departments of Lot and Lozère, along the

western declivity of the Cevennes Mountains, are known as the Region of the Causses. The term 'causse' is derived from the Latin word *calx*, meaning limestone. Some of the finest roads in Europe run along the plateaus, and occasionally descend into the valleys. But the author's exploration, here noted, led by E. A. Martel, of Paris, left all beaten paths at the village of St. Enimie, launched in canoes, and followed the winding gorges of the Tarn for 46 miles, and then, by mules or in carriages, explored the gorges of the Jonté and Durbais. The Causses vary in height from 1,000 to 5,000 feet above the sea, and these gorges are cut through them somewhat as the Grand Canyon of the Colorado cuts through the plateaus of Arizona. The cliffs of the river Tarn are often from 1,000 to 2,000 feet high, and occasionally still higher, and are brilliantly colored.

The caverns of the region are as remarkable as any in Europe. There are hundreds of them, and of all sizes. Among the large caverns explored by this party may be mentioned those of the Banmes Chaudes, three in number. From one of them the late Dr. Prunières exhumed 300 prehistoric skeletons, and in another are nine vertical pits from 40 to 127 feet deep. Another cave destined to become famous is that of Darjelan, with twenty halls from 65 to 600 feet long, the lowest of them being 420 feet deep. The author's party discovered and explored the Aven Armand, down whose chasm Louis Armand was the first to go. This vertical pit is 240 feet deep, beyond which is another 300 feet deep, the total vertical depth being 600 feet by actual measurement. The descent was made by a series of rope ladders, and was not without its dangers. The stalactitic decoration of these caves is remarkably fine.

The term 'aven' is applied to what we call a 'sinkhole,' except that the avens seem to pass more abruptly into pits or

chasms. They pierce the Causses from the drainage level, and are death-traps for animals whose remains were found below in various stages of decomposition and whose bones lie imbedded in the dripstone. The theory is that every aven has a passage-way to the rivers of the region. That this is often so is proved by the great springs at the base of the cliffs of the Tarn; but in some cases the subterranean passages trend away from the streams instead of toward them, and often they are dry, showing that the drainage must have been at some remotely ancient period.

Should it be asked why the wonderful Region of the Causses has so long escaped exploration amid a country of high antiquity, the answer is that these lofty plateaus are barren solitudes, except for the chalets of wandering shepherds. The gorges and avens have been objects of dread instead of places attracting visitors. The superstitions of the peasants have also operated to make them shun what a few tourists now delight to explore. Under the stimulus of the Société de Spéléologie, the region is being opened to the public, and it is destined to be resorted to by thousands of tourists when its interesting features become more widely known.

8. *The Washington Limestone in Vermont.* By C. H. RICHARDSON, Hanover, N. H. This name is proposed by the author for the more calcareous member of the Calcareous mica schist of Professor C. H. Hitchcock. It is for the most part a very dark silicious rock, the color of which is due to finely disseminated carbon. This formation, varying from 2,000 to 5,800 feet in thickness, extends from south to north through Vermont; but its most important development, economically, is in the townships of Washington and Topsham, Orange county, where, within the past five years, numerous valuable marble quarries have been opened in it. The chemical compo-

sition of specimens of this marble from a deep test pit at one of the quarries is very remarkable, no less than eighteen elements having been detected in its analysis.

9. *Fluctuations of North American Glaciation shown by Interglacial Soils and Fossiliferous Deposits.* By WARREN UPHAM, St. Paul, Minn. From a comparison of our continental drift deposits with the present retreatal conditions of the piedmont Malaspina glacier in Alaska, it is concluded that the fauna and flora adjacent to the retiring ice-sheet were nearly like those of the same latitudes to-day, and that fluctuations of the ice border to the extent of a few miles, a few score, or a few hundred miles, more acceptably account for our interglacial beds, former surface soils and leached subsoils, than a general departure and renewal of the ice-sheet.

10. *Time of Erosion of the Upper Mississippi, Minnesota and St. Croix Valleys.* By WARREN UPHAM. Until the Ozarkian epoch of great elevation of the northern part of this continent, inaugurating the Quaternary era, the upper part of the present Mississippi basin, above the vicinity of Dubuque, appears to have been drained northerly, according to recent studies by Hershey (*American Geologist*, Vol. XX., pp. 246-268, October, 1897). After the Cretaceous marine submergence of the State of Minnesota, its chief river system probably flowed through the Red River Valley to Hudson Bay during the Tertiary era, being reversed to take nearly the course of the Minnesota and Mississippi Rivers at the end of that era. The St. Croix River is thought by the author to have obtained its passage through the rock gorge of the Dalles at Taylor's Falls, Minn., so late as the Buchanan Interglacial epoch, preceding the Illinoian and Iowan glacial readvance; and the channel of the Mississippi from Minneapolis to Fort Snelling, eroded during the Postglacial period, has afforded to Professor N. H. Winchell his

well-known estimate of that period as between 7,000 and 10,000 years.

11. *Supposed 'Corduroy Road' of Late Glacial Age, at Amboy, Ohio.* By PROFESSOR G. FREDERICK WRIGHT, Oberlin, Ohio. This paper detailed the discovery of a series of logs lying side by side as in a corduroy road, and extending for a distance of 200 feet or more, which were covered by 30 feet of gravel, in which were found the tooth and tusk of a mammoth, the tusk being 10 feet long, 22 inches in circumference at the base, and weighing 155 pounds. The resemblance to a corduroy road was, indeed, very striking, but the appearance of the logs showed that they were driftwood, and had been buried by the accumulation of the gravel that took place along the old shore of Lake Erie, when, during the closing centuries of the Glacial period, the water was held up to a level 150 feet higher than now. The logs and base of the deposit are 140 feet above the lake and about 4 miles back from it, on the banks of Conneaut Creek, in the extreme northeastern corner of Ohio. The gravel was evidently brought down from the higher lands of the south, near the sources of the creek, and was deposited with the mammoth remains in a delta at the edge of this old glacial lake. In connection with this investigation it was ascertained that similar deltas of gravel characterize the margin of the old lake where other streams from the south met it at various places between this point and Cleveland. Altogether, these observations give a very vivid picture of the rapidity with which coniferous forests proceeded to cover northern Ohio as the ice melted back, and of the promptness with which the immense animals of the time reoccupied the territory. Important inferences are also derived, showing that the period of time during which the water remained at the high levels of the old ice-dammed lakes was short.



12. *Changes in the Drainage System in the Vicinity of Lake Ontario during the Glacial Period.* By DR. M. A. VEEDER, Lyons, N. Y. The paper noted sections of wells in buried river channels south of Lake Ontario, from the Niagara River eastward to the Mohawk Valley.

13. *Recent Severe Seismic Movements in Nicaragua.* By JOHN CRAWFORD, Managua, Nicaragua. Description of a series of earthquakes experienced in western Nicaragua from April 29th to May 12th of this year, as reported by the author in the *American Geologist* for July (Vol. XXII., pp. 56-58).

WARREN UPHAM,

*Secretary of Section E, 1898.*  
(To be Concluded.)

#### THE BOTANICAL SOCIETY OF AMERICA.

THE fourth annual meeting was held at Boston, August 19 and 20, 1898, under the presidency of Dr. N. L. Britton.

In the absence of Professor C. R. Barnes, Secretary, Dr. B. L. Robinson was elected Secretary *pro tem*.

The following new members were elected: Robert A. Harper, University of Wisconsin, Madison; Edward A. Burt, Middlebury College, Middlebury, Vt.; Herbert J. Weber, Department of Agriculture, Washington, D. C.; L. H. Pammel, Iowa Agricultural College, Ames; Albert S. Hitchcock, Kansas Agricultural College, Manhattan; Herbert Maule Richards, Harvard University, Cambridge, Mass.; David G. Fairchild, Department of Agriculture, Washington, D. C.; David M. Mottier, University of Indiana, Bloomington.

In the absence of the retiring President, Professor John M. Coulter, his address, entitled 'The Origin of Gymnosperms and the Seed Habit,' was read by Dr. B. M. Davis. It has been published in this JOURNAL.

The following papers were presented:

1. On Sporogenesis in *Arisevna*. By Professor George F. Atkinson.

2. Symbiotic Saprophytism. By Professor D. T. MacDougal.

3. Sporogenesis in *Trillium*. By Professor George F. Atkinson.

4. The Structure and Development of the Centrosphere in *Corallina*. By Dr. E. M. Davis.

5. Relations Between the Forest Flora and Geological Formations in New Jersey. By Dr. Arthur Hollick.

6. Preliminary Notes on the Fertilization of the White Pine. By Miss M. C. Ferguson (by invitation of the Council).

7. Notes on a *Helianthus* from Long Island. By Dr. N. L. Britton.

8. Tetrad-formation in *Tsuga*. By W. A. Murrill. (Presented by Professor Atkinson.)

9. A Fossil Moss from the State of Washington. By Mrs. E. G. Britton and Dr. Arthur Hollick.

The following officers were elected for the ensuing year: President, Professor L. M. Underwood; Vice-President, Dr. B. L. Robinson; Treasurer, Dr. Arthur Hollick; Secretary, Professor Geo. F. Atkinson; Councillors, Professor C. E. Bessey and Dr. W. P. Wilson.

#### MEETING OF THE AMERICAN FORESTRY ASSOCIATION AT BOSTON.

THE meeting of the American Forestry Association, held in connection with the American Association for the Advancement of Science, was chiefly interesting for the reports of progress of the forestry movement. The sessions were held at Horticultural Hall, on Tuesday, August 23d, to Thursday, August 25th. The social features and excursions of interest, lavishly provided by a local committee and the Massachusetts State Forestry Association, formed a prominent part of the meeting. The opening session was mainly occupied by reports from delegates of various States as to the condition of the forestry movement. Forest Commissioner Rothrock, of Pennsylvania, reported progress in the establishment of State Forest Reserves. Mr. Austin Cary, of Maine, referred to his employment by a paper-pulp manufacturing company to direct the logging of their large forest

property according to forestry principles. Forest Commissioner Fox, of New York, reported on the acquisition of Adirondack lands by the State to the extent of one and a-half million dollars. On Tuesday afternoon the Association, in a body, drove through the Middlesex Fells, and the discussions in the evening, after a dinner at the hotel situated in the forest park, turned naturally on the application of silviculture to such parks. It appeared that the Metropolitan Park Commission had not yet formulated plans as to the management of the woodlands. Dr. Schenck, of Baltimore, and Mr. Olmstead, of the well-known firm of landscape architects, advocated sound measures for the replacing of the worthless coppice growth, which is bound to deteriorate, by a healthy seedling growth.

An important feature of the meeting was the discussion of the aims and objects of the newly established State College of Forestry at Cornell, by its Director, Dr. B. E. Fernow. This address will be printed in full in SCIENCE. In the discussion Professor Lazenby referred to a movement in similar direction which was shaping itself in Ohio. Among the usual resolutions which it is the custom to pass at these meetings the most important was one calling upon the federal government to place its forest reserves under technical non-political management.

The Association adjourned to hold another summer meeting at Omaha, in connection with the Trans-Mississippi and International Exposition.

---

#### NOTES ON PHYSICS.

##### GAY LUSSAC'S LAW AND ATMOSPHERIC NITROGEN.

A VERY curious deviation of atmospheric air from the Laws of Gay Lussac and Boyle has been studied by H. Teudt (*Zeit. für Phys. Chem.*, XXVI., p. 113). When first

heated, the expansion above 350° is excessive. The deviation from Gay Lussac's Law being 2 per cent. at 400° and 3 per cent. at 450°. This anomalous expansion is exhibited by atmospheric nitrogen alone, but not by oxygen, carbon dioxide, chemically prepared nitrogen, by air which has been previously heated, nor by air collected after a rain. Teudt suggests, in explanation, the existence of an allotropic form of nitrogen and points out that the close relationship between nitrogen and phosphorus supports this view; the allotropic form of nitrogen being changed to the ordinary form at high temperatures. Holborn and Wien, in connection with their work on the air thermometer, have pointed out that air at the first heating does not conform to Gay Lussac's Law.

#### LIQUID AMMONIA.

E. C. FRANKLIN (Paper read before Section C at Boston) has made an elaborate study of liquid ammonia, which has been known for some time to approach water in its properties as a solvent. He finds its heat of vaporization to be about 330, while the calculated value is 358 by Trouton's formula, 321 by the formula of Wood, and 330 by the formula of Peabody. He finds the constant of molecular elevation of the boiling point of liquid ammonia to be 3.4, which is lower than for any other known substance. He has measured the electrical conductivity of various substances dissolved in liquid ammonia, and he finds the conductivity to increase with temperature, reach a maximum and then decrease, becoming zero at the critical temperature of liquid ammonia.

H. M. Goodwin (Paper read before Section B at Boston) has determined the dielectric constant of liquid ammonia and finds it larger, indeed, than the dielectric constants of alcohol, ether and the like, but not so nearly equal to that of water as was

expected from its electrolytic dissociating power.

#### MEASUREMENT OF THE INTENSITY OF SOUND.

INSTRUMENTS for the measurement of sound intensities were described before Section B at Boston by Professor A. G. Webster and by Dr. J. O. Reed. In Professor Webster's instrument the amplitude of vibration of a thin glass diaphragm is measured by the interferometer, the fringes being photographed on a moving plate. In Dr. Reed's instrument the amplitude of vibration of a diaphragm is observed by means of a micrometer microscope focussed upon the tip of a stylus attached to the diaphragm.

Professor Webster outlined a method for calculating the absolute intensity of the sound (amplitude of the periodic force acting upon the diaphragm) from the observed amplitude of vibration. In this outline Professor Webster made use of the equation of motion of a system with one degree of freedom, namely,

$$\frac{d^2x}{dt^2} + \beta \frac{dx}{dt} + ax = Ae^{pt}.$$

Now, this equation is, in fact, applicable to any system vibrating in a given simple mode (*i. e.*, when the period of each particle of the system is the same and its amplitude a one valued function of its position) but it is impossible to determine the coefficient  $a$  by static measurements of any kind. The effect of the air which vibrates with the diaphragm can, however, be taken into account so that the coefficient  $a$  may be approximately determined, by using as a resonator a long air column. However, the results of some determinations by Professor Webster agree quite well with sound intensities as measured by Rayleigh.

W. S. F.

#### NOTES ON INORGANIC CHEMISTRY.

THE first number of the *Chemical News* in September is known as the 'Students' Number,' and is devoted to a description of the chemical departments of the British universities and colleges. It is noticeable at once that the facilities for chemical study in Great Britain are very far behind those of Germany, and I think we may fairly say below those of America. Probably a dozen or even more institutions could be found in this country where greater advantages are offered than anywhere in England. Three colleges only have more than one professor in the chemical department, viz.: Victoria University, Yorkshire College, Leeds, with a professor in the dyeing department, and a professor in the leather industries department, in addition to the professor of chemistry; Owens College, Victoria University, Manchester, with a professor of chemistry and a professor of organic chemistry; Glasgow and West of Scotland Technical College, with a professor of chemistry and a professor of technical chemistry. The Royal College of Science and Royal School of Mines has, in addition to a professor of chemistry, an assistant professor, and King's College has a professor of metallurgy. In the number of teaching force also the British colleges would seem to be deficient. The average number of instructors, including all assistants and demonstrators, in the twenty-nine colleges mentioned is less than four, and this average is strongly brought up by Owens College and Yorkshire College, each of which has a corps of ten instructors, and the University College, Liverpool, with seven. The two former would appear to be the only colleges of Great Britain with adequately equipped chemical departments; Oxford and Cambridge hardly seem to be in the race.

THE same number of the *Chemical News* contains, as its single item of current news,



the statement that the War Office authorities have decided to do away with part of the scientific training at the Royal Military College at Woolwich, by closing the chemical laboratory—a curious step backwards for modern times.

IN investigating pitchblende to find why the activity of the Becquerel rays is not proportionate to the amount of uranium present, a rule holding in general for compounds of uranium, M. P. Curie and Mme. S. Curie have isolated a new substance which appears to be a new metal. It is, according to the *Comptes Rendus*, thrown down with the bismuth sulfid and partly separated by heating in vacuum to 700° C., the sublimate obtained having 400 times the activity of uranium. The spectrum, however, emits no characteristic lines. The name of *polonium* is suggested for the new substance, from the country where the pitchblende was found. J. L. H.

#### ZOOLOGICAL NOTES.

IN a recently issued excerpt from the Bulletin of the U. S. Fish Commission, Dr. Hugh M. Smith treats of the Florida Commercial Sponges, briefly describing the species taken and discussing the causes of their decrease and the possible remedies for it. The causes of decrease are the usual ones, the taking of small sponges and excessive fishing; the proposed remedies are the enforcement of the laws against taking small sponges and the prohibition of sponging on certain grounds for definite periods. From the very rapid rate of growth assigned to the most valuable species, the sheepswool sponge; it is evident that the restocking of the depleted sponge beds would be a very simple matter if the above remedial measures could be enforced. Dr. Smith tells us that experiments seem to show that the sheepswool may, under favorable conditions, attain a weight of one tenth of a pound in six months and reach

a commercial size in a year. He considers that sponge culture promises well for Florida waters, where, for some reason, growth is more rapid than in the Mediterranean. On the other hand, the introduction of Mediterranean sponges is regarded as problematical, and it is a question if the introduced sponges would retain their superiority under the changed environment. The paper is illustrated by numerous half-tone plates of commercial sponges.

F. A. L.

#### CURRENT NOTES ON ANTHROPOLOGY.

##### THE ZOQUE LANGUAGE.

AN important contribution to American linguistics is the 22d volume of the 'Bibliothèque Linguistique Américaine' (Paris, Maisonneuve), which has just appeared. It is entitled 'Langue Zoque et Langue Mixe,' and is edited by M. Raoul de la Grasserie (1898, pp. 384). Most of it is occupied with the Zoque, of which a grammatical outline is given and a vocabulary of nearly 7,000 words from the MS. of Father Luis Gonzales (1672). This is further compared with the modern Zoque as spoken at present in Chiapas.

The Mixe is represented by the Grammar of Father Quintana (1730), a short vocabulary and some texts.

The work closes with a comparison of the Zoque and Mixe, showing them rather closely related members of the same stock, though with notable differences in words and in morphology, especially that the Mixe prefixes the pronoun in the conjugation, while the Zoque suffixes it.

M. de la Grasserie has edited these materials with great care, and the volume is a valuable addition to linguistic literature.

##### THE ANTHROPOLOGY OF BRUNSWICK.

ON the occasion of the meeting this year of the German Anthropological Society at Brunswick, a little volume has been issued

on the anthropology of that duchy ('Beiträge zur Anthropologie Braunschweigs,' pp. 163, 1898, Braunschweig, Vieweg). It contains nine essays by local writers, beginning with the remains of palæolithic man in the 'diluvial' strata by Dr. W. Blasius. The relics seem to be adequate to proving his presence at that time. The jade axes found in the region are described by Professor Kloos; the bronzes by Instructor Voges; the medieval vessels by Dr. Hänselmann; ancient skulls by Dr. Berkhan; local peasant costumes by Dr. Richard Andree; wood carving by Mr. Vassel; megalithic monuments by Inspector Grabowsky; and some curious folk-lore by Pastor Schattenberg. The illustrations are abundant and good.

This is an excellent idea, and ought to be followed in other localities on such occasions.

#### THE QUERANDIES.

AN extended monograph on Argentine ethnography has recently appeared from the pen of Felix F. Outes ('Los Querandies,' Buenos Aires, 1897, pp. 202; illustrated). It is a study of the culture and affiliations of the tribe which, at the discovery, occupied the site and vicinity of the modern city of Buenos Aires. They were known to early writers as the Querandis, a Guarani term of no ethnic significance. Some authorities have claimed them as of the Guarani stock, others as of Pampean (Aucanian) origin. Mr. Outes, following Lafone Quevedo, holds them to have been of Guaycuru affinity. Only a few proper names remain, and their relics, which he studies at length, are not decisive. The evidence, however, leans in his favor. The same can not be said when he includes their neighbors to the north, the Charuas, in this family also. There is negative evidence which would place those either as a separate stock or among the Brazilian families.

D. G. BRINTON.

UNIVERSITY OF PENNSYLVANIA.

#### SCIENTIFIC NOTES AND NEWS.

At the recent meeting of the British Association Professor W. Ramsay and Dr. Morris Travers announced the discovery of a new elementary constituent of air, which they named xenon, the stranger. It has been separated from both air and argon by the process of liquefaction and subsequent distillation. It has a well-marked spectrum, similar in general character to that of argon, and, like it, greatly altered in appearance by the interposition of a jar and spark-gap; but the positions of the lines of the spectrum differ totally from those of argon lines.

THROUGH the generosity of Mr. Cornelius Vanderbilt, the New York Botanical Garden is about to undertake a botanical exploration of the island of Porto Rico. The expedition, which is now being organized, will leave for the new colony within a few weeks, and will carry on collecting of museum and herbarium specimens and living plants for at least six months. Inasmuch as very little is yet known concerning the natural flora of the island, it is confidently expected that much of value and interest will be secured, and the collections will furnish the basis of a report on the botany and vegetable productions of our newly-acquired territory.

DURING the past summer much progress has been made in the New York Botanical Garden, in Bronx Park. The construction of the Museum building has proceeded rapidly, three-fourths of its steel frame being in place, the walls being completed as far as the second story. The warm and wet summer has been favorable to the plants. Much progress has been made in planting the border, which will be completed during the autumn. It will be about two miles in length and will contain some three hundred and fifty varieties of trees and shrubs.

A STATUE of Van Beneden, the eminent zoologist, has recently been unveiled at Malines.

DR. ARTHUR BORNTRÄGER has been appointed Director of the Agricultural Station at Palermo.

MR. W. H. HOLMES, of the United States National Museum, has gone to California to visit the Caliveras region.

DR. EUGENIO BETTONI, Director of the Fisheries Station at Brescia, died on August 5th at the age of fifty-three years.

THE sessions of the New York Academy of Sciences will this year be held in the rooms of the American Society of Mechanical Engineers, 12 West Thirty-first Street. It should be remembered by those interested that the Academy meets on Monday evenings at eight o'clock, the first Monday in the month being given to the Section of Astronomy and Physics, the second Monday to the Section of Biology, the third Monday to the Section of Geology and Mineralogy, and the fourth Monday to the Section of Anthropology, Psychology and Philology. The annual meeting and presidential address will be on February 27th.

THE other societies forming the Scientific Alliance of New York, which is so greatly in need of a building of its own, will hold their meetings at the following places: The Torrey Botanical Club, at the College of Pharmacy, 115 West 68th Street; The New York Microscopical Society, at the Motte Memorial Library, 64 Madison Avenue; The New York Section of the American Chemical Society, at the College of the City of New York; The New York Mineralogical Club, at the rooms of the American Society of Mechanical Engineers; The American Mathematical Society, at Columbia University; The Linnæan Society of New York and the New York Entomological Society, at the American Museum of Natural History.

A NEW building has been erected for the Maryland Geological Survey in the rear of the one occupied at present by the Survey and the Weather Bureau, on Howard Street, Baltimore. It is of brick, two stories high, 20 feet wide by 50 feet long. It will be used for experiments and for depositing large pieces of machinery.

THE government of New Zealand offers a prize of \$10,000 for improvements in the process of treating the native fibre (*Phormium tenax*), known as New Zealand flax. The successful competitor will not be required to surrender title to his invention, or to permit a free use of it in the country which offers the reward.

CONSUL-GENERAL LINCOLN, writing from Antwerp, notes that 78,220 pounds of African ivory

and 55 pounds of hippopotamus tusks were offered at the quarterly sale of August 2d, the stock on hand being about 174,628 pounds. One can but wonder how long the elephant will continue to exist.

THE American Public Health Association held its Twenty-sixth annual meeting at the Parliament Building, Ottawa, Canada, on September 28th, 29th and 30th, under the presidency of Dr. C. A. Lindsay, of New Haven, Conn. The Executive Committee selected the following subjects for consideration: Pollution of Water Supplies; Disposal of Garbage and Refuse; Animal Diseases and Animal Food; Demography and Statistics in their Sanitary Relation; Car Sanitation; Steamship and Steamboat Sanitation; The Etiology of Yellow Fever; The Relation of Forestry to Public Health; The Cause and Prevention of Infectious Diseases; Public Health Legislation; The Cause and Prevention of Infant Mortality; Transportation of Diseased Tissues by Mail; The Period during which each Contagious Disease is Transmissible and the Length of Time for which each Patient is Dangerous to the Community; Sanitation, with special reference to Drainage, Plumbing and Ventilation of Public and Private Buildings; International Arrangement for Protection against the Transmission of Infectious Diseases; Disinfectants; To Examine into the Existing Sanitary Municipal Organizations of the Countries belonging to the Association, with a view to Report upon those most Successful in Practical Results; The Duties and Responsibilities of the Healthy Man for his own and others' Health.

A CONFERENCE of representatives of the leading underwriting organizations was held in New York for the purpose of adopting a national code of rules governing the use of acetylene gas. It was generally agreed that the use of liquefied gas under pressure should be prohibited. There was a difference of opinion as to whether apparatus for the generation of acetylene should be allowed in insured buildings or whether separate buildings should be required.

A REMARKABLE discovery, as we learn from *Literature*, has recently been made in Dumbar-



tonshire, on the shores of the River Clyde, viz., an undoubted crannog, or dwelling on piles. It is about a mile east of Dumbarton Castle, is below high-water mark, and about 50 yards from the river at low tide. The circumference of the crannog is 184 feet. The outer circle is composed of piles of oak, sharpened by stone axes at the lower end, and below the mud still quite fresh. The transverse beams and pavements are of wood—willow, elder and oak, the smaller branches of fir, birch and hazel, with bracken, moss and chips. The refuse-mound extends about twelve feet outside, and in this have been found the bones of stags, cows, sheep, etc., together with evidences of fire, also numerous firestones and a hone or whetstone. Near the causeway a canoe, 37 feet long and 48-inch beam, was found, hollowed out of a single oak tree. The credit of the discovery is due to Mr. W. A. Donnelly, a keen local antiquary. It is a unique discovery (1) because it is the first example of a crannog situated on tidal waters, and (2) because only flint and bone implements have yet been discovered, and this dates it back into the Neolithic Age. All crannogs yet discovered have contained implements of bronze and other metals characteristic of the Bronze Age, so that this latest find seems at present to be the oldest crannog known.

PROFESSOR ROBERT H. THURSTON, of Cornell University, announces that Mr. P. T. Dodge, of New York, has presented to the museum of the Sibley College of Engineering what is probably, for its size, the costliest piece of machinery ever constructed. This is the Paige type-setting machine, the one in which Mark Twain sunk a lot of money. It consists of 19,000 pieces, controlled by a keyboard, and handles ordinary type, setting, justifying and distributing the matter, and leading it also, when required. It is believed to be one of the most beautifully ingenious pieces of mechanism as well as the costliest. The trouble with it commercially is that it is too ingenious, and, although perfect in the operation, cannot be built for sale. Of course, most of the two millions of dollars this, the original machine, is estimated to have cost, was used in the incessant changing and remaking in which years were spent. The machine occupies a floor space of

11½ x 3½ feet, and its highest point is 6½ feet from the floor. The weight is a little less than 5,500 pounds, and it runs without a perceptible vibration.

In a recent number of the *Berliner klinische Wochenschrift*, as quoted in the *British Medical Journal*, Professor Straussman gives an account of a visit to the Medico-Legal Institute of Bucharest. He says that the medical profession is treated with much greater respect there, and is given a higher and more independent position in the State than in any of our European cities. Professor Minovici, who is the Director of the Institute, is also Coroner and Director of the Morgue, where the bodies lie until identified; if not identified they are buried by order of the Director. The Institute itself is fitted up in the most elaborate manner; every detail has been carefully considered. A large lecture theatre is now being erected near the Institute for teaching purposes. The *post-mortem* room is large and well ventilated, and on the walls are hung diagrams of various parts of the body, which can be referred to when necessary. Bertillon's system of anthropometrical measurement is carried out. A bacteriological and chemical laboratory also forms part of the scheme.

A CORRESPONDENT of the *London Times* writes: A short time ago the London County Council addressed a communication to each of the vestries and district boards throughout the metropolis, asking them whether they would be in favor of the Council applying for Parliamentary powers to establish a bacteriological laboratory. The idea is to appoint an expert or experts in connection with the projected institution, or otherwise to make arrangements whereby medical officers of health and medical practitioners in London could obtain, at the expense of the county, the examination by a competent bacteriologist of material from suspected cases of infectious disease, with a view to aiding in the diagnosis. Owing to the summer vacation of the various local authorities the proposition has not yet been fully considered by the majority, but so far as those are concerned who have paid attention to the question the scheme has met with unanimous approval. Among those authorities who have

already pronounced in favor of the project may be mentioned the vestries of Shoreditch and St. Pancras. In the case of Shoreditch the health committee of the vestry point to the laboratory established by the city of New York some five years ago in connection with a scheme for general bacteriological examination of cases of diphtheria, and state that it has been received by the medical profession of that city with almost unanimous approval. The Shoreditch committee mention further that several towns in the provinces and some of the London sanitary authorities appear to have also made arrangements whereby medical practitioners can send pathological material to experts for bacteriological examination. Believing that it would be desirable in order to secure uniformity and economy that such provision should be made, the Shoreditch Vestry has just informed the County Council of its advocacy of such a laboratory. In St. Pancras the vestry has already made some progress in the direction indicated, since from a report just submitted to the health committee by Mr. John F. J. Sykes, medical officer of health, it appears the vestry early last year sanctioned the examination of pathological material in doubtful cases of diphtheria and typhoid fever, examinations being made when necessary. They are considered essential to the proper notification and prevention of the spread of the disease to which they apply. Two questions have to be considered: (1) whether it is more desirable to carry on the work locally or to centralize it; and (2) if centralized, which is the best method or public body for centralization. In this connection the health committee of the St. Pancras Vestry states that systems have been organized by the several sanitary authorities in conjunction either with the British Institute of Preventive Medicine, the Clinical Research Association or the bacteriologists of the large London hospitals. At the same time the small hospital laboratory at each of the large infectious diseases hospitals of the Metropolitan Asylum Board is utilized for the purpose of examinations of this nature. Taking all the points into consideration, the St. Pancras Vestry have come to the conclusion that a central bacteriological laboratory should be established, and

express the opinion that such an institution could be provided by the Metropolitan Asylums Board, under the latter's Parliamentary powers, in the new premises now being built on the Victoria embankment. A letter to this effect has this week been addressed to the County Council. As the London County Council does not meet until next month, and as the Vestries and District Boards are only now beginning to resume their proceedings, some little time will elapse before all the replies are in the possession of the Council. As these will not require much consideration it is possible that the Public Health Committee may be in a position to submit to the Council a recommendation on the subject early in November next.

#### UNIVERSITY AND EDUCATIONAL NEWS.

A VACANCY has occurred in the office of 'Assistant in Physiology' in the Harvard Medical School. The duties are to superintend the practical laboratory work of medical students, and to engage in original research. The salary is \$400. Applications with statement of qualifications should be made at once to Dr. H. P. Bowditch, 688 Boylston St., Boston, Mass.

THE University of Cincinnati has been presented with \$60,000 by Mr. Briggs S. Cunningham, a resident of Cincinnati and a member of the Board of Directors of the University. This money will be devoted to the erection of a building to be occupied by the departments of biology and of physics. Plans are being matured and it is hoped that the construction of the building, to be known as Cunningham Hall, will be begun within a month.

ACCORDING to the 'Cambridge University Calendar' for the year 1898-99, the total number of members of the University was last year 13,260, of whom 3,019 were undergraduates. This is an increase of 90 undergraduates over the preceding year. The most important changes in the scientific departments of the University have been the election of Mr. A. A. Kanthack to succeed the late Professor Roy in the chair of pathology; the appointment of Mr. George Griffiths as reader in surgery; the conversion of the University's lectureship of geology into a readership, and the establishment of a lectureship in chemical physiology not yet

filled. Among the minor University appointments during the past year were the following: Mr. Shaw, Emmanuel, Assistant Director of the Cavendish Laboratory; Mr. H. W. Pearson, Christ's, Assistant Curator of the Herbarium. To University lectureships—Mathematics, Mr. Love, St. John's; Midwifery, Mr. Stabb, Downing. The following have been appointed demonstrators: Mechanism and Applied Mechanics, Mr. Peace, Emmanuel; Animal Morphology, Mr. J. G. Kerr, Christ's; Botany, Mr. R. H. Biffin, Gonville and Caius; Pathology, Mr. T. Strangeways Pigg; teacher in Anthropology, Mr. Duckworth, Jesus.

THE chair in the medical department of the University of Pennsylvania, vacant by the death of Dr. William Pepper, will not be filled at present, it being recommended by the faculty that, for the present, Dr. James Tyson, professor of clinical medicine, be given full and general direction of the department of medicine, and that four assistants, Dr. John H. Musser, assistant professor of clinical medicine, Dr. Alfred Stengel, Dr. M. Howard Fussell and Dr. Frederick A. Packard, instructors in clinical medicine, be appointed to deliver, under Dr. Tyson's supervision, didactic lectures on medicine.

MISS AGNES M. CLAYPOLE, PH.B., Buchtell College and M. S., Cornell University, has been appointed assistant in microscopy, histology and embryology at Cornell University.

SECRETARY LONG has directed that the course in naval architecture begun at the Naval Academy at Annapolis last year under the now famous Constructor Hobson be transferred to the Massachusetts Institute of Technology. The course will cover a period of three years, including practical instruction in the summer in ship yards and navy-yards. Eight cadets will be detailed to take the course.

MR. FRANK IRVING SHEPHERD, recently acting professor of chemistry and physics in the University of Denver, has been appointed instructor in chemistry in the University of Cincinnati; and Dr. Thomas Evans, formerly instructor in organic chemistry at the Massachusetts Institute of Technology, and more recently chief chemist of the Proctor & Gamble Soap Company and of the American Cotton Oil Com-

pany, has been appointed instructor in technical chemistry at the University of Cincinnati.

PROFESSOR HOFER, of the University at Munich, has been appointed professor of geography in the University at Würzburg. Dr. Loewenherz has been qualified as docent in physics in the University at Königsberg.

#### DISCUSSION AND CORRESPONDENCE.

##### THE WINDMILL ILLUSION.

IN the issue of SCIENCE for September 16th Dr. F. C. Kenyon calls attention to the optical illusion to be seen when viewing a rotating electric fan, and requests some explanation of the same. The illusion consists in the apparently capacious reversal of the direction of rotation, and in a corresponding change of the plane of rotation.

This phenomenon has long been known to those who have investigated illusions of motion. So far as the writer's knowledge goes, it was first mentioned in literature in 1860, by the German Sinstedden.\* Since that time frequent mention has been made of it and several explanations have been propounded. The essentials of the illusion can be seen in the case of windmills, electric fans, rotating bars, or rotating disks bearing heavy radial strips of black. For all of these the name of 'The Windmill Illusion' is currently employed.

The explanation of the illusion is obviously to be sought in the interpretation of equivocal factors entering into the total experience known as the perception of rotation. Sinstedden, and Helmholtz after him, tried to explain the matter along this line. That *eye-movements* do not enter in has been shown by experiments reported by Dr. Nichols at the first meeting of the American Psychological Association. The essence of the explanation lies in the consideration that the perception of rotation often rests upon the perception of distinct positions of the rotating body, and that the succession of these various positions or phases of rotation admits of either of two interpretations as regards the direction of rotation. That we do perceive motion by means of its phases may be readily demonstrated by rotating a disk bearing variously colored sectors in a dark

\* Poggendorff's *Annalen*, CXL, 336.



room, the illumination being furnished by the electric spark. The rotation of the disk will seem to be now in one direction, now in the other, according as any sector, made visible by the instantaneous flash, is seen to occupy a position on this or that side of the sector seen just previously. If in addition any perceived phase could admit of a double interpretation we should have the illusion in question.

The reason for the illusion may, perhaps, be seen in this way. Faucy, for example, a narrow pennant floating from a staff, the observer being so placed that the line of direction of the pennant shall make an angle of, say,  $30^\circ$  with the plane passing through the observer and the staff. Further, let the pennant droop somewhat from the horizontal. If, now, this be viewed from a sufficient distance and by a somewhat dim light, it will prove impossible to determine absolutely whether the pennant is floating towards or away from the observer. That is, we have here a simple case of equivocal interpretation. The same double interpretation is true for every pair of positions between those just considered and the point where the pennant is perpendicular to the plane above mentioned. Suppose now that the pennant be made to rotate about the staff, occupying successively each of these positions. Manifestly the direction of rotation can not now be determined with full satisfaction, for since each of the phases seen was capable of a double interpretation, their succession must give rise to a possible perception of rotation in either of two directions, either from a position more remote to one nearer, or *vice versa*. Probably one direction will always be selected as *real* over against the other as illusory, for there are usually some subordinate factors that are dimly perceived which admit of only a single meaning.

Here then we have a type of the illusion. Now let the pennant be replaced by the vanes of a windmill or by the blades of an electric fan, and we find further equivocal factors present. Take the latter case. Not only the direction of the rotation, but the *slope of the blades* as well may be perceived in two ways. For the patches of light and shade, on the basis of which the slope is perceived, are also equivocal, and the particular illusory perception that we

get, not only of the *direction*, but also of the *plane* of the rotation, depends upon the special combination of these two equivocal factors. The whole matter is then at bottom one of the perspective interpretation of successive perceptions of light and color in their various combinations.

The above explanation is strongly substantiated by the universally observed fact that the rotating object must be viewed at a certain distance or by a dim light. That is, certain details which admit of but one meaning must be suppressed before the illusion can arise. Again, the fact that the illusion is at its best when the rotating object is viewed very *obliquely* makes for the explanation given. For here perspective interpretation is given full play. This oblique position of the observer is, however, not necessary in every case, for the writer has repeatedly seen the illusion when viewing a four-vaned windmill directly *en face*. Further, this explanation is strengthened by the fact that the illusion is most clear when one eye is covered.

Which one of the rotations shall in any given case be seen, when either is equally possible, will depend probably upon the position of the eyes. This is influential in all equivocal perceptions, and, as Wundt has pointed out, the law seems to be that the point fixated appears nearest to the observer.

Attention may be called here to a somewhat similar illusion mentioned by Silvanus P. Thompson in the *Quarterly Journal of Science* for 1879. If a crow be seen at dusk flying low against the sky the wings, seen alternately above and below, give the appearance of a single wing rotating about the crow's body like the blade of a screw propeller about its axis. The points of similarity between this and the Windmill Illusion are manifest.

A. H. PIERCE.

AMHERST COLLEGE.

MR. KENYON'S optical illusion described in your issue of September 16th may be best explained by another illusion with which I have been long familiar.

Take an ordinary glass goblet, tilt it a little from you, so that the farther rim is seen

through the glass. Shut one eye so as to get rid of binocular perspective.

You can now at will change the relative position of the two parts of the rim. At one moment you see the farther rim through the glass in its true position; at another it seems the nearer of the two and you seem to be looking into the mouth of the goblet.

Now, if the glass were rotating, it is evident that it would seem to rotate in the one direction or the other, according as we imagined the real or the reversed position of the rims.

The phenomena can be seen with both eyes open, but is clearer with one eye shut for the reason already given.

Now, I think the phenomenon of the rotating fan is explained in a similar way. The observer, I suppose, looked at the fan from a little *below* the horizontal, but seemed to be looking at it from *above*, when the rotation was apparently reversed.

JOSEPH LECONTE.

BERKELEY, CAL., September 24, 1898.

[A similar explanation has been sent us by Mr. Garrett P. Serviss, Jr. It is the explanation of Sinsteden, who first described the phenomenon in 1860, as stated above by Mr. Pierce. Cf. von Helmholtz, *Physiol. Optik.*, 1895, p. 770.—ED. SCIENCE.]

#### SCIENTIFIC LITERATURE.

*Memoirs from the Biological Laboratory of the Johns Hopkins University*, IV., 1. *The Cubomedusæ*.

A Dissertation presented for the Degree of Doctor of Philosophy, in the Johns Hopkins University, 1897. By FRANKLIN STORY CONANT. A Memorial Volume. Baltimore. 1898.

The late Dr. Conant, it will be recalled by many, was a member of the marine laboratory of the Johns Hopkins University, stationed during the summer of 1897 at Port Antonio, Jamaica. Toward the end of the season's work fever broke out. The director of the expedition, Dr. J. E. Humphrey, died in a sudden and alarming manner. Dr. Conant assumed charge of the laboratory, and, though aware of his own great danger, remained in Port Antonio, devoting himself to the service of others who needed his help. This generous subordination

of self cost him his life, for he contracted the fever, and, though able to reach this country, he died a few days after his arrival in Boston.

Dr. Conant's many friends, well aware of his candid, judicial mind, his keenness and persistency in observing and in reasoning from observations to a conclusion, have entertained the highest expectations of the work he was to do in science. Cut off at the beginning of his career, he leaves behind him several smaller papers and the dissertation before us. On closing this volume the author's friends will feel confirmed in their high opinion of his abilities, and those who did not know Dr. Conant will realize with regret that an able and conscientious naturalist has been removed from our midst.

Dr. Conant's dissertation, published as a memorial volume by his friends, fellow students and instructors, with the aid of the university in which he had recently taken his doctor's degree, deals with the anatomy and classification of one of the most interesting groups of jellyfish, the Cubomedusæ. In this group, embracing but a small number of species, the scyphomedusan structure, with which most of us are chiefly familiar through the study of *Aurelia*, *Cyanea* or *Dactylometra*, is in general presented as destitute of the complications which characterize the more common forms. This simplicity in general structure places the group close to the stem-forms, *Tessera* and *Lucernaria*, themselves scarcely more than sexually ripe *Scyphistomas*, and makes a comparison with existing Actinozoa an easy matter. Curiously enough, the members of this primitive group possess the most highly developed sense-organs as yet described among coelenterates, the nervous system being correspondingly differentiated. In one other respect the Cubomedusæ are unique, in that they alone among the Scyphomedusæ possess a velum. The phylogenetic origin of this velum (velarium) has been the subject of some discussion, the balance of opinion inclining to the belief that it has arisen through the fusion of marginal lobes similar to those found in the Peromedusæ and the Ephyropsidæ (*Nausithoë*), and is merely analogous to, not homologous with, the velum of the Hydromedusæ. That this is the case is borne out by the presence in the velum of gastrovascular diverticula. This

resemblance to the Hydromedusæ is regarded by most naturalists as one of the numerous cases of convergent evolution exhibited by the two groups of jelly-fish (Hydro- and Scyphomedusæ), due to similarity in environment and to a certain similarity in the ancestral polyps from which the two groups have been derived.

The Cubomedusæ are so rare that in spite of their interesting features, interesting alike to the student of phylogeny and nerve-physiology, few naturalists have had the opportunity of studying them. Our knowledge of the group has rested mainly on Claus's description of *Charybdea marsupialis* (Wien. Arb. 1878). This very valuable paper, as Conant remarks, is written in a style difficult of comprehension, and many students who read with pleasure and profit the lucid treatises on medusan structure by the Hertwigs and Haeckel have turned away discouraged from Claus's work. To Claus's account, Haeckel in his 'System' has added but little. The only other investigator of the group is Schewiakoff (1889), who has studied the remarkable sense organs.

Through Conant's discovery in 1896 of two new species (*Charybdea Xaymacana* and *Tripedalia cystophora*), which are present in abundance in Jamaican waters, the Marine Laboratory of the Johns Hopkins University has once again made accessible to students, material for the pursuit of investigations of wide interest. It was for the purpose of continuing his study of this group that Conant, in the summer of 1897, revisited Jamaica, and, as we learn from Professor Brooks's introduction, he succeeded in making many observations on the physiology of the sense-organs and on the embryology. His notes and material, we are told, are in such shape that they can be handed over to some one else, and it may be safely predicted that a valuable contribution to science will be the outcome of the last summer's work of this talented young naturalist.

The account of the subomedusa structure given by Dr. Conant is succinct, but comprehensive. The deep, four-sided bell bears a tentacle (or in some species a bunch of tentacles) at each angle. On each lateral surface, at a higher level than the tentacles, is situated a niche into which projects a sense-organ. The

primitively undivided (Scyphistoma condition) gastrovascular space is here differentiated into a central stomach and a peripheral portion lying in the lateral wall of the bell. The peripheral portion is subdivided into four stomach pockets by linear partitions, lying in the plane of the tentacles and therefore interradial. These partitions (cathammæ) are mere strips of entodermal lamella, produced by the fusion between the entodermal linings of ex- and sub-umbrella. The cathammal lines stop short of the tentacles, leaving an undivided peripheral portion of the primitive space, by means of which the four stomach pockets communicate with one another. As Conant points out, the arrangement recalls the gastrovascular system of many Hydromedusæ, with the difference that in the Cubomedusæ the radial canals are wide 'stomach pockets' and the cathammal plates are narrow lines. When we come, however, to the extreme peripheral portion of the gastrovascular system, we find that the likeness is not with the Hydromedusæ, but with the lobed Scyphomedusæ. The gastrovascular space, to be brief, does not end with an even circular edge at the bell margin, as is the rule in the former group, but is divided into separate lobes (marginal pockets) extending into the velum (as velar canals). Conant does not dwell on phylogenetic inferences, but evidently inclines to the belief that the ancestors of the Cubomedusæ possessed a margin divided into sixteen lobes. The present position of the four sense organs indicates the site of the original margin, "which elsewhere has grown down and away from its former level, leaving the sensory clubs like floatage stranded at high-water mark." Fusion between adjacent lobes, involving the ectoderm and jelly, gave to the medusa a continuous margin and a 'velum,' but, owing to the incompleteness in the fusion of the *entodermal linings* of the several lobes, the latter still retain in the adult Cubomedusa enough of their individuality to indicate their former condition. In a word, the marginal pockets of the existing Cubomedusa are to be construed as entodermal linings of once separate lobes.

This conclusion as to the morphology of the marginal pockets derives much support from the behavior of a puzzling structure, called by



Conant the marginal lamella. Unlike the true vascular lamella, which simply connects one entodermal cavity with another, the marginal lamella extends from the ectoderm of the gastrovascular space to the ectoderm of the bell margin. It is a narrow strip which follows the outline of the marginal pockets, traveling in the radii of the sense organs far away from the actual edge of the bell, and surrounding the sense organs in such a way as to indicate clearly that they were once at the bell margin. The marginal lamella seems to be a functionless, rudimentary organ. Claus, whose imperfect description of the structure did not bring to light its morphological interest, as indicating the site of the ancestral bell margin, suggested that it was perhaps the vestige of a ring canal. Conant naturally is skeptical of this explanation of a lamella connecting ento- and ectoderm. The true meaning of this peculiar lamella is a point well worth working up, more especially as it is not confined to the Cubomedusæ, but has been observed in the ephyra lobes of discophores (*Rhizostoma*).

Before leaving this subject of the general body-plan, it may be mentioned that while the probability is that the Cubomedusæ are descended from stalked ancestors (*Luceruarita*-like forms), and hence that the apex of the exumbrella was once drawn out into a peduncle, there is in the adult Cubomedusa no trace externally nor internally of this hypothetical stalked condition. Light on this very interesting point can only be expected from a study of the development.

Unlike the other Scyphomedusæ studied, the Cubomedusæ possess a nerve ring. In their study of the nervous system Claus and Conant both depended on sections, and naturally the results are not so satisfactory as those reached by the Hertwigs on the Hydromedusæ mainly with the aid of macerations. Claus describes the neuro-epithelium as consisting of alternating supporting cells and sensory cells, the inner ends of the latter becoming continuous with the nerve fibres. Conant makes it doubtful whether this is the actual condition, since he does not find the sensory cells. He offers, however, no observations on the origin of the 'nerve fibres.' Macerations will probably show the connection

of these fibres with at least some of the neuro-epithelium cells.

The possession of a nerve ring has been regarded (Claus) as a point of essential similarity between the Cubomedusæ and the Craspedota. The main ring in the former group is obviously a differentiation of the subumbrellar epithelium, and Claus, therefore, interprets it as homologous with the inner Craspedote ring. In the immediate neighborhood of each sense organ there are given off from the main ring two roots which *ceasing to be superficial bands* pass through the jelly, and emerge on the outer wall of the bell (on the floor of the sensory niche). They converge and unite, forming a superficial nerve tract which crosses the base of the sense-club. These four isolated tracts are regarded by Claus as the remnants of a once continuous exumbrellar ring, such as is found in the Hydromedusæ, and which here, as in the Hydromedusæ, stands in connection with the subumbrellar ring though the medium of fibres that perforate the jelly. Conant, on the other hand, regards the tracts lying across the bases of the sense organs as portions of the primitive subumbrellar ring which were shut off from the main ring, when the marginal lobes grew together. With the Hertwigs and Haeckel he thus looks on the ring as not homologous with that of the Craspedota, but as a special differentiation of the subumbrellar plexus found throughout the Scyphomedusæ.

The sense organs of the Cubomedusæ are 'sense-clubs,' or modified tentacles. In addition to the crystalline sac, the expanded head of the club bears six eyes. Four of these are simple, but two are complex organs provided with a cellular lens and cornea, a vitreous body behind the lens, and a retina. These eyes look into the bell cavity. It is especially in reference to the structure of the retina and vitreous body of the complex eyes, that Conant's conclusions differ from those of Schewiakoff. The vitreous body Conant finds is not a homogeneous structure, but is composed of prisms of refracting substance. The retina does not show the two types of cells (sensory and pigmented) distinguished by Schewiakoff. Conant's results in this matter of the retinal structure are in some respects negative. The points still to be

cleared up are as in the case of the nerve cord, such as will require the free use of macerations and surface preparations of fresh tissue.

H. V. WILSON.

#### SCIENTIFIC JOURNALS.

*The American Journal of Science* for October opens with an important article by Professor C. Barus, describing experiments on the impenetrability of colloids. The author points out that as with gelatine the same body may manifest itself both as a liquid and a solid, so the same ether may act, as the case may be, either as a liquid or as a solid. Professor C. E. Beecher concludes his series of articles on the origin and significance of spines. He has shown that spinose forms were all derived from non-spinose ancestors, and were simple and inornate during their young stages. Spines represent an extreme of superficial differentiation and out of spinose types no new types are developed. Director Chas D. Walcott writes on the brachiopod fauna of the quartzitic pebbles of the Carboniferous conglomerates of the Narragansett Basin and Rhode Island. The number also includes articles on the eolian origin of loess, by C. R. Keyes; on dikes of felsophyre and basalt in Paleozoic rocks in central Appalachian Virginia, by N. H. Darton and A. Keith; on diaphorite from Montana and Mexico, by L. J. Spencer; on the detection of sulphides, sulphates, sulphites and thiosulphates in the presence of each other, by P. E. Browning and E. Howe, and on twinned crystals of zircon from North Carolina, by W. E. Hidden and J. H. Pratt.

*The American Naturalist* for September publishes the Vice-Presidential addresses at Boston of Professors Packard and Farlow and contains in addition an article by Mr. E. O. Hovey, describing the museums he visited last year when in Europe attending the International Geological Congress. Special attention is paid to geology, mineralogy and paleontology.

PROFESSOR H. POINCARÉ, of the University of Paris, contributes to the October *Monist* an article 'On the Foundations of Geometry,' in which he considers the questions of the origin of space and the feeling of direction, of the

classification of displacements, of the properties of groups and sub-groups, of continuity and discontinuity, of the notion of point and number of dimensions, etc. In the same number Professor Ernst Schroeder, of Karlsruhe, has an article 'On Pasigraphy,' in which he sums up the history of the movement, and briefly characterizes the present state of research in this department. Dr. Topinard concludes his series, 'Science and Faith,' with an article on 'The Social Problem,' in which he outlines a plan for the rehabilitation of society by systematic interference with the workings of so-called 'natural' evolution.

*The Educational Review* for October contains the following articles: 'The Public Education Association of New York,' by Mrs. S. Van Rensselaer; 'Study of Education at the German Universities,' by Walter L. Hervey; 'Herbartian Philosophy and Educational Theory,' by Arnold Thompkins; 'Why College Graduates are Deficient in English,' by Annie E. P. Searing; 'The New Jersey System of Public Instruction,' by James M. Green, and 'What Modern Philosophy Offers Secondary Education,' by O. L. Manchester and H. H. Manchester.

#### NEW BOOKS.

- Thermodynamics of the Steam-engine and other Heat-engines.* CECIL H. PEABODY. New York, John Wiley & Sons; London, Chapman & Hall, Ltd. 1898. 4th Edition. Rewritten and Reset. Pp. iv + 522. \$5.00.
- The Discharge of Electricity through Gases.* J. J. THOMSON. New York, Charles Scribner's Sons. 1898. Pp. x + 203. \$1.00.
- Theories of the Will in the History of Philosophy.* ARCHIBALD ALEXANDER. New York, Charles Scribner's Sons. 1898. Pp. viii + 357. \$1.50.
- Four-footed Americans and Their Kin.* MABEL OSGOOD WRIGHT. Edited by FRANK M. CHAPMAN. New York and London, The Macmillan Company. 1898. Pp. xii + 432.
- Differential and Integral Calculus.* P. A. LAMBERT. New York and London, The Macmillan Company. 1898. Pp. x + 245. \$1.50.
- An Introductory Logic.* JAMES EDWARD CREIGHTON. New York and London, The Macmillan Company. 1898. Pp. xiv + 392. \$1.10.

# SCIENCE

EDITORIAL COMMITTEE: S. NEWCOMB, Mathematics; R. S. WOODWARD, Mechanics; E. C. PICKERING Astronomy; T. C. MENDENHALL, Physics; R. H. THURSTON, Engineering; IRA REMSEN, Chemistry; J. LE CONTE, Geology; W. M. DAVIS, Physiography; O. C. MARSH, Paleontology; W. K. BROOKS, C. HART MERRIAM, Zoology; S. H. SCUDDER, Entomology; C. E. BESSEY, N. L. BRITTON, Botany; HENRY F. OSBORN, General Biology; C. S. MINOR, Embryology, Histology; H. P. BOWDITCH, Physiology; J. S. BILLINGS, Hygiene; J. MCKEEN CATTELL, Psychology; DANIEL G. BRINTON, J. W. POWELL, Anthropology.

FRIDAY, OCTOBER 14, 1898.

## CONTENTS:

<i>A New Gas</i> : CHARLES F. BRUSH.....	485
<i>The New York State College of Forestry</i> : PROFESSOR B. E. FERNOW .....	494
<i>Geology and Geography at the American Association Meeting (II)</i> : WARREN UPHAM.....	501
<i>Notes on Inorganic Chemistry</i> : J. L. H.....	506
<i>Current Notes on Meteorology</i> :—	
<i>The Mean Annual Rainfall of the Globe</i> ; SYMONS' <i>British Rainfall</i> ; Notes: R. DEC. WARD.....	507
<i>Current Notes on Anthropology</i> :—	
<i>'On Inspiration'</i> ; <i>Relics from the Uloa Valley</i> : PROFESSOR D. G. BRINTON .....	508
<i>Scientific Notes and News</i> .....	508
<i>University and Educational News</i> .....	512
<i>Discussion and Correspondence</i> :—	
<i>The Method of Types</i> : O. F. COOK. <i>The Supposed Bipolarity of Polar Faunas</i> : DR. ARNOLD E. ORTMANN.....	513
<i>Scientific Literature</i> :—	
<i>Hertwig on Die Zelle und die Gewebe</i> : PROFESSOR FRANK R. LILLIE. <i>Mills on Animal Intelligence</i> : DR. EDWARD L. THORNDIKE.....	517

MSS. intended for publication and books, etc., intended for review should be sent to the responsible editor, Professor J. McKeen Cattell, Garrison-on-Hudson, N. Y.

## A NEW GAS.\*

THE purpose of this purely preliminary paper is to announce the discovery of a new gas, presumably elementary, and possessed of some extraordinary properties. It is a constituent of the atmosphere and is occluded by many substances. Its chief

\* Read before the American Association for the Advancement of Science, August 23, 1898.

characteristic thus far ascertained is enormous heat conductivity at low pressures. In order to appreciate this phenomenon it is necessary to consider the heat conductivity of some of the well-known gases.

A year ago I had the honor to read before this Section a paper on the transmission of heat by gases, illustrated by numerous curve sheets showing the heat conductivity of several gases at all pressures from atmospheric down to the best vacuum obtainable; also an allied paper on the measurement of small gaseous pressures. Abstracts of these papers appear in the current volume of Transactions, and their full text may be found in the *Philosophical Magazine* for January, 1898, and November, 1897, respectively.

The apparatus used for the described experiments in heat transmission consisted in part of a long-stemmed thermometer hanging in a long-necked glass bulb, the bulb of the thermometer being in the center of the glass bulb. Two bulbs were used for different experiments; the larger one 112 mm. in diameter, the smaller one only 20 mm. A tank of water and crushed ice under the bulb was adapted to be raised when desired, so as to immerse the bulb in the cold mixture. The neck of the bulb was connected with an air pump capable of reducing the internal pressure to a very small fraction of a millionth of atmospheric pressure; also with an elaborate pressure



gauge adapted to measure small pressures with very great precision, and a barometric gauge for measuring larger pressures.

In using this apparatus the gas to be tested was introduced at atmospheric pressure; the ice tank was raised, and the falling temperature of the thermometer, which could lose heat only by radiation, conduction and convection through the surrounding gas, was observed through a telescope. The time required for the temperature to fall through a given range, usually from  $15^{\circ}$  to  $10^{\circ}$  Centigrade, was carefully noted. Then the ice tank was lowered, permitting the thermometer to regain the temperature of the laboratory; some of the gas was pumped out, and the cooling of the thermometer again observed at this reduced pressure. This process was repeated many times, until the pressure was reduced to the lowest point attainable.

The results obtained with each gas were plotted in a curve showing its heat conductivity at all pressures from atmospheric down; the ordinates representing the reciprocals of the time of cooling in seconds, while the abscissas represented the pressure.

The present chart shows curves representing the heat conductivity of several gases, from fifty millionths of atmospheric pressure downward. The data for all of these, except the helium curve, are taken from last year's paper; but the scale is different.

I am indebted to Professor Ramsay for the helium used in obtaining the curve here shown.

The ordinates of each curve measured from A B as a base line represent the total rate of heat transmission by the ether and the gas at the pressures indicated by the abscissas, while ordinates measured from the line C D represent the heat transmitted by the gas alone.

It will be observed that the curves of all the gases named vanish together at the

point of zero pressure D. Repeated experiments have shown this condition to be always strictly true within the narrow limits of errors of observation, provided that, before the introduction of the gas to be tested, the whole apparatus has been kept highly exhausted for several days; or, better still, has been heated several hours by means of air and water baths, while kept exhausted. Without one of these precautions I was never able to get any gas curve quite down to the point D, for reasons which will appear. The point D represents a period of three hundred seconds required for the temperature of the thermometer to fall from  $15^{\circ}$  to  $10^{\circ}$ , with the pressure of the surrounding gas reduced to one twenty-millionth or less.

A very brief account of the circumstances which led to the discovery of the new gas may not be out of place. I had long been engaged in high vacua experiments, and had observed that glass apparatus, when highly exhausted and heated, evolved gas for an indefinite length of time, rapidly at first, then slower, but never stopping until the temperature was reduced. On cooling, rapid reabsorption always took place, but was never complete; indicating that two or more gases had been evolved by heating, one of which was not absorbed by cooling. In other words, the absorption was selective. The truth of this conclusion was abundantly demonstrated subsequently. However, the percentage of reabsorbed gas was so large that I used a small quantity of pulverized glass in several experiments to absorb a part of the residual gas after the highest attainable exhaustion was reached. The pulverized glass was always lead glass like that of the apparatus, and was heated nearly red-hot for several hours before and during the final exhaustion.

During these experiments a curious phenomenon was noted—the pulverized glass lost its snowy whiteness. This I thought

must be due to reduction of some of its glass; and its presence in the glass, if lead, probably by hydrogen evolved on proved, would be a long step toward prov-

Chart Showing Relative Heat Conductivity of Gases.

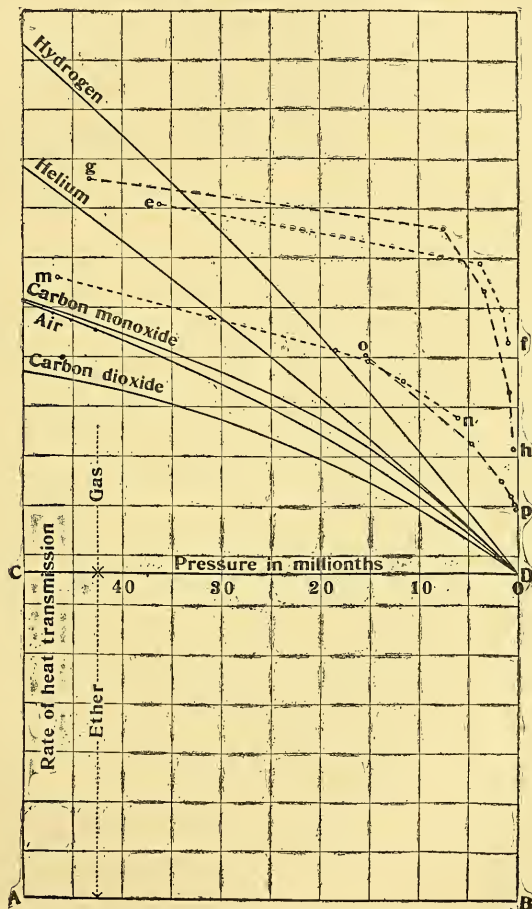

heating. If so, I argued that the hydrogen must have been absorbed from the atmosphere since the manufacture of the

ing the normal presence of hydrogen in the atmosphere.

Following the line of experiment thus

suggested, I prepared a quantity of pulverized soda glass free from lead and placed about 120 grams of it in a large combustion tube connected with the apparatus already described. The glass was made from an old stock of tubing, and was of such a degree of fineness that it all passed through a sieve of 90 meshes to the linear inch, but would not pass through a 140-mesh sieve. The combustion tube was adapted to be heated by a gas furnace with automatically regulated gas supply, so as to be maintained at any desired temperature.

While prepared to make analysis, in the usual way, of the gas evolved by the pulverized glass in case it appeared in sufficient quantity, I relied chiefly on its heat conductivity for the detection of any large proportion of hydrogen in the last few millionths, not being prepared at that time for spectroscopic examination; and thinking that, perhaps, some hydrogen might be evolved in the last stages of exhaustion before heating, I tested the conductivity of the residual air from time to time as the preliminary exhaustion progressed.

When the exhaustion approached a good vacuum an astounding phenomenon developed. At 36 millionths pressure the residual gas conducted heat twice as well as air, and nearly as well as hydrogen; at 3.8 millionths it conducted seven times as rapidly as hydrogen; at 1.6 millionths, fourteen times, and at .96 of one millionth, twenty times as rapidly. These results are plotted in the curve *e f*. I did not carry the exhaustion lower than .96 M. At this pressure the time of cooling of the thermometer from 15° to 10° was only 177 seconds, while pure hydrogen would have required 288 seconds.

Evidently a new gas of enormous heat conducting capacity was present, mixed with the last small portion of air. It must have come from the pulverized glass, and

probably formed only a small fraction of the mixture. The last cc. of gas pumped out was collected, and upon subsequent analysis of it nothing but air was found.

The discovery of the new gas, as above outlined, was made nearly a year and a half ago, on March 10, 1897. On the following day the pressure had increased to nearly five millionths; while the time of cooling of the thermometer, instead of diminishing as usual with increase of pressure, had raised from 177 seconds to 245 seconds, showing that the new gas had largely disappeared. This was subsequently found to be due to absorption by the phosphorus pentoxide used in desiccation.

Long continued moderate heating of the pulverized glass caused the evolution of some air, much carbon dioxide and hydrogen, some carbon monoxide, and more of the new gas. The selective absorption which occurred on cooling was confined almost wholly to the hydrogen and new gas. After further moderate heating and thorough exhaustion, I raised the temperature, continued the exhaustion, and got the results embodied in the curve *g h*, showing that much of the new gas was present; the conductivity at .38 millionth, the last station in the curve, being *twenty-seven times* that of hydrogen. Several days of high heating, with frequent exhaustion, failed to wholly deprive the pulverized glass of its new gas, though the output was greatly diminished. For this and other reasons, I believe that the new gas resides *in* and not simply on the surface of glass.

To make sure that the apparatus was not deceiving me, I sealed off the combustion tube, heated the vacuous parts several hours by means of air and water baths as before indicated, admitted air dried over phosphorus pentoxide, exhausted step by step, and got the data for the 'small-bulb' air curve shown here and in last year's paper. Evidently I had not been deceived



about the presence of a new gas in the pulverized glass. I subsequently exposed this lot of glass several days to the atmosphere, spread out in a thin layer. When tested again after this exposure it yielded the new gas, both before and after heating, as freely as at first. This rejuvenation of pulverized glass by exposure to the air was fully confirmed with another lot made from common window glass, and in connection with the results obtained by the diffusion of air, hereafter described, leaves no room for doubt that the new gas is a constituent of the atmosphere.

Pulverized glass appears to begin evolution of the new gas as soon as the atmospheric pressure is reduced. In one case, while making a slow preliminary exhaustion, I tested the air which remained when the pressure was still 132 mm., and, to my great surprise, found it contained not only a trace, but a considerable quantity of new gas. The amount increased rapidly as the pressure was further reduced. This leads to the belief that finely pulverized glass gives up the greater part of its new gas on simple reduction of pressure to a low point, and without heating; somewhat as palladium gives up occluded hydrogen.

Several substances other than glass were examined, and nearly all found to contain the new gas. A specimen of old charcoal made from pine-wood sawdust by long exposure to a bright red heat yielded as was expected, comparatively large quantities of several gases when heated in vacuum. At some stages of the evolution these were rich in the new gas.

It would seem easy in such cases to remove the diluent gases by oxidation and absorption; but it is not. After making the necessary additions to my apparatus, I made many attempts of this kind. The reagents used were in large excess on account of the very small quantities of gas treated; so that some of the observed re-

sults may have been due to impurities. Cupric oxide and lead chromate evolved gases of their own almost indefinitely on high heating in vacuum, and then freely absorbed carbon dioxide and moisture at a lower temperature. Soda-lime dried in vacuum in presence of phosphorus pentoxide was almost indifferent to carbon dioxide. All the reagents named, especially phosphorus pentoxide, absorbed the new gas; and all but the latter give it up again on heating.

A specimen of very fine white silicious sand, when heated in vacuum, gave a large quantity of gas consisting principally of hydrogen and hydrocarbons, with a considerable amount of the new gas. Some of this mixture was exposed successively to the action of red-hot cupric oxide, soda-lime and phosphorus pentoxide. By this treatment the gases were reduced to less than three per cent. of their former volume. The residue was not very rich in the new gas, because of the absorption of the latter by the soda-lime and phosphorus pentoxide, as I afterwards learned; but I have shown the curve *op* of its heat conductivity, because the pressure was carried to a lower point than in any other case. At the last station in the curve, representing a pressure of .12 of a millionth, the conductivity was equal to that of 5.1 millionths, or forty-two times as much hydrogen. From this it seems reasonably certain that the curve *ef*, if carried to as low a pressure, would have shown a conductivity at least a hundred times greater than hydrogen. And yet the new gas in that experiment must have been very far from pure on account of the continuous evolution of ordinary gases, as shown by the rise of pressure and loss of conductivity during the next few hours.

It will be observed that when the new gas was present the form of the conductivity curves was very different from those of the known gases, the effect of the new

gas becoming more prominent as the pressure was reduced. I do not doubt that this was due to the interference of the heavier and slower moving molecules of the ordinary gases always mixed with the new gas. In last year's paper I described the same effect found in a mixture of carbon dioxide and hydrogen. When the new gas is obtained in a state of purity I expect to find its curve of heat conductivity similar to those of hydrogen and helium, but with immensely increased ordinates.

Believing that the new gas is very much lighter than air or hydrogen, and may therefore be separated from the atmosphere by successive diffusions, I have spent several months in experiments with this end in view. Quite recently my efforts have been crowned with most promising success. The difficulty has been to find a suitable porous septum; one free from holes, and sufficiently fine-grained to prevent more than a very slow passage of air, while a considerable surface is exposed to the atmosphere on one side, and to a fairly good vacuum on the other. Many substances were tried. India-rubber gave encouraging results, but was capricious and very slow. The best results have been obtained with porous porcelain having its superficial pores nearly closed by suitable treatment. A tube of this kind, closed at one end, and exposing rather more than five square inches of surface to the air, was connected with the apparatus, and the whole kept exhausted to a pressure of 1.3 mm. About 19 cc. of gas was diffused per hour. After 36 hours the diffusion tube was shut off, the exhaustion continued, and data for the curve *mn* obtained. It was found impracticable to carry the exhaustion below six millionths, because of the presence of moisture, which interfered with the action of the pump, no desiccating agent being used. As both phosphorus pentoxide and soda-lime absorb the new gas they cannot be used for desic-

cation. If the exhaustion had been carried as far as in the curve *op* it is probable that a higher conductivity than in that curve would have been shown; *i. e.*, a conductivity more than 42 times that of hydrogen, or something like a hundred times that of air. Here we have the heat conductivity of air at very low pressure, increased something like a hundred-fold by one diffusion. I have not yet tried a secondary diffusion, but feel confident that successive diffusions of air will afford a practicable means of obtaining the new gas in a state of approximate purity.

Now let us discover, if possible, the meaning of the extraordinary heat conductivity of the new gas. I have tabulated the molecular weight, density, specific heat, mean molecular velocity and heat conductivity of hydrogen, helium, carbon monoxide, air and carbon dioxide, which are the known gases represented in the curve chart. For easy comparison, I have taken not only the density, but the specific heat, mean molecular velocity and heat conductivity of hydrogen as unity. The similarity of values in the fifth and sixth columns, for molecular velocity and heat conductivity, is striking. On the chart the curves for carbon monoxide, air and carbon dioxide are evidently too high to correspond well with the relative values of molecular velocity in the fifth column; but these curves represent only the last 50 millionths of the complete curves. By following these back to 500 millionths, which is still a rather small pressure, and taking their values at intervals of 10 millionths from no pressure upward, we obtain as a mean of all these values for each gas the quantities shown in the sixth column. These agree fairly well with the molecular velocities.

I offer the suggestion that the relatively high conductivity of the last three gases at the low pressure shown in the chart is due to the dissociation of some of their mole-

cules by unobstructed impact on the walls of the containing vessel; recombination being more and more retarded as the pressure is lessened, because the greater separation of the molecules reduces the frequency of collisions. Helium, perhaps because it is monatomic and therefore incapable of dissociation, has a nearly straight curve like hydrogen; and its ratio, given in the sixth column, varies but little throughout the

when mixed with a large proportion of other gases, is something like a hundred times that of hydrogen. I shall not be surprised to find the conductivity of the pure gas a thousand or more times greater than that of hydrogen; but let us be conservative, and for the present purpose call it a hundred times and see what follows. I have given it this value at the head of the sixth column.

Comparison of Gaseous Properties.

1	2	3	4	5	6
Gas	Molecular weight	Density D	Relative specific heat	Relative molecular velocity $\frac{1}{\sqrt{D}}$	Relative heat conductivity
Etherion	? 0.0002	? 0.0001	6000.?	100.?	100.
Hydrogen	2.	1.	1.	1.	1.
Helium	4.	2.	? .300	0.71	0.73
Carbon monoxide	27.8	13.9	0.072	0.27	0.33
Air	28.8	14.4	0.069	0.26	0.32
Carbon dioxide	48.8	21.9	0.064	0.21	0.21

whole range observed, which was more than a thousand millionths. I have taken the density of helium as 2, but Professor Ramsay finds it a little less than this when purified as far as possible by repeated diffusions. This makes its relative molecular velocity a little more than .71, and brings it still closer to the observed value of its heat conductivity.

From the foregoing, we may reasonably conclude that the heat conductivity of gases at low pressures, and their mean molecular velocities, are closely related. Hence, if we can learn the heat conductivity of an otherwise unknown gas we can form some idea of its mean molecular velocity; and from this, of its specific heat, density and molecular weight.

As before indicated, the heat conductivity of the new gas at very low pressure, even

If my inference that the heat conductivity and molecular velocity of gases are directly related is correct, then the molecular velocity of the new gas will be 100 times that of hydrogen, as shown at the head of the fifth column. As is well known, the mean molecular velocity of a gas varies directly with the square root of its absolute temperature, and is independent of pressure. The mean molecular velocity of hydrogen at the temperature of melting ice has been found by calculation to be 5,571 feet per second. Hence the mean molecular velocity of the new gas at the same temperature will be 557,100 feet, or more than 105 miles per second. At anything like this molecular velocity it would be quite impossible for a gas to remain in the atmosphere, *unless the space above also contained it*. A velocity of only about seven miles per second, if un-



checked except by gravitation, would be sufficient to project a body from the earth permanently into space. Even at a temperature very close to absolute zero the new gas would have sufficient molecular velocity to escape from the atmosphere.

Again, inasmuch as the molecular velocities of gases vary inversely as the square roots of their densities, it follows from our assumption of its molecular velocity that the density of the new gas is only the ten-thousandth part that of hydrogen, as shown at the head of column 3. This is the hundred and forty-four thousandth part the density of air. It is generally believed that the gases of the atmosphere distribute themselves in the long run, each as though the others were absent. Hence the new gas must extend a hundred and forty-four thousand times as high as the heavy constituents of the air to bring about the same proportionate reduction of pressure, even if gravitation remained constant at all distances from the earth; but the restraining influence of gravitation on the expansion of the atmosphere diminishes as the square of the distance from the earth's center increases.

It is evident, therefore, without a mathematical demonstration, that the new gas, being present in the atmosphere, must extend indefinitely into space without great loss of pressure. This is only another way of stating the result of its assumed molecular velocity. Now, there is no doubt that the new gas exists in the atmosphere, though probably in very small proportion, perhaps much less than a millionth. Hence it seems really probable that it not only extends far beyond the atmosphere, but fills all celestial space at a very small pressure. In recognition of this probability, I have provisionally named it ætherion, or etherion, meaning 'high in the heavens.' Its symbol will naturally be Et.

I am aware that strong objections may

well be raised to the hypothesis of an inter-planetary and inter-stellar atmosphere; but I can see no escape from the conclusion I have drawn, if I am not mistaken in my premises.

The estimated relative specific heat of etherion appears at the head of the fourth column, based again on the assumed relative molecular velocity. In estimating the specific heat, I have not made it inversely proportional to the density, as would be required by Dulong and Petit's law, giving a value ten thousand times that of hydrogen; but have used the formula suggested by Professor Risteen in his work on 'Molecules and the Molecular Theory,' which requires that the product of the specific heat and molecular weight of gases shall vary with the number of degrees of freedom of their molecules. I have assumed as probably true that etherion is monatomic, with atoms possessing only three degrees of freedom.

Of course, the values I have estimated for the molecular weight, density, specific heat and molecular velocity of etherion are intended only to indicate the *order* of magnitudes we may expect to find on further investigation; and it must not be forgotten that they are based on two assumptions: first, that the heat conductivity of etherion is 100 times that of hydrogen; and second, that the ratio of heat conductivity and mean molecular velocity is the same for all gases. As before indicated, I expect to find the heat conductivity of etherion much higher than the value here assigned to it. If so, the real value of its other attributes will be still more startling than those here given. The second assumption, while by no means proved, seems at least a good 'first approximation' to the relation between heat conductivity and molecular velocity in gases.

There is some evidence that etherion is a mixture of at least two different gases. In the course of my experiments I have met

with a great many specimens, obtained in various ways from various sources, but always mixed with a very large excess of other gases. Some specimens were almost wholly absorbed by the phosphorus pentoxide at first used for desiccation. Others were but partially absorbed; the absorption being very rapid at first, but in an hour or two dwindling to nothing, and leaving a residue of gases permanently showing, by their heat conductivity, the presence of a very considerable amount of etherion. Soda-lime absorbed etherion, but much less freely than phosphorus pentoxide, and gave it up again on heating. The gas thus recovered was but little, if at all, affected by phosphorus pentoxide.

In one experiment the gases evolved from ten ounces of pulverized window glass, both before and after heating, were passed through coarsely pulverized soda-lime and then over fresh phosphorus pentoxide. Not a trace of etherion remained. The same result was obtained when another lot of the silicious sand, already referred to, was used as the source of etherion.

I will venture the conjecture that etherion will be found to consist of a mixture of three or more gases, forming one or more periodic groups of new elements, all very much lighter than hydrogen. If this proves true I propose to retain the present name for the lightest one.

The transmission of radiant energy through space has always been to me a fascinating phenomenon, and I have indulged in much speculation concerning the ether—that mysterious something by means of which it is effected. The remarkable properties assigned to the ether from time to time, in order to account for observed phenomena, have excited my keen interest; but I have long entertained the hope that some simpler explanation of the mechanism involved will be found. To me, a less strain of the imagination is required in the

assumption that, instead of a continuous medium, gaseous molecules of some kind, endowed perhaps with a mode or modes of motion at present unknown to us, are the agent of transmission; a gas so subtle, and existing everywhere in such small quantity, that it has escaped detection.

Perhaps the molecular hypothesis of the ether has proved so attractive to me because it supports the hope that we may sometime compass the perfect vacuum—a portion of space devoid of *everything*. Such a vacuum would be opaque to light, and gravitative attraction could not, I believe, act through it. It might afford a new point of view from which to study the profound mystery of gravitation; an *outside* point.

The late De Volson Wood (*Phil. Mag.*, Nov., 1885) considered the question of a gaseous ether mathematically, and deduced certain necessary properties of the hypothetical gas; chief among which were exceedingly small density and exceedingly high specific heat. Possibly we are about to find a gas which will fulfil the required conditions. It may be etherion, or its lightest constituent if it turns out to be a mixture. I venture to express the hope that etherion will at least account for some phenomena at present attributed to the ether.

On account of the presumably extreme smallness of its molecules as compared with those of glass, etherion probably passes through the latter when any considerable difference of pressure exists on opposite sides; though the passage may be very slow. It seems to be condensed or compressed in glass as before indicated, and may evaporate on the side of lower pressure, and be absorbed on the side of higher pressure, after the manner of hydrogen in passing through palladium. In my own experiments the heat transmission ascribed to the ether may be due to the presence of the new

gas inside the bulb. A small fraction of a millionth would be sufficient, and this might escape detection by the pressure gauge, on account of the necessary compression in the gauge head causing absorption by the glass. Again, etherion must always be present to some extent in all 'vacuum tubes' (as well as in my own conduction bulb), on account of its long continued evolution from glass, and may be the medium of propagation of the Röntgen rays in the vacuum glass and air.

CHARLES F. BRUSH.

CLEVELAND, O.

THE NEW YORK STATE COLLEGE OF  
FORESTRY.\*

EVER since the American Forestry Association was formed at Cincinnati, in 1882, the need of providing for forestry education has been a favorite topic at the meetings. There were those who wished to make the subject a part of the studies in the public schools, and others who desired the establishment of special schools, either separate or in connection with other educational institutions.

Fortunately for our public schools and over-burdened school teachers, who are struggling not always quite successfully to do justice to their legitimate functions, the schemes of our enthusiastic forestry reformers in the first direction have not matured beyond the introduction of an Arbor Day celebration, perhaps an occasional reading or talk, quite sufficient to call the attention of the young mind to the existence and significance of the subject.

Those who had higher aims and expected that the existence of technically educated foresters would pave the way to the application of their art contemplated, in their philanthropic desires, the sacrifice of the individual to the cause; for unless the students issuing from such forestry schools

had other means of subsistence, their bread, if they could earn it, would hardly have been buttered through their knowledge of forestry.

It may be set down as an axiom that the employment of any specialist in a technical art comes, as a rule, when the economic conditions are ripe for such employment.

In the United States the exploitation of all resources has, as in every newly-settled country, been carried on without the technically educated specialist; until 1870 or thereabout mining engineers were a rarity, and the exploitation of the soil by agriculture has only just begun to be considered an art; agricultural rapine is still largely the practice, just as the natural resources of the forest are and will be still for some time the object of the lumberman's rapine.

When does the time for a change come? When does it become necessary to employ skill and art in the use of our resources? These are difficult questions to answer. In a general way, from the standpoint of the individual the answer can only be one, namely, 'when it pays;' a consideration of supply and market conditions determines for him when his financial interests are best subserved by the use of greater skill and knowledge. He may not always recognize the right moment, but it would be a profit calculation which would have to be employed to persuade him of its arrival.

From the standpoint of the community, the State, the financial consideration may be quite secondary; the interest in the preservation of certain favorable conditions may justify an expenditure, a sacrifice of the present for the sake of the future.

It was the recognition that such an interest existed which induced the State of New York to take a first step with regard to her forest resources thirteen years ago by ceasing to dispose of the forest lands which the State had unwillingly acquired through

\* Read before the American Forestry Association at Boston, August, 1898.



non-payment of taxes by the owners. A further recognition of the importance of this interest followed two years ago by establishing the policy of land purchases for the increase of this area, under which policy one million dollars was expended last year and half a million is at the disposal of the Forest Preserve Board this year, while it is expected by further purchases to increase the State forest property to three million acres, more or less. This year a further, logical step in the pursuit of this State policy was made by establishing a forestry school for the professional education of the managers of this State property and an experimental forest area, in which the method of managing the property might be developed and elaborated.

This school, the New York State College of Forestry, has the distinction of being the first institution of its kind in this country where a professional study of the whole subject of forestry in all its phases may be pursued with opportunities almost equal to the best in European forestry schools, except for the absence of object lessons, which it will take some time to create.

Thus, while the art of forestry is as yet hardly practiced, a place for the study of the science, which must underlie the application of the art, is established; and this entails the moral obligation upon the State to proceed on its path to a technical management of its forest property.

We may recall that the original forestry law of New York, which was mainly drafted by the writer and passed in 1885, contemplated a technical forest management of the State property and hence conferred upon the then established Forest Commission the right to cut and sell wood.

But no professional foresters were employed and no technical forest management was attempted; the right to cut and sell was exercised simply in selling stumpage of spruce to lumbermen.

The public, laboring under the mistaken notion that forest preservation required cessation of all cutting of trees, and not trusting to the discretion of its officers—rightly or wrongly—attempted to remedy the absence of technical advice by inserting into the constitution of the State a clause which prevents all cutting of wood on State lands—a foolish provision from the forester's point of view, but perhaps, from the standpoint of expediency at the time, not entirely reprehensible.

It became apparent that, before a rational forest management could be secured, it was still necessary to educate the people first to a true conception of what that involves; that an object lesson was needed in order to show that forest preservation did not mean 'Woodman, spare that tree,' but 'Woodman, cut those trees judiciously;' in other words, that forest utilization and forest preservation by means of forest reproduction were not incompatible.

Imbued with this idea, the Superintendent of the reorganized or consolidated Fisheries, Game and Forest Commission, in his report for 1896, suggested the establishment of such a demonstration of technical forest management.

Governor Black, taking interest in the proposition, conceived the idea that such an experiment, requiring a long time of continuous, unchanged policy, had best be removed from the ever-changing influences of politics and should be entrusted to a strong and stable educational institution.

This thought suggested the desirability of going a step farther, namely, to provide at the same time for the education of professional foresters, the future managers of the State's forest property, when, with the accomplished demonstration and the existence of competent technical advice, the constitutional bar to rational forestry might be removed.

Cornell University was selected to under-

take the experiment; a bill was drafted and introduced into the Legislature early in February, was passed and received the Governor's signature in April, and on the 16th of that month, by action of the Board of Trustees, the University accepted the responsibility and established the college by election of the writer as its director.

Although a State institution, and as such dependent upon appropriations provided by the Legislature, the College, while having its own separate faculty organization, is organically connected with the University and has the benefit of the entire apparatus of the same with the 180 or more professors and instructors, at least 30 of whom will be called upon to furnish instruction to students of the College in fundamental and supplementary sciences.

In thus connecting the forestry school with a fully equipped university the most advanced German ideas in forestry education are realized. While in that country, in which forestry is most advanced, only three of the nine higher schools of forestry are located at universities, it has become more and more apparent to the educators, even to the directors of the separate institutions, that the advantages derived from the broader education and fuller equipments of universities far outweigh the advantages of the separate academy, which were mainly seen in their location near the woods and demonstration areas. It is now recognized that with modern methods of communication the woods can be more readily reached from a railroad center; that at any rate only a limited amount of practical instruction is possible at the school, wherever situated, the practice coming preferably after a thorough theoretical instruction; and, finally, that the local isolation of the academy is a detriment both to professors and students by its mental isolation. At the university the courses in fundamental and supplementary sciences, which include

mathematics, physics, chemistry, geology, botany, zoology, political economy, engineering, law, can naturally be more thoroughly provided.

For the present there are three teachers of forestry provided at the new college, namely, the director and two instructors, with the possibility of using the manager of the demonstration or college forest to assist, although the distance of the latter would make such participation of the manager in educational lines possible only during summer courses and on excursions to the school forest.

This teaching force is equal to the lowest requirements and can be satisfactory only in the beginning, while the college is in its infancy. The best German institutions have four and five full professors, and only the less favored are satisfied with two full professors of forestry, who are then not burdened with administrative functions.

The University of Munich has six professors of forestry, of whom two, however, are teachers of dendrology and soil physics, which are not exactly forestry branches, but form fundamentals to be taught in the departments of botany and geology.

A satisfactory organization which would do justice both to the teaching and the investigation work, such as is here even more needed than abroad, would require three full professors with at least two instructors or assistants corresponding to the three groups into which forestry subjects can be divided according to their bases, namely: those which are mainly based upon natural sciences and are concerned with forest crop production—silviculture, forest protection, timber physics; those which are mainly based upon mathematics and engineering knowledge and are concerned with the practical management of a forest property—forest exploitation, forest mensuration and forest regulation; those which are mainly of a philosophical character, requir-

ing a full appreciation of all the bearings of the subject, under which head forest administration, forest valuation and statics, history, statistics and forestry politics may be grouped.

The assistants would find ample work in aiding the professors in the lecture room, on excursions or practical demonstrations and in carrying on special investigations.

In spite of the present deficiency in the faculty, which is, moreover, on account of the deficient appropriations—\$10,000 for the first year—limited to the director and only one assistant professor, who acts also as forest manager, the courses of studies announced have been nevertheless made full, comprising twelve courses, the expectation being that no students for the senior year will be ready before the deficiency in the faculty may be supplied under increased appropriations.

The course of studies leading to the degree of Bachelor in the Science of Forestry has been made to cover four years, corresponding in this particular also not to the general practice, but to the most advanced ideas of German educators in forestry. In this course the first two years are entirely given up to studies of the fundamental sciences, while forestry subjects and supplemental studies are left for the last two years. This arrangement has the advantage that forestry students may lay their foundations at any other institution, and, also, should any entering upon the course for some reason desire to abandon their purpose they will not have wasted any time on the specialty, but find themselves prepared for any other study involving natural sciences as a basis.

The required fundamental and supplemental courses comprise altogether about 1,270 hours, to which 450 hours' supplemental work are added as elective but desirable, while the forestry branches represent about 600 hours, of which 130 are

optional, making an average of about 17 hours per week of required and elective work.

In the fundamental branches, botany, chemistry and geology, with allied sciences, require the foremost attention, while a considerable amount of time is given to mathematics, entomology, political economy and engineering, especially map-making and road-building. It is also proposed to add a course on pisciculture and venery, since the future forest managers, at least on the State property, will undoubtedly have charge of the taking care of fish and game, which generally or often form parts of a forest property.

While these full courses are designed to equip, as completely as may be, managers of large properties on which wood-cropping is to be carried on as a business, the College will also endeavor to satisfy other classes of students who desire only a more or less cursory knowledge of the subject or some of its branches, such as students of political economy, or owners of timber lands, who wish to practice at least silviculture. Finally, the requirement of the law, which prescribes that the College shall impart the results of the management of the demonstration forest, will be construed to mean that the function of the College is to pull up the stumps of ignorance regarding forestry wherever they present themselves; the University Extension spirit will prevail.

Later, it may also establish summer schools designed to educate foremen and under-foresters in the principles of forestry, an educational move which is as much needed as that for the training of forest managers, for which the College is originally designed to provide.

The one drawback under which the College will labor at first and for some time to come is the absence of object lessons in the field, the demonstration of principles applied in practice. To be sure, a demonstra-



tion area of 30,000 acres has been set aside in the Adirondacks, which will in time supply the deficiency—sooner in some directions, later in others, since results in forest management are as slow to accomplish as the slowness of the crop would lead us to expect.

Since, however, the conditions in the Adirondacks are special, not only on account of the topography and climate, but because of the few species of timber trees involved, this one demonstration area cannot suffice, and in order to get variety of conditions other areas will have to be secured.

This does not necessarily imply purchase of such areas by the State; it will be possible by and by to secure the cooperation of private timber-land owners, who may permit the College to prepare working plans for their lands and may be willing to apply forestry principles in their management, first, in that generous spirit by which all our educational movements are supported, and finally because of the financial benefits they may derive from it.

There are now some such attempts at forest management to be found in various parts of the country which may be visited by the students during excursions in vacation time. Finally, a visit to the European forests under management will be found profitable to students at the end of their studies, and with full theoretical knowledge to guide them even a brief visit will be full of interest and educational value.

The demonstration in the Adirondacks, as far as forest regulation and administration is concerned, may be made to form a pattern for almost any other region; as far as *silvicultural* methods are concerned, its teachings will be applicable not only to the entire Adirondacks, but to a large part of the New England forest areas, in which spruce is or has been the principal timber tree.

It may be interesting and useful for a fuller conception of what is involved in forest management to point out briefly what the policy and *modus operandi* to be pursued in the college forest is to be.

The leading thought in the management of a forest property is *permanency*, for it contemplates the devotion of the soil to the continued production of a crop, which it takes a century, more or less, to mature. Hence all plans and all operations must take into consideration a long future and all preparations must be made, as for a stable, permanent conduct of a business, unlike those of the lumberman, who exploits the forest only as a speculation, who is not in the business of forest or wood production, but is a mere harvester, the difference being similar to that between the breeder of cattle and the butcher.

The first business of the forester, then, is to become thoroughly acquainted with all the details of his property. He must study its topography, with special reference to the possibilities of making every part accessible to market at any time for its various products. He must know its soil conditions to judge of the variable productiveness of each acre; its forest conditions, to give an insight as to the kind of operations required in each part, in order that the forest may be brought into most productive condition; its contents of merchantable material and rate of growth to determine the amount of annual harvest, which a conservative management will permit. This forest survey is made in connection with or preferably on the basis of a topographical survey.

Next comes the task of preparing the property for an orderly and systematic business conduct by dividing it into subdivisions or compartments of smaller or larger area, business units, which may be designated by letters or numbers, just as the blocks and houses in a city or the rooms in a hotel are numbered for con-

venient administration. The subdivisions, based on topography, difference of soil, forest conditions and other business and silvicultural considerations, may or may not at first be permanently designated in the forest, but finally they will be so fixed, not only on the map, but on the ground, and, possibly, by opening lanes between the compartments, which are preferably so located that they can be used as roads. In the end, the ideal organized, managed forest will look not unlike a city with streets, making every part of the property readily accessible. In practice this ideal may never be quite attained and temporary means of transportation, like rope-ways, movable railways, log-slides, etc., may be substituted for the roadways, where more practicable, just as elevators supplant the stairs in the apartment and business house.

While this more or less geometrical and arithmetical basis for management is laid and partly, as a result of these data, collected, the general policy of management is determined upon and finally its progress is regulated by working plans, for a more distant future in general and for the nearest future in detail.

The manner in which this forest regulation proceeds may be as follows :

We have to deal in the Adirondacks with a mixed forest of hardwoods, birch, maple and beech, in which spruce forms a prominent admixture, sometimes at high elevations, the latter occupying the ground almost exclusively ; and of other useful species, not merely weeds, white pine, fir, cedar and aspen occur more or less scattered or in groups.

We come to the conclusion that, all points considered, the spruce in these mountains is the most valuable timber, with the other conifers desirable concomitants, the hardwoods, although now in preponderance, being less readily marketable ; and we also consider that this relative value of the

species will continue for the future, since the use of the spruce for paper pulp, with few desirable substitutes known, promises continued market for even the inferior material.

Hence we formulate our silvicultural policy : The management is to be based for spruce. It is to be the endeavor to change from the present condition of hardwoods with an admixture of spruce to spruce with an admixture of hardwoods, the admixture being considered desirable for various reasons, among which specially counts the danger to which the shallow-rooted spruce is exposed from winds, which is alleviated by association with other species.

To carry out this policy it is evident the hardwoods must be numerically reduced, the conditions for the reproduction of spruce made favorable and the young growth of spruce favored by subduing its competitors — operations which require the highest skill of the silviculturist.

At the same time the administrator's care is to secure a market for the hardwoods and the means of transporting the same cheaply enough to at least pay for their removal. In this respect it is not enough to sit still and wait for the consumer to come, but active canvass and perhaps reform in the methods of the market and the utilization of the product may be necessary. There are as wasteful methods still to be found in the market and the manufacture of wood materials as in the exploitation in the forest, and reform in the latter direction depends largely on reform in the former. A study of the market, therefore, of its requirements and possibilities of change is most essential for the successful forest manager.

A further formulation of silvicultural policy is as to the kind or system of management under which the reproduction is to be secured. There are two general classes possible. Cutting away the old growth and

planting a new crop just as wanted appears the simplest system. Yet, aside from other flaws which adhere to this method, it would under our conditions of labor be too expensive to employ, except on such areas as are now denuded or devoid of desirable species, or else for demonstration of methods and results. In such cases other species adapted to the locality and promising both silvicultural and financial success, among which especially is the white pine, would be favored.

The other class of management for reproduction, which depends upon natural seeding from the trees on or near the area to be reproduced, offers several methods, among which the method of selection in which mature trees here and there selected through the forest, or certain parts of it, are taken resembles most the lumbermen's present method, except that he is influenced only by the marketableness of his trees, while the forester keeps foremost the benefit to the young growth that is left. This method is especially adapted to those portions which are situated on the high elevations, crags and heads and wherever it is dangerous to expose the soil. Modifications of this system, for instance one in which groups of trees are removed and the reproduction, therefore, is secured by clumps rather than by single individuals, may be acceptable in other parts of the property, and finally for the sake of demonstration all other systems of management, such as the strip system, the nurse-tree system, etc., may be practiced on smaller or larger areas.

One of the most difficult and important questions to be determined, especially with regard to financial results, is the rotation, *i. e.*, the age to which the crop is to be allowed to grow before utilizing it. Unlike other crops, the harvest time of which is determined by natural limits, their ripeness, the harvest of the wood crop is not so

circumscribed. There is a choice as to when to harvest it, into the making of which a number of considerations enter. First, of course, useful size is the main consideration; the production of hoop poles, hop poles, vineyard stakes may be satisfied by a ten to twenty years' growth; railroad ties may be secured in thirty to forty years, and so on. Where reproduction from seed is expected, the age at which frequent and prolific seed production takes place, maturity in the sense accepted for animals will set the lowest limit; finally, however, since the business of forest production is mainly carried on for financial results, the financial rotation must be determined, *i. e.*, that time at which it pays best to harvest the crop. Quantity of production as well as change in quality, both of which are variable with age of the crop and market conditions, influence its choice. A series of measurements of the rate of growth of the wood crop and calculations based on them and on cost of production and administration and consideration of market requirements, present and conjectured future ones, lead to the adoption of this regulator of the time element in reproduction.

These calculations may lead us to adopt a rotation of eighty years for parts of our school forest of spruce with hardwoods and 100 years or more for other parts; that means we would distribute our fellings in such a manner that by annually or periodically equal or nearly equal amounts we remove all the wood that has been produced during the period of 80 or 100 years respectively, taking care that as much wood is left to form what is called the normal stock of wood, the working capital of wood necessary to secure by annual accretions the most desirable and profitable production of which the property is capable.

These calculations also lead finally to the conclusion as to the amount of wood that may be annually or periodically cut without



reducing the normal stock or wood capital and representing, as it were, the interest. We may, for instance, come to the conclusion that on our 30,000-acre tract an annual felling budget of two to three million feet, B. M., of logs and eight to ten thousand cords of wood may be indicated, for which we must secure a market. It may also be found that the working capital of wood, an accumulation of capital and interest for centuries as found in the virgin forest, is unnecessarily large, beyond the normal, and hence should, for good business reasons, be as quickly reduced as it can be done profitably, or else if we have to deal with cutover lands we may have to reduce our annual cut, saving gradually enough to first establish the desirable working capital.

Finally, when all these bases for operation are ascertained we may formulate the working plans and decide not only on the quantities to be cut, the operations of improvement required, the manner of conducting the whole management, but also determine in what portions of the property the principal activity is to be exercised during the first ten or twenty years, leaving it to the future manager to modify the plans as experience and changes of condition indicate.

That a well-planned bookkeeping is necessary if we would want to know how our business progresses is self-understood. Not only is it necessary to keep those accounts of financial transactions which any business requires, but each compartment in the forest must be kept account of, with a separate ledger account to show what material it has furnished, what stock remains in it, what operations it has required and whatever position in the general scheme it takes.

A demonstration and experimental area, as the proposed school forest is to be, will, to be sure, entail many operations which in a mere business forest might be dispensed with or delayed to more opportune time.

Hence its financial results on the whole may not satisfy the financier. No such experiment, it may be asserted, can be made to demonstrate the profitableness of a business; it can only serve to show methods and their results and to furnish the basis and elements for profit calculations. Nevertheless it is expected that the experiment will pay for itself, while furnishing the desirable object lessons both to the students and timberland owners, the citizens of the State of New York, owners of the great State Park, included.

When this experiment is established, and has demonstrated that rational forest management is possible in this country as well as in the older countries, the constitutional bar will undoubtedly be removed and the entire State holdings placed under proper technical administration, with the students from the State College of Forestry its managers.

B. E. FERNOW.

CORNELL UNIVERSITY.

*GEOLOGY AND GEOGRAPHY AT THE AMERICAN ASSOCIATION MEETING.*

II.

14. *Another Episode in the History of Niagara River.* By J. W. SPENCER, Washington, D. C. This paper is a sequel to one read before the American Association four years ago, on the duration of Niagara Falls. It announces the discovery that while the falls were receding from Foster's flats to the locality of the railway bridges the fall of the river reached its maximum of 420 feet by the retreat of the Ontario waters to the north. The return to the present amount of 326 feet was interrupted by the rising of the level of the lake in the gorge to a height of 75 feet above its present level, thus reducing the actual fall of the river to 250 feet. The evidence of this is preserved in the remains of a terrace deposit opposite the foot of Foster's flats and

a corresponding terrace just outside the mouth of the gorge; and these terraces, with other parts of the shore line in the Ontario basin which marks the rise of the waters so as to flood the Niagara gorge, are here named the Niagara strand. The rising of the waters was occasioned by the lifting of the barrier at the outlet of Lake Ontario to an elevation 100 feet higher than now. By the subsequent erosion of this barrier, which was partly composed of drift, the actual fall of the Niagara waters has been increased to its present figure. The reduction of the descent of the river is found to be sufficient to account for the shallowness of the channel at the Whirlpool rapids. The narrowing of this section is explained by the fact that the youthful Niagara took possession of a small preglacial valley there, giving greater depth to the river. It is further probable that the volume of the river was less at that time, since it is supposed that a portion of the outflow of the Great Lakes then passed to the Mississippi.

15. *The Age of Niagara Falls as Indicated by the Erosion at the Mouth of the Gorge.* By PROFESSOR G. FREDERICK WRIGHT, Oberlin, Ohio. The late Dr. James Hall early noted the significant fact that "the outlet of the chasm below Niagara Falls is scarcely wider than elsewhere along its course." Clearly this is important evidence of the late date of its origin, and it has been used by the author and others in support of the short estimates which have been made concerning the length of time separating us from the Glacial period. A close examination made by the author this summer greatly strengthens the force of the argument, since he found that the disintegrating forces tending to enlarge the outlet and give it a V-shape are more rapid than has been supposed. The depth of the gorge at the outlet, from the top of the Niagara limestone to the river, is 340 feet. The thickness of that formation of limestone at

the surface is here, however, only about 40 feet; while the soft Niagara shales underlying it are from 60 to 75 feet thick. Below there is a stratum of Clinton limestone 30 feet in thickness, and below that a shaly deposit of 70 feet. The Niagara shales at this point have never been covered by talus, so that they have always been accessible to disintegration by atmospheric agencies.

Somewhat over forty years ago a railroad was built along the face of the eastern side of the gorge, affording an opportunity to observe the rate of disintegration. All along where a perpendicular exposure was made, the shale has crumbled away to an extent of several feet, and in some places to that of 20 feet. A conservative estimate of the rate of disintegration for the 70 feet of Niagara shales supporting the Niagara limestone would be one inch a year, with a probable rate of two inches a year. But at the lowest estimate no more than 12,000 years would be required for the enlargement of the upper part of the mouth of the gorge 1,000 feet on each side, which is very largely in excess of the actual amount of enlargement. Some of the recent estimates, therefore, which would make the gorge from 30,000 to 40,000 years old, are evidently extravagant, and must incorporate some error in their premises. The age of the gorge cannot be much more than 10,000 years, and is probably considerably less.

16. *A Recently Discovered Cave of Celestite Crystals at Put-in-Bay, Ohio.* By PROFESSOR G. FREDERICK WRIGHT. The principal locality in America from which museums have been supplied with specimens of celestite (sulphate of strontium) is Strontian Island, two or three miles from Put-in-Bay Island, in the western end of lake Erie. Just as this supply was becoming exhausted, a remarkable fissure was discovered last winter on Put-in-Bay Island, which is completely surrounded with very large crystals

of this beautiful mineral. The fissure was penetrated in digging a well seventeen feet below the surface, and is large enough to permit the entrance of ten or twelve people at a time. It is not an ordinary cavern, but apparently is the interior of an immense 'geode' lined with celestite crystals. The geological formation in which it occurs is the Waterlime of the Lower Helderberg. Large deposits of gypsum occur in the vicinity.

17. *Geography and Resources of the Siberian Island of Sakhalin.* By PROFESSOR BENJAMIN HOWARD, London, England. Sakhalin has a length of about 670 miles and a breadth of 20 to 150 miles. The features which the author observed during his visits to this island in 1890 and 1896, as here described, are (1) the absence of natural harbors and reliable anchorages around its entire 1,500 miles of coast, and the reasons for it; (2) the contrast which this island, having no volcanoes, exhibits as compared with the volcanic chain of the whole Japanese group and its continuation in the volcanoes of Kamtchatka; (3) the contradiction which Sakhalin, possessing an almost subarctic climate, affords to the popular belief that latitude is the dominant factor in the determination of climates; (4) its mineral resources, especially coal and iron; (5) the immensity and density of the fish shoals in the neighboring waters; (6) the absence of navigable rivers; (7) the persistence of unadulterated life and manners in the aboriginal Ainos there as when described nearly three thousand years ago by the oldest Japanese historian; (8) the vast numbers of medusæ (jelly-fish) along the southern coast, and the marvelous phosphorescence of the sea as witnessed by the author; (9) the strategic value of the island to Russia; (10) the completeness of its adaptation to its present use as a penal stronghold; (11) the present development of its agricultural and mineral resources,

and its prospective self-maintenance chiefly from its future fishing industries; and (12) the expediency of maintaining the spelling of the name Sakhalin, as here used.

18. *Evidence of Recent Great Elevation of New England.* By J. W. SPENCER, Washington, D. C. This paper was a description of the valley terraces in mountainous parts of New England, illustrated by sections showing that the declivities of the valleys are not by even slopes, but by a succession of steps, the plains of which become terraces farther down the valley. These steps are regarded as gradation plains in the changes of the baselevel of erosion, and many of the corresponding terraces are hundreds of feet above the floors of the valleys. From these features it is inferred that the recent rise of the mountainous region can be approximately measured by the sum of the heights of the steps. Yet it is not inferred that the elevation need have been from below the sea level; and consequently the gravels are not claimed to have been necessarily of marine origin.

19. *The Oldest Palæozoic Fauna.* By G. F. MATTHEW, St. John, N. B. This fauna is contained in a series of beds unconformably underlying the Cambrian system in eastern Canada and Newfoundland. The base of the Cambrian in the former country is marked by a barren sandstone, and in the latter by conglomerates. Erosion of the lower terrane continued up to and included the time of the Paradoxides fauna. The relation of these two terranes is comparable to that of the Upper and Lower Silurian in New York, or the Carboniferous and Subcarboniferous in eastern Canada. The fauna known consists of about twenty species. It contains no trilobites either in eastern Canada or Newfoundland. Various forms of the family Hyolithidæ are the dominant types. Other gastropods allied to *Capulus* and *Platyceras* occur; also brachiopods; remains of echinoderms (cys-



tids?); and corals allied to *Archæocyathus* and *Dietyocyathus*. The thin limestones which occur in the upper half of the terrane are supposed to have originated chiefly from foraminifera (*Globigerina*, etc.).

20. *The Oldest Known Rock*. By PROFESSOR N. H. WINCHELL, Minneapolis, Minn. With a brief description of the other members of the Archean series as made out by the Geological Survey of Minnesota, this paper more particularly described the so-called greenstones of this State, which the author considers the bottom of the Archean scale and the representative of the original crust of the earth formed from the molten mass by the earliest consolidation. The greenstones are divisible into two parts, one igneous and the other clastic, the latter succeeding the former with a confused and apparently sometimes non-conformable superposition, somewhat as surface eruptive rocks might be superposed, in the presence of oceanic action, upon a massive of the same nature at the same place. The clastic portions of the greenstones vary to more silicious rocks, constituting great thicknesses of graywackes, phyllites and conglomerates; and as such they have been converted by widespread metamorphism into mica schists and gneisses, the alteration coming on by degrees, increasing in intensity toward centers of granitic intrusion and toward the great areas of granite and igneous gneiss.

Such granite and such metamorphic rocks, as a whole, have been considered the basement rock, the oldest known rocks of the country. But, following up the long known fact that the Laurentian granite and igneous gneisses cut the schists and sedimentary gneisses and hence are younger, they are thus shown to be younger also than the bottom greenstones. They occasionally penetrate these greenstones and change them to amphibolyte and pyroxene gneiss. These metamorphic schists and gneisses

seem to be a representative of the sedimentary portion of the Lower Laurentian of Canada, while the igneous granite and gneisses are as plainly a general parallel of the igneous portion of that series. It follows, therefore, that the Canadian Laurentian is, as a whole, of later date than the greenstones, if the succession is the same as in the Northwest, and that the greenstones should be considered the bottom rock of the geological scale.

21. *The Origin of the Archean Igneous Rocks*. By N. H. WINCHELL. The greenstones, which were discussed in the preceding paper, are supposed to represent the primeval crust of the earth. The author denies the possibility of the derivation of the alkaline magma from these ferro-magnesian rocks by any of the methods of lixiviation or of differentiation which are currently proposed by geologists who have lately discussed the origin of the igneous rocks. Accepting this ferro-magnesian crust as the rock of the first magma of the earth, the author shows that it could not give rise to minerals consisting largely of a potash base, such as orthoclase and microcline, which constitute the greatest distinguishing element in the alkaline magma. Neither could it give rise to the preponderating percentage of silica which accompanies the potash minerals. These characters, therefore, must have some other source. The potash is believed to have existed in the ocean itself which immediately followed the consolidation of the first crust. Such an alkaline ocean, especially if heated, would hold in solution much silica. Hence followed the precipitation of alkaline silicates, and of excess of silica; hence, also, the alkaline character of the schists and gneisses when its sediments were formed into rock and metamorphosed; and hence, when fused, the alkaline magma. As to the cause of this potassic ocean by which the great stock of the world's potash was

stored in the Archean rocks, the author does not attempt any explanation, further than to suggest that possibly, owing to the chemical characteristics of potassium, it remained in the earth's atmosphere until the consolidation and also the cooling of the first crust sufficiently to allow the ocean to rest upon it, and that it was then rapidly extracted by the moist, heavy atmosphere that prevailed, being carried into the sea.

22. *Joints in Rocks.* By PROFESSOR C. R. VAN HISE, Madison, Wis. (Read by title.)

23. *Notes on Some European Museums.* By DR. E. O. HOVEY, American Museum of Natural History, New York City. Relating to museum administration and methods of display, as observed in Europe; published in the *American Naturalist*.

24. *History of the Blue Hills Complex.* By PROFESSOR W. O. CROSBY, Boston, Mass. Relating to the tract of the Blue Hills, on the southern border of the Boston basin. (Read by title.)

25. *Paleontology of the Cambrian Terranes of the Boston Basin.* By AMADEUS W. GRABAU, Boston, Mass. The Lower Cambrian rocks are found to contain fossils at Nahant, Mill Cove, Rowley, Topsfield and Jeffreys Ledge. The last three localities were discovered by Mr. J. H. Sears, who was also the first discoverer of fossils at Nahant (1887). From collections made by him at Nahant seven species have been identified, including four of Hyolithes. The fossils detected in the rocks of the other localities consist of indeterminate sections of Hyolithes and a cross section of a trilobite from Mill Cove. From pebbles and boulders found at Nahant and Cohasset by Mr. T. A. Watson, a large number of Lower Cambrian fossils have been obtained, representing fifteen species. The Middle Cambrian of Hayward's Creek, South Braintree, contains the large *Paradoxides harlani*, *Agraulus quadrangularis* and several other forms. The Upper Cambrian is represented in this

district only by erratics containing *Lingula* and *Scolithus*.

26. *Diamonds in Meteorites.* By MRS. E. M. SOUVIELLE, Jacksonville, Fla.

27. *The Periodic Variations of Glaciers.* By PROFESSOR HARRY F. REID, Baltimore, Md. (Read by title.) The *Journal of Geology* for July-August (Vol. VI., pp. 473-476) contains an article by Professor Reid on this subject, giving records for Europe, Asia and Greenland in 1896 and for the United States in 1897. A general retreat of the glaciers is noted, excepting slight tendency to advance in Greenland.

28. *Notes on the Occurrence of Tourmalines in California.* By C. R. ORCUTT, San Diego, Cal. Near San Diego an enormous bed or vein of lepidolite (lithia mica), 60 feet or more in width where best exposed, contains rubellite (pink tourmaline) in large amounts. As a source of lithia and potash this deposit must soon take first rank commercially. It is now being worked as an open quarry, and 1,500,000 tons are estimated to be available. Much of the rubellite has been distributed to museums. Tourmalines of gem quality were first found during the present year, being all of the red variety. Black tourmalines are frequent, but green tourmalines occur only sparingly, at this locality.

29. *The Agassiz Geological Explorations in the West Indies.* By ROBERT T. HILL, Washington, D. C. This paper, which, with several preceding, was presented in Cambridge on Friday forenoon in the Museum of Comparative Zoology (largely founded through the labors and munificence of Louis Agassiz and his son, Professor Alexander Agassiz), described briefly the expeditions made during recent years by Alexander Agassiz, with his assistants, for observations in zoology and geology, on sea and land, in the West Indies and on the Isthmus of Panama. Within Late Tertiary and Quaternary time many parts of this region have undergone

great epirogenic movements, perhaps more interesting than those of any other part of the world in such late geologic periods.

Dr. J. F. Whiteaves, Paleontologist of the Canadian Geological Survey, Ottawa, Canada, was elected to be the Vice-President for Section E, and Professor Arthur Hollick, of Columbia University, New York City, to be its Secretary, in the Association meeting at Columbus, Ohio, next year. Geology is also represented in the election of Professor Edward Orton, of Columbus, to be the President of that meeting.

WARREN UPHAM,  
*Secretary of Section E, 1898.*

#### NOTES ON INORGANIC CHEMISTRY.

THE presidential address of Sir William Crookes before the British Association at Bristol this year was concerned with two themes. The first of these was the world's wheat supply and how it can be increased. Not only is Great Britain unable to raise her own wheat supply, but the wheat-producing area of the world is being so rapidly taken up that by 1931 the world will be unable to raise enough for consumption, and the immediate prospect will be a wheat famine. This can be obviated only by increasing the wheat crop per acre, that is by using fertilizers to a much greater extent than is at present the case. The chief fertilizer needed is combined nitrogen. The Chili saltpeter now extensively used is brought from northern Chili, but if used on all wheat land, the supply from the Chili mines would be exhausted in a very few years. Cultures of bacteria which assimilate atmospheric nitrogen have been tried as a fertilizer, but thus far with little success. The great desideratum is a process for the manufacture of sodium nitrate directly from the nitrogen of the air. With an indefinite supply of fertilizer the world's wheat yield can be doubled with little increase of acreage. This would tide matters

over till the latter part of the twentieth century, when it may be hoped that the luxuriant vegetable growth of the tropics will be utilized for food supply. At all events, the wheat famine would be postponed till the present generation has disappeared from active work. It may not prove impossible to solve the problem of 'fixing' atmospheric nitrogen even at the present time. In 1892 Professor Crookes exhibited at a Soirée of the Royal Society an experiment on the 'Flame of Burning Nitrogen.' Nitrogen will burn in oxygen if the heat of the ignition point can be maintained. This can be done by the electric current, and it is calculated, that by utilizing the energy of Niagara for electricity, sodium nitrate can be manufactured at a cost of not over \$25 per ton—less than its present price. This figure would probably be reduced were the operations carried on on a large scale. The amount of nitrate needed for fertilizing the whole possible wheat acreage of the world would be twelve millions of tons annually; Niagara could furnish the electrical energy for the manufacture of this without sensibly diminishing its flow.

The second part of Professor Crookes' address was devoted to recent developments in chemistry and electricity. Dewar's liquefaction of hydrogen and the consequent low temperature work; Ramsay's discoveries of krypton, neon and metargon; Nasini's discovery of coronium in the volcanic gases at Pozzuoli; Marconi's application of Hertz's discovery to telegraphy without wires; Zeeman's phenomenon and the possible light it may throw on the ether; the theory of the Röntgen rays and their nature; a possible theory for the Becquerel rays emitted from uranium and its compounds, and the allied rays from thorium, and Curie's newly discovered polonium—these were all considered, and then the announcement made of a new



element discovered by Professor Crookes among the rare earths. To this the name monium is given; it was discovered by spectro-photography, its lines standing almost at the extreme end of the ultra-violet rays, and hence only visible on the photographic plate. Its atomic weight is apparently about 118. The address concluded with a short reference to the work of the Society of Psychical Research of which also Professor Crookes is President.

J. L. H.

#### CURRENT NOTES ON METEOROLOGY.

##### THE MEAN ANNUAL RAINFALL OF THE GLOBE.

IN the *American Journal of Science* for January, 1882, Loomis published the first chart of the mean annual rainfall of the globe, which has, since then, remained the accepted standard of the world. The annual amounts of rainfall were divided into five groups, and the chart was colored in five shades of blue to indicate rainfalls of (I) less than 10 inches, (II) 10 to 25 inches, (III) 25 to 50 inches, (IV) 50 to 75 inches, and (V) over 75 inches. The data at Loomis' disposal were far from complete. A revised edition of the map was published in 1889, the classification of the rainfalls remaining the same, but five different colors being used to indicate these classes, instead of the five shades of blue employed on the original map. During the years that have elapsed since Loomis' map was published, there has been a large increase in the number of rainfall observations from all parts of the world, and the vast body of material now available has been utilized by Supan in the construction of new rainfall maps. Supan's first publication, 'Die Vertheilung des Niederschlages auf der festen Erdoberfläche,' appeared a few months since (*Ergänzungsheft* No. 124, Petermann's *Mittheilungen*), and his second, 'Die jährlichen Niederschlagsmengen auf den Meeren,' has

just appeared in the same journal (VIII, 1898, pp. 179-182). These articles are of great value. They give us revised charts of the mean annual and the seasonal rainfall over the lands, and also the first chart that has ever been published of the mean annual rainfall over the oceans. These are all based on the latest and best data obtainable, and will doubtless remain the standards for many years. The varying amounts of rainfall, grouped into six classes, are indicated by different colors, the heaviest rainfall being shown in blue, and the lightest in yellow.

##### SYMONS' BRITISH RAINFALL.

MR. SYMONS' annual volume on 'British Rainfall' for 1897 contains a noteworthy article on the 'Mean Annual Rainfall in the English Lake District,' which is a continuation of articles on the rainfall of parts of the same region, published in the volumes for 1895 and 1896. The area under discussion in the present paper embraces about 650 square miles. Records from 147 stations have been utilized, and the aggregate number of yearly records dealt with is 1,612. Two maps accompany the article, an excellent orographical map of the Lake district, and a map showing the mean annual rainfall of the district. Mr. Symons now has 3,318 rainfall observers, truly an imposing number in the little territory of the British Isles, and a body of workers which, under able leadership, is gathering a most valuable store of material. And this material, be it said, is being constantly put to use.

##### NOTES.

THE annual report on the 'Rainfall in South Australia and the Northern Territory in 1896,' by Sir Charles Todd, Government Astronomer of South Australia, contains an account of the great 'heat wave' of January, 1896. This 'heat wave' was one of exceptional severity. At Gundabooka Sta-

tion, on the River Darling, the mean temperature for twenty-four days, from January 1 to January 25, was 120° in the shade. The cause of the protracted hot spell was the persistence of monsoonal conditions over the interior during the month, with weak gradients and light winds, there being no depressions of sufficient energy to drive the cool southerly winds inland.

THE seventh annual bibliographical number (for 1897) of the *Annales de Géographie* contains the usual short notes on climatological and meteorological publications issued during that year.

R. DE C. WARD.

HARVARD UNIVERSITY.

#### CURRENT NOTES ON ANTHROPOLOGY.

ON INSPIRATION.

THE curious phenomenon of trance, voluntary or involuntary, plays the leading rôle in the ethnology of religions. In it all faiths have their origins, and by it most are sustained. A phase of it is known to psychologists as 'suggestion,' but this does not exhaust its aspects. Undoubtedly, both a physiology and a philosophy lie behind its superficial manifestations.

Some striking examples of it among the Slavic peoples are given in the 'Archiv für Religionswissenschaft' (Bd. I., Heft, 3) by Dr. Krauss, of Vienna. They are not surpassed by the Yogin of India or the high-priest of Nagualism, and have been studied by scientific observers.

That wholly exceptional, really inexplicable physical powers are obtained in the 'Yogâ' none can deny; and that equally anomalous psychical faculties are developed under its influence is just as certain. We still await a sympathetic, clear, unbiased study of this pregnant topic.

#### RELICS FROM THE ULOA VALLEY.

THE Uloa Valley opens into the Gulf of Honduras about Puerto Cortes. Attention

was first directed to its archæological remains about 1888 by a German planter, Mr. E. Wittkugel, who opened a number of mounds and made a large collection of pottery, etc. In 1896 and 1897 Mr. George Byron Gordon conducted explorations there under the direction of the Peabody Museum, Cambridge. His results have appeared in the *Memoirs of the Museum*, Vol. I., Nos. 4 and 5. It is amply illustrated, and presents a clear and succinct narrative of the work. The art-remains plainly show the influence of Mayan culture; but there is a residuum which, in the opinion of both Professor Putnam and Dr. Seler (whose report may be found in the 'Verhand. der Berliner Anthropol. Gesell.' 1898, p. 133), should be assigned to some other people.

In the same cover with Mr. Gordon's report on the Uloa Valley is his brief statement about cave exploration near Copan. The results were somewhat negative, not indicating extreme antiquity, though signs of a special art-development were not wanting.

D. G. BRINTON.

UNIVERSITY OF PENNSYLVANIA.

#### SCIENTIFIC NOTES AND NEWS.

A PRICE-LIST of the reprints of the papers of the late Professor E. D. Cope has been drawn up, and can be secured from Mrs. E. D. Cope, Haverford College, Haverford, Pa. Owing to Professor Cope's method of work and untimely death many of his important contributions to science exist only in these reprints, and the list should be secured by all those interested in paleontology, zoology and psychology.

WE are sorry to learn that the editor of *Natural Science* feels compelled to discontinue the editing of the journal after December. He is prepared to hand it over to any competent man of science who will relieve him of all responsibility and continue it as an independent journal. Students of the natural sciences are under very great obligations to the editor of *Natural Science*, whose desire to remain anonymous during the continuance of the journal

should be respected, for conducting through thirteen volumes a journal that has always proved interesting, independent and profitable. It is to be hoped that arrangements can be made for the continuation of *Natural Science* on the same general lines as at present.

PROFESSOR BEHRING has replied, in the *Deutsche Medicinische Wochenschrift*, to those who have criticised his action in securing in the United States a patent for his antitoxin. He states that he is no longer a physician and that it is necessary to adopt business methods to secure money to proceed with his investigations. He further states that his manufacturers will supply the antitoxin in America at the same price as hitherto and in a more reliable form. The question as to how far men of science should patent their discoveries is evidently one of great difficulty, but the case of Professor Behring is complicated by the fact that he was not the sole discoverer of the antitoxin treatment of diphtheria.

THE BOARD of Trustees of the University of Pennsylvania, at their monthly meeting on October 5th, appointed a committee to arrange a memorial meeting in honor of the late Provost Pepper. Other institutions with which Dr. Pepper was connected will be invited to take part in the meeting.

WE regret to record the death of M. Gabriel de Mortillet, the eminent anthropologist. He was born at Meylan (Isère) in 1821. After holding positions in the museums of Geneva and elsewhere, he organized the prehistoric section of the Paris Universal Exposition of 1867. A year later he was appointed curator of the Museum of Antiquities at St. Germain. He was at one time a member of the French House of Deputies, being an extreme radical. His anthropological publications are numerous and important.

WE regret also to record the death of Mr. William Wilson, a distinguished railway engineer, in London on September 28th; of Dr. Charles L. Fox, bacteriologist of the Lowell Health Department, and of Dr. David e Toscani, professor of legal medicine in the University of Rome and for twenty years director of the Municipal Office of Hygiene in Rome.

PROVOST HARRISON, of the University of Pennsylvania, has been elected to the presidency of the Wistar Institute of Anatomy, held by the late Dr. William Pepper at the time of his death.

DR. F. M. BRAUER has been appointed curator of the zoological collections at the Royal Museum in Vienna, and M. Albert Gailard, curator of the Lloyd Herbarium of Angers.

AN archaeological map of New York State is in preparation for the Regents of the University, and will be published soon. Hundreds of sites are already described and located, but fuller information is desired, especially along the Hudson River, except in Westchester County. Notes should be sent to Rev. W. M. Beauchamp, Baldwinsville, N. Y., as soon as possible, and should include area and character of site, direction and distance from some village or town, on which side of any large stream or pond, and nature of relics. Full accounts will be prized, but brief notes will often suffice. To insure attention promptness is desired. The Iroquois country is well covered, but the Algonquin much less adequately.

THE Herbarium of the U. S. National Museum has acquired from Dr. W. H. Forwood the collection of plants made by him in western Wyoming in 1881-2.

THE Sixth International Otological Congress will be held in London at the Hall of the Royal Colleges of Physicians and Surgeons, from August 8th to 12th of next year. The last meeting of the Congress was held three years ago at Florence, under the presidency of Professor Grazi.

THE Central Committee for a Pasteur Institute in India has met at the office of the Director-General, Indian Medical Service, Simla, under the presidency of Surgeon-General Harvey. We learn from the *British Medical Journal* that it was decided that any attempt to start an institution for the sole purpose of anti-rabic treatment was out of the question, owing to the insufficiency of the funds at the disposal of the Committee, and that the most practical course would be to await the eventual outcome of the proposed Institute of Public Health to be founded by the generosity of the Indian chiefs.



It was, therefore, resolved that the Government of India be asked whether it could give any information as to when the Chiefs' Institute of Public Health was likely to take practical shape. Until a reply is received nothing definite will be done. Lieutenant-Colonel Roe, Secretary of the Institute, is proceeding on leave, and Major C. J. Bamber has taken up the officiating appointment.

THE Rev. E. C. Hallett, British Chaplain at St. Vincent, writes on September 17th last, that the steam barque *Southern Cross*, of Sir George Newnes's Antarctic expedition, called in at St. Vincent on September 13th for the purpose of coaling, when very cordial visits were exchanged between the ship and the shore. Captain Borchgrevink and his staff, who were in excellent spirits, most hospitably afforded the the officials and residents of St. Vincent every opportunity of inspecting the vessel before she started again on the 14th on her voyage to the to the South Polar regions.

A TELEGRAM to the daily papers from San Francisco states that Messrs. W. A. Woodruff and C. L. Cleghorn, of Washington, D. C., have sailed for Samoa. They are said to be heading a government expedition to collect rare plants, shrubs and other specimens in the interior of the Samoan Islands.

THE New York *Evening Post* reports that M. Viger, French Minister of Agriculture, has delegated M. d'Anyina, an engineer, and MM. Dubray and Minotier, to come to this country to study the American machinery and tools used in the manufacture of flour, and to ascertain their prices and the cost of transportation to France.

HERR G. WITT, of the Urania Observatory, Berlin, has made an important discovery while searching photographically for minor planets. On August 14th last he found, says *Nature*, on the plate he had exposed, in addition to the trail of the minor planet he was hoping to catch, a second trail which indicated the presence of another of these small bodies moving round the sun with a more than usual velocity. Herr Witt was not content, however, to let the matter rest thus, so he undertook a series of eye observations and measurements which are

necessary for the determination of the elements of the body in question. Herr Berberich undertook the task of investigating its motion from these observations, and the result, as far as is known, is surprisingly interesting. Instead of the object being a new or a previously observed member of that system of bodies which travels round the sun between Mars and Jupiter, it proves to be quite an exception, its orbit lying *within* that of Mars; in other words, it travels in a path which is nearer to the earth than that of Mars. It completes its revolution in a period of about 600 days; that is, roughly, 80 days less than Mars takes; both the eccentricity and inclination of the orbit are considerable. This small body thus becomes our nearest neighbor after the moon, and, although small, will shine when closest to us as a star of the sixth magnitude. No doubt the discovery of this new planet will incite afresh observers of these small bodies; and who will say that this new object is the only member of its kind that performs its revolution round the sun in an orbit between the earth and Mars?

DR. FLORENTINO AMEGHINO has made a remarkable discovery, an account of which we take from *Natural Science*. Details of a nocturnal quadruped have been brought to him from time to time by the Indians, and a few years ago the late Ramon Lista actually saw and shot at a mysterious creature in the interior of Santa Cruz. Apparently bullet-proof, it disappeared into the brushwood, and all search for it proved futile. Lista described the creature as a pangolin, without scales and covered with reddish hair. Despite the fact that Lista was known to be a good observer, Dr. Ameghino could not help feeling that he was deceived. Lista, however, has now been proved correct, for Ameghino received recently from South Patagonia some fresh bony ossicles and a partially destroyed skin. The ossicles were comparable to those of *Mylodon*, but smaller, and they were embedded in the skin, like 'paving stones in a street.' The skin itself is two cm. thick, and of such toughness that it could only be cut with a hatchet. The surface of the skin itself shows an epidermis, not scaly at all, but covered with coarse hair, four to five cm. in length, and of a reddish gray shade. This

Ameghino considers was the animal described by Lista, and as that naturalist unfortunately lost his life while exploring Pilcomayo, and was the only civilized man who had seen it in the flesh, he names it *Neomylodon listai*. The importance of the discovery need not be emphasized here.

PROFESSOR KOCH, with his assistants, Professor Kossel and Dr. Pfeiffer, is, says the *British Medical Journal*, at present in Rome studying the malarial question in all its aspects. The Italian government has placed the state laboratories at his disposal, and the Minister of the Interior entrusted Professor Santiliquido, the head of the laboratories, to welcome him on behalf of the government. Permission has also been granted him to study the cases of malaria admitted into the military hospital and into the hospital of Santo Spirito. Professor Koch has found only a small number of cases of malarial fever in these institutions, particularly in the military hospital, although September as a rule is the month in the year when the greatest number of cases of malaria are received in the hospitals from the Roman Campagna. Professor Koch and his assistants work daily in the laboratory of the Sancto Spirito hospital, and they make occasional visits to the most malarial districts around the city. He has stated that he was led to study malaria in Italy because the Italian school had written and investigated much about it, and the views of the leaders differ so much in many important points that he was anxious to come to a definite conclusion on the whole subject, if possible. In discussing Ross's work in India in connection with Manson's mosquito theory, he spoke in the highest terms of Ross's investigation. Professor Koch intends to leave Rome about the end of September, when he and his assistants most probably will go to Greece to continue their malarial studies in that country.

THE report of the Keeper of the Manchester Museum, says *Natural Science*, refers to the installation of electric light, which has been rendered possible by the generosity of Mr. Reuben Spencer, who contributed £500 to the expense. The Museum is at present in the hands of the painters, and it is to be hoped that the committee

will sanction the general whitening of the ceilings asked for by Mr. Hoyle, in order that the electric light may have a good start. Professor Hickson has been doing good work on the plankton of Lake Bessenthwaite, and some of the rarer forms will shortly be placed on exhibition. Miss Nördlinger, the keeper's secretary, has taken entire charge of the library. The committee have undertaken the printing of Mr. Sherborn's index to the 10th and 12th editions of the 'Systema Naturæ' of Linnæus, which should prove of value to zoologists, as these books form the starting-point of zoological nomenclature. A series of lectures will be delivered by Professor Boyd Dawkins on certain Saturdays and Sundays between October and June, and other lectures will be delivered by the staff as usual. Mr. Hoyle closes his report with an appeal for more funds, Manchester spending only £2,785 a year on its Museum, while Liverpool spends £5,700.

THE *Scientific American* gives the following statement of space at the Paris Exposition of 1900 as arranged by the Commissioner-General, Mr. F. W. Peck :

	Sq. ft.
Agriculture and food products.....	20,000
Army and navy.....	3,300
Chemical industries.....	5,160
Education, instruments, practical sciences, and arts.....	11,470
Fine arts.....(not yet known)	
Forestry, hunting and fisheries.....	3,300
Heating apparatus.....	4,500
Horticulture.....(not yet known)	
Machinery and electricity.....	50,000
Manufactures.....	25,000
Mines and mining.....	7,700
Textiles.....	13,000
Transportation and civil engineering.....	20,000
Total.....	163,430

It has been decided, as we learn from the *London Times*, to hold an exhibition in Coolgardie next year, and the government of Western Australia has resolved substantially to support the undertaking by a money and land grant. The proposal has been warmly taken up by the people of Western Australia, by whom a representative executive commission has been elected. The original proposition was

to hold a mining machinery exhibition, and to open the same in October, 1897, but the proposal received so much support in the colony, and was responded to so freely by manufacturers in all parts of the world, that it became necessary to fix upon a later date, and to make the exhibition more comprehensive. The scope of the exhibition was therefore enlarged, and it was determined to call it the Western Australian International Mining and Industrial Exhibition, the objects of which should be to obtain the fullest and best possible display of mining and other machinery, and of all kinds of manufactures suited to the requirements of the mining, timber and agricultural industries of the colony, and to its growing population, in order generally to promote and foster industry, science and art, to encourage invention, and to stimulate commerce in the goldfields and throughout the colony.

THE Commissioners of Fisheries, Game and Forest, of the State of New York, have issued their Second Annual Report. Nearly 200,000,000 fish were placed in public waters upon the application of local authorities. Atlantic salmon fry and yearlings, American brook trout (*Salmo fontinalis*), rainbow trout (*Salmo irideus*), Sunapee trout, Swiss lake trout obtained from the Swiss government, and Labrador whitefish, are among the species introduced, and in addition various streams and lakes have been stocked with different forms of fish food. The report contains articles by Professor J. D. Quackenbos, on the American saibling, a member of the Salmonidæ, which has only recently attracted attention; by Mr. G. W. Rafter, on stream-flow in relation to forests; by Mr. Surface, on the game birds of the State, and other matters of scientific interest.

THE U. S. Fish Commissioner has presented to Cornell University a collection of fresh-water and salt-water fishes, numbering between four and five hundred thousand specimens. The collection, in so far as it consists of living fishes, will be of great value not only to the zoological department, but also to the College of Forestry, in which a course in pisciculture and venery is to be introduced. It is understood that duplicates of this collection are to be presented to other institutions.

#### UNIVERSITY AND EDUCATIONAL NEWS.

THE will of the late Col. Joseph M. Bennett, who during his life-time had made generous gifts to the University of Pennsylvania, leaves to the University property valued at \$400,000. The money is to be used for the higher education of women.

A SUM of money, said in the daily papers to be \$158,000, has been given by friends of Barnard College to pay the entire indebtedness of the College due to its removal to the new site adjacent to Columbia University.

A DONOR whose name is withheld has given Wellesley College an astronomical observatory and a telescope, said to be of large size.

VASSAR COLLEGE receives \$10,000 by the will of the late Adolf Sutro, of San Francisco. The same College has been given \$1,000 by Senator Coleman, of Michigan, the income to be used to purchase books and instruments for the astronomical observatory.

THE estimates of the Navy Department for the ensuing year include \$2,120,000 for the reconstruction of the Naval School at Annapolis.

THE annual report of President Low was presented to the Trustees of Columbia College on September 24th. During the year the University received \$346,409 for permanent endowment and \$43,909 for current uses. President Low urges the building of dormitories, both upon the grounds of the University and adjacent to them. The following account is given of the cost for land, buildings and equipment of the new site:

Cost of land.....	\$2,000,000 00	
Legal expenses .....	3,637 95	
		\$2,003,637 95

Library:		
Construction.....	1,100,542 09	
Equipment.....	97,037 38	
		1,197,579 47

Schermerhorn Hall:		
Construction.....	457,658 17	
Equipment.....	35,786 35	
		493,444 52

Fayerweather Hall:		
Construction.....	274,113 67	
Equipment.....	14,645 43	
		288,759 10



## Havemeyer Hall :

Construction.....	\$516,488 62
Equipment.....	53,474 86

\$569,963 48

## Engineering Building :

Construction.....	284,075 50
Equipment.....	20,325 47

304,400 97

## University Building :

Construction.....	842,887 85
-------------------	------------

Equipment of power-house and connections.....	115,578 52
---	------------

Equipment of gymnasium.....	39,399 24
-----------------------------	-----------

997,865 61

## Vaults :

East.....	30,382 79
West.....	37,316 40

67,699 19

## Old buildings—Repairs and equipment:

West Building.....	10,252 67
College Hall.....	5,113 34

15,366 01

Insurance..... 3,754 40

Outside street work..... 133,367 81

Improvement of grounds and incidents..... 403,373 75

Expenses of removal..... 59,987 56

Interest..... 339,812 08

Total..... \$6,879,011 90

At Columbia University Mr. J. H. McGregor has been appointed assistant in zoology; Mr. S. O. Miller, assistant in mechanical engineering, and Messrs. F. S. Hyde, E. J. Riederer and Victor Linher assistants in analytical chemistry.

MISS ROXANA H. VIVIAN has been given the Alumnae fellowship for women in mathematics at the University of Pennsylvania, and Mr. H. B. Alexander, a Harrison fellowship in philosophy.

THE Hon. John McGregor has given £500 to the fund for the endowment of a chair of forestry in the University of Edinburgh.

DR. FERDINAND FISCHER, of Göttingen, has been promoted to an associate professorship of chemistry. Dr. O. Seeliger, of Berlin, has been appointed professor of zoology in Rostock and Dr. Haussner professor of mathematics at Giessen. Dr. Lorenz and Dr. Keller, of the Polytechnic Institute at Zurich, have been appointed to full professorships of electro-chemistry and zoology, respectively.

## DISCUSSION AND CORRESPONDENCE.

## THE METHOD OF TYPES.

IN discussing the outlook for stability in generic nomenclature\* the method of types has been contrasted with what might be called the method of concepts. The notion of the individual naturalist regarding a certain genus at any particular time is, of course, conceptual, but with increasing knowledge this concept is subject to frequent change resulting commonly in nomenclatorial confusion. With the older naturalists each concept was given a distinct name, while modern practice is less logical in employing a single designation for numerous and varying ideas, to the great detriment of systematic study, since the definite location of genera is rendered theoretically impossible.

The method of concepts originated in the days of mediæval scholasticism, when abstractions commanded great respect and were the subjects of careful study. It was based on the doctrine of the separate creation of species and logically comported with that view of nature. A genus could not be more than an abstraction under a belief which held, in last analysis, that the most similar species were equally distinct with the most diverse. Not only were genera thus assailable, but destructive criticism threatened even the specific idea, as witness certain applications of the oft-quoted assertion of Goethe: 'Nature knows only the individual.' While such ideas obtained, classification could have no logical sanction, its only utility being that of an index giving access to names and descriptions. A system which could do this with the least effort and the greatest dispatch became popular because its users enjoyed a sense of rapidly-expanding knowledge, and much convenience was afforded collectors who preferred their specimens with names. In the manufacture of classifications for this purpose adroit statement often proved more successful than careful study or deep insight. The problem was, indeed, entirely conceptual, the most diverse facts becoming of identical significance if they could be covered by the same formal statement. The resulting conventionalized ideas still figure largely as 'characters,' so that many

\* SCIENCE, August 12, 1898, pp.

existing systems of classifications are simply card houses of abstractions.

Whatever doubt may yet remain as to the causes and machinery of evolution, the doctrine of the separate creation of species is generally relegated to the past. The causal and genetic relationships previously supposed to affect only individual lines are now ascribed also to genera, families and orders. Systematic biology may not remain an index of names; it becomes an integration of all our knowledge of organic nature. There was introduced an element of finality which broadened all lines of study and suggested new interpretations for every fact and phenomenon, and yet the universal advance which this change of base rendered possible has not caused systematists to reconstruct their science in harmony with prevailing views on the origin, differentiation and distribution of life. In other words, there has been no general or consistent attempt at the application to classification and taxonomy of the pertinent corollaries of evolution.

Instead of an infinite array of disconnected forms and facts, only to be combined in artificial concepts, we may proceed in the study of any group of organisms with the assurance that a truly natural or phylogenetic classification is possible, and we have the further satisfaction that such an arrangement when reached will be final and command universal acceptance. The task of the systematist is no longer to study and contrive artful arrangements of concepts, but to gain the clearest possible insight regarding the form, structure and activities of the subjects of his study. All similarities and all differences have value and bearing, not merely those which have been previously used in classification. The deductive method must here, as elsewhere, give place to the inductive. Classification must be built up from below on facts, not suspended from above on abstractions. Affinities must be demonstrated by the production of the connecting links, not inferred from agreement in formal characters. No matter how obscure it may now appear, every species has its history and its relationships, which the naturalist undertakes to discover and to express by his systematic arrangement. He must be ready to accept, record and utilize every new

fact and recognize its bearing on the interpretation of other facts. From one group of organisms an extensive series of concepts may be drawn, and these will be successively advanced and thrown aside, the variable element being our knowledge, while the organisms furnish the constants which our notions should gradually approximate. The excellence of the systematist will depend upon his facility in the construction of new concepts in accordance with constantly changing bases of judgment.

Here is the practical issue regarding the method of types. Shall we continue the practice of naming the concept? Shall we not rather think of the name as applied in the most immediate and permanent manner to the organism? We shall thus have a designation ready for the final entity, but also available for any number of approximating concepts which may follow each other with no unnecessary confusion. Successive systems of classification may then be introduced with a minimum of bibliographic labor on the part of the specialist and a minimum of misapprehension for subsequent students. To maintain the use of the method of concepts because systematic biology had a medieval origin is to stop the dial of progress and decree permanent confusion. And yet this is the purport of the prevalent systems of nomenclature. No existing legislation requires that a genus be anchored to any one point or vicinity. It is not merely a concept, but a negative concept, since it stands at the mercy of all comers, who may dismember at will and remove any of the species without apology. Certain codes will not permit the sequestration of all the original species, but systematists are not always thus considerate and some do not hesitate to take even the last, though they may avoid injury to the concept and use it later for a second set of species. Such jugglery has done its part toward bringing systematic biology into its present disrepute, for while all workers have not followed counsels of confusion, all are at the mercy of the bigoted and the reckless, and while there are many laws determining trifles of spelling and punctuation, there are as yet none dealing adequately with the weightier matters of clearness and permanence in the application of generic names, nor are there

rational provisions for the incorporation of new facts into systems of classification. At present each of these lays its claim to a finality which all past experience declares elusive.

Under the method of types we shall also be emancipated from the notion that all the species of a genus must of necessity possess a certain character or set of characters, and rational methods of description may be introduced. Natural groups are to be recognized and pointed out not only by means of an absolute agreement among their components, but also from the coherence of the parts. A natural genus may frequently be best distinguished from its neighbors on different sides by different characters, and the attention of the careful naturalist is directed toward the discovery and indication of the separating chasms as of the greatest importance in generic demarcation. Under the method of concepts the existence of genera without absolute definitions cannot be consistently admitted, but the method of types renders their stable designation entirely practicable.

Because it is philosophically true that we know things only from their characteristics, it does not follow that the set of formal characters by which we attempt to describe a generic group need be looked upon as the genus, since genera do not exist because their species agree in the few characters touched upon in the description, but because they agree in all except the superficial or quantitative specific differences. Thus, until a group of organisms is thoroughly known, the work expended on elaborate generic definition is largely wasted, each accession of new forms requiring an extensive readjustment. Under the method of types the energy spent on these temporary contrivances could be applied in the interest of a wider knowledge of the group, and that on a permanent basis. A revision of the genera of an order or family would consist in the thorough description and graphic reproduction of typical species rather than in the reshaping of concepts. Differences between naturalists cannot be expected to cease until knowledge becomes complete, but with the attention directed to the type rather than to the concept there would be the important advantage of a fixed and definite

point where all is now uncertain and fleeting. The question of recognition of two related genera would depend on whether the two supposed series or groups of species really stand apart, that is, whether there is a break between them. Nomenclatorially the difficulty is reduced to a minimum. If I recognize one genus the name is A—described in 1820; if two the second is B—described at a later date. If half the effort spent in arranging discarded concepts had been applied to the better description of types our knowledge of genera would be far in advance of the present. The amount of futile labor in systematic biology is appalling, and its practical results are to hamper the naturalist and to close the door of many departments of the science against all who have not a large amount of time for preliminary study of books with little relation to present knowledge or views of classification. Changes of names render the transition from popular to technical literature very difficult, and some considerate systematists have on this account opposed further alterations, even when logically required. Under the method of types it would be possible to select for the illustration of general and popular works species whose systematic standing is of assured permanence.

These are some of the practical benefits which would flow from the application of the method of types, in addition to a nomenclatorial stability out of the question under the method of concepts. Many active systematists are already using various modifications of the suggested method, but its consistent and thorough application under any uniform rule which would eliminate the variable factor of individual judgment, preference or prejudice is apparently barred by the fact that extensive initial changes in nomenclature would be necessary. That many carelessly applied names have escaped into popular use is not, however, a good reason why systematic biology should be kept permanently in its present confusion. The vast majority of names are known, as yet, only to systematists, and the next generation can learn new ones as readily as old, while present workers can well afford an occasional changed designation in consideration of the practical advantages of the method of types.



However, if the specialists in any group can permanently agree among themselves in the designation of the types of genera now recognized, there is no reason why any changes need be made. No new difficulties are, indeed, introduced by these suggestions; but to carry them out would simply bring to definite expression the disagreement and confusion latent among systematists, and make plainer the fact that uniformity and stability stand in inverse ratio to the personal equation; which means that some uniform, and hence arbitrary, method of assigning types for fixing the application of the older generic names will probably be necessary, such as the use of the first designated species.

O. F. COOK.

U. S. NATIONAL MUSEUM,  
September 22, 1898.

#### THE SUPPOSED BIPOLARITY OF POLAR FAUNAS.

DR. JOHN MURRAY, in a recent paper,\* again mentions the supposed general likeness of a large number of organisms captured in the Antarctic seas to those found in the Arctic seas (p. 133). I should like to say a few words on this topic, since I have paid particular attention to this question, and have repeatedly endeavored to show that in most cases this supposed 'bipolarity' does not exist at all, while in others it is no true bipolarity, cases of true bipolarity being extremely rare.

Especially for the Decapod Crustaceans I have found that "not a single bipolar species is known."† This sentence is quoted by Dr. Murray (l. c.), and he tries to show its incorrectness by mentioning the close resemblance of *Lithodes murrayi* Hend. of the Kerguelen region to *Lithodes maja* (L.) from the North-Atlantic, and by adding that—according to a communication by Mr. Henderson—there is no better illustration of bipolarity than that furnished by the *Lithodidæ*.

I cannot admit these objections, since they are not supported by the facts. We possess a very valuable monograph of the *Lithodidæ* pub-

\*On the annual range of temperature in the surface waters of the Ocean and its relation to other Oceanographical phenomena. *The Geographical Journal*, August, 1898, v., 12, No. 2.

†Zool. Jahrb. Syst., v. 9, 1896, p. 585.

lished by Mr. E. L. Bouvier in 1896,\* and Mr. Bouvier has shown plainly—as I have maintained previously—that the chief distribution of the *Lithodidæ* is what I have called *meridional distribution*; that is to say, a distribution in the direction North-South, along the western coasts of the continents. It is a true case of false or mistaken bipolarity, a connection of the Arctic and Antarctic range of this family being present along the western coast of America (and perhaps of Africa). Moreover, according to the key of species and the notes given by Mr. Bouvier (l. c. p. 24), *Lithodes maja* is not at all the most closely allied form to *L. murrayi*; but there are two other species which may claim this distinction, namely: *L. tropicalis* A. M. E. and *L. ferox* A. M. E., both from tropical latitudes off the western coast of Africa, where they have been found in depths ranging from 800 to 1100 meters. This fact again suggests a connection from the Arctic to the Antarctic seas along the western coast of Africa, and we see that true bipolarity in the family *Lithodidæ* as well as in the genus *Lithodes* is wholly out of the question.

I cannot understand at all why Dr. Murray again and again calls attention to the supposed bipolarity of the polar faunas as a *striking* feature in zoogeography. Most of the cases introduced formerly as instances illustrating this bipolarity could not be maintained after a critical examination of the respective zoogeographical facts. Thus, among the Decapods this theory finds no support, as I have shown, and likewise the supposed bipolarity of the Holothurians (Théel) does not exist, since Professor H. Ludwig states that "not a single species of the Antarctic fauna is represented in the Arctic fauna," and that "there is not even a resemblance of both faunas, but a great dissimilarity."

Thus we see that a critical examination lessens the number of the superficially recorded cases of bipolarity, and that my doubts as to the correctness of the bipolarity as a *prime law* or as a *striking feature* of distribution are fully supported, and I am convinced that a careful

\*Ann. Sci. Nat. Zool. (8) v. 1.

†Hamburger Magalhaensische Sammelreise. Holothuriden, 1898, p. 90, f.

investigation in other groups of animals will have the same result. Here I shall add another instance. Dr. Murray (*l. c.*, p. 134) gives a list of bipolar species and genera of fishes (after Günther). Now I took the trouble and tried to verify this list, using the recent publications of Jordan and Evermann\* and of Goode and Bean†, but I was very much astonished to find that this list is of no value at all. After having found out that of eleven bipolar species of this list at least five are really *not* bipolar, and that of twenty-eight bipolar genera at least five are to be dropped, and that seven more are very doubtful, I did not think it worth while to examine the whole list, since it is evident by these facts that it is utterly devoid of scientific value.

In order to avoid any misunderstanding, I wish it to be understood that I do not deny the possibility of 'bipolarity,' and, indeed, I have myself established at least one instance of true bipolarity of a genus (*Crangon*), and I have given an explanation of it. But I protest most emphatically against the view that bipolarity is a striking character of the marine polar faunas, and I also protest against the introduction of doubtful or poorly established facts or of simply incorrect statements or opinions (cf. *Lithodidae*) in support of this 'bipolarity' of species or groups.

ARNOLD E. ORTMANN.

PRINCETON UNIVERSITY, September, 1898.

#### SCIENTIFIC LITERATURE.

*Die Zelle und die Gewebe.* Grundzüge der allgemeine Anatomie und Physiologie. OSCAR HERTWIG. Jena, Gustav Fischer. 1898. *Zweites Buch. Allgemeine Anatomie und Physiologie der Gewebe.* Pp. viii + 314. 89 figs. Preis, 7 Mark.

The first part of the work, of which this forms the second and concluding volume, appeared in 1892. Its appearance, as the author tells us in the preface, was due to three reasons: first, to impart to a wider circle of readers the views set forth in his university lectures; second,

\* The Fishes of North and Middle America, Bull. U. S. Nat. Mus., 47, 1896.

† Oceanic Ichthyology, Mem. Mus. Comp. Zool., v. 22, 1896.

the desire to give to his own investigations, scattered in various periodicals and separate publications, a more comprehensive setting; and third, to crown his 'Lehrbuch der Entwicklungsgeschichte des Menschen und der Wirbelthiere' with more theoretical views, which could not suitably be included there. "But the second part of the book, which includes the subject of the tissues, and which will be about the same size as the first part, will be in a more special sense a completion of the 'Embryology.' For in it, in addition to the description of the tissues, special emphasis will be laid on their origin or histogenesis, and on the physiological causes of tissue-differentiation." The entire work is thus the result of the life-long observations and reflections of one of the most active and successful of modern biologists. It is the product of a true process of growth, and, probably, a final product; for those who have carefully followed the author's writings of the last six years will not find in this volume much not outlined before.

Perhaps the chief significance of the present volume is that it is the first thorough and consistent exposition of Lamarckian principles, as seen in the light of recent embryological work. The leading idea of the entire exposition is the author's theory of development, which he names *the theory of Biogenesis*. The three foundation stones of this theory are stated in the twentieth chapter to be: (1) Lamarckism, *i. e.*, 'to use Nägeli's expression, the theory of the specific and direct action' of the environment; (2) 'the doctrine of the inheritance of acquired characters, or their transmissibility through the germ-cells to the offspring;' (3) 'the doctrine of the continuity of the process of development, and the principle of progression, that is to say, that development' (both ontogenetic and phylogenetic) 'progresses steadily in a definite direction.'

The first seven chapters are preliminary, dealing with 'the Stages of Individuality,' 'Specific (Artgleiche), symbiotic and parasitic cell-union,' 'On the Methods of Interdependence of the cells of Organisms,' 'The Law of Causation in its Application to the Organism,' 'On the Causes Separating Cell-aggregates into Tissues and Organs,' and the 'Theory of

Biogenesis.' A large part of the volume, beginning with the eighth chapter, is taken up with the consideration of the first foundation-stone of the theory of Biogenesis, viz.: specific and direct action of the environment in the individual development. The factors of development are divided into external and internal; the first being defined (p. 75) as 'the different kinds of relationships to the external world with its numerous forces.' The internal factors are of two sorts, viz.: 'the relations of a cell to all other cells of the same aggregate,' and 'the properties and organization of the sexual cells and their derivatives; the internal factors in the stricter sense.' It would seem likely to us to conduce to more clearness if the first subdivision of the internal factors were reckoned as external factors, as, indeed, they are from the standpoint of the organization of the cells. The author discusses this (p. 75), but thinks otherwise.

Under the head of 'External Factors of Organic development' are discussed: gravity; centrifugal force; mechanical effects of traction, pressure and tension; light, temperature, chemical stimuli; more complex stimuli; organic stimuli, such as grafting, transplantation of tissues, reactions between the embryo and mother, and telegony. These subjects are illustrated with many examples drawn from botany and zoology indifferently. Under the head of 'Internal Relations of Organic Development' we have these subjects: the correlations of cells during cleavage; the correlations of organs and tissues in later stages of development and in the adult; chemical correlations; mechanical correlations; the phenomena of regeneration and of heteromorphosis; and, finally, different conditions and modifications of the cells in the adult, such as hypertrophy, atrophy, metaplasia, hyperplasia and necrosis. The mere reading of such a menu is enough to make one's mouth water; but it must be said that most of this part of the volume is pure description; and the facts are set too much in one light, so that the author apparently loses sight, at times, of the importance of the true internal factors contained in the organization of the cell. However, a great quantity of extremely valuable material is here gathered to-

gether for the first time, and it would be ungracious to quarrel with the point of view, considering the service to the teacher.

The second foundation-stone of the theory is the doctrine of the inheritance of acquired characters. The chapters which illustrate and attempt to substantiate this theory are, in many respects, the most interesting of the entire volume. It is here that we find a consideration of 'the most important category of causes in the process of development,' viz., the inner factors in the narrower sense. Inheritance depends on continuity; "but the great problem, so differently answered in the various theories, is not the continuity of life as such, which is a fact of experience, but the methods and means by which the continuity on which the persistence of a species depends is handed on from member to member of a series of generations." It is impossible to give here a detailed account of Hertwig's views on the mechanism of the inheritance of acquired characters; but, having rejected the transmission of mutilations and of disease, he sums up thus: "Changes in the entirety of an organism produced by alteration of any function during the life of the individual induce, if lasting, alterations in the cells composing the organism, especially in that substance which we have called the bearer of the characteristics of the species" (that is, the idio-plasm contained in the nucleus). "Conditions of the entire organism are thus translated into heritable properties of the cell, in a different material system. The hereditary substance of the organism is thus enriched by a new link, a new possibility, which again becomes manifest in the development of the next generation; thus the new individual now reproduces, to a greater or less extent, from the germ or from inner causes, the properties acquired by the parents in their lifetime through reaction to the environment." He seeks to render the difficulty, of understanding how this translation is possible, less alarming by an analogy, following Hering, between this and the capacity of a nerve-cell to store up impressions and reproduce them again through memory. In both cases the process can be reduced to its most general formula by saying: "External causes exercise influences on a complicated organic



system, which can be stored up in it, and become internal causes, manifesting themselves again, in the sequence, in induced phenomena within the system, for the explanation of which they must be used."

The weakest part of the whole book is the chapter entitled 'Die im Organismus der Zelle enthaltenen Factoren des Entwicklungsprocesses.' For the author, all these factors are included in the nucleus; the protoplasm is isotropic; variation in the size and in the rate of cleavage of the cells are due entirely to the distribution of yolk; and its distribution to gravity. "The accumulation of yolk in the egg-cell undoubtedly exercises a far-reaching influence on the course of development, impressing on it a special character. *On this account* many investigators have been induced to regard the egg as something more than a simple cell," etc. (*italics mine*). "But the character of the egg as a simple cell is not in the least altered by the accumulation of material in it." Whitman is supposed to hold this idea, that the degree of organization of the egg is proportional to the amount of yolk in it. Such a grotesque conception of Dr. Whitman's views is inexcusable. To say that "the inequalities which arise in the size and the arrangement of the embryonic cells and in their yolk-contents have nothing to do with the differentiation of organs" is simply untrue, as is proved by the whole subject of cell-lineage, which has put the problem here discussed in an entirely new light, about which a voluminous literature has already arisen, but which is not even mentioned by Hertwig. Think of such a phrase as this: 'the organization of the egg, which depends on the inclusion of deutoplasm!' (p. 265).

The third foundation-stone of the theory of Biogenesis is the principle of progression. A single quotation will suffice to indicate what is meant by this: "Placing ourselves upon the theory of descent, might we not suppose that species develop according to the principle of a steady progression regulated by law, like the multicellular organism by epigenesis from the egg, not as the sport of circumstances, but with the same innate necessity that causes the gastrula to succeed the blastula in ontogenesis?"

The principal points of view of the theory of

Biogenesis are summarized by Hertwig in the concluding pages; they may be condensed thus:

1. "Since all organisms pass through the unicellular conditions in their development, all constant or essential characters by which species is distinguished from species must be contained in their simplest form, or, so to speak, reduced to their simplest expression in this. There are thus as many fundamentally different species of cells as there are different species of plants and animals."

2. The essential distinctions between these cells are not directly discernible. But from logical considerations we are forced to assume "that the cells possess a finer micellar organization exceeding our powers of observation, by virtue of which they are the bearers of the properties of the species," and that this substance, the idioplasm, makes up only a small part of the whole substance of the cell. "According to our theory it is contained in the nucleus."

3. "The cause of continuity in development is that each individual is the product of a cell possessing the same specific properties."

4. As to the causes of the development of the individual from the species-cell, the theory of Biogenesis postulates 'the increase of the species-cell and the correlative process of social union, division of labor and integration.'

5. The process of cleavage is a multiplication of the original cell, all products possessing the same fundamental organization.

6. "The aggregate takes on definite forms during its growth, which in any stage are the expression of: (1) the influence of innumerable external factors; but still more (2) of the endlessly complicated effects which the constantly increasing elementary units exercise on one another."

7. "Within the series of generations of persons, or between the separate ontogenies, the continuity of development is preserved by single cells freeing themselves from the aggregate of the species-cells and becoming the origin of a new process of development."

In conclusion, I cannot avoid criticising the name which the author has chosen for his theory of development. It is not in any sense

a theory of *Biogenesis*. We are told on page 236 that the name was given to express the idea 'that the origin of the complex organism is to be explained from the properties of an elementary being, the cell.' If only it did express this!

FRANK R. LILLIE.

UNIVERSITY OF MICHIGAN.

*Animal Intelligence*. By WESLEY MILLS. New York, The Macmillan Co. 1898. Pp. x + 307.

The first fifty pages of Professor Mills' book are made up of certain theoretical discussions. The rest consists in the main of reprints from the *Transactions, Royal Society of Canada*, already familiar to those who follow the progress of animal psychology. In his theorizing Professor Mills refuses the moderate attitude of Lloyd Morgan, Wundt and other recent psychologists and reverts to a position comparable to that of Romanes. He even calls Lindsay's writings 'admirable.' Here is no place to refute his claims; it will suffice to say that he leaves the problem in the loose and unprofitable form of more or less 'intelligence' instead of resolving it into definite questions about the presence or absence of particular mental processes. Moreover, he wastes his energy on such straw men as the theory that all the actions of animals are due to instinct or that human minds were created especially of quite different stuff. One novelty in his discussion is the insistence that human conceit makes men underestimate animals' capacities. When one thinks of the wide prevalence of animal-worship, of the reverent eulogies of instinct so common in books of the middle of this century, or of his own experience of present opinion about animals, this notion of Professor Mills seems extraordinarily perverse. I should say that we naturally tend to do quite the opposite, to interpret animals' acts by our own minds, and, when any strange act appears, to explain it in the most glorified way possible.

The observations which are recorded in the book concern the habits of squirrels, hibernation, and the early life of dogs, cats, rabbits, guinea-pigs, pigeons and chicks. Such records are of the greatest value, and to Professor Mills is due the credit of doing more of such work, I sup-

pose, than any one else has yet done. The development of the sense-powers, the presence of instinctive reactions of various sorts, the correlation of physical growth with mental development, the formation of habits—data concerning all these are given. One could praise them unreservedly were it not for Professor Mills' habit of occasionally mixing up opinion with observation. On page 139, for instance, he says: "I notice that the precocious bitch acts towards the whip much as an *old dog* or a half-grown one often does. This is difficult to describe. The animal shows that it understands what its relations are, but seems to combine a sort of pleading with humor." The last sentence is a good record of Professor Mills' attitude toward animal psychology, but it is worthless as far as concerns the dog. In harmony with his general theory Professor Mills finds in these young animals signs of reasoning, a moral sense and a sense of humor. Many would interpret these signs very differently.

In closing I wish to say a little about the observational method of studying animal psychology. Without forgetting a single one from among its advantages, the fact remains that, unless you practice continuous observation from birth, you do not get complete control of the animal's experience. Actions which you observe in one hour out of the twenty-four may be due to experience acquired during the remaining twenty-three. The meaning of phenomena is also often dubious. Why then neglect specific experiments, even if you have to use unnatural surroundings? It would seem that if Professor Mills had used a part of his time in making crucial experiments to decide definite questions, he would at least have had a means of checking his other results. Finally, I would beg that anyone who is studying animal psychology to throw light on the human mind, to leave the poor dogs and cats and guinea-pigs and above all the favorite chicken, to feel their feelings in peace and devote himself to the monkeys. Since Hubrecht has shown how early the primate stock split off, it seems far-fetched to call a dog-mind and cat-mind an ancestor in any sense of the human.

EDWARD L. THORNDIKE.

WESTERN RESERVE UNIVERSITY.

# SCIENCE

EDITORIAL COMMITTEE: S. NEWCOMB, Mathematics; R. S. WOODWARD, Mechanics; E. C. PICKERING, Astronomy; T. C. MENDENHALL, Physics; R. H. THURSTON, Engineering; IRA REMSEN, Chemistry; J. LE CONTE, Geology; W. M. DAVIS, Physiography; O. C. MARSH, Paleontology; W. K. BROOKS, C. HART MERRIAM, Zoology; S. H. SCUDDER, Entomology; C. E. BESSEY, N. L. BRITTON, Botany; HENRY F. OSBORN, General Biology; C. S. MINOT, Embryology, Histology; H. P. BOWDITCH, Physiology; J. S. BILLINGS, Hygiene; J. MCKEEN CATTELL, Psychology; DANIEL G. BRINTON, J. W. POWELL, Anthropology.

FRIDAY, OCTOBER 21, 1898.

CHEMISTRY AT THE JUBILEE MEETING OF THE AMERICAN ASSOCIATION.

## CONTENTS:

<i>Chemistry at the Jubilee Meeting of the American Association</i> : PROFESSOR CHARLES BASKERVILLE.....	521
<i>Physics at the Boston Meeting of the American Association for the Advancement of Science (I.)</i> : N. ERNEST DORSEY .....	529
<i>The Advance of Psychology</i> : PROFESSOR J. MCKEEN CATTELL.....	533
<i>The Senff Zoological Expedition to the Nile Valley</i> : H. F. O., N. R. HARRINGTON.....	541
<i>Fishes New to the Fauna of Southern New England recently collected at Woods Holl</i> : DR. HUGH M. SMITH.....	543
<i>Notes on Inorganic Chemistry</i> : J. L. H.....	544
<i>Current Notes on Anthropology</i> :—	
<i>Craniological Opinions; Ancient Graves in Maine; Geography and Anthropology</i> : PROFESSOR D. G. BRINTON .....	545
<i>Scientific Notes and News</i> :—	
<i>A National Physical Laboratory for Great Britain; The Franklin Institute; General</i> .....	546
<i>University and Educational News</i> .....	550
<i>Discussion and Correspondence</i> :—	
<i>Trochosphæra Again</i> : DR. H. S. JENNINGS. <i>The Occurrence in Great Abundance of Insects Ordinarily Merely Common</i> : DR. F. C. KENYON .....	551
<i>Scientific Literature</i> :—	
<i>Some Recent Literature on Child-study</i> : PROFESSOR M. V. O'SHEA. <i>Mehner's Biomechanik</i> : PROFESSOR CHAS. B. DAVENPORT.....	552
<i>Scientific Journals</i> .....	560
<i>Societies and Academies</i> :—	
<i>Geological Conference of Harvard University</i> : J. M. BOUTWELL.....	560
<i>New Books</i> .....	560

THE union meeting of Section C of the American Association for the Advancement of Science and the American Chemical Society in Boston during the last week in August possibly approximated the desires expressed two years ago by the promoters of the joint session. The Jubilee meeting of the American Association dragged many who have not habitually attended the sessions from their seclusion. Those who did come, either for the first time or only after a lapse of years, observed an inspiring sight in the progress in the Association, and we are constrained to believe that Section C contributed its share to the success of the meeting.

Almost three hundred chemists attended the joint sessions. While Section C has been largely composed of members of the American Chemical Society, many more joined that Society, and numerous applications, in turn, were sent to the American Association. We are inclined to the opinion that did other of the affiliated societies but unite with the various sections in joint sessions only mutual good and benefit would result, as has been the case with Section C and the American Chemical Society.

Some 94 papers were presented before Section C and the American Chemical Society; 51 in full, 31 by abstract and 12 by title, representing the various branches



of chemistry. While there were many very interesting papers, perhaps the one that aroused most comment, favorable and conservative, was that of Dr. Chas. F. Brush 'On a New Gas in the Air—Etherion.\*'

This gas, which is found absorbed by many substances, is a constituent of the atmosphere. Phosphorus pentoxide when cold absorbs it, but gives it up on heating. A year and a-half ago Dr. Brush, while looking for occluded hydrogen in glass, found not only that substance, but this new gas. The presence of the new gas made itself known by its enormous heat conductivity at low pressures. In a paper presented before Section B last year Mr. Brush gave the results of his experiments on the heat conductivity of various gases at low pressure. Hydrogen has been regarded the best gaseous conductor of heat. The occluded gas in powdered glass contained some hydrogen, but showed a greater heat conductivity. In repeated trials at purifying the gas by fractional diffusion, each time an increase of conductivity was observed until a gas was obtained with a heat conductivity one hundred times that of hydrogen. The experiments were not reported as continued to a point when the conductivity was the same before and after diffusion, so the impurity of the substance was readily acknowledged.

A table of figures was exhibited, showing the molecular weight, density, specific heat, relative mean molecular velocity and heat conductivity of the gases, whose heat-conducting curves appeared in a chart; and attention was directed to the evident close relationship between heat conductivity and molecular velocity of the gases.

From this relationship some other properties of the new gas were deduced. Taking the heat conductivity of the new gas at a hundred times that of hydrogen—a very

\* This paper was printed in the last number (page 485) of SCIENCE.—ED. SCIENCE.

conservative estimate—its mean molecular velocity at freezing temperature was calculated to be more than a hundred miles per second, and its density only a thousandth part that of hydrogen; while the specific heat was found to be six thousand times greater than that of hydrogen, this substance having the greatest specific heat heretofore known. These figures were adduced simply to show the order of magnitude that may be established by further investigation.

It was shown that a gas having properties anything like those cited could not possibly be confined to the earth's atmosphere, and hence the new gas, being found here, probably extends indefinitely into space and constitutes an interstellar atmosphere, whence its name. The possibility that *etherion* may be found to be identical with the so-called ether was touched upon, and Dr. Brush expressed the hope that it would be found to account for at least some of the phenomena heretofore attributed to the ether. No spectroscopic data were presented.

Dr. Edgar F. Smith's vice-presidential address on 'An Electric Current in Organic Chemistry' was a clear-cut history, first, of the application of electricity to chemistry in general, then to organic bodies in particular. The difficulties in investigating changes in organic substances wrought by the electric current are great, for no single line of reaction seems to be followed invariably and numerous by-products are formed. As this valuable contribution to the history of Electro-chemistry offered by a pioneer in and authority on the subject has been published in SCIENCE, no further reference will be made to it in this *résumé* of the Proceedings of Section C.

All the papers presented at the joint sessions were provisionally divided into the following subdivisions: Inorganic, Organic, Analytical, Technical, Physical, Physio-

logical, Agricultural and the Teaching of Chemistry. Below is given a full list of the titles, but space will not permit abstracts of all the papers presented.

Dr. C. L. Reese exhibited some unusual quartz crystals from Alabama, containing petroleum inclusions.

A paper 'On the Facilities for Standardizing Chemical Apparatus afforded by Foreign Governments and Our Own,' read by Mr. L. A. Fisher for Mr. H. S. Pritchett, called attention to the work begun by the Coast and Geodetic Survey of the United States. In comparison with Germany and France few facilities are now offered by our government, practically none were in the past, so this is an important forward step.

Mr. N. Monroe Hopkins showed drawings of a new Electric Furnace for a 110-Volt Current of High Efficiency. It is easy of construction and inexpensive.

'Catalysis,' Dr. J. H. Kastle. Assumptions regarding catalytic processes from work on sulphonic esters involving the quadrivalence of oxygen were given. Brühl, in his work on hydrogen dioxide, prefers to regard water as containing oxygen unsaturated.

'Volumetric Apparatus,' G. E. Barton.

'Some New Forms of Apparatus,' J. M. Pickel.

'A New Apparatus for Determining the Relative Viscosity of Thick Oils and Softness of Plastic Matter,' A. W. Dow.

'Viscosimeter,' P. H. Conradsen.

Dr. F. W. Clarke called attention to the solubility of certain natural silicates in distilled water, in his paper on 'The Alkaline Reaction of Certain Natural Silicates.' The alkaline reaction is given very quickly by some and more slowly by others. This is an interesting point for geologists.

Dr. C. Loring Jackson, with I. H. Derby, gave the properties of pure, freshly prepared 'Ferrous Iodide.'

One of the most interesting sessions was

that set aside for the discussion of the methods of teaching chemistry. Many outsiders were attracted by this part of the program. Dr. F. P. Venable, who had the leading paper, spoke 'On the Use and Abuse of the Formula in Teaching Chemistry.' Dalton seems to have been the first to use a regular system of symbols in making clear his idea of atoms. Berzelius then took up the practice, which gives us a universal but short-hand language in chemistry. While there is no question of the value of formulas and equations in teaching chemistry, some of the limitations of their use should be recognized. Symbols and equations can only partially represent the mathematical relations of the science, for there is no mode of indicating the physical forces always accompanying chemical reactions. Frequently the best constructed equation represents only one of the many reactions occurring at the same time, and there is no way to indicate conditions, relation of mass and so on. While useful, the dangers may be classified under four heads: methodism, mechanical, mathematical and idolatry.

Dr. Ira Remsen, in his paper on 'Teaching Organic Chemistry,' deprecated 'formula worship' and insisted upon having the thing talked about actually before the student and allowing him not only to see but handle the substance as much as possible. In laboratory work it is more essential to have the student familiarize himself with a few simple compounds first until a basis is established, avoiding the mechanical and acquiring the true spirit and right idea. Many teachers make the mistake of talking over the heads of students. This serves well to exhibit the professor's own mental adroitness, but does not aid the pupil much.

Dr. Hart, when speaking on 'The Teaching of Industrial Chemistry,' insisted that industrial application of what had been learned was the crowning point of all teaching of chemistry. He held the idea that only a

few of the many laboratory students are fit for manufacturing chemists, whose preliminary training should be of the highest order, especially in mathematics. The student should have a wide experience in chemical preparations and be able to purify quickly and study them on a large scale. After such training a man should be sent into a factory for at least two years as a student. Our hope lies in the fundamental training in good technical schools.

Dr. W. L. Dudley asserted, in presenting his remarks upon 'Teaching Analytical Chemistry,' that a good course in experimental work should precede qualitative analysis. If only a little time is available it should be devoted to experimental and not to qualitative analysis, for fear of turning out men who with only a smattering would think themselves real chemists. He did not believe in books for special students, but in true qualitative analysis containing thoroughly accurate methods for the common metals and semi-common ones. He insisted upon the absolute necessity for accuracy and that the course should be comprised of such methods and not of shorter ones that are inaccurate. In quantitative analysis it is better to teach manipulation and principles and not all the methods of analysis known.

In a paper by Dr. H. W. Wiley, read by Dr. E. E. Ewell, on 'The Influence of Temperature upon the Specific Rotary Power of Sucrose,' it was brought out that, contrary to the generally received ideas, there is a marked influence produced by change of temperature, the specific rotary power lowering as the temperature rises.

Three papers were presented by Drs. W. A. Noyes, Hillebrand and N. W. Lord upon coal analysis. The correct determination of water in a coal seems to be obtained only by drying the sample over sulphuric acid in a vacuum desiccator. This is a long method and scarcely applicable in technical work.

This was a partial report of the Committee on Coal Analysis.

'The Determination of Water and Coke in Coal,' W. A. Noyes and N. M. Austin.

'Notes on Determination of Water in Coal,' W. E. Hillebrand.

'The Valuation of Coals,' N. W. Lord.

'Analysis of Mixed Acids,' Chas. E. Munroe.

'A Simple Color Reaction for the Detection of Methyl Alcohol,' S. P. Mulliken and Heyward Scudder.

'Detection of Nitro Group in Organic Compounds,' S. P. Mulliken and E. R. Barker.

'Electrolytic Determination of Tin in Tin Ores,' E. D. Campbell and E. C. Champion. This depends upon fusing the ore with sodium carbonate and sulphur, conversion of the sulpho-stannate into sulphide, then into double ammonium oxalate and electrolyzing.

'The Determination of Undigested Fat and Casein in Infant Feces,' Herman Poole.

'New Method for the Determination of Zinc,' A. C. Langmuir.

'Note on the Determination of Arsenic in Glycerine,' A. C. Langmuir.

Professor H. L. Wells, in his 'History of Double Salts,' stated that the laws governing this class of compounds seem very intricate. The chlorides do not seem to correspond to the bromides, and iodides, and halides of closely related metals often differ.

Dr. J. L. Howe and E. A. O'Neal stated, in their paper on the 'Use of the Electric Current in Forming Alums,' that they had prepared alums containing the metals aluminum, iron, cobalt, rubidium and cesium, by means of an electric current, but failed to get them of manganese and ruthenium. These compounds of rubidium and cesium are next. Dr. Howe, with S. G. Hamner, gave a method for accurately determining 'The Color of Sulphur in the



Gaseous State.' This is variously given in the different text-books.

Professr O. C. Johnson gave 'A New Test for Nickel,' which consists of the treatment of the washed precipitates of nickelic and cobaltic oxides with potassium iodide. The presence of nickel is indicated by the liberation of iodine.

Dr. J. H. Kastle reported 'On the Occurrence of Barium and Strontium' in a large number of Kentucky and Ohio limestones. He drew out the point that where one metal of a triad is present in large quantities the other members of the series are invariably also present.

'The Estimation of Iron and Aluminum in Natural Phosphates,' H. W. Wiley and F. P. Veitch.

'A Study of the Tellurides,' Cabell Whitehead.

'Magnetic Ferric Oxide,' W. L. Dudley.

'The Action of Various Bases on Metallic Arsenites,' C. Wellington.

'The Action of Chromic Acid on Hydrogen,' C. L. Reese.

'The Action of Soft Waters on Metals,' Ellen H. Richards and Willis R. Whitney.

'A New Method of Standardizing Hydrochloric Acid,' F. K. Cameron and J. A. Emery.

Dr. C. Loring Jackson, in his paper entitled 'Certain Peculiar Reactions of the Tribromnitrophenols,' gave an account of his work on the action of sodium malonic ester, sodium acetoacetic ester and sodium ethylate on tribromnitrophenols and related substances with a view to determining why the bromine is replaced by hydrogen. Dr. A. B. Prescott's paper, 'On Certain Alkaloidal Periodides and the Volumetric Estimation of Alkaloids as Higher Periodides,' gave probably the highest possible periodides, viz., triiodide of morphine hydroiodide, hexaiodides of strychnine, brucine and aconitine hydroiodides, and the octoiodide of atropine hydroiodide. Dr. M. Gomberg

reported on 'A Periodide of Bromtriphenylmethane,' the only organic perhalide destitute of any element of the nitrogen family, except Victor Meyer's iodonium perhalide and Kastle's sulphonperiodide.

'On Tetraphenylmethane,' M. Gomberg.

'Hydrazo and Azo. Derivatives of Tetraphenylmethane,' M. Gomberg and A. C. Campbell.

'Camphoric Acid; Synthesis of the Neighboring Xylic Acid,' W. A. Noyes.

'The Propyl Phosphines,' Peter Fireman and E. G. Portner.

'The Action of Ethers on Phosphonium Iodide,' Peter Fireman and Ernestine Fireman.

'The Oxidation of Formic Aldehyde by Hydrogen Peroxide,' J. H. Kastle.

Dr. Charles F. Mabery reported a continuation of his great work on petroleum. In one paper, on the 'Unsaturated Hydrocarbons in Canadian Petroleum,' with W. O. Quayle, he stated that he had separated compounds containing seven, eight, nine and ten carbon atoms; a regular series of sulphur compounds following the type of  $C_nH_{2n}S$  beginning with  $C_9$ . Some sulphoxides according to the type  $C_nH_{2n}SO_2$  were formed from these compounds. In continuing his work with E. J. Hudson 'On the Constituents of California Petroleums' from different sources he found in some large amounts of aromatic hydrocarbons, benzol, toluol, xylols, etc., and smaller amounts of naphthene; in others the reverse was the case. Dr. Mabery also gave a paper 'On the Constituents of Commercial Paraffine' and succeeded in separating, by distilling under reduced pressure, a series of hydrocarbons according to the type of  $C_nH_{2n+2}$  beginning with  $C_{14}$  up to  $C_{20}$ . Working with H. L. Schrom, he obtained only negative results in his 'Efforts to add Hydrogen to Acetylene.' Sodium, amalgam, aluminum, and zinc with sulphuric acid, electrolysis and passing a mixture with hydrogen

from zinc and sulphuric acid over heated platinum sponge.

'Oxy-induline—a New Blue Dyestuff,' S. P. Mulliken and W. Kelley. This compound,  $C_{36}H_{26}N_4O_4$ , is readily formed by heating amidophenol hydro-chlorate. Sulphonated it is a fast and direct blue dyestuff.

'The Benzaldoxines,' F. K. Cameron.

'On True and Bis-Nitroso Compounds,' E. Kremers.

Dr. T. W. Richards gave an interesting historical review of the 'History of Physical Chemistry.' In one sense we are not wrong in looking on physical chemistry as a modern invention. While many of the fundamental generalizations are by no means recent, the sharp line drawn thirty years ago between physics and chemistry are but lately erased, and it is well accepted now that the same laws governing one class of phenomena are applicable as well to the other. Boyle, in the seventeenth century, discovered the law of the contraction of gases; Lavoisier forced the idea of the conservation of mass upon the scientific world. Dalton, Avogadro, Ampere, Gay-Lussac, Dulong and Petit, Davy and Faraday made great additions to our physico-chemical knowledge. Julien Robert Meyer and Helmholtz acquired a knowledge of conservation of energy. There were Hittorff's researches on electrolytic conductivity. Wilhelmy, forty years ago, worked on the speed of reactions along the lines suggested by Wentzel and Berthollet. The observations of these *savants* were used as a basis a decade later by Guldberg and Waage, when they promulgated the law of mass action as a result of the study of the progress and equilibrium of chemical change. Then why should it be regarded as new?

The growth of physical chemistry has not been commensurate with that of the other divisions of the science for several reasons, one of which was the necessity for dealing with the little understood subject of solu-

tions. Van't Hoff having shown that substances in solution follow the same laws governing the aëriiform state, and Arrhenius having explained the difference between solutions conducting electricity and non-conductors, the progress has been very rapid in the last ten years. Professor Richards attributed another cause as summed up in the word 'prejudice.' "Not only have untenable theories been held long after their time, but whole fields of study have been neglected by most chemists and physicists because they lay on the border line between the two sciences."

While higher mathematics is a most valuable instrument for a physical chemist, there is a serious danger of accurate mathematical processes leading to wholly erroneous conclusions because of incomplete or inaccurate data. One must be an accomplished physicist, chemist and mathematician to obtain the highest results in modern theoretical chemistry, and the number of men having time to acquire the necessary knowledge can never be large. Attention was called to the excellent laboratories of Nernst at Göttingen and Ostwald in Leipsic, and it was regretted that America did not have men devoting themselves to pure science.

Dr. E. C. Franklin, in his paper on 'Some Properties of Liquid Anhydrous Ammonia,' showed that ammonia resembles water closely in all the properties which give water its unique position as a solvent. It is next to water as a general solvent for salts; there is a close resemblance in the power of dissociating electrolytes, some salts conducting even better in an ammonia than in a water solution. It forms ammonia of crystallization. Except water, its heat of volatilization is greater than that of any other liquid. Its specific heat is as great as water.

'The Solubility of Di-ionic Salts of Weak Acids in Solutions of Stronger Di-ionic Acids,' A. A. Noyes and David Schwartz.

'The Solubility of Di-ionic Acids in Solutions of Di-ionic Salts of Other Acids,' A. A. Noyes and E. S. Chapin.

'The Solubility of Tri-ionic Bases in Solutions of Di-ionic Salts of Weak Bases,' A. A. Noyes and E. S. Chapin.

'The Solubility of Iodine in Dilute Potassium Iodide Solutions,' A. A. Noyes and L. J. Seidensticker.

Dr. A. A. Noyes, in this series of papers on 'Solubility,' showed that by means of equations the solubility of a substance in the presence of another can be calculated and so predicted.

'The Rate of Reaction between Silver Acetate and Sodium Formate; A Reaction of the Third Order,' A. A. Noyes and George T. Cottle.

'On the Influence of Silicon on the Heat of Solution of Coke in Cast Iron,' E. D. Campbell and W. E. Hartman.

'Passage of Bubbles through Media of Different Densities,' C. Gilbert Parker.

'Some Boiling-Point Curves,' F. K. Cameron and E. F. Thayer.

'Photographic Reproduction of Color,' Romyn Hitchcock.

'Sixteenth Annual Report of Committee on the Bibliography of Chemical Literature,' of which Dr. H. Carrington Bolton is Chairman. This report has been printed in SCIENCE.

The Sub-section of Physiological Chemistry met Friday afternoon in Room 8 Boylston Hall, Harvard University, a number of visiting physicians being present.

Dr. E. E. Smith, of New York, who was in charge of this division of the subject, gave the leading paper on 'American Research in Physiological Chemistry.' The beginnings of the application of chemistry to physiological research are twinned with the life of the American Association. It was inaugurated in 1842, when Meyer pointed out the valuable discoveries of Joule, Grove and Helmholtz in the domain of physics to

the physiologists. Von Liebig's 'Animal Chemistry,' edited for the American profession by J. M. Webster, was the first important publication in America in this line, although in 1825 Dr. Beaumont, U. S. A., had obtained for the first time pure gastric juice in treating a gastric fistula from a gunshot wound. Dr. Caldwell, of Louisville, ridiculed Liebig's material views of the body as a 'corporeal stove for burning oxygen.' In the forties animal heat attracted the attention of physiologists, many of whom maintained that if the lungs were the stove the lungs should be hotter than the other parts of the body. Austin Flint (1862) found stercorin in human feces and that it differed from cholesterin by only two hydrogen atoms.

In 1869 Atwater prepared an essay on the composition of the American maize. Twenty-five years ago this same worker, in an address before the Maine State Board of Health, gave out the modern ideas of nutrition. All are well aware of the valuable work done now in various parts of the country by Dr. Atwater, or under his direction, upon the dietaries of people of different occupations in various localities. Aside from the scientific value of such observations, the economics of the question deserve the most careful consideration. Dr. Atwater has concluded that our national dietary is one-sided, and as the food production of the United States is out of balance, we should make use of a larger proportion of fuel materials, as fats and carbohydrates.

Probably the greatest problem of interest now is the study of proteids. The imperfect methods of separating these complex bodies have been greatly improved by Mallet and Wiley by the use of various saline solvents and precipitants, especially phosphomolybdic acid and bromine. Chittenden's work for the past fifteen years, Osborne's new nomenclature and crystal-



lization of vegetable proteids, and Hofmeister's separation of crystalline animal proteids, have yielded interesting conclusions in regard to the physiology of germination and plant growth in general.

Among the earliest metabolism experiments reported were those of Flint, who concluded that the secretion of urea was increased by muscular exertion. These ideas have been verified by subsequent investigations.

During the last few years the chemical factors causing certain diseases have been studied. Some claim that some complaints are due to increased presence of uric acid in the blood. Herter says that this acid is the result rather than the cause. Rachford presents evidence to show that the symptoms of toxicity are expressions of leucomaine poisoning dependent upon defective elimination. The importance of the subject is exhibited by the foundation and organization of the Institute of Pathology of the New York State Commission of Lunacy and the recent establishment of a professorship in pathological chemistry in the University and Bellevue Hospital Medical College, New York.

American contributions to physiological chemistry have hitherto been scattered in journals of chemistry, physics, medicine and general science at home and abroad. There are two journals published now in America dealing directly with the subject, *The American Journal of Physiology* and *The Journal of Experimental Medicine*.

Dr. S. Bookman, in his paper on 'Studies in Epilepsy; a Contribution to the Subject of Metabolism in Nervous Diseases,' gave conclusions based on chemical examination of stomach contents, blood and urine, together with urotoxic and serotoxic determinations in four cases. His other paper was on 'Investigations of the Nature of the Nissl Granules.' 'Proteids of the Brain' was Dr. P. A. Levene's paper.

'Experiments on the Metabolism of Matter and Energy in the Human Body,' by W. O. Atwater and F. G. Benedict.

'Experiments on the Metabolism of Alcohol in the Human Body,' by W. O. Atwater and F. G. Benedict, provoked not a little discussion, for, from the experiments reported, alcohol is a heat-producing food.

'On the Availability of Nutrients of Food Materials,' by W. O. Atwater and A. P. Bryant.

'A Dietary Study of a Bicycle Racer,' by W. O. Atwater and A. P. Bryant. The subject studied was Miller, the six-day champion racer of the world.

Changes in the ripening of cheese are usually attributed to micro-organisms, but Drs. S. M. Babcock and H. L. Russell, in a paper on 'The Properties of Galactase; a Proteolytic Ferment of Milk,' attributed the conversion of insoluble casein of a green cheese into peptones and other soluble proteids in ripened cheese to the important enzyme named in the title of the paper. Galactase appears to be allied to trypsin and is more abundant in cream, being precipitated by absolute alcohol. It is present in all milks; sheep, goat, horse, hog, buffalo, burro and human.

'Urinary Acidimetry and Alkalimetry,' Heinrich Stern.

'The Normal Degree of Urinary Acidity,' Heinrich Stern.

Dr. H. A. Weber, who was in charge of the subject of Agricultural Chemistry, gave a paper on 'Light: a Factor in Sugar Production.' The sugar content of plants is dependent upon climatic conditions, location and proximity to large bodies of water. For plants having short period of vegetation higher latitudes are more favorable, other things being equal.

'The determination of Starch in Agricultural Products,' J. B. Lindsey.

'A Note on the Growth of Lupins on Calcareous Lands,' E. W. Hilgard.

'Some of the Important Results of Recent Chemical Investigations of Plant and Animal Cells,' E. A. de Schweinitz.

'Composition of Ohio Wines,' A. W. Smith and Norman Parks. The ratio of glycerol to alcohol in native wines is usually taken as 7-14 to the 100. From pure wines made by the authors it varies from 3.9 to 11.8 to the 100 with an average of 5.

'The Determination of Turbidity of Water,' W. P. Mason.

'Efficiency of the Elmira Filtering Plant,' W. P. Mason.

Miss Isabel F. Hyams and Mrs. Ellen H. Richards, in presenting their paper, 'On the Composition of *Oscillatoria prolifica* (Greville) *O. rubescens* (de Candolle) and its Relation to the Quality of Water Supplies,' exhibited samples of the blue-green algæ found in Jamaica Pond, Boston, during the months of May, June and July. The algæ seem to be identical with that found in Lake Geneva in 1834-6, and later in Lake Mérat. During the growth of this moss the water assumes a brownish-red appearance, and on a hot, still day it separates out as a cream, which is easily driven by the winds upon the rocks, where it decays, giving off a disagreeable, fetid odor. While numerous substances were extracted from the moss, no ill effect is known which may be attributed to this source.

'The Le Seuer Electrolytic Process for the Production of Caustic Soda and Bleaching Powder,' read by Dr. C. L. Parsons, depends upon iron bars supporting a wire gauze as a diaphragm and the use of platinum-iridium anodes bound up in glass. In another paper, 'A Review of the Electrolytic Processes for the Production of Caustic Soda and Bleaching Powder,' by the same author, it was claimed that the process described would replace the Castner-Kellner and other processes on account of economy and efficiency.

'The Alum Question in Water Purification,' E. G. Smith.

Dr. C. F. Mabery and Mr. K. Landgrebe stated that 'The Effect of an Electrolytic Bath on the Tanning of Leather' was the reduction of the time consumed, and they observed that the percentage of nitrogen was lower in leather so tanned.

'Some Records in the Year's Progress in Applied Chemistry,' Wm. McMurtrie.

'The Progress in Utilization of City Garbage, with Special Reference to the New Plant in Boston,' Bruno Terne.

'On the Removal of Hardness from Water for Boiler Purposes,' C. F. Mabery and E. B. Baltzly. All kinds of hard water have from 90-98 per cent. of the lime present and all suspended matter are precipitated cold by treatment for twenty-four hours with half the calculated amount of sodium aluminate.

'New Process for the Commercial Production of Oxygen and its Industrial Applications,' Romyn Hitchcock.

The meeting was most successful in every way.

CHAS. BASKERVILLE,  
Secretary.

UNIVERSITY OF NORTH CAROLINA.

PHYSICS AT THE BOSTON MEETING OF THE  
AMERICAN ASSOCIATION FOR THE AD-  
VANCEMENT OF SCIENCE (I.).

SECTION B of the American Association was organized with Vice-President F. P. Whitman in the Chair. His vice-presidential address, on color-vision, printed in the issue of SCIENCE for September 9th, was well received and constitutes a *résumé* of the subject of great value.

The program of the section included fifty titles of papers, of which forty were read before the section. Many of these papers were of very high order and almost every one of them was creditable and interesting.

*The Measurement of Thermal Conductivity in Iron.* By PROFESSOR E. H. HALL, Cambridge, Mass.

THE author pointed out that the method in which thin plates are used is unsatisfactory owing to the difficulty of determining the difference of temperature of the two faces. He obviates this by copper-plating the two faces of his iron plate and by using the copper-iron thermocouples thus formed for determining the temperature difference. He finds that the conductivity of iron increases as the temperature is decreased at the rate of about one per cent. for eight degrees Centigrade.

*On the Magnetic Deflection of Diffusely Reflected Cathode Rays.* By PROFESSOR ERNEST MERRITT.

*On the Electrical Properties of the Vapor from the Arc.* By PROFESSOR ERNEST MERRITT and O. M. STEWART.

PROFESSOR MERRITT finds that diffusely reflected cathode rays are deflected by a magnet to the same extent as the same rays before reflection. Professor Merritt and Mr. Stewart find that the vapors from the electric arc produce electrical discharge in a manner similar to the action of a gas which has been exposed to X-Rays. Vapors from the negative carbon discharge negative charges more readily than positive charges.

In their report on the Velocity of Light in the magnetic field Professors E. W. Morley, H. T. Eddy and D. C. Miller described their interferometer, the two optical paths of which consist of tubes of carbon bisulphide surrounded by very large magnetizing coils. These coils were wound in halves which could be connected differentially or directly at will. It was found that the velocity of light in  $CS_2$  is not altered by one part in sixty millions by a magnetic field of such intensity as to rotate the plane of polarization  $180^\circ$  in 60 cm.

*A Study of Galvanic Polarization.* By BARRY McNUTT, South Bethlehem, Pa.

THE author finds that the polarization of a Cu— $CuSO_4$ —Cu cell (and the same is true of cells of silver and of zinc) is not zero with infinitesimal (?) current.

*A Lecture Room Experiment in Electrostatics.* By PROFESSOR W. S. FRANKLIN, South Bethlehem, Pa.

THE author exhibited an experiment illustrating the instability of electrified liquid films. A brass ladle with a sharp lip is nearly filled with melted rosin; it is then electrified, by joining it with an electrical machine, and tilting until the rosin runs in a thin layer over the lip, when it is blown out in a cloud of silky threads highly electrified.

*The Most Efficient Thickness of Transformer Plates.* By PROFESSOR F. BEDELL, R. M. KLEIN and T. P. THOMPSON, Ithaca, N. Y.

ON plotting the curve showing the relation between the thickness of the plate and the total loss due to hysteresis and eddy currents it is found that the curve has a broad, flat minimum extending from about 10 to 15 thousandths of an inch in thickness of the plate.

*Proposed Methods of Determining the Frequency of Alternating Currents.* By KARL KINSLEY, Falls Church, Va.

MR. KINSLEY advised using a clamped, free bar provided with an adjustable rider and set in vibration by an electro-magnet actuated by the current to be studied.

*A New Gas.* By CHARLES F. BRUSH, Cleveland, Ohio. (Printed in SCIENCE for October 14th.)

*Polarization and Internal Resistance of the Voltaic Cell.* By DR. KARL E. GUTHE, Ann Arbor, Mich.

*Graphical Treatment of Mutually Inductive Circuits with Special Reference to the Case of Variable Frequency.* By PROFESSOR H. T. EDDY, Minneapolis, Minn.



*The Hysteresis of Iron and Steel at Ordinary Temperatures and at the Temperature of Solid Carbon Dioxide.* By A. M. THIESSEN, Ithaca, N. Y.

It was found that the hysteresis loss for constant magnetizing fields increases with the temperature if the field is weak, but the opposite is the case when the iron is nearly saturated.

*Some Determinations of Dielectric Strength.*

By PROFESSOR THOMAS GRAY, Terre Haute, Ind.

STEP-UP ring transformers were used and the potential difference was determined by an electrometer. It was found that the dielectric strength for air is the same for alternating currents of ordinary frequency as it is for static charges.

*A Study of Standard Meter Scales ruled on Nickel, Silver and Glass.* By PROFESSOR D. C. MILLER, Cleveland, Ohio.

AFTER an exhaustive study of scales of various kinds Professor Miller concludes that nickel scales are far superior to those in common use, and indeed as good as platinum iridium, except that they have a somewhat higher coefficient of expansion. His nickel bar, made by the Geneva Society, is very accurately divided, and he has calibrated it throughout by the international method.

*An Instrument for Measuring Radiance.* By PROFESSOR KNUT ANGSTROM.

THE instrument was exhibited by Mr. E. S. Ferry, and consists essentially of two bolometer strips, one of which is heated by the radiance to be measured and the other is heated to the same temperature by an electric current, from which the absolute value of the radiance may be calculated.

*A Redetermination of the Ampere.* By GEO. W. PATTERSON and KARL E. GUTHE, Ann Arbor, Mich.

THE authors used an electro-dynamometer the moment of whose coil was bal-

anced by the torsion of a wire of small elastic fatigue. The work seems to have been done with extraordinary care and gives 0.0011192 grams per sec. per ampere for the electrochemical equivalent of silver. This reconciles the difference between Rowland's value for the mechanical equivalent of heat and that obtained by electrical methods. The paper occasioned a great deal of favorable comment.

*Progress in the Exploration of the Air with Kites at the Blue Hill Observatory.* By A. LAWRENCE ROTCH, Director.

*On the Osmotic Pressure of certain Ether Solutions and the Validity of the Boyle-Van't Hoff Law.* By PROFESSOR H. M. GOODWIN and GEO. K. BURGESS, Boston, Mass.

It was shown that the Boyle-Van't Hoff law holds as a first approximation only.

*On the Dielectric Constant and Electrical Conductivity of Liquid Ammonia.* By PROFESSOR H. M. GOODWIN and MAURICE DE KAY THOMPSON, Boston, Mass.

It is found that the dielectric constant of liquid ammonia is less than it is for water, while the electrical conductivity of solutions of salts in ammonia is greater than it is for solutions of the same salts in water.

The two reports and five papers following were read in joint session with Section A.

*Report on the Recent Progress in the Dynamics of Solids and Fluids.* By PROFESSOR ERNEST W. BROWN, of Haverford College, Pa. [To be printed in SCIENCE.]

*Report on the Recent Progress in the Mathematical Theory of Electricity and Magnetism.* By PROFESSOR ARTHUR G. WEBSTER.

*The Mass and Moment of Inertia of the Earth's Atmosphere.* By PROFESSOR R. S. WOODWARD, Columbia University, New York.

PROFESSOR WOODWARD pointed out our ignorance of the necessary data and gave the results arrived at by making various hypotheses.

*Temperature and Vapor Gradients in the Atmosphere.* By PROFESSOR F. H. BIGELOW, Washington, D. C.

*Two New Forms of Apparatus for Measuring the Acceleration of Gravity.* By PROFESSOR R. S. WOODWARD.

THE author suggested the use of the vibrations of a weight hung from a helical spring. Professor T. C. Mendenhall suggested the use of a flat ring as a pendulum, the only linear measurement required being the external diameter of the ring.

*The Structure of Cyclones and Anticyclones.* By PROFESSOR F. H. BIGELOW.

*The Gravitation Constant and the Mean Density of the Earth.* By PROFESSOR R. S. WOODWARD.

PROFESSOR WOODWARD pointed out a new form of the relation between these two quantities.

*On the Relative Brightness of Pigments by Oblique Vision.* By PROFESSOR F. P. WHITMAN, Cleveland, Ohio.

PROFESSOR WHITMAN used the flicker photometer and found that the brightness at the red end of the spectrum decreases as the vision becomes more oblique, while the opposite is true (but to a less extent) at the violet end. The brightness of yellow-green is nearly independent of the angle.

*A New Instrument for the Measurement of the Intensity of Sound.* By PROFESSOR A. G. WEBSTER and MR. B. F. SHARPE.

THE method consists in measuring, by means of an interferometer, the amplitude of vibration of a thin glass plate. The interference fringes are photographed on a revolving drum. The constants of the instrument can be experimentally determined and the intensity of the sound can be calculated in absolute terms.

*Exhibit of an Automatic Mercurial Air Pump designed by Professor E. W. Morley.* By PROFESSOR D. C. MILLER.

THE peculiar advantages of the pump are that it need not be situated near the automatic controller, and that the mercury does not come in contact with rubber. It can be actuated with a water pressure of 20 pounds per square inch and can produce a vacuum of 1-500,000,000 of an atmosphere.

*An Apparatus for demonstrating in Alternating Currents the Change of Phase due to either Inductance or Capacity.* By PROFESSOR SIDNEY T. MORELAND, Lexington, Va.

*An Apparatus for determining Coefficients of Induction.* By PROFESSOR SIDNEY T. MORELAND.

THIS apparatus consists of two coils at right angles, producing a rotating magnetic field when alternating currents of different phase are sent through the two coils. A copper cylinder is suspended in this rotating field and indicates the phase relations of the two currents.

*An Improved Method for rating Tuning Forks.* By J. O. REED, PH.D., Ann Arbor, Mich.

THE method is a modification of that used by Professor Michelson, but instead of using an electric spark Dr. Reed employs the flash of light from a mirror rotated by a secondary pendulum, which is in turn compared with the standard clock.

*A New Chronograph and a Means of Rating Tuning Forks.* By PROFESSOR A. G. WEBSTER.

THE chronograph is actuated by a small motor regulated by a tuning fork.

*A Geometrical Method for Investigating Diffraction by a Circular Aperture.* By PROFESSOR A. G. WEBSTER.

PROFESSOR WEBSTER obtains a kind of 'ratchet' Cornu's spiral for this case of diffraction, that is a spiral having cusps.

*Study of Elastic Fatigue by the Time Variation of the Logarithmic Decrement.* By PROFESSOR J. O. THOMPSON.

*Photographic Studies of the Electric Arc.* By N. H. BROWN, Ithaca, N. Y.

*On the Efficiency of Condensers.* By PROFESSOR E. B. ROSA and ARTHUR W. SMITH, Middletown, Conn.

THE authors give results determined by their resonance method, which was described at the Detroit meeting.

*A Calorimetric Determination of the Energy Dissipated in Condensers.* By PROFESSOR E. B. ROSA and ARTHUR W. SMITH.

*The Effect of Fibrous Structure in Iron on its Change of Length when Magnetized.* By E. RHOADS, PH.D., Baltimore, Md.

*Notes on the Effect of Silicon on the Magnetic Permeability of Iron.* By PROFESSOR F. C. CALDWELL, Columbus, Ohio.

IT was found that the permeability increases with the amount of silicon present in the iron.

*On the Measurement of Electrical Oscillations of Short Period and their Absorption by Water.* By PROFESSOR A. D. COLE, Granville, Ohio.

THIS is a continuation of the work which was reported by Professor Cole to Section B at Buffalo.

*An Acoustical Micrometer.* By J. O. REED, PH.D., Ann Arbor, Mich.

ITS principle consists in measuring the amplitude of vibration of a stretched membrane.

*Polarization in the Zn—H<sub>2</sub>SO<sub>4</sub> Cell.* By PROFESSOR W. A. ANTHONY, New York City.

AFTER an extended research into the effect of saturating the acid with hydrogen, oxygen and carbon dioxide, Professor Anthony concludes that what is called polarization is not due to the accumulation of hydrogen, but to the fact that the oxygen originally dissolved in the acid and condensed on the plates has been used up.

*The Heat of Fusion of Ice Determined in Electrical Units.* By PROFESSOR E. L. NICHOLS, Ithaca, N. Y.

*The Electrical Resistance of Lead Amalgams at Low Temperatures.* By G. W. GRESSMAN, Ithaca, N. Y.

THE most striking fact reported in this paper is the sudden decrease in resistance upon solidification, the resistance of the solid amalgam being sometimes as low as one-fifth of the resistance of the fluid amalgam at its freezing point. If the thermo-electrical explanation—based on heterogeneity—of excessively high resistance of alloys is correct one would expect an increase of resistance upon solidification, for it is then that the alloy becomes heterogeneous.

N. ERNEST DORSEY,  
Press Secretary.

#### THE ADVANCE OF PSYCHOLOGY.\*

THE American Association for the Advancement of Science, when it first met fifty years ago, had no place for anthropology nor for psychology. Science has its origin in the practical needs of society. In a new country of great area and rich resources the energies of its people were directed to invention and exploration. The spirit of Franklin led to the development of railways, steamboats and telegraphy, to the building of cities and the search for mines.

But not only in America and in the case of the anthropological sciences have fifty years brought great changes. Science has become a leading factor in modern life by the rapidity rather than by the duration of its growth. Our own revered Dr. Hall might have talked with Herschell, who could almost have touched the hand of Newton. Newton was born the year that Galileo

\*Address of the Vice-President of Section H—Anthropology—of the American Association for the Advancement of Science, August, 1898.



died. If Copernicus had lived to extreme old age he might have handed the *De Orbium Cælestium Revolutionibus* to Galileo. While the whole history of science is thus nearly spanned by five lives, modern science is scarcely older than our Association. It was only in the decade of its foundation that the doctrine of the conservation of energy was announced, while the *Origin of Species* was published in the year of our eleventh meeting. If the physical sciences, as we now understand them, are scarcely more than fifty years old, and the biological sciences are only forty years old, the anthropological sciences are still younger. Perhaps these are now in the condition of the physical sciences before they had become truly exact, of the biological sciences before they had become truly genetic.

It is easy to prophesy after the event, and from our present point of view science in its history appears to have followed a necessary course. The phenomena of the physical world are stable and readily subject to experiment and measurement; their control is essential to material progress. It is, therefore, no wonder that the physical sciences should have preceded the biological sciences in their development. Far more complex, transient and inaccessible to experiment even than the phenomena of living beings are men, they themselves and their deeds—sciences of these things must come late. As man has been evolved from simpler forms of life, and these were preceded by a lifeless earth, so the sciences dealing with man, with life and with matter must be based one upon the other. The history of science is, therefore, full of promise for the student of anthropological science. We may grant the past to others and claim the twentieth century for our heritage. Perhaps our Copernicus, our Newton, our Lavoisier, our Darwin is one of the younger members of this Section.

It may, however, be that the subject-matter of the anthropological sciences is such that they will proceed without catastrophe. The form of the earth is altered by earthquakes on occasion, but every day it is molded to a greater degree by less obtrusive agencies. In the making of the anthropological sciences by the collecting and arranging of facts, by discovery and by generalization, we have every reason to be satisfied with the part taken by America and by this Association. In many sciences we must at once yield the leadership to older nations. In the youngest of the sciences we at least stand on terms of equal service. It was perhaps by special providence that last year's meeting of our Association was presided over by an anthropologist, but this year we chose to celebrate our fiftieth anniversary under a member of this Section. That this Section should have supplied three of our last five presiding officers and our permanent secretary for twenty-five years; that the British Association should have come to America to establish its Section of Anthropology and on its second visit should have chosen an anthropologist for its president—these things we may at least regard as an omen of the place of anthropology in the science that is to be and of the place of America in anthropology.

While anthropology, largely owing to the richness of the material at hand and to the great Bureau of American Ethnology established to investigate this material, has come to such fruition in America, psychology has also shown great vitality. Unlike anthropology, psychology is distinctly a university discipline. For reasons chiefly theological, ethical and educational, mental and moral philosophy had been taught from the foundation of our colleges by the president of each institution to all students. It happened that at the same time that psychology had developed into a science, the college president became an executive

officer, no longer chosen as a matter of course from the clergy, having neither time nor training for the teaching of mental science. There was thus an empty place which the modern psychologist was prepared to fill. Further, the rapid development of the college into the university with elective courses permitted psychology to compete on equal terms with the older sciences, and the result has been its secure establishment in the university. Indeed, psychology, touching with one hand philosophy, the humanities and the historical and political sciences, while with the other hand it reaches toward the natural and exact sciences, bids fair to become central. Thus, at Harvard, Professor Münsterberg's elective course in empirical psychology was this year followed by 365 students. At Yale Dr. Scripture's course in physiological and experimental psychology was elected by 138 students. There were last year given by American universities 18 doctorates with psychology as the major subject—more than in any science except chemistry, six times as many as in astronomy and nine times as many as in anthropology.

Psychology, though its recent development has been so rapid, is not a new science; it should rather be regarded as one of the oldest of the sciences. Under the great dynasty of philosophers—founded in Greece, not extinct even during the Dark Ages, re-established after the Renaissance—all the sciences were developed. From Aristotle to Kant the history of philosophy is in large measure the history of science. But as the domain of knowledge became too great to be ruled by a single mind it must needs be divided into the principalities that we call the sciences. From the beginning psychology has been the favored nursling of philosophy, and, as the other sciences were taken from it, all the more did it cherish that which was left. In Great Britain Locke, Berkeley and Hume and their Eng-

lish and Scottish successors to the present time have been at once students of philosophy, and of psychology. The same may be said of Herbart, Lotze, Wundt and many more in Germany and in France. In our own country to-day we find many of our leaders—James, Ladd, Royce, Dewey, Fullerton and others—professing equally philosophy and psychology.

Psychology, under the guidance of philosophy, became at times somewhat schematic and unreal, though never I think unfruitful or regressive. It needed, however, to be cross-fertilized with the natural sciences. These sciences, in their development, could not ignore the senses and the mind. Perceptions are parts of a physical system, but they are also parts of an individual consciousness. Newton not only analyzed light, but also named seven colors; Dalton found that he was blind to certain of them; Young invented a theory to account for their combinations; von Helmholtz reviewed the phenomena in one of the greatest of books. Physiology on its side could not study the senses and brain while ignoring the functions that they subserve, and it was found that the methods of natural science could be applied in psychology. The zoologist could not neglect the mental life of animals and the place of consciousness in evolution. Darwin wrote not only *The Origin of Species*, but also *The Descent of Man* and *The Expression of the Emotions*, and was the first to study the development of the child's mind.

The subject-matter having been supplied by philosophy and the methods by natural science, the way was made ready for the establishment of a science of psychology. This we owe largely to the intellectual patience of Germany, tired at last of the Hegelian metaphysics. Lotze published his *Medizinische Psychologie* in 1852; Fechner his *Elemente der Psychophysik* in 1860; Wundt his *Menschen und Thierseele* in 1863, and his

*Physiologische Psychologie* in 1874. Lotze and Wundt were doctors of medicine; Fechner was a professor of physics; they were all deeply interested in philosophy. Psychology, as pursued to-day, is deeply indebted to these three, perhaps chiefly to Wundt, who, continuing his services, founded in 1879 the first laboratory of psychology, and established in 1883 a journal for the publication of its investigations. Following and leading this psychological movement we find in Germany men such as Stumpf, Lipps, Ziehen, Müller, Ebbinghaus and many more. One of them—Münsterberg—has come to us, while Höffding, of Denmark, may be included in the same group. Physiologists, such as Hering, Aubert, Preyer, Flechsig, Exner and von Kries, and physicists, such as von Helmholtz, Mach and König, may reasonably be claimed, in part at least, for psychology.

In France a philosopher, as Cousin, or a man of letters, as Taine, may have accomplished somewhat, but modern writers and workers, as Ribot and Binet, have been largely influenced by Germany. France has, however, made two independent contributions of importance, though in both cases chaff has been mixed with the grain. These are, on the one hand, abnormal and pathological psychology and, on the other hand, individual and social psychology. In Italy the names of Lombroso and Mosso remind us of work in criminology and in physiology that has become important for psychology, as is also the case with the histological work of the Spaniard, Ramon y Cajal. In Russia performance waits on promise.

Great Britain has developed a modern psychology without breaking with its traditions. It has always been a land of great individuals, and Locke, Berkeley and Hume have found worthy successors in Bain, Ward and Stout, to mention only three living psychologists belonging to

three different generations. Darwin, Huxley and Spencer, while establishing the theory of evolution, gave mind its due place, Spencer having concerned himself especially with mental and social evolution. Romanes and Lloyd Morgan have directed attention to the study of animal intelligence, while Galton's contributions to anthropometry and heredity have exhibited great originality. Experimental psychology has not made much headway in Great Britain. They have let us take from them Titchener; so he must count for America. The first laboratory, at Cambridge, was founded by me, and maintains a humble existence. Within a year a laboratory has been founded at University College, London, and Oxford has at least awakened to the existence of experimental psychology to the extent of decreeing this summer that it shall *not* be taught under a newly established lectureship of mental philosophy.

This American Association is naturally most concerned with what has been accomplished for psychology in America. The history of psychology here prior to 1880 could be set forth as briefly as the alleged chapter on snakes in a natural history of Iceland—"There are no snakes in Iceland." The eminence of the theologian Jonathan Edwards is witness to the lack of any psychologist. We had only text-books by college presidents setting forth Scottish realism. Porter, of Yale, gave us the best of these books, but McCosh, of Princeton, performed a greater service by placing the aegis of theological conservatism over both organic evolution and experimental psychology.

But the land lay fallow and twenty years ago the seed was sown. James, at Harvard, began the publication of a series of striking articles, culminating in the issue, in 1890, of *The Principles of Psychology*, a work of genius such as is rare in any science or in any country. Hall, in 1883, established in the



Johns Hopkins University the first American laboratory of psychology—the second in the world\*—since transferred to Clark University. The *American Journal of Psychology*, founded by him in 1887, shows the value of the work accomplished at Johns Hopkins and Clark, while the *Pedagogical Seminar* bears witness to his influence in stimulating interest in the child's development. Ladd published, in 1887, his *Elements of Physiological Psychology*, a work that has exerted great influence both here and abroad. It has been followed by a series of treatises on psychology that have never been equalled in range and thoroughness.

Under James, Hall and Ladd and in Germany there was then trained a second generation of psychologists, and we ourselves now have our students, a third generation. The second American laboratory was under my direction at the University of Pennsylvania. The first chair in psychology was there established and courses in laboratory work were there first given. This was only ten years ago. The work at Pennsylvania is continued under Witmer, while at Columbia we have since 1890 a laboratory and a range of courses in experimental, physiological and analytic psychology which may bear comparison with those of the other sciences. Baldwin carried modern psychology, himself enlarging it as he went, from Princeton to Lake Forest and thence to Toronto and back to Princeton. The laboratory established by him at Toronto is continued under Kirschmann, while at Princeton he has founded an efficient laboratory, and by his work on genetic psychology has brought our science into fruitful relations with zoology and sociology. Jastrow, at Wisconsin, stands forward

as a leader in experimental psychology having accomplished much for the advancement of the science and the diffusion of its results. In the latter connection may be mentioned the psychological laboratory under his direction at the Columbian Exposition and the fact that almost alone he has represented psychology in this Association.

The great services for psychology of James at Harvard, Hall at Clark and Ladd at Yale were not confined to their own publications, but were also directed toward building up strong departments. Harvard, with James, Münsterberg, Royce, Santayana, MacDougal and other men in closely related departments, surpasses every other university in the world in its opportunity for psychological study and research, and there is quite as much reason for German students to come to Harvard as for our students to go to Germany. Clark, where Sanford has charge of the laboratory, may almost be said to be a university for the advancement of psychology. The laboratory at Yale, under Scripture, has shown great activity and is able to publish annually a volume of researches. Cornell, under a president who is a student of philosophy and psychology, has robbed Great Britain of its best experimental psychologist, and under Titchener the laboratory stands quite to the front, while the courses in philosophy and psychology are especially well developed. Chicago early recognized the importance of psychology. Securing Dewey and Mead from Michigan and Angell for experimental work from Minnesota, in psychology, as in other departments, its development has been marvellous. Michigan and Minnesota have found other men to continue the work, while Stanford, California, Indiana, Iowa, Illinois and all the great State universities have established laboratories and given an adequate place to psychological courses.

\* It would be more correct to regard the laboratory established about the year 1875 by James in the Scientific School of Harvard University as the world's first psychological laboratory. It was, however, nominally under physiological auspices.

It would be possible for me to give other objective proofs of the progress of psychology—the establishment, in 1894, of a second journal, *The Psychological Review*, which during the first six months of the present year published some 900 pages, all we hope contributing to the advancement of psychology; the prominent place given to psychology in our journals of education, philosophy, general science and popular literature; the widespread amateur interest in child-study and psychical research; our Psychological Association, with a membership of 102, all engaged in advancing psychology—these and other witnesses for psychology might be called upon to testify, but the development of psychology in the university has seemed to me best deserving of extended comment. Until the State shall learn to care for those who do the most for it, until those who are engaged in advancing knowledge shall work for the State and be supported by the State our universities will be the centers for research, and the position of a science in the university will measure its opportunity and fruitfulness. Very significant for psychology, therefore, is its progress in the universities of America during the past twenty years.

My remarks have been confined to the externals of psychology. Its inner history, its present content, its future outlook are not subjects that can be readily brought up and dismissed in a few words. Psychology is the most complex of the sciences. I do not at all claim that it is the most important of the sciences. The human race got on without it very well and could doubtless continue to do so. Its practical applications do not compare in importance with those of many of the sciences; it is in a way lacking in great discoveries and universal laws. But, compared with psychology, a science such as astronomy may almost be regarded as naïve. The entire known performance of the solar system and of the

fixed stars since the time of the Chaldeans<sup>8</sup> is less complicated than the play of a child in its nursery for a single day. The stars are so far away, the telescopes are so big, eclipse expeditions proceed to such remote quarters of the earth, that the simplest items of information take on a dramatic interest. Atoms and molecules are so invisible, the ether is so intangible, we know after all so little about them, that it is easy to invent hypotheses that do not contradict our ignorance. The generalizations of physical science are, indeed, the greatest achievements of the human intellect, but the intellect, by which and for which these generalizations have been created, when itself made the subject-matter of a science, is complex beyond those sciences which are its offspring.

Psychology does not, of course, claim as its subject-matter all 'that is in heaven above, or that is in the earth beneath, or that is in the waters beneath the earth.' The physical and natural sciences, language, literature and the fine arts, industries and institutions have, it is true, their origin and end in the mind, but this does not turn them into departments of psychology. The physicist no more needs to concern himself with the mental processes leading to his discovery than does the hen with the processes preceding the laying of its egg. The kind of novel called psychological is by no means a product of science. The enjoyment of art decreases as we analyze its products. Scientific prevision and guidance have scarcely more to do with the rise and decline of institutions than with the rise and decline of the sun in the firmament.

Still I do claim that there is no department of knowledge or activity which does not have an aspect that concerns psychology, and while hitherto it is psychology which has learned from sciences preceding it in their development, the time will come, and perhaps has now come, when every

science must take into account the facts and theories of psychology. The increase of knowledge which has caused the creation of the separate sciences is now leading to further specialization, but not in the sense of one science more completely ignoring the others. Rather we have at present well established sciences, such as astrophysics, physical chemistry, biology and others which take their subject-matter from two or more of the older sciences. It is probable that students in increasing numbers will take up the inter-relations of psychology with other sciences. Indeed, this tendency is already well marked. Mathematics is necessary as a tool for psychology, while conversely several books have recently been published concerned with the psychological presuppositions of mathematics. The fundamental concepts of mechanics have been treated as mental products by Mach, Pearson and others. At the present moment the Vice-President is giving, before the Section of Physics, an address on the perception of light and color, while the same subject was chosen by Sir George Stokes last month for the subject of his address before the Victoria Institute. Physics is, however, leaving to psychology vision, hearing, etc., though in the meantime new departments, destined perhaps to become new sciences—represented by the great works of von Helmholtz, *Physiologische Optik* and *Tonempfindungen*—are being created, which draw their materials in equal measure from physics, from physiology and from psychology. Errors of observation, the personal equation, the relation between mental and physical intensity, are subjects where the investigations of the psychological laboratory must be applied in astronomy and the other physical sciences. Chemistry, geology and botany perhaps stand most remote from psychology. Still, if physiology is in large measure the chemistry of living tissues, chemistry may be brought into intimate

relations with psychology. Geology and anthropology are closely related, while physical geography is especially concerned with the relations of man to the earth. Many of the problems of evolution, so essential for psychology, are best studied in plants, and the applications of botany in agriculture, etc., are determining factors in the evolution of man.

Physiological psychology is already accepted as a distinct discipline, while zoology and psychology are equally intertwined. It is impossible to separate physical and mental evolution—witness the writings of Darwin, Spencer, Huxley, Romanes, Cope, Morgan and many more. Under the classification of this Association anthropology and psychology are included in one section. Several of our leading members would make psychology a branch of anthropology, while psychology regards ethnology and archaeology, on the one hand, and somatology, on the other, as contributing much to its subject-matter. Sociologists find it somewhat difficult to disentangle their field from that of psychology.

If we turn to the departments of knowledge not represented in this Association—the humanities—we find psychology to be a connecting link between them and the physical and natural sciences. If we regard the professions—medicine, law, theology, teaching, journalism—we find that their products when systematized into sciences give to psychology and take from it. Literature and the fine arts, both in their origin and in their end, may be studied as departments of psychology, though it does not appear that psychology has as yet been of great service to them.

I may illustrate the inter-dependence of psychology and other sciences by a definite example. Much is being written just now regarding the relation of consciousness to the brain. The question is: Do perceptions, thoughts, feelings, volitions stand in causal



interaction with the brain, or are they an epiphenomenon, accompanying changes in the brain but not influencing them? Are our ordinary actions complex reflexes due to physical stimuli and the structure of the nervous system, or are the changes in the brain that precede movements initiated and directed by consciousness? The question is one of facts, that should be settled by scientific methods; and the solution will by no means concern psychology alone. The two greatest scientific generalizations of the present century are the conservation of energy and evolution by survival of the fit. Now, if consciousness alters, however slightly, the position of molecules in the brain the fundamental concept of physical science must be abandoned. If consciousness have no concern in the actions of the individual we have one of the most complex results of evolution developed apart from the survival of useful variations, and the Darwinian theory has failed. Surely both the physicist and the biologist must watch the steps toward the solution of a problem that concerns them so nearly.

The world is one world; every part of it is in relation to every other part, and each part consists in these relations. As a hand cut off from the rest of the body is no longer a hand, as a man apart from other men is no longer a man, so each science and each scientific fact and law has its value and even its existence in its relation to the totality of knowledge and of life. Psychology has become an integral part of modern science; it gives and takes with a free hand. A parvenu among the sciences, it is self-conscious and knows its obligations and its limitations; but its position in the body scientific is henceforth secure.

I have said that psychology is in a way lacking in great discoveries and universal laws. If I were addressing an audience of psychologists it might be desirable to consider whether this is due to the subject-

matter or only to the immaturity of our science. Under present circumstances it is perhaps better in part to question my own statement. Columbus discovered a new world; Copernicus discovered innumerable worlds; but Descartes discovered, or at all events invented, the soul. Which after all was the greater scientific advance? Columbus did not foresee four hundred years of history, the present unequal conflict of a powerful nation with a declining civilization. Descartes' ideas of the relation of mind and body are not ours. But is not the very subject-matter of psychology one of the greatest discoveries of modern science? To unite strict idealism with strict materialism; to give consciousness its central place in the universe and yet to show that each change in consciousness is correlated with a change in the nervous system—this I claim to be a scientific generalization comparable to that of the conservation of energy or of organic evolution.

Minor but clear-cut discoveries in psychology have not been lacking—witness color-blindness, individual types of mental imagery, the dependence of emotion on reflex bodily movements, hypnotism, etc. Neither are quantitative formulas denoting relations among mental states or between mental and physical change lacking. Recent researches on subjects such as the perception of space, illusions of sense, color-vision, the time of mental processes, memory, fatigue and many more represent scientific advances as definite, interesting and important as those of physics or of zoology. Psychology has been able to adopt the quantitative methods of exact science and the genetic methods of natural science, while its older methods of description and analysis witness an insight and acuteness unrivaled by any other science.

I have said that the practical applications of psychology do not compare in importance with those of many of the other sciences.

Here again, while a society of psychologists might properly discuss the causes of this limitation, in an address confined to generalities, it may be more profitable to point out that daily life consists in the application of such psychological knowledge as is at hand. How could Bismarck and Gladstone direct contemporary history except by superior insight into the way men act and the methods of influencing their actions? What have Wagner and Browning done except excite interest and emotion? The conduct of every profession and of every business is chiefly based on the adjustment of thoughts, feelings and actions. Systems of government and education are simply methods for controlling and directing the human mind. Now, of course, all this is done by the rule of thumb entirely uninfluenced by psychology as a science. The savage who kills a bird with a stone is not thereby shown to be a zoologist and a physicist. Still he does have a kind of knowledge of the habits of animals and of the laws of projectiles, whence have developed the sciences which, in the course of time, have turned back to daily life those applications of science in which modern civilization consists. Whether the history of the material sciences will be repeated in the case of the mental and social sciences it is not possible to say or to gainsay. There are at present indications of the application of psychology in the treatment of diseases, in education and in other directions. Evolution, careless of the individual, has proceeded with boundless waste; certainly we are now interfering with its course for our benefit. It may be that some day the applications of material science will be subordinate to those of psychology.

These things lie on the knees of the gods. What the future will bring we do not know, but the past is ours. When we regard the fifty years of this Association or the century now ending we cannot fail to

see that it has been an era of science. German music, English poetry, the modern novel—these are great achievements, but scarcely comparable to the forward movement in science. The older sciences have been reformed and new departments have been established. But amid all this scientific progress nothing has been more notable—at least from my own partial point of view—than the development of psychology into a science rivaling in activity and fruitfulness the other great sciences.

J. McKEEN CATTELL.

COLUMBIA UNIVERSITY.

THE SENFF ZOOLOGICAL EXPEDITION TO  
THE NILE VALLEY.

THE chief object of the expedition was to procure the life-history of *Polypterus* and its bearings upon the problem of the relation of the Crossopterygian fishes to the Amphibia. In the last few years the former theory that Amphibia sprang from Dipnoan fishes has gradually given way to the present view that *Dipnoi* are to be regarded as parallel to Amphibia from a common Crossopterygian origin.

Several very successful expeditions have been recently sent out to procure material for the embryology of Dipnoans, notably that of Richard Semon from Jena and that of Graham Kerr from the University of Cambridge. The former secured the complete life history of *Ceratodus*, and the latter brought back the embryology and complete life history of *Lepidosiren*, a South American form. In the meanwhile nothing has been done upon the development of *Polypterus* because of the exceptional difficulties which stood in the way of procuring material. The fish is abundant in the unhealthy equatorial zone of Africa, being recorded on the West Coast rivers as well as in Central Africa. It is also found in the Nile, but the Upper Nile, where it probably occurs in greatest abundance, has not been open to

naturalists during the occupation by the Mahdi.

Upon learning of the importance of this investigation, Charles H. Seuff, Esq., of New York City, very generously contributed the greater part of the funds for the purpose, and the full equipment was made by the Zoological Department of Columbia University, with the assistance of Professor Osborn. Mr. N. R. Harrington, Fellow in Zoology, and Dr. Reid Hunt, Tutor in Physiology, volunteered to go to any part of Africa where it seemed most probable that embryonic stages could be secured. On reaching London they consulted with Dr. Boulenger and Professor Günther, also with Mr. Henry M. Stanley and Miss Mary H. Kingsley. The advice of these and many other naturalists and African explorers being strongly against the West Coast, it finally appeared best to choose the Nile Valley. The progress and results of the work may be extracted from Mr. Harrington's report.

H. F. O.

Leaving New York on April 23d, we spent two weeks in London, making inquiries about Old Calabar, the Congo, Senegambia and Egypt. The rains having been prevalent on the West Coast for a month, the presumption was that the fish had already spawned there. Further, information was gathered in London which led us to think that *Polypterus* spawned in Lake Menzaleh, a connection of the delta of the River Nile.

On May 26th we reached Cairo, where permission to fish, interpreter, assistant and outfit were obtained. We were received by the Under-Secretary of State, Clinton E. Dawkins, as guest of the Egyptian government, and given laboratories and apartments in the capacious Fisheries plant near Damietta. The sympathy of the Egyptian government with pure scientific work was demonstrated by the repeated favors shown us.

But after three weeks' search we found that *Polypterus* did not occur in Lake Menzaleh during the low Nile period, and starting for the nearest point on the river we searched along the banks of the Nile until we came upon several *Polypterus* near Ras-el-Ghelig. From this point we explored carefully for 377 miles, having as many as thirty fishermen at work at one time in promising regions. The result was that on June 22d we settled down at Mansourah, forty miles from the sea, where we anchored for the summer over what was then the best *Polypterus* fishing ground not closed on account of the Anglo-Egyptian campaign.

The fish came in slowly, but, as a result of this, there was abundant time to study, to carefully inject, and to make the long-wished-for observations on living material.

The Nile being especially late in coming down, we remained at Mansourah until August 18th, and in our two months' stay accumulated a large number of the fish, beside very interesting and valuable cytological material from *Mormyrus*, *Malapterurus* and other Nile forms. After the 18th of August, when the tremendous flooding makes fishing in the river impossible, we worked in the canals, and, although we obtained fish as late as August 30th, the eggs were still immature. We sailed from Port Said September 10th.

As to the material brought back, it includes some beautiful invertebrate collections made in the Red Sea, numerous Elasmobranchs, lizards and general collections from the eastern Mediterranean, an admirable collection of Nile fishes (on which the Napoleonic expedition has left little undone in a systematic way), a still larger collection of the salt and brackish water fishes of Lake Menzaleh, and a considerable amount of morphological, neurological and cytological material of great interest.

N. R. HARRINGTON.



FISHES NEW TO THE FAUNA OF SOUTHERN  
NEW ENGLAND RECENTLY COLLECTED  
AT WOODS HOLE.

DURING the past four years a rather large number of fishes, chiefly sub-tropical, have been collected by the U. S. Fish Commission at Woods Hole; some of these were not previously known on the Middle Atlantic and New England coasts, some had not before been detected in United States waters, one was new to the western Atlantic, and two were undescribed. Notwithstanding the continuous systematic collecting which has been carried on at this place for more than a quarter of a century, nearly every season yields unlooked-for additions, the present year being no exception. There are now known from the immediate vicinity of Woods Hole 222 species of salt-water and fresh-water fishes; this is a much larger number than has been reported from any other single locality in the United States except Key West, or, in fact, from any State north of Florida. Going back only to the all of 1894, the record of additions to the local fish fauna comprises 12 species belonging to 10 teleostean families; most of these are so interesting that they will be separately referred to, 5 being new to United States waters.

The mackerel family (*Scombridae*), which was already very generously represented at Woods Hole by 10 species, added another member in 1895, when a specimen of long-finned albacore (*Gerno alalunga*), 3 feet in length, was taken in the harbor. This pelagic fish is known from the Pacific, the eastern Atlantic and the Mediterranean, but has apparently not been met with elsewhere in the western Atlantic.

Three species of 'butterfly-fishes' (*Chaetodontidae*), a brilliantly colored family of the tropical seas, have been taken at Woods Hole. One of these, the 'parche' (*Chaetodon ocellatus*), is not rare, being observed here nearly every year and also occurring

in New Jersey and Rhode Island waters. The 'Portnguese butterfly' (*C. striatus*) is a straggler met with in 1894, one specimen being taken in October; it is not known elsewhere outside the West Indies. In 1897, in August and October, 6 examples of a strikingly beautiful new chaetodont (*C. bricei*) were obtained.

Five species of the typical sub-tropical family of snappers (*Lutianidae*) are now known from Woods Hole as stragglers, two being noticed for the first time in 1897. Besides the red snapper (*Neomænis aya*), the schoolmaster (*N. apodus*) and the mutton-fish (*N. analis*), there were taken last year in September young specimens of the gray or mangrove snapper (*N. griseus*) and the dog snapper (*N. joco*). The first of these has been recorded from New Jersey, but is not found in any abundance north of Florida; the second has not been previously reported north of the Florida Keys.

One of the most noteworthy captures was a small trigger-fish of the genus *Canthidermis*, taken in 1897; this is referable to Cope's *Balistes asperrimus* from the Isthmus of Panama, the type of which, in the Philadelphia Academy of Natural Sciences, has been compared with the Woods Hole specimen. No other examples are known, unless these prove to be the young of *Balistes sobaco* of Poey, from the West Indies.

In 1895 a porcupine-fish (*Diodon hystrix*) was taken in Buzzards Bay near the station. The only other specimens known to have been found north of Florida were taken on the shores of Maryland many years ago.

The family of marine gars (*Esocidae*) has three members on the New England coast, one of which (*Athlennes hians*) is represented by a large specimen taken at Woods Hole in 1895. This species normally ranges from the West Indies to Brazil, and is not elsewhere recorded north of Florida.

The 'permit,' or black-finned pompano (*Trachinotus goodeni*), described in 1896 from

the West Indies and southern Florida, was first taken at Woods Hole in 1894, and has since been found on several occasions. The species attains a weight of over 25 pounds, but only small specimens (3 inches or less) have up to this time been obtained here.

One species of half-beak (*Hyporhamphus roberti*) is common at Woods Hole, and in the current year another species (*Hemirhamphus brasiliensis*) was found for the first time. The latter is reported from Chesapeake Bay, but from no other localities north of Florida.

In August, 1898, there was taken a small file-fish of the genus *Alutera*, which resembles a fish known from Asiatic waters since pre-Linnæan times and described by Osbeck in 1757 as *Balistes monoceros*. It also has some points of similarity to the Cuban fish described and figured by Parra in 1787 under the vulgar name of 'lija barbuda,' which was subsequently identified by Poey and called by him *Alutera guntheriana*; the latter is regarded by some recent authorities as identical with *A. monoceros*, but the lack of specimens has prevented a settlement of the question. The Woods Hole fish differs in a number of important features from the foregoing, and apparently represents an undescribed species.

HUGH M. SMITH.

U. S. COMMISSION OF  
FISH AND FISHERIES.

#### NOTES ON INORGANIC CHEMISTRY.

UP to the present time there has been little experimental evidence of the trivalence of the so-called rare earths. They form no volatile compounds in which the density can be determined. The single proof of the correctness of the formulæ  $Ce_2O_3$ ,  $La_2O_3$ , etc., has been the determination of the specific heat of the metals by Hillebrand, which would give the atomic weights of the metals as about 140. This has been generally accepted by chemists, but from time to time

certain French chemists, notably Wyrrouboff, have questioned the trivalence. This has been largely on crystallographical grounds. Wyrrouboff shows that the silicotungstates of cerium, lanthanum and didymium are isomorphous with that of calcium, and argues from this that these metals must be bivalent. It is also stated that these metals in their compounds have certain strong resemblances to the alkaline earths. The whole subject is taken up by W. Muthmann, of Munich, in the *Berichte* and very fully discussed. He finds that many of these supposed resemblances do not exist in reality and that others do not substantiate the inference drawn from them. Particularly he shows that the fact that metals replace one another in isomorphous salts by no means proves them to have the same valence. By this argument a large share of the metals would be made bivalent. Especially in salts of high molecular weight, as in the salts of complex acids, the negative complex is the dominating influence in determining crystallographic form. This important principle is well sustained by Muthmann. To settle the matter of the valence of these metals beyond controversy, he has determined the valence, by the conductivity of solutions of lanthanum nitrate, sulfate and chlorid of different strengths, and the molecular weight of cerium chlorid by the boiling-point method. In every case a trivalent formula is obtained, and the correctness of the usually-given formulæ for compounds of these metals may be considered as finally established.

THE work of Professor Jörgensen, of Copenhagen, on the cobalt-ammonia bases is well known. It has continued over many years, following the work of Gibbs and Genth, which was published in the *Smithsonian Contributions to Knowledge* in 1856. In the last number of the *Zeitschrift für anorganische Chemie*, Jörgensen gives a most

valuable *résumé* of this work, collecting together, from his many articles, the best methods of preparing each compound of the class, and in many cases adding much hitherto unpublished information. The *résumé* will be of the greatest help to all future workers in this interesting field, for much as has been done by Dr. Gibbs, Professor Jörgensen and others, the ground can be said to be hardly more than broken.

A PRACTICALLY new field has been opened in the same number of the *Zeitschrift*, by Professor Sabanejeff, of Moscow, that of structural isomerism in inorganic compounds. While there seems to be no inherent reason why structural isomers, which are so familiar in organic chemistry, should not exist among inorganic compounds, no undoubted cases have hitherto been proved. The two isomeric sodium potassium sulfites  $\text{NaKSO}_3$  and thiosulfates  $\text{NaKS}_2\text{O}_3$  of Röhrig and of Schwicker are doubtful, and Hantzsch has shown that the two nitramins  $\text{NH}_2\text{NO}_2$  are rather stereoisomers than structural isomers; indeed, Hantzsch says that it seems probable that structural isomerism is perhaps confined to the compounds of carbon. Sabanejeff has attacked this problem with great success, and his first article deals with salts of ammonium, hydroxylamin and hydrazin. He describes seven pairs and one triplet of structural isomers, three of the fifteen compounds being new and nine never before analyzed. Among the pairs are hydroxylamin hypophosphite,  $\text{NH}_3\text{O}_2\text{H}_3\text{PO}_2$ , and acid ammonium phosphite,  $\text{NH}_3\text{H}_3\text{PO}_3$ ; hydrazin phosphite,  $\text{N}_2\text{H}_4\text{H}_3\text{PO}_3$ , and acid ammonium amidophosphate,  $\text{NH}_2\text{PO}(\text{OH})_2\text{NH}_3$ ; and the triplet, ammonium oxyamidosulfonate,  $\text{NH}(\text{OH})\text{SO}_2\text{H.NH}_3$ , hydroxylamin amidosulfonate  $\text{NH}_2\text{SO}_2\text{H.NH}_3\text{O}$ , and hydrazin sulfate,  $\text{N}_2\text{H}_4\text{H}_2\text{SO}_4$ . In all these cases the salts are well characterized and stable. This work is of great importance,

as it settles the fact that structural isomerism is a general property and not peculiar to the compounds of carbon.

J. L. H.

#### CURRENT NOTES ON ANTHROPOLOGY.

##### CRANIOLOGICAL OPINIONS.

THE subject of craniology in its relation to anthropology is taken up by Dr. R. Lehmann-Nitsche in an article in the *Revista del Museo de la Plata* (Tom. IX., 1898). After some preliminaries, he points out with distinctness the inability of a single physical peculiarity, such as the cranial index, to fix racial lines; and draws a comparison between the two theories most recently propounded, the one by Wilser and the other by Sergi, showing how they are in absolute contradiction.

His conclusion is that 'craniology, as at present studied, is incapable of defining typical or racial characteristics.' Much of this, he argues, is due to a confusion of biological and racial factors of development.

Dr. Marina, in his 'Studii Antropologici' (Torino, 1897), concludes with the affirmation: "The terms 'leptoprosopic' and 'chamæprosopic,' no more than those of 'dolichocephalic' and 'brachycephalic,' are competent for distinguishing the varieties and types of the human skull."

Some may remember that in a work published eight years ago I advanced precisely this opinion about craniology ('Races and Peoples,' pp. 19, 20).

##### ANCIENT GRAVES IN MAINE.

DR. CHARLES C. WILLOUGHBY, chief assistant in the Peabody Museum, in Vol. I., No. 6, of the 'Archæological Papers' published by the Museum, gives a careful account of his investigations of the prehistoric burial places along the coast of Maine. It is well illustrated, with four plates and fifty drawings in the text.

The graves differed in age. Beads of na-



tive copper were found in one, with fragments of bone. In others the bones had entirely disappeared. There was no pottery, but well-made, polished and clipped stone implements (as arrow-points, knives, celts, gouges and pendants) were abundant. Iron pyrites for 'firestones' and red ochre for paint were quite common.

Both Dr. Willoughby and Professor Putnam (who contributes a prefatory note) express a doubt that these were Algonquian graves. They suggest the Beothucs of Newfoundland as their possible constructors.

#### GEOGRAPHY AND ANTHROPOLOGY.

THIS autumn the Geographical Institute of Brussels, a branch of the 'Université Nouvelle,' begins its courses of instruction. It offers a three years' course in geography and expects to grant a diploma.

It is interesting to note the position assigned to anthropology in this course. In the first year it divides with biology one hour a week; in the second and third year it has one hour a week to itself, and in the third year ethnography has also an hour; these out of about fifteen instruction hours weekly. The professor of this course is not named in the preliminary announcement.

This is perhaps as much as can be expected at present; but it seems still remote from the definition of geography given by Dr. Hugh R. Mill some years ago—'the description of the earth in relation to man.'

D. G. BRINTON.

UNIVERSITY OF PENNSYLVANIA.

#### SCIENTIFIC NOTES AND NEWS.

##### A NATIONAL PHYSICAL LABORATORY FOR GREAT BRITAIN.

THE report of the committee appointed by the Treasury to consider the desirability of establishing a national physical laboratory was issued on October 4th. The Treasury minute appoint-

ing the committee was dated August 3, 1897, and was as follows:

To consider and report upon the desirability of establishing a national physical laboratory for the testing and verification of instruments for physical investigation; for the construction and preservation of standards of measurement, and for the systematic determination of physical constants and numerical data useful for scientific and industrial purposes; and to report whether the work of such an institution, if established, could be associated with any testing or standardizing work already performed wholly or partly at the public cost.

The committee consisted of Lord Rayleigh (chairman), Sir Courtenay Boyle, Sir Andrew Noble, Sir John Wolfe Barry and Messrs. W. C. Roberts-Austen, Robert Chalmers, A. W. Rücker, Alexander Siemens and T. E. Thorpe.

The committee review the existing institutions in Great Britain and state:

After consideration of the evidence the committee have come to the conclusion that an institution should be established for standardizing and verifying instruments, for testing materials, and for the determination of physical constants. Work useful both to science and industry could therein be performed for which no adequate provision is at present made, either in this country or at the Bureau International des Poids et Mesures. Such work could not, or, at all events, in all probability would not, be undertaken by individual workers or by institutions primarily devoted to education. In the opinion of the committee the proposed institution should be established at the national expense on lines similar to, though not at present on the scale of, the Physikalisch-technische Reichsanstalt.

The conclusions of the committee are as follows:

1. That a public institution should be founded for standardizing and verifying instruments, for testing materials, and for the determination of physical constants.

2. That the institution should be established by extending the Kew Observatory in the Old Deer Park, Richmond, and that the scheme should include the improvement of the existing buildings, and the erection of new buildings at some distance from the present observatory.

3. That the Royal Society should be invited to control the proposed institution, and to nominate a governing body, on which commercial interests should be represented, the choice of the members of such body not being confined to Fellows of the Society.

4. That the Permanent Secretary of the Board of Trade should be an *ex-officio* member of the governing body; and that such body should be consulted by the Standards Office and the Electrical Standardizing Department of the Board of Trade upon difficult questions that may arise from time to time or as to proposed modifications or developments.

#### THE FRANKLIN INSTITUTE.

THE Franklin Institute, Philadelphia, founded in 1824, makes an appeal for an increased endowment. The present endowment is small, and although the membership of nearly 2,000 contributes an annual addition to the income, this is not sufficient to carry on the work. The membership is largely composed of artisans, and the dues (\$8 per year) are properly low, so that the benefits of the Institute may reach as many as possible. A fund of \$350,000 is needed, of which it is hoped that at least \$100,000 may be provided by the present effort.

The Franklin Institute is able to point to the following record of achievements in behalf of science and its applications:

The Institute held its first exhibition of American manufacturers in October, 1824, and subsequently twenty-eight exhibitions. It instituted the movement that culminated in the Centennial Exhibition of 1876. Its International Electrical Exhibition in 1884 contributed the impulse which has resulted in bringing the United States to the leading position in the utilization of electricity. It founded the School of Design for Women. It established the first high school in Philadelphia. It established a uniform system of machine screw threads. It made tests of the strength of materials for the United States government. It investigated the causes of the explosions of steam boilers, at the request of the Treasury Department. It was the pioneer in making and recording systematically meteorological observations, culminating in the establishment of the Weather Bureau. The publication in its journal of abstracts of specifications and claims of United States patents, from 1826 to 1843, now affords the only available reference to this information, the government having failed to publish them prior to 1843. It aided in founding the Pennsylvania Museum and School of Industrial Art, by lending a helping hand and sheltering roof

in its infancy. It investigated the various forms of water wheels for giving economical value to water power. The law of Pennsylvania relating to our system of weights and measures was enacted as the result of the report made by the Institute at the request of the Legislature of the State. In response to a request of City Councils, it nominated an expert commission to report on a future water supply for Philadelphia. In response to a request by the Board of Health, it has recently investigated and reported upon the subject of the abatement of the 'Smoke Nuisance' in Philadelphia. Its journal, published continuously since 1826, now in its 146th volume, constitutes an invaluable record of the arts and manufactures, especially as developed in the United States. The Institute keeps constantly in touch with science as applied to the useful arts, by its lectures and the papers read at its meetings, and those of its Chemical, Electrical and Mining and Metallurgical Sections. Its drawing school, established in 1824, devoted to mechanical and architectural drawing, has been maintained uninterruptedly for seventy-five years. Its library is one of the most complete scientific and technical libraries in the world and is open to the public for reference from 10 a. m. to 3 p. m., to members from 9 a. m. to 10 p. m.

#### GENERAL.

M. HENRI MOISSAN, Sir William Crookes and Professor J. H. Van't Hoff have been elected honorary members of the American Chemical Society.

THE Harveian Oration before the Royal College of Physicians of London, by Sir Dyce Duckworth, was delivered on October 18th. The Bradshaw Lecture will be delivered by Dr. W. M. Ord on Thursday, November 10th, his subject being 'Myxœdema and allied Conditions.' The Goulstonian Lectures will be given next year by Dr. G. R. Murray, of Newcastle, who has taken for his subject the 'Pathology of the Thyroid Gland.' The Lumleian Lectures for next year will be given by Dr. Samuel Gee. The Croonian Lecturer for 1899 is Professor Bradbury, of Cambridge, and for 1900 Dr. F. W. Mott, F. R. S.

PROFESSOR VOLNEY M. SPALDING (botany),\*

Professor Alexander Ziwet (mathematics), Professor George W. Patterson (physics) and Professor Dean C. Worcester (zoology), of the University of Michigan, have been granted leave of absence for the present academic year.

PROFESSOR E. B. WILSON, of Columbia University, has recovered from the serious illness from which he suffered during the summer, but will take advantage of the Sabbatical year allowed by Columbia University to spend next year in travel and research abroad.

DR. F. MORLEY has resumed the chair of mathematics in Haverford College after a year's leave of absence. While abroad he was given the D. Sc. by Cambridge University.

PROFESSOR ISRAEL C. RUSSELL, of the department of geology of the University of Michigan, spent the three months' summer vacation conducting a geological survey for the United States government over the northern portion of the Cascade Mountains. The greater part of the work was in Washington State and extended from the Northern Pacific Railroad to the Canadian boundary, crossing the mountains several times. Among the places of interest visited was Glacier Peak, the height of which was verified.

PROFESSOR JAMES A. CRAIG, of the University of Michigan, spent the summer vacation in London at work in the British Museum, on the astrological-astronomical tablets of the Kujundjik (Nineveh) collection known as the Illumination of Bêl. This is the most important series of unedited texts in the British Museum and by far the most important in many respects to be found in any of the collections extant. Professor Craig has now completed all the texts of the series, which numbers about 130 tablets. His manuscript is already in the press with Die Hinrichs'sche Buchhandlung, Leipzig.

DR. W. P. WILSON, Director of the Philadelphia Commercial Museums, has arranged to give a course of lectures at the Museums on commercial geography before the Philadelphia Normal and High School students.

THE United States Civil Service Commission announces that on October 25, 1898, examination will be held for the position of assistant,

editing, abstracting, proof-reading and indexing, in the Department of Agriculture, at a salary of \$1,200 per annum. The scope of this examination may be found in Section 67 of the Manual supplied by the Commission.

THE fifth annual exhibition of the department of entomology of the Brooklyn Institute was opened on October 8th at the museum building, and will continue through the month. It includes rare specimens of moths and butterflies, filling some forty-eight cases, most of which are loaned from the collection of the late Mr. Berthold Neumögen. This collection, containing nearly 120,000 specimens made at a cost of \$75,000, is deposited in the Brooklyn Museum.

THERE is a serious epidemic of yellow fever in Louisiana and Mississippi, more than 1,000 cases having occurred. The usual panic accompanying epidemics of yellow fever in the South has followed, and it appears that the patients are not properly cared for. Still the mortality is low, only 69 deaths having been reported.

AT the Boston meeting of the American Chemical Society the Secretary reported the membership to be 1,318, an increase of 162 since its annual meeting in December last. Professor Edgar F. Smith was elected a member of the Committee on Papers and Publication, and a committee was appointed to consider an increase in the membership of this Committee, so that it shall include special representatives of each of the important departments of chemistry. It was decided to remove the library to Havemeyer Hall, Columbia University, and Mr. M. T. Bogert was elected Librarian.

THE American Ornithologists' Union will hold its sixteenth annual meeting at Washington, D. C., beginning on November 14th. Titles of papers should be forwarded to the Secretary, Mr. John H. Sage, Portland, Conn., not later than November 6th.

A CONVENTION of Weather Bureau officials was held at Omaha on October 12th and 13th. A number of interesting papers were presented, including one on the 'West Indian Hurricane Service,' by Professor Willis L. Moore, Chief of the U. S. Weather Bureau.



THE second Huxley lecture given by Professor Rudolf Virchow at the opening of the Charing Cross Hospital, on October 3d, entitled 'Recent Advances in Science and their bearing on Medicine and Surgery,' was of great interest both to men of science and physicians. If space permit it will be republished later in this JOURNAL. Professor Virchow was given a complimentary dinner on October 5th, the chair being occupied by Lord Lister. Speeches were made by Lord Lister and Professor Virchow, as also by Sir W. Broadbent, Surgeon-General Jameson, Sir Samuel Wilkes, Sir William MacCormack, Professor Chiene and Sir William Turner. Professor Virchow was expecting to be present at the ceremonies in connection with the opening of the Thompson-Yates Laboratory at Liverpool on October 8th.

THE following details regarding the life of Professor Virchow, taken from *The British Medical Journal*, may be of interest: Rudolph Ludwig Karl Virchow, to give him his full complement of names, was born on October 13, 1821, at Schivelbein, a small town in Farther Pomerania. He received his early education in the gymnasium of Cöslin, where he was thoroughly grounded in the Latin and Greek languages, and where also he learnt Hebrew so well that he took it up as a voluntary subject at his *Abiturientenzamen*, which he passed in 1839. In the same year he entered the Friedrich Wilhelm Institute, for the training of army surgeons, in Berlin. At this medico-military academy—from which have come at different times many men of the highest distinction, such as Nothnagel, Leyden, Hueppe, Loeffler, Gaertner, Schmidt-Rimpler, Fraentzel and others—Virchow had Hermann von Helmholtz among his fellow students. Among his teachers were Johannes Müller, Schoenlein, Dieffenbach and Casper. The teacher who most influenced him was Müller, who, in Virchow's own words, 'founded no school in the sense of dogmas, for he taught none, but only in the sense of method.' Virchow took his Doctor's degree in 1843, his inaugural thesis bearing the title 'De Rheumate præsertim Cornæ.' Soon after graduation he was appointed Prosector in the Charité Hospital where he laid the foundations of his future fame

as a pathologist. In 1848 his name first began *voltare per ora* in consequence of his being sent to investigate a severe epidemic of typhus in Upper Silesia. The report which Virchow presented on that occasion was not only a masterpiece of scientific investigation, but marked him out as a man of the most enlightened philanthropy. What he saw in the course of that inquiry converted him to Radicalism, a political creed which he has ever since professed. He insisted strongly on the necessity of social as well as sanitary reform for the prevention of evils such as came under his notice in Silesia. On his returning to Berlin, while continuing to add new truths to the new science of pathology which he was creating, he was very active as a reformer of society in general and of his own profession in particular. In conjunction with a kindred spirit he founded a journal entitled *Die medicinische Reform*, in which the wrongs and grievances of the profession in Germany were discussed in a remarkably outspoken manner. This periodical ceased to exist on Dr. Virchow being called to occupy the chair of pathology in the University of Würzburg, in 1849. At Würzburg he remained seven years, his fame meanwhile spreading over the whole world, so that when a vacancy in the corresponding chair at Berlin occurred, in 1856, he was appointed to it in the teeth of strong political opposition. It would be out of place here to attempt to give even a summary of his scientific achievements. It is sufficient to recall that his great work, 'Die Cellularpathologie in ihrer Begründung auf physiologische und pathologische Gewebelehre,' began to appear in 1858. In that work the far-reaching doctrine *Omnis cellula a cellula* was enunciated, and from this 'cell' has come the long and splendid series of its author's later contributions to knowledge. In 1858 appeared Virchow's other great work, 'Die krankhaften Geschwülste.' Reference should also be made to his famous *Archiv*, which a year or two ago celebrated the jubilee of its foundation, and which still stands in the front rank of publications devoted entirely to scientific medicine. A list of his writings would occupy several pages of this JOURNAL. Among Virchow's great works may be counted his famous museum, which, when

he first became professor in Berlin, numbered only some 1,500 specimens. But Virchow is not merely the greatest of living pathologists; he has for half a century been equally prominent in his own country as a politician. He has for many years been the leader of the Opposition in the German Reichsrath, and between thirty and forty years ago he had the honor of being challenged by Prince Bismarck. It is much to Virchow's honor that he had the courage to decline to risk a life so valuable for science and humanity in a foolish duel. Even pathology and politics do not exhaust the intellectual activities of this many-sided man. He is President of the German Geographical Society, in the work of which he takes the keenest interest. He is also justly famous as an anthropologist and archaeologist. It may be added that in his writings he shows a feeling for literary form rare in medical authors, and especially rare in German professors. His lucidity of style and the logical order in which he unfolds his thoughts make his works a pleasure to read.

DR. WOODWARD, Health Officer of the District of Columbia, has submitted to the Commissioners his estimates for appropriation, the sum being placed at \$160,540. The estimates include \$5,000 for the establishment and maintenance of a bacteriological laboratory.

GOOD work is being done by the Paris municipal bacteriological laboratory, says the *New York Medical Record*. This laboratory for the diagnosis of contagious affections was created by the Municipal Council in 1895, and is open to the public every day in the year from eight o'clock in the morning until eight in the evening, including Sundays and holidays; moreover, the necessary articles are given to doctors who ask for them for the bacteriological diagnosis of diphtheria, tuberculosis and contagious affections of which the germs are known. The results of the analyses are sent directly to the doctors, at longest twenty-four hours after reception of the pathogenic products at the laboratory. These results can be sent by telegraph if desired and at the expense of the doctor, but the examination and diagnosis are absolutely gratis. The laboratory received in August, 1898, forty-eight products suspected to

be tuberculous, in which the bacillus of Koch was discovered sixteen times.

#### UNIVERSITY AND EDUCATIONAL NEWS.

THE Board of Education of New York City has presented to the Board of Estimate and Apportionment a request for over \$12,000,000 for current expenses and about \$10,000,000 for new buildings for the year 1899. The estimates for current expenses are \$3,000,000 more than the appropriation for the present year, the additional sum being intended chiefly for the increase of salaries.

THE will of the late John D. W. Joy, of Boston, gives \$30,000 to Tufts College, the bequest to take effect on the death of his widow.

A NEW class of honorary fellowships has been created this year at Cornell University. Those holding the Ph.D. degree from any institution may obtain these fellowships, which carry no emolument, but allow free tuition, the use of the library, etc.

DR. SIMON FLEXNER, associate professor of pathology at the Johns Hopkins University, has been appointed professor of pathological anatomy.

THE following promotions and new appointments have been made at the Massachusetts Institute of Technology: Henry P. Talbot, to be professor of analytical chemistry; H. O. Hoffman, professor of mining and metallurgy; D. P. Bartlett, associate professor of mathematics; R. R. Lawrence, instructor in physics; and as assistants: J. C. Coffin, H. W. Smith and M. D. Thompson, in physics; and G. M. Holman, in biology.

THE following instructors have been appointed in the University of Michigan: Lawrence Bigelow, in chemistry; James Pollock, Hamilton Timberlake and Julia W. Snow, in botany; Augustus Trowbridge, in physics; W. H. Butts and A. W. Whiting, in mathematics, and Archibald Campbell, in organic chemistry.

DR. MARTIN B. STUBBS, of Haverford College and Johns Hopkins University, has been appointed assistant in chemistry and physics in Haverford College.

THE British Education Department has issued

the reports which have been received this year from the twelve colleges which participated during the year ended March 31st in the annual grant, now amounting to £25,000, made by Parliament for 'University Colleges in Great Britain,' and the three colleges in Wales, which receive from the Treasury a grant of £4,000 each. The twelve colleges are: Birmingham, Mason College; Bristol, University College; Dundee, University College; Leeds, Yorkshire College; Liverpool, University College; London, Bedford College, King's College, University College; Manchester, Owens College; Newcastle-upon-Tyne, Durham Science College; Nottingham, University College, and Sheffield, University College. The Welsh Colleges are: Aberystwyth, University College of Wales; Bangor, University College of North Wales; Cardiff, University College of South Wales and Monmouthshire. Major P. G. Craigie's annual report to the Board of Agriculture on the distribution of grants for agricultural education and research in 1897-98 has also been issued as a Parliamentary paper. The total amount distributed during the financial year to the fifteen institutions receiving assistance was £7,200, as compared with £7,000 in the previous year.

#### DISCUSSION AND CORRESPONDENCE.

##### TROCHOSPHERA AGAIN.

IN SCIENCE of December 25, 1896, Dr. Kofoid, of the Illinois Fresh-water Biological Station, records the occurrence, during the preceding summer, of *Trochosphaera solstitialis* Thorpe in the Illinois River. The discovery in America of this remarkable Rotifer, previously known only from the antipodes, is of great interest. Dr. Kofoid raises the question whether its presence in Illinois is due to recent importation, or whether *Trochosphaera* is to be considered a normal member of our fauna, taking a place with many other Rotifera as a cosmopolitan form. Its rediscovery at a station distant from that recorded by Kofoid is perhaps worthy of mention in the columns of SCIENCE. *Trochosphaera solstitialis* was found in the work of the Biological Survey carried on during the past summer at Put-in-Bay Id., Lake Erie, by the U. S. Fish Commission. It occurred very

sparingly in a swamp near the U. S. Fish Hatchery, Put-in-Bay, for a few days in August, 1898. This swamp has a dense bottom growth of *Ceratophyllum*, while the surface is completely mantled with *Lemna*, *Spirodela* and *Wolffia*. It is connected with Lake Erie by a streamlet about forty feet in length, the direction of the current through which depends upon the level of the lake. When the lake is high, water flows into the swamp, and at such times the ordinary plankton Rotifera of the lake are found in the swamp. When the lake is low the swamp water passes outward into the lake. *Trochosphaera* was found at a low-water period, along with *Notops clavulatus* and some other Rotifers which, though rare, are known to be widely distributed. As this swamp has such intimate connection with the lake, it would not be surprising to find *Trochosphaera* in swampy parts of Lake Erie itself.

The discovery of *Trochosphaera* at two such widely separated stations in the United States certainly tends, so far as it goes, to indicate that the animal is to be considered a normal member of the American fauna. Workers on Rotatoria are few in America, and it may be that more extended observations would show *Trochosphaera* to be widely distributed, even though somewhat rare.

Unfortunately, but few individuals were obtained, so that it is not possible to furnish specimens to those desirous of examining this remarkable animal.

H. S. JENNINGS.

DARTMOUTH COLLEGE, HANOVER, N. H.

##### THE OCCURRENCE IN GREAT ABUNDANCE OF INSECTS ORDINARILY MERELY COMMON.

A NOTE in one of the New York papers a day or so ago reporting that a strange butterfly—in all probability *Anosia plexippus*, judging from the description of the color—was present in extraordinary abundance at Topeka, Kansas, on the 6th inst., preventing work out of doors and gathering on the rails of a branch of the Union Pacific Railroad in such numbers as to stop a train by their bodies greasing the rails, calls to mind a similar large swarm of this species seen by the author near Unadilla, Nebraska, in 1885. The air was full of the in-



sects, which were flying lazily southward, paying no attention to the flowers in their way. They were not quite as numerous, however, as the Topeka report makes them out to have been. Large swarms of this species are not infrequent, being noticed from time to time.

The report also calls to mind two other instances that come under this head. One is a report of a large number of centipedes seen in Nebraska all crawling southward (?) and noted by the author in SCIENCE some years ago. The other was the occurrence at Lincoln, Nebraska, in 1889 or 1890, of a great swarm of *Hydrophilus* (probably *triangularis*) attracted apparently by the electric lights. They were so numerous that the sound produced by their striking the electric cars resembled the rattle of large hail stones. They came in at the open windows of the cars, greatly annoying the passengers. Along the sidewalk of O Street their mashed bodies were very numerous. Possibly a bushel or more could have been swept up in the distance of a block. The occurrence of the insect in such large numbers is the more remarkable since in the vicinity of Lincoln it had not formerly been noted as a very common species, ponds and other suitable breeding places not being abundant. Yet the fact that the electric light appeared to form a factor in the concentrated abundance of the insect seems to indicate that the gathering was probably from the country round about, though it does not preclude the possibility of a migrating swarm, due possibly to the drying-up of their natural habitats.

F. C. KENYON.

WASHINGTON, D. C., October 8, 1898.

#### SCIENTIFIC LITERATURE.

##### SOME RECENT LITERATURE ON CHILD-STUDY.

THERE are probably few terms in popular use which are more variously understood than Child-Study. In the minds of some it revives a harrowing scene wherein parents and teachers are observed plying trivial or abstruse questions to their children, or experimenting with them in other ways, in the endeavor to obtain data requested in syllabi and blanks which are being scattered broadcast over the land, having already, as one eminent person is afraid, found

their way into most homes and school-rooms of the country. When these data are obtained they are hurried off to the designers of the syllabi, who tabulate them, presenting the outcome in numerical results which are supposed to constitute the propositions of a presumptive science of Child-Study. To other minds this term denotes a significant movement which has for its purpose the investigation of psychical phenomena occurring in the development of human beings, this work being conceived of as different from the analysis and description of adult consciousness. Those who regard Child-Study from this point of view see that while some of the investigations that are being made, possibly the majority of them, are valueless from a scientific standpoint, yet the heart of the thing is full of vitality and is well able to produce increasing abundance of life in the whole structure.

To those who have 'syllabi' and 'Child-Study' so strongly associated that they cannot be dis severed, this movement will be looked upon as a fad of only temporary interest and of little or no importance. Professor Baldwin, for instance, seems to estimate Child-Study in this way;\* for he certainly cannot have in mind the broader reaches of the subject as concerned with the study of human ontogeny, since he would scarcely regard his own numerous contributions thereto, nor would anyone else, as of a faddish, transitory character. It seems likely that others have connected the term simply with the least important aspects, with the froth or eddyings, one might say, of the study of developmental psychology. Doubtless its origin and use has led to this confusion, since it has been employed principally by those who have suddenly become infatuated with the study of children, but who have brought to the undertaking meager attainments, and scarcely any first-rate qualifications for rightly conducting the work. In this way much is being offered as contributions to science which in its elaboration has not conformed to the rules of scientific procedure. But to some investigators at least this is not an occasion for discouragement, but rather one for rejoicing and congratulation, since all science has been conceived and nour-

\* See *Psychological Review*, March, '98, p. 219.

ished in its infancy in this apparently unscientific manner. When there is vast enthusiasm in new phenomena on the part of the populace large amounts of data regarding them may be obtained where otherwise it would be extremely difficult to secure them; and while there is danger of error creeping into the conclusions as a result of materials being amassed whose antecedents and accompaniments have not been properly ascertained in the recording, still this error cannot long abide the scrutiny of scientific and practical people, and it must consequently be at best short-lived.

One of the peculiarities and at the same time one of the chief difficulties characteristic of this subject of Child-Study is the diversified methods which are being pursued in obtaining data. Mr. Sully, in his *Children's Ways*,\* has made use of a mode of studying children which will doubtless become increasingly popular. He evidently carries about him a note-book into which go many things that he hears and sees when he is in the company of childhood. Then at his leisure he classifies what he has noted, and gives the result to the reader without making any serious effort at explanation or interpretation. His purpose in this book seems to be simply to draw the attention of people to phenomena in child life which, while oppressively common one might almost say, are yet very little heeded by the average parent or teacher; for the reason, doubtless, that the things with which we are constantly in contact are apt to acquire an indifferent interest for us. We accept them as matters of course, and are then rendered incapable of seeing the great truths embodied in them. This in itself justifies such a hook as Mr. Sully's—that it incites thought regarding some of the most frequent exhibitions of child-life.

The 'Ways of Children' is adapted principally for popular reading, and Mr. Sully probably had no intention of contributing very extensively to the science of human development by the things which he has written therein. And yet the scientist will find here data well classified which will be of value in elabo-

\*Sully: *Children's Ways, Being Selections from the Author's 'Studies of Childhood,'* with some Additional Matter. D. Appleton & Co., N. Y.

rating certain principles of ontogenesis. The materials have the exceptional quality of being for the most part rudely concrete; they are the verbatim utterances of real children and vivid descriptions of their doings. One may get some idea of the range of the author's observations by glancing over the titles of his chapters: *The Realm of Fancy; The Enchantment of Play; Attacking our Language; The Serious Searcher; First Thoughts: (a) The Natural World, (b) Self and other Mysteries; The Battle with Fears: Good and Bad in the Making; Rebel and Subject; At the Gate of the Temple; First Pencillings.*

Some may, upon reading this book, feel that it deals, after all, with quite trivial affairs. For one thing, Mr. Sully does not produce tables and curves, the summaries of studies upon multitudes of children; and many in these days seem to think that the study of two or three individuals is of no great account for either practice or theory. We must have experiments by the thousands and laws in percentages. But it is interesting to speculate upon the value to science of discovering that nine hundred and seventy-five children perform in a certain way, while nine hundred and fifty of the same age and under the same conditions act differently. In the face of results like these the experimenter concludes that rather more act in a given way than otherwise; but when this conclusion is to be made the basis for a principle or system of training its work is exceedingly doubtful, to say the least. Is it not of greater value to have the product of careful daily observations upon a few children than to be continually working with such large figures? Have we not in child-study fallen victims to the general tendency to overestimate the importance of magnitude—of great numbers and large sizes?

When Mr. Sully attempts to assign motives for the activities he sees in children he is apt to raise doubts in one's mind, as perhaps might be expected. For instance, witness what he gives as his opinion respecting the reason why children love to play at rolling hoop\*: "Is not the interest here due to the circumstance that the child controls a thing which in the

\* Page 24.

freedom of its movements suggests that it has a will of its own? This seems borne out by the following story: A little girl of five once stopped trundling her hoop and said to her mother she thought that her hoop must be alive, because 'it is so sensible; it goes where I want it to.' Perhaps the same may be said of other toys, as the kite and the sailing boat." To the writer it seems that the interest lies mainly in the great wealth of motor adjustments which this game occasions, together with the delight of accomplishing a difficult task; and if the child has any conception of will in the object it at least never rises up into explicit consciousness, even though he employ such terms as 'sensible' in describing its activities. This difference of opinion emphasizes the necessity of employing more exact methods in discovering the motive of much of the evolving mental life of the child.

All students of child-development would feel grateful to Mr. Sully if he had endeavored to find some unifying principle governing the behavior of the child mind at different stages in its progress toward maturity. It may be that there is no such unity of cause underlying the psychical activities of children, but if there is we are sorely in need of it to furnish a guide for the elaboration of an educational scheme. Our gravest affliction now seems to be that our teaching is based upon the doctrine that there is great and essential diversity in mental action, and this leads us in teaching to feel that we must have manifold methods required by the different operations of the mind and various branches of study to train different faculties. It appears very likely that there is more homogeneity in the mental activities of the child than we have been wont to think, and it would be of incalculable benefit to all who train children if they could see the underlying principles of psychical ontogenesis. It would save them from that distraction which seems everywhere apparent in those who have been studying psychology in the old way and learning about the manifold operations which seem to be more or less unrelated to one another. Mr. Sully's book leaves one with the feeling of disperseness; one is a little confused by the heterogeneity of things—the want of any unity of principle.

And this feeling lends emphasis to a question which of itself would keep popping into the mind of the reader. Are the peculiar sayings and performances of children set down in the book due to minds little stocked with knowledge reacting upon a complex environment, or are the children living over again in some measure the ancestral record? The author does not attempt an answer; and possibly it is well that he does not here, for he might fail of his purpose of enlisting the interest of the lay reader. But it is hoped that he will address himself some time to these problems, for his psychological training should make his discussion of them of value to all students of the evolution of mind in the individual.

Mr. Taylor, in his *The Study of the Child*,\* has produced a very different sort of book from Mr. Sully's. It is evident that he had a different purpose in mind—namely, to instruct young people regarding the proper methods of dealing with children as indicated by the results of modern scientific research. He has an eminently practical aim in view, and in estimating the worth of his work this must be kept constantly in mind. The scientific student would be apt to complain considerably of the method pursued unless he held before himself all the time its purpose, which is not to advance a science but to apply it in the most concrete way possible. It seems from the tone of the writing that the contents of the book were originally given as lectures to Mr. Taylor's students in the Normal School at Emporia, Kansas, and one is impressed that they must have been of interest and value to these teachers who have probably come to this subject with little previous acquaintance, and who have immediate practical problems in the school-room to solve.

In the main Mr. Taylor writes clearly and intelligibly for the readers he has in mind, which is not a simple task by any means; and he makes his discussion concrete by producing an abundance of apt illustrations which have fallen within his own experience. But the writer wonders why he felt it necessary to cling so closely to the terminology and methods of classification of the older psychology. He

\*Taylor: *The Study of the Child.* New York, D. Appleton & Co.



starts off discussing the various senses, then consciousness and apperception, then attention, followed by symbolism, language, muscular or motor control, feelings, will and its functions, perception, memory, imagination, conception, judgment, reasoning, etc. The disquisition upon the senses is principally hygienic, with some consideration of the effects upon the mind of their imperfect functioning, and the importance and method of training them. One feels in this part of the book that Mr. Taylor has the child always in mind, but when he reads the chapters upon the intellect and will he is distressed to find the treatment following almost precisely the methods of adult analytic psychology. Why are these things not viewed in the light of their development, their evolution, their genesis, showing how all the various operations, if they are really different, have come to be so in the child's mind? Perhaps the author felt that for young teachers he has proceeded in the most practical way to discuss the mental operations. But if he does, the writer must certainly differ with him; for it seems that it would be of far greater value, considered alike from the point of view of clearness of appreciation and concreteness to teachers of any age or degree of experience, to see how the intellect grows in a child than to examine what it is when full formed, except as the latter aids and complements the former. A teacher has to foster and direct mind growth, and she is not concerned at all with the fully grown thing, only as it enables her to comprehend the nature of the evolving entity more truly and completely.

When one keeps in mind the purpose of the book he can understand why reference has not been made more extensively to acknowledged authorities, and, also, why the style is so largely hortatory, even possibly dogmatic. It is addressed to persons who are not interested primarily in scientific method and accuracy, but who readily accept doctrines upon authority and who need to be exhorted to observe them in their own conduct. A criticism, though, should here be offered, which is applicable to much of modern writing upon Child-Study and allied subjects; propositions are oftentimes of too universal and sweeping a character when the

author cannot possibly have observed their applications in but a few instances. As an illustration of this tendency we may quote a passage which, by the way, discusses a very important matter: "Many a babe's mouth is sorely blistered by a hot gargle that the nurse, accustomed to drink boiling-hot tea three times a day, declares to be 'just warm, now dearie.' *Hot plasters and poultices are clapped on the little innocents without intelligence or mercy for the same reasons, and incalculable injury is thus done to a multitude of children.*" (The italics are added.)

Any book dealing with the practical applications of science is much more liable to arouse misgivings here and there than one which simply presents the results of scientific experiment. To fit a principle to concrete conditions is a task of more serious mien than to simply work out the principle, for in the first instance many more factors have to be thought of together and adjusted to one another. Mr. Taylor's book is to be warmly commended as illustrating and promoting a movement in the training of teachers in the normal schools which promises to be most fruitful in the near future. It is to be hoped that he will find time to give us a book on the *growth* of mind in school children, bringing to the work the results of modern experimental science, as he has done in the present volume in the treatment of the senses and other important subjects.

It seems to the writer that one of the most profitable lines of investigation, alike for a science of developmental psychology and for education, runs out in the direction of psychobiology; or, perhaps more definitely, psychophysiology. It will doubtless be generally appreciated that we must derive from physiological studies the hygienic conditions in conformity to which educational processes must occur. It seems, too, as if we were already able to say that the development of the brain and mental ontogenesis are closely correlated; and if this be true it should, in a very important way, contribute to a determination of the materials and methods of instruction at various stages in the child's education. The data regarding these matters can be supplied perhaps better by physicians than by any one

else; and *The Development of the Child*\* by Dr. Oppenheim will be gladly welcomed not alone for its own worth, but also as practically initiating a movement which should rapidly increase in breadth and momentum. Dr. Oppenheim is evidently a physician who has given attention not only to matters physical, but in an important manner to things spiritual. His practice being largely in a children's hospital, he has had unusual opportunities for making observations upon the topics which he discusses in his book. His chapter upon Facts in the Comparative Development of the Child is exceedingly valuable, since it strongly emphasizes a thought which is slowly getting established in people's minds—that the child is in many essential particulars different from the adult, and that growth consists, in a measure at any rate, in a series of transformations or metamorphoses which if completed finally culminate in a fully formed man or woman. While the author has comparatively little to say respecting changes which are known to occur in brain growth, yet it is reasonable to infer that this organ, like the others of the body, is subject to metamorphic processes in its progress toward maturity. This chapter illustrates a sort of investigation which it is hoped will receive the attention of scientists more fully in the future—the sequence in the ontogeny of the brain. It is encouraging to observe that physiologists like Wesley Mills are realizing the importance of such researches and are already making some valuable contributions thereto.

The chapter upon the Comparative Importance of Heredity and Environment is especially valuable alike for science and for education. The key-note of the chapter seems to be that the particular line of mental development occurring in the individual is determined more largely by the factor of environment than by anything else. The child, doubtless, brings into life a predisposition in certain directions due to heredity, but unless the elements in the environment favor the nutrition of special embryonic powers these will soon atrophy. Heredity of mental attributes is not so absolute and universal a thing as we have been thinking, says the author; and

\*Oppenheim: *The Development of the Child*. New York, D. Appleton & Co.

the reader, even though he has formed an opinion beforehand, will, when he completes the chapter, be inclined to agree to the proposition, in a measure at least. Abundant facts are adduced to show that adequate nutrition is the great determining principle in the development alike of body and brain. The importance of this for education can scarcely be overestimated. Aside from its value for mental hygiene it shows that that element in personality which receives the best nourishment from the environment will be apt to become predominant—an important principle in determining educational values.

But when the reader reaches the discussion of *The Place of the Primary School in the Development of the Child* he should be prepared for a very pessimistic view of the present situation in the world. It is really oppressive to find that practically everything that is is wrong. The primary school as it exists has nothing to commend it; it violates nearly all, if not all, the principles of normal growth in childhood, because it curtails freedom, spontaneity, and enforces concentration and co-ordination of bodily and mental powers before nature is ready for such things. One certainly cannot but endorse most heartily the contention of the author for greater freedom to be granted the child in all his school work. But it is hard to believe that everything we have been doing is bad. It is evident that Dr. Oppenheim has not in this chapter written with the same scientific care and caution that he has elsewhere. If he is right, as he will be interpreted by those who read him, the only recourse is in a return to nature wherein the order, the system, the method of education which has grown up in the development of the race will be obliterated, and we shall be back again to an orderless and systemless condition, a kind of neo-Rousseauism. But has not order and method in education been evolved as an essential element of progress in the race? And while undoubtedly formalism has been over-emphasized, yet is there not as great danger in lapsing back too far in the other direction?

The same criticism may be made of Dr. Oppenheim's writing here that has been made elsewhere in this article—the hyperbole seems to be too much in evidence. An extract will

illustrate: "The ordinary exercises in drawing are, beyond doubt, *useless and harmful*. In its best aspect it is *merely muscle-exercise*, but even as such it is, partly from its cramped and spasmodic position and movements, decidedly deficient. In almost all cases it is the *crudest sort of caricature* that represents and portrays nothing. It leads to no good, and it develops no ability, but, on the contrary, *elevates wrong and vicious presentments* into undue prominence. When it is 'directed' it is, if anything, worse; for then it receives the badge of authoritative affirmation. Unless it is the 'graphic record of a perceived fact' it is *worse than valueless*." (The writer has italicised.)

It is certainly a most excellent and needful thing to emphasize freedom and spontaneity in the early years of school work; but the practical question is constantly forcing itself upon educators: When shall we require coordination? How early shall all the powers of the child be concentrated upon a given task? If the author would elaborate his treatise on the primary school, going into greater detail, and base all his conclusions upon clearly evident scientific facts, it would be of incalculable benefit to education. But if matters are left in the form in which they are in this chapter it is to be feared that more distraction and discouragement than anything else will be the result.

It is cause for regret that the author is so hopeless about education as it is at present conducted. And it is not so much what he says explicitly as the feeling which his words inspire. It seems as if every teacher was to be blamed for some grave error. The reading of the chapter makes one feel that Dr. Oppenheim believes in the fall of man, instead of in his constant ascendancy from lower to higher things. When one gets this latter point of view, he is apt to be more sympathetic toward the failure of the race to realize in practice the highest present ideals in education or in other matters. He sees that we are eternally progressing, and when he criticises his words do not have such a sting; they do not arouse so much antagonism within one as they are otherwise liable to do.

The chapters upon The Child's Development as a Factor in Producing the Genius or the Defective and the Child as a Witness in Suits at

Law are both interesting and important for education. In the first is pointed out clearly the danger of extraordinary development in some narrow channel which may produce a genius, but which is liable to bring forth an unbalanced, defective personality. In the second chapter the inability of the child to observe critically and report truthfully concerning the things and phenomena which he witnesses is convincingly discussed. The absurdity of accepting the testimony of the young child in important suits at law is a matter which has escaped the attention of people too fully in the past. The chapter upon The Place of Religion in the Development of the Child seems, for the most part, to be thoroughly reasonable and of practical value as showing how fruitless, not to say vicious, much of our religious teaching is; although it appears to the writer that the author here departs in one respect from the primary principle which he has been emphasizing throughout the book—namely, that in the training of the child we are at all times to accommodate our instruction to his stage of development and not try to force him up into the atmosphere of the adult by too rapid degrees. But Dr. Oppenheim contends that it would be better to teach the child ethics and a rational (rational to the adult, that is) notion of religion at the outset, rather than the mythological perversions which he is apt to acquire as a result of present methods. But is not an ethical view of the world the product of the highest forms of civilization? and, hence, is it not preceded in ontogenesis, as it was in phylogenesis, by a mythopoeic conception of the universe? Is it not necessary, then, that the child should pass through a stage of nature-worship and animism before he can be introduced to the relatively abstruse and unintelligible propositions of Dr. Oppenheim's religion and ethics? It seems altogether likely that the only way to attain the higher reaches in this, as in other matters, is by way of the lower strata.

On the whole, this book will be of the greatest worth to education in and out of school, and it is to be hoped that it is but the forerunner of others of the same general character, presenting in comprehensible manner the physician's knowledge of the laws governing the



growth of children, and, founded thereupon, his views of the proper materials and methods of school and home instruction.

There are some intelligent people who conscientiously question the value to teachers and parents of child-study in the mass; but there is probably no one who doubts the supreme value to the instructor of any knowledge which will confer upon him a better understanding of the individual child. It is probably true that, all things being viewed together, the most practical phases of this work relate to the study of individuality, since the parent or teacher is especially concerned with the proper training of each child under her care rather than with the elaboration of a science of any kind. Consequently, a book which would in a concrete, scientific way instruct tutors in the difficult art of deciphering the essential characteristics of individual children would be exceptionally helpful in teaching. Dr. Warner's *The Study of Children* accomplishes this in an excellent manner, so far as what might perhaps be styled the hygiene of individuals is concerned. It is devoted almost wholly to a delineation of the modes in which defective or depleted cerebral conditions manifest themselves through bodily expressions. Of course, this does not include all of what the teacher and parent ought to know of individual children; but it certainly deals with the most important factor. One would not go far astray in saying that if an instructor could determine when his children were not in such a condition of health and vigor as to profit best by his teaching, and if he could then apply healing and restorative agencies—if an instructor could do this he would satisfactorily fulfill the most important part of his mission. *The Study of Children* is admirably adapted to give one the power to detect cerebral incapacities in individual children and to suggest in some measure how these may be remedied.

After an introductory chapter and one treating of the body of the child, particular attention being given herein to defects of vision, hearing and breathing, the book proceeds with a description of the architecture and function of the elements of the nervous system, leading up to a science of bodily expression wherein is

pointed out, in the first place, the connection between abnormal fashioning of head and features and defective brain construction, causing some sort of deficiency or estrangement in mental action. It is possible that the author attaches too great importance to the value of physiognomy, especially as it would be employed in the hands of an unskilled person; but he is on thoroughly scientific and therefore safe ground when he shows in detail how given motor activities denote correlated cerebral processes as these relate to healthful or diseased neural conditions. The chapters upon *Observing the Child; What to Look at and What to Look for; Principles of the Methods of Observing and Describing Children; Points for Observation, Indicating Faults in Body or Brain Action or a Status Below the Normal; Examination of Mental Ability and the Faults that may be Observed; and Some General Conditions in Children Described*, are of the greatest worth, because of the admirably concrete way in which the methods of reading expression are delineated.

It is not too much to say that any parent or teacher, upon a careful reading of this book, will be able to deal more wisely with the children intrusted to his care; for he will learn to interpret certain outward expressions as indicative of inner depletion or defect; and he will then not make the mistake, which we know is so often committed, of trying to correct misdeeds by dealing with them as though they were due to perversions of the will instead of being the legitimate issue of disturbing physiological causes. To the writer there is no department of this activity in the study of children which seems of more importance than this which we are now considering; for the reason that education is charged with the responsibility of elevating every individual to the highest possible point of usefulness to himself, and so to society, and this may be accomplished in the case of defectives only when we can apprehend the obstacles to their progress and remove them. And then, even in normal child life, there are so many activities that really at times appear abnormal to the unpracticed eye because of the blighting effects of neural fatigue. In view of these things, then, Dr. Warner's book cannot be too

highly commended to all those who are in immediate contact with childhood in the function of director of any sort.

M. V. O'SHEA.

UNIVERSITY OF WISCONSIN.

*Biomechanik, erschlossen aus dem Principe der Organogenese.* ERNST MEHNERT. Jena, G. Fischer. 1898. Pp. 177. Mk. 5.

The work before us has two purposes: first, to set forth additional evidence for the 'Principe der Organogenese,' already enunciated in the author's work on 'Kainogenese als Ausdruck differenter phylogenetischer Energien,' 1897; and, secondly, to apply this principle to organic evolution. As one can imagine from the ground covered, the work is one of those more or less interesting webs of speculation which even some of the trained German naturalists are fond of spinning at great length.

The principle of organogenesis is thus stated by the author: The rapidity of the ontogenetic process of unfolding of an organ is proportional to the height of phylogenetic development which it has attained at the time. It uniformly increases with the elevation above, and uniformly diminishes with the relinquishment of, a once attained height of development. The meaning of this principle may be made clearer by a few examples. According to the law of recapitulation of phylogeny in ontogeny we should expect a phylogenetically older organ to appear in ontogeny before a phylogenetically younger one. Thus, the great blood vessels of the vertebrate body are doubtless phylogenetically older than the heart and we should expect them to arise before it. But, on the contrary, the heart, because it has attained a higher development than the blood vessels, unfolds in ontogeny first. Its formation has been accelerated. On the other hand, the pineal eye, which is probably derived from that of Tunicates and is, consequently, older than, or at least as old, as the paired eyes, arises in ontogeny later than the paired eyes. Its unfolding has become retarded since the organ has become degenerate. The author, whose view is pretty well limited to vertebrates, tabulates some 33 cases of similar acceleration of physiologically important organs and retardation of physiologically degenerating organs.

This principle of ontogenesis, while not entirely original with the author, is elaborated by him more than it has been heretofore, and especial attention is directed to the fact that the action of this principle nullifies many inferences concerning ancestral conditions drawn from the time of appearing, or the relative size at a given age, of particular organs. Thus it has been argued from the fact that children at birth have proportionately larger brains than adults that the relative size of the brain is diminishing in the human race. According to Mehnert's principle, however, the relatively early attainment of a great size by the human brain indicates that it is a phylogenetically progressing organ, which is certainly a more reasonable as well as a more agreeable conclusion.

Starting from this principle Mehnert now attempts to explain phylogenesis thereby. Here he takes the position of a Neo-Lamarckian in respect to the inheritance of acquired characters, while he accepts Weismann's general conception of preformation in the germ by means of determinants. Individual development proceeds under the influence of two factors. One of them consists of inherited qualities whose development is the 'unfolding of phylogenetic energies;' with this has become associated the second factor, the contribution of those cells which have been added under the special influence of the functional activity of the individual; this is the epigenetic factor. The difficulty of seeing how the acquired characters—the epigenetic factor—are inherited is surmounted in this way: Inheritance is not due merely to a certain chemical constitution of the germ plasma, but also to its physical condition. The molecules of the germ exert a formative influence over each other, much as a bar magnet does over the magnetic field. Now, the quality of this influence is modifiable by the surrounding soma, much as a piece of iron in a modern warship is affected by the distribution and varying conditions of all surrounding masses of the metal. This (chiefly physical) effect of soma upon germ may determine certain qualities in the unfolding of the germ.

And here is where the principle of organogenesis comes in. When an organ is much

used and becomes larger an effect is exerted on the germ such that the organ tends to develop to a larger size in the next generation, and this peculiarity will in later generations be developed earlier and earlier in embryonic life, becoming at the same time more stably heritable.

The work is full of interesting facts, is written in a fairly readable style and is accompanied by an extensive 'Litteraturverzeichnis' of over 11 pages. While one may question the validity of the theory and find the explanation of inheritance of acquired characters vague and unsatisfactory, still we can hardly regard such an attempt as this to draw up a new and complete theory of evolution as entirely in vain.

CHAS. B. DAVENPORT.

#### SCIENTIFIC JOURNALS.

*American Chemical Journal*, October: 'On Some Double Halides of Mercury,' by J. N. Swan. 'The Double Halides of Tin with Aniline and the Toluidines,' by R. L. Slagle. 'On Double Halides of Zinc with Aniline and the Toluidines,' by D. Base. These three papers contain the results of work carried on in the Johns Hopkins University, in the general line which has been under investigation there for a number of years. The field has been thoroughly worked over, and, as a result, many of the compounds described in the literature have been shown to be impure substances or mixtures. 'Sulphonation of the Paraffins,' by R. A. Worstell. The author has found that the sulphonic acid of these hydrocarbons can be easily formed, and he has prepared a number of these acids and their salts. 'The Formation of Hydrazides by the Action of Phenylhydrazine upon Organic Acids in the Cold,' by V. L. Leighton. 'Aliphatic Sulphonic Acids, Ethylenesulphonic Acid,' by E. P. Kohler. The recently discovered gases—'krypton, metargon, neon and coronium'—and 'fermentation without cells' are discussed in the Notes at the end of this number.

J. E. G.

#### SOCIETIES AND ACADEMIES.

GEOLOGICAL CONFERENCE OF HARVARD UNIVERSITY, OCTOBER 4, 1898.

At the opening meeting of the conference general statements concerning the opportu-

nities for advanced geological work in the vicinity of Cambridge were made by the several instructors and two papers were presented.

Dr. J. E. Wolff spoke on 'The Relation of the Granite to the Ore Deposits at Franklin Furnace, New Jersey.' The problem discussed was the relative age of the zinc ores and the granite. According to one theory the ore, granite, limestone and associated secondary minerals are all contemporaneous. While by the other the ore dates from the time the granite was intruded. Dr. Wolff recently observed the contacts between several dikes of granite and the ore body, at the nine hundred and fifty-foot level, Parker Shaft, which were in some cases parallel and in others transverse to the parallel-banded structure of the ore. The granite, in places, showed a finer grain at the contact, a contact zone of garnet and indurated ore, tending to show the intrusion of the granite into the pre-existing ore body.

Dr. R. A. Daly introduced a future illustrated paper on the Volga River, with a sketch of the Physiography of Russia. In travelling across the great basin of Russia one may find evidence of three well defined periods of denudation. The first resulted in the peneplain upon the crystalline foundation which underlies, everywhere and at no great distance from the surface, the Palæozoic and later sediments; the second culminated in Triassic time, and the third is still in progress. The last is marked by a maturely developed peneplain of constant altitude, and remarkable continuity.

J. M. BOUTWELL,

*Recording Secretary pro tempore.*

#### NEW BOOKS.

- A Text-book of Mineralogy.* EDWARD SALISBURY DANA. New York, John Wiley & Sons; London, Chapman & Hall, Limited. 1898. New Edition. Pp. vii + 593. \$4.00.
- Radiation.* H. H. FRANCIS HYNDMAN and SILVANUS P. THOMPSON. London, Swan & Sonnenschein; New York, The Macmillan Company. 1898. Pp. xviii + 307.
- North America.* FRANK G. CARPENTER. New York, The American Book Company. 1898. Pp. 352.



# SCIENCE

EDITORIAL COMMITTEE: S. NEWCOMB, Mathematics; R. S. WOODWARD, Mechnames; E. C. PICKERING Astronomy; T. C. MENDENHALL, Physics; R. H. THURSTON, Engineering; IRA REMSEN, Chemistry; J. LE CONTE, Geology; W. M. DAVIS, Physiography; O. C. MARSH, Paleontology; W. K. BROOKS, C. HART MERRIAM, Zoology; S. H. SCUDDER, Entomology; C. E. BESSEY, N. L. BRITTON, Botany; HENRY F. OSBORN, General Biology; C. S. MINOT, Embryology, Histology; H. P. BOWDITCH, Physiology; J. S. BILLINGS, Hygiene; J. MCKEEN CATTELL, Psychology; DANIEL G. BRINTON, J. W. POWELL, Anthropology.

FRIDAY, OCTOBER 28, 1898.

ADDRESS OF THE PRESIDENT BEFORE THE  
BRITISH ASSOCIATION FOR THE AD-  
VANCEMENT OF SCIENCE, BRIS-  
TOL, 1898.

## CONTENTS:

<i>Address of the President before the British Association for the Advancement of Science, Bristol, 1898</i> (L.): SIR WILLIAM CROOKES .....	561
<i>Variations in the Rate of Agricultural Productions and One of their Causes:</i> JOHN HYDE .....	575
<i>On the Reappearance of the Tile-fish (Lopholatilus chamaeleonticeps):</i> PROFESSOR H. C. BUMPUS.....	576
<i>Seriation Curves of the Cephalic Index:</i> DR. WILLIAM Z. RIPLEY .....	578
<i>The International Conference on Terrestrial Magnetism:</i> C. A. SCHIOTT .....	582
<i>The Tenth Annual Meeting of the Association of Economic Entomologists:</i> C. L. MARLATT.....	584
<i>Notes on Inorganic Chemistry:</i> J. L. H.....	585
<i>Botanical Notes:—</i>	
<i>A Study of Toadstools; A Southern Fern far from Home; The Function of Bloom; A Tiny Pine Tree:</i> PROFESSOR CHARLES E. BESSEY.....	587
<i>Current Notes on Anthropology:—</i>	
<i>Botanical Knowledge of the Ancient Aztecs; Sexual Dimorphism in Man; Heredity; A Contrast:</i> PROFESSOR D. G. BRINTON .....	588
<i>Scientific Notes and News:—</i>	
<i>The Conference on an International Catalogue of Scientific Literature; General.....</i>	589
<i>University and Educational News.....</i>	594
<i>Discussion and Correspondence:—</i>	
<i>A Rule for Finding the Day of the Week: EDWARD L. STABLER. An Apple Canker: W. PADDOCK. Wampum Belts: W. M. BEAUCHAMP.....</i>	594
<i>Scientific Literature:—</i>	
<i>Detmer's Plant Physiology: PROFESSOR J. C. AETHUR. Classen's Quantitative Chemical Analysis by Electrolysis; Oettel's Electro-chemical Experiments and Exercises in Electro-chemistry: H. C. J.....</i>	597
<i>Scientific Journals.....</i>	599
<i>New Books.....</i>	600

## I.

FOR the third time in its history the British Association meets in your City of Bristol. The first meeting was held under the presidency of the Marquis of Lansdowne in 1836, the second under the presidency of Sir John Hawkshaw in 1875. Formerly the President unrolled to the meeting a panorama of the year's progress in physical and biological sciences. To-day the President usually restricts himself to specialities connected with his own work or deals with questions which for the time are uppermost. To be President of the British Association is undoubtedly a great honor. It is also a great opportunity and a great responsibility; for I know that, on the wings of the press, my words, be they worthy or not, will be carried to all points of the compass. I propose first to deal with the important question of the supply of bread to the inhabitants of these islands, then to touch on subjects to which my life work has been more or less devoted. I shall not attempt any general survey of the sciences; these, so far as the progress in them demands attention, will be more fitly brought before you in the different sections, either in the addresses of the presidents or in communications from members.

Before proceeding with my address I wish to refer to the severe loss the British Association has sustained in the death of Lord Playfair. With Sir John Lubbock and Lord Rayleigh, Lord Playfair was one of the permanent trustees of our Association, and for many years he was present at our meetings. It would be difficult to overrate his loss to British science. Lord Playfair's well-matured and accurate judgment, his scientific knowledge, and his happy gift of clothing weighty thoughts in persuasive language, made his presence acceptable, whether in the council chamber, in departmental enquiries, or at light social gatherings, where, by the singular laws of modern society, momentous announcements are sometimes first given to the world. Lord Playfair (then Sir Lyon Playfair) was President of the British Association at Aberdeen in 1885; his address on that occasion will long be remembered as a model of profound learning and luminous exposition.

And now I owe a sort of apology to this brilliant audience. I must ask you to bear with me for ten minutes, for I am afraid what I now have to say will prove somewhat dull. I ought to propitiate you, for, to tell the truth, I am bound to bore you with figures. Statistics are rarely attractive to a listening audience; but they are necessary evils, and those of this evening are unusually doleful. Nevertheless, when we have proceeded a little way on our journey, I hope you will see that the river of figures is not hopelessly dreary. The stream leads into an almost unexplored region, and to the right and left we see channels opening out, all worthy of exploration and promising a rich reward to the statistic explorer who will trace them to their source—a harvest, as Huxley expresses it, 'immediately convertible into those things which the most sordidly practical of men will admit to have value, namely, money and life.' My chief

subject is of interest to the whole world—to every race, to every human being. It is of urgent importance to-day, and it a life-and-death question for generations to come. I mean the question of food supply. Many of my statements you may think are of the alarmist order; certainly they are depressing, but they are founded on stubborn facts. They show that England and all civilized nations stand in deadly peril of not having enough to eat. As mouths multiply, food resources dwindle. Land is a limited quantity, and the land that will grow wheat is absolutely dependent on difficult and capricious natural phenomena. I am constrained to show that our wheat-producing soil is totally unequal to the strain put upon it. After wearying you with a survey of the universal dearth to be expected, I hope to point a way out of the colossal dilemma. It is the chemist who must come to the rescue of the threatened communities. It is through the laboratory that starvation may ultimately be turned into plenty.

The food supply of the kingdom is of peculiar interest to this meeting, considering that the grain trade has always been, and still is, an important feature in the imports of Bristol. The imports of grain to this city amount to about 25,000,000 bushels per annum, 8,000,000 of which consist of wheat.

What are our home requirements in the way of wheat? The consumption of wheat per head of the population (unit consumption) is over six bushels per annum; and taking the population at 40,000,000, we require no less than 240,000,000 bushels of wheat, increasing annually by 2,000,000 bushels, to supply the increase of population. Of the total amount of wheat consumed in the United Kingdom we grow 25 and import 75 per cent.

So important is the question of wheat supply that it has attracted the attention of Parliament, and the question of national granaries has been mooted. It is certain

that in case of war with any of the Great Powers wheat would be contraband, as if it were cannon or powder, liable to capture even under a neutral flag. We must, therefore, accept the situation and treat wheat as munitions of war, and grow, accumulate or store it as such. It has been shown that at the best our stock of wheat and flour amounts only to 64,000,000 bushels—fourteen weeks' supply—while last April our stock was equal to only 10,000,000 bushels, the smallest ever recorded by 'Beerbohm' for the period of the season. Similarly, the stocks held in Europe, the United States and Canada, called 'the world's visible supply,' amounted to only 54,000,000 bushels, or 10,000,000 less than last year's sum-total, and nearly 82,000,000 less than that of 1893 or 1894 at the corresponding period. To arrest this impending danger, it has been proposed that an amount of 64,000,000 bushels of wheat should be purchased by the State and stored in national granaries, not to be opened, except to remedy deterioration of grain, or in view of national disaster rendering starvation imminent. This 64,000,000 bushels would add another fourteen weeks' life to the population; assuming that the ordinary stock had not been drawn on, the wheat in the country would only then be enough to feed the population for twenty-eight weeks.

I do not venture to speak authoritatively on national granaries. The subject has been discussed in the daily press, and the recently published report from the Agricultural Committee on National Wheat Stores brings together all the arguments in favor of this important scheme, together with the difficulties to be faced if it be carried out with necessary completeness.

More hopeful, although difficult and costly, would be the alternative of growing most, if not all, of our own wheat supply here at home in the British Isles. The average

yield over the United Kingdom last year was 29.07 bushels per acre, the average for the last eleven years being 29.46. For twelve months we need 240,000,000 bushels of wheat, requiring about 8,250,000 acres of good wheat-growing land, or nearly 13,000 square miles, increasing at the rate of 100 square miles per annum, to render us self-supporting as to bread food. This area is about one-fourth the size of England.

A total area of land in the United Kingdom equal to a plot 110 miles square, of quality and climate sufficient to grow wheat to the extent of 29 bushels per acre, does not seem a hopeless demand.\* It is doubtful, however, if this amount of land could be kept under wheat, and the necessary expense of high farming faced, except under the imperious pressure of impending starvation or the stimulus of a national subsidy or permanent high prices. Certainly these 13,000 square miles would not be available under ordinary economic conditions, for much, perhaps all, the land now under barley and oats would not be suitable for wheat. In any case, owing to our cold, damp climate and capricious weather, the wheat crop is hazardous, and for the present our annual deficit of 180,000,000 bushels must be imported. A permanently higher price for wheat is, I fear, a calamity that ere long must be faced. At enhanced prices land now under wheat will be better farmed, and therefore will yield better, thus giving increased production without increased area.

The burning question of to-day is: What can the United Kingdom do to be reasonably safe from starvation in presence of two successive failures of the world's wheat harvest, or against a hostile combination of European nations? We eagerly spend millions

\* The total area of the United Kingdom is 120,979 square miles; therefore the required land is about a tenth part of the total.



to protect our coasts and commerce, and millions more on ships, explosives, guns and men; but we omit to take necessary precautions to supply ourselves with the very first and supremely important munition of war—food.

To take up the question of food supply in its scientific aspect, I must not confine myself exclusively to our own national requirements. The problem is not restricted to the British Isles—the bread-eaters of the whole world share the perilous prospect—and I do not think it out of place if on this occasion I ask you to take with me a wide, general survey of the wheat supply of the whole world.

Wheat is the most sustaining food grain of the great Caucasian race, which includes the peoples of Europe, United States, British America, the white inhabitants of South Africa, Australasia, parts of South America, and the white population of the European colonies. Of late years the individual consumption of wheat has almost universally increased. In Scandinavia it has risen 100 per cent. in twenty-five years; in Austro-Hungary, 80 per cent.; in France, 20 per cent.; while in Belgium it has increased 50 per cent. Only in Russia and Italy, and possibly Turkey, has the consumption of wheat per head declined.

In 1871 the bread-eaters of the world numbered 371,000,000. In 1881 the numbers rose to 416,000,000; in 1891, to 472,600,000, and at the present time they number 516,500,000. The augmentation of the world's bread-eating population in a geometrical ratio is evidenced by the fact that the yearly aggregates grow progressively larger. In the early seventies they rose 4,300,000 per annum, while in the eighties they increased by more than 6,000,000 per annum, necessitating annual additions to the bread supply nearly one-half greater than sufficed twenty-five years ago.

How much wheat will be required to supply all these hungry mouths with bread? At the present moment it is not possible to get accurate estimates of this year's wheat crops of the world, but an adequate idea may be gained from the realized crops of some countries and the promise of others. To supply 516,500,000 bread-eaters, if each bread-eating unit is to have his usual ration, will require a total of 2,324,000,000 bushels for seed and food. What are our prospects of obtaining this amount?

According to the best authorities the total supplies from the 1897-98 harvest are 1,921,000,000 bushels. The requirement of the 516,500,000 bread-eaters for seed and food are 2,324,000,000 bushels; there is thus a deficit of 403,000,000 bushels, which has not been urgently apparent owing to a surplus of 300,000,000 bushels carried over from the last harvest. Respecting the prospects of the harvest year just beginning it must be borne in mind that there are no remainders to bring over from last harvest. We start with a deficit of 103,000,000 bushels and have 6,500,000 more mouths to feed. It follows, therefore, that one-sixth of the required bread will be lacking unless larger drafts than now seem possible can be made upon early produce from the next harvest.

The majority of the wheat crops between 1882 and 1896 were in excess of current needs, and thus considerable reserves of wheat were available for supplementing small deficits from the four deficient harvests. But bread-eaters have almost eaten up the reserves of wheat, and, the 1897 harvest being under average, the conditions become serious. That scarcity and high prices have not prevailed in recent years is due to the fact that since 1889 we have had seven world crops of wheat and six of rye abundantly in excess of the average. These generous crops increased accumulations to

such an extent as to obscure the fact that the harvests of 1895 and 1896 were each much below current requirements. Practically speaking, reserves are now exhausted, and bread-eaters must be fed from current harvests, accumulation under present conditions being almost impossible. This is obvious from the fact that a harvest equal to that of 1894 (the greatest crop on record, both in acre-yield and in the aggregate) would yield less than current needs.

It is clear we are confronted with a colossal problem that must tax the wits of the wisest. When the bread-eaters have exhausted all possible supplies from the 1897-98 harvest there will be a deficit of 103,000,000 bushels of wheat, with no substitution possible unless Europeans can be induced to eat Indian corn or rye bread. Up to recent years the growth of wheat has kept pace with demands. As wheat-eaters increased, the acreage under wheat expanded. The world has become so familiarized with the orderly sequence of demand and supply, so accustomed to look upon the vast plains of other wheat-growing countries as inexhaustible granaries, that, in a light hearted way, it is taken for granted that so many million additional acres can be added year after year to the wheat-growing area of the world. We forget that the wheat-growing area is of strictly limited extent, and that a few million acres regularly absorbed soon mount to a formidable number.

The present position being so gloomy, let us consider future prospects. What are the capabilities as regards available area, economic conditions and acreage-yield of the wheat-growing countries from whence we now draw our supply?

For the last thirty years the United States have been the dominant factor in the foreign supply of wheat, exporting no less than 145,000,000 bushels. This shows

how the bread-eating world has depended, and still depends, on the United States for the means of subsistence. The entire world's contributions to the food-bearing area have averaged but 4,000,000 acres yearly since 1869. It is scarcely possible that such an average, under existing conditions, can be doubled for the coming twenty-five years. Almost yearly, since 1885, additions to the wheat-growing area have diminished, while the requirements of the increasing population of the States have advanced, so that the needed American supplies have been drawn from the acreage hitherto used for exportation. Practically there remains no uncultivated prairie land in the United States suitable for wheat-growing. The virgin land has been rapidly absorbed, until at present there is no land left for wheat without reducing the area for maize, hay and other necessary crops.

It is almost certain that within a generation the ever-increasing population of the United States will consume all the wheat grown within its borders, and will be driven to import, and, like ourselves, will scramble for a lion's share of the wheat crop of the world. This being the outlook, exports of wheat from the United States are only of present interest, and will gradually diminish to a vanishing point. The inquiry may be restricted to such countries as probably will continue to feed bread-eaters who annually derive a considerable part of their wheat from extraneous sources.

But if the United States, which grows about one-fifth of the world's wheat, and contribute one-third of all wheat exportations, are even now dropping out of the race, and likely soon to enter the list of wheat-importing countries, what prospect is there that other wheat-growing countries will be able to fill the gap, and, by enlarging their acreage under wheat, replace the supply which the States have so long con-

tributed to the world's food? The withdrawal of 145,000,000 bushels will cause a serious gap in the food supply of wheat-importing countries, and unless this deficit can be met by increased supplies from other countries there will be a dearth for the rest of the world after the British Isles are sufficiently supplied.

Next to the United States, Russia is the greatest wheat exporter, supplying nearly 95,000,000 bushels.

Although Russia at present exports so lavishly, this excess is merely provisional and precarious. The Russian peasant population increases more rapidly than any other in Europe. The yield per acre over European Russia is meagre—not more than 8.6 bushels to the acre—while some authorities consider it as low as 4.6 bushels. The cost of production is low—lower even than on the virgin soils of the United States. The development of the fertile though somewhat overrated 'black earth,' which extends across the southern portion of the Empire and beyond the Ural Mountains into Siberia, progresses rapidly. But, as we have indicated, the consumption of bread in Russia has been reduced to danger point. The peasants starve and fall victims to 'hunger typhus,' whilst the wheat growers export grain that ought to be consumed at home.

Considering Siberia as a wheat grower, climate is the first consideration. Summers are short—as they are in all regions with continental climates north of the 45th parallel—and the ripening of wheat requires a temperature averaging at least 65° Fahr. for fifty-five to sixty-five days. As all Siberia lies north of the summer isotherm of 65°, it follows that such region is ill adapted to wheat culture unless some compensating climatic condition exists. As a fact, the conditions are exceptionally unfavorable in all but very limited districts in the two west-

ernmost governments. The cultivatable lands of western Siberia adapted to grain-bearing equal neither in extent nor in potential productive powers those of Iowa, Minnesota and Nebraska. There are limited tracts of fair productiveness in central Siberia and in the valleys of the southern affluents of the Amoor, but these are only just capable of supporting a meager population.

Prince Hilkoﬀ, Russian Minister of Ways and Communications, declared in 1896 that "Siberia never had produced, and never would produce, wheat and rye enough to feed the Siberian population." And, a year later, Prince Krapotkin backed the statement as substantially correct.

Those who attended the meeting of the British Association last year in Canada must have been struck with the extent and marvellous capacity of the fertile plains of Manitoba and the Northwest Provinces. Here were to be seen 1,290,000 acres of fine wheat-growing land yielding 18,261,950 bushels, one-fifth of which comes to hungry England. Expectations have been cherished that the Canadian Northwest would easily supply the world with wheat, and exaggerated estimates are drawn as to the amount of surplus land on which wheat can be grown. Thus far performance has lagged behind promise, the wheat-bearing area of all Canada having increased less than 500,000 acres since 1884, while the exports have not increased in greater proportion. As the wheat area of Manitoba and the Northwest has increased, the wheat area of Ontario and the Eastern Provinces has decreased, the added acres being little more than sufficient to meet the growing requirements of population. We have seen calculations showing that Canada contains 500,000,000 acres of profitable wheat land. The impossibility of such an estimate ever being fulfilled will be apparent when it is remembered that the whole area employed in both



temperate zones for growing all the stable food crops is not more than 580,000,000 acres, and that in no country has more than 9 per cent. of the area been devoted to wheat culture.

The fertility of the Northwest Provinces of the Dominion is due to an exceptional and curious circumstance. In winter the ground freezes to a considerable depth. Wheat is sown in the spring, generally in April, when the frozen ground has been thawed to a depth of three inches. Under the hot sun of the short summer the grain sprouts with surprising rapidity, partly because the roots are supplied with water from the thawing depths. The summer is too short to thaw the ground thoroughly, and gate-posts or other dead wood extracted in autumn are found still frozen at their lower end.

Australasia, as a potential contributor to the world's supply of wheat, affords another fertile field for speculation. Climatic conditions limit the Australian wheat area to a small portion of the southern littoral belt. Professor Shelton considers there are still fifty million acres in Queensland suitable for wheat, but hitherto it has never had more than 150,000 acres under cultivation. Crops in former days were liable to rust, but, since the Rust in Wheat, conferences, and the dissemination of instruction to farmers, rust no longer has any terrors. I am informed by the Queensland Department of Agriculture that of late years they have practically bred wheat vigorous enough to resist this plague. For the second season in succession the wheat crop last year was destroyed over large areas in Victoria; and in South Australia the harvest averaged not more than about  $3\frac{3}{4}$  bushels per acre after meeting Colonial requirements for food and seed, leaving only 684,000 bushels for export. In most other districts the yield falls to such an extent as to cause Europeans to

wonder why the pursuit of wheat-raising is continued.

New Zealand has a moist climate resembling that of central and southern England, while South Australia is semi-arid, resembling western Kansas. Only two countries in the world yield as much wheat per acre as New Zealand; these are Denmark and the United Kingdom. Notwithstanding the great yield of wheat, due to an equable climate, New Zealand finds fruit and dairy farming still more profitable. The climatic conditions favorable to wheat are also conducive to luxuriant growths of nutritious grasses. Thus the New Zealander ships his butter more than half way round the world, and competes successfully with western Europe.

During the last twenty-seven years the Austro-Hungarian population has increased 21.8 per cent., as against an increase of 54.6 per cent. in the acreage of wheat. Notwithstanding this disparity in the rates or increase, exports have practically ceased by reason of an advance of nearly 80 per cent. in unit consumption. There can be little doubt that Austro-Hungary is about to enter the ranks of importing nations, although in Hungary a considerable area of wheat land remains to be brought under cultivation.

Roumania is an important wheat-growing country. In 1896 it produced 69,000,000 bushels and exported 34,000,000 bushels. It has a considerable amount of surplus land which can be used for wheat, although for many years the wheat area is not likely to exceed home requirements.

France comes next to the United States as a producer of wheat; but for our purpose she counts but little, being dependent on supplies from abroad for an average quantity of 14 per cent. of her own production. There is practically no spare land in France that can be put under wheat in sufficient

quantity to enable her to do more than provide for increase of population.

Germany is a gigantic importer of wheat, her imports rising 700 per cent. in the last twenty-five years, and now averaging 35,000,000 bushels. Other nations of Europe, also importers, do not require detailed mention, as under no conceivable conditions would they be able to do more than supply wheat for the increasing requirements of their local population, and, instead of replenishing, would probably diminish, the world's stores.

The prospective supply of wheat from Argentina and Uruguay has been greatly overrated. The agricultural area includes less than 100,000,000 acres of good, bad and indifferent land, much of which is best adapted for pastoral purposes. There is no prospect of Argentina ever being able to devote more than 30,000,000 acres to wheat; the present wheat area is about 6,000,000 acres, an area that may be doubled in the next twelve years. But the whole arable region is subject to great climatic vicissitudes and to frosts that ravage the fields south of the thirty-seventh parallel. Years of systematized energy are frustrated in a few days—perhaps hours—by a single cruelty of Nature, such as a plague of locusts, a tropical rain or a devastating hail storm. It will take years to bring the surplus lands of Argentina into cultivation, and the population is even now insufficient to supply labor at seed time and harvest.

During the next twelve years Uruguay may add a million acres to the world's wheat fields; but social, political and economic conditions seriously interfere with agricultural development.

At the present time South Africa is an importer of wheat, and the regions suitable to cereals do not exceed a few million acres. Great expectations have been formed as to the fertility of Mashonaland, the Shire

Highlands and the Kikuyu plateau, and as to the adaptation of these regions to the growth of wheat. But wheat culture fails where the banana ripens, and the banana flourishes throughout Central Africa, except in limited areas of great elevation. In many parts of Africa insect pests render it impossible to store grain, and without grain-stores there can be little hope of large exports.

North Africa, formerly the granary of Rome, now exports less than 5,000,000 bushels of wheat annually, and these exports are on the decline, owing to increased home demands. With scientific irrigation, Egypt could supply three times her present amount of wheat, although no increase is likely unless the cotton fields of the Delta are diverted to grain growing. In Algeria and Tunis nearly all reclaimed lands are devoted to the production of wine, for which a brisk demand exists. Were this land devoted to the growth of wheat an additional five million bushels might be obtained.

The enormous acreage devoted to wheat in India has been declining for some years, and in 1895 over 20,000,000 acres yielded 185,000,000 bushels. Seven-eighths of this harvest is required for native consumption, and only one-eighth on an average is available for export. The annual increase of population is more than 3,000,000, demanding an addition to the food-bearing lands of not less than 1,800,000 acres annually. In recent years the increase has been less than one-fourth of this amount.

In surveying the limitations and vicissitudes of wheat crops, I have endeavored to keep free from exaggeration, and have avoided insistence on doubtful points. I have done my best to get trustworthy facts and figures, but from the nature of the case it is impossible to attain complete accuracy. Great caution is required in sifting the numerous varying current statements respect-

ing the estimated areas and total produce of wheat throughout the world. The more closely official estimates are examined, the more defective are they found, and comparatively few figures are sufficiently well established to bear the deductions often drawn. In doubtful cases I have applied to the highest authorities in each country, and in the case of conflicting accounts have taken data the least favorable to sensational or panic-engendering statements. In a few instances of accurate statistics their value is impaired by age; but for 95 per cent. of my figures I quote good authorities, while for the remaining 5 per cent. I rely on the best commercial estimates derived from the appearance of the growing crops, the acreage under cultivation and the yield last year. The maximum probable error would make no appreciable difference in my argument.

The facts and figures I have set before you are easily interpreted. Since 1871 unit consumption of wheat, including seed, has slowly increased in the United Kingdom to the present amount of six bushels per head per annum; while the rate of consumption for seed and food by the whole world of bread-eaters was 4.15 bushels per unit per annum for the eight years ending 1878, and at the present time is 4.5 bushels. Under present conditions of low acre yield, wheat cannot long retain its dominant position among the food-stuffs of the civilized world. The details of the impending catastrophe no one can predict, but its general direction is obvious enough. Should all the wheat-growing countries add to their area to the utmost capacity, on the most careful calculation the yield would give us only an addition of some 100,000,000 acres, supplying at the average world-yield of 12.7 bushels to the acre, 1,270,000,000 bushels, just enough to supply the increase of population among bread-eaters till the year 1931.

At the present time there exists a deficit

in the wheat area of 31,000 square miles—a deficit masked by the fact that the ten world crops of wheat harvested in the ten years ending 1896 were more than 5 per cent. above the average of the previous twenty-six years.

When provision shall have been made, if possible, to feed 230,000,000 units likely to be added to the bread-eating populations by 1931—by the complete occupancy of the arable areas of the temperate zone now partially occupied—where can be grown the additional 330,000,000 bushels of wheat required ten years later by a hungry world? What is to happen if the present rate of population be maintained, and if arable areas of sufficient extent cannot be adapted and made contributory to the subsistence of so great a host.

Are we to go hungry and to know the trial of scarcity? That is the poignant question. Thirty years is but a day in the life of a nation. Those present who may attend the meeting of the British Association thirty years hence will judge how far my forecasts are justified.

If bread fails—not only us, but all the bread-eaters of the world—what are we to do? We are born wheat-eaters. Other races, vastly superior to us in numbers, but differing widely in material and intellectual progress, are eaters of Indian corn, rice, millet and other grains; but none of these grains have the food value, the concentrated health-sustaining power of wheat, and it is on this account that the accumulated experience of civilized mankind has set wheat apart as the fit and proper food for the development of muscle and brains.

It is said that when other wheat-exporting countries realize that the States can no longer keep pace with the demand, these countries will extend their area of cultivation, and struggle to keep up the supply *pari passu* with the falling off in other quarters. But will this comfortable and cher-



ished doctrine bear the test of examination?

Cheap production of wheat depends on a variety of causes, varying greatly in different countries. Taking the cost of producing a given quantity of wheat in the United Kingdom at 100s., the cost for the same amount in the United States is 67s., in India 66s., and in Russia 54s. We require cheap labor, fertile soil, easy transportation to market, low taxation and rent, and no export or import duties. Labor will rise in price, and fertility diminish as the requisite manurial constituents in the virgin soil become exhausted. Facility of transportation to market will be aided by railways, but these are slow and costly to construct, and it will not pay to carry wheat by rail beyond a certain distance. These considerations show that the price of wheat tends to increase. On the other hand, the artificial impediments of taxation and customs duties tend to diminish as demand increases and prices rise.

I have said that starvation may be averted through the laboratory. Before we are in the grip of actual dearth the chemist will step in and postpone the day of famine to so distant a period that we and our sons and grandsons may legitimately live without undue solicitude for the future.

It is now recognized that all crops require what is called a 'dominant' manure. Some need nitrogen, some potash, others phosphates. Wheat preeminently demands nitrogen, fixed in the form of ammonia or nitric acid. All other necessary constituents exist in the soil; but nitrogen is mainly of atmospheric origin, and is rendered 'fixed' by a slow and precarious process which requires a combination of rare meteorological and geographical conditions to enable it to advance at a sufficiently rapid rate to become of commercial importance.

There are several sources of available nitrogen. The distillation of coal in the process of gas-making yields a certain amount of its nitrogen in the form of ammonia; and this product, as sulphate of ammonia, is a substance of considerable commercial value to gas companies. But the quantity produced is comparatively small; all Europe does not yield more than 400,000 annual tons, and, in view of the unlimited nitrogen required to substantially increase the world's wheat crop, this slight amount of coal ammonia is not of much significance. For a long time guano has been one of the most important sources of nitrogenous manures, but guano deposits are so near exhaustion that they may be dismissed from consideration.

Much has been said of late years, and many hopes raised by the discovery of Hellriegel and Wilfarth, that leguminous plants bear on their roots nodosities abounding in bacteria endowed with the property of fixing atmospheric nitrogen; and it is proposed that the necessary amount of nitrogen demanded by grain crops should be supplied to the soil by cropping it with clover and ploughing in the plant when its nitrogen assimilation is complete. But it is questionable whether such a mode of procedure will lead to the lucrative stimulation of crops. It must be admitted that practice has long been ahead of science, and for ages farmers have valued and cultivated leguminous crops. The four-course rotation is turnips, barley, clover, wheat—a sequence popular more than two thousand years ago. On the Continent, in certain localities, there has been some extension of microbe cultivation; at home we have not reached even the experimental stage. Our present knowledge leads to the conclusion that the much more frequent growth of clover on the same land, even with successful microbe-seeding and proper mineral supplies, would be attended with uncer-

tainty and difficulties. The land soon becomes what is called 'clover sick' and turns barren.

There is still another and invaluable source of fixed nitrogen. I mean the treasure locked up in the sewage and drainage of our towns. Individually the amount so lost is trifling, but multiply the loss by the number of inhabitants, and we have the startling fact that, in the United Kingdom, we are content to hurry down our drains and water courses, into the sea, fixed nitrogen to the value of no less than 16,000,000*l.* per annum. This unspeakable waste continues, and no effective and universal method is yet contrived of converting sewage into corn. Of this barbaric waste of manurial constituents Liebig, nearly half a century ago, wrote in these prophetic words: "Nothing will more certainly consummate the ruin of England than a scarcity of fertilizers—it means a scarcity of food. It is impossible that such a sinful violation of the divine laws of Nature should forever remain unpunished; and the time will probably come for England sooner than for any other country when, with all her wealth in gold, iron and coal, she will be unable to buy one-thousandth part of the food which she has, during hundreds of years, thrown recklessly away."

The more widely this wasteful system is extended, recklessly returning to the sea what we have taken from the land, the more surely and quickly will the finite stocks of nitrogen locked up in the soils of the world become exhausted. Let us remember that the plant creates nothing; there is nothing in bread which is not absorbed from the soil, and, unless the abstracted nitrogen is returned to the soil, its fertility must ultimately be exhausted. When we apply to the land nitrate of soda, sulphate of ammonia or guano we are drawing on the earth's capital, and our drafts will not per-

petually be honored. Already we see that a virgin soil cropped for several years loses its productive powers, and without artificial aid becomes infertile. Thus the strain to meet demands is increasingly great. Witness the yield of forty bushels of wheat per acre under favorable conditions, dwindling through exhaustion of soil to less than seven bushels of poor grain, and the urgency of husbanding the limited store of fixed nitrogen becomes apparent. The store of nitrogen in the atmosphere is practically unlimited, but it is fixed and rendered assimilable by plants only by cosmic processes of extreme slowness. The nitrogen which, with a light heart, we liberate in a battleship broadside has taken millions of minute organisms patiently working for centuries to win from the atmosphere.

The only available compound containing sufficient fixed nitrogen to be used on a world-wide scale as a nitrogenous manure is nitrate of soda, or Chili saltpetre. This substance occurs native over a narrow band of the plain of Tamarugal, in the northern provinces of Chili, between the Andes and the coast hills. In this rainless district, for countless ages, the continuous fixation of atmospheric nitrogen by the soil, its conversion into nitrate by the slow transformation of billions of nitrifying organisms, its combination with soda, and the crystallization of the nitrate, have been steadily proceeding, until the nitrate fields of Chili have become of vast commercial importance, and promise to be of inestimably greater value in the future. The growing exports of nitrate from Chili at present amount to about 1,200,000 tons.

The present acreage devoted to the world's growth of wheat is about 163,000,000 acres. At the average of 12.7 bushels per acre this gives 2,070,000,000 bushels. But thirty years hence the demand will be 3,260,000,000 bushels, and there will be difficulty in finding the necessary acreage

on which to grow the additional amount required. By increasing the present yield per acre from 12.7 to 20 bushels we should, with our present acreage, secure a crop of the requisite amount. Now from 12.7 to 20 bushels per acre is a moderate increase of productiveness, and there is no doubt that a dressing with nitrate of soda will give this increase and more.

The action of nitrate of soda in improving the yield of wheat has been studied practically by Sir John Lawes and Sir Henry Gilbert on their experimental field at Rothamstead. This field was sown with wheat for thirteen consecutive years without manure, and yielded an average of 11.9 bushels to the acre. For the next thirteen years it was sown with wheat, and dressed with 5 cwt. of nitrate of soda per acre, other mineral constituents also being present. The average yield for these years was 36.4 bushels per acre—an increase of 24.5 bushels. In other words, 22.86 pounds of nitrate of soda produce an increase of one bushel of wheat.

At this rate, to increase the world's crop of wheat by 7.3 bushels, about  $1\frac{1}{2}$  cwt. of nitrate of soda must annually be applied to each acre. The amount required to raise the world's crop on 163,000,000 acres from the present supply of 2,070,000,000 bushels to the required 3,260,000,000 bushels will be 12,000,000 tons, distributed in varying amounts over the wheat-growing countries of the world. The countries which produce more than the average of 12.7 bushels will require less, and those below the average will require more; but, broadly speaking, about 12,000,000 tons annually of nitrate of soda will be required, in addition to the 1,250,000 tons already absorbed by the world.

It is difficult to get trustworthy estimates of the amount of nitrate surviving in the nitre beds. Common rumor declares the supply to be inexhaustible, but cautious

local authorities state that at the present rate of export, of over 1,000,000 tons per annum, the raw material 'caliche,' containing from 25 to 50 per cent. nitrate, will be exhausted in from twenty to thirty years.

Dr. Newton, who has spent years on the nitrate fields, tells me there is a lower class material, containing a small proportion of nitrate, which cannot at present be used, but which may ultimately be manufactured at a profit. Apart from a few of the more scientific manufacturers, no one is sanguine enough to think this debatable material will ever be worth working. If we assume a liberal estimate for nitrate obtained from the lower grade deposit, and say that it will equal in quantity that from the richer quality, the supply may last, possibly, fifty years, at the rate of a million tons a year; but at the rate required to augment the world's supply of wheat to the point demanded thirty years hence it will not last more than four years.

I have passed in review all the wheat-growing countries of the world, with the exception of those whose united supplies are so small as to make little appreciable difference to the argument. The situation may be summed up briefly thus: The world's demand for wheat—the leading bread-stuff—increases in a crescendo ratio year by year. Gradually all the wheat-bearing land on the globe is appropriated to wheat-growing, until we are within measurable distance of using the last available acre. We must then rely on nitrogenous manures to increase the fertility of the land under wheat, so as to raise the yield from the world's low average—12.7 bushels per acre—to a higher average. To do this efficiently and feed the bread-eaters for a few years will exhaust all the available store of nitrate of soda. For years past we have been spending fixed nitrogen at a culpably extravagant rate, heedless of the fact that it is fixed with extreme slow-



ness and difficulty, while its liberation in the free state takes place always with rapidity and sometimes with explosive violence.

Some years ago Mr. Stanley Jevons uttered a note of warning as to the near exhaustion of our British coalfields. But the exhaustion of the world's stock of fixed nitrogen is a matter of far greater importance. It means not only a catastrophe little short of starvation for the wheat-eaters, but indirectly, scarcity for those who exist on inferior grains, together with a lower standard of living for meat-eaters, scarcity of mutton and beef, and even the extinction of gunpowder!

There is a gleam of light amid this darkness of despondency. In its free state nitrogen is one of the most abundant and pervading bodies on the face of the earth. Every square yard of the earth's surface has nitrogen gas pressing down on it to the extent of about seven tons; but this is in the *free* state, and wheat demands it *fixed*. To convey this idea in an object-lesson, I may tell you that, previous to its destruction by fire, Colston Hall, measuring 146 feet by 80 feet by 70 feet, contained 27 tons' weight of nitrogen in its atmosphere; it also contained one-third of a ton of argon. In the free gaseous state this nitrogen is worthless; combined in the form of nitrate of soda it would be worth about 2,000*l*.

For years past attempts have been made to effect the fixation of atmospheric nitrogen, and some of the processes have met with sufficient partial success to warrant experimentalists in pushing their trials still further; but I think I am right in saying that no process has yet been brought to the notice of scientific or commercial men which can be considered successful either as regards cost or yield of product. It is possible, by several methods, to fix a certain amount of atmospheric nitrogen; but, to the best of my knowledge, no process has

hitherto converted more than a small amount, and this at a cost largely in excess of the present market value of fixed nitrogen.

The fixation of atmospheric nitrogen, therefore, is one of the great discoveries awaiting the ingenuity of chemists. It is certainly deeply important in its practical bearings on the future welfare and happiness of the civilized races of mankind. This unfulfilled problem, which so far has eluded the strenuous attempts of those who have tried to wrest the secret from Nature, differs materially from other chemical discoveries which are in the air, so to speak, but are not yet matured. The fixation of nitrogen is vital to the progress of civilized humanity. Other discoveries minister to our increased intellectual comfort, luxury or convenience; they serve to make life easier, to hasten the acquisition of wealth, or to save time, health or worry. The fixation of nitrogen is a question of the not-far-distant future. Unless we can class it among certainties to come, the great Caucasian race will cease to be foremost in the world, and will be squeezed out of existence by races to whom wheaten bread is not the staff of life.

Let me see if it is not possible even now to solve the momentous problem. As far back as 1892 I exhibited, at one of the Soirées of the Royal Society, an experiment on 'The Flame of Burning Nitrogen.' I showed that nitrogen is a combustible gas, and the reason why when once ignited the flame does not spread through the atmosphere and deluge the world in a sea of nitric acid is that its igniting point is higher than the temperature of its flame—not, therefore, hot enough to set fire to the adjacent mixture. But by passing a strong induction current between terminals the air takes fire and continues to burn with a powerful flame, producing nitrous and nitric acids. This inconsiderable experiment may not unlikely lead to the development of a mighty industry destined to solve the great

food problem. With the object of burning out nitrogen from air so as to leave argon behind, Lord Rayleigh fitted up apparatus for performing the operation on a larger scale, and succeeded in effecting the union of 29.4 grams of mixed nitrogen and oxygen at an expenditure of one horse-power. Following these figures it would require one Board of Trade unit to form 74 grams of nitrate of soda, and therefore 14,000 units to form one ton. To generate electricity in the ordinary way with steam engines and dynamos, it is now possible, with a steady load night and day, and engines working at maximum efficiency, to produce current at a cost of one-third of a penny per Board of Trade unit. At this rate one ton of nitrate of soda would cost 26*l*. But electricity from coal and steam engines is too costly for large industrial purposes; at Niagara, where water power is used, electricity can be sold at a profit for one-seventeenth of a penny per Board of Trade unit. At this rate nitrate of soda would cost not more than 5*l*. per ton. But the limit of cost is not yet reached, and it must be remembered that the initial data are derived from small-scale experiments, in which the object was not economy, but rather to demonstrate the practicability of the combustion method and to utilize it for isolating argon. Even now electric nitrate at 5*l*. a ton compares favorably with Chili nitrate at 7*l*. 10*s*. a ton, and all experience shows that when the road has been pointed out by a small laboratory experiment the industrial operations that may follow are always conducted at a cost considerably lower than could be anticipated from the laboratory figures.

Before we decide that electric nitrate is a commercial possibility a final question must be mooted. We are dealing with wholesale figures, and must take care that we are not simply shifting difficulties a little further back without really diminishing them. We start with a shortage of wheat,

and the natural remedy is to put more land under cultivation. As the land cannot be stretched, and there is so much of it and no more, the object is to render the available area more productive by a dressing with nitrate of soda. But nitrate of soda is limited in quantity and will soon be exhausted. Human ingenuity can contend even with these apparently hopeless difficulties. Nitrate can be produced artificially by the combustion of the atmosphere. Here we come to finality in one direction; our stores are inexhaustible. But how about electricity? Can we generate enough energy to produce 12,000,000 tons of nitrate of soda annually? A preliminary calculation shows that there need be no fear on that score; Niagara alone is capable of supplying the required electric energy without much lessening its mighty flow.

The future can take care of itself. The artificial production of nitrate is clearly within view, and by its aid the land devoted to wheat can be brought up to the thirty-bushels-per-acre standard. In days to come, when the demand may again overtake supply, we may safely leave our successors to grapple with the stupendous food problem.

And, in the next generation, instead of trusting mainly to food-stuffs which flourish in temperate climates, we probably shall trust more and more to the exuberant food-stuffs of the tropics, where, instead of one yearly sober harvest, jeopardized by any shrinkage of the scanty days of summer weather, or of the few steady inches of rainfall, Nature annually supplies heat and water enough to ripen two or three successive crops of food-stuffs in extraordinary abundance. To mention one plant alone, Humboldt—from what precise statistics I know not—computed that, acre for acre, the food-productiveness of the banana is 133 times that of wheat; the unripe banana, before its starch is converted into sugar, is said to make excellent bread.

Considerations like these must in the end determine the range and avenues of commerce, perhaps the fate of continents. We must develop and guide Nature's latent energies; we must utilize her inmost workshops; we must call into commercial existence Central Africa and Brazil to redress the balance of Odessa and Chicago.

WILLIAM CROOKES.

(*To be concluded.*)

*VARIATIONS IN THE RATE OF AGRICULTURAL PRODUCTION AND ONE OF THEIR CAUSES.\**

THE twenty years ending with 1897 witnessed the harvesting in the United States of crops of corn, oats and rye, the yield per acre of which was from 50 to 60 per cent greater than the corresponding yield in certain other years of the same period; of crops of potatoes in which it was from 80 to 87 per cent greater than in other years of the period under consideration, and of crops of buckwheat in which it was from 80 to 130 per cent greater than in the case of certain other crops of buckwheat grown within this same period of twenty years. On the other hand, the highest annual yields per acre of wheat, cotton, hay, barley and tobacco were only 50, 39, 39, 36 and 23 per cent, respectively, higher than the lowest. This remarkable non-uniformity of fluctuation has suggested to the author of this paper the operation of some law not hitherto generally recognized, and the examination of the statistics of a large number of crops for each separate state during a period of twenty years shows that, entirely independently of whether the average yield per acre be high or low, the nearer the approach to the region to which a product is indigenous the more uniform will be the rate of production from year to year, and the further the departure from

such region the greater the liability to fluctuation.

For the purpose of this abstract, four products only need be considered: oats, barley, cotton and corn. The period covered is twenty years, 1878-97, and the comparison is based in each case—not upon the two extreme deviations, but on the means of the three highest and the three lowest yields per acre in the twenty-year period, the figures given representing the per cent of the deviation of these means from the mean of the entire period.

In the case of oats in 12 of the most northerly states of the Union (the Transition zone\* of the Merriam Life Zone Map) the deviation from the twenty-year average was only 34.23 per cent, only 2 states exceeding 40 per cent; in the Upper Austral (from New Jersey, Delaware and Maryland to Kansas and Nebraska) the deviation was 53.95 per cent, only one state having less than 40 per cent, and in the Lower Austral (from Virginia, the Carolinas and Georgia to Texas and Arkansas) it was 62.78 per cent, no state falling below 50 per cent. In the case of barley the deviation in the Transition zone was 37.7 per cent, in the Upper Austral 59.5 per cent, and in the Lower Austral 69.9 per cent.

On the other hand, in the case of corn and cotton it is with the extension of their cultivation northward that the range of fluctuation in the average rate of production is found to increase. In the case of cotton this variation was 25.1 per cent of the average yield per acre in Alabama, 26.3 per cent in Georgia, 35 per cent in Mississippi, 37.9 per cent in South Carolina, 40.4 per cent in Louisiana, 41.3 per cent in North Carolina, 42 per cent in Arkansas, 53 per cent in Texas, † 54 per cent in Vir-

\*The transcontinental belt in which Boreal and Austral elements overlap.

†The somewhat wide fluctuation in Texas is due to the extension of cotton planting into regions of uncertain rainfall.

\* Abstract of paper read before Section I—Social and Economic Science—of the American Association for the Advancement of Science, August, 1898.



ginia, 55.5 per cent in Florida,\* and 75.3 per cent in Tennessee.

Corn does not exhibit the same regularity of progression, owing (1) to the large acreage in the semi-arid portions of Texas, Kansas and Nebraska, where the frequent deficiency of moisture is a disturbing element; (2) to the extent to which special varieties have been adapted to local conditions to meet a want that no other crop can satisfactorily supply, and (3) to the extreme care with which this greatly esteemed product is cultivated in certain sections where its growth is precarious.† Still, the variation in the Upper Austral zone, excluding Kansas and Nebraska,‡ is 49.69 per cent, against 38.46 per cent in the Lower Austral, exclusive of Texas;‡ and if, for the reasons above stated, that of the most northerly tier of states, excluding Maine and Rhode Island,‡ is only 44.57 per cent, it is a significant fact that there is not a state in this belt with as small a variation as Alabama or Florida, and that there is but one that will compare favorably with Georgia, Mississippi, Louisiana or Tennessee.

Investigations show that this law of diminishing constancy is entirely independent of whether the average yield per acre is high or low, and that there is no general correspondence between its operation and the annual variation in the rainfall. The non-uniformity in the fluctuations of various products is attributed by the author to the

\*Not altogether reliable, owing to the non-determinable proportions of the upland and sea-island varieties.

† Although corn is essentially a tropical plant, the highest average yields per acre in this country are those of the New England States. While the high cultivation to which this is due has a steadying effect upon the rate of production from year to year, that rate of production is by no means so uniform as in the States bordering on the Gulf of Mexico, Texas excepted.

‡ The reasons for these exclusions are fully stated in the paper from which this brief abstract is taken.

different proportions of such products grown at a greater or less distance from the natural habitat.

JOHN HYDE.

U. S. DEPARTMENT OF AGRICULTURE.

ON THE REAPPEARANCE OF THE TILE-FISH.  
(*LOPHOLATILUS CHAMELEONTICEPS*.)

DURING March and April, 1882, the presence on the surface of the ocean of large numbers of dead tile-fish gave rise to considerable discussion in scientific journals, and frequent allusions have since been made in text-books, and elsewhere, to this phenomenon as illustrating the elimination of a species in recent times by purely natural agents. The reappearance of the fish in abundance in its original locality is, therefore, of considerable biological interest.

The history of the discovery, the 'extinction' and reappearance is as follows:

In May, 1879, Captain Kirby, of Gloucester, caught a great number of tile-fish off the southern coast of Nantucket, in water about 150 fathoms in depth. Specimens were sent to Washington and the species was described by Goode and Bean in the 'Proceedings of the U. S. National Museum' for that year. In July, Captain Dempsey, also of Gloucester, found several specimens in practically the same locality.

In 1880 Professor Baird sent the 'Mary Potter' to search for the fish, but the expedition, on account of uncommonly severe weather, was not successful. The 'Fish Hawk,' however, while exploring along the continental plateau, caught several specimens.

In 1881 the 'Fish Hawk,' continuing deep-sea work along the southern shore of New England, caught a large number, and Professor Baird felt confident that he was about to establish a new industry.

In March and April, 1882, vessels entering New York and other Atlantic ports reported that they had passed through

countless numbers of dead fish while crossing the northern edge of the Gulf Stream. Investigation proved that these were tile-fish, and that they appeared on the surface of the water for an extent of 170 miles in length and 25 miles in width. A conservative estimate, made by Captain J. W. Collins, placed their number at upwards of 1,438,720,000. Allowing ten pounds to each fish, there would be 288 pounds of fish for every man, woman and child then in the United States. In September, Professor Baird chartered the 'Josie Reeves' and sent her to the tile-fish grounds, that he might ascertain to what extent the species had been depleted; but the vessel returned without having found a single individual.

In 1883 the 'Albatross' made further search, but without success.

In 1884 the 'Albatross' made a more careful investigation, but again without success.

In 1885 the same vessel searched from Newfoundland to the Gulf of Mexico without discovering the least trace of the Tile-fish, though *Munida*, a species of Crustacean upon which the fish was known to have fed, was found in abundance.

In 1886, 1887, 1888, 1889, 1890 and 1891 nothing new was learned.

In 1892 Commissioner McDonâld fitted out the 'Grampus,' and on August 5th trawls were set on the old tile-fish ground. No fish were taken. On the 6th the trawls were set again, and one specimen weighing seven pounds was brought to the surface. This was the first specimen that had been seen since the mortality of 1882, ten years before. The 'Grampus' continued her work, and in about two weeks caught a second specimen which weighed thirteen pounds. On September 17th one specimen was caught, and on September 18th three specimens were taken. No more were caught until October 8th, when two were found

off the Delaware coast. Thus, in 1892, a search of two months yielded only eight specimens.

In 1893 the 'Grampus' resumed the search throughout the months of July, August and September and caught scattering specimens.

During 1894, 1895 and 1896 no additional information relative to the fish was secured.

On February 8, 1897, the Schooner 'Mabel Kenniston,' of Gloucester, was overtaken by a gale on George's Bank and blown 120 miles toward the southwest. After the gale, trawls were set in sixty-five fathoms of water, and thirty tile-fish were caught. These weighed from six to fifteen pounds each. They were landed at Gloucester on February 16th.

On August 12th, of the present year, the 'Grampus' left Woods Holl with a small party of scientific men, and sailed to a point about seventy miles south of No Man's Land. At the first set of the trawl, eight beautiful tile-fish were taken. The boat, insufficiently equipped with lines and bait, at once returned to the 'Station.' New trawls were purchased and on August 30th, ice and bait having been taken on at Newport, she again sailed south. The following morning, when the boat was only sixty miles from Block Island, the trawls were set. The first haul yielded seven fish; the second, forty-seven, and the third, nineteen. On the following day seventy-eight fish were taken, many of them of large size, and the vessel, now bearing 1,000 pounds, headed for Montauk Point, where the fish were given to the soldiers at Camp Wikoff.

When one considers that the trawls were short, provided with only a few hooks and tended by only one dory, it would seem that the fish are sufficiently abundant for an ordinarily equipped fishing-smack, with its miles of trawls, to secure a full fare in a very short time.

The tile-fish, since the mortality of 1882,

has been taken only along the edge of the continental plateau, in water near the one-hundred-fathom line, from points south of No Man's Land, Block Island and the eastern portion of Long Island. The 'range' of the species, as at present determined, is restricted to a tract of the sea bottom about one hundred and fifty miles in length, and ten to fifteen miles in width. The 'stations,' however, are few, and further investigation may result in a considerable extension of the range. The fish that have been caught during the past summer differ in respect to size from those that were caught before the mortality; for, while many are large, weighing fully twenty pounds, there are also many small immature individuals which often weigh but a pound or two. This percentage of immature fish would seem to indicate that the present environmental conditions are favorable, and that the species has become re-established.

H. C. BUMFUS,

*Director of Biological Laboratory.*

U. S. F. C. STATION, WOODS HOLL.

NOTE—The Grampus again visited the tile-fish grounds the latter part of September, returning to Woods Holl on October 2d, with over two hundred and three fish, weighing upwards of 3,000 pounds. This last catch was made between the meridians of 69 and 70 west longitude, a tract that has not heretofore been known to be occupied by the fish, and indicates an eastern extension of the range of about twenty-five miles.—H. C. B.

#### SERIATION CURVES OF THE CEPHALIC INDEX.

As a contributor to the discussion of the problems of 'type' and 'variation,' few sciences can offer a more comprehensive data for analysis than physical anthropology. Especially during the last ten years the number of observations available, based upon the study of European populations, has become very large. As late as 1885

the most considerable cranial series which Topinard\* could muster were those of Ranke for the Bavarians and of Broca for the Parisians respectively. These, numbering one thousand each, were at that time considered extraordinarily comprehensive. Yet, since the development of the younger school of anthropologists, whose leading principle has been to confine their measurements to the most simple alone, but to extend the number of individuals to a maximum, series of far greater range are possible. Interest in cephalic rather than cranial measurements, the living specimens being limited in number only by the endurance of the observer, has contributed greatly to this result. An analysis of a few seriation curves based upon such observations is not without importance even outside the limits of those interested in physical anthropology alone. Methods and principles are involved which apply to every branch of physical science, from astronomy to psychology.†

There is another imperative reason for calling attention to the significance of these seriation curves of cephalic observations. They are a most conclusive refutation of the statement, which reappears from time to time among those who do not consider the statistical aspects of physical anthropology, that the cephalic index measuring the proportions of the head is devoid of ethnic significance. Confused by the phenomena of individual variation, these critics lose sight of the value, when properly

\* *Éléments d' anthropologie*, pp. 387 *et seq.*

† The best technical discussion of such curves among anthropologists will be found in Goldstein, 1883; Stieda, 1883; Ammon, 1893 and 1896c; Livi, 1895 and 1896a, pp. 22 *et seq.* Dr. Boas has contributed excellent material, based upon the American Indians for the most part. Full titles of all these papers will be found in our Bibliography of the Anthropology and Ethnology of Europe; which, after more than a year of preparation, is shortly to be issued as a special bulletin by the public library of the city of Boston.



treated, of an ethnic criterion which is acknowledged by all the leading authorities of Europe to be of the utmost value. Still another objection to the use of the cephalic index as a racial criterion, even from some of its best friends, seems to be answered by the study of such curves. It is maintained that the cephalic index is not an objective reality, but merely a relation of the length of the head to its breadth. This is, indeed,

would be absurd to maintain it. Surely it is the *relativity* in length of the leg bones compared with spinal column. If such a relation, then, of the length of the head to its breadth be not a fit subject for detailed analysis our curves certainly belie it.

Seriation curves drawn for the cephalic index are entirely similar to the more familiar ones based upon observations of stature.\* The same principles underlie

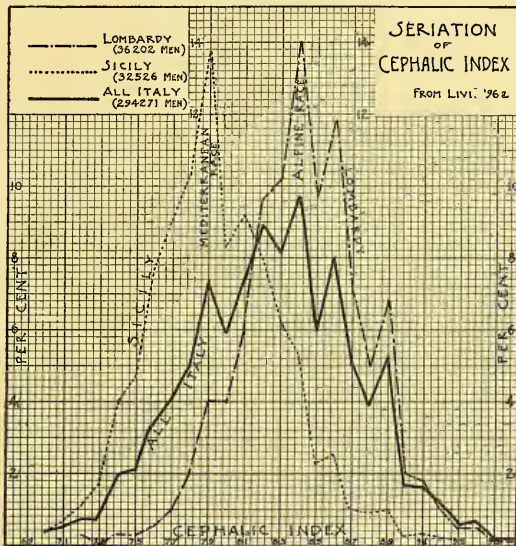

FIG. 1.

true. Yet how about nearly every other standard of comparison instituted either in anthropology or zoology? Is the long arm of the negro, compared with his length of trunk, according to Baxter and Gould, any the less characteristic because it is a *relation*? How do we measure the peculiarities in posterior extremities of the kangaroo or the rabbit? By their absolute length? It

them in each case. In the first of our diagrams it will be noted that we have to do with a very large number of individuals. It illustrates the difference in contour be-

\* These we have analyzed with diagrams in *Popular Science Monthly*, LI., 1897, p. 197 *et seq.* A special discussion of the significance of 'type' as distinct from 'race' will appear also in the *Jour. Anth. Inst.*, London, for November, 1898.

tween a curve drawn for a relatively simple population and one in which several distinct types are coexistent. The narrowness and height of the pyramids for the two extremes of Italy culminating at indexes of 79 and 84 respectively, are notable.\* The two regions are severally quite homogeneous in respect of the head-form of their population; for the apex of such curves rarely exceeds the limit of fourteen per cent. reached

clusion of each differently characterized population. It will be observed, however, that even this curve for a highly complex people preserves vestiges, in its minor apexes, of the constituent types of which it is compounded. Thus its main body culminates at the broadened head-form of the Alpine race; but a lesser apex on the left-hand side coincides with the cephalic index of the Mediterranean racial type, that

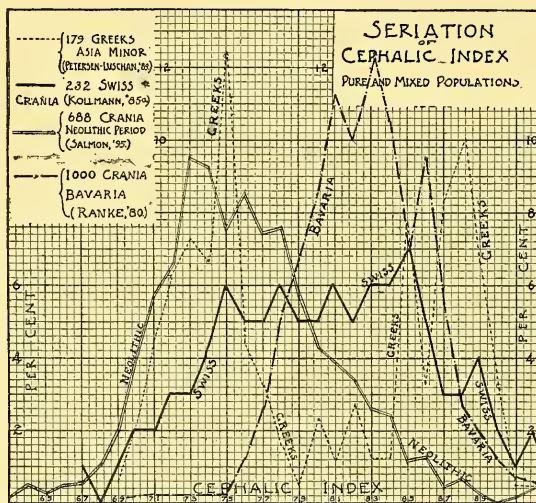

FIG. 2.

NOTE.—These curves are not strictly comparable with one another in detail; since they are based upon the differing systems of measurement of the French and German schools. Direct comparisons of cranial and cephalic index curves are also impossible. The form in all cases is, however, the same.

in these instances. The curve for all Italy, on the other hand, is the resultant of compounding such seriations as these for each district of the country. It becomes progressively lower and broader with the in-

\* Livi's maps of the distribution of these types in Italy are reproduced in our article on that country, in *Popular Science Monthly*, LI., 1897, p. 721 *et seq.*

which entirely dominated in the simple curve for Sicily alone.

The second diagram contains examples of a number of erratic curves. The Swiss one represents a stage of physical heterogeneity far more pronounced than that of all Italy, which we have just analyzed. Or rather, more truly, it is the product of an inter-

mixture upon terms of entire equality of a number of types of head-form. In Italy, as we have seen, the broader head-form so far outweighed the Mediterranean one that a single culminating point of maximum frequency still remained with a lesser one corresponding to the minority partner. In this second diagram Bavaria represents about the same condition as all Italy, with, however, the proportions of the two constituent types reversed. For ; being north of the Alps the culminating apex of greatest frequency lies toward the longer-headed side of the curve. Therein does the dolichocephaly of the Tentic race make itself manifest.

Compared with these curves for Italy and Bavaria, the Swiss seriation is seen to be devoid of any real apex at all. It represents a population in no wise possessed of distinct individuality so far as cephalic index is concerned. Broad and long heads are about equally common. This corresponds, of course, to the geographical probabilities for two reasons : inasmuch as Switzerland not only lies at the center of the continent; but, also, owing to its rugged surface comprises all extremes of isolation and intermixture within its borders. A stage of heterogeneity absolutely unparalleled seems to be indicated by still another of our curves, that drawn for the Greeks of Asia Minor. It culminates at the most widely separated cephalic indexes, viz., 75 and 88 respectively, known in the human species. The lower index corresponds to the primitive long-headed Greek stock ; the other is probably a result of intermixture with Turks, Armenians and others. Or, perhaps, it is nearer the truth to say that the only bond of unity in the entire series is that of language ; in other words, that the broad-headed apex represents Turks, Armenians and others, still physically true to their original pattern, yet who have chanced to adopt the speech of the Greeks. Here

again is the heterogeneous ethnic composition of eastern Europe fully exemplified by a seriation curve of cephalic index.

In conclusion, we may call attention to the following seriation curve based upon observations taken by Messrs. Fiske and Melliush upon nearly five hundred students

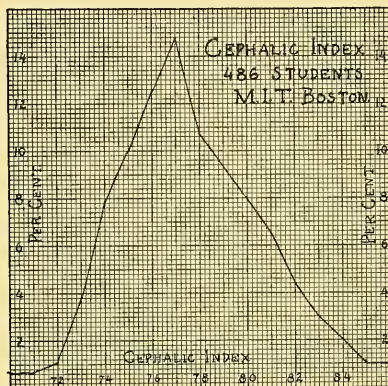

FIG. 3.

at the Massachusetts Institute of Technology. Its simplicity, points to a remarkable homogeneity of physical type, so far as the proportions of the head are concerned. This would seem to be at variance with our notions of the composition of our American population. Yet it should be observed, that this series is one based upon a selected class ; selected, in that it comprises those possessed of intellectual ability sufficient to enable them to withstand the pressure of Institute examinations. It appears that this purity of type, culminating at a cephalic index of about seventy-seven, corresponds quite closely to other series taken among peoples of Anglo-Saxon descent, especially in the English universities by Venn and others. From one end of the British Isles\* to the other a uniformity in

\*Vide our map in *Popular Science Monthly*, LII.,



this respect is apparent, which leaves little ground for expecting a heterogeneity in America. The broad-headed Alpine race of Central Europe, seems to have been so far excluded from the British Isles as to leave a population quite uniform in its cephalic proportions. A 'type' of head-form certainly transmissible not only from one population to its successor, but over seas as well, seems to be indicated.

WILLIAM Z. RIPLEY.

MASSACHUSETTS INSTITUTE OF TECHNOLOGY.

*THE INTERNATIONAL CONFERENCE ON  
TERRESTRIAL MAGNETISM.\**

THIS was the second occasion the British Association provided the means for a meeting of the scientists engaged in the study and development of our knowledge of terrestrial magnetism, the first magnetic congress having been held at Cambridge as far back as 1845. On the present occasion the Conference was of an international character, thanks to the cordial cooperation between the British Association and the International Meteorological Association, with which latter the Magnetic Conference for the present remains affiliated. It was at the International Meteorological Conference, held at Paris in 1896, that a 'Permanent Committee for Magnetism and Atmospheric Electricity' was appointed; it consisted of eight members with power to add to their number. The British Association allowed the Conference to organize under its President, Professor A. W. Rücker, M.A., D.Sc., as a branch of Section A (Mathematics and Physics), and undertook the expense of sending out the necessary notices to print the papers of the Conference in the report, and with great

1897, p. 148. Beddoe is best on this subject. Dr. West is the only other American observer studying the school children in Worcester, Mass.

\*Held at the Bristol Meeting of the British Association for the Advancement of Science, September 7-14, 1898.

liberality extended to the foreign delegates of the Conference all the privileges of foreign members of the Association. The Bristol Conference, under its President, Professor A. W. Rücker, was attended by Dr. A. Schuster, of England, and the following foreign members:

Dr. M. Eschenhagen, of Potsdam.  
Professor S. Lemström, of Helsingfors.  
Professor T. Liznar, of Vienna.  
Professor E. Mascart, of Paris.  
Ch. Moureaux, of Paris.  
Professor L. Palazzo, of Rome.  
Gen. M. Rykatchew, of St. Petersburg.  
Dr. A. Schmidt, of Gotha.  
C. A. Sebott, of Washington.

Besides these members various physicists and magnetists were present and took part in the deliberations.

In view of the fact that the United States Coast and Geodetic Survey has been largely engaged in the investigation and study of terrestrial magnetism in this country as forming part of its regular duty, inasmuch as the issue of its maritime charts demands the fullest information procurable, the Superintendent of the Survey proposed sending a delegate to the Bristol International Meeting to take part in the Conference. After approval by the Honorable Secretary of the Treasury instructions were issued by the Superintendent, Dr. H. S. Pritchett, in which he remarks: "The Conference having for its object the advancement of our knowledge in terrestrial magnetism, through communications and intercourse of those interested, you are expected to assist in these deliberations and make such suggestions as seem most appropriate, with a view of increasing our knowledge of the distribution of magnetism over the whole globe and in particular for the region covered by the United States."

The meetings, of which there were ordinarily two a day, one public, the other for consultation and discussion, were held at the University College and in connection

with Section A at the Museum. The Conference was opened with an address by its President giving a short historical review of the present organization, and setting forth as the object of the meeting the need of a closer association for guidance to future well directed and concerted effort in the field of terrestrial magnetism.

Among the questions submitted for deliberation and expressions of opinion were the following: In presenting monthly means of hourly tabulation of differential observations shall simple means only be given or shall they be accompanied by means derived from *undisturbed* values? In this question is involved the difficulty of recognizing a 'disturbed' observation, that is, of fixing a limit separating normal from apparently abnormal values. The discussion respecting the desirability of publishing, besides the usual values for declination, dip and horizontal intensity, at least for the months of January and July, the components of the magnetic force towards the north, the west and the vertical, involved also the the question of uniformity in notation as advocated by Professor F. Bigelow, *i. e.*, whether right or left-handed rotation respecting the axes would be preferable and whether the potential of the magnetic force should be regarded as affected with a positive or a negative sign.

A discussion was had respecting the relative value of long and short magnets. The principal work of the Conference, however, centered in the wider question involving magnetic observatories, their present unsatisfactory distribution over the globe and their inadequacy as regards numbers. It is here that the United States is in a condition to take a most important step in the advancement of knowledge by establishing and maintaining a well equipped magnetic observatory either on Oahu or one of the other Hawaiian Islands. This position is unique, being central to a vast unexplored

or magnetically unknown region and well adapted for the special study of the modifications which it is supposed the diurnal and secular variations may undergo in consequence of a surrounding ocean as contrasted with a continental surface. The destructive effect of electric tramways or trolley lines, when passing within a fraction of a mile or even within several miles of a magnetic observatory installed with sensitive self-registering instruments, was commented on and pointed out as an evil specially to be provided against in any new magnetic establishment. In considering the selection of positions for new observatories, attention was given to their greater need in the southern than in the northern hemisphere, aiming necessarily at as regular a distribution of all establishments as practicable.

Of special papers brought before the Conference may be mentioned: 'An account of the late Professor John Couch Adams' determination of the Gaussian magnetic constants,' by Professor W. Grylls Adams. 'Sur le mouvement diurne du pôle nord d'une barre magnétique suspendu par le centre de gravité,' par. J. B. Capello. 'On the influence of altitude above the sea on the elements of terrestrial magnetism,' by Dr Van Ryckevorsel and Dr. W. Van Bemmelen. 'On the interpretation of earth current observations,' by Arthur Schuster, F.R.S. 'On magnetic observations in the Azores,' by Albert, Prince of Monaco. 'On a simple method of obtaining the expression of the magnetic potential of the earth in a series of spherical harmonics,' by Arthur Schuster, F.R.S. 'Report of Professor von Bezold and General Rykatchew on the establishment of temporary magnetic observations in certain localities, especially in tropical countries. 'On the relations between the variations in the earth currents, the electric currents from the atmosphere and the

magnetic perturbations, by Selim Lemström. 'On the construction of magnets of constant intensity under changes of temperature,' by J. E. Ashworth. 'Antrag auf Massnahmen zur systematischen Erforschung der Secularvariationen der erdmagnetischen Elemente,' von Dr. Ad. Schmidt in Gotha. 'On magnetic observatories at Funafuti,' by Captain Creak. 'Some remarks on the construction of magnetic observatories,' by Dr. Snellen.

In joint discussion with Section A there was read a report of the committee on comparing and reducing magnetic observations, and in joint discussion with Sections A and G on the magnetic and electrolytic actions of electrical railways. Communications on this subject were made by C. A. Schott, Professor A. W. Rücker, Drs. von Eschenhagen and von Bezold, W. H. Preece, Signor Palazzo and Professor Fleming.

The results of the deliberations of the Conference were embodied in the report to be made to the International Meteorological Conference at its next meeting, and publication may be looked for by that organization and in part in the Proceedings of the Bristol Meeting. It is conceded by those who took an active part in the deliberations that this, the first international magnetic conference, has been most satisfactory in its results, and it is hoped that its fruits will show that the labor spent at Bristol was well directed.

Too much praise cannot be bestowed upon the effective manner in which the sessions of the Conference were presided over, which in no small degree contributed to the success of the meeting, nor will the members ever forget the cordiality of reception and generous hospitality extended to them by their President, the British Association and the Chamber of Commerce of the city of Bristol.

C. A. SCHOTT.

WASHINGTON, D. C., October 7, 1898.

*THE TENTH ANNUAL MEETING OF THE ASSOCIATION OF ECONOMIC ENTOMOLOGISTS, BOSTON, MASS., AUGUST 19 AND 20, 1898.*

THE Association was convened in the lecture hall of the building of the Society of Natural History, corner of Berkeley and Boylston Streets, and was attended by some 25 active members and a number of entomologists and other zoologists not members of the Association.

The following new active members were elected: Edward M. Ehrhorn, Mountain View, Cal., Horticultural Commissioner of Santa Clara County. W. M. Scott, Atlanta, Ga., State Entomologist. W. F. Fiske, Durham, N. H., Assistant Entomologist. J. L. Phillips, Blacksburg, Va., Assistant Entomologist. H. T. Fernald, Harrisburg, Pa., State Zoologist. E. Dwight Sanderson and Franklin Sherman, Jr., College Station, Md., Assistant Entomologists. A. L. Quaintance, State Entomologist, Florida Experiment Station. E. D. Ball, Assistant Entomologist, Colorado Experiment Station. F. H. Mosher, of the Gipsy Moth Commission.

The following new foreign members were also elected: V. Vermorel, Director of the Station of Viticulture and Vegetable Pathology at Ville France, France. Chas. T. Musson, F.L.S., F.R.H.S., Lecturer on Botany and Vegetable Pathology and Zoology, etc., at Hawkesbury Agricultural College, Richmond, New South Wales.

The reading of papers was preceded by the annual address of President Osborn, on 'The Duty of Economic Entomology.'

The following papers were presented in the order given during the four regular sessions of the Association, Friday and Saturday, August 19th and 20th. The papers in full, with the discussions which they elicited, will be published as a bulletin by the Division of Entomology of the U. S. Department of Agriculture, as has been the custom in former years.



## LIST OF PAPERS.

- 'Two Beneficial Insects introduced from Europe,'  
L. O. Howard.
- 'Notes on some of the Insects of the Year in the State of New York,'.....E. P. Felt.
- 'The Brown-tail Moth (*Euproctis chrysoorrhæa*),'  
C. H. Fernald.
- 'The Distribution of the San José or Pernicious Scale in New Jersey,'.....J. B. Smith.
- 'Hydrocyanic Acid Gas as a Remedy for the San José Scale and other Insects,'....W. G. Johnson.
- 'Some Notes on Observations in West Virginia,'  
A. D. Hopkins.
- 'Notes on House Flies and Mosquitoes,'  
L. O. Howard.
- '*Pulvinaria acericola* (W. and R.) and *P. innumerabilis* Rathv.'.....L. O. Howard.
- 'An Abnormal Coccinellid,'.....A. F. Burgess.
- 'Notes on some Massachusetts Coccidæ,'  
R. A. Cooley.
- 'Notes on Spruce Bark Beetles,'  
C. M. Weed and W. F. Fiske.
- 'A Review of the Work in Economic Entomology in Pennsylvania,'.....H. T. Fernald.
- 'Experiments with Insecticides for the Gypsy Moth and Brown-tail Moth,'.....A. H. Kirkland.
- 'Notes on the Life History of the Woolly Aphis of Apple (*Schizoneura lanigera* Hanssman),'  
W. B. Alwood.
- 'On the Life History of *Protoparce carolina*,'  
W. B. Alwood.
- 'Notes on the Fertilization of Muskmelons by Insects,'.....F. W. Rane.
- 'Notes on Tent Caterpillars,'.....C. M. Weed.
- 'Recent Work of the Gypsy Moth Committee,'  
E. H. Forbush.
- 'The San José Scale in Connecticut' (read by title only).....W. E. Britton.
- 'Insect Injury to Broom Corn' (read by title only),  
F. H. Chittenden.
- 'Entomological Ethics' (read by title only),  
T. D. A. Cockerell.
- 'Vernacular Names of Insects' (read by title only),  
E. W. Doran.
- 'A New Squash Bug' (read by title only),  
F. H. Chittenden.
- 'Notes from Maryland on the Principal Injurious Insects of the Year' (read by title only),  
W. G. Johnson.
- 'On the Life History of *Thrips tritici*' (read by title only),.....A. L. Quaintance.
- 'Notes on Insecticides' (read by title only),  
C. L. Marlatt.
- 'Insects of the Year in Ohio' (read by title only),  
F. M. Webster and C. W. Mally.

An hour was given on Saturday morning to a joint meeting with the Society for the Promotion of Agricultural Science when the papers presented before this Society on entomological subjects were read.

By the courtesy of the Gypsy Moth Commission of the State Board of Agriculture, Massachusetts, an excursion was given to the members of the Association to the districts about Malden where work is being prosecuted against the gypsy moth, opportunity being afforded the members to make an examination of the methods of work followed and the results obtained.

The following officers were elected for the ensuing year: President, C. L. Marlatt; First Vice-President, Lawrence Bruner; Second Vice-President, C. P. Gillette, and Secretary-Treasurer, A. H. Kirkland.

In accordance with the established custom the next session will be held on the two week days preceding the general sessions of the American Association for the Advancement of Science, and at the place selected by the latter body.

C. L. MARLATT,  
Secretary.

## NOTES ON INORGANIC CHEMISTRY.

In a paper read before the Chemical Section of the British Association at the Bristol meeting Professor Ramsay describes more fully the isolation and properties of the new element neon. Eighteen liters of argon were liquefied and then fractionally distilled. After three fractionations the lightest fraction had a density of 9.76. This gas no longer liquefies at the temperature of liquid air boiling at 10 mm. and consists chiefly of neon with the admixture of small quantities of argon and nitrogen. Pure neon seems to have a density of 9.6, and, as the ratio between specific heat at constant pressure and constant volume is 1.655, the element is, like helium and argon, monatomic, and its atomic weight therefore 19.2,

following fluorin and preceding sodium in the periodic table. Its refractivity is low, being 0.3071 compared with air, that of helium being 0.1238 and that of argon 0.958. Its spectrum is characterized by brilliant lines in the red, the orange and the yellow, also two lines in the green.

In the last fractions of liquid argon Professor Ramsay finds three new gases, one of them not previously described. These are krypton, which had previously been obtained from liquid air and characterized by two very brilliant lines, one in the yellow and one in the green; metargon, which shows a spectrum closely resembling that of carbon monoxid, but characterized by its inertness, not being changed by sparking with oxygen in the presence of caustic potash; and a still heavier gas, not hitherto described, which Professor Ramsay calls xenon—the stranger. This gas possesses a much higher boiling point than the others and is easily separated, but is present in only minute quantity. Its spectrum is analogous to that of argon, but differs in the position of the lines. The quantity of neon present in the atmosphere is estimated as one part in 40,000, and that of the other gases at even less.

MOISSAN has described, in the *Comptes Rendus*, a hydrid of calcium of the formula  $\text{CaH}_2$ , formed by heating crystallized calcium in a stream of dry hydrogen. It is a hard, white crystalline body, stable in dry air, even at a red heat, but burning before the oxy-hydrogen flame. At ordinary temperatures it is not very reactive, but when heated reacts readily with most of the negative elements. It is a powerful reducing agent, decomposing cold water with great violence, with the formation of calcium hydroxide and liberation of hydrogen. In this hydrid the hydrogen thus seems to resemble the carbon in calcium carbid and the phosphorus in calcium phosphid.

How much need there is of a careful revision of much of our knowledge regarding inorganic compounds is well illustrated by two investigations in the last *Berichte*. Muthmann and Nagel, in studying the lower oxidation stage of molybdenum, show that the supposed monoxid  $\text{MoO}$  has no existence, but is really  $\text{Mo(OH)}_3$ . They also confirm Blomstrand's conjecture that the supposed dichlorid  $\text{MoCl}_2$  is in reality  $\text{Mo}_3\text{Cl}_6$ . They proved its formula by determining its molecular weight by the boiling-point method.

FROM the days of Berzelius the dark precipitate formed by alkaline stannous chlorid in a bismuth solution has been considered to be a monoxid of the formula  $\text{BiO}$ . Vanino and Treubert show conclusively that this precipitate is in reality metallic bismuth with more or less  $\text{Bi}_2\text{O}_3$ , and that  $\text{BiO}$  cannot be formed in the wet way.

ACCORDING to *Engineering* aluminum is being introduced into India as a substitute for copper and brass in the manufacture of cooking utensils. Professor Chatterton, of the Madras University, commenced experiments with the metal-working classes of the School of Arts, and a little later a small factory was equipped whose output is now over a ton a month. The vessels have been very favorably received, which is very remarkable considering the conservatism of India. It is necessary, however, that the vessels should be the exact counterparts of the copper and brass vessels previously in use, and they must be hand-made and not spun. Efforts are being made to establish similar factories elsewhere than at Madras.

THREE papers by Professor Vèzes have recently appeared in the *Procès Verbaux*, of the Société des Sciences Physiques et Naturelles de Bordeaux, which should be noted. The first is on the double oxalates of platinum and palladium. The platoxalates have been long known, but obtained by a rather

laborious process, which gives rise to beautiful crystals with a coppery red sheen, and which are a very complex oxalate. Under certain circumstances the pale yellow crystals of the normal platoxalate are obtained. Vèzes finds that when the chlorplatinite of potassium is heated with neutral potassium oxalate in a neutral solution the platoxalate of potassium is very readily formed with no admixture of more complex compounds. An analogous reaction produces the normal palladoxalates.

A PRACTICAL application of this reaction is made in Vèzes' second paper. With the exception of chlorplatinic acid, potassium chlorplatinite is doubtless the most used platinum compound, being the starting point for all the platinum-ammonium bases. Up to this time no method of its manufacture can be considered satisfactory, especially upon a commercial scale. The reduction of chlorplatinic acid by sulfur dioxide must be very carefully carried out or complex sulfoplatinites result; heating platinic chloride till two atoms of chlorine are given off is difficult to accomplish with anything like quantitative precision; and the reduction with cuprous chloride gives a product very difficult to free from all traces of copper. Vèzes suggests the use of oxalic acid in neutral solution. If potassium chlorplatinate (and most platinum residues are of this compound) is boiled with the theoretical quantity—37%—of neutral potassium oxalate in water insufficient to dissolve the platinum salt, in the course of several hours it is quantitatively converted into the chlorplatinite, most of which crystallizes out on cooling and all of which may be recovered by adding alcohol. This operation can be successfully carried out on a large scale. Since the publication of Vèzes' article the method has been tested in the Washington and Lee University laboratory, and I can bear testimony to its success

and its great advantage over the earlier methods.

VÈZES' third paper is on the criticism of Dumas on Stas' determination of the atomic mass of nitrogen. Dumas showed the presence of oxygen in silver which has been fused, and calculated that the figure of Stas should be reduced from 14.044 to 14.002, a variation greater than that of experimental error. Vèzes has gone over the calculations, using Stas' original figures and introducing the correction for occluded oxygen, and shows that the original figure of Stas would be reduced from 14.044 only to 14.040, a change far less than the limit of experimental error. Another testimony is thus borne to the wonderfully accurate work of the Belgian chemist.

J. L. H.

#### BOTANICAL NOTES.

##### A STUDY OF TOADSTOOLS.

MR. C. G. LLOYD, of Cincinnati, an enthusiastic student of the larger fungi has recently brought out an illustrated paper ('A Compilation of the Volvæ of the United States') which deals with the species of two genera of toadstools, viz.: *Amanita*, with thirty-eight species, and *Volvaria*, with twelve. Nine 'half tone' reproductions of photographs illustrate the paper. These toadstools are characterized by the young plants being enclosed in a thick membrane, called a volva, and having a soft and fleshy structure, with entire, thin, sharp gills, which do not deliquesce. Some of the species are edible, but so many are poisonous that the author says: "My advice is, Don't eat any Amanitas, and you will make no mistake."

##### A SOUTHERN FERN FAR FROM HOME.

FOR some time rumors of the occurrence of the Southern Maidenhair Fern (*Adiantum capillus-veneris*) in the Black Hills of southwestern South Dakota have drifted to the Botanical Department of the University of



Nebraska. Their occurrence so far north seemed so unlikely that at first little attention was given to these rumors. At length specimens of this fern were received which were said to have grown wild at Cascade, in the edge of the Black Hills. A personal investigation was the only thing which could settle the matter, for it still seemed very likely that some mistake had been made, and that the specimens received had come from some more southern station. Accordingly I visited the locality August 24, 1898, in company with Dr. F. E. Clements, and we were astonished to find this fern in great abundance along the banks of Cascade Creek. This stream is a couple of metres wide and twenty to thirty centimetres deep, and is fed by several large springs of warm water, having a temperature of about 26° Cent. We very carefully examined the locality and satisfied ourselves that this fern is indigenous and that it has not been introduced by human agency. Since this discovery I have seen specimens of the same species collected at Cascade in 1892, and a fragment collected in 1890 at Hot Springs, ten miles distant, along the banks of Fall Creek, another warm stream. Mrs. Alice M. Crary, a keen observer who has lived many years in the Black Hills, assures me that they grew abundantly along Fall Creek at Hot Springs, 'before that place was settled.' All this tends to corroborate our conclusion that these ferns were not transplanted by human agency, and that we have here a curious problem in the distribution of a species.

#### THE FUNCTION OF BLOOM.

As is well known to botanists but not so well known to the general public, the white powdery coating on some leaves and fruits is waxy in nature and is called 'bloom' in technical works on Botany. Its function has received some attention, Mr. Darwin having made it the object of some studies

in his later years. In a recent number of the *Laboratory Bulletin*, of Oberlin College, along with papers by the lamented Professor H. L. Jones, is a short one by his assistant, Miss Roberta Reynolds, giving the results of a series of experiments which show that when the bloom is removed from the epidermis the transpiration of water is greatly increased. Thus in case of *Agave utahensis* the loss was about two and a-half times as much from the leaf which was without bloom as from that with the bloom. With *Echeveria peacockii* it was two and a-third times as much; with *Agave verschaffelti* one and four-tenths; *Agave americana* about two and a-half; an undetermined *Agave*, two times as much; two unnamed species of *Cotyledon*, about one and one-third. It was observed, also, that on damp days the difference between the leaves was less than on dry days; so, too, there was less difference in the case of young leaves than when old ones were used.

#### A TINY PINE TREE.

LAST summer I climbed Green Mountain, near Boulder, Colorado, and found growing from a crevice in one of the rocks at the summit a small tree of *Pinus albicaulis* Engelm., about thirteen centimeters high and five millimeters in diameter. It was unbranched, and bore a single, terminal tuft of leaves. And yet this tiny tree, when carefully examined, was found to have twenty-five distinct annual rings. I know of no other case of natural dwarfing carried to such an extreme, and, therefore, place this one on record.

CHARLES E. BESSEY.

THE UNIVERSITY OF NEBRASKA.

#### CURRENT NOTES ON ANTHROPOLOGY.

BOTANICAL KNOWLEDGE OF THE ANCIENT AZTECS.

STUDENTS of ancient Mexico are acquainted with the work of Dr. Hernandez, who was sent by Philip II. to study the plants and

minerals of New Spain. His 'Natural History' was printed in 1651 and is a storehouse of the knowledge of the Aztecs on that subject. In describing a plant he always gave its native name and how employed by the Indians.

In the *Anales del Instituto Medico Nacional*, Tom. II., No. VI., 1898, is an article by Dr. F. Altamirano, in which he endeavors to identify the plants mentioned by Hernandez and give their modern botanical names. He quotes fifty-one, assigning most of them to genera and species, and adds the modern uses to which they are applied. The article forms a useful appendix to Hernandez.

#### SEXUAL DIMORPHISM IN MAN.

In a pamphlet of about forty pages Prof. Dr. Giuseppe Marina sums up the results of his measurements of 22,755 adults, Italians, Slavs and Germans. His studies tend to diminish the value of the skull-form as a criterion and to cast doubt on the 'criminal type.' But the most novel of his results relate to the relation of the sexual characteristics in general to the pelvic diameters. He formulates the law that in proportion as the pelvic index in the one sex approaches that of the other, this similarity will be correlated to a cranial form and capacity, and to a number of traits, physical and mental, which belong to the other sex. Feminilism in the male, for example, is displayed by the length of the iliac crests, the shortness of the inferior extremities, a wider pubic angle, ampler cotyloid cavities, greater distance of the umbilicus from the pubis, development of the mamme, etc. Dr. Marina points out that these traits are racial, sexual dimorphism being much more marked in some than in other stocks. The point is of wide-reaching significance. (*Studi Anatomici sugli Adulti*. Torino, 1897. Fratelli Bocca.)

#### HEREDITY ; A CONTRAST.

In the *Revue Scientifique* for April last Dr. Cesare Lombroso, in an able discussion of the relative influence of heredity and environment, announced the conclusion that "the influence of environment is potent enough to annihilate all ethnic traits."

At the meeting of the German Anthropological Society in August of this year Professor Kollmann, of Basel, in an address on the same subject, stated the dictum of science to be that "the influence of heredity is far stronger than that of environment. The ethnic traits are immortal and persist, though the peoples who bear them may disappear from history." (*Globus*, Aug. 27, 1898.)

These are two of the most eminent authorities among European anthropologists. As the traditional circus man said: "You pays your money and you takes your choice."

D. G. BRINTON.

UNIVERSITY OF PENNSYLVANIA.

#### SCIENTIFIC NOTES AND NEWS.

THE CONFERENCE ON AN INTERNATIONAL CATALOGUE OF SCIENTIFIC LITERATURE.

THE Second Conference on an International Catalogue of Scientific Literature began its sessions in the rooms of the Royal Society on October 12th. On the preceding evening the President and Council of the Society gave an 'At Home' to meet the delegates, and a dinner followed on the evening of the 12th. The foreign delegates in attendance at the opening of the Conference were: France, Professor Darboux and M. Deniker; Austria, Professor Weiss and Professor Boltzmann; Hungary, Dr. A. Heller and Dr. Theodore Duka; Holland, Professor Korteweg; Belgium, M. Descamps, M. Otlet and M. Lafontaine; Switzerland, Dr. J. Henri Graf and Dr. Jean Bernoulli; Japan, Professor Einosuke Yamaguchi; Norway, Dr. J. Brunchorst; Sweden, Dr. E. W. Dahlgren; United States, Dr. Cyrus Adler. Men of science throughout the world are greatly interested in

the plan of an international catalogue of scientific literature, and it is to be hoped that an opportunity will be given for full discussion and careful consideration before the final arrangements are made. We regret to state that no such opportunity has been hitherto offered. SCIENCE, as other scientific journals, was unable to secure satisfactory information regarding the first Conference at the time, though we were fortunate in being able to publish (Vol. VI., pp. 184-201) a year later an admirable account of the Proceedings, based upon official documents, by Dr. Cyrus Adler, the delegate from the United States to the present Conference. No similar accounts, so far as we are aware, have been given in other scientific journals, nor is this surprising, as the Proceedings of the last Conference were not distributed, only two copies, it is said, having been sent to America. Scarcely any mention has been made of the schedules of classification which have recently been drawn up, and which will doubtless be discussed by the present Conference. These schedules have apparently not been sent to scientific journals nor to men of science. The schedule on anthropology has, however, been severely criticised by Dr. Brinton (SCIENCE, p. 375). At the last Conference a decimal system of classification was practically rejected, but it appears that the Committee on Organization have adopted a new system of decimal classification, and it is by no means certain that this system is better than Dewey's. We find in the English press full accounts of the reception and dinner, but as yet nothing regarding the scientific proceedings of the Conference.

#### GENERAL.

PROFESSOR BOWDITCH, President of the American Society of Naturalists, called a meeting in Boston and gave a dinner to the Executive Committee on the 22d ult. Professor Dean was appointed a delegate to represent the New York Local Committee. The American Society of Naturalists and affiliated societies will, it will be remembered, meet in New York during the last week of the present year. We hope to be able to give full announcements regarding the meetings at an early date.

THE class of 1893 of Williams College has est-

ablished a prize of \$25 in memory of the late Franklin Story Conant, who, it will be remembered, sacrificed his life to scientific work in Jamaica. The money is to be used for a scholarship at the Woods Holl Marine Biological Laboratory.

THE Civil Service Commission announces that on December 6, 1898, the examination may be taken at any city in the United States where the Commission has a board of examiners, for the position of Chief of the Bureau of Statistics, Treasury Department, at a salary of \$3,000 per annum. The examination will consist of the subjects mentioned below, which will be weighted as follows :

Science of Statistics—	
(a) Topical,.....	10
(b) Textual,.....	5
Mathematics, .....	5
Literature of statistics, .....	10
Practical statisticism—	
(a) Tabulating, .....	5
(b) Analysis and graphics,.....	5
(c) Commercial statistics,.....	10
General and technical education, .....	20
Administration—	
(a) Positions held and experience,....	15
(b) Essay, .....	15
Total, .....	100

THE Commission also invites attention to the fact that no applications were filed for the examination scheduled to be held in New York September 21, 1898, for Assistant Engineer, first-class, in the custodian service in that city, at a salary of \$1,080 per annum, and that another examination is scheduled to be held on November 15, 1898.

WE learn from *Nature* that, by a decree dated August 30th last, the Belgian government has separated the astronomical from the meteorological service, each of these departments being placed under a responsible scientific director; while administrative duties, care of instruments, library, etc., are to be under the control of an inspector. The astronomical service is placed under M. C. Lagrange, and meteorology under M. A. Lancaster, each of whom will submit a report quarterly to the Minister of the Interior upon the work of his department.



THE Thompson-Yates Laboratory of the Liverpool University College was formally opened by Lord Lister on October 8th. We have already described the laboratories of pathology and physiology presented to Liverpool University College by Mr. Thompson-Yates, which, under Professors Boyce and Sherrington, are certain to make important contributions to science. Before the opening of the laboratories, Lord Lister was invested with the honorary doctorate of science of the Victoria University, and made an address. There was further a banquet given by the Lord Mayor, at which speeches were made by the Lord Mayor, Lord Lister, Earl Spencer, Mr. Edward Lawrence, Sir William Turner, Professor Foster, Principal Glazebrook, Professor Sherrington and Professor Virchow.

It is proposed to erect a suitable memorial to James Clerk Maxwell, in the parish church of Corssock, of which he was a trustee and elder. Subscriptions may be sent to the Rev. George Sturrock, The Manse, Corssock by Dalbeattie, N. B.

A MONUMENT to the memory of Sigismondo Boldoni, physician, poet and philosopher, has been erected in Milan, where he was born in 1597.

THERE will shortly be dedicated a monument to the physiologist Ernst von Fleischmarxow. It consists of a bust in profile by Emil Fuchs and will be unveiled with appropriate ceremonies.

BUSTS of General Champion de Nansouty and of M. Vaussenat, the engineer, founders of the National Meteorological Observatory on the Pic du Midi, have been recently unveiled. Addresses were made by M. Mascart and M. Bailaud, Directors of the Toulouse Observatory.

It is announced that Sir Andrew Noble will give to the Kew Observatory the installation needed to make direct comparisons with the gas thermometer. This has been hitherto lacking, although Kew is the British station for standardizing thermometers. The entire endowment of the Kew Observatory, it appears, is only £470 and the free use of a building. It is to be hoped that the government will follow the advice of their Committee on a National

Physical Laboratory, and provide the adequate endowment for a laboratory at Kew.

THE vacancy in the Assistant Directorship of Kew Gardens, says *Nature*, caused by the appointment of Mr. D. Morris as Commissioner of Agriculture for the West Indies, will not be filled. Mr. S. T. Dunn has been appointed Secretary to the Director. Upon the nomination of the Director, Mr. C. A. Barber has been appointed Government Botanist at Madras, in succession to the late Mr. M. A. Lawson.

MR. C. S. PARSONS has been appointed Director and Irrigation Engineer of the Arizona Agricultural Experiment Station.

THE British Astronomer Royal (Mr. W. H. M. Christie, C.B.) has been elected junior warden of the Clockmakers' Company, which received its charter in 1631 from King Charles I. The late Astronomer Royal (Sir George B. Airey) was also closely associated with the Clockmakers' Company.

WE regret to record the death of Professor Arzruni, mineralogist, in the Polytechnic Institute at Aix, and of the geologist de Windt, while on a scientific expedition to Lake Tanganyika.

THE 'Harben Lectures' in connection with the Institute of Public Health, London, will be delivered by Sir Richard Thorne Thorne, on November 2d, 9th and 16th. The subject will be 'The Administrative Control of Tuberculosis.'

SIR DOUGLAS GALTON, K.C.B., will give, on October 17th, an address introductory to the twenty-sixth course of lectures and practical demonstrations in sanitary science arranged by the Sanitary Institute of Great Britain for sanitary officers and students at the Parkes Museum.

THE third annual meeting of the New York State Science Teachers' Association will be held at the Teachers College, Columbia University, New York City, on December 29th and 30th. The President of the Association is this year Professor Charles W. Hargitt, of Syracuse University; the Secretary is Dr. Franklin W. Barrows, of the Buffalo High School (45 Park St., Buffalo, N. Y.), from whom information regard-

ing the important work of the Association may be obtained.

WE learn from *Nature* that the banquet of the Chemical Society to those of its past-Presidents who have completed fifty years' fellowship of the Society, which was postponed last June owing to the lamented death of the senior past-President, Lord Playfair, is now arranged to take place on Friday, November 11th, at the Hôtel Métropole. The past-Presidents who will then be entertained are: Sir J. H. Gilbert, F.R.S.; Sir Edward Frankland, F.R.S.; Professor Odling, F.R.S.; Sir F. A. Abel, Bart., F.R.S.; Dr. A. W. Williamson, F.R.S., and Dr. J. H. Gladstone, F.R.S.

FOREIGN scientific journals state that Professor P. Knuth, of Kiel, is starting this month on a scientific expedition round the world, extending over from eight to ten months. He proposes a considerable stay in Buitenzorg, Java, visiting India on his way, and afterwards China and Japan, Honolulu and North America. Professor K. Goebel, of Munich, is also starting, this autumn, on a botanical journey to Australia and New Zealand.

MR. N. R. HARRINGTON gave a lecture, on October 24th, at Columbia University on the Senff Zoological Expedition, reported in the last issue of this JOURNAL.

THE University of Pennsylvania and the Academy of National Sciences have received valuable collections of specimens from Alaska, secured near Point Barrow, as the result of a scientific expedition under the management of E. A. Mchenny, of Louisiana, fitted out and conducted by N. G. Buxton, of Ohio, and W. E. Snyder, of Wisconsin. The *Boston Transcript* states that there are nearly 13,000 specimens in all. The zoological, botanical and ornithological specimens, which constitute the largest part of the collection, have been disposed of to the Academy of Natural Sciences, while the ethnological and anthropological portion will enrich the already large collection in the Museum of Archæology and Paleontology at the University of Pennsylvania.

THE city of Bombay has provided for the establishment of a laboratory under the Directorship of Dr. Galeotti, professor of pathology in

Florence, for the preparation of Professor Lustig's curative serum for the plague.

THE California State Board of Health has appointed Dr. C. A. Ruggles, President of the Board, to visit the Hawaiian Islands, to learn the extent of the presence of leprosy and report measures to prevent its introduction into California. Since the annexation of Hawaii its inhabitants are free to come to the United States, and it is the intention of the Board of Health to prepare a report for submission to the Legislature which will suggest safeguards against the spread of leprosy in California.

THE following figures regarding the relative cost of the military and educational establishments of four leading nations deserve careful consideration at the present time:

	Army and Navy.	Education.
Great Britain . . .	£40,650,000	£10,140,000
Germany . . . . .	32,840,000	12,120,000
France . . . . .	36,570,000	7,920,000
United States . . .	16,700,000	36,890,000

In round numbers France spends seven times as much in preparation for war as in preparation for peace, Great Britain four times as much and Germany two and a-half times as much, whereas America has hitherto spent more than twice as much for education as for armaments. If the military expenditures of the United States must be increased, let the expenditures for education be increased in at least the same ratio.

DR. HERMANN NÖTHNAGEL, professor of pathology in the University of Vienna, has been carrying out in his laboratory experiments on the bacillus of the bubonic plague, which have resulted disastrously. The assistant in the laboratory, Dr. Barisch, contracted the plague and died. The physician, Dr. Müller, and the two nurses who attended him have also contracted the disease and Dr. Müller has died. The lectures at the pathological institute have been suspended, and all Dr. Nothnagel's assistants and attendants have been isolated. The government has appointed a committee, containing representatives of national and municipal bodies, to devise measures to prevent the spread of the plague.

IRVING W. FAY, professor of chemistry in the Brooklyn Polytechnic Institute, while show-

ing an experiment to his class, it is said, with liquid air and red phosphorus, met with an accident, through a violent explosion, which may cause the loss of his eyesight. One of the students was also injured.

An inquest has been held in London in regard to the cause of the death of Harold Frederick, the well-known novelist and newspaper writer, owing to the fact that he was attended in his illness by a 'Christian Scientist.' The physicians who had been dismissed testified that he had suffered from rheumatic fever and paralysis and declared their belief that he would have recovered with proper treatment. According to English law the 'Christian Scientist' may be prosecuted for manslaughter.

THE report of the principal chemist upon the work of the Inland Revenue Branch of the Government Laboratory of Great Britain for the year ended March 31, 1898, shows that the number of analyses and examinations made during the year amounted to 65,313, this being a slight increase over the previous year.

THE Navy Department is issuing to volunteers who passed examination for admission to the United States Navy during the late war with Spain, but who are not given commissions because of the early termination of the war, certificates stating the facts and the reason for their non-acceptance. The document, which is nicely got up, will be a helpful certificate for many of its recipients and a pleasant souvenir for all.

THE Museums and Lecture-rooms Syndicate, of Cambridge University, in their annual report for the past academical year, says the *London Times*, alludes to the loss the Science Schools sustained by the death of Professor Roy, the first professor of pathology. To his energy is due the establishment of one of the most successful of the departments connected with medical studies. He possessed the power of attracting workers to Cambridge, and many of his pupils now hold important posts, not only in Great Britain and the colonies, but also in the United States of America. The reports of the Woodwardian professor of geology, of the professor of botany, and of the Superintendent of the Museum of Zoology, draw at-

tention to the overcrowded state of their respective departments and the need, which is becoming increasingly urgent, for new and more spacious accommodation both for the students and the collections under their charge. The recently erected buildings for the department of mechanism have proved insufficient for the growth of the school, and the need for another lecture-room and more laboratory space has become pressing. The buildings devoted to medicine and surgery are not only in a bad state of repair, but are also inadequate and inconvenient. During the past year very considerable additions to the collections have been made. Numerous expeditions which have left Cambridge to prosecute researches in far-distant lands have returned, and the collections they have brought home are both valuable and extensive. Especial mention may be made of a series of lepidosiren and its embryos and a valuable collection of other specimens from South America, which have been presented to the Museum of Zoology by J. Graham Ker, B.A., Christ's College, and J. S. Budgett, Trinity College; of the large collections illustrating the fauna of the South Pacific coral reefs collected by J. Stanley Gardiner, M.A., Gonville and Caius College, during his recent visit in the coral-boring expedition to Funafuti, and presented by him to the same museum; and of the varied and valuable collections made by Dr. Willey (Balfour student) in New Britain and the neighboring islands. The collection of crania which Dr. Willey has presented to the Museum of Human Anatomy is mentioned by the professor, who also draws attention to the valuable donation of Egyptian skulls made by Professor Flinders Petrie. Part of the collections made by Dr. Haddon in Torres Straits in 1888-89 has been presented to the Museum of Zoology, which has been further enriched by a skeleton of the elephant seal presented by Sir W. L. Buller, K.C.M.G., and many other donations mentioned in the report of the Superintendent. The Rev. Professor Wiltshire has presented a very valuable and extensive collection of minerals to the Mineralogical Museum, and H. H. W. Pearson, B.A., Christ's College, has added to the Botanical Museum a collection of plants which he made during his recent journey to Ceylon.



## UNIVERSITY AND EDUCATIONAL NEWS.

In his opening lecture to the engineering students at Cambridge, on October 14th, Professor Ewing intimated that the crowded state of their lecture rooms and laboratories would soon be relieved. A gift of £5,000 had just been made for the addition of a new wing to the engineering laboratory in memory of the late Dr. John Hopkinson and of his son, John Gustave Hopkinson, who recently lost their lives in the Alps. Dr. Hopkinson's son was to have begun work at this time as a student of engineering at Cambridge. This gift was made by Mrs. Hopkinson jointly with her son Bertram and her surviving daughter.

THE litigation commenced by the heirs of the late Dr. Elizabeth Bates, who left a bequest of \$160,000 to the Michigan University, seems in a fair way to end in favor of that institution. It is reported that the contestants of the will have concluded to relinquish all claim to the personal property of the decedent, amounting to \$120,000, and the Court has ordered this amount to be turned over to the University authorities. This leaves only the remainder of the bequest, \$40,000, which is the subject of litigation.

MISS WHEELER has presented \$5,000 to the permanent library fund of Williams College, as a memorial to her father, who was a graduate of the College.

COMMEMORATION Day at Princeton University, which has been established since the sesquicentennial two years ago, was celebrated on October 22d, the chief event being an address by President D. C. Gilman, of Johns Hopkins University.

It is understood that Professor G. J. Brush, Director of the Sheffield Scientific School, will retire next January, after service as executive head of the School since 1872.

DR. B. MOORE, formerly instructor in physiology in University College Hospital, has been appointed professor of physiology in the Yale Medical School.

DR. ALBERT MATHEWS has been appointed assistant professor of physiology at Tufts College.

LUCIEN N. SULLIVAN, of the Sheffield Scientific School, and John C. Peck, of the Rose Polytechnic Institute, have been appointed instructors in mechanical engineering in Lehigh University.

THE chair of botany at Oberlin College, vacant by the death of Professor Herbert Jones, has been filled by the appointment of Frederick O. Grover. Mr. Grover was graduated from Dartmouth in 1890, and subsequently continued his studies at Harvard University.

THE faculty of the University of Vienna, says *The Philadelphia Medical Journal*, has nominated the following, in the order named, one of whom shall succeed the late Professor Stricker, professor of experimental pathology: Professor von Mering, of Halle; Professor Knoll, of Prague; Professor Klemensiewicz, of Gratz; Professor Lowit, of Innsbruck.

PROFESSOR BARTHOLOMEW PRICE, Master of Pembroke College, has resigned the Sedleian chair of natural philosophy at Oxford University on the completion of his eightieth year. Oxford University has suffered a more serious loss in the resignation of Professor Ray Lankester to accept the Directorship of the Natural History Museum. Oxford is not so strong in science that it can afford any loss, and it is to be hoped that chairs in physics and comparative anatomy may be filled by men of science who will exert an important influence in the much needed development of the University.

## DISCUSSION AND CORRESPONDENCE.

A RULE FOR FINDING THE DAY OF THE WEEK CORRESPONDING TO A GIVEN DATE.\*

'PERPETUAL' calendars that can be consulted with greater or less readiness are to be found in works on astronomy and in encyclopedias, but I have not found any published rule for the simple problem of determining mentally the day of the week without reference to a calendar or lengthy table. Therefore, I venture to submit the rule that I have devised for this purpose.

\* Read at the Fifth Summer Meeting of the American Mathematical Society.

To find the day of the week corresponding to a given date, add to the day of the month the index number of the month and the index number of the year, then subtract the largest multiple of seven that is less than the sum. The remainder will be the number of the day of the week.

The index numbers of the months are as follows:

January, 3 (in leap years, 2).  
 February, 6 (in leap years, 5).  
 March, 6.  
 April, 2.  
 May, 4.  
 June, 0.  
 July, 2.  
 August, 5.  
 September, 1.  
 October, 3.  
 November, 6.  
 December, 1.

To find the index number of the year, for any year from 1800 to 1899 inclusive, increase the excess of the year over 1800 by one-fourth of itself (discarding fractions) and subtract the largest multiple of seven contained in the sum. For dates in other centuries a multiple of 28 is added or subtracted so as to bring the year within the above limits, and, after finding the index number for the resulting year, one is likewise added or subtracted for each centesimal year not divisible by 400 that is passed over (or of which the beginning is passed over). If many years are to be passed over it is often convenient to use multiples of 112.

A few illustrations of the application of this rule are here given. To find the day of the week corresponding to August 20, 1898, we add the index numbers of the year, 3, and of the month, 5, to 20, and subtract 3 times 7. The remainder, 7, indicates that this is the seventh day of the week, or Saturday. If the index numbers of all the months and of a given year are known, it is ordinarily quicker to find the day of the week mentally than to consult a calendar of the given year. For July 4, 1776, we add 28 to 1776 and find the index number of 1804 to be 5; adding one for the year 1800 passed over gives 6, the index number of 1776; to which we add  $2 + 4$ ; subtracting 7 we have the remainder 5, indicating Thursday.

For December 25, 2046, we deduct 224 from the year and find the index number of 1822 to be 6. Deducting one for the year 1900 passed over (2000 is divisible by 400 and so is a leap year and requires no deduction), we find 5 as the index number of the year 2046. Adding  $1 + 25$  we find that Christmas of that year will come on Tuesday.

As this subject is so simple it would be unnecessary to give a deduction of the rule. But it may be noted that if the index numbers of the months are not remembered, that of one month may be found by adding the index number of the year to the day of the month (for any date for which the day of the week is known) and subtracting the sum from the day of the week increased by a multiple of seven. The index numbers of the remaining months may then be obtained in succession, as the index number of any month, except January, is equal to that of the preceding month increased by the number of days therein and diminished by a multiple of 7.

Dates given in old, or Julian, style should first be changed to new, or Gregorian, style. The Dominical letter of any year may be found by deducting the index number of the year from 5 or 12. Thus for 1898 we have  $5 - 3 = 2$ , indicating the second letter of the alphabet, or B, as the Dominical letter.

If in time it should be more convenient to calculate the index numbers of the years from the excess of the years over 1900 instead of 1800, that modification of the rule may be made if the index numbers of the months are increased by 5 or diminished by 2.

EDWARD L. STABLER.

BROOKLYN, N. Y.

#### AN APPLE CANKER.\*

LAST spring I began investigating the cause of the so-called apple canker. This disease attacks the bark of the larger limbs, where all stages of development may be seen from small sunken areas to the large cankers of many inches extent. In aggravated cases a portion of the wood is laid bare. The bark becomes swollen and rough in all directions from the

\* M. B. Waite, *Rural New Yorker*, February 5, 1898, p. 82.

wound, so that the diseased limbs become quite conspicuous. These wounds produce an effect similar to girdling, and where many limbs are attacked the effect on a tree is disastrous.

In preliminary work on the disease certain large dark-colored spores were continually found, but they were supposed to come from some saprophyte not worthy of attention. In cultures made from diseased bark this form, together with another, continually appeared. Finally both forms were separated and transferred to bean stems in test tubes. In the one case the familiar dark spores were produced, while in the other the sporophores of *Schizophyllum commune* were formed.

Inoculations were made with both forms on apple seedlings in the nursery and on limbs of an apple tree. In two weeks' time it was found that in every case inoculations made from the fungus with dark spores had taken effect, while the *Schizophyllum* had in no instance made any growth. The wounds made in the bark of check trees healed over at once. More inoculations were now made and the results have been the same. At this date, October 9th, several of the seedlings are nearly girdled with wounds three to four inches in length. The inoculations on the limbs of apple trees have made an equally satisfactory growth, laying bare the wood and producing the dead, sunken areas of bark characteristic of the disease.

When it was found that the fungus with the dark spores was parasitic, diligent search was made for the spores on diseased bark, but none were to be found. This was in the fore part of July. Further search throughout the summer failed to reveal any of the spores.

On September 11th Mr. F. C. Stewart, Botanist of this Station, examined the test-tube cultures and at once noted the strong resemblance of the dark spores to those of the black rot of the apple, *Sphaeropsis malorum*, Peck. Mature apples were at once inoculated with material from the test tubes. In twenty-four hours decay had begun around points of inoculation, and in 16 days pycnidia and mature spores of *Sphaeropsis* were found on all inoculated apples. The check apples which were punctured but not inoculated remained sound. Further search for the dark spores on diseased

bark revealed pycnidia just beneath the epidermis containing the mature brown spores and immature ones still attached. All characters were identical with *Sphaeropsis* on the fruit. These same pycnidia were subsequently found on bark of the nursery stock and apple-tree limbs where the inoculations were made. Pure cultures of *Sphaeropsis malorum* from apples make the same growth on bean stems and bear fruit in exactly the same manner as the first cultures from which the inoculations were made.

While it seems reasonably certain that this canker of the apple is caused by a well-known fungus in a hitherto unrecognized rôle, the result of a set of experiments now under way is awaited to complete the chain of evidence. Seedlings placed in the greenhouse have been inoculated with pure cultures of *Sphaeropsis malorum* taken from affected apples. If these inoculations produce the so-called canker the identity of the disease will be established.

W. PADDOCK.

#### WAMPUM BELTS.

TO THE EDITOR OF SCIENCE: Thanks for the kind notice of my article on wampum by my esteemed friend, Dr. Brinton. I wish, however, to correct the word 'acknowledges,' as it seems to imply that I believe in the early use of council wampum, a belief against which I have argued for years. In a very mild way I stated that 'it is very doubtful whether wampum belts were used before the coming of the whites as necessary or ordinary parts of Indian councils.' I thought quill belts might have been used, as in the Onondaga tradition of Hiawatha. Because of the great rarity of shell beads on early sites in New York and Canada, I thought 'a mistake has been made regarding Cartier's account of Hochelagan beads in 1535.' But one shell bead has been found at Hochelaga, and there is a corresponding rarity on early Mohawk and Onondaga sites. Quoting another I said, "My own experience is the same, Pre-historic Onondaga sites yield few shell articles or none at all."

I have examined as many wampum belts and as much council wampum as most men, and my conclusion is precisely that of Dr. Brinton.



"All known to me are later than the discovery, and none have been found in ancient burials." He is fully sustained by facts in his historic doubt 'that wampum belts were made by the prehistoric Indians.' When the New York bulletins on archæology reach the use of shell articles, I hope, should I prepare that paper, to show this in detail. The material is in hand, but not yet arranged. Meanwhile it is certain that the early interior inhabitants of New York knew little of shell beads at all.

W. M. BEAUCHAMP.

#### SCIENTIFIC LITERATURE.

*Practical Plant Physiology; an Introduction to Original Research for Students and Teachers of Natural Science, Medicine, Agriculture and Forestry.* By DR. W. DETMER, Professor of Botany in the University of Jena. Translated from the second German edition by S. A. MOOR, M. A. (Camb.), F. L. S., Principal of the Girasia College, Gondal, Kathiawad, India. With one hundred and eighty-four illustrations. New York, The Macmillan Co.; London, Swan, Sonnenschein & Co. 1898. 8vo. Pp. xix + 555. Price, \$3.00.

The laboratory method of study finds variable application in the several departments of botany, but in none is it so typically and profitably serviceable as in the domain of physiology. The strong chemical and physical bias which pervades the subject permits almost every vital operation of the plant to be brought under control by chemical or physical methods. As changes and movements in plants are usually slow, the greatest delicacy of method and apparatus is often required to secure intelligible results. In consequence of these facts the laboratory part of instruction in vegetable physiology is destined to become varied and extensive, and to take form slowly.

It is to the credit of Dr. Detmer, of Jena, that he presented to the botanical public the first manual in any language for the guidance of the student in vegetable physiology. It was a work of over 350 pages, issued in 1888, and although at the time it was said by some of his colleagues not adequately to represent the current state of the science, yet time has shown that for an initial work it was exceptionally

well achieved, and that to produce a more representative and serviceable volume has been a task that few have since attempted. After a decade the work has passed into a second edition, so much changed and amplified as to almost constitute it a new book, but retaining the characteristics that have made its predecessor so acceptable to many instructors and students.

Although a French edition appeared in 1890, no English version has been prepared until the present time. That it has now been made available to the English-speaking student will be welcome information to many instructors who have heretofore made less use of the work than desired. It is gratifying to find that the translation has been well done, and that it adequately expresses not only the facts of the volume, but the sense of the author's personal interest, which lends a charm to both German and English versions. An unusual feature of the translation is the rendering of the whole volume without addition or alteration. This is, in some respects, a good method, as one receives from the hands of the translator the unsophisticated result of the author's labor, but when it extends to the translation of an appendix giving the places in Germany where apparatus may be obtained, it seems as if the substitution of names of firms in the countries where the book is expected to be used would have been a meritorious deviation.

The outline of the work embraces the food of plants, the molecular forces in plants, metabolic processes, movements of growth and movements of irritation. It contains but little matter not truly a part of physiology, according to strict interpretation of the term. The two hundred experiments, or, more properly speaking, studies, into which the work is divided, cover a great variety of topics and are drawn largely from the memoirs of the most distinguished investigators. But it is to the labors of the author in testing, modifying and adapting the experiments to the condition of pedagogical requirement that give them much of their value in this connection.

It would be easy to find fault with some parts of the work. The first experiments given in the book, those of water cultures, are likely to prove discouraging to the beginner, as they re-

quire much attention, extend over a long period, and are often failures owing to conditions that require experience to foresee and control. Some of the experiments require technical knowledge and skill not to be expected of the average pupil who presents himself for this class of work, as, for example, where the directions say to determine the nitrogen by Kjeldahl's method or by Stutzer's method, and with a reference to a chemical treatise proceeds to the next step in the experiment as if the quantitative determination of nitrogen were an everyday affair in a botanical laboratory.

But these defects, or limitations, may be dismissed as not impairing the usefulness of the work, if it be understood at the outset that the book is not adapted to seriatim study by the classes of any institution, unless it be those of the author, at least not those in any American institution. But a sufficient wealth of material is provided so that the instructor may select what best suits his purpose, and under this eclectic system the work must commend itself as highly satisfactory and serviceable.

J. C. ARTHUR.

*Quantitative Chemical Analysis by Electrolysis.*

By DR. ALEXANDER CLASSEN, Privy-Councillor, Professor of electro-chemistry and inorganic chemistry in the Royal School of Technology at Aachen; in cooperation with DR. WALTER LÖB, lecturer on electro-chemistry in the Royal School of Technology at Aachen. Authorized translation, third English from the revised and greatly enlarged fourth German edition, by WILLIAM HALE HERRICK, A.M., formerly professor of chemistry in Iowa College and in the Pennsylvania State College, and BERTRAM B. BOLTWOOD, PH.D., instructor in analytical chemistry in the Sheffield Scientific School of Yale University. New York, John Wiley & Sons; London, Chapman & Hall. 1898. Pp. 301.

The earlier editions of Classen's book are so well known that it is only necessary to call attention to the difference between this and preceding editions. The book is greatly improved by the introductory chapter on the theory of electro-chemistry. Says the author in his preface: "The present edition, revised with the assist-

ance of Dr. Löb, differs from the previous editions in that the introduction has been augmented by the insertion of a section devoted to theory. This was made the more necessary since the investigations of recent years have been chiefly devoted to the explanation of reactions in solutions and the determination of electrical magnitudes." This chapter deals with the theory of electrolytic dissociation, the laws of Faraday and Ohm, the significance of tension, current strength, and resistance, the theory of electrolytic precipitation.

The remainder of the 'general part' of the book takes up the methods of measuring the strength of the current, the measurement of current tension, the sources of current, including primary and secondary batteries, and physical means of producing the current, such as electro-magnetic machines and thermopiles. Given the means of producing, regulating and measuring the current, it remains to apply the methods to the precipitation and separation of the metals. These are described in the 'special part' of the book, and it is safe to say that most of the best electro-chemical methods are included here. The appendix contains a number of practical examples of electro-chemical analysis.

This book comes from one of the leading authorities, and is generally recognized as a standard in the field which it covers.

H. C. J.

*Introduction to Electro-chemical Experiments.* By DR. FELIX OETTEL. Translated by EDGAR F. SMITH. Philadelphia, P. Blakiston, Son & Co. 1897. Pp. 143.

*Practical Exercises in Electro-chemistry.* By DR. FELIX OETTEL. Translated by EDGAR F. SMITH. Philadelphia, P. Blakiston, Son & Co. 1897. Pp. 92.

The first of these two little books by Oettel deals with the conditions necessary for electro-chemical experiments, such as sources of the current, methods of measuring the current, including different forms of the voltameter and galvanometer, and methods of measuring pressure. The arrangement of apparatus and electrolyte in carrying out an experiment is then taken up. This is followed by a brief discus-

sion of polarization currents, Faraday's law, ion transference, preliminary experiments, etc.; and the concluding chapter discusses the construction and calibration of instruments, such as the tangent galvanometer and those used for measuring pressure and regulating resistance. Tables of electro-chemical equivalents of the more important elements, of thermo-chemical data, and of wire resistance, are appended.

The second book, as its title implies, is in part of a more practical character. The first forty pages are given again to a discussion of instruments, but the remainder is devoted to a discussion of simple electro-chemical experiments, such as electrolysis of hydrochloric acid with and without a diaphragm; electrolysis of dilute sulphuric acid, or sodium hydroxide, with a diaphragm; formation of persulphuric acid by the electrolysis of sulphuric acid; precipitation of copper under different conditions; precipitation of magnesium from a fused salt of the metal; the number of processes involved being sufficient to give some idea of electro-chemical operations.

The final chapter, on 'Organic Electrolysis,' was written by Professor Elbs and is one of the most interesting chapters in the book. In a very few experiments it gives some idea of the application of electrolysis to organic chemistry, an idea which is, however, greatly enlarged by such a work as the third volume of Peters' 'Angewandte Elektrochemie.'

The translation by Professor Smith is especially welcome, not simply because of his skill in such work, but since it comes from the leading authority in practical electro-chemistry in America.

H. C. J.

#### SCIENTIFIC JOURNALS.

*The Journal of Geology*, May-June, 1893: The number opens with 'A Symposium on the Classification and Nomenclature of Geologic Time-Divisions,' a contribution that is based on a series of fourteen questions that had been submitted to the geologists mentioned below. The questions involve a discussion of the extent to which subdivision should be pursued in the time and physical scales, and of the number of

geological periods (as the word period was used by the Berlin Congress) which it is desirable to adopt. Considerable difference of opinion is developed, so much so as to make the average teacher impatient with this continual tinkering with words. Opinions are expressed by Joseph Le Conte, G. K. Gilbert, W. B. Clarke, S. W. Williston, Bailey Willis, C. R. Keyes and Samuel Calvin. 'Probable Stratigraphical Equivalents of the Coal Measures of Arkansas,' by C. R. Keyes. The author cites the great thickness of the Arkansas Coal Measures as compared with those of Iowa and Missouri, *i. e.*, 2,400 feet as against 500-600, and strongly opposes the ordinary conception of the Ozark island of Carboniferous and later time. He emphasizes the evidence that land conditions followed the deposition of the St. Louis limestone and preceded the formation of the Iowa and Missouri Coal Measures. He explains the greater thickness of the Arkansas measures by their continuity of deposition without regard to this change on the north. A paper 'On the Origin of certain Siliceous Rocks' is presented in two parts. The first, by O. A. Derby, contains 'Notes on Arkansas Novaculite,' and gives the results of an investigation of the novaculite by crushing it to slimes without destroying the larger included grains of secondary quartz. The slimes were then studied with the microscope, and the author reached the conclusion that an origin by replacement of cherty limestone has great claims to confidence. J. C. Branner, in the second part, comments on these results and systematically reviews the explanations that have been advanced for the siliceous rocks. He adds a few notes on those in California. 'A Study of Some Examples of Rock Variation,' by J. M. Clements, deals with an interesting series of eruptives at Crystal Falls, Mich., which follow the Upper Huronian and precede the Potsdam. The series consists of quartz-diorite, hornblende-gabbro, bronzite-norite and peridotite, and is described in detail with analyses. The hornblende-gabbro was first in time; then came the norite and peridotite, and, last of all, the diorite with transitions into granite. Under the 'Studies for Students' a good brief review of the development and geological relations of the fishes is given by E.



C. Case. It is meant to be the first of a series on vertebrates. Editorials and reviews close the number.

*The Journal of Geology*, July-August, 1898: 'The Ulterior Basis of Time Divisions and the Classification of Geologic History:' T. C. Chamberlin. Apropos of the symposium in the last number the author seeks some world-wide parallel, geologic phenomena which may afford a suitable basis for geological classification. He urges the possible validity of great geologic disturbances, which he argues are in the nature of general shortening of all the radii of the earth, but of comparatively greater shortening of those under the sea bottoms. The effects on the regions of sedimentation and continental encroachment on the sea are indicated. 'The Post-glacial Connecticut at Turner's Falls, Mass.:' M. S. W. Jefferson. The paper describes the interesting rearrangements of drainage lines along the Connecticut river near the famous 'bird-track' quarries. The agency of ice is invoked to explain the two abandoned channels, with their former waterfalls and pot-holes, which now are ponds. 'The Variations of Glaciers, III.:' H. F. Reid. Reports during 1897 to the International Committee indicate a marked retreat of glaciers in general, with one or two small advances in Scandinavia. 'Notes on the Kalamazoo and other Old Glacial Outlets in Southern Michigan:' C. H. Gordou. The paper deals with several abandoned river channels and their relations to the modern streams. The region lies along the general latitude of Port Huron and extends from Lake Huron to Lake Michigan. The paper is accompanied by a map whose excessive reduction taxes the eyesight beyond reason. 'Notes on some Igneous, Metamorphic and Sedimentary Rocks of the Coast Ranges of California:' H. W. Turner. This valuable contribution takes up first the metabasalts and diabases of the Coast Ranges. More or less altered rocks are traced back to original, eruptive diabases, although in some instances they had been regarded previously by geologists as metamorphosed sediments, *i. e.*, pseudodiabases. Observations on serpentines are also given. The author next discusses the Francis-

can, or Golden Gate formation. This contains the interesting blue amphibole (glaucophane) schists that are generally familiar to petrographers. The age of the formation is thought to be older than that of the Knoxville, *i. e.*, to be Jurassic. An argument is made against the necessary origin of the blue schists by contact metamorphism. The San Pablo formation is next taken up and its stratigraphical position is discussed on the basis of fossils. Comparisons are drawn with the auriferous gravels. Under the 'Studies for Students,' E. C. Case continues his brief review of the development and geological relations of the vertebrates, and treats of the Amphibia and Reptilia. Editorial remarks, a number of summaries of pre-Cambrian literature and reviews close the number.

---

#### NEW BOOKS.

- The Tides, and Kindred Phenomena in the Solar System.* GEORGE HOWARD DARWIN. Boston and New York, Houghton, Mifflin & Co. 1898. Pp. xviii+378.
- A Manual of Chemical Analysis.* G. S. NEWTH. New York and London, Longmans, Green & Co. 1898. Pp. xii+462.
- Manual of Determinative Mineralogy with an Introduction on Blowpipe Analysis.* GEORGE J. BRUSH. Revised by SAMUEL L. PENFIELD. Fifteenth Edition. New York, John Wiley & Sons; London, Chapman & Hall, Ltd. 1898. Pp. x+312.
- Elementary Zoology.* FRANK E. BEDDARD. New York and London, Longmans, Green & Co. 1898. Pp. vi+208.
- Lecture Notes on the Theory of Electrical Measurements.* WILLIAM A. ANTHONY. New York, John Wiley & Sons; London, Chapman & Hall, Ltd. 1898. Pp. vi+90. \$1.00.
- Human Immortality; Two Supposed Objections to the Doctrine.* WILLIAM JAMES. Boston and New York, Houghton, Mifflin & Co. 1898. Pp. 70. \$1.00.
- The Copper Dam Process for Piers; Practical Examples from Actual Work.* CHARLES EVAN FOWLER, Bridge Engineer. New York, John Wiley & Sons. 1898. 8vo. Pp. xv+159. \$2.50.

# SCIENCE

EDITORIAL COMMITTEE: S. NEWCOMB, Mathematics; R. S. WOODWARD, Mechanics; E. C. PICKERING Astronomy; T. C. MENDENHALL, Physics; R. H. THURSTON, Engineering; IRA REMSEN, Chemistry; J. LE CONTE, Geology; W. M. DAVIS, Physiography; O. C. MARSH, Paleontology; W. K. BROOKS, C. HART MERRIAM, Zoology; S. H. SCUDDER, Entomology; C. E. BESSEY, N. L. BRITTON, Botany; HENRY F. OSBORN, General Biology; C. S. MINOT, Embryology, Histology; H. P. BOWDITCH, Physiology; J. S. BILLINGS, Hygiene; J. MCKEEN CATTELL, Psychology; DANIEL G. BRINTON, J. W. POWELL, Anthropology.

FRIDAY, NOVEMBER 4, 1898.

ADDRESS OF THE PRESIDENT BEFORE THE  
BRITISH ASSOCIATION FOR THE AD-  
VANCEMENT OF SCIENCE,  
BRISTOL, 1898.

## II.

### CONTENTS:

<i>Address of the President before the British Association for the Advancement of Science, Bristol, 1898</i> (II.): SIR WILLIAM CROOKES.....	601
<i>Recent Advances in Malacology</i> : WM. H. DALL.....	612
<i>An Instance of Local Temperature Control of the Distribution of Mammals</i> : GERIT S. MILLER, JR.....	615
<i>The Annual Inspection of the Pribilof Seal Rookeries</i> : DR. C. H. TOWNSEND.....	618
<i>The Natural History Museums of British Columbia</i> : HARLAN I. SMITH.....	619
<i>Zoological Bibliography and Publication</i> .....	621
<i>Astronomical Notes</i> :—	
<i>Section A at the Boston Meeting, A. A. A. S.; The Asteroid DQ.; The Andromeda Nebula</i> : PROFESSOR WINSLOW UPTON .....	623
<i>Zoological Notes</i> :—	
<i>Another Specimen of Notornis; Zoological Nomenclature</i> : F. A. LUCAS .....	625
<i>Current Notes on Anthropology</i> :—	
<i>Antiquities of Costa Rica: The Borgian Codex; A newly-published Aztec Document</i> : PROFESSOR D. G. BRINTON.....	626
<i>Scientific Notes and News</i> :—	
<i>The Naturalists and Affiliated Societies; The German Naturforscher und Aerzte</i> .....	627
<i>University and Educational News</i> .....	633
<i>Discussion and Correspondence</i> :—	
<i>Measurements of Precision: X. Life-zones in New Mexico</i> : PROFESSOR T. D. A. COCKERELL, DR. C. HART MERRIAM.....	634
<i>Scientific Literature</i> :—	
<i>Pelcers' Angewandte Elektrochemie</i> : H. C. J. HOWARD. <i>New York Section of the American Chemical Society</i> : DR. DURAND WOODMAN. <i>Engelmann Botanical Club</i> : HERMANN VON SCHRENK .....	638
<i>Scientific Journals</i> .....	638
<i>Societies and Academies</i> :—	
<i>Entomological Society of Washington</i> : DR. L. O. HOWARD. <i>New York Section of the American Chemical Society</i> : DR. DURAND WOODMAN. <i>Engelmann Botanical Club</i> : HERMANN VON SCHRENK .....	638
<i>New Books</i> .....	640

HAVING kept you for the last half hour rigorously chained to earth, disclosing dreary possibilities, it will be a relief to soar to the heights of pure science and to discuss a point or two touching its latest achievements and aspirations. The low temperature researches which bring such renown to Professor Dewar and to his laboratory in the Royal Institution have been crowned during the present year by the conquest of one of Nature's most defiant strongholds. On the 10th of last May Professor Dewar wrote to me these simple but victorious words: "This evening I have succeeded in liquefying both hydrogen and helium. The second stage of low-temperature work has begun." Static hydrogen boils at a temperature of 238° C. at ordinary pressure, and at 250° C. in a vacuum, thus enabling us to get within 23° of absolute zero. The density of liquid hydrogen is only one-fourteenth that of water, yet in spite of such a low density it collects well, drops easily and has a well-defined meniscus. With proper isolation it will be as easy to manipulate liquid hydrogen as liquid air.

The investigation of the properties of bodies brought near the absolute zero of temperature is certain to give results of extraordinary importance. Already platinum

resistance thermometers are becoming useless, as the temperature of boiling hydrogen is but a few degrees from the point where the resistance of platinum would be practically nothing or the conductivity infinite.

Several years ago I pondered on the constitution of matter in what I ventured to call the fourth state. I endeavored to probe the tormenting mystery of the atom. What is the atom? Is a single atom in space solid, liquid or gaseous? Each of these states involve ideas which can only pertain to vast collections of atoms. Whether, like Newton, we try to visualize an atom, as a hard, spherical body, or, with Boscovitch and Faraday, to regard it as a center of force, or accept the vortex atom theory of Lord Kelvin, an isolated atom is an unknown entity difficult to conceive. The properties of matter—solid, liquid, gaseous—are due to molecules in a state of motion.

Therefore, matter as we know it involves essentially a mode of motion; and the atom itself—intangible, invisible and inconceivable—is its material basis, and may, indeed, be styled the only true *matter*. The space involved in the motions of atoms has no more pretension to be called matter than the sphere of influence of a body of riflemen—the sphere filled with flying leaden missiles—has to be called lead. Since what we call matter essentially involves a mode of motion, and since at the temperature of absolute zero all atomic motions would stop, it follows that matter as we know it would at that paralyzing temperature probably entirely change its properties. Although a discussion of the ultimate absolute properties of matter is purely speculative, it can hardly be barren, considering that in our laboratories we are now within moderate distance of the absolute zero of temperature.

I have dwelt on the value and importance of nitrogen, but I must not omit to bring to your notice those little known and curiously related elements which during the past

twelve months have been discovered and partly described by Professor Ramsay and Dr. Travers. For many years my own work has been among what I may call the waste heaps of the mineral elements. Professor Ramsay is dealing with vagrant atoms of an astral nature. During the course of the present year he has announced the existence of no fewer than three new gases—krypton, neon and metargon. Whether these gases, chiefly known by their spectra, are true, unalterable elements, or whether they are compounded of other known or unknown bodies, has yet to be proved. Fellow workers freely pay tribute to the painstaking zeal with which Professor Ramsay has conducted a difficult research, and to the philosophic subtlety brought to bear on his investigations. But, like most discoverers, he has not escaped the flail of severe criticism.

There is still another claimant for celestial honors. Professor Nasini tells us he has discovered, in some volcanic gases at Pozzuoli, that hypothetical element, coronium, supposed to cause the bright line 5316.9 in the spectrum of the sun's corona. Analogy points to its being lighter and more diffusible than hydrogen, and a study of its properties cannot fail to yield striking results. Still awaiting discovery by the fortunate spectroscopist are the unknown celestial elements, aurorium, with a characteristic line at 5570.7, and nebulum, having two bright lines at 5007.05 and 4959.02.

The fundamental discovery by Hertz, of the electro-magnetic waves predicted more than thirty years ago by Clerk Maxwell, seems likely to develop in the direction of a practical application which excites keen interest—I mean the application to electric signalling across moderate distances without connecting wires. The feasibility of this method of signalling has been demonstrated by several experimenters at more than one meeting of the British Association,



though most elaborately and with many optical refinements by Oliver Lodge at the Oxford meeting in 1894. But not until Signor Marconi induced the British post-office and foreign governments to try large scale experiments did wireless signalling become generally and popularly known or practically developed as a special kind of telegraphy. Its feasibility depends on the discovery of a singularly sensitive detector for Hertz waves—a detector whose sensitiveness in some cases seems almost to compare with that of the eye itself. The fact noticed by Oliver Lodge in 1889, that an infinitesimal metallic gap subjected to an electric jerk became conducting, so as to complete an electric circuit, was rediscovered soon afterwards in a more tangible and definite form and applied to the detection of Hertz waves by M. E. Branly. Oliver Lodge then continued the work, and produced the *vacuum filing-tube* coherers with automatic tapper-back, which are of acknowledged practical service. It is this varying continuity of contact under the influence of extremely feeble electric stimulus alternating with mechanical tremor which, in combination with the mode of producing the waves revealed by Hertz, constitutes the essential and fundamental feature of 'wireless telegraphy.' There is a curious and widely-spread misapprehension about coherers, to the effect that to make a coherer work the wave must fall upon it. Oliver Lodge has disproved this fallacy. Let the wave fall on a suitable receiver, such as a metallic wire, or, better still, on an arrangement of metal wings resembling a Hertz sender, and the waves set up oscillating currents which may be led by wires (enclosed in metal pipes) to the coherer. The coherer acts apparently by a species of end-impact of the oscillatory current, and does not need to be attacked in the flank by the waves themselves. This interesting method of signalling—already developing

in Marconi's hands into a successful practical system which inevitably will be largely used in lighthouse and marine work—presents more analogy to optical signals by flash-light than to what is usually understood as electric telegraphy, notwithstanding the fact that an ordinary Morse instrument at one end responds to the movements of a key at the other, or, as arranged by Alexander Muirhead, a siphon recorder responds to an automatic transmitter at about the rate of slow cable telegraphy. But although no apparent optical apparatus is employed, it remains true that the impulse travels from sender to receiver by essentially the same process as that which enables a flash of magnesium powder to excite a distant eye.

The phenomenon discovered by Zeeman, that a source of radiation is affected by a strong magnetic field in such a way that light of one refrangibility becomes divided usually into three components, two of which are displaced by diffraction analysis on either side of the mean position and are oppositely polarized to the third or residual constituent, has been examined by many observers in all countries. The phenomenon has been subjected to photography with conspicuously successful results by Professor T. Preston in Dublin and by Professor Michelson and Dr. Ames and others in America.

It appears that the different lines in the spectrum are differently affected, some of them being tripled with different grades of relative intensity, some doubled, some quadrupled, some sextupled and some left unchanged. Even the two components of the D lines are not similarly influenced. Moreover, whereas the polarization is usually such as to indicate that motions of a negative ion or electron constitute the source of light, a few lines are stated by the observers at Baltimore, who used what they call the 'small' grating of five inches' width

ruled with 65,000 lines, to be polarized in the reverse way.

Further prosecution of these researches must lead to deeper insight into molecular processes and the mode in which they affect the ether; indeed, already valuable theoretic views have been promulgated by H. A. Lorenz, J. Larmor and G. F. Fitzgerald, on the lines of the radiation theory of Dr. Johnstone Stoney; and the connection of the new phenomena with the old magnetic rotation of Faraday is under discussion. It is interesting to note that Faraday and a number of more recent experimenters were led by theoretical considerations to look for some such effect; and, though the inadequate means at their disposal did not lead to success, nevertheless a first dim glimpse of the phenomenon was obtained by M. Fizev, of the Royal Observatory at Brussels, in 1885.

It would be improper to pass without at least brief mention the remarkable series of theoretic papers by Dr. J. Larmor, published by the Royal Society, on the relationship between ether and matter. By the time these researches become generally intelligible they may be found to constitute a considerable step toward the further mathematical analysis and interpretation of the physical universe on the lines initiated by Newton.

In the mechanical construction of Röntgen-ray tubes I can record a few advances, the most successful being the adoption of Professor Silvanus P. Thompson's suggestion of using for the anti-cathode a metal of high atomic weight. Osmium and iridium have been used with advantage, and osmium anti-cathode tubes are now a regular article of manufacture. As long ago as June, 1896, X-ray tubes with metallic uranium anti-cathodes were made in my own laboratory, and were found to work better than those with platinum. The difficulty of procuring metallic uranium pre-

vented these experiments from being continued. Thorium anti-cathodes have also been tried.

Röntgen has drawn fresh attention to a fact very early observed by English experimenters—that of the non-homogeneity of the rays and the dependence of their penetrating power on the degree of vacuum; rays generated in high vacua have more penetrative power than when the vacuum is less high. These facts are familiar to all who have exhausted focus tubes on their own pumps. Röntgen suggests a convenient phraseology; he calls a low-vacuum tube, which does not emit the highly penetrating rays, a 'soft' tube, and a tube in which the exhaustion has been pushed to an extreme degree, in which highly-penetrating rays predominate, a 'hard' tube. Using a 'hard' tube, he took a photograph of a double-barrelled rifle, and showed not only the leaden bullets within the steel barrels, but even the wads and the charges.

Benoit has re-examined the alleged relation between density and opacity to the rays, and finds certain discrepancies. Thus, the opacity of equal thicknesses of palladium and platinum are nearly equal, whilst their densities and atomic weights are very different, those of palladium being about half those of platinum.

At the last meeting of the British Association visitors saw—at the McGill University—Professors Cox and Callendar's apparatus for measuring the velocity of Röntgen rays. They found it to be certainly greater than 200 kilometers per second. Majorana has made an independent determination, and finds the velocity to be 600 kilometers per second with an inferior limit certainly of not less than 150 kilometers per second. It may be remembered that J. J. Thomson has found for cathode rays a velocity of more than 10,000 kilometers per second, and it is extremely unlikely that the velocity of Röntgen rays will prove to be less.

Trowbridge has verified the fact, previously announced by Professor S. P. Thompson, that fluor-spar, which by prolonged heating has lost its power of luminescing when reheated, regains the power of thermo-luminescence when exposed to Röntgen rays. He finds that this restoration is also effected by exposure to the electric-glow discharge, but not by exposure to the ultra-violet light. The difference is suggestive.

As for the action of Röntgen rays on bacteria, often asserted and often denied, the latest statement by Dr. H. Rieder, of Munich, is to the effect that bacteria are killed by the discharge from 'hard' tubes. Whether the observation will lead to results of pathologic importance remains to be seen. The circumstance that the normal retina of the eye is slightly sensitive to the rays is confirmed by Dorn and by Röntgen himself.

The essential wave-nature of the Röntgen rays appear to be confirmed by the fact ascertained by several of our great mathematical physicists, that light of excessively short wave-length would be but slightly absorbed by ordinary material media, and would not in the ordinary sense be refracted at all. In fact, a theoretic basis for a comprehension of the Röntgen rays had been propounded before the rays had been discovered. At the Liverpool meeting of the British Association several speakers, headed by Sir George Stokes, expressed their conviction that the disturbed electric field caused by the sudden stoppage of the motion of an electrically-charged atom yielded the true explanation of the phenomena extraneous to the Crookes high-vacuum tubes—phenomena so excellently elaborated by Lenard and by Röntgen. More recently Sir George Stokes has re-stated his 'pulse' theory, and fortified it with arguments which have an important bearing on the whole theory of the refraction of light. He still holds to their essentially transverse

nature, in spite of the absence of polarization, an absence once more confirmed by the careful experiments of Dr. L. Graetz. The details of this theory are in process of elaboration by Professor J. J. Thomson.

Meantime, while the general opinion of physicists seems to be settling towards a wave or ether theory for the Röntgen rays, an opposite drift is apparent with respect to the physical nature of the cathode rays; it becomes more and more clear that cathode rays consist of electrified atoms or ions in rapid progressive motion. My idea of a fourth state of matter, propounded in 1881,\* and at first opposed at home and abroad, is now becoming accepted. It is supported by Professor J. J. Thomson.† Dr. Larmor's theory‡ likewise involves the idea of an ionic substratum of matter; the view is also confirmed by Zeeman's phenomenon. In Germany—where the term cathode ray was invented almost as a protest against the theory of molecular streams propounded by me at the Sheffield meeting of the British Association in 1879—additional proofs have been produced in favor of the doctrine that the essential fact in the phenomenon is electrified radiant matter.

The speed of these molecular streams has been approximately measured, chiefly by aid of my own discovery nearly twenty years ago, that their path is curved in a magnetic field, and that they produce phosphorescence where they impinge on an obstacle. The two unknown quantities, the charge and the speed of each atom, are measurable from the amount of curvature and by means of one other independent experiment.

It cannot be said that a complete and conclusive theory of these rays has yet been formulated. It is generally accepted that collisions among particles, especially

\**Phil. Trans.*, Part 2, 1881, pp. 433-434.

†*Phil. Mag.*, October, 1897, p. 312.

‡*Phil. Mag.*, December, 1897, p. 506.



the violent collisions due to their impact on a massive target placed in their path, give rise to the interesting kind of extremely high frequency radiation discovered by Röntgen. It has, indeed, for some time been known that, whereas a charged body in motion constitutes an electric current, the sudden stoppage, or any violent acceleration of such a body, must cause an alternating electric disturbance, which, though so rapidly decaying in intensity as to be practically 'dead beat,' yet must give rise to an ethereal wave or pulse travelling with the speed of light, but of a length comparable to the size of the body whose sudden change of motion caused the disturbance. The emission of a high-pitched musical sound from the jolting of a dustman's cart (with a spring bell hung on it) has been suggested as an illustration of the way in which the molecules of any solid not at absolute zero may possibly emit such rays.

If the target on to which the electrically-charged atoms impinge is so constituted that some of its minute parts can thereby be set into rythmical vibration, the energy thus absorbed reappears in the form of light, and the body is said to phosphoresce. The efficient action of the phosphorescent target appears to depend as much on its physical and molecular as on its chemical constitution. The best known phosphori belong to certain well-defined classes, such as the sulphides of the alkaline-earthly metals, and some of the so-called rare earths; but the phosphorescent properties of each of these groups are profoundly modified by an admixture of foreign bodies—witness the effect on the lines in the phosphorescent spectrum of yttrium and samarium produced by traces of calcium or lead. The persistence of the samarium spectrum in presence of overwhelming quantities of other metals is almost unexampled in spectroscopy; thus one part of

samarium can easily be seen when mixed with three million parts of lime.

Without stating it as a general rule, it seems as if with a non-phosphorescing target the energy of molecular impact reappears as pulses so abrupt and irregular that, when resolved, they furnish a copious supply of waves of excessively short wave-length—in fact, the now well-known Röntgen rays. The phosphorescence so excited may last only a small fraction of a second, as with the constituents of yttria, where the duration of the different lines varies between the 0.003 and the 0.0009 second; or it may linger for hours, as in the case of some of the yttria earths, and especially with the earthy sulphides, where the glow lasts bright enough to be commercially useful. Excessively phosphorescent bodies can be excited by light waves, but most of them require the stimulus of electrical excitement.

It now appears that some bodies, even without special stimulation, are capable of giving out rays closely allied, if not in some cases identical, with those of Professor Röntgen. Uranium and thorium compounds are of this character, and it would almost seem, from the important researches of Dr. Russell, that this ray-emitting power may be a general property of matter, for he has shown that nearly every substance is capable of affecting the photographic plate if exposed in darkness for sufficient time.

No other source for Röntgen rays but the Crookes tube has yet been discovered, but rays of kindred sorts are recognized. The Becquerel rays, emitted by uranium and its compounds, have now found their companions in rays—discovered almost simultaneously by Curie and Schmidt—emitted by thorium and its compounds. The thorium rays affect photographic plates through screens of paper or aluminium, and are absorbed by metals and other dense bodies. They ionize the air, making it an electrical

conductor; and they can be refracted and probably reflected, at least diffusively. Unlike uranium rays, they are not polarized by transmission through tourmaline, therefore resembling in this respect the Röntgen rays.

Quite recently M. and Mme. Curie have announced a discovery which, if confirmed, cannot fail to assist the investigation of this obscure branch of physics. They have brought to notice a new constituent of the uranium mineral pitchblende, which in a 400-fold degree possesses uranium's mysterious power of emitting a form of energy capable of impressing a photographic plate and of discharging electricity by rendering air a conductor. It also appears that the radiant activity of the new body, to which the discoverers have given the name of polonium, needs neither the excitation of light nor the stimulus of electricity; like uranium, it draws its energy from some constantly regenerating and hitherto unsuspected store, exhaustless in amount.

It has long been to me a haunting problem how to reconcile this apparently boundless outpour of energy with accepted canons. But, as Dr. Johnstone Stoney reminds me, the resources of molecular movements are far from exhausted. There are many stores of energy in nature that may be drawn on by properly constituted bodies without very obvious cause. Some time since I drew attention to the enormous amount of locked-up energy in the ether; nearer our experimental grasp are the motions of the atoms and molecules, and it is not difficult mentally so to modify Maxwell's demons as to reduce them to the level of an inflexible law and thus bring them within the ken of a philosopher in search of a new tool. It is possible to conceive a target capable of mechanically sifting from the molecules of the surrounding air the quick from the slow movers. This sifting of the swift moving molecules is effected in liquids whenever they evaporate, and in the case of the con-

stituents of the atmosphere, wherever it contains constituents light enough to drift away molecule by molecule. In my mind's eye I see such a target as a piece of metal cooler than the surrounding air acquiring the energy that gradually raises its temperature from the outstanding effect of all its encounters with the molecules of the air about it; I see another target of such a structure that it throws off the slow moving molecules with little exchange of energy, but is so influenced by the quick moving missiles that it appropriates to itself some of their energy. Let uranium or polonium, bodies of densest atoms, have a structure that enables them to throw off the slow moving molecules of the atmosphere, while the quick moving molecules, smashing on to the surface, have their energy reduced and that of the target correspondingly increased. The energy thus gained seems to be employed partly in dissociating some of the molecules of the gas (or in inducing some other condition which has the effect of rendering the neighboring air in some degree a conductor of electricity) and partly in originating an undulation through the ether, which, as it takes its rise in phenomena so disconnected as the impacts of the molecules of the air, must furnish a large contingent of light waves of short wave-length. The shortness in the case of these Becquerel rays appears to approach without attaining the extreme shortness of ordinary Röntgen rays. The reduction of the speed of the quick moving molecules would cool the layer of air to which they belong, but this cooling would rapidly be compensated by radiation and conduction from the surrounding atmosphere; under ordinary circumstances the difference of temperature would scarcely be perceptible, and the uranium would thus appear to perpetually emit rays of energy with no apparent means of restoration.

The total energy of both the translational

and internal motions of the molecules locked up in quiescent air at ordinary pressure and temperature is about 140,000 foot-pounds in each cubic yard of air. Accordingly the quiet air within a room 12 feet high, 18 feet wide and 22 feet long contains energy enough to propel a one-horse engine for more than twelve hours. The store drawn upon naturally by uranium and other heavy atoms only awaits the touch of the magic wand of Science to enable the twentieth century to cast into the shade the marvels of the nineteenth.

Whilst placing before you the labors and achievements of my comrades in science I seize this chance of telling you of engrossing work of my own on the fractionation of yttria to which for the last eighteen years I have given ceaseless attention. In 1883, under the title of 'Radiant Matter Spectroscopy,' I described a new series of spectra produced by passing the phosphorescent glow of yttria, under molecular bombardment *in vacuo*, through a train of prisms. The visible spectra in time gave up their secrets, and were duly embalmed in the *Philosophical Transactions*. At the Birmingham meeting of the British Association in 1886 I brought the subject before the Chemical Section, of which I had the honor to be President. The results led to many speculations on the probable origin of all the elementary bodies—speculations that for the moment I must waive in favor of experimental facts.

There still remained for spectroscopic examination a long tempting stretch of unknown ultra-violet light, of which the exploration gave me no rest. But I will not now enter into details of the quest of unknown lines. Large quartz prisms, lenses and condensers, specially sensitized photographic films capable of dealing with the necessary small amount of radiation given by feebly phosphorescing substances,\* and,

\*In this connection I am glad to acknowledge my

above all, tireless patience in collating and interpreting results, have all played their part. Although the research is incomplete, I am able to announce that among the groups of rare earths giving phosphorescent spectra in the visible region there are others giving well-defined groups of bands which can only be recorded photographically. I have detected and mapped no less than six such groups extending to  $\lambda$  3060.

Without enlarging on difficulties, I will give a brief outline of the investigation. Starting with a large quantity of a group of the rare earths in a state of considerable purity, a particular method of fractionation is applied, splitting the earths into a series of fractions differing but slightly from each other. Each of these fractions, phosphorescing *in vacuo*, is arranged in the spectrograph; and a record of its spectrum photographed upon a specially prepared sensitive film.

In this way, with different groups of rare earths, the several invisible bands were recorded—some moderately strong, others exceedingly faint. Selecting a portion giving a definite set of bands, new methods of fractionation were applied, constantly photographing and measuring the spectrum of each fraction. Sometimes many weeks of hard experiment failed to produce any separation, and then a new method of splitting up was devised and applied. By unremitting work—the solvent of most difficulties—eventually it was possible to split up the series of bands into various groups. Then, taking a group which seemed to offer possibilities of reasonably quick result, one method after another of chemical attack was adopted, with the ultimate result of freeing the group from its accompanying

indebtedness to Dr. Schumann, of Leipzig, for valuable suggestions and detail of his own apparatus, by means of which he has produced some unique records of metallic and gaseous spectra of lines of short wavelength.



fellows and increasing its intensity and detail.

As I have said, my researches are far from complete, but about one of the bodies I may speak definitely. High up in the ultra-violet, like a faint nebula in the distant heavens, a group of lines was detected, at first feeble and only remarkable on account of their isolation. On further purification these lines grew stronger. Their great refrangibility cut them off from other groups. Special processes were employed to isolate the earth, and using these lines as a test, and appealing at every step to the spectrograph, it was pleasant to see how each week the group stood out stronger and stronger, while the other lines of yttrium, samarium, ytterbium, etc., became fainter, and, at last, practically vanishing, left the sought-for group strong and solitary. Finally, within the last few weeks, hopefulness has emerged into certainty, and I have absolute evidence that another member of the rare earth groups has been added to the list. Simultaneously with the chemical and spectrographic attack, atomic-weight determinations were constantly performed.

As the group of lines which betrayed its existence stand alone, almost at the extreme end of the ultra-violet spectrum, I propose to name the newest of the elements Monium, from the Greek *μόνος*, alone. Although caught by the searching rays of the spectrum, monium offers a direct contrast to the recently discovered gaseous elements, by having a strongly-marked individuality; but, although so young and willful, it is willing to enter into any number of chemical alliances.

Until my material is in a greater state of purity I hesitate to commit myself to figures, but I may say that the wave-lengths of the principal lines are 3120 and 3117. Other fainter lines are at 3219, 3064 and 3060. The atomic weight of the element, based on the assumption of  $R_2O_3$ , is not far

from 118—greater than that accepted for yttrium and less than that for lanthanum.

I ought almost to apologize for adding to the already too long list of elements of the rare earth class—the asteroids of the terrestrial family. But as the host of celestial asteroids, unimportant individually, become of high interest when once the idea is grasped that they may be incompletely coagulated remains of the original nebula, so do these elusive and insignificant rare elements rise to supreme importance when we regard them in the light of component parts of a dominant element, frozen in embryo, and arrested in the act of coalescing from the original protyle into one of the ordinary and law-abiding family for whom Newlands and Mendeleeff have prepared pigeon-holes. The new element has another claim to notice. Not only is it new in itself, but to discover it a new tool had to be forged for spectroscopic research.

Further details I will reserve for that tribunal before whom every aspirant for a place in the elemental hierarchy has to substantiate his claim.

These, then, are some of the subjects, weighty and far-reaching, on which my own attention has been chiefly concentrated. Upon one other interest I have not yet touched—to me the weightiest and the farthest reaching of all.

No incident in my scientific career is more widely known than the part I took many years ago in certain psychic researches. Thirty years have passed since I published an account of experiments tending to show that outside our scientific knowledge there exists a Force exercised by intelligence differing from the ordinary intelligence common to mortals. This fact in my life is, of course, well understood by those who honored me with the invitation to become your President. Perhaps among my audience some may feel curious as to whether I shall speak out or be silent. I elect to speak,

although briefly. To enter at length on a still debatable subject would be unduly to insist on a topic which—as Wallace, Lodge and Barrett have already shown—though not unfitted for discussion at these meetings, does not yet enlist the interest of the majority of my scientific brethren. To ignore the subject would be an act of cowardice—an act of cowardice I feel no temptation to commit.

To stop short in any research that bids fair to widen the gates of knowledge, to recoil from fear of difficulty or adverse criticism, is to bring reproach on science. There is nothing for the investigator to do but to go straight on; 'to explore up and down, inch by inch, with the taper his reason;' to follow the light wherever it may lead, even should it at times resemble a will-o'-the-wisp. I have nothing to retract. I adhere to my already published statements. Indeed, I might add much thereto. I regret only a certain crudity in those early expositions which, no doubt justly, militated against their acceptance by the scientific world. My own knowledge at that time scarcely extended beyond the fact that certain phenomena new to science had assuredly occurred, and were attested by my own sober senses and, better still, by automatic record. I was like some two-dimensional being who might stand at the singular point of a Riemann's surface, and thus find himself in infinitesimal and inexplicable contact with a plane of existence not his own.

I think I see a little farther now. I have glimpses of something like coherence among the strange elusive phenomena; of something like continuity between those unexplained forces and laws already known. This advance is largely due to the labors of another association of which I have also this year the honor to be President—the Society for Psychical Research. And were I now introducing for the first time these

inquiries to the world of science I should choose a starting-point different from that of old. It would be well to begin with *telepathy*; with the fundamental law, as I believe it to be, that thoughts and images may be transferred from one mind to another without the agency of the recognized organs of sense—that knowledge may enter the human mind without being communicated in any hitherto known or recognized ways.

Although the inquiry has elicited important facts with reference to the mind, it has not yet reached the scientific stage of certainty which would entitle it to be usefully brought before one of our Sections. I will, therefore, confine myself to pointing out the direction in which scientific investigation can legitimately advance. If telepathy take place we have two physical facts—the physical change in the brain of A, the suggester, and the analogous physical change in the brain of B, the recipient of the suggestion. Between these two physical events there must exist a train of physical causes. Whenever the connecting sequence of intermediate causes begins to be revealed, the inquiry will then come within the range of one of the Sections of the British Association. Such a sequence can only occur through an intervening medium. All the phenomena of the universe are presumably in some way continuous, and it is unscientific to call in the aid of mysterious agencies when, with every fresh advance in knowledge, it is shown that ether vibrations have powers and attributes abundantly equal to any demand—even to the transmission of thought. It is supposed by some physiologists that the essential cells of nerves do not actually touch, but are separated by a narrow gap which widens in sleep, while it narrows almost to extinction during mental activity. This condition is so singularly like that of a Branly or Lodge coherer as to suggest a further analogy.

The structure of brain and nerve being similar, it is conceivable there may be present masses of such nerve coherers in the brain whose special function it may be to receive impulses brought from without through the connecting sequence of ether waves of appropriate order of magnitude. Röntgen has familiarized us with an order of vibrations of extreme minuteness compared with the smallest waves with which we have hitherto been acquainted, and of dimensions comparable with the distances between the centers of the atoms of which the material universe is built up; and there is no reason to suppose that we have here reached the limit of frequency. It is known that the action of thought is accompanied by certain molecular movements in the brain, and here we have physical vibrations capable; from their extreme minuteness, of acting direct on individual molecules, while their rapidity approaches that of the internal and external movements of the atoms themselves.

Confirmation of telepathic phenomena is afforded by many converging experiments and by many spontaneous occurrences only thus intelligible. The most varied proof, perhaps, is drawn from analysis of the subconscious workings of the mind, when these, whether by accident or design, are brought into conscious survey. Evidence of a region below the threshold of consciousness has been presented, since its first inception, in the *Proceedings of the Society for Psychical Research*; and its various aspects are being interpreted and welded into a comprehensive whole by the pertinacious genius of F. W. H. Myers. Concurrently, our knowledge of the facts in this obscure region has received valuable additions at the hands of laborers in other countries. To mention a few names out of many, the observations of Richet, Pierre Janet and Binet (in France), of Breuer and Freud (in Austria), of William James (in America), have strik-

ingly illustrated the extent to which patient experimentation can probe subliminal processes, and can thus learn the lessons of alternating personalities and abnormal states. Whilst it is clear that our knowledge of subconscious mentation is still to be developed, we must beware of rashly assuming that all variations from the normal waking condition are necessarily morbid. The human race has reached no fixed or changeless ideal; in every direction there is evolution as well as disintegration. It would be hard to find instances of more rapid progress, moral and physical, than in certain important cases of cure by suggestion—again to cite a few names out of many—by Liébeault, Bernheim, the late Auguste Voisin, Bérillon (in France), Schrenck-Notzing (in Germany), Forel (in Switzerland), van Eeden (in Holland), Wetterstrand (in Sweden), Milne-Bramwell and Lloyd Tuckey (in England). This is not the place for details, but the *vis medicatrix* thus evoked, as it were, from the depths of the organism, is of good omen for the upward evolution of mankind.

A formidable range of phenomena must be scientifically sifted before we effectually grasp a faculty so strange, so bewildering, and for ages so inscrutable, as the direct action of mind on mind. This delicate task needs a rigorous employment of the method of exclusion—a constant setting aside of irrelevant phenomena that could be explained by known causes, including those far too familiar causes, conscious and unconscious fraud. The inquiry unites the difficulties inherent in all experimentation connected with *mind*, with tangled human temperaments and with observations dependent less on automatic record than on personal testimony. But difficulties are things to be overcome even in the elusory branch of research known as Experimental Psychology. It has been characteristic of the leaders among the group of inquirers constituting



the Society for Psychical Research to combine critical and negative work with work leading to positive discovery. To the penetration and scrupulous fair-mindedness of Professor Henry Sidgwick and of the late Edmund Gurney is largely due the establishment of canons of evidence in psychical research, which strengthen while they narrow the path of subsequent explorers. To the detective genius of Dr. Richard Hodgson we owe a convincing demonstration of the narrow limits of human continuous observation.

It has been said that 'Nothing worth the proving can be proved, nor yet disproved.' True though this may have been in the past, it is true no longer. The science of our century has forged weapons of observation and analysis by which the veriest tyro may profit. Science has trained and fashioned the average mind into habits of exactitude and disciplined perception, and in so doing has fortified itself for tasks higher, wider, and incomparably more wonderful than even the wisest among our ancestors imagined. Like the souls in Plato's myth that follow the chariot of Zeus, it has ascended to a point of vision far above the earth. It is henceforth open to science to transcend all we now think we know of matter, and to gain new glimpses of a profounder scheme of Cosmic Law.

An eminent predecessor in his chair declared that "by an intellectual necessity he crossed the boundary of experimental evidence, and discerned in that matter, which we in our ignorance of its latent powers, and notwithstanding our professed reverence for its Creator, have hitherto covered with opprobrium, the potency and promise of all terrestrial life." I should prefer to reverse the apothegm, and to say that in life I see the promise and potency of all forms of matter.

In old Egyptian days a well-known inscription was carved over the portal of the

temple of Isis: "I am whatever hath been, is, or ever will be; and my veil no man hath yet lifted." Not thus do modern seekers after truth confront nature—the word that stands for the baffling mysteries of the universe. Steadily, unflinchingly, we strive to pierce the inmost heart of Nature, from what she is to reconstruct what she has been, and to prophesy what she yet shall be. Veil after veil we have lifted, and her face grows more beautiful, august and wonderful, with every barrier that is withdrawn.

WILLIAM CROOKES.

#### RECENT ADVANCES IN MALACOLOGY.

WE have received lately, though the work has been some time issued, the second Lieferung of Bergh's Malacological Researches on the collections made by Semper in the Philippines.\* The fasciculus in question treats of the *Pleurobranchida* in the masterly manner and with all the wealth of anatomical detail and illustration which this author has taught us to expect from him. The text is devoted to an exhaustive anatomical account of *Oscanius*, beginning with the Mediterranean type *O. membranaceus*, *Oscaniopsis* and *Oscaniella* Bergh, new genera, the first exclusively Indo-chinese and the second chiefly so, but having one Antillean representative. The plates include full data on two species of the eastern United States, *Pleurobranchæa tarda* Verrill and *P. obesa* Verrill, the genus *Koonsia*, originally proposed for the latter, being regarded as identical with *Pleurobranchæa* by Bergh.

A very full and useful monograph of the *Dreissensida* of the Palearctic region has been published by N. Andrusov in the Russian language,† the plates of which have

\* Reisen im Archipel der Philippinen von C. Semper. Bd. VII., IVte Abth. Die Pleurobranchiden von Dr. Rudolph Bergh, Wiesbaden, 1897.

†Travaux de la Soc. des Naturalistes de St. Petersburg. Sect. Géol. et Min., Vol. XXV., 4to, 1895, avec 20 planches phot.

been distributed with an octavo résumé of 115 pages in German. In the recent fauna *Dreissensia* is confined to Europe and western Asia, while *Congeria* is distributed in west Africa and the tropical and sub-tropical regions of America. This is curious, since fossil *Congeria*s are extremely abundant in some of the Tertiaries of eastern Europe. A small area in Farther India produces mollusks not distinguishable by the shell from *Dreissensia*, but which our author suspects are different anatomically and refers to as pseudo-*Dreissensia*. Notwithstanding the abundance of *Dreissensia* in Europe and of *Congeria* almost under the shadow of the Johns Hopkins University, a complete account of the anatomy is still a desideratum, while the imperfect data recorded have given rise to the most diverse hypotheses as to the relations of this family, of which by far the larger number of species are only known in a fossil state.

Although somewhat belated, notice should be taken of a magnificent contribution to the paleontology of the Alpine Trias by A. Bittner.\* This work is devoted to the Pelecypoda of St. Cassian, covering fifty-six genera, of which ten are newly instituted. One of these, *Arcoptera* Bittner, bears a name which has already been used by Heilprin for a Pliocene fossil.† The later genus is based on two very elegant little species of *Arcaea*, and we would suggest that the preoccupied name be replaced by *Bittnerella*. The fauna is one of classic interest, and is illustrated lavishly by admirable lithographic plates.

The current volume of the *Journal de Conchyliologie* contains an important article by H. Fischer, summarizing the works of the late Dr. Felix Bernard on the de-

velopment of the shell in *Pelecypoda*.\* The premature decease of this promising and estimable student came as a shock to those who had admired and profited by his excellent researches. While one might feel disinclined to accept in their entirety the theories he based upon them, the collection of new facts relating to the development of the hinge in Pelecypods is a solid contribution to science for which we shall always be in his debt, while his excellent anatomical papers have met general commendation. Dr. Fischer's summary, in default of the general work contemplated by Bernard, will possess a permanent value.

In this connection we may express our regret at the death of the veteran M. Hippolyte Crosse, senior editor of the *Journal*, to which he devoted many years of conscientious and conservative attention. M. Crosse had attained the age of 71 years, and died on the 7th of August last, followed five days later by Bernard, in the 35th year of his age—two most regrettable losses for French malacology.

We are informed, though it has not yet come to hand, that an index to the last twenty volumes of the *Journal* has been issued, which will be indispensable to all students of mollusks, recent or fossil. We trust that the editorial staff will in future do away with the inconvenient practice of antedating the issues of the *Journal*, which has gradually come about of late years through the delay in publishing some of the numbers. The volume for 1897 (largely issued in 1898), besides the paper above mentioned, includes interesting data on the genus *Cypraea* in the Mediterranean, by the Marquis de Monterosato; on minute shells from the New Caledonian Archipelago, by the R. P. J. Hervier, and on the Quaternary fossil shells collected by M. Piette in the cave of Mas d'Azil (Ariège), by Dr. H. Fischer.

\*Revision des Lamellibranchiatiens von St. Cassian. Abh. K. K. Geol. Reichsanst. Bd. XVIII., Heft. 1, 236 pp., 24 pl., 4to.

†Trans. Wagner Inst. Sci., Philadelphia, Vol. 1, 1885.

\**Journ. de Conchyl.*, Vol. XLV., No. 4, pp. 209-224, 1898.

The last number of the Proceedings of the Malacological Society\* contains several articles of more than average interest. The anatomy of *Mülleria* has long been a desideratum and the typical Columbian species *M. lobata* is still undescribed. Very unexpectedly a second species turned up in southern India, and from specimens of this form M. F. Woodward has been able to give a very complete account of its anatomical features. It is known that in the young the usual anterior adductor of Pelecypods is developed, but the creature soon becomes sessile and the adult shell presents a remarkable resemblance to an oyster and, like the oyster, preserves only its posterior adductor. The gills are normal, reticulate, and so attached to the mantle as to separate the anal and branchial chambers; but the margins of the mantle remain free. The foot is entirely abortive, but the pedal ganglia remain; the rectum is entirely free from the pericardium and heart, and there is no provision for a branchial marsupium, as in the *Naiades*. On the whole the characters support the opinion previously based upon the shell, that *Mülleria* is related to the *Naiades*, but presents extreme modifications due to the sessile habit.

In the same number (pp. 85, 86) Dall gives an account of the macroscopic anatomy of the two peculiar New Zealand genera, *Resania* and *Zenatia*, Gray; of which nothing was previously known. Their relationship to the *Maetracea* is established. In *Resania* the anal and branchial chambers are separated (as in *Verticordia*) by a fleshy septum independent of the gills, and the ctenidia in five adult specimens agreed in being asymmetrical and in having the pendant laminae on the left side discontinuous longitudinally, the anterior portion being separated from the posterior by a vacant space.

We have also (pp. 94-104) a discussion

\*Vol. III., No. 2, July, 1898, pp. 63-110.

of the classification of the slugs of the family *Arionidae* by Professor H. A. Pilsbry, preceded by an account of the anatomy of *Anadenus* and notes on *Geomalacus*. He finds the modifications of the free muscles most fundamental in this group. Geographically the family occupies three widely separated areas which have no common genera. The most primitive forms are American, and an American origin for the family is regarded as probable. Their phylogenetic tree is supposed to have its roots in the *Endodontidae* and its culmination in the genus *Arion*. *Binneya* is regarded as a connecting link with the *Endodontidae*, and the family may have spread to Asia by way of an Alaskan land connection.

One of the most interesting recent contributions to malacology is that on the fresh-water mollusks of Celebes by the brothers Sarasin.\* In the heart of the island, amid high mountains, is the large Lake Passo, lying in a depression of ancient non-volcanic rocks. Close to its shores, covered with a moderate depth of water, is a sandy border which descends abruptly into much deeper water, which has a muddy bottom. On the sandy terrace live many fresh-water shells, and the beaches are abundantly strewn with them. Other lakes have a not very different shell fauna, but in Lake Passo was found the curious Linnæid genus *Miratesta*, one of the prizes of the expedition. The shell is heavy and sinistral, with coarse sculpture, and the animal possesses a large and well developed gill and a peculiarly muscular buccal mass. The dentition is close to that of *Limnæa* and *Isidora*. The latter genus also occurs, and the authors show that *Pulmobranchia* Pelseneer (as pointed out in this JOURNAL, N. S., IV., p. 772, 1896), is synonymous with *Isidora* Ehrenberg (*Ameria*

\* Die Süßwasser-mollusken von Celebes, von Drs. Paul and Fritz Sarasin. Wiesbaden, C. W. Kreidel. 1898. VIII., 104 pp., 13 pl., 4to.



H. Adams), which has as one of its characters a more or less completely developed gill. A new genus of the patelliform Limnæids, *Protanelylus*, from the lakes of Celebes differs by the same character from the Palæarctic *Ancylus*. The authors suggest that these facts indicate that these forms retain ancient characters belonging to a time when the fresh-water Pulmonates were less differentiated from the marine Opisthobranchiates than at present. Welcome details are also given of the opercula and radula of various Melanians and *Viviparidae*. There are a few *Neritina*, two *Corbicula* and a species of *Batissa*, but one of the curiosities of the Celebes fauna is the absence of Naiades, though the latter occur both east and west of Celebes, in Borneo and Australasia.

WM. H. DALL.

AN INSTANCE OF LOCAL TEMPERATURE  
CONTROL OF THE DISTRIBUTION OF  
MAMMALS.

It is a well-known fact that boreal mammals, such as lemmings (*Synaptomys*), red-backed mice (*Eutamias*) and long-tailed shrews (*Sorex*), are found locally in cool situations far to the south of their normal range. The faunal status of the species is thus in no way altered, however; for the occurrence of an animal beyond its usual geographic limits does not prove that the species can defy the influences of climate.

While every life zone undoubtedly has its outlying islands, perhaps the best-known instances of the phenomenon are the small boreal areas scattered through the transition zone and northern part of the upper austral zone in the eastern United States. Many of the 'boreal islands' are found on mountain tops, where their presence is readily explained by the low temperature of high elevations, but others occur practically at sea level, or at an altitude much below that normally

attained by the zone in which they lie. Good descriptions of 'islands' of this kind have been recently published by Mr. Vernon Bailey and Mr. Chas F. Batchelder. Mr. Bailey calls attention to 'Tamarack Swamps as Boreal Islands,'\* and mentions the fact that the layer of sphagnum with which these swamps are generally carpeted acts as a cooling agent, partly by protecting the ice which during the winter forms beneath it, and partly by inducing evaporation, by which the air at the surface is continually cooled. He found many 'islands' of this kind in the upper austral zone near Ann Arbor, Michigan. Mr. Batchelder describes the cold rock slides in which the Hudsonian *Microtus chrotorrhinus* occurs in the Canadian zone of the Adirondacks, and the swamps that afford the Canadian *Eutamias gapperi* a congenial home in the transition zone of southern New England.† The so called 'rock vole,' *Microtus chrotorrhinus* was found in Essex County, New York, on "a steep hillside heavily wooded with an old mixed growth. The lower slopes were made up of a talus of large angular blocks of rocks piled one upon another as they had fallen from the cliffs above. The damp rocks were covered with sphagnum and ferns, and from the holes and spaces between them came currents of cold air, indicating the presence of masses of yet [August 29] unmelted ice somewhere in the depths below." Of *Eutamias* in southeastern New England he says: "One may look for it with some confidence in almost any large tract of wet ground that retains its moisture through the summer, but is not subject to serious floods, and which bears a growth of woods sufficiently heavy to afford it dense shade, so that the ground beneath and the roots of the trees are covered with a deep carpet of sphagnum. \* \*

\*SCIENCE, N. S., III., p. 250, February 14, 1896.

†Proc. Boston Soc. Nat. Hist., XXVII., pp. 188 and 192-193, October, 1896.

\* \* One of the most evident peculiarities of such a spot as this, in southern New England, is that the dense shade and abundant evaporation maintain a temperature during the hottest summer weather that is far below that of the surrounding country. In these aspects of coolness, moisture and shade there is a striking resemblance to the woods *Eutamias gapperi* inhabits in extreme northern New England and other parts of the Canadian zone." These accounts, interesting and suggestive as they are, give no clue to the exactness of correspondence between the temperature of the southern boreal islands and that of the main northern part of the boreal zone. So far as I am aware, no attempt to correlate the two has yet been published.

During the summer of 1897 I had the opportunity to make some approximately exact observations on the relative temperatures of a 'boreal island' and the immediately contiguous upper austral zone in the bottom of Fort Valley, at the north end of Massanutten Mountain, Warren County, Virginia. The locality was so inaccessible—to reach it and return necessitated a drive of nearly twenty miles—that only a small part of the day could be spent in making observations, and my instruments were merely cheap thermometers bought at a country store; but, in spite of these obstacles in the way of completeness and accuracy, the results are sufficiently positive to show how important a field is open for similar work done under favorable conditions and with accurate instruments.

Fort Valley lies between two parallel ranges of low mountains, extending nearly north and south, between the forks of the Shenandoah River. Its eastern side is formed by the abrupt, regular, western slope of Massanutten Mountain. On its western side the slope is less precipitous, and the mountain chain is much broken into separate peaks and irregular ridges. At its point of open-

ing into the broad level Shenandoah Valley, two miles south of the railroad station of Waterlick, Fort Valley is narrowed to a mere pass, scarcely wide enough to allow the exit of a small stream, Passage Creek, and a wagon road. At this point the bottom of Fort Valley is only about 750 feet above sea-level, and scarcely 200 feet above the nearest point on the Shenandoah River. On the east Massanutten Mountain rises to an elevation of some 1,800 feet, and on the west Three Top Mountain barely reaches 2,300 feet. Just here the west slope of Massanutten Mountain is unusually precipitous. For several hundred feet below the summit the face of the mountain is a sheer, bare cliff; below this a rough talus slopes abruptly to the edge of Passage Creek.

The upper austral flora of the Shenandoah Valley passes uninterruptedly over these low mountains and through Fort Valley. Near the mouth of the Fort a few characteristic species, such as the pawpaw and persimmon, both of which are very common immediately outside, disappear, but this is evidently due to lack of congenial soil, as both grow at much greater heights on the neighboring mountains. A fine growth of hemlock gives the place a somewhat un-austral aspect, but these trees are freely interspersed with gums (*Nyssa*), three-leaved hop trees (*Ptelea*), fringe trees (*Chionanthus*), tulip trees (*Liriodendron*) and southern bass woods (*Tilia pubescens*)—a typical austral assemblage.

The mammal fauna outside of the 'boreal islands' showed no peculiarities. It was simply that of the upper austral zone, and it extended wherever I trapped on the mountains as well as in the valleys. Among the hills on the west side of Fort Valley are a few small cold streams, and on the banks of these I secured two boreal mammals, a red-backed mouse (*Eutamias carolinensis*) and a shrew (*Sorex fumeus*). The nearest points from which the former has been recorded are Roan Mountain, North Caro-

lina,\* altitude 6,000 feet, and Travellers' Repose, West Virginia,\* altitude about 3,000 feet. The shrew is recorded from Roan Mountain † and from the higher mountains of central Pennsylvania. ‡ Both of these animals occurred also in considerable numbers among the loose rocks of the talus at the narrowest part of Fort Valley, altitude 750 feet. § This boreal colony was completely surrounded by the upper austral fauna, which extended more than a thousand feet above it. The mammal fauna of the talus slope was not made up exclusively of these two species. As might be expected, such abundant, freely roaming austral forms as the wood rat (*Neotoma pennsylvanica*), white-footed mouse (*Peromyscus leucopus leucopus*), and chipmunk (*Tamias striatus striatus*), were often caught in traps set among the loose rock masses. These common species would naturally wander from the woods over the comparatively small area of the rock slide in search of food. A single short-tailed shrew (*Blarina brevicauda*) was taken there also. This animal, however, ranges freely into the boreal zone. ||

As I have already said, the talus sloped abruptly to the edge of Passage Creek. It was in no way peculiar, but had all the well-known characteristics of such formations. It supported a very scant tree growth. The rock fragments were overgrown with lichens, and in protected places there were large mats of moss and ferns, but I found no sphagnum. At the point where my temperature observations were

made, a widely open cavity had been formed beneath some unusually large rock fragments held from slipping downward by the roots of trees. From this cavity at the base of the talus, as well as from smaller ones on its sides, there was a constant outpour of cold, damp air. This was especially noticeable on hot, still days, when the air currents kept the ferns about the mouths of the crevices continually waving, while all other vegetation was motionless. From the large cavity to the edge of the water was a distance of about ten feet. ¶ The rocky bed of the stream at this point was only some twenty feet wide. On the opposite side of the stream was a flood-plain, perhaps twenty yards across. It was very irregular in surface, and consisted merely of masses of sand brought down from the valley above during freshets and lodged among the rocks. The flood-plain was well wooded, first with a fringe of shrubs and further back from the stream bed with a vigorous growth of trees, such as I have already described. Beyond the flood-plain rose the gradual slope of Three Top Mountain. Although parts of the flood-plain afforded what appeared to be perfect shelter for red-backed mice and smoky shrews, the most careful trapping failed to bring to light anything but the common upper austral mammals. Colonies of pine mice (*Microtus pinetorum*) occupied places that were sufficiently sandy, and white-footed mice abounded. I also detected the work of a mole which appeared to be that of *Scalops aquaticus*. It is safe to say that at this point the typical boreal species were strictly confined to the talus, the more sedentary austral forms to the flood-plain and warm mountain sides, but that the more active and abundant austral species wandered freely in search of food.

For temperature observations I established four stations. Station 1 was on the flood-plain at the base of Three Top Moun-

\* Bailey, Proc. Biolog. Soc. Washington, XI., p. 130, May 13, 1897.

† Merriam, North American Fauna, No. 10, p. 66, December 31, 1895.

‡ Rhoads, Proc. Acad. Nat. Sci., Philadelphia, 1897, p. 223, May, 1897.

§ The altitudes of localities in this region are from the Lrny sheet of the United States Geological Survey Topographic Map.

|| See Miller, Proc. Boston Soc. Nat. Hist., XXVIII., p. 38, April 30, 1897.



tain; station 2 was a few yards back from the edge of the stream directly opposite the large cavity in the talus; station 3 was at the water's edge on the opposite side of the stream from station 2, and station 4 was in the cavity at the foot of the talus. At each station the thermometers were placed on the surface of the ground in positions where they would be protected from all direct rays of the sun, and so far as possible from any influence of reflected heat. The conditions at station 4 were somewhat exceptional, but even here the thermometer was not placed under ground, but on the surface of the rocks beneath the overhanging roof of the widely open cavity. The detailed results of the readings are given the following table:

Date 1897	Hour P. M.	Station.				Water.	Sky.
		1	2	3	4		
Aug. 20.	1.20	72.5°				69°	Sl'tly cloudy
" "	2.15						" "
" "	2.40	67°	64°	58°			" "
" "	2.50		63°	57°			" "
" "	3.40		68°	59°			Clouds hea'y
" "	4.00		66°				" "
" "	4.30	70°		59°			" "
" 22	1.00	75.5°					" thin
" "	1.30		72°		59°	72°	" "
" "	2.30		72°				Almost clear
" "	3.10		72°				Clear
" "	3.50				61°		" "
" "	4.20	75°					Clouds thin
" 24	12.45	69°					" "
" "	1.30	71°	70°			66°	Clear
" "	2.15		79°				" "
" "	3.40		68°		60°		" "
" 30	1.30	77°		60°		71°	Clouds dense
" "	2.20		79°		58°		" thin
" "	8.45		72°		58°		" dense
Sept. 1	2.00	74°				73°	Clear
" "	2.30		77°		58°		" "
" "	3.30				58°		" "
" "	3.40		74°		58°		" "
" 5	2.30			67°			" "
" "	3.20	73°		54°			" "
" "	4.00					70°	" "
" 7	1.10	88°					" "
" "	2.45		80°	63°			" "
" "	3.00			56°		70°	" "
" "	5.40		74°	56°			" "
" 9	5.00		79°	66°			" "
" "	5.10			56°			" "
" "	5.45		76°				" "
" 11	3.00		80°	67°		73°	" "
" "	3.40		80°				" "
" "	5.30		74°		57°		" "
" 13	3.00			67°		73°	" "
" "	3.30	79°			58°		" "
" "	4.20				58°		" "
" "	5.30	78°			58°		" "
Mean.		74.6°	75°	65.7°	57.8°	70.7°	" "

The readings at stations 2 and 4, being the most important to compare, are printed in heavy type. It is to be remembered that

these two stations were less than fifty feet apart.

On comparing the means of the readings at stations 2 and 4 it is seen that the boreal mammals lived in an atmosphere the mean temperature of which, during the afternoon, at nearly the hottest part of the summer, was about 17° lower than that of the region occupied by the upper austral fauna. How this relationship might be altered by including observations taken throughout the day and night can only be guessed at, but I think it would remain essentially the same. The question next arises as to how nearly the means of 75° and 58° correspond with the known means, for the same season, of the upper austral zone and boreal zone respectively. Turning to the only published table of zone temperatures\* we find that the range of normal mean temperature of the six hottest consecutive weeks at extreme northern and southern localities in the two zones is as follows: upper austral, 71° to 78°; boreal (Canadian), 57° to 64°. In each case, therefore, the mean temperature of the station coincided with that of the life zone to which the fauna of the station belonged.

GERRIT S. MILLER, JR.

U. S. NATIONAL MUSEUM.

#### THE ANNUAL INSPECTION OF THE PRIBILOF SEAL ROOKERIES.

IN compliance with the Act of Congress of 1893, the U. S. Fish Commission has each year made an investigation respecting the condition of seal life on the Pribilof Islands.

This work, usually performed in connection with former duties on the steamer *Albatross*, was officially resumed by the writer during the past season in connection with the work of the Division of Fisheries.

\*Merriam, Laws of Temperature Control of the Geographic Distribution of Terrestrial Animals and Plants. *The National Geographic Magazine*, VI., pp. 229-233, December, 1894.

Owing to the continuance of pelagic sealing the seals are still diminishing in numbers, and the seal catch on land and sea grows less from year to year. The percentage of decrease in the number of seals born on the islands becomes more noticeable as time passes, the operations of the sealing fleet producing a more marked effect on the reduced herd; in 1897 there was found a decrease of 11 per cent. over the preceding year, and during the present season a decrease of 22 per cent. since 1897. The decrease is best shown in the annual counts of seals born on all rookeries small enough to admit of counts being made. These rookeries were, with one exception, on St. Paul Island. A year ago it was not considered feasible to extend the census of pups to any additional rookeries on account of their size. This year it was found that all the rookeries on St. George Island had shrunk to such a degree that actual counts could be substituted for the various estimates hitherto employed. These counts, in connection with those made regularly on St. Paul Island, will be very useful hereafter. Since 1896 the land catch has been: 1896, 28,964; 1897, 20,890; 1898, 18,032. The pelagic catch has decreased as follows: 1894, 61,838; 1895, 56,291; 1896, 43,917; 1897, 24,322. The pelagic catch for 1898 has not yet been made known; but whether less than in 1897 or not, there is no uncertainty about the diminution of the herd.

On account of temporary difficulties, the fences built for retaining males on land were not as strong as they should have been, and many seals escaped. There will be little difficulty in making them perfect next season. Fencing is practicable, and serves the double purpose of preventing the laborious re-driving of non-killables, and keeping them at home during the presence of the sealing fleet in Bering Sea.

Some of the females branded, for the purpose of lessening the value of their skins,

were seen, but young females are not conspicuous about the islands in midsummer.

Certain smooth rookery grounds have been covered with boulders to afford young pups shelter during the battles of the bulls, and attempts will probably be made to repair the injurious worm-infested areas.

A rational scheme of seal ranching is being developed that will practically do away with the moderate natural mortality, and facilitate such handling of the animals as is necessary. Of course, no care of the seals on the breeding grounds will save them, should pelagic sealing continue. The nucleus remaining is sufficiently strong to restore the herd in a few years.

C. H. TOWNSEND.

U. S. FISH COMMISSION.

*THE NATURAL HISTORY MUSEUMS OF  
BRITISH COLUMBIA.*

In proportion to the population and total number of educational institutions, British Columbia has an unusual number of natural history museums. These are exceptionally well administered, considering their isolation from other scientific institutions.

The Provincial Museum at Victoria is by far the most important one in the Province. It is located in the east wing of the Parliament Building, thus having the facilities of the Parliamentary Library. The staff consists of the curator, Mr. John Fannin, a taxidermist and two floor attendants. The Museum was originated some years ago by the government, at the suggestion of Mr. Fannin, whose private collection formed the nucleus of the Museum, after having been the stimulus for its foundation.

As Mr. Fannin's special interest lies in the fauna of the Province, to the knowledge of which he has made important contributions, the trend of the Museum is in this direction, although the other departments of natural history are by no means neglected.

Special attention is now being given to

the building of groups of birds and mammals represented in their natural environments. The interest of the people in this work may be gauged from the fact that Mr. Fannin was sent to the great museums of England and the eastern United States to investigate the methods of preparing such groups.

The policy of the Museum is to be mainly provincial and, while specimens from all parts of the world are used for comparison, the endeavor is thoroughly to represent the natural history of the Province, so that visitors from foreign countries may see at a glance the natural treasures of the region. The collection contains good representation of the birds and mammals of the Province. At present efforts are being made to improve the mountings and secure better specimens of the species.

Fish are represented by gelatine casts and alcoholic specimens. The value of the collection will soon be in proportion to the importance of the fisheries of their coast. There are some specimens illustrating osteology. A considerable collection of crustaceans and shells is also on exhibition, as well as a beautiful series of butterflies and other insects.

This rich mining region is naturally productive of fine mineral specimens, which are represented in the Museum, together with the paleontological collections. Although the Province is excessively rich in anthropological material, its representation in the Museum has been somewhat curtailed from lack of funds. However, there is a fair collection of casts of faces of men; stone, bone and antler implements from shell heaps and mounds; several totem poles, carvings and other ethnological material from the Indian villages of the coast. The implements of hunting and the chase are classed together, as are also the specimens connected with fishing, houses and property, travel, religion, etc.

The Museum is fairly well arranged, and

the labeling will put to shame many of the great museums of the East, although, as with all such institutions, constant improvements are being made.

The city of Vancouver, with a population of some twenty thousand, seems too young to show much interest in the museum as a natural adjunct to education, although the Art and Scientific Society is endeavoring to form a museum in its rooms.

New Westminster, with a population of eight thousand, has made a splendid beginning towards a museum properly connected with other educational affairs. The upper story of the City Library has been set aside for museum purposes.\* Cases have been built from plans furnished by the Smithsonian Institution, and space has been allotted for the various divisions of natural history. There has already been secured and installed a considerable collection of birds and small mammals. Many of these were donated by the Provincial Museum. Several cases have been filled with minerals and other geological specimens. A very few ethnological specimens have been secured; there is more material of an archaeological nature. Some of the stone and bone implements represent rare forms.

The spirit of museum administration exhibited at these institutions is one to be commended. There seems to be no thought in mind to conflict with the plan that the collections are intended for study. Every facility is given to visitors to examine, illustrate or publish papers on any of the material within the museums. It is also understood that full labels are desired. In fact, the spirit shown in these museums is one in close cooperation with research and education.

HARLAN I. SMITH.

AMERICAN MUSEUM OF NATURAL HISTORY,  
NEW YORK.

\*The Library and Natural History Museum of New Westminster were totally destroyed by the fire which consumed that city on September 11, 1898.



## ZOOLOGICAL BIBLIOGRAPHY AND PUBLICATION.\*

THE report presented in 1896 stated that this Committee was issuing two circulars: (I.) Questions concerning general principles of Bibliography and Publication, sent to experts and leading zoologists; (II.) Suggestions concerning various cognate matters 'wholly within the control of editors and publishing committees,' sent to the editors of all publications connected with zoology.

Circular I. has been sent to 115 zoologists, the majority of whom have had practical experience in bibliography. From 36 of these, in various parts of the world, replies have been received, containing, in many cases, a detailed discussion and practical suggestions of much value. A digest of these replies is being drawn up, and the Committee hopes to furnish a definite report thereon next year. Meanwhile certain of the suggestions and criticisms received have greatly helped the Committee in its consideration of the replies to Circular II.

To this latter circular and its strictly practical proposals the Committee thinks it advisable to confine attention for the present. Circular II. has been sent to the editors of nearly all the publications listed in the *Zoological Record*, viz., to some 800, the exceptions being those whose addresses could not be ascertained; it has also been sent to the editors of various publications not hitherto included in the *Zoological Record* list, e. g., all zoological publications recently started.

Replies were not specially solicited, but comments have been received from 39 editors or publishing bodies, to all of whom the Committee desires to express its thanks. Among them may be mentioned: the R. Physical Society of Edinburgh, the Natural

\* Second report of the committee consisting of Sir W. H. Flower, chairman; Professor W. A. Herdman, Mr. W. E. Hoyle, Dr. P. L. Sclater, Mr. Adam Sedgwick, Dr. D. Sharp, Mr. C. D. Sherborn, Rev. T. R. Stebbing, Professor W. F. R. Weldon and Mr. F. A. Bather, secretary.

History Society of Glasgow, the Cambridge Philosophical Society, the Entomological Society of London, the Liverpool Biological Society; *Nature*, *Natural Science*, *The Zoologist*, *The Entomologist*, *The Journal of Malacology*, *Journal of Physiology*, Cambridge; The R. Asiatic Society, Ceylon Branch; K. Akademie der Wissenschaften zu Berlin; K. Zool. u. Anthrop.-Ethnogr. Museum zu Dresden; Zoological Station in Naples; R. Soc. Scientiarum Bohemica; Physikalisch-ökonomische Gesellschaft zu Königsberg; R. Soc. Sciences in Upsala; Société Impériale des Naturalistes de Moscou; Koninklijke Akademie van Wetenschappen, Amsterdam; Geological Society of America, Philadelphia Academy of Natural Sciences, Essex Institute, Cincinnati Society of Natural History, Natural History Society of New Brunswick, *SCIENCE*, *Bulletin of American Paleontology*, *Entomological News*. All these replies are favorable to the suggestions of the Committee in the main, and some even ask for further advice. Exception has, however, been taken by some to suggestions 1, 3 and 7; while comments have also been made on suggestions 2, 4 and 5. It is proposed to deal with these in order.

First, the Committee wishes to state clearly that it has no wish, even if it had the authority, to lay down laws for zoologists or for publishing bodies and editors. It is, however, plain that many are grateful for some guidance, and the Committee hopes that it may serve as a medium for conveying to those who need it the general opinion of the experienced. They are also difficulties which, though they appear to some insuperable, may possibly be surmounted in ways that have been communicated to the Committee.

(1) "That each part of a serial publication should have the date of actual publication, as near as may be, printed on the wrapper, and, when possible, on the last sheet sent to press."

Five correspondents do not see the use of this, thinking that the date on the wrapper is enough, and that in the case of annual publications the date of the year suffices. The Committee would point out that wrappers are constantly lost in binding, and that periodicals are often broken up by specialists or second-hand booksellers, the consequent loss of date causing much trouble to workers of a later day. To avoid this, the Cincinnati Society of Natural History would add the date at the head of each paper, while *Natural Science* prints the month and year across every page-opening. Some societies, *e. g.*, the Philadelphia Academy, issue a certificate of dates at the end of the volume. The Liverpool Biological Society 'put at the head of each paper the date when it is read, and are willing to add the date when it is printed off;' neither of these dates are necessary, and they may be misleading. In most cases the actual day of publication is immaterial, especially in cases where no new species are described, but at least the month should always be given, and the Committee does not see that there need be any difficulty in doing this. If some unforeseen delay does occur, the date can always be rectified with a date-stamp.

(2) "That authors' separate copies should be issued with the original pagination and plate-numbers clearly indicated on each page and plate, and with a reference to the original place of publication."

The Committee believes this to be a most important recommendation, and its view is supported by all the zoologists consulted. Nevertheless, many leading publications continue to issue authors' copies repaged, and often without reference to volume-number, date, or even the name of the periodical. The remedy is so simple that the Committee urgently appeals for its universal application.

(3) "That authors' separate copies should not be distributed privately before the paper

has been published in the regular manner."

It is a curious fact that on this question editors take a different line to working zoologists. All the latter who have discussed the matter agree with the Committee as to the extreme inconvenience caused by the general custom. Among the editors, however, nine (*i. e.*, nearly one-quarter) protest against the present recommendation. The objectors represent small societies which publish at lengthy intervals, and their reasons are: that it is not fair to an author to prevent him from receiving his separate copies for perhaps a year; that it is not to the advantage of science that work should thus be delayed; that a society which did this would receive fewer contributions and lose its members. In brief, the argument is: "We are too poor to publish properly; therefore, we must allow authors to publish improperly." This form of argument suggests an easy remedy, and one that, on the informal suggestion of the Committee, has already been put into practice by the Liverpool Biological Society and by the R. Physical Society of Edinburgh. The remedy is this:

In cases where a volume or part can only appear at long intervals each author that requires separate copies of his paper for private distribution before its publication in the volume or part should be permitted them only on this condition—that, for every month before the probable issue of the volume, a certain number of copies—say five—should be placed by him in the hands of the society or its accredited publisher, in order that they may be offered for sale to the public at a fixed price. Further, that the society, for its part, should announce the publication, with price and agent, of their papers to some recognized office, or to some such paper as the *Zoologischer Anzeiger*. The details of expense must be settled between the author and the society.

(4) "That it is desirable to express the subject of one's paper in its title, while keeping the title as concise as possible."

It is satisfactory to find no objections raised to this recommendation, since there is no doubt that there is room for much improvement in this direction. Such phrases as 'Further contributions towards our knowledge of the \* \* \* \*,' or 'Einige Beobachtungen über \* \* \* \*,' or 'Essai d'une monographie du genre \* \* \* \*,' might well be dispensed with as superfluous. The ornithologist who, in 1895, published a book with a title of ninety-one words would seem to have forgotten the functions of a preface.

On the other hand, it is pointed out that certain periodicals, such as the *Bulletin de la Société Entomologique de France* and the *Sitzungsberichte der Gesellschaft naturforschender Freunde zu Berlin*, publish communications without any title, to the constant confusion of naturalists. The Committee begs to urge the reform of this practice, in which it can see no advantage.

(5) "That new species should be properly diagnosed, and figured when possible."

The only comment on this is the proposed omission of the words 'when possible.' With this the Committee sympathizes, but wishes to avoid all appearance of laying down a law that would constantly be broken.

(6) "That new names should not be proposed in irrelevant footnotes or anonymous paragraphs."

Naturally nobody supports such actions as are here objected to, but since some have doubted the possibility of the latter, it is as well to state that the suggestion was based on an actual case occurring in the Report of a well-known International Congress. The proposal of a new name, without diagnosis, in a footnote to a student's textbook, or in a short review of a work by another author, is by no means a rare occurrence. The Committee believes that

such practices are calculated to throw nomenclature into confusion rather than to advance science.

(7) "That references to previous publications should be made fully and correctly if possible, in accordance with one of the recognized sets of rules for quotation, such as that recently adopted by the French Zoological Society."

Dr. Paul Mayer, of Naples, writes: "Most authors are extremely idle in making good lists of literature themselves, and even opposed my correcting them according to our rules. There ought to be some training in this at our universities." This is confirmed by one or two other editors, but not all have the energy of Dr. Mayer. Some, indeed, oppose the word 'fully' on the ground that it leads to waste of time and space. The Committee would explain that the reference to a particular set of rules was intended merely as a guide to those who have not had the training that Dr. Mayer would like to see; they would also point out, in the words of the editor of the Cincinnati Society of Natural History, that 'what may be intelligible to the specialist is very puzzling to the general student.' Nowadays, when so many zoologists work with the aid of authors' separate copies, it is an enormous convenience to them to have the title of the paper at least indicated, and not merely the volume, date and pagination given. The Committee, therefore, cannot agree that this suggestion involves a waste of time.

#### ASTRONOMICAL NOTES.

SECTION A AT THE BOSTON MEETING, A. A. A. S.

It might be thought that the meetings of the Astronomical Conference and of the Mathematical Society, which preceded that of the American Association and were prolonged so as to interfere somewhat with it, would have detracted from the interest in Section A. While this may have been true in part, it did not reduce the number of the



papers nor their excellence. Forty papers were offered, of which twenty-six were read in full. As two days only were given to meetings for the reading of papers, a subsection was organized on the second day, to which were referred the papers in abstract mathematics. There were also four valuable reports on recent progress, two of which were read before the mathematical subsection and two before a joint session of Sections A and B.

Of the strictly astronomical papers, three were concerned with the teaching of the science; two each with subjects relating to stellar positions, to the work of observatories and to the study of planetary details; and one each with the subjects of photometry, personal equation, variation of latitude and solar eclipses. The short time allowed for these papers, which were all of interest and without exception well presented, prevented their discussion, as there was a perceptible feeling of hurry due to the desire to complete the program. This lack of discussion is to be lamented in scientific gatherings. Fortunately it did not exist at the Conference at Cambridge, where the discussions called out by the papers were a marked feature.

#### THE ASTEROID DQ.

THE discovery by Herr Witt at Berlin, August 13th, of a minor planet whose mean distance from the sun places it between the Earth and Mars is of great interest. It was detected by photography and given especial attention because of its rapid motion. Provisional elements were calculated by Herr Berberich, who has made a specialty of asteroid orbits, and were published in the *Astronomische Nachrichten*. The observations made since their publication show but small departures from the calculated positions, and confirm the substantial accuracy of the provisional orbit. Mr. A. C. D. Crommelin, of the Greenwich Ob-

servatory, published in the *Observatory* for October the results of calculations which assume the accuracy of the first orbit, but which can probably be relied on. As the perihelion distance is 1.13 and the eccentricity 0.23, the least distance of the planet from the Earth is 0.15 (about 14,000,000 miles), while that of Venus is 0.27 and of Mars 0.38. The planet, therefore, comes nearer the Earth than any other planet except the moon, and can be used with great advantage for observations to determine the solar parallax. Its sidereal period is 644.-734 days and its mean synodic period 2.-30692 years. It is approximately 17 miles in diameter and was of the 7th magnitude in 1894. It is surprising that it has not been detected before, but Mr. Crommelin is of the opinion that it has not been introduced into the system by the action of any other planet (the nearest approach to Jupiter is 3.2), but has always been one of the solar family. It will be interesting to learn if the photographs made so abundantly in recent years at Cambridge and elsewhere do not contain it, and undoubtedly they will be examined when the planet's positions in former times are determined.

The Earth passes the longitude of the planet's perihelion January 22d. The next opposition of the planet comes in November, 1900, the perihelion passage occurring February 12, 1901. The opposition in 1894 was a very favorable one, unfortunately lost; another will come in 1924, but that of 1900 will be sufficiently good to warrant careful observations for the solar parallax. In *Circular 34* of the Harvard College Observatory Professor Pickering gives the results of determinations of its brightness. Mr. Wendell's observations with the visual photometer give the mean  $12.13 \pm 0.04$ , which corresponds with the 11.39 at the distance 1. The photographic determination of its brightness is difficult, because an exposure of sufficient length to give any

image at all produces an elongated image, whose intensity is compared with difficulty with the circular stellar image. The photometric magnitude is  $12.70 \pm 0.08$ , which implies, when compared with the visual magnitude, that the color of the planet is redder than that of the comparison stars.

Professor Pickering notes that the planet offers opportunity for the examination of several photometric problems:

"First, the approximate diameter may be determined by comparison with the brighter asteroids and satellites, assuming that the reflecting power is the same. Secondly, the great variation in the distance of this object from the earth will afford an excellent test of the law that the light varies inversely as the square of the distance. The existence of an absorbing medium in the solar system will thus be tested. Thirdly, owing to the proximity of this object to the earth at opposition, its phase angle will vary by a large amount. It will, therefore, afford an excellent test of the law connecting this angle with the variation in brightness which has been found by two or three observers independently."

#### THE ANDROMEDA NEBULA.

SUSPICIONS of change in this nebula have been recently announced, but lack confirmation. Mr. A. A. C. Merlin, British Vice-Consul at Volo, Greece, telegraphed August 29th that a star near the nucleus of the nebula was visible in an 8-inch refractor. This information was not cabled to this country, because observations at Hamburg, Bamberg and Bonn, on August 30th and 31st, failed to confirm the observation. But the *Observatory* for September announced publicly the alleged discovery, and added that observations at Greenwich, August 31st, showed nothing unusual. On September 20th a despatch was sent from Kiel to this country and distributed announcing that "Seraphimoff, of Pulkowa, confirms a

stellar condensation in the center of the Nebula in Andromeda." Photographs at Harvard Observatory on September 20th and 21st, when compared with those taken in 1893, 1894, 1895, 1896, failed to confirm the confirmation, and the evidence of the suspected change seems to be decidedly in the negative.

WINSLOW UPTON.

BROWN UNIVERSITY.

#### ZOOLOGICAL NOTES.

##### ANOTHER SPECIMEN OF NOTORNIS.

FOURTEEN years ago, in referring to the capture of the third living *Notornis*, the great flightless water-hen of New Zealand, the writer took occasion to remark that "it is by no means impossible that other specimens may be added to the three already known, since the localities at which these were taken were some 90 miles apart in a region little known." This expectation has recently been realized and the capture of a fourth *Notornis* is recorded at some length by a correspondent of the *London Times*. The species was based by Owen on some bones, including an imperfect cranium, collected by Walter Mantell so long ago as 1847, and as the remains were associated with those of *Moas* it was naturally supposed that, like them, *Notornis* was extinct. The discovery of a living bird in 1849 showed that fortunately this supposition was incorrect and that this, the largest member of the Rail family, had escaped being 'eaten off the face of the earth by gluttonous man.' It may be said here that Dr. Meyer, and doubtless correctly, considers the fossil and living species of *Notornis* as distinct species, the former bearing the original name *Notornis mantelli*, while the latter is called *Notornis hochstetteri*.

The first living *Notornis* was taken on the shores of Dusky Bay by some sealers who followed its tracks through a light snow, and a second was caught three years later on

Secretary Island, Thompson Sound. Then followed an interval of twenty-seven years without any reliable record of *Notornis*, and it seemed not improbable that the species had at last become extinct, when a third was captured by a rabbit hunter, or rather by his dog, on the eastern side of Lake Te Anau. This specimen was offered in the United States for \$600, and was finally sold at Stevens's famous auction rooms, London, for £110.

The exact locality where the fourth and last bird was found is not given, but it is pretty certain that the species ranges over a considerable extent of wild country and, although probably what may be termed a 'decadent' species, will persist for a while longer.

It is to be hoped that the last specimen has fallen into the hands of some one who will preserve both skin and skeleton, for there is no reason why so large a bird should not be both mounted and skeletonized. The habit of 'keeping the skin and throwing away the characters' of a bird is, however, only too prevalent, and when this is done by professional collectors we can not expect much from others. And this leads to the remark that, when the party dispatched to the Galapagos Islands by Hon. Walter Rothschild obtained four specimens of the flightless and all but extinct cormorant they simply took the skins and failed to preserve a single bone. Considering that the problems of the place of origin and lines of dispersion of the cormorants hinge upon anatomical evidence, such neglect is little less than culpable.

#### ZOOLOGICAL NOMENCLATURE.

IN *The Auk* for October, Mr. D. G. Elliott attacks and Dr. J. A. Allen defends, successfully it seems to us, Canon XL of the Code of the American Ornithologists' Union. This canon states that "the permanence of a name is of far more importance than

its signification or structure.\* \* \* It therefore follows that hybrid names [anagrams, 'nonsense' names and 'barbarous' or 'exotic' names] cannot be displaced. \* \* \* " Why any working zoologist, including under this term paleontologists, should wish to abolish this canon it is difficult to understand, for its removal, or lack of adoption, would open, or does open, the way to countless changes of nomenclature and the creation of hundreds, if not thousands, of new names. And all for no good reason; zoological names are not literature, but simply handles by which species may be grasped, and they serve their purpose equally well if rough hewn or grammatically polished. Le Conte used *Gyascutus* as a generic name simply to illustrate the point that a name need not of necessity have any meaning, and Dr. Leidy coined names with the express statement that they were not etymologically correct, but used because they were shorter than if correctly formed. While it is well when proposing a new name to have it properly formed, there is no reason why long-existing names should be overthrown simply because of some fault in their construction. Possibly most of the readers of SCIENCE are familiar with Professor Walter Miller's paper on 'Scientific Names of Latin and Greek Construction,' published in the Proceedings of the California Academy of Sciences, but the paper deserves to have a wide circulation. F. A. L.

#### CURRENT NOTES ON ANTHROPOLOGY.

##### ANTIQUITIES OF COSTA RICA.

THE last report (March, 1898) of Señor Juan F. Ferraz, Director of the National Museum of Costa Rica, presents in succinct form the condition of the institution, its aims, its regulations and its needs. It is earnestly to be hoped that to the latter there will be a liberal response, as the Museum has done excellent work and is a credit to the State of Costa Rica.



Archæology is a branch which the Museum has always cultivated, and it made an honorable display at Madrid and Chicago. In the present report there is appended a lithograph of a remarkable monolithic inscription on the right bank of the Rio Colorado, province of Guanacaste. It displays two well-known conventional signs for 'man' surmounted by what seems to be the drawing of a tomahawk, and above this an elaborate figure, apparently of a house or other building. A photograph and exact measurements would be most desirable and are necessary for a proper study of the monument.

#### THE BORGIAN CODEX.

This valuable relic of ancient Mexican literature, deriving its name from Cardinal Borgia and preserved in the library of the Vatican, has been recently reproduced in fac-simile by the munificence of the Duc de Loubat. The copies are limited in number and most of them have been presented to institutions. The one I have seen is in the library of the Museum of the University of Pennsylvania.

The Codex makes a book  $10\frac{1}{4}$  inches square, folded in the usual Mexican manner (like a screen), of 74 pages, and is apparently complete. Its contents appear to be the arrangement of the *tonalamatl*, in various sequences, for divining purposes. The grotesque collections of objects indicate the phonetic element of the picture writing, according to the 'ikonomatic' system.

The reproduction is most carefully executed and offers the student all the advantages of the original document.

#### A NEWLY-PUBLISHED AZTEC DOCUMENT.

DR. ANTONIO PEÑAFIEL, already well known for his publications on Mexican archæology, has begun the issue of a 'Coleccion de Documentos para la Historia Mexicana,' with a reproduction, in colors, of the 'Mexican Manuscript, No. 4,' of the

Royal Library of Berlin. It dates from after the Conquest, about 1539, with a text in Nahuatl and Spanish. The colored figures represent the names of places and of persons exhibited by that method of phonetic writing for which I have proposed the term 'ikonomatic' (see my 'Essays of an Americanist,' pp. 213-229). Dr. Peñafiel is not always successful in the analysis of these complex figures. Thus (p. 33) *Tepetoman* was not understood by the native artist as *tepetl*, town, and *comalli*, dish (as Dr. P. says, p. 73), but as *tepetl*, mountain; *co*, in; *matl*, hand; so he drew the picture to represent a hand in, and coming out of, a mountain.

The publication is of much interest to archæologists, and it is earnestly to be hoped that the erudite editor will continue the series.

D. G. BRINTON.

UNIVERSITY OF PENNSYLVANIA.

#### SCIENTIFIC NOTES AND NEWS.

##### THE NATURALISTS AND AFFILIATED SOCIETIES.

THE program of the American Society of Naturalists to be held in New York on Wednesday and Thursday, December 28th and 29th, is as follows:

*December 28th*, at the American Museum of Natural History, at 8 p. m. Address of welcome by the President of the Museum, Morris K. Jesup, followed by a lecture on 'Collections of Fossil Mammals and their Care,' by Professor Henry F. Osborn. At 9:30 a reception to the Naturalists and Affiliated Societies, given by Professor Osborn at his house, No. 850 Madison avenue.

*December 29th*, at Schermerhorn Hall, Columbia University, 12:30-3 p. m., provision will be made for those members who wish to lunch at the University (West Hall). 2 p. m., business meeting of the Naturalists. At 3 the annual discussion on 'Advances in Methods of University Teaching,' by representatives of seven societies, the Anatomists, Anthropologists, Geologists, Botanical Morphologists, Animal Morphologists, Physiologists and Psychologists. At 6:30 an informal session of the Naturalists will be held, pending the annual dinner at 7.

On Friday, December 30th, an opportunity will be given for the members to visit the

Botanical and Zoological Gardens at Bronx Park, New York City. Detailed circulars will shortly be sent out to members by the Secretary of the Naturalists, Dr. H. C. Bumpus, Brown University, Providence, R. I. A local committee has been formed with Professor Osborn, as chairman.

ARRANGEMENTS will at once be made for the meetings of the affiliated societies. It may already be stated that the American Physiological Society and the American Psychological Association will meet on Wednesday, Thursday and Friday, and probably the same days will be chosen for the American Morphological Society, the Society for Plant Morphology and Physiology, and the Association of American Anatomists. The Section of Anthropology of the American Association will meet on Tuesday, followed on Wednesday by the American Folk-lore Society.

THE New York State Science Teachers' Association will, as we have already stated, hold its third annual meeting in New York, in conjunction with the Naturalists, on Thursday and Friday of Christmas week. The opening session will be at 10:30 a. m. on Thursday, and in the afternoon a discussion on science for admission to college will be opened by Professor Davenport, of Harvard University, followed by Professor Bailey, of Cornell University, and other speakers. In the evening the President, Professor Hargitt, of Syracuse University, will make an address, to be followed by a reception on Friday evening. The last session of the Association will be held in the American Museum of Natural History, where Dr. Bickmore will give an address and the exhibits will be opened.

#### THE GERMAN 'NATURFORSCHER UND AERZTE.'

THE seventieth Congress of German Men of Science and Physicians, under the Presidency of Professor Waldeyer, which met at Dusseldorf, beginning on September 19th, was attended by more than two thousand members. Three general addresses were given, an abstract of which we find in the *Naturwissenschaftliche Rundschau*. The first of these, by Professor Klein, the mathematician, discussed the rela-

tion of the German universities to the technical schools. He argued that the university should extend its laboratories and teaching to include technical studies, following here, it appears, the model of the American university. Applied science was further emphasized by the fact that one of the general addresses was for the first time on an engineering subject, and also by the fact that a section of applied mathematics and physics was organized. The third of the addresses was by Professor Tillmann, of Leipzig, on the progress of surgery during the past hundred years.

At the second general session addresses were made by Professor Martius on the causes of illness, in which he argued that the pathogenic microbes were not the true cause, but only the occasion, of illness. Dr. Mendelssohn spoke on the care of the sick and Professor Van't Hoff on the importance of inorganic chemistry. In addition to these two general sessions, there were held combined sessions devoted, respectively, to the sciences and to medicine. In the first of these Professor Krohn spoke on an engineering topic and Professor Pietzker on philosophy and science. Papers were presented before the second group by Professor von Frey, Professor Krehl and Professor Thoma on the heart and the circulation of the blood.

The place of meeting for next year is Munich, and Professor Neumayer, of Hamburg, the eminent meteorologist is President.

#### GENERAL.

THE fiftieth anniversary of the death of Berzelius has been celebrated at Stockholm by a memorial service, at which the King was present. Professor P. Th. Cleve, who holds the chair of chemistry at Upsala, delivered an oration.

DR. O. LOEW, known for his contributions to chemical physiology, has accepted an appointment under the U. S. Department of Agriculture.

THE International Congress of Mathematicians will meet in Paris from 6th to the 12th of August, 1900. The Mathematical Society of France has appointed committees of organization, M. Poincaré being President of that con-

cerned with scientific papers, and M. Darboux with that concerned with the other arrangements.

ON September 20th a general meeting of the German Botanical Society was held, in connection with the Congress of German Men of Science and Physicians. The session was chiefly devoted to memorial notices of members who had died during the preceding year. The record represented a heavy loss to botanical science.

THE annual general meeting of the London Mathematical Society will be held on November 10th. We learn from *Nature* that Lord Kelvin has acceded to the request of the Council, and will be nominated for the office of President. Professor H. Lamb, F.R.S., will be nominated for a Vice-Presidentship. Professor Elliott, F.R.S., has chosen, for the subject of his address, 'Some secondary needs and opportunities of English mathematicians.'

THE *Botanical Gazette* states that Mr. M. A. Carleton is now in Russia, as an agent of the U. S. Department of Agriculture, to study the cereals of the region.

MR. R. H. W. T. HUDSON, of St. Johns College, is this year senior wrangler at Cambridge University. The *Bulletin of the American Mathematical Society* calls attention to the fact that he is the son of Professor W. H. H. Hudson, professor of mathematics in King's College, London.

THE Royal College of Surgeons, of England, has awarded Drs. G. T. Brodie and Cartwright Wood £50 each from a research grant for their investigations. Dr. Brodie is at present engaged on the chemistry of diphtheria antitoxin, and Dr. Cartwright on diphtheria toxins and antitoxins and a method of examining water bacteriologically.

PROFESSOR FOSTER is giving this term at Cambridge University a course of lectures on the history of physiology. The first lecture of the course, given October 24th, was on Claude Bernard.

WE have to record the death of Dr. J. Crocq, professor of pathology in the University of Brussels and a member of the Belgian Senate; of Heinrich Theodor Richter, the metallur-

gist, lately Director of the School of Mines at Freiburg; of Dr. C. G. Gibeli, professor of botany and Director of the Botanical Institute at Turin; of the geographer Francisco Coello de Portugal, in Madrid, and of Dr. B. Kotula, known for his researches on the distribution of plants.

THE Civil Service Commission announces that on November 22, 1898, examinations will be held for the position of statistical field agent, U. S. Fish Commission. The chief subjects of the examination are commercial fisheries and the compilation of statistics. The salary is not given in the notice sent us. Vacancies in the grade of electrical engineer will be filled by examination, on December 3d. One of the vacant positions is in New York, with a salary of \$1,800 per year. The other is at Fort Caswell, with a salary of \$900.

THE International Otolological Congress will meet in the Examination Hall of the Royal College of Surgeons, London, in August, 1898.

THE Eastern Association of Physics Teachers met in Boston on October 29th. The subject for special discussion was the relation of mathematics and physics in secondary schools, papers on which were presented by Professor A. B. Kimball and Dr. Levi L. Conant.

THE Council of the Institution of Civil Engineers of Great Britain have made the following awards, out of the trust funds at their disposal for the purpose, for original papers dealt with during the year 1897-98. The formal presentation took place at the Institution on Tuesday, November 1st, at 8 p. m.: Telford medals and premiums—A. H. Preece (London) and H. C. Stanley (Brisbane, Queensland); Watt medals and premiums—H. L. Callendar, M.A., F.R.S. (London), and J. T. Nicolson (Montreal, Canada); George Stephenson medals and premiums—Whately Eliot (Plymouth), W. O. E. Meade-King (London) and W. P. Marshall (Birmingham); the Crampton prize—E. W. Anderson (Erith); Telford premiums—L. B. Atkinson (Cardiff), Henry Fowler (Horwich), W. L. Strange (Bombay), F. J. Waring, C.M.G. (London), D. W. Brunton (Denver, U. S.), Wilfred Airy, M.A. (London), E. M. Bryant, B.Sc. (Newcastle-on-Tyne), D. B. Butler (London)



and H. V. Champion (Victoria); the James Forrester medal—W. L. Brown, M.Sc. (London); Miller prizes—C. E. Wolff, B.Sc. (Derby), A. D. Keigwin (Ashford), Harold Williams (Kingston), J. T. Morris (London), H. C. Adams (Birmingham), H. O. Eurich (Bradford), B. K. Adams (Colombo), A. B. E. Blackburn (Wendnesbury), Thomas Carter (Newcastle), P. F. Story (Manchester), D. E. Lloyd-Davies (Bewdley) and Wilfred Hall, B.A. (Corbridge-on-Tyne).

At the meeting of the Entomological Society, London, on October 5th, Mr. R. Trimen, the President, announced that the late Mrs. Stainton had bequeathed to the Society such entomological works from her husband's library as were not already in its possession. This bequest was of great importance, and would add to the library a large number of works, many of which, formerly in the library of J. F. Stephens, were old and now scarce.

ACCORDING to the *American Naturalist* the University of California has been presented by the Alaskan Commercial Company, of San Francisco, with the large and valuable collections which the Company has been accumulating for many years. The ethnological portion of the collection is especially rich and doubtless one of the best in existence. The collection also embraces fossil remains of mammoths and many skins and mounted specimens of birds, mammals and invertebrates of the Alaskan region.

THE Anatomical Museum of Cambridge University has received from Professor Flinders Petrie a donation of 19 cases of skulls and bones from his excavations at Hierakonpolis, Egypt. This is the second donation of the kind received from him, and as these include the remains of the pre-historic and earliest dynastic races they are of great value. With this addition the collection of specimens of Egyptian anthropology is thoroughly representative, as it now consists of specimens which represent all the periods of Egyptian history from pre-historic times down to the Battle of Tel-el-Kebir.

THE certified circulation of the libraries of New York City applying for public aid was last year 2,625,142 volumes; the libraries, without exception, showing an increase over the

preceding year. The Astor and Lenox Libraries received, during the year ending June 30th, 27,800 new books, surpassing the accessions of the British Museum. The number of readers was 130,000, as compared with 180,000 in the British Museum.

MR. JOHN CORBETT, formerly M.P. for Mid-Worcestershire, has offered to give £50,000 for founding and endowing a school of agriculture for sons of tenant farmers of the county of Worcestershire.

MR. R. P. COBBOLD, the English traveller, who was arrested in Bokhara by order of the Khan a short time ago, has returned, says the *New York Evening Post*, to Kashmir, having accomplished his journey to the Oxus. Unfortunately, he was obliged to throw away all his luggage, and has thus lost most of the scientific collection which was the primary object of his journey.

CAPTAIN NOVITSKY, of the Russian general staff, has returned from a journey through British India. Though the expedition was for political purposes, he brought back rich botanical and entomological collections, and made valuable meteorological observations.

THE Vienna Academy of Sciences has, according to the *Athenæum*, chartered the Swedish steamer *Gottfried* for its projected scientific expedition to south Arabia. The ship is expected to arrive in a few days at Trieste, where the members of the expedition will go on board. The leader of the party is Count Carl Landberg, the Bavarian Orientalist, who has already spent several winters in the district. Dr. H. Müller proposes to devote his researches to the Sabeen inscriptions and the pre-Arabic archæology.

THREE deaths have now resulted from infection with bubonic plague, contracted in the first instance in Professor Nothnagel's laboratory, where work was being done with cultures of the bacillus brought there from Bombay a year ago by the Austrian Commission. Men of science are fully aware of the danger from such experiments, but do not hesitate to risk their lives for the advancement of knowledge that may prove of inestimable value. The most serious aspect of the case is the evidence given of the susceptibility of Europeans to the plague. The dis-

ease contracted was of the pneumonic form, which is especially contagious and is usually fatal, but the possibility of its extension in Europe has unfortunately been demonstrated. This is not likely to occur at Vienna, where every precaution has been taken to isolate those infected and to destroy all cultures and animals under experiment. But the plague may at any time be imported from the present epidemic centers in India, and may obtain a foothold before it is detected. It will be remembered that the last epidemic of the 'black death' in Great Britain was the great plague of London, in 1665, when 70,000 persons died.

THE Indian government has determined to appoint a special commission, says the *British Medical Journal*, to consist of five members, to conduct investigations regarding the plague. The specific duty of the commission will be to inquire into the origin of the various outbreaks of the plague and the manner in which the disease is spread. An official statement also is required as to the efficacy of the serum treatment and the prevention of plague by means of inoculation. So far as the nominations on this commission have been made public, two Indian civilians, Messrs. J. R. Sewwett and A. Cumine, have already been appointed, but it is understood that three other members will be nominated by the Secretary of State for India to proceed from this country, of whom one will act as chairman, while two will be experts. There is plenty of work for the commission to do. Plague, as Dr. Simpson in his address at Edinburgh stated, has demonstrated the absolute necessity for a trained sanitary service for India, and, although the intended commission may work out the scientific bearings of the epidemic of plague, it must be remembered that plague is but one of the epidemics which ever threaten India. Plague is but an expression of the general insanitary state, and any governmental inquiry which does not deal with the general relief of the insanitation of India will but touch the fringe of the evil. A sanitary service, complete in all its branches, administrative, investigative and scientific, is required in India.

THE Harveyan oration was delivered at the Royal College of Physicians on October 18th by

Sir Dyce Duckworth. According to the report in the *London Times*, after urging the claims of the College to the consideration of generous benefactors, he pointed out that Harvey had definitely charged them to encourage research. What were greatly needed now in England were research laboratories attached to hospital wards and *post-mortem* theatres, and also a select staff of fully-trained investigators available for service throughout the Empire. It was surely humiliating that researches were permitted to be made for the public benefit in various parts of British territory by foreigners, while many of their countrymen and countrywomen, owing to ignorance and mawkish sentimentality, were doing their best to debar the training of such men in England. After alluding to the results of recent pathological research in regard to the preventive treatment of tuberculosis, Sir Dyce Duckworth observed that the Röntgen rays have as yet yielded little new information, and their therapeutic influence was not determined, but according to Rieder, of Munich, the rays emitted from high-vacuum tubes killed bacteria. The influence of glycerine in destroying some of the most noxious microbes which gained access to ordinary vaccine lymph was very noteworthy, and he could not but imagine that this agent might yet be found of more extended usefulness as a bactericide. Expressing his private opinion, though he believed it to be shared by the majority of those he addressed, he did not hesitate to stigmatize the recent Vaccination Act as a piece of panic legislation, a lamentable concession to ignorance, fraught with serious peril to the whole community, and unworthy of the duty and dignity of any British government. He closed with a brief appreciation of Harvey's chief scientific achievements, and of his great guiding principle, devotion to truth.

THE office of Regents of the University of the State of New York calls attention to the fact that the last few years of this century are witnessing greater activity in building and equipping medical schools than any other period. At no time in New York State history has so much been done as within the past few years to advance the interests of medical education. The advanced requirements for license, instead

of causing any hardship, have been accompanied by extraordinary growth in the property of New York medical schools. The report for 1897 showed an increase since 1893 of more than 100 per cent. in total property, and of nearly 100 per cent. in annual receipts. Since that time even this great increase has grown still larger, especially in Greater New York. The University and Bellevue Hospital Medical College has the fine new building erected in 1897 by the Faculty of the Bellevue Hospital Medical College. The College of Physicians and Surgeons, with the Vanderbilt Clinic, doubled in size by the additional gift in 1895 of \$350,000, and the Sloan Maternity Hospital, greatly enlarged in 1897, now make the most complete plant in existence for scientific medical education. The Polhemus Memorial Clinic has been completed and thoroughly equipped since the last report, providing accommodations for the out-patient and medical school departments of the Long Island College Hospital. The intention of Mrs. Polhemus, that everything pertaining to the construction and equipment of this building should be of the most approved type, has certainly been carried out. Through the medical division of the Flower Hospital, opened in 1896, the New York Homeopathic Medical College now gives an excellent opportunity for the study of practical medicine. The New York Medical College and Hospital for Women has just opened its handsome new building in West 101st street. Last, but not least, \$1,500,000, the greatest amount ever devoted by one person at one time to purposes of medical instruction, has just been given to build, equip and endow the new medical department of Cornell University in New York City.

THE *Annales d'oculistique*, as quoted in the London *Times*, reports an important decision on 'Scientific Criticism of Proprietary Articles,' given in March last by the civil tribunal of the Department of Seine-Inférieure. The time during which an appeal might be lodged having elapsed, it has now become an expression of the French law upon the point. The question arose in an action for damages, to the extent of 20,000 francs, brought by a firm of opticians in Paris against Dr. Javal, the Director of the Ophthalmological Laboratory of the Sor-

bonne. The plaintiffs were the proprietors of a glass containing baryta, from which they manufacture spectacle lenses, which were described as 'isometric,' and were extensively advertised as possessing special excellencies. Dr. Javal instructed two of his assistants, MM. Durault and Tscherning, to institute a careful examination of the glass and of the lenses made from it, and to report fully to him upon the subject. They carried out his instructions, and reported that the differences between baryta glass and ordinary glass were insignificant; that they were not in favor of the former, and that the 'isometric' lenses did not offer any advantages to purchasers. Dr. Javal published this report by presenting it to the French Academy of Medicine, and hence the action. The Court decided that a scientific man might rightly examine and criticise, on public grounds, any manufactured article for which special merits were claimed, and they found for the defendant upon all the issues, condemning the plaintiff in costs. The decision has been received with much satisfaction by the medical profession in France, and the liberty thus secured is likely to be employed with reference to many pharmaceutical preparations and alleged remedies.

THE Annual Congress of the Sanitary Institute of Great Britain was opened at Birmingham on September 17th with an attendance of 800 members. In his presidential address, as reported in the *British Medical Journal*, Sir Joseph Fayrer surveyed the progress of preventive medicine or hygiene during recent times. In bringing about that progress the Sanitary Institute had taken an important part. He described the conditions under which the people lived fifty years ago, and contrasted them with the present conditions. Upwards of 200 millions had been spent on sanitary work with great benefit to the public health. Popular teaching and example and the general diffusion of education were still necessary in order to convince the proletariat of what so intimately concerned their vital interests. It would perhaps not be until the more complete organization of the public health administration under a Minister of Public Health were effected that the full benefits of sanitary legislation would be realized, and the people attain to that standard of health



and duration of life for which they had a right to hope. He showed the effect of hygienic measures upon certain well-known diseases, and with regard to vaccination he said the evidence seemed to show that there could be no doubt as to its value. As to the methods by which every individual was to be vaccinated or revaccinated, that was a subject for the State to determine. That the Acts in existence up to the present time were inadequate to this end was plainly shown by the fact that large and increasing numbers of the population were known to be unvaccinated, despite the compulsory character of the Acts. The most recent Vaccination Act, whatever might be its advantages, was certainly defective in this—that it made no provision for revaccination, the necessity for which was universally admitted by the medical profession, whilst it was very doubtful whether the modification of the compulsory clauses would have the effect, as it was hoped, of extending vaccination. The scope and aim of sanitary science in its preventive aspects should not be limited to the consideration of zymotic and other acute diseases, but should extend to the results of abnormal social conditions arising out of the strain and struggle for existence, involving over-competition in various occupations by which life was supported or wealth and distinction acquired, and under the pressure of which so many lost their health or even succumbed. He quoted from the Registrar-General's returns to show the influence exerted on vital statistics by sanitary science. He dwelt at some length upon the beneficial results of sanitary work in India, and concluded by saying that evidently a great future was before preventive medicine, and they might confidently look to the eminent men of science who were now pursuing with such indefatigable zeal their researches into the mysteries of bacteriology for its fulfillment. But those who admired and appreciated their work the most and looked forward hopefully to its results were anxious that progress should not be retarded by hasty deduction and premature generalization, which might only end in disappointment, however great might be the importance of the study of bacteriology and the various conclusions resulting from it.

#### UNIVERSITY AND EDUCATIONAL NEWS.

By the will of the late Dr. Albert S. Hunt the sum of \$30,000 was bequeathed to the Wesleyan Library as a permanent endowment fund. The University received also Dr. Hunt's own library of 5,000 volumes. Dr. Hunt was graduated from Wesleyan University in 1851.

MR. W. C. MACDONALD has given a further sum of over \$25,000 to the electrical department of McGill University, Montreal.

TRINITY COLLEGE received a donation of \$10,000 by the will of the late Nathan Warren, of New York.

AT the annual meeting of the Governors of University College, Liverpool, on October 15th, the Earl of Derby, President of the College, stated that the most pressing needs of the institution were a building for the department of physics and one for the department of human anatomy. The latter would cost about £20,000, and towards this sum the Earl of Derby subscribed at the time £5,000 on condition that the balance be collected. Mr. Ralph Brocklebank subscribed £2,000.

PRESIDENT SCHURMAN has presented his sixth annual report to the Board of Trustees of Cornell University. Reference is made to three important benefactions that we have already recorded; the gift of an infirmary, richly endowed; the establishment of a New York State College of Forestry, supported by the State and administered by the University; and the foundation of the Cornell Medical College, in New York City. The following figures are given concerning the financial affairs of the University:

Value of buildings and grounds.....	\$1,796,372 86
Equipment of departments.....	1,135,308 12
Invested funds.....	6,446,818 21
Total property.....	9,378,499 19
Receipts from tuition.....	121,205 83
Total income.....	583,050 73
Total expenses.....	570,586 36
Salaries.....	286,185 72

The number of regularly enrolled students was 1,835.

THE registration in the various departments of the University of Michigan, on October 25th, is indicated in the following table. The cor-

responding figures for October 25, 1897, are also given:

	1887	1898
Literary department . . . . .	1276	1254
Engineering department . . . . .	269	245
Medical department . . . . .	425	407
Law department . . . . .	710	713
Dental department . . . . .	218	230
Homoeopathic department . . . . .	59	60
Pharmaceutical department . . . . .	76	73
	3033	2982

THE attendance in Oberlin College shows a falling off of nearly one hundred, the figures to date being 1,040 as compared to 1,135 last year. The increase in tuition may account for part of the loss. Tuition now is placed at \$75.00 per year.

DR. JOHN GUIERAS, professor of pathology in the University of Pennsylvania, will resign at the close of the present year to accept the chair of the practice of medicine at the University of Havana. Dr. Guieras has been greatly interested in the liberation of Cuba and wishes to build up the medical courses in the University of Havana.

C. E. MENDENHALL, PH.D. (Johns Hopkins), has been appointed instructor in physics in Williams College. Dr. J. C. Hardy has been appointed instructor in mathematics in the same institution.

THOS. CLARKE, B. S. (University of N. C., '96), Ph.D. (Bonn, '98), has been appointed assistant in chemistry at the University of North Carolina.

AMONG foreign appointments we note that Dr. Frenzel has been promoted to a professorship in the Agricultural College at Berlin and Professor Wälsch to a professorship of mathematics in the Technical Institute at Brünn. Dr. H. E. Ziegler, of Freiburg, i.B., has been appointed successor of Professor Kückenthals, 'Ritter' professor of phylogeny in the University at Jena; Dr. E. Reinbach, of Berlin, professor in the Chemical Institute at Bonn, and Dr. Fenner, of Aix, professor of geodesy in the Technical Institute at Darmstadt. At Vienna, Dr. Zukal has been made professor of phytopathology in the Agricultural College, and Dr. Ritter Lorenz V. Liburnau has qualified as

docent in zoology; in the University Dr. Werner has qualified as docent in zoology, and Dr. Reithoffer in technical electricity.

#### DISCUSSION AND CORRESPONDENCE.

##### MEASUREMENTS OF PRECISION.

AN article in the *Physical Review*, September-October, 1898, by S. N. Taylor, should not be overlooked by those who are interested in knowing the degree of precision which may be reached in linear and other measurements.

The paper itself should be consulted, but a few of Mr. Taylor's most remarkable accomplishments may be mentioned here. It comes in his way to measure several diameters of a coil of wire, consisting of fifteen layers, with fifteen turns in each layer, the mean diameter of the coil being about 20 cm., and the wire being *No. 18, copper, double-silk insulated, passing through a bath of hot paraffine during the process of winding.*

It is wound upon a cup-shaped cylinder of plaster of Paris, which was soaked in a mixture of linseed oil and liquid dryer sometime before its use. Mr. Taylor tabulates his measurements of these diameters, each layer, as it is wound on, in figures carried to *thousandths and ten thousandths of a millimeter*, thus implying that his measures are made to one part in two millions.

They are made, he says, by means of a cathetometer, before which the coil is mounted on an axis, that it may be turned into six different positions. Unfortunately, he does not say how far the coil was from the cathetometer, or give the name of the maker of an instrument of a type so extraordinary as to justify these figures on the diameters of a wire coil. Still more unfortunately, he fails to give the results of several independent measurements in each position, which he says were taken.

A thousandth of a millimeter is always worth struggling for, and, as a variation of a single degree in the temperature of his cathetometer bar would probably change its length by 15 or 20 of them, it is to be inferred that highly perfected methods of determining that temperature were used, although the author is also silent on that point. The level on the cathetometer

telescope must have been an uncommonly sensitive and well-behaved attachment, the name of the maker of which should not be concealed. It cannot be that these measurements are in any degree doubtful, for, otherwise, Mr. Taylor would hardly use them, as he has, in computing the constant of his instrument, in which operation he carries results to eight significant figures, the unit of the last place in his final mean standing for about *one part in thirty millions*. A 'sudden drop' is experienced, however, in the very next paragraph, where he says that the same calculation has been made by other people and by a different method, resulting in a quantity differing from the former by about one part in five or six hundred, and which he proceeds to use instead of the result of his own labors.

But it is not in linear measurement alone that marvelous skill is shown in this piece of work. There is weighing which must also excite admiration. A movable coil of the same kind of wire, which must have weighed not much less than a kilogram, was suspended from the arm of a balance; and the 'pull' on this coil, amounting, it is inferred from the tables, to about 23 grams in one case and about 45 grams in another, was weighed to within one-tenth of a milligram. This, of itself, is not, perhaps, remarkable, but it becomes so when it is remembered that this coil is anchored to solid ground by two thin slips of 'crimped' sheet copper, 7 mm. in width. The getting of a tenth of a milligram under such conditions implies rare skill. But the reader is again doomed to bitter disappointment when he is informed that the result of all this exquisite work is to give a value for the E. M. F. of a Clark cell differing from all of the many good determinations that have been made before by more than one part in two hundred and fifty or nearly one-half of one per cent., and that the author himself concludes that, as absolute measurements, his results 'don't count.'

'Figuratively speaking,' Mr. Taylor's paper is, or ought to be, almost unique, but it is only justice to him to add that it really contains much that is interesting and valuable from points of view other than that of metrology.

X.

#### LIFE-ZONES IN NEW MEXICO.

A NEW bulletin by Dr. C. H. Merriam has just come to hand from the Department of Agriculture, entitled 'Life-Zones and Crop-Zones.' It contains a colored map showing the zones, and a great deal of valuable information about the agricultural products of each zone. On p. 13 it is stated:

"The colored maps prepared by the Biological Survey furnish the first rational basis the American farmer and fruit grower has ever had for the intelligent distribution of seeds and the only reliable guide he can find in ascertaining beforehand what crops and fruits are likely to prove successful on his own farm, wherever it may be located."

On p. 7 it is stated that "great care has been taken to make the lists accurate and trustworthy as far as they go." Also, "the intention in the present report is to omit doubtful records."

On p. 42 we find these words: "Raisins and wine grapes, oranges, lemons, olives, prunes, peaches, apricots, English walnuts and almonds are among the important products of the Lower Sonoran area, and the fig ripens several crops each year." Immediately following is a list of the crops of the Lower Sonoran, including even guavas and the loquat, among a variety of other things.

On p. 41 it is said that the Lower Sonoran "sends an arm northwest to a point a little north of Albuquerque, New Mexico. Another arm reaches up the valley of the Pecos." The map shows these arms, the Pecos valley one going about to Eddy. These arms are colored as typical Lower Sonoran, and no word appears in the text to suggest otherwise.

On pp. 15-17 the special value of these arms is insisted upon, because "by growing particular crops at points remote from the usual sources of supply, and at the same time conveniently near a market, the cost of transportation is greatly reduced and the profit correspondingly increased."

After all this, the reader will be surprised to learn that heavy frosts occur annually in the supposed Lower Sonoran arms in New Mexico, and that the cultivation of oranges, lemons or olives is totally out of the question anywhere within the bounds of the Territory. The fig,



so far from ripening several crops annually, is killed down every winter, except in sheltered places, as between four walls, and does not produce any crop unless thus protected. In short, the products of the Rio Grande and Pecos valleys in New Mexico are *Upper Sonoran*, not *Lower Sonoran* at all, although it is true that there are some elements in the fauna and flora which may even be called neotropical.

These facts are not new, nor is this criticism of Dr. Merriam's map here made for the first time. In the plainest possible language, I drew attention to the real status of the case in Bull. 15, of the N. M. Experiment Station, January, 1895, pp. 54, 55. Again I protested against Dr. Merriam's mapping in Bull. 17 of the same station, April, 1896, p. 100. Still again the subject was discussed in Bull. 24 of the same station, August, 1897, p. 7, etc. In the publication last cited are quotations from an excellent letter by Dr. T. S. Palmer, of the Biological Survey, admitting that the products assigned to the *Lower Sonoran* do not grow all over that area as mapped; but in the work now criticised there is no hint of this.

Professor C. H. T. Townsend, who has long studied the distribution of life in New Mexico, has also expressed himself clearly and explicitly on the point at issue. He further explains the limits of the *Lower Sonoran* in Arizona, Mexico and Texas, on pp. 84, 85 of his paper in the Proceedings of the Texas Academy of Science, vol. 1. In a second paper in the same Proceedings he has further discussed the fauna and flora of Mexico and the southwestern United States, giving many new facts and arguments.

Neither Professor Townsend nor the present writer imagine that we are within a measurable distance of reaching final conclusions on zonedistribution in the West; but the facts mentioned above, ignored by Dr. Merriam, are matters of common knowledge to every inhabitant of this region. Certain persons interested in the sale of lands have from time to time circulated false statements as to the products of southern New Mexico, which statements have been duly corrected. But now, for their most extravagant assertions, they can fall back on the authority of the Chief of the Biological Survey!

We all owe thanks to Dr. Merriam for the

large amount of extremely valuable work he has accomplished during the last ten years, but this fact cannot protect him from criticism when he deliberately reissues misleading statements and maps, totally ignoring the protests of those who are working in the region discussed. He not only perpetuates a scientific error, but runs the risk of seriously misleading those farmers whom he invites to guide their operations by his aid.

T. D. A. COCKERELL.

MESILLA PARK, N. M.,  
September 22, 1898.

MR. COCKERELL finds fault with me for including certain parts of the valleys of the Rio Grande and Pecos in the *Lower Sonoran Zone*, and makes the positive statement that they are in the *Upper Sonoran Zone*. At the same time he admits that the faunas and floras of these valleys are mixtures of at least two zones. In this I quite agree with him. He considers the preponderance of species *Upper Sonoran*; I considered it *Lower Sonoran*. The difference between us, therefore, relates to the position of the boundary line—a line separating adjoining belts in a narrow valley. He thinks I have carried it too far north. He may be right. But he omits to quote from my Bulletin an important statement intended to cover this class of cases. In discussing the northern arms of the Carolinian faunal area I said: "These arms, like nearly all narrow northward prolongations of southern zones, do not carry the complete faunas and floras of the areas to which they belong, but lack certain species from the start and become more and more dilute to the northward till it is hard to say where they really end. Their northern boundaries must be drawn arbitrarily, or must be based on the presence or absence of particular species rather than the usual association of species."

This seems to dispose of the main point of Mr. Cockerell's criticism. The absurd claim that all the crops mentioned as growing in a particular zone will grow in all parts of that zone has never been made by me. And as to the map, it seems hardly necessary to say that one on so small a scale as that accompanying the paper in question can hardly be expected to

show the degree of purity and extent of overlapping of contiguous parts of adjoining belts.

In conclusion, I beg to express the hope that my protracted absence in remote parts of the West, while engaged in tracing the boundaries of the life zones, may ameliorate my offense in not having seen all of Mr. Cockerell's writings.

C. HART MERRIAM.

SAN FRANCISCO, CAL., October 11, 1898.

#### SCIENTIFIC LITERATURE.

*Angewandte Elektrochemie.* Zweiter Band: Anorganische Elektrochemie. Dritter Band: Organische Elektrochemie. Von DR. FRANZ PETERS. Hartleben's Verlag, Wien; Pest, Leipzig.

The first volume of this book was reviewed in SCIENCE by Professor Smith (April 9, 1897). In the light of this notice of the general purport of the book by so able an authority, attention need only be called to the appearance of the subsequent volumes and to their contents. The second volume, on the electro-chemistry of inorganic substances, is divided into two parts. The first deals with the electro-chemistry of the metalloids and alkali metals, including methods of obtaining hydrogen, of purifying water, of obtaining chlorine, bromine and iodine, oxygen and ozone, arsenic and antimony. It is interesting to note under carbon that it volatilizes at about 3,600° in the arc of the electric lamp, and that Moissan has succeeded in converting it into vapor in the electric furnace. It did not, however, assume the liquid state, but passed at once into vapor. The beautiful work of Moissan on highly heated carbon is taken up at some length. The electrolytic separation of lithium and sodium is then taken up, the methods of Grabau, Borschers and Castner in the production of sodium receiving special treatment.

The second part of the second volume is devoted to the alkaline earths, the earths and heavy metals.

The third volume deals entirely with the electro-chemistry of organic compounds. The extent to which organic compounds can be prepared by the action of the current is shown by the number of classes of substances included in this volume. In the paraffin series there are

thirteen classes, including hydrocarbons, alcohols, ether, ethereal salts, acids. In the aromatic series there are seventeen classes, including hydrocarbons, nitro, sulphur and amine derivatives of the hydrocarbons, phenols, alcohols, aldehydes, ketones and acids. This volume closes with an account of some of the practical uses of organic electro-chemistry, as electrotyping, electroprinting, electroplating, etc.

Insofar as it deals with the electrolytic deposition of the metals, this book covers some of the same ground as the well known work of Borschers, which deals with electro-metallurgy in such a masterly manner. But the work of Peters covers a much wider field, and will doubtless prove to be a valuable contribution to practical electro-chemistry.

H. C. J.

*Up-to-date Air-brake Catechism.* By ROBERT H. BLACKALL, Air-Brake Inspector and Instructor on the D. & H. Ry. New York, N. W. Henley & Co. 12mo. Pp. 230. Illustrated.

This is a little book, but one of great value in a special field. It is the custom of the makers of air-brakes, and of the management of the best railway systems, to employ an inspector and instructor to go from point to point on the railways, inspecting the brake outfit and teaching its use, as experts. The plan is an admirable one and undoubtedly a most valuable insurance of safety to the traveling public as well as to employees. Mr. Blackall is one of these instructors and inspectors who, with rare discretion, tact and expert knowledge, has written out his instructions in this catechetical form and printed it.

The book is not only unique in its subject, in its completeness and in its comprehensiveness; but it is one which evidences in its plan, in its literary form and in detail, the talent and culture of a man of education, as well as of professional competence. Before January 1, 1900, every train must have sufficient air-brake equipment to control it, and this means the education and training of an army of railroad men of all grades; hence the value of this timely text-book. It includes a discussion of

the details of the equipment, their usual defects, accidents, shortcomings, and methods of remedy, as well as of their every-day management. It is an admirable bit of very useful book-making, and its notice in this place is entirely justified by its scientific character and completeness, as well as by its intrinsic value in its place and for its purpose.

R. H. T.

#### SCIENTIFIC JOURNALS.

THE *American Naturalist* for October opens with an article by Mr. John Murdoch, describing the relation between the Eskimos of Port Barrow, northwestern Alaska, and the animals of their country. Mr. G. W. Field's article on methods of planktology describing work carried out in The Rhode Island Experiment Station is reprinted from the Report of the Station. Mr. C. R. Eastman discusses some new points in Dinichthyid Osteology, and Professor Comstock and Dr. Needham continue their treatise on the wings of insects. There is a note on the variation of the teleutospores of *Puccinia windsoria*, by Mr. J. A. Warren, and editorially the plans for a marine biological station in Canada are discussed. Thirty-four pages are devoted to reviews of literature and scientific news.

*Terrestrial Magnetism* for September is almost entirely devoted to the recent International Conference on Terrestrial Magnetism and Atmospheric Electricity, reported in a recent issue of SCIENCE. A full account of the proceedings of the Conference is given, likewise the words of welcome addressed to those attending it by the President of Section A, Professor W. E. Ayrton, and the opening address of the President of the Conference, Professor A. W. Rücker. The following papers presented to the Conference are printed in full:

Establishment of Temporary Magnetic Observatories: W. von Bezold and M. Rykatschew.

Relative Advantages of Long and Short Magnets: E. Mascart.

Questions to be addressed to Magnetic Observatories: M. Eschenbagen.

Systematische Erforschung der Saecular Variation: A Schmidt (Gotha).

Magnetic Observations in the Azores: Albert, Prince of Monaco.

Mouvement diurne du pôle nord d'un barreau magnétique: J. B. Capello.

Expression of the Earth's Magnetic Potential: A. Schuster.

Earth Currents, Atmospheric Currents and Magnetic Perturbations: S. Lemström.

Interpretation of Earth Current Observations: A. Schuster.

Magnetic and Electrolytic Actions of Electric Railways.

#### SOCIETIES AND ACADEMIES.

ENTOMOLOGICAL SOCIETY OF WASHINGTON,  
OCTOBER 20, 1898.

UNDER the head of short notes and exhibition of specimens Mr. Pratt exhibited a specimen of *Phyciodes tharos* which had been taken at electric light at night. Mr. Schwarz showed a dry flower stem of the bear-grass showing the work of the Buprestid beetle *Thrinopyge ambiens* Lec., the single stem indicating the entire life history of the beetle, which works in the center and does not appreciably injure the plant. Some discussion followed upon the bear-grass and the allied Yuccas and Dasylirions of the arid region, more particularly in regard to the destruction of flower pod by cattle in spite of the especially protective growth. Mr. Heidemann showed three species of *Aradidæ* new to the District of Columbia, viz., *Aradus crenatus* Say, *A. breviatus* Bergr. and *A. inornatus* Stål., with comments upon their habits and characters. He also showed specimens of *Calisius pallices* Stål., from Florida, a species hitherto known only from South America and which must now be added to the fauna of boreal America. Mr. Ashmead remarked that he had found this last species under the bark of dead orange trees killed by frost. Mr. Howard called attention to an outbreak of the chinchbug upon the lawns in the city of Brooklyn during the months of July and August last, pointing out that the sudden appearance of this insect in enormous numbers in the center of a densely populated city, hundreds of miles from any previous point of destructive appearance and in the middle of a summer characterized by excessive precipitation and upon closely-cut lawns which had been frequently watered, afforded an instance entirely unprecedented in the history of the species.



Dr. Dyar read the first paper of the evening, entitled 'Notes on Acronycta and their Larvæ,' in which he spoke of a forthcoming work on these insects prepared by himself and Dr. J. B. Smith. He called especial attention to the fact that his own classification of the group from the larvæ coincided in a remarkable manner with Dr. Smith's classification of the group derived from the study of the adult characters only. He showed that the larvæ may be divided into three main groups, and illustrated his remarks by the exhibition of specimens.

Mr. Schwarz presented a communication on the insect fauna of southern Arizona. The aquatic and riparian insect faunas are well represented, but do not offer any distinguishing features in their mode of appearance or development. In many rivers and most of the creeks the water sinks below the surface of the ground for a longer or shorter period during spring and early summer, and in this period the insect fauna—imago and larvæ—follow the moisture underground and remain dormant until the advent of the July and August rains. There is a small but interesting winter flora and fauna in southern Arizona, as exemplified by the canaigre plant (*Rumex hymenosepalus*) and the various insects infesting the same. Both the plant and the insect retire underground in February and remain dormant until the following October. The great increase of temperature from April until the end of June has but little influence upon the development of insect and plant life, and the insect fauna at this season is comparatively poor in species. By far the greater portion of insects, and among them the most characteristic species, do not appear before the beginning of the rainy season in July. Their appearance is governed not by the increase of temperature, but by the increase of humidity.

L. O. HOWARD,

Secretary.

THE NEW YORK SECTION OF THE AMERICAN  
CHEMICAL SOCIETY.

The regular meeting of the New York Section of the American Chemical Society was held last Friday evening at the College of the City of New York, with an attendance of fifty-one members, Dr. Wm. McMurtrie presiding.

An informal report was made as to the progress in organizing a chemical club, in which it was stated that the matter is in the hands of a committee of which Dr. C. F. Chandler is chairman, and the subject is being actively canvassed.

The question of inviting the Society at large to hold the mid-winter meeting in New York was then taken up for discussion, and on final motion the vote was unanimous in favor of it, and committees of arrangements were ordered appointed.

The death of Dr. Bromwell was then announced and a brief sketch of his career presented.

The following papers were read :

(1) Aug. E. Kuorr, 'An Extraction Apparatus with a Novel Accessory.'

(2) Albert C. Hale, 'A Statement of the Work accomplished at the General Meeting of the Section in Boston.'

(3) William McMurtrie, 'Some Records of the Year's Progress in Applied Chemistry.'

Dr. Hale stated that the membership of the Society is now 1,378; that of the Section 285, and that of the recently organized New England Section is already over 200, the new members elected since September 1st numbering about 60. The growth of the Boston Section has been phenomenal, and it is already one of the strongest.

Dr. McMurtrie's review of 'Progress in Applied Chemistry' was full of interesting material and could well have been divided between two or more meetings, with time for digestion and discussion.

The next meeting of the Section will be held on the 11th of November, at which it is expected that a well known expert in the chemical technology of glass-making will be present and will read a paper.

DURAND WOODMAN,  
Secretary.

ENGELMANN BOTANICAL CLUB.

The Club met at the St. Louis Medical College on Thursday, September 22d.

Mr. C. H. Thompson presented some brief notes on the pollination of the species of *Thalia* native to the United States. In his study of the

flower structure, together with observations upon plants grown in the water gardens of the Missouri Botanical Garden and Tower Grove Park, he finds they are especially adapted to the visits of large bees. The flower is so constructed as to utilize these visits in effecting cross-pollination. The pistil is held under tension in a manner similar to the bowed stamens in *Kalmia* by one of the lower staminodia. This staminodium is folded about the pistil in much the same way that the keel of a papilionaceous leguminous flower surrounds the stamen column, though much more closely and tenaciously. One margin of the keel develops two bristles, the posterior of which is in the direct path to the nectary. This bristle proves to be highly sensitive, and transmits an impulse to the part of the keel clasping the pistil, allowing the latter to suddenly rise and coil in a spiral motion. Before the flower opens the anther cell dehisces and sheds its pollen on a viscid disc which is situated on a style immediately back of the stigma. The stigmatic surface itself forms a funnel-shaped excavation in the end of the pistil. When a bumble-bee alights on the broad petaloid staminodium which forms the platform of the flower it thrusts its beak directly forward, under the canopy-shaped upper staminodium, into the drop of nectar which is clearly visible. By this act the beak strikes the sensitive bristle, which in turn releases the pistil. This rises with a sweeping, spirally-coiling motion which brings the stigmatic surface in contact with the base of the bee's beak, scraping into it any pollen that may have been previously deposited there. Then in its further motion the pistil deposits more pollen, from the viscid disc, upon the bee's beak at the same spot previously scraped by the stigma. This is to be carried to another flower. Finally the pistil comes to rest with its stigma snugly buried in a little wall pocket formed by a fold of the inner surface of the upper staminodium, thus excluding any possibility of further deposits of pollen upon it. Immediately this takes place the petaloid staminodia begin to wither and so discourage any further visits of insects.

A discussion of the flora about Crève Coeur Lake followed.

The Club met again on Thursday, October

13th, fifteen members present. Mr. J. B. S. Norton discussed the modes of branching found in Euphorbiaceae, and explained the structure of the flower, illustrating his remarks with numerous specimens. Miss N. M. Gladfelter spoke on edible mushrooms, and exhibited some forty species collected in and about St. Louis on one afternoon. Professor W. R. Dodson reported upon some results of growing soy beans of different colors. By selection it was possible to reach two extreme forms as well as all of the intermediate stages.

HERMANN VON SCHRENK,  
Secretary.

#### NEW BOOKS.

- Elementary Botany.* GEORGE FRANCIS ATKINSON. New York, Henry Holt & Co. 1898. Pp. xxiii + 444. \$1.25.
- Text-book of Algebra.* GEORGE EGBERT FISHER and ISAAC J. SCHWARTZ. Philadelphia, Fisher & Schwartz. 1898. Part I. Pp. xiii + 683.
- The Ice Age, Past and Coming.* C. A. M. TABER. Boston. 1898. Pp. 101.
- The Genesis and Dissolution of the Faculty of Speech.* JOSEPH COLLINS. New York and London, The Macmillan Company. 1898. Pp. 432.
- Elements of Sanitary Engineering.* MANSFIELD MERRIMAN. New York, John Wiley & Sons; London, Chapman & Hall, Ltd. 1898. Pp. 216. \$2.00.
- L'Année biologique.* 2d year, 1896. IVES DELAGE. Paris, Schleicher Frères. 1898. Pp. xxxv + 808.
- Nature Novitates.* Berlin, R. Friedländer und Sohn. 1898. Pp. 683. M. 4.
- Wild Animals I have Known.* ERNEST SETON THOMPSON. New York, Charles Scribner's Sons. Pp. 359. \$2.00.
- Organographie der Pflanzen.* 2d vol., Specielle Organographie; 1st part, Bryophyten. K. GOEBEL. Jena, Gustav Fischer. 1898. Pp. xii + 385.
- The Philippine Islands and their People.* DEAN C. WORCESTER. New York and London, The Macmillan Company. Pp. xix + 529. \$4.00.

# SCIENCE

EDITORIAL COMMITTEE: S. NEWCOMB, Mathematics; R. S. WOODWARD, Mechanics; E. C. PICKERING, Astronomy; T. C. MENDENHALL, Physics; R. H. THURSTON, Engineering; IRA REMSEN, Chemistry; J. LE CONTE, Geology; W. M. DAVIS, Physiography; O. C. MARSH, Paleontology; W. K. BROOKS, C. HART MERRIAM, Zoology; S. H. SCUDDER, Entomology; C. E. BESSEY, N. L. BRITTON, Botany; HENRY F. OSBOEN, General Biology; C. S. MINOT, Embryology, Histology; H. P. BOWDITCH, Physiology; J. S. BILLINGS, Hygiene; J. MCKEEN CATTELL, Psychology; DANIEL G. BRINTON, J. W. POWELL, Anthropology.

FRIDAY, NOVEMBER 11, 1898.

## CONTENTS:

<i>On Recent Progress toward the Solution of Problems in Hydrodynamics:</i> PROFESSOR ERNEST W. BROWN.....	641
<i>Botany at the Anniversary Meeting of the American Association for the Advancement of Science (I.):</i> DR. ERWIN F. SMITH.....	651
<i>Acta of the International Conference on Scientific Literature.....</i>	660
<i>Current Notes on Meteorology:—</i> <i>West Indian Service of the Weather Bureau; Antarctic Meteorology; The Ascent of Aconcagua:</i> R. DEC. WARD.....	665
<i>Current Notes on Anthropology:—</i> <i>Indian Geographic Names; The Mayan Hieroglyphics; Coincidences:</i> PROFESSOR D. G. BRINTON.....	666
<i>Scientific Notes and News.....</i>	667
<i>University and Educational News.....</i>	670
<i>Discussion and Correspondence:—</i> <i>Fish Ova for Educational Purposes:</i> DR. HUGH M. SMITH. <i>On a Suitable Name for the New Planet:</i> DR. S. C. CHANDLER. <i>The Minor Planet DQ:</i> W. J. HUSSEY. <i>The Stress-strain Relations of Rubber:</i> C. M. BRODMALL. <i>The Lower Saurian Cochineal:</i> PROFESSOR T. D. A. COCKERELL. <i>The Endowment of American Archaeology:</i> W. S. PROSSER. <i>The Sense of Solidity:</i> PROFESSOR JOHN DEWEY.....	671
<i>Scientific Literature:—</i> <i>Free Expansion of Gases:</i> M. Peabody <i>on the Thermodynamics of the Steam Engine:</i> R. H. THURSTON. <i>Taylor on Prismatical Formule and Earthwork:</i> M. M.....	675
<i>Scientific Journals.....</i>	678
<i>Societies and Academies:—</i> <i>Biological Society of Washington:</i> F. A. LUCAS. <i>Biological Section of the New York Academy of Sciences:</i> DR. GARY N. CALKINS. <i>Geological Conference of Harvard University:</i> J. M. BOUTWELL.....	678
<i>New Books.....</i>	680

MSS. intended for publication and books, etc., intended for review should be sent to the responsible editor, Professor J. McKeen Cattell, Garrison-on-Hudson, N. Y.

## ON RECENT PROGRESS TOWARD THE SOLUTION OF PROBLEMS IN HYDRODYNAMICS.

In this paper I shall not attempt to give an exhaustive account of the progress which has been made in hydrodynamics of recent years. Such an account, though possibly useful for purposes of reference, would be tedious and unsuitable for reading before an audience. I shall, therefore, try to give some idea of the general lines on which research has been carried on, laying stress on the more important discoveries and avoiding, as far as possible, mere technical details.

The choice of the period to be selected is not difficult. In 1846 Professor Stokes presented a report on the condition of hydrodynamics at that time, and this was continued by Professor Hicks in 1881–1882. Both these papers are printed in the reports of the British Association for the Advancement of Science. In the *Mathematische Annalen* for 1887 Mr. A. E. H. Love gave a summary of our knowledge of Vortex Motion, and Hicks practically carried this to the present day in his presidential address before Section A of the British Association in 1896. Professor Darwin's article on Tides in the *Encyclopædia Britannica* carries our knowledge of that subject to 1888. Hence I shall take the progress made in the general subject since 1882; the work on Tides will be taken from 1888



only, while Vortex Motion will be omitted altogether.

The application of mathematics to the solution of many natural problems in fluid motion possesses one difficulty which is not common to most of the problems which confront physicists. It arises from the fact that we are frequently unable to apply the method of approximation. It usually happens that when a problem arises from some natural phenomenon it is not capable of direct solution. But the mathematician is generally able to consider a simpler problem which more or less closely corresponds to the given conditions. Having solved it, he is able to take into account the conditions of the actual problem, and so to obtain a solution to any degree of accuracy which may be desired. This is frequently *not* the case with problems in fluid motion. The differential equations of motion may, perhaps, be written down, but the limitations which have to be imposed before a solution can be discovered are so numerous that the solution, when found, often gives no approximation at all to the real circumstances. To illustrate this, we need only mention the case of a sphere moving through water. If we neglect the friction between the water and the surface of the sphere, the viscosity and compressibility of the water, it is easy to find all the circumstances of the motion. But when the velocity of the sphere is not small, and we take these neglected circumstances into account, the motion, as any one will agree, quite changes its character. Instead of the stream lines—that is, the lines followed by the molecules of the fluid—being regular curves, eddies are formed along the surface of the sphere, and the motion in the rear of the sphere becomes turbulent and seems to defy all attempts at calculation. Further, the resistance to motion caused by the fluid, instead of being zero, as in the simplified problem, actually becomes very large. And here, it is to

be remembered, we are dealing with a simple case of a class of problems which has a high practical interest—the resistance experienced by a ship moving at a speed which we are accustomed to expect, say, from ten to twenty miles an hour. The engineer now knows fairly well the resistance by experiment. But neither he nor the mathematician can calculate the resistance when the speed is forty miles an hour, and this speed has already become an accomplished fact.

I shall first deal with problems in which the motion is irrotational, that is, where the separate molecules of the fluid are not supposed to possess any rotation of their own independently of the rotation of the whole mass. In a fluid which is non-viscous such a molecular rotation can never be set up by any conservative system of forces. If we neglect the viscosity, and the skin friction of the solid with which it is in contact, all motions considered will be of the irrotational class. This class can be again divided into two others: first, that known as *continuous*, in which the pressure never comes out to be negative; and secondly, that known as *discontinuous*, in which we may have a negative pressure or a surface across which there may be a finite change of velocity. In the first case the fluid completely occupies the spaces around the solid with which it is in contact. In the second case hollows may be formed and there may be a free surface, or the fluid in motion may be in contact with other fluid at rest. After treating these two classes of problems I shall go on to mention the advances made in various kinds of wave motion, including the tides. Then will follow the motions and forms of masses of fluid rotating about an axis under their own gravitation only. Finally, the influence of viscosity will be considered.

We shall first consider those problems in which the fluid is incompressible and with-

out viscosity and its motion is irrotational, steady and takes place in two dimensions. If we take the plane of motion to be that of  $(x, y)$  this class, of course, includes the case of motion in three dimensions where the motion of every particle in a straight line perpendicular to the plane of  $(x, y)$  is the same. The theory depends on the velocity-potential  $\varphi$  and the stream-function  $\psi$ . If  $u, v$  be the velocities of a particle of the fluid at the point  $(x, y)$  the following equations hold :

$$u = \frac{\partial \varphi}{\partial x} \quad , \quad v = \frac{\partial \varphi}{\partial y} \quad ,$$

$$u = - \frac{\partial \psi}{\partial y} \quad , \quad v = + \frac{\partial \psi}{\partial x} \quad ,$$

$$\frac{\partial^2 \varphi}{\partial x^2} + \frac{\partial^2 \varphi}{\partial y^2} = 0 = \frac{\partial^2 \psi}{\partial x^2} + \frac{\partial^2 \psi}{\partial y^2} .$$

Putting  $z = x + iy$  ,  $w = \varphi + i\psi$ , these equations show that the determination of the motion reduces to the discovery of a function

$$w = f(z) ,$$

which will satisfy the given boundary conditions.

When  $w$  has been determined as a function of  $z$ , the curves,

$$w = \text{pure imaginary} ,$$

give the stream-lines, that is, the lines followed by the molecules of the fluid in their motion. The velocities are determined by partial differentiation with respect to  $x, y$ .

It is unnecessary to say more about the general problem. It is that of Dirichlet in the Theory of Functions. Solutions can, in general, only be obtained by the inverse process of taking known solutions of

$$\frac{\partial^2 \varphi}{\partial x^2} + \frac{\partial^2 \varphi}{\partial y^2} = 0 \text{ or } \frac{\partial^2 \psi}{\partial x^2} + \frac{\partial^2 \psi}{\partial y^2} = 0 ,$$

and inquiring what boundary conditions they can be made to satisfy. When the motion is discontinuous the boundaries, in-

stead of being fixed walls, are free surfaces along which the velocity is constant.

As we are searching for the stream-lines

$$w = \text{pure imaginary} ,$$

that is, the lines parallel to the real axis in the  $w$ -plane, all that is necessary is to find the curves in the  $z$ -plane which correspond to lines parallel to the real axis in the  $w$ -plane. The problem is, therefore, reduced to one of conform representation. For walls consisting of straight lines a few cases have been long known, being solved by Schwarz's method. Some new ones, with more complicated rectilinear boundaries, were given by Réthy in 1895.

In 1890 Mitchell gave a new form to Schwarz's method which enabled him to solve some further problems in discontinuous motion. These are mainly the cases of jets issuing from apertures into fluid which may be at rest or in motion. This was shortly afterwards modified and extended by Love. Still later B. Hopkinson added the case where several sources or sinks might be present. (These are points where the fluid is supposed to enter or leave in finite quantities.) The transformation does not in general contain infinities, but Hopkinson includes the case where  $\frac{dw}{dz}$  becomes infinite like

$$\frac{A_1}{z - z_1} + \dots + \frac{A_n}{(z - z_n)^n} .$$

Several hydrodynamical examples are given, but the most interesting are the electrical applications.

These problems are of little practical value. They frequently demand the existence of dead water behind the moving solid. For example, if a rectangular board be drawn through a fluid it is directly seen that the fluid behind the obstacle is far from being at rest, which the theory would indicate. Again, if water is entering into

a large tank which is full, by means of a projecting tube in the side of the tank, the fluid, instead of spreading in all directions (by the theory), actually moves like a fluid cylinder for a short distance. In fact, the fluid, instead of moving back along the outside of the projecting tube, actually moves the other way. The difference is, of course, caused by the viscosity of the fluid, which, even when small, produces vortex or eddy motion of a complicated kind. The difficulties have been stated with some detail and with several illustrations by Lord Kelvin in *Nature*, 1894.

Just lately Professor Hele-Shaw has succeeded in photographing the movements of an actual fluid under similar circumstances. It is striking to observe that when the motion of the water takes place between two parallel plates not far apart, and when its velocity is not very great, the stream-lines follow almost exactly the theoretical positions which they would have under the assumptions made above. In the case of a rectangular plate held at an angle of  $45^\circ$  to a steady stream the stream-lines agree almost exactly with the hyperbolas given by theory. When the parallel plates are not close, however, or the motion takes place in a tube of not too small section, any variation in the diameter of the tube soon produces turbulent motion.

When the motion takes place in three dimensions I divide it again into continuous and discontinuous motion. On neither is there much to say. When the motion is continuous, and there are no forces acting on the solid which is moving through the fluid, the system of differential equations admits of three integrals, and the integration is practically finished if we can find a fourth. Several Continental writers have been considering, during the past two or three years, under what circumstances a fourth integral of specified form may exist. Miss Fawcett has examined the case of the

motion of a solid of the form known as an isotropic helicoid when gravity is the only force acting. The most interesting case is that where the solid starts from rest. The path followed by the center of gravity is traced. The motion of an anchor ring when there is circulation through the aperture has been discussed by Greenhill, Basset and Dyson. The first-named has applied the  $\sigma$ -functions to the solution of the problem. Basset has also discussed the motion of a spherical bowl. No problem of discontinuous motion in three dimensions has been yet solved, notwithstanding many unpublished attempts. I shall return to this subject later on.

Coming next to the general theory of wave-motion, including the problem of the tides, two main classes may be distinguished. Waves of expansion belong primarily to the theory of sound and they will not be touched upon here. The second class concerns the different kinds of waves which our every-day experience of water in motion brings before us. It includes wave-motion on the large scale as exhibited by the tides, and on a smaller scale in the long waves which are known under the name of a 'ground-swell' in the Atlantic; next the waves whose effects have the greatest destructive power—the short waves whose height is not very small compared with their length—the waves raised by the wind in a river, those which follow in the wake of a ship, the solitary wave travelling up a canal or in some rivers, known in England as a 'bore;' finally, the waves which are very small and which are mainly propagated by the surface tension of the fluid. These last are known as capillary waves and will only be mentioned incidentally. A general distinction of all these waves on the surface of water is made by mathematicians—the long waves, where it appears permissible to neglect the vertical acceleration of the particles of the fluid without materially affect-



ing the results, and the short waves, where this vertical acceleration may not be neglected in the equations of motion. I shall, as far as possible, deal with them in this order.

The neglect of the vertical acceleration, which implies that the dynamical pressure is equal to the statical pressure, greatly simplifies the problem of wave-motion. Neglecting compressibility and viscosity, the ordinary problems of long wave-motion are not very difficult. The motion of long waves in canals is an old problem and was used by Airy for explaining the tides. A paper by McCowan in 1892 on these long waves when the section of the canal is uniform must be mentioned. Usually the canal has been taken to be of rectangular section. McCowan treats one which has sloping sides. Incidentally he obtains a canal of such shape that these long free waves are propagated along it without change of form. But a more important result is the detection of a serious error in Airy's explanation of the double high-tide, sometimes observed in estuaries and rivers. The method adopted was, as usual, one of continued approximation, and Airy fell into the error—not unknown to mathematical physicists—that of carrying his approximations further than the initial assumptions warranted. It appeared that the wave might divide into two or even three waves. McCowan shows that this division of the wave is without foundation when the equations are correctly treated and that, therefore, Airy's explanation of the double high-tide fails. The double high-tide is still unexplained.

The general theory of tides is fully dealt with and brought up to date by Professor Darwin in his article in the *Encyclopædia Britannica* of date 1888. Two important papers have appeared since then. To report how these two papers have advanced our knowledge of tidal theory, a few re-

marks must be made on the general problem.

The theory of the tides is mainly one of forced oscillations. The sun and moon, moving in orbits round the earth whose essential nature is periodic, their motions are expressible by means of sums of sines or cosines of angles which vary with the time, and the periods of these terms differ. The difference of the attractions on the earth and the water which covers it produces oscillations with periods which correspond to those of the sun and moon. Hence the periods of the principal tides will be known in advance. Notwithstanding this fact, the general equations which express the motion of the water have hitherto only been integrated on the following assumptions: First, that the particles of water never move far from their mean position in comparison with the radius of the earth—an assumption which is easily justified and need not be discussed. Secondly, that the ocean covers the whole earth supposed spherical. Thirdly, that the depth of the ocean is uniform or a function of the latitude only. Fourthly, that the attraction of the ocean on itself is to be neglected. The last phrase simply means that we neglect the difference of the attraction of the water on itself in its actual form from its attraction in the nearly spherical form it would assume if there were no disturbance.

The irregular shapes of the bed and shores of the ocean make calculation of the effects due to them almost impossible. But the attraction of the ocean on itself should be susceptible to calculation. Hitherto this has always been neglected, owing to mathematical difficulties. Poincaré and Hough, in two papers which have lately been published quite independently and nearly at the same time, have taken it into account. Of these two papers Hough's is the most important in view of the applications.

Previous writers, and particularly Darwin, have used simple sums of harmonic terms. Hough uses Zonal Harmonics and finds that this enables him to include the attraction of the ocean on itself. In particular the fortnightly tide has to be altered from 5 to 8 per cent. owing to this cause. Poincaré makes a rough estimate only, which is double this amount. At the same time he points out that the irregular shape of the continents may alter the coefficients of certain terms to a large extent. In consequence of this he criticises the arguments of Thomson and Tait, who attempt to explain the difference between theory and observation by the solid tides which the moon and sun must produce in a solid earth possessing slight elasticity. He leaves the question open, however. Poincaré's paper contains much more in the way of theoretical researches, which must be omitted here. Hough also determines the free oscillations by means of an indefinite determinant.

When we do not neglect the vertical acceleration of the particles of fluid the mathematical treatment alters and becomes more difficult. It is in general supposed that the height of the wave is small in comparison with the distance between the crests. In 1883 Lord Rayleigh discussed the short waves which are seen in front of an object trailed along the water, and also the longer waves that are left behind. His method is to find the effect produced by a line of disturbance inclined at an angle to the direction of steady motion of the fluid. The effects observed by Froude in his famous experiments on ship-waves are fairly well accounted for. This year a paper by Mitchell has just appeared in which he calculates the wave-resistance due to a body shaped approximately like a ship. Again the results are not unsatisfactory. Lord Kelvin has solved a similar problem in several articles in the *Philosophical Magazine*

for 1886-7. He considers the effect of small inequalities in the bed of a stream. Of special interest are the standing waves produced by a stone, or by a hole in the stream-bed, or by a wavy bottom, such as we sometimes see left on the sea shore by the retreating tide.

When the wave-height, wave-length and the depth of the fluid are comparable in magnitude the problem becomes very difficult, as the waves are not in general propagated without change of shape. They were first treated by Stokes. In 1889 von Helmholtz took up the general problem and considered the effect of the wind in making permanent waves. Mitchell has traced the free-wave in the case of infinite depth and its changes as it proceeds. Incidentally he finds again the case where the crest becomes a cusp with an angle of  $120^\circ$ , a result predicted by Stokes from simple considerations. A paper by W. Wien should be mentioned; in it the forms of the waves at the surface of separation of the two media are discussed, and forms for the waves produced by the winds, more or less closely approximating to actual phenomena, are found. The wave-fronts are figured by means of Schwarz's method of representing conformably a lemniscate on a circle.

The solitary wave has received a fair share of attention. In this wave the height is not necessarily small compared with the depth of the fluid, and it may travel for a long distance along a uniform canal with little or no change of form. Experiments have been made and the results published by Scott Russell. Boussinesq and Lord Rayleigh have lately investigated his figures from the mathematical standpoint, and have given a simple formula for the relation between the wave-length and the height which agrees with that deduced by Scott Russell from experiment. Korteweg and de Vries, in 1895, extended the theory of the solitary wave and showed that a new type—named

enoidal—can be propagated. They also proved that a depression without a corresponding elevation can move along, but such depressions are generally unstable. McCowan and Stokes have also treated these waves. The existence of free oscillations in canals has been investigated by Greenhill, Lamb and MacDonald by Fourier's methods. There is some doubt about Lamb's results. MacDonald has shown that it is necessary to take into account the possibility of satisfying the surface conditions and that simple formulæ are not sufficient; this point will be readily appreciated. The criticism appears to be valid, but the subject needs elucidation.

An interesting problem is obtained by considering the tiny waves formed in a glass of water when the glass is made to vibrate by means of a violin bow drawn across its edge. Rayleigh has shown that they are due to capillary action. It is curious that the number of waves found on the water in a given time is double the number of vibrations made by the glass in the same time.

A good deal of interest has been taken during the last two decades in the forms assumed by masses of fluid rotating about a fixed axis under their own attraction only. Darwin and Poincaré are mainly responsible for the developments which the subject has received, although much has been done by Madame Kowalewsky, Basset, Dyson, Bryan and Love. To give an account of all this work would take me far outside the limits of this paper, and I shall, therefore, simply mention some of the more interesting results obtained by the first two writers.

In 1886 Darwin worked out fully the various possible forms of the Jacobian ellipsoids, showing where the limits of stability came. In 1887 he took up the more general problem of two nearly spherical masses of fluid rotating like rigid bodies

round a fixed axis under their own attractions only. This problem is of great importance in theories of cosmogony. Especial attention is paid to the cases where the two bodies get very near to one another. When quite close they may coalesce and form dumb-bell shaped figures. Or the smaller mass may have a tendency to break up into two parts, as shown by a furrowing in its contour.

Poincaré took the subject up from a different point of view. He starts with the rotating ellipsoidal form and investigates what forms of relative equilibrium are possible when small deviations from the ellipsoid occur consistently with the conditions. He figures a pear-shaped form of possible equilibrium, and also discusses, with much detail, the stability of the various figures.

I am indebted to Professor Darwin for a reference to a paper by Schwarzschild, which has just appeared in the *Annals of the Munich Observatory*. In this memoir certain portions of Poincaré's work, with respect to the exchange of stabilities between two classes of possible figures of equilibrium at the place where they meet, are criticised. He also examines the stability of Roche's Ellipsoids by means of Lamé's functions, and shows that there is no figure of bifurcation in this series.

A considerable amount of attention has been devoted to our last subject, the viscosity of fluids, partly owing to the mathematical interest of the subject and partly to the difficulty of obtaining any close approximation to the results afforded by natural phenomena. It must be stated at the outset that in all the work hitherto attempted the motion is supposed to be sufficiently slow to enable us to neglect the squares and higher powers of the velocities. Practically this entails a serious limitation on the usefulness of the results. Even the most casual observation shows that when



the velocity exceeds a limit which is very easily reached, eddies are formed and the motion entirely changes its character. Korteweg has made some suggestive remarks on this point in a paper on the stability of the motion of viscous fluids. He remarks that the existence and formation of eddies was generally supposed to be due to unstable solutions of the equations of motion. von Helmholtz, however, had found that when a solution with given boundary conditions in a simply-connected region is obtained, that solution is unique. Hence, we cannot attribute the formation of eddies to other solutions which in fact do not exist. Korteweg further proves that this unique solution is stable. Hence, neglecting squares and products of the velocities, it is evident that having got a unique stable solution, eddies cannot be formed. Concerning these eddies, he says: "When, on the contrary, squares and higher powers of the velocities are taken into account I have my reasons for supposing that even in the case of a sphere moving with uniform velocity—if such a state of steady motion can be reached—the motion must finally become unstable." Lord Rayleigh has also attempted to examine how viscosity affects the motion, and how eddies, when formed, are maintained.

"Lord Kelvin concludes that the linear flow of a fluid through a pipe or of a stream over a plane bed is stable for very small disturbances, but that for disturbances of more than a certain amplitude the motion becomes unstable, the limits of stability being smaller the smaller the viscosity." (Lamb's *Hydrodynamics*.) It is possible that a remark made by Klein in his lectures on the top may have some bearing in this case. He points out that near the limit of stability, obtained as usual by neglecting the second and higher powers of small quantities, instability really takes place when we include them. It is, indeed, possible that all viscous fluid motions as at

present investigated are really unstable and that eddies are always formed. It is instructive to read Reynolds' experiments of 1883 as to the point at which, with increasing velocity, stream lines appear to break up into eddies.

A warning must be given against laying too great a stress on the equations of motion. They are formed under certain suppositions as to the character of the internal friction of the fluid, but we have no security that these suppositions represent the facts. At the same time most of the different assumptions made lead to the same equations, so that only a very fundamental alteration would affect the equations of motion.

Another difficulty arises with the skin friction at the surface of a body moving in the fluid. The difficulty arises from the fact that the action along the wall in contact with the fluid is treated quite differently in the cases of no friction and very small friction. The mathematical character of the motion may be completely altered. The difference is this. With non-viscous fluids we assume a finite slip of the fluid along the wall. If even the smallest coefficient of friction be introduced, a finite slip cannot be consistently allowed. The whole subject is very obscure. It is now believed by some prominent physicists that no such finite slip actually takes place at all.

A somewhat easier problem is the decay of waves proceeding along water, owing to the influence of viscosity. In several short papers during the last three years in the *Comptes Rendus*, Boussinesq has treated the various kinds of waves, in many cases reducing his results to numbers. A practical application is a determination of the time necessary for the sea raised by a storm to subside. Hough has treated a similar problem, namely, the effects of viscosity on ocean currents and on tides of long period.

He concludes that for big slow currents—such as the Gulf Stream—the friction of the ocean bed is by far the most important factor in the dissipation of the energy of motion, while for the short waves in deep water viscosity becomes paramount. The continued existence of ocean currents is a problem not satisfactorily explained. They are usually attributed principally to the tendency of the winds to blow on the average mainly in one direction. Against this is urged the dissipation of the energy thus acquired, by the viscosity of the fluid. Hough concludes that too much effect has been attributed to viscosity. Such currents will doubtless take a long time to start, but when once set in motion the modulus of decay is so large that energy is dissipated very slowly and the winds are sufficient to supply the energy lost by viscosity. The long-period tides, again, are supposed to be greatly affected by viscosity. If, however, Hough's conclusion that the modulus of decay is comparable more nearly with 20 years than with a few months those tides whose periods are as great as one or even six months will be but little affected. Hence the differences between observation and the results of the equilibrium theory of the tides, originally attributed to viscosity, cannot be explained in this way.

A few special problems of motions of solids have been solved, the squares of the velocities being neglected. The motion of a sphere and the linear motion of an ellipsoid in an infinite fluid had been solved. Edwardes, in 1892, added the rotational motion of an ellipsoid and the motion of fluid through a channel bounded by a hyperboloid of revolution. As before stated, the results have little more than a mathematical interest.

To attempt to give any idea of the possible directions in which future progress is likely to be made is a dangerous task. One can, however, do something by mentioning

the problems in which a little progress has been made and also those which have been before the scientific world for some time and remain yet unsolved. For some of the indications given below I am indebted to friends who have themselves contributed to recent progress.

Problems in discontinuous motion in two dimensions in an infinite, frictionless, incompressible fluid are now without fundamental difficulties. In fact, they are mainly exercises in conform representation. The problem is reduced to that of finding a function to satisfy Laplace's equation for two dimensions with given boundary conditions. No special service will be gained by hydrodynamics, by solving for new forms of boundaries, unless the cases arise in experiment. But I have mentioned the fact that no problem of discontinuous motion in three dimensions has yet been solved. The difficulty is one which can easily be appreciated. The theory of functions deals with a complex of the form  $x + iy$ , and this suits all problems in two dimensions. But little has been done with a vector in three dimensions, and certainly nothing has been built up concerning it which corresponds to the results obtained for the two dimensional-vector. The subject of discontinuous motion was set for the Adams prize in 1895; this is the prize which has produced Maxwell's essay on Saturn's Rings and J. J. Thomson's on Vortex Motion. A solution for a solid of revolution was asked for, and it was generally supposed that the circular disc would be the easiest to attempt. No essay was sent in. One prominent mathematician, who has aided considerably in the development of hydrodynamics, mentioned that he had worked for six months and had obtained absolutely nothing. A magnificent reception, therefore, awaits the first solution!

Some mention has been already made of difficulties awaiting solution in tide and

wave problems. Whether much more can be done by the present analytical methods is not certain. We may frequently meet in this department with series which formally satisfy the equations, but which either converge very slowly or not at all. The theory of free and forced waves, depending to a large extent upon methods of approximation, when numerical results are required for comparison with observation, is in many respects fairly satisfactory if the height of the wave crest above the mean level is not very great and if the motion is slow. But there are comparatively few problems solved for shorter waves in confined bodies of water. The oscillations of water across a canal of circular section is an instance of a problem which should yield to analysis. But little is known of the causes which produce double and other curious kinds of tides in enclosed areas.

Another class of problem is the wave-resistance experienced by various shaped bodies moving over water, especially when the velocity is not small. That this class is becoming extremely important, in view of the high speeds attained by torpedo boats, there can be no doubt. The lines of a ship are at present a matter mainly of experience. One of the most puzzling things is the difference in the speed qualities of two ships built on the same plans. A very slight difference in the lines will frequently enormously alter the speed qualities, and one can scarcely doubt that this is due to the differences in the waves which are formed as the ship moves. The kind of problem thus presented to the mathematician is always a difficult one. Briefly stated, it is a problem where a slight difference in the boundary conditions makes a large difference in the effects produced. A similar difficulty occurs when one approaches the limits of stability of steady motion.

The treatment of viscosity and skin friction seems to be a subject lying nearer to

one's grasp. The difference between no viscosity and small viscosity—namely, the mathematical assumptions of finite slip—and no finite slip—has already been pointed out; this requires further investigation. Again, the fact that in all problems hitherto solved, only the first powers of the velocities are taken into consideration seems to point to an opening for research. We cannot hope that, even should this single difficulty be overcome to a certain extent, the mechanical difficulties would be made much easier. But every step taken ought to lead to some further insight into the most intractable subject that mathematical physics presents. It must be admitted that the practical engineer has almost no use for any of the results obtained by the theory as it at present stands. It may be answered that pure science does not look to practical ends. This is perfectly true in general. But it can hardly be an argument in the case of hydrodynamics, the very bases of which are assumptions which are supposed to approximate more or less closely to actual conditions.

In conclusion, I cannot resist making, or rather repeating, an appeal to our pure mathematicians to devote more attention to this subject. The literature is easily accessible. The English treatises of Lamb, Basset, Thomson and Tait will supply most of the needs of a student, while the works of Voight and Kirchhoff and the *Handbuch der Physik* of Winkelmann may be used to supplement them. Again, Stokes' report of 1846 and that of Hicks in 1881-2 will furnish the main points in the history of the subject. On Vortex Motion we have the later paper of Love in 1887 and the presidential address of Hicks to the British Association in 1896. On Tides, Darwin's article in the *Encyclopædia Britannica* brings our knowledge up to 1888. Most of the work done since 1882



is to be found in the columns of such easily accessible periodicals as the Philosophical Magazine, the Proceedings of the London Mathematical Society and the Proceedings and Transactions of the Royal Society. A full index of titles of papers up to date, with short abstracts, is obtainable from the Jahrbuch über die Fortschritte der Mathematik and the *Revue Semestrielle*.

It is, of course, unfair to ask anyone successfully engaged on his or her own special line of research to leave it for doubtful profit in another. But much may be done by those who have the direction of the studies of the future generation by interesting and suggestive courses of lectures. Pure mathematicians will not find their knowledge useless here, and students will not be backward in following the footsteps of such men as Laplace, Stokes, Kelvin, von Helmholtz and Rayleigh. The tendency towards the separation of pure mathematics from their applications to physical problems has already been arrested. The future progress of Hydrodynamics appears to demand a closer union of these two branches of science.

ERNEST W. BROWN.

Haverford College.

BOTANY AT THE ANNIVERSARY MEETING  
OF THE AMERICAN ASSOCIATION FOR  
THE ADVANCEMENT OF SCIENCE.

I.

SECTION G was organized Monday noon, August 22d; Dr. W. G. Farlow, President. Regular sessions were held Tuesday morning, afternoon and evening and Thursday morning and afternoon; Wednesday and Friday being given up to excursions. Fifty-six papers were listed and forty-seven were read.

Thursday morning Mr. A. B. Seymour, on behalf of the Committee on Bibliography, appointed at the Madison meeting, made a report of progress, which dealt principally

with the question of subject arrangement. On motion of the Secretary, the Section directed the Committee to include Bacteriology in the list of subjects covered by this Bibliography.

The large number of papers and the limited time prevented full discussion in many instances. Numerous excursions also interfered more or less with the regular work of the Section, but these afforded much pleasure to all who could take part in them and were not least of the Boston attractions.

Visiting botanists were very hospitably entertained, and altogether the Boston meeting was exceedingly pleasant and profitable.

The following abstracts have been prepared with much care, in most cases from the authors' MSS. or abstracts, and it is to be hoped that they are reasonably free from errors, and ample enough to give the many who could not be present a clear idea of what was said and done.

*The Carposporic Type of Reproduction of the Rhodophyceæ.* BRADLEY M. DAVIS.

RECENT investigations in this field of research show a tendency to depart from the teachings of Fr. Schmitz. These were characterized by the assumption of a second act of fertilization in the Rhodophyceæ exhibited in the phenomenon of fusion between auxilliary cells and filaments or processes put out by the carpogonium. The speaker described studies of his own upon *Champia*, showing their divergence from the doctrines of Schmitz, and followed with a more general discussion of the peculiar conditions found here, expressing himself as in sympathy, in the main, with the recently published views of Oltmann. All evidence at present points to the probability that the cell-fusion phenomenon following the development of the carpogonium is associated with and the result of nutritive functions. The entire group of Rhodophyceæ is so pe-

cular that any attempt to establish a general type of reproduction is fraught with great danger.

*The Comparative Morphology of the Pistils of the Ranunculaceæ, Alismaceæ and Rosaceæ.*  
ERNST A. BESSEY.

THE uni-ovulate pistil in the Ranunculaceæ originates as an open leaf in whose axil grows a mass of cells from the receptacle forming one side of the cavity of the pistil whose other sides are formed by the laminae and by the curved distal portion of the carpel. Into this cavity grows a median ovule from the axillary mass of receptacular cells. *Sagittaria* and *Alisma* have practically the same structure, except that the ovule in the latter grows directly from the receptacle instead of from an outgrowth of it. *Potentilla* and *Fragaria* show a course of development very similar to the foregoing; an open pistil is formed, but the ovule, instead of growing from the receptacle, grows from the thickened edge of one or the other of the laminae. This similarity of development apparently supports that system of classification of the Angiosperms, in which there are three diverging lines of development having a common origin, one with the Alismaceæ first, being the Monocotyledonæ, the two others forming the Dicotyledonæ, one with the Ranunculaceæ lowest being the Thalamifloræ and passing up to the Heteromereæ and to the Bicarpellatæ, the other with the Rosaceæ lowest being the Calycifloræ and passing up to the Inferæ.

*Origin and Homologies of Blepharoplasts.*

HERBERT J. WEBBER.

THE new features emphasized by the author in this paper were as follows: The blepharoplasts in *Zamia* arise *de novo* in the cytoplasm of the generative cell, as previously described by him in the case of *Ginkgo*. They appear first as minute bodies with a few kinoplasmic filaments centered

upon them. At this time no differentiation into outer membrane and interior contents can be distinguished. As they increase in size the radiating filaments become more abundant and an outer membrane becomes plainly differentiated.

In the bursting of the blepharoplast to form the spiral cilia-bearing band of the spermatozoid the first change, other than increase in size, is distinguishable in an early prophase of the division of the generative cell. The vacuolated contents of the blepharoplast begin gradually to contract away from the outer membrane, which meanwhile increases in size. When the division has reached the metaphase the contents have become contracted to a very small body, and the outer membrane, which has become considerably extended, is shown in section to be broken into numerous segments or plates. The disappearance of the central nucleolus-like contents seems to be correlated in some way with the growth of the outer membrane. Appearances suggest that it is utilized as food matter in the growth of the membrane. In the next stage which the writer has studied, an early telephase, the blepharoplast is represented by numerous round or oblong granules grouped in a somewhat irregular spherical mass, which stain the same as the outer membrane of the blepharoplast in the preceding stage. It would seem that the outer membrane of the blepharoplast breaks up into numerous segments which assume a roundish form and become crowded together into a spherical mass through the action of the cytoplasm.

In a late telephase a slender membrane can be discovered protruding from this mass of granules and bending toward the nucleus. As the development advances, the membrane grows in length and width, and the granules meanwhile gradually arrange themselves along one side and decrease in number. During the further development

of the membrane the granules gradually disappear and apparently either unite directly to form the membrane or are absorbed through its growth. Some preparations give evidence that the granules fuse together to form the membrane, and the writer is inclined to this interpretation of the phenomena presented.

The further stages in the elongation of the membrane into the cilia-bearing band of the antherozoid have been described by the writer in another place.

*The Blepharoplast in the Spermatogenesis of Marsilia.* DR. W. R. SHAW.

IN the development of the male prothallia of *Marsilia vestita* no blepharoplasts or other centrosome-like bodies are found in any of the six cell divisions or resting stages preceding the formation of the primordial spermatogenous cell, 'central cell,' of each of the two antheridia; nor are any such bodies found in that cell or during its division. The first appearance of centrosome-like bodies is in the spindle poles during the telephase of the second division of the spermatogenous tissue. After this division is complete, *i. e.*, in the 'grandmother cells' of the spermatids, each of these bodies grows into a pair of *blepharoplastoids* which increase in size. They remain together and move into the other region of the cytoplasm, and disappear during the following cell division. During the anaphase or telephase of this division there are formed, at the poles of the spindle, new bodies. After the division, *i. e.*, in the 'mother cells' of the spermatids, each of these bodies develops into a pair of *blepharoplasts*. The blepharoplasts separate, at the same time increasing in size, and move to opposite poles of the cell, where they remain throughout the last division leading to the formation of the spermatids. The further development closely resembles that of the blepharoplasts in the spermatozooids of the cycads.

*Observations on the Relative Moisture Content of Fruit Trees in Winter and in Summer.*

PROFESSOR C. S. CRANDALL.

FROM samples of trunks and branches of apple trees taken January 15th and 16th and August 3d, and thoroughly air-dried, with careful weighing before and after, the author concludes that, as grown under Colorado conditions at least, there is hardly an appreciable difference between the summer and winter moisture.

In the discussion which followed, Professor D. T. MacDougal stated that the water content in the trees in August was practically the winter content, the separative layer in the leaves having probably already begun to form, and that for the determination of the *summer moisture* samples should have been taken sixty to seventy days earlier.

*Some Observations bearing upon the Symbiotic Mycoplasma Theory of Grain Rust.* PROFESSOR H. L. BOLLEY.

MANY facts and arguments go to show that Erickson's hypothesis has not been established, and is not necessary to account for the first appearances of grain rust. The author finds that uredo and acidiospores (*Aec. berberidis*, *U. rubigo-vera* and *U. graminis*) germinate readily when placed under favorable conditions; that, when other conditions are the same, shaded, spindling plants are as much subject to infection as those grown in the sunshine, and, finally, that when oats and wheat were grown in rust-proof cages there were no infections whatever, although close outside and for miles around every plant bore numerous pustules.

*Some Unique Examples of Dispersion of Seeds and Fruits.* PROFESSOR W. J. BEAL.

A POPULAR account, illustrated by specimens. To be printed in full in *The American Naturalist*.

*Starch Distribution as affected by fungi.* DR.

BYRON D. HALSTED.



THE leaves to be studied are placed in 50 per cent. alcohol to remove the chlorophyll, and are then passed into a weak solution of iodine. In a few hours, if the leaf is thin, the starch responds to the iodine test and is located by the blue color it assumes. Tested in this way the parts of plants which are attacked by fungi, *e. g.*, leaf spots due to *Peronospora*, *Cystopus*, *Synchytrium* and *Puccinia*, and galls due to *Cystopus*, *Gymnosporangium*, *Plasmodiophora* and *Rhizobium* show a marked accumulation of starch. The starch is either in the discolored spot or immediately around it. This distribution is very striking in the leaves of *Podophyllum* attacked by *Puccinia podophylli*, starch being abundant in the well-defined areas, while none was met with beyond the small veins that served as boundaries to the infested portions. The galls of peach roots, the cause of which is still unknown, are gorged with starch. Turnips affected by club root carry a large amount of starch, while the healthy tissue is comparatively free from it. In like manner, the root tubercles of the *Leguminosæ* contain much starch, while the roots which bear them are comparatively free from it.

*The Effect of an Atmosphere of Ether upon Seeds and Spores.* DR. C. O. TOWNSEND.

IN order to determine the effect of ether upon the germination of seeds and spores a series of air-tight damp-chambers holding one litre were prepared. After soaking the seeds for twenty-four hours in pure water they were transferred to the damp-chambers which contained respectively 1,  $2\frac{1}{2}$ , 5 and 10 cc. of ether dissolved in 100 cc. of water. One chamber was left free from ether for comparison. It was found that 1 cc. of ether hastened the process of germination slightly, but the subsequent growth of the seedlings was somewhat retarded by the action of the ether. In the chambers containing  $2\frac{1}{2}$  and 5 cc. of

ether the process of germination was retarded. The amount of retardation varied from a few hours to several days, depending upon the strength of the ether atmosphere and upon the kind of seed used. An atmosphere containing 10 cc. of ether prevented the seeds from germinating. If the seeds were removed from this strong atmosphere of ether at the end of from seven to ten days, and placed under favorable conditions, they germinated as readily as if they had not been placed in the ether atmosphere. On the other hand, if the seeds remained in the strong atmosphere of ether two weeks they seemed to lose their vitality.

The influence of an ether atmosphere upon spores was investigated by placing the spores upon plates of gelatine containing 10 cc. of sugar. These plates were then placed in damp-chambers containing  $\frac{1}{10}$ ,  $2\frac{1}{2}$ , 5 and 10 cc. of ether, one chamber remaining free from ether for control, the spores in the atmosphere containing  $\frac{1}{10}$  cc. of ether germinated a little earlier than did those in the ether-free atmosphere, while those in the stronger atmospheres of ether were retarded in germinating. Not only did the spores continue to live in the atmosphere containing 10 cc. of ether, but they were able to germinate in about ten days without removing from the ether atmosphere. The amount of retardation was found to depend upon the strength of the ether atmosphere and upon the kind of spores.

*The Toxic Action of a certain Group of Substances.* DR. RODNEY H. TRUE.

ZOOLOGISTS and botanists have long regarded certain salts, of which sodium chloride and potassium nitrate are commonly used representatives, as being essentially lacking in toxic action and operative only through their osmotic activity. In this study cane sugar was assumed to be a purely osmotic agent, and the concentration

in which the majority of a number of filaments of *Spirogyra* survived, after an exposure of twenty-four hours, was regarded as the measure of the osmotic action which the alga can endure. This boundary concentration was found to lie at 0.75 gram molecules per litre. Assuming the action of the other substances studied, viz.: glycerine, potassium nitrate and sodium chloride, to be likewise purely osmotic, the boundary concentrations were calculated to lie as follows: glycerine, 0.75 gram molecules per litre; potassium nitrate, 0.45 gram molecules; and sodium chloride, 0.47 gram molecules. The actual boundary concentrations found by the method used for sugar were as follows: glycerine,  $\frac{1}{2}$  gram molecules per litre; potassium nitrate,  $\frac{1}{10}$  gram molecules; and sodium chloride,  $\frac{1}{10}$  gram molecules. The concentrations producing plasmolysis were as follows; glycerine,  $\frac{1}{3}$  gram molecules per litre; potassium nitrate,  $\frac{1}{4}$  gram molecules; sodium chloride,  $\frac{1}{4}$  gram molecules; and sugar,  $\frac{1}{3}$  gram molecules. The boundary concentration for glycerine lies at a concentration greater than that of the cell sap, and probably causes death by osmotic action. The boundary concentrations of potassium nitrate and sodium chloride lie much below the point having the same osmotic value as the cell sap, and much below the boundary concentration calculated on the assumption of purely osmotic action. Consequently, potassium nitrate and sodium chloride exert a pronounced toxic influence upon *Spirogyra*.

*Types of Vegetation on the Florida Keys.* C. L. POLLARD.

PAPER, partly ecological, partly floristic. Six distinct belts or zones of plant life are recognized. The main part of the paper consisted of an enumeration and discussion of the characteristic species of these belts, as observed during a six weeks' visit in the spring of 1898.

*Potato as a Culture Medium with some Notes on a Synthesized Substitute.* DR. ERWIN F. SMITH.

THE length of this report makes it seem best to relegate the abstracts of my own papers, which are long and rather technical, to the forthcoming volume of the Proceedings of the Association, where they may be found by those who desire to consult them.

*Some Little Used Culture Media, which have proved valuable for Differentiation of Species.* DR. ERWIN F. SMITH.

*The Temperature and Transpiration of Desert Plants.* PROFESSOR D. T. MACDOUGAL.

THE author reported data taken from field notes made in the desert of the Little Colorado River in 1898.

The temperatures of the bodies of succulent plants in this region at midday is often as high as 45° C., the critical point of protoplasm, and 6° to 8° higher than the surrounding air. The enormous transpiring force exerted is met by the high-soil temperature, which in volcanic sand reaches 40° to 42° C. around the absorbing roots. The actual amount of water used by desert plants, when furnished with an unlimited supply, is very small, however. By use of a potometer it was found to be not more than one-tenth as much as from a corresponding mesophyte of temperate latitudes. Desert plants are, therefore, incapable of great transpiratory or absorptive activity.

*The Leaf-spot Disease of the Apple, Phyllosticta pirina, and Several Unrelated Forms occurring therewith.* PROFESSOR WM. B. ALWOOD.

PAPER records common occurrence and life cycle of *Phyll. pirina* Sacc. and the occurrence therewith of three apparently unrelated forms, viz.: *Sphaeropsis malorum*, *Hendersonia mali*, and an undetermined species.

*Notes on Some Diseases of Southern Pines.*

HERMANN VON SCHRENK.

OF the numerous fungous parasites of the southern pines *Trametes pini* is one of the most destructive. It attacks older trees, entering through a knot and causing decay of the heartwood up and down the trunk. The mycelium dissolves portions of the wood fibers, at first changing them to cellulose. After a time the solution stops, and the wood then appears full of holes with a white lining, the holes separated by lamellæ of apparently sound wood. The 'local' action of the mycelium is characteristic of numerous fungi destroying wood. The wood not destroyed seems to be protected against the attacks of the fungus ferment by some substance which infiltrates into the wood cells. In the wood attacked by the mycelium of *Trametes pini*, a compound allied to the humus compounds was found, giving the wood a brown color. It is possible that this may be one of a class of preventive substances.

Another prevalent disease is due to *Trametes radiciperda*, which enter the trees through the roots. The mycelium passes up the trunk, causing decay similar to that of *Trametes pini*. It was found destroying numerous trees of *Pinus palustris* and *P. echinata*.

*A remarkable Increase in Size of Leaves of Kalmia angustifolia apparently due to Reduction of Light.* PROFESSOR W. J. BEAL.

ON May 14, 1898, before flowering, some plants with a little soil attached were removed from an open place at Grayling, Michigan, where they are common, and transferred to the State Agricultural College, 130 miles south, where they were planted in muck, kept wet, and screened about 8 feet from the ground with laths and the leaves of trees, which cut off at least one-half of the light during the middle of the day and a larger per cent. morning and

evening. On July 28th the three branches here exhibited were cut from the plants and pressed till dry. The largest leaf on each branch (measured when dry) is  $37 \times 17$ ,  $45 \times 16$  and  $47 \times 15$  millimeters, while the largest evergreen leaf (growth of the previous year) is  $22 \times 9$ ,  $25 \times 6$  and  $25 \times 6$  millimeters, *i. e.*, a leaf of this year easily has a surface four times that of a leaf of last year. Similar results were obtained with *Kalmia glauca*. No control plants were retained.

*Half Shade and Vegetation.* DR. BYRON D. HALSTED.

EXPERIMENTS were made in shading various truck crops with frames of lath placed upon supporting stakes. The space between the lath equalled the width of the lath, so that one-half of the direct rays were intercepted. The temperature under the frames (monthly averages of daily observations) was lower than in the full sun, as follows: May,  $4^{\circ}$ ; June,  $4.2^{\circ}$ ; July,  $6.5^{\circ}$ ; August,  $7.7^{\circ}$ ; September,  $16.6^{\circ}$ . In general the shade retarded germination, noticeably of the first crop of lima beans, but the opposite was true for the second, or mid-summer planting. All root crops, such as turnips, carrots, potatoes, had a larger leaf surface in the shade, but the roots were smaller. Shade improved the salad crops, lettuce, spinach and Swiss chard. The crop most improved of all by shade was celery. With seed, or fruit-producing crops, such as beans, peas, egg-plants, tomatoes, cucumbers, the time of blooming was retarded and the period of fruitfulness materially prolonged. The foliage is of a deeper green in the shade than in the open. In carrots there is a strong tendency to broaden the dissected portions; in short, in the various crop plants there is an attempt to increase the size of the blade of the leaf. The behavior of the plants was also dissimilar. For example, the exposed bean plants in



the brightest and warmest days made all sorts of shifts to reduce the exposure, changing the position of the leaflets from morning until evening, while in the shade the leaflets hung out horizontally and were not noticeably heliotropic. The leaves in the shade were usually much thinner than those grown in full exposure. The record of this fact was made by sunprints of the leaves themselves, the shaded ones invariably being less opaque than the ones grown in the sun. Numerous sunprints were shown to establish the fact of the lesser density of the shade-grown leaves. A study of wild plants along the same lines was made in a wood lot and adjoining clearing. The cinnamon fern (*Osmunda*) was noted in particular to have graceful, drooping leaves in the wooded land, while in the open the fronds were nearly upright. The leaflets of this fern grown in the shade were .098 millimeters in thickness, while in the cleared land the thickness was .258 millimeters. Many other differences as to hairiness, color of stems, etc., were noted.

*Influence of Wet Weather upon Parasitic Fungi.*

DR. BYRON D. HALSTED.

THIS paper records a striking parallelism between excessive rainfall and the abundance of fungi. May of the present year was remarkably wet, and the following June brought an abundance of parasitic fungi, rust of hollyhock, cedar and mandrake; smut of spring lily, wheat and oats; and many other. The peach-leaf curl fungus was common everywhere. The year 1889 was noted for its wet summer and also for the destruction of potatoes by the rot. The year, since then, nearest like 1889 was 1897, when again July was phenomenal for heavy precipitation, it being 10.19 inches in 1889 and 11.42 in 1897. Last season was like that of 1889 in the outbreak of the *Phytophthora* in the potato fields, causing the wholesale rotting of the tubers. The *Phytoph-*

*thora phaseoli* Thaxter was discovered in 1889 and reappeared destructively last season. The records of the New Jersey Experiment Station show that in both of the years mentioned there was much black rot (*Phylospora Bidwellii* Ell.) of the grapes and rust (*Gymnosporangium macropus* Lk.) in the apple orchards. In 1894 the growing season opened with a wet May and closed with a rainy September. There were long periods of cloudy weather, and often it was hot and showery. It was this year that witnessed the unprecedented outbreak of the fire blight of apple, quince and pear.

In 1896 there was a rainy June and July, and during this period the asparagus rust (*Puccinia asparagi* DC.) made its appearance in the eastern United States to an alarming extent, and last year it was in even greater abundance. There are not sufficient data for safe and substantial generalizations, but heavy rainfalls in spring seem to induce rusts in grains and orchard and garden crops, and the fire blights of fruit trees. Mid-summer precipitations favor the decay of fruits, particularly the stone fruits, and the rotting of potatoes. Rainfall does not express all the meteorological conditions that need to be taken into consideration in this connection.

In the discussion Dr. Smith noted that peach-leaf curl, *Tuphrina deformans*, was reported to the United States Department of Agriculture in the spring of 1898 from a great many places throughout the country, causing more complaint than at any time during the previous 12 years.

*The Botanic Gardens of Buitenzorg, Java.*

DAVID G. FAIRCHILD.

THIS was a popular lecture, illustrated by about forty lantern slides. The speaker announced that one of the main objects of the lecture was to interest Americans in the establishment of a stipendium of \$1,000 by means of which an American botanist

or zoologist could visit the gardens every year and spend from six to eight months in study there. Slides were exhibited showing the remarkable extent of the gardens, their adaptability to the cultivation of any tropical plant, their especially rich collection of palms, Pandanus and ficus trees, their many new and well equipped laboratories, the herbarium and library. Photographs of the native gardeners and collectors, which form such an important part of the gardens, were also exhibited. The attempt was made to give an idea of the wealth of biological, both botanical and zoological, material which was to be found there, and stress was laid upon the importance of laboratory facilities in the tropics. The beauties and charms of Dr. Treub's mountain garden at Tjibodas were illustrated, and botanists and zoologists were exhorted to make the effort to see this unparalleled hermitage of tropical biology. The remarkable growth of the gardens in recent years, and the attention and stipendia which Dr. Treub has attracted to it, made it seem probable in the speaker's mind that Buitenzorg will be soon the International Biological Institute of the Tropics, as Naples is the International Marine Biological Institute.

*Notes on the Strand Flora of Florida.* HERBERT J. WEBBER.

THIS was a popular lecture illustrated by fifty lantern slides. The east coast of Florida as far south as Biscayne Key (latitude about  $26^{\circ} 75'$ ) is lined with low sand dunes ranging from ten to thirty feet in height. The coast line is being gradually extended by the deposition of sand, which is probably carried southward from the Cape Hatteras region. In almost every peninsula and island along the coast of this portion of the State numerous ridges or series of ridges several hundred feet apart, evidently lines of old dunes, run

parallel with the coast and mark various stages in its recession. The deposition of sand carried by the waves forms shoals or banks 200 to 400 feet from the shore. This gradual piling-up under the action of currents and waves evidently goes on until the bank becomes sufficiently high to protrude from the water at low tide, and then the wind and waves throw it up still higher. Where these banks remain above water for several months certain dune-building plants, such as *Sesuvium portulacastrum*, *Iva imbricata*, *Cakile maritima*, *Panicum amarum*, etc., spring up, and as they grow the wind banks the sand around them, thus forming a low line of dunes, to which the sand washed up by the waves is being continually added.

The formation of new lines of dunes in front of the old ones, now lining the shore, plainly shows the gradual recession of the coast line. The dunes now lining the coast at Daytona consist of two parallel ridges of equal height, close together (50 to 100 feet apart), and in some places of a third line in various stages of formation. After the dunes reach the usual height vegetation covers their surface, and thereafter the wind has little effect on them, except gradually to increase their width and height.

*Uniola paniculata* is the main sand-binding grass to be found on the top and seaward side of the first line of dunes. Here it forms almost 75 per cent. of the vegetation, and this zone may, therefore, be properly termed the *Uniola* formation. Species of *Spartina*, *Panicum*, *Ipomea*, *Yucca*, *Serenoa*, *Croton*, *Euphorbia*, *Opuntia*, etc., are also commonly found mingled with *Uniola*, but only to a small extent. At the base of the main line of dunes a number of plants grow naturally and serve as dune builders. The principal ones of these are *Panicum amarum*, *Ipomea pes-caprae*, *Butatys littoralis*, *Iva imbricata*, *Cakile maritima*, etc. These are also found to a greater or less extent on

the tops of the main dunes and in salt marshes, but play their most important rôle in dune building. Growing in bunches, as they do, they catch and hold the sand which is continually drifting about at the base of the dune, and in the course of time banks of increasing height are formed about them until a second line of dunes, nearer the water, is formed.

The islands and keys along the mainland from Biscayne Bay to Key West are of coral formation. Here the vegetation, which is mostly tropical, differs totally from that of the sand dunes above described; the 'mangrove formation,' so well described by Schimper and Karsten, being the most common. Probably the most interesting strand plant of the open beaches in this section is *Agave decipiens*, which is widely distributed along the strand of tropical Florida, being disseminated almost wholly by bulblets produced in place of the flowers. These bulblets are not injured by extended soaking in salt water. They are usually carried here and there by the tide, are thrown up on the beach by the waves, take root, and produce new plants.

The islands along the west coast of Florida are largely of mangrove formation. Shoals are formed by the action of the water, and on these the mangrove finally takes root, and the roots catch and retain sea weeds and other floating matter, thus gradually building up a humus earth around the trees. On the seaward side these trees interrupt the waves, and thus in time a bank of shell is thrown up, and where the forces continue for long periods more or less extended islands are formed. In their simplest form these consist of a low ridge along the seaward shore, composed mainly of fragments of shell thrown up by the waves, and a mangrove swamp on the landward side. In time the interior of the forming island becomes too high for mangrove vegetation, and the latter gradually

gives place to the typical hammock vegetation, that is, live oak, palmetto, etc., which in Florida usually covers all soils rich in humus. The typical islands along this section of the coast, therefore, are composed of a central tract of hammock bordered on the seaward side by a belt of sterile shell land from 100 to 600 feet wide and on the landward side by a mangrove swamp.

The most characteristic plants of the mangrove formation are *Rhizophora mangle*, *Avicennia nitida*, *Laguncularia racemosa*, etc. The most characteristic of the shell belt on the seaward side are probably *Forestiera porulosa*, *Myrsine rapanea*, *Coccoloba wifera*, *Juniperus virginiana*, etc. Here, as on the east coast, *Iva imbricata*, *Cakile maritima*, *Ipomœa pes-capræ*, etc., grow abundantly on the margin of the water.

*Notes on the relative infrequency of Fungi upon the Trans-Missouri Plains and the adjacent foothills of the Rocky Mountains.* PROFESSOR C. E. BESSEY. (Read by title.)

*Fungus gardening as practiced by the Termites in West Africa and Java.* DAVID G. FAIRCHILD and O. F. COOK.

IN the absence of Mr. O. F. Cook the matter relating to Javaese Termites alone was given. Mr. Fairchild called attention to the presence of three species of Termites as yet unidentified which are fungus growers. The nests of these insects are composed of two parts: (1) the earthen-walled galleries, consisting of tunnels in every direction through the earth or even above it, made by cementing together mouthfuls of mud which the workers of these colony-producing insects deposit like brick layers on a wall; and (2) the wooden maché combs which form the gardens of the Termites, which are built up of wood particles that have passed through the bodies of the workers. These combs are miniature labyrinths, the walls of the passages being covered, top, bottom and sides,



with a microscopic sward of fungal hyphæ, which give to it the appearance of a neatly-cut lawn. Rising scattered over this lawn are innumerable cabbage-shaped bodies from microscopic beginnings up to sizes as large as that of a pin head. These bright, almost pearly lustrous bodies, which give to the galleries a most fairy-like appearance, are the compound conidiophores of a species of fungus, presumably a hymenomycete, although cultures of the spores of the mature hymenomycete found growing from the combs failed to establish a connection between the mature form and the cabbages, or more properly termed *cauliflowers*, since they, like the cauliflower, contain organs of propagation.

Photographs showing the nests of three distinct species of Termite possessing three distinct forms of cauliflowers were shown, and attention was called to the fact that these three species of Termite, although building their nests side by side, often in contact with each other, begin immediately a deadly warfare with each other whenever the workers or soldiers, which latter possess large shear-like mandibles, of one nest trespass upon the domains of a neighbor. Unlike the wars of the real ants, in which, as Lubbock has shown, each nest is a unit and its inhabitants war with the inhabitants of any other nest of the same species, the wars of the Termites are race or species affairs. Termites of one species collected in Buitenzorg, Java, and taken to Tjibodas, some 15 or more miles distant, showed the friendliest relations with individuals of the same species collected there, while individuals of different species, though coming from nests actually almost touching each other in the same hill, fought in the arena of an inverted watch glass, invariably, until one or the other was killed, and often mutilated in a most shocking manner. The fights of these Termites offer unrivalled opportunities for a study of the psychology of these

lower animals. The fact that these Termites do actually live upon the 'cauliflowers' of the fungi found growing in their nests was proved by repeated examinations of their stomachs, in which the remains of characteristic conidiophores and half-digested conidia were discovered. The extreme sensitiveness of the insects to light prevented direct observations being made as to their method of eating the cauliflowers.

The three forms of conidiophores were remarkably distinct mycologically, and yet the general effect of the cauliflowers made up of these conidiophores grouped together in masses was much the same. Drawings illustrative of these differences were shown.

ERWIN F. SMITH,

WASHINGTON, D. C.

Secretary.

(To be concluded.)

ACTA OF THE INTERNATIONAL CONFERENCE ON SCIENTIFIC LITERATURE.\*

OPENING MEETING, TUESDAY, OCTOBER 11

1. PROFESSOR DARBOUX moved that Sir John E. Gorst be the President of the Conference. The vote having been unanimously accepted—

2. Sir John Gorst took the chair and welcomed the delegates. It was then resolved:

3. That Professor Armstrong be the Secretary for the English language.

That Professor Korteweg be the Secretary for the German language.

That M. La Fontaine be the Secretary for the French language.

4. That the Secretaries, with the help of shorthand reporters, be responsible for the *procès verbal* of the proceedings of the Conference in their respective languages.

5. Professor Foster read out the names of delegates appointed to attend the Con-

\* From *Nature*; a copy has not as yet been received by SCIENCE.

ference, and gave an account of the correspondence relating to the non-representation of certain countries.

The following resolutions were then agreed to:

6. That the ordinary hours of meeting be 11 a. m., to 1 p. m., and 2:30 to 4:30 p. m.

7. That each delegate shall have a vote in deciding all questions brought before the Conference.

8. That English, French and German be the official languages of the Conference, but that it shall be open for any delegate to address the Conference in any other language, provided that he supplies for the *procès verbal* of the Conference a written translation of his remarks into one or other of the official languages.

9. Professor Foster having formally presented the Report of the Committee of the Royal Society, copies of which were forwarded, in April last, to the several governments represented at the Conference, the discussion of the recommendations was opened, and it was resolved:

10. That the Conference confirms the principle that the Catalogue be published in the double form of cards and book.

11. That Schedules of Classification shall be authorized for the several branches of science which it is decided to include in the Catalogue.

12. That geography be defined as limited to mathematical and physical geography, and that political and general geography be excluded.

13. That anatomy be entered on the list as a separate subject.

14. That a separate schedule be provided for each of the following branches of science: Mathematics, Astronomy, Meteorology, Physics, Crystallography, Chemistry, Mineralogy, Geology (including Petrology), Geography—Mathematical and Physical, Paleontology, Anatomy, Zoology, Botany,

Physiology (including Pharmacology and Experimental Pathology), Bacteriology, Psychology and Anthropology.

15. That each of the sciences for which a separate schedule is provided shall be indicated by a symbol.

16. Professor Foster announced the reception of a letter from the German Chargé d'Affairs to the President of the Royal Society, stating that Geheimer Regierungsrath Professor Dr. Klein, of Göttingen, had been appointed German Delegate to the Conference.

The regulations to be observed in the preparation of cards or slips were then taken into consideration, and it was resolved:

17. That Italian should be added to the list of languages not requiring translation.

18. That for each communication to be indexed at least one slip, to be called a *Primary Slip*, shall be prepared, on which shall be either printed or type-written or legibly handwritten in Roman script:

(i.) *Title-entries*.—The author's name and the full title of the communication, in the original language alone if the language be either English, French, German, Italian or Latin.

In the case of other languages the title shall be translated into English or such other of the above five languages as may be determined by the Collecting Bureau concerned; but in such case the original title shall be added, either in the original script or transliterated into Roman script.

The title shall be followed by every necessary reference, including the year of publication, and such other symbols as may be determined. In the case of a separately published book the place and year of publication and the number of pages, etc., shall be given.

(ii.) *Subject-entries*, indicating, as briefly as possible, the principal subjects to which the communication refers. Every effort

shall be made to restrict the number of these subject-entries.

Such subject-entries shall be given only in the original language of the communication if this be one of the five previously referred to, but in other cases in English or in such other language as has been used in translating the title.

[The Belgian delegates stated that they abstained from voting on the part of this resolution relating to subject-entries.]

SECOND MEETING, WEDNESDAY, OCTOBER 12.

19. Professor Korteweg having expressed the desire to be relieved of his office, it was resolved that Professor Weiss be appointed Secretary for the German language.

The following resolutions were adopted :

20. That the registration symbols used in the Catalogue be based on a convenient combined system of letters, numbers or other symbols, adapted in the case of each branch of science to its individual needs, and in accordance, as far as possible, with a general system of registration.

21. That the authoritative decision as to the Schedules be entrusted to an International Committee, to be hereafter nominated by this Conference.

22. That the Conference is of opinion that the delegates should be requested to take steps in their respective countries to organize local committees charged with the study of all questions relating to the International Catalogue of Scientific Literature, and to report within six months to the International Committee.

23. That the International Committee (Resolution 22) be instructed to frame a report, not later than July 31, 1899, which shall be issued by the Royal Society and incorporated in the decisions of the Conference.

24. That in all countries in which or wherever a Regional Bureau is established, as contemplated in the 16th resolution of

the International Conference of 1896, the Regional Bureau shall be responsible for the preparation (in accordance with Reg. 7 of the Royal Society's Report) of the slips requisite for indexing all the scientific literature of the region, whatever be the language in which that literature may appear.

That each Regional Bureau shall transmit such slips to the Central Bureau as rapidly and as frequently as may be found convenient.

That in the case of countries in which no Regional Bureau is established, the Central Bureau, failing other arrangements, shall, upon special mandate, endeavor to undertake the work of a Regional Bureau.

[The Belgian delegates stated that they abstained from voting on this resolution.]

25. That the following recommendations of the Royal Society relating to the preparation of the Book Catalogue be referred to the International Committee for their favorable consideration, viz :

At determined regular intervals, not necessarily the same for all sciences, the Central Bureau shall compile from the slips and issue in a book form both an authors' and a subject-index of the literature published within that period.

This Book Catalogue shall be obtainable in parts corresponding to the several sciences for which slips are provided, and in such divisions of parts as may be hereafter determined.

In compiling the authors' index, in each of the sciences, the authors' names shall be arranged in alphabetical order, and each name shall be followed by the title of the paper and the necessary reference, and any other such symbols as may be determined.

The Book Subject Catalogue shall be compiled from the slips, as follows :

(i.) The subject-entries shall be grouped in sections corresponding to the registration letters on the slips, *i. e.*, to the several sciences.



(ii.) In each science the several subject-entries shall be arranged under headings corresponding to the registration numbers on the slips, the which headings and numbers shall be those contained in the authorized schedules of classification.

(iii.) The divisions indicated by registration numbers may be further subdivided by means of significant words or symbols.

(iv.) The nature of the subject entry may vary. Thus, as suggested in the cases of Mathematics and Physiology, it may be the title only; whilst in other sciences a special entry, more or less different from the title, may be provided on each slip. In all cases the number of subject-entries to be copied from a slip shall be determined by the number of registration numbers on the slip.

(v.) The mode of arranging subject-entries under a registration number, or under the subdivisions of a number afforded by significant words or symbols, may vary. They may either be arranged in the order of authors' names placed alphabetically, in which case the authors' names shall precede the subject-entry in the Book Catalogue, or they may be arranged either in an arbitrary order or in some order suited to the particular series of entries.

When in preparing an issue of the Book Catalogue it is found that a registration number has no entries collected under it the number and corresponding heading may be omitted from that issue.

To each part of the Book Catalogue corresponding to an authorized schedule there shall be appended an alphabetical index of the headings, and, if expedient, also of the significant words appearing in that part, showing on which page of the part each may be found.

After the publication of the first issue of the Book Catalogue the Director of the Central Bureau shall consult the Committees of Referees as to the desirability of

making changes in the classification, and shall report thereon to the International Council, who shall have power to authorize such changes to be made as they may think expedient.

26. That the following recommendations of the Royal Society providing for International Conventions in connection with the Catalogue be adopted:

Each region in which a Regional Bureau is established, charged with the duty of preparing and transmitting slips to the Central Bureau for the compilation of the Catalogue, shall be called a 'constituent region.'

In 1905, in 1910, and every tenth year afterwards, an International Convention shall be held in London (in July) to reconsider, and, if necessary, revise the regulations for carrying out the work of the Catalogue authorized by the International Convention of 1898.

Such an International Convention shall consist of delegates appointed by the respective governments to represent the constituent regions, but no region shall be represented by more than three delegates.

The rules of procedure of each International Convention shall be the same as those of the International Convention of 1898.

The decisions of an International Convention shall remain in force until the next Convention meets.

27. That the following recommendations of the Royal Society relating to the constitution of an International Council, which shall be the governing body of the Catalogue, be adopted:

Each Regional Bureau shall appoint one person to serve as a member of a body to be called *The International Council*.

The International Council shall, within the regulations laid down by the International Convention, be the Governing Body of the Catalogue.

The International Council shall appoint its own Chairman and Secretary.

It shall meet in London once in three years at least, and at such other times as the Chairman, with the concurrence of five other members, may specially appoint.

It, shall, subject to the regulations laid down by the Convention, be the supreme authority for the consideration of and decision concerning all matters belonging to the Central Bureau.

It shall make a report of its doings, and submit a balance sheet, copies of which shall be distributed to the several Regional Bureaux, and published in some recognized periodical or periodicals, in each of the constituent regions.

28. That the following recommendations of the Royal Society relating to International Committees of Referees be referred for consideration to the International Council when constituted :

The International Council shall appoint for each science included in the Catalogue five persons skilled in that science, to form an International Committee of Referees, provided always that the Committee shall be as far as possible representative of the constituent regions. The members shall be appointed in such a way that one retires every year. Occasional vacancies shall be filled up by the Committee itself, subject to the approval of the Chairman of the International Council, and a member thus appointed shall hold office as long as the member whose place he fills would have held office.

It shall be the duty of the Director of the Central Bureau to consult the appropriate Committee or Committees, by correspondence or otherwise, on all questions of classification not provided for by the Catalogue Regulations; or, in cases of doubt, as to the meaning of those Regulations.

In any action touching classification the Director shall be guided by the written de-

cision of a majority of the appropriate Committee or by a minute if the Committee meets.

Provided always that when any addition to or change of the schedule of classification in any one branch may seem likely to affect the schedule of classification of some other branch or branches, the Committees concerned shall have been consulted; and provided also that in all cases of want of agreement within or between the Committees, or of other difficulty, the matter shall have been referred for decision to the International Council.

All business transacted by the Committees shall be reported by the Director to the International Council at their next ensuing meeting.

#### THIRD MEETING, THURSDAY, OCTOBER 13.

The following resolutions were adopted :

29. That the Committee contemplated in Resolution 21 be constituted as follows : Professor Armstrong, Professor Descamps, Professor M. Foster, Dr. S. P. Langley, Professor Poincaré, Professor Rücker, Professor Waldeyer and Professor Weiss.

That this Committee be at liberty, if any of those named are unable to serve, to appoint substitutes, and also to co-opt two new members.

30. That the International Committee be termed the 'Provisional International Committee.'

31. That the Provisional International Committee shall be governed by the decisions of the Conference, but shall have the power of introducing such modifications in detail as may appear necessary.

32. Dr. Adler, referring to Resolution 20, said that he desired to place on record his view that the concluding words—"and in accordance, as far as possible, with a general system of registration"—the addition which he had agreed to as an amendment of his original Resolution, must not be re-

garded as modifying the first part of the Clause, or in any way throwing open the whole question of notation and classification.

33. Professor Rücker having made a statement as to the probable cost of the undertaking, and the delegates having stated what assistance in their opinion might be expected from their respective countries, it was resolved :

That the delegates to this Conference be requested to obtain information, and to report at any early date to the ' Provisional International Committee,' as to what assistance, by subscription or otherwise, towards the support of the Central Bureau may be expected from their respective countries.

34. M. Mascart called attention to Resolution 22 as being, in his opinion, incorrect in English, the intention being that the local Committee therein referred to should report to the International Committee.

35. The Royal Society was requested to undertake the editing, publication and distribution of a verbatim report of the Proceedings of the Conference.

36. It was resolved that the *procès verbal* of the Conference be signed by the Presidents and Secretaries.

37. On the motion of Professor Armstrong, the thanks of the Conference were accorded to the Society of Antiquaries for the use of their rooms.

38. On the motion of Professor Klein, a vote of thanks to Sir John Gorst for presiding over the Conference, and his conduct in the chair, was passed by acclamation.

39. On the motion of M. Darboux, a vote of thanks was passed to the Royal Society for their work in preparation for the Conference and their cordial reception of the delegates.

(Signed) JOHN E. GORST, *President*.

HENRY E. ARMSTRONG,

H. LA FONTAINE,

E. WEISS, *Secretaries*.

#### CURRENT NOTES ON METEOROLOGY.

##### WEST INDIAN SERVICE OF THE WEATHER BUREAU.

THE *Monthly Weather Review* for July contains a paper by Professor E. B. Garriott on the West Indian Service of the United States Weather Bureau. The Service was undertaken under an Act of Congress approved July 7, 1898. Observations by regular observers of the Weather Bureau were begun at Kingston, Jamaica; Santo Domingo; St. Thomas; Port of Spain, Trinidad, and Willemstad, Curaçoa, on August 9th. Observations at Santiago were begun on August 11th, and at Bridgetown, Barbadoes, on August 31st. Regular reports have for some years been received from Havana, Cuba; Nassau, Bahamas, and Hamilton, Bermuda. The central station is at Kingston, and all other stations of the system cable daily, to Washington and to Kingston, reports of observations taken at 6 a. m. and 6 p. m., 75th meridian time. When the weather conditions are unusual, or there are signs of an approaching hurricane, special observations are telegraphed. Additional daily morning and evening reports are telegraphed to Washington via Galveston, Texas, from Tampico, Vera Cruz and Coatzacoalcos, and from Merida, Yucatan. Arrangements have been made for the prompt distribution of hurricane warnings from Washington to West Indian and Southern coast ports in the threatened district. The Service is at present an emergency service, but it is expected that, with the cooperation of the European governments having possessions in the West Indies, and of the countries bordering on the Gulf of Mexico and the Caribbean Sea, a permanent system of stations can be established, which shall permit the forecasting of hurricanes and northers, and shall carry out a study of the climatologic conditions of the West Indies.



## ANTARCTIC METEOROLOGY.

THE recent revival of interest in Antarctic exploration is a welcome sign to meteorologists, for Antarctic meteorology is in a sad state of incoherence and uncertainty. Our knowledge of the meteorological conditions of the Arctic is now in a fairly satisfactory state as compared with what we know of the sister zone around the South Pole. The October number of the *Scottish Geographical Magazine* is a 'Special Antarctic Number.' It contains reprints of Sir John Murray's address before the Royal Society, on 'The Scientific Advantages of an Antarctic Expedition,' with the remarks of Buchan, Neumayer and others made in connection with that address. Further, 'A History of Antarctic Discovery,' by the acting editor, and a most valuable Antarctic Bibliography, containing titles of publications bearing dates from 1761 to 1898, compiled by Bartholomew. A chart of the South Polar Region, after Sir John Murray's scheme for Antarctic exploration, presents, in small marginal charts, the mean temperature and the isobars and winds of the region in February. On the latter chart a considerable number of wind arrows (in red) are added to the observed wind directions (in black), in order to emphasize the hypothetical wind circulation around the South Pole. This hypothetical circulation is strongly anticyclonic in character. It remains to be seen, as the result of observation, how accurate this prediction is.

## THE ASCENT OF ACONCAGUA.

THE physiological effects of the diminished pressure at high altitudes, noted during the ascent of Aconcagua in 1896, are vividly described by Fitzgerald in *McClure's Magazine* for October. During the night spent at 16,000 feet one of the porters suffered terribly from nausea and faintness. At 18,700 feet Fitzgerald himself was completely used

up. "It was very difficult to sleep more than a quarter of an hour or twenty minutes at a time without being awakened by a fit of choking." At 21,000 feet one of the porters was very ill, his face turning a greenish, livid hue. All the members of the party suffered from severe headache and mental depression, the usual symptoms of *soroche*. At 22,000 feet Fitzgerald was completely disabled, and was obliged to lie on his back, gasping for breath. He was so weak that he could not hold himself for more than a few paces at a time, and continually fell forward, cutting himself on the stones that covered the mountain side. The summit was reached by Zurbriggen, the Swiss guide, Fitzgerald himself being unable to continue the ascent owing to mountain sickness.

R. DEC. WARD.

HARVARD UNIVERSITY.

## CURRENT NOTES ON ANTHROPOLOGY.

## INDIAN GEOGRAPHIC NAMES.

SCATTERED over the map of the United States are many thousand local names derived from the various aboriginal dialects which were once spoken in the vicinities. In sound they are often harmonious and in meaning picturesque. It is a commendable curiosity which searches for this meaning, and also it is of ethnologic value, for sometimes these names are the chief or only evidence that the area where they occur was inhabited by some particular tribe or stock. A complete gazetteer of such would be most desirable, but the completion of such a task is a long way off.

One of the most diligent and capable students in the Algonquian geographic nomenclature is Mr. William Wallace Tooker. His latest publication on the subject is in the January number of the Publications of the Rhode Island Historical Society (Vol. V., No. 4). Its title is 'Indian Geographic Names, and why we should study them;

illustrated by some Rhode Island examples.' Its contents are well worth perusal and reflection.

#### THE MAYAN HIEROGLYPHICS.

In the *Deutsche Literaturzeitung*, August, 1898, Dr. Ed. Seler gives what is intended to be a withering review of the 'Primer of Mayan Hieroglyphics,' written by me and published in 1895. It could hardly be expected that Dr. Seler should be pleasantly impressed on reading the book, for I felt constrained in various passages (pp. 83, 87, 89, 91, 92, 99, 112, 114, etc.) to point out the patent errors into which he had fallen, and how often he had adopted the Abbé Brasseur's views, always without acknowledgment of his French authority. He makes himself especially merry over what I explain (p. 24) as the 'cosmic sign,' representing the world as a whole in the pictography of the Mayas. Had he been really acquainted with the symbolism of native American art, as shown, for instance, by Professor Putnam and Dr. Willoughby in their model paper on the subject (*Proc. Am. Assoc. Adv. Science*, 1896), or as appreciated in the writings of such students as Mr. Cushing, Dr. Matthews and Miss Fletcher, he would probably have been less humorous, certainly less dogmatic and possibly more just.

#### COINCIDENCES.

UNDER this title Professor Max Müller has an article in the *Fortnightly Review* which he closes in these words: "I shall remain true to my conviction that all coincidences, whether in mythology, religion, art or literature, have a reason, if only we can find it."

It is evident from the examples in the article that the Professor means an objective reason, one from external suggestion, and that coincidences to him signify appropriations.

Of course, in a certain percentage of cases this is so, and nobody would deny it; but

in another and large percentage it is not so. The coincidences are due to independent mental evolution along the same lines, under the impulse of the same desires. This is true in all four of the fields named by the essayist, as well as others; and it is perhaps the most significant discovery in modern ethnology. That Professor Max Müller has refused to accept it is the reason why his vast labors on Comparative Religion have exerted such incommensurate influence on anthropologic science.

D. G. BRINTON.

UNIVERSITY OF PENNSYLVANIA.

#### SCIENTIFIC NOTES AND NEWS.

A MONUMENT to Pasteur was unveiled, if the arrangements were carried out, at Lille, on November 5th, an oration in memory of Pasteur being made by M. Duclaux.

THE University of Vienna will place in the hall of the University a bust of Dr. Müller, whose life was sacrificed in attending the laboratory servant Barisch, infected with the plague in Professor Nothnagel's laboratory.

THE Royal University of Ireland has conferred its honorary D.Sc. on Mr. Thomas Preston, the physicist.

DR. T. H. BEAN has recently spent a month in making collections of fishes along the southern shore of Long Island, in the interest of the U. S. Fish Commission.

A VACANCY in the position of Marine Meteorologist, Mare Island Navy Yard, California, will be filled by a civil service examination on December 6th.

WE record with much regret the death of Dr. James I. Peck, assistant professor of biology in Williams College and Assistant Director of the Marine Biological Laboratory at Woods Holl. We hope to give in a subsequent issue some account of Dr. Peck's life and work. His untimely death is a serious loss to zoology and will be deplored by many friends.

THE death is announced of Dr. David A. Wells, the eminent writer on economics. It is, perhaps, not well known that he began his

career as a scientific author, to which, perhaps, may be attributed, in part at least, the valuable character of his work in economics. After graduating from Williams College, Wells entered the Lawrence Scientific School at Harvard as a special pupil of Louis Agassiz, and was subsequently lecturer on physics and chemistry at Groton Academy, Mass. At Cambridge, in 1849, he began, with George Bliss, the publication of *The Annual of Scientific Discovery*, which was continued until 1886. In 1856 he invented valuable improvements in the method of manufacturing textile fabrics. He also compiled several scientific text-books, including 'Science of Common Things,' 'Elements of Natural Philosophy,' 'Principles and Applications of Chemistry' and 'First Principles of Geology.'

WE are compelled also to record the death of Professor George Vestal, professor of agriculture and horticulture at the New Mexico Agricultural College, on October 24th, aged 41 years; of Dr. W. Koehs, docent for physiology at Bonn, and of M. J. V. Barbier, a well-known French geographer.

DR. H. F. MOORE, of the United States Fish Commission, has been making a careful examination of the physical conditions of Great Salt Lake, with a view to determine its adaptability to oysters and other salt-water and brackish-water animals. While it is known that the salinity of the open lake is so great as to preclude the possibility of the acclimatization of useful marine animals, it has been suggested that there are certain bays or arms of the lake, in which rivers discharge, where the density is lowered to a point somewhat less than that of ocean water, and where it may be possible for clams, oysters, crabs, terrapins and such animals to survive and multiply. Dr. Moore has not completed his inquiries, but it may be said that the outlook for an augmentation of the aquatic food resources of this region is not very promising, the amount of fresh water entering the lake being subject to great variation, and the existence of a natural food supply for the introduced species being uncertain. For a number of years people living near the lake have from time to time importuned the Fish Commission to make experimental plants of

fish and other animals in the lake and its tributary streams. Considerable numbers of young shad have been deposited in the rivers, but there is no evidence of their survival. The present inquiries will, it is thought, definitely settle the question.

MR. AXEL DANIELSON, of Stockholm, writes to the *Scientific American* in regard to the status of the Nobel bequest. He says that the case has been decided, or rather a compromise has been effected between the contesting parties. The relatives of the deceased will receive 3,800,000 Swedish crowns, a little more than \$1,000,000, so that there still remains for the prizes the sum of 25,000,000 crowns, equivalent to \$6,950,000. The income, computed at the rate of three per cent., will make the five prizes worth 150,000 crowns, or \$41,600 each. It is expected that the compound interest during the time, which will necessarily be long, that will elapse before the prizes can be awarded will increase the capital so as to cover the cost of managing the funds and the work entailed in properly distributing the prizes. It will be remembered that these prizes are to be awarded annually to persons making the most important discoveries in physics, chemistry, physiology or medicine. There is also to be a prize for the best literary contribution upon the subject of physiology or medicine, and also one for any person who has achieved the most or done the best things looking toward the promotion of the cause of peace throughout the world.

THE New York *Evening Post* learns from the *Berlingske Tidende* that the first competition offered by the Nansen fund, which was established soon after the return of the *Fram* in 1896, has just been advertised. The subject is a thorough work in embryology based on original investigation, and the amount of the prize is 1,500 kroner (about \$400). The result will be announced at the annual meeting of the Christiania Academy of Science, May 3, 1900.

THE German Colonial Council has requested the government to provide, as soon as possible, stations for agricultural experiments in German Southwest Africa and to establish a service for meteorological observations extending over the entire territory.



M. HENRI LECONTE made an address before the Paris Society of Commercial Geography on October 20th, on the colonial botanical gardens of France, in which he called attention to their inadequate support by the State. The total amount spent on these gardens is said to be only half as much as that given to the Dutch garden at Buitenzorg, and the results are small in proportion. M. Guy, representing the Minister of the Colonies, stated after the address that a commission would shortly be formed to study the administration of the experimental botanical gardens in the colonies.

THE Imperial Russian Geographical Society has decided to establish a Seismological Station at Irkutsk.

A CABLEGRAM to the London *Times* states that Sir John Forrest, Premier of Western Australia, has received a report from Sir Frederick McCoy, professor of natural science in the University of Melbourne, stating that his examination of fossils from the seams of the Collie coalfield, in Western Australia, shows that the deposit is of exactly the same geological age as the Newcastle coalfield, in New South Wales. He adds that the specimens of coal examined are equal to the best Newcastle coal. Professor McCoy congratulates the Premier on the discovery of this magnificent addition to the natural wealth of the colony.

CARNEGIE Library, at Homestead, Pa., was dedicated on November 6th by the founder, Mr. Andrew Carnegie, who spent \$300,000 in its erection.

THE National Educational Association will meet next year at Los Angeles, if favorable railway rates can be secured.

THE New England Association of Chemistry Teachers meets at the United States Hotel, Boston, to-morrow evening. Dr. H. M. Goodwin is the guest of the Association and will give 'An Address on Some Aspects of Physical Chemistry.' The President of the Association, Dr. Lyman C. Newell, will make a preliminary report on the progress of the movement instituted by the Association to promote efficiency in the teaching of chemistry.

THE fifth International Congress of Hydrology, Climatology and Geology met at Liege

from the 25th of September to the 3d of October.

THE Royal Geographical Society, London, will open its session on November 14th, when the meeting will be devoted mainly to a national Antarctic expedition. The President, Sir Clements Markham, will introduce the subject, and will be followed by other distinguished scientific men. The Society has just issued an appeal for funds for a national expedition. At the second meeting, on November 28th, Mr. C. W. Andrews will give an account of the interesting results of his year's investigations on lonely Christmas Island. Other papers that are expected are 'Explorations on the Caroline Islands,' by Mr. F. W. Christian; 'Explorations among the Canadian Rockies,' by Dr. Norman Colley, F.R.S.; 'Explorations in Sokotra,' by Dr. H. O. Forbes; 'Lake Rukwa and Central Africa,' by Mr. L. A. Wallace; and papers by Dr. J. W. Gregory and Professor W. M. Davis, of Harvard University.

ON October 25th an international monument in honor of Dr. Hans Wilhelm Meyer, the discoverer of adenoid growths, was unveiled in Copenhagen. The *British Medical Journal* states that the memorial, which is a bronze bust of more than life-size resting upon a granite base, stands in the Gefion Square, in East Copenhagen. It is the work of the Danish artists, Bissen and Runeberg. The Mayor of Copenhagen, several high officers of state and a number of professors of the medical faculty, of medical men and of the general public were present at the ceremony. The memorial was formally handed over to the municipality of Copenhagen by Sir Felix Semon, who delivered an address in which he pointed out the importance of Meyer's discovery, which had already saved thousands of people from life-long deafness and the lasting results of obstructed nasal respiration, and in future times would be similarly beneficial to hundreds of thousands and even to millions. He described Wilhelm Meyer as one of the greatest benefactors to mankind that the profession of medicine had ever known. After the monument was unveiled, M. Ollgaard accepted it on behalf of the City of Copenhagen.

REUTER'S agency reports that the German archaeologist Professor Belck was attacked, wounded and robbed by Kurdish marauders in the Sipan Dagh while separated from his escort. As the result of representations immediately made by the German embassy, the Sultan gave orders for the most rigorous pursuit and the punishment of the guilty parties. The perpetrators of the outrage have now been discovered and arrested. The property and a part of the money stolen have been recovered. In accordance with directions personally given by the Sultan, Herr Belck will receive every attention at the cost of the State. He is now at Van, still under medical treatment, but out of danger.

THE Swedish scientific expedition to the Klou-dike, under the conduct of Dr. Otto Nordensk-jöld, is now on its way home, and is expected to arrive in London about the end of the month. The expedition has been exploring since March last, and the results are expected to be of considerable interest.

AN expedition is about to leave England to investigate and make collections of the fauna of the island of Sokotra, situated eastward from Cape Guardafui. The party, consisting of Mr. W. R. Ogilvie Grant, of the Department of Zoology of the Natural History Museum; Dr. H. O. Forbes, the Director, and Mr. Cutmore, Taxidermist of the Liverpool Museums, will be conveyed from Aden by a steamship furnished by the British government. The Royal Society, the Royal Geographical Society and the British Association have made appropriations towards the expenses of the expedition.

It is still an open question whether the fauna of the sea is confined to belts near the surface and the bottom, or whether the intermediate zones are inhabited. To investigate this problem a deep-sea expedition has been organized, as we learn from the *London Times*, through grants by the Royal Geographical Society, the Draper's Company and the Fishmonger's Company, and has been placed under the direction of Mr. George Murray, Keeper of the Botanical Department of the Natural History Museum. The trustees of the British Museum have helped by granting Mr. Murray the necessary leave of absence and lending him the services of two of

the Museum naturalists, Mr. V. H. Blackman and Dr. Gregory. Mr. J. E. S. Moore, Dr. Sambon and Mr. Highly, of whom the last is an artist, complete the staff of the expedition. The steamship *Oceana* has been chartered and is being fitted with its deep-sea gear by the kindness of the Silvertown Telegraph Cable Company. The steamer was expected to be ready by November 5th, when it would proceed directly to the west coast of Ireland. Work will begin at the edge of the 100-fathom platform, about thirty miles west of Dingle Bay. The vessel will steam slowly for 10° westward. Continuous observations will be made with a vertical chain of tow nets, the length of which will be gradually increased until, when the depth of 2,000 fathoms is reached, the series will include thirty-eight tow-nets. Soundings and observations of temperatures will be made, and, if time permit, some deep-sea trawling. Experiments with various forms of self-closing nets, including the Tanner net employed by Professor Agassiz, will be made for the sake of comparison; but the main effort of the expedition is to determine the vertical distribution of oceanic life by a series of open nets.

WE learn from the *Philadelphia Medical Journal* that the State Legislature of Vermont has passed an Act providing for the equipment and maintenance of a State laboratory which shall include in its work 'the chemical and bacteriological examination of water-supplies, milk and all food-products, and the examination of cases, and suspected cases, of diphtheria, typhoid fever, tuberculosis, malaria and other infectious and contagious diseases.' The sum of \$5,000 has been appropriated for the establishment of the laboratory, and \$8,000 per year voted for running expenses. Dr. J. H. Linsley is director of the laboratory. It appears that only three States have established similar laboratories—Michigan, Massachusetts and New York.

---

#### UNIVERSITY AND EDUCATIONAL NEWS.

THE University of Cincinnati has again been presented with a gift of \$60,000, this time by Mr. Asa van Wormer, a retired merchant of

Cincinnati. This sum is to be devoted to the erection of a fire-proof library building. As the University is the custodian of the library of the American Association for the Advancement of Science, this gift will have an added interest.

THE sum of \$40,000 has been secured toward the erection of the new physiological laboratories of the University of Pennsylvania, but the plans and estimates for the buildings have not yet been decided upon.

THE Board of Estimate and Apportionment of New York City has allowed over \$13,000,000 for education, an increase of more than one million dollars over the expenditures of the present year. The increase is chiefly for new teachers and for increasing the salaries of those teachers who are now paid the least. It is satisfactory to note that the expenditure for education is the largest item in the budget of Greater New York and that the increase is twice as great as in any other direction. It is expected that in January bonds will be issued to defray the cost of the erection of new school buildings.

ON the 28th of October the north wing of the recently erected 'Mechanic Arts Hall' was opened with appropriate ceremonies by the University of Nebraska. Professor Morgan Brooks, who succeeds Professor Robert B. Owens as the head of the department of electrical engineering, gave his inaugural address, 'Electricity and Enlightenment.' Regent Morrill, of the Building Committee, reported the completion of the building, a substantial brick structure of modern construction, four stories in height and containing thirty rooms. Chancellor MacLean, in a brief address, dedicated it to the uses of the Industrial College, whose Dean, Dr. Charles E. Bessey, pledged the Commonwealth of Nebraska that the building should be used 'to promote that education of the people contemplated by the Act of Congress which founded the College.' Governor Holcomb unveiled a commemorative tablet, and in the course of his remarks expressed the hope that in the not-distant future there might be enough buildings on the campus to accommodate 5,000 students. A formal address in the evening by President Chaplin, of Washington

University, with brief congratulatory addresses and letters, closed the exercises.

AN international commission of architects has recently examined at Antwerp the plans submitted for reconstructing the buildings of the University of California in competition for the prizes offered by Mrs. Phoebe Hearst. One hundred and eight plans were submitted and of these eleven were selected for prizes, each of which was \$1,200. The final plan will be selected by a jury after visiting the site of the University.

THE summer school at Cornell University has been reorganized, being made a more integral part of the University and being arranged with special reference to the needs of high school teachers. Instruction will next summer be given by leading members of the faculty, including Professors De Garmo, Titchener, Atkinson, Bailey, Comstock, Roberts, Caldwell, Tarr and Fish.

THE faculty of the University of Chicago seems to contain an unusually large number of former college presidents and prospective college presidents. The presidency of Oberlin College has just been offered to Professor J. H. Barrows and the presidency of the University of Cincinnati to Professor Edmund James.

#### DISCUSSION AND CORRESPONDENCE.

##### FISH OVA FOR EDUCATIONAL PURPOSES.

THROUGH the medium of SCIENCE I desire to announce that during the fall, winter and spring months the United States Fish Commission will, on request, gratuitously supply educational institutions with living fertilized eggs of the various marine and fresh-water fishes cultivated at the government hatcheries in different parts of the country. The eggs of about twenty species can be regularly furnished from as many stations, several kinds of eggs being handled at most of the hatcheries.

The eggs can be sent in lots of 500 or 1,000, and will usually arrive at their destination in good condition. Most of the eggs available during the colder months are those of salmonoid fishes which are susceptible of shipment over long distances, when placed in layers on trays with wet cloth-bottoms, packed in sphagnum and crated. Salmon and trout eggs so packed



have been safely sent from this country to Europe, Asia and Australia. Eggs of marine species are shipped in tightly-closed jars containing water, and may be expected to arrive with not more than 50 per cent. loss at points that may be reached in twenty-four to thirty hours. Shad and pike-perch eggs do not stand distant shipment well unless accompanied by an attendant, but may be sent unattended short distances (covered in ten hours or less) either on trays or in cans containing water. Trout and salmon eggs are not likely to survive long shipments except immediately after fertilization and after becoming 'eyed.'

Some of the places at which hatcheries of the Commission are located, the kind of eggs available at each station, and the approximate period when they can be supplied, are as follows :

Woods Hole, Mass.—Cod, Nov. 15 to Jan. 30 ; flat-fish, Feb. and March ; lobsters, April to June.  
Gloucester, Mass.—Cod, Dec. 1 to Feb. ; pollock, Nov. and Dec.

East Orland, Me.—Atlantic salmon, Oct. to Feb.  
Green Lake, Me.—Brook trout, Nov. to Feb. ; land-locked salmon, Nov. to Feb. ; golden trout, Nov. and Dec. ; lake trout, Nov. to Feb.

St. Johnsbury, Vt.—Brook trout, Oct. to Jan.  
Washington, D. C. ; Havre de Grace, Md., and Gloucester, N. J.—Shad, April 15 to June 1.

Wytheville, Va.—Rainbow trout, Dec. to Feb.  
Erwin, Tenn.—Brook trout, Nov. and Dec.

Put-in Bay, Ohio.—Whitefish, Dec. 1 to Feb. 1 ; lake herring, Dec. and Jan. ; pike perch, April.

Northville, Mich.—Lake trout, Oct. to Jan. ; brook trout, Nov. to Jan. ; Scotch lake trout, Nov. to Jan.

Duluth, Minn.—Lake trout, Oct. to Feb.  
Manchester, Iowa.—Brook trout, Nov. to Jan. ; lake trout, Nov. to Jan.

Neosho, Mo.—Rainbow trout, Dec. and Jan.  
Bozeman, Mont.—Grayling, June ; black-spotted trout, June.

Leadville, Colo.—Brook trout, Oct. to Jan. 30 ; black-spotted trout, June ; rainbow trout, June ; Scotch lake trout, Oct. and Nov.

Baird, Cal.—Quinnat salmon, Aug., Sept., Dec. and Jan.

Clackamas, Oregon.—Quinnat salmon, Nov. 1 to Feb. 1.

When eggs other than those regularly handled by the Commission are desired, an attempt will be made to obtain them.

Persons intending to take advantage of this opportunity should, in order to save time, communicate directly with the superintendent of the nearest station at which the desired eggs are being developed, informing him definitely regarding the number and kind of eggs wanted, the time when they are to be sent, the addresses to which they are to go, and the dates, if any, on which subsequent lots are to be shipped. The transportation companies will receive full instructions from the Commission as to the care of the eggs during shipment, and should also be asked by the consignees to make special efforts for prompt delivery.

The Commission has from time to time furnished fish eggs in response to special requests. The fact that a few universities and colleges have asked for eggs suggests that other institutions may desire such material. The only expenses to be incurred are the charges for transportation and the cost of special packing boxes ; the latter item is small and may be rendered comparatively insignificant by the return of the empty boxes to the various stations in case additional consignments of eggs are requested.

HUGH M. SMITH.

U. S. COMMISSION OF FISH AND FISHERIES.

ON A SUITABLE NAME FOR THE NEW PLANET.

TO THE EDITOR OF SCIENCE: The unique character and singular orbital position of the little planet *DQ*, recently discovered by Mr. G. Witt, give the question of its nomenclature more interest than usually attaches to such matters. Of course, the selection of a name, by courtesy and the precedent of custom, must be left to the taste and discretion of the discoverer. But it is trusted that he will pardon suggestion with regard to it, since it is a matter that other astronomers may take a legitimate interest in.

It is manifest that this little object is destined to play a rôle in our astronomy of very great importance. It opens up, at a stroke, an unexpected and royal road to the problem of the solar parallax, as well as to the nutation, the moon's mass and the aberration. Melancholy as the statement may be, it will reduce many of the existing discussions of these elements to the value of waste paper, records of futile effort.

Prominent as the object is thus likely to become, it deserves a good name. I would suggest that of Pluto, and desire to urge the claims of this gentleman to the distinction. He is the only one, of the six children of Saturn whom that unnatural father was unsuccessful in eating or otherwise destroying, who has not yet stood as godfather or godmother to some member of our planetary system. The other five, Jupiter, Neptune, Ceres, Vesta and Juno, have been worthily assigned, either to major planets or to the earlier discovered members of the Mars-Jupiter belt of asteroids. For the use of the later discoveries in this numerous group the list of available female goddesses has long since been exhausted, and now sweethearts, wives, girl-babies, and even provinces, cities and towns, are jumbled together in our lists of these objects in a ludicrous way. Will it not assist to a slight return to dignity and sanity of nomenclature to give some of the neglected male gods a chance, and destroy the unfair monopoly of the *beau sexe* in such matters? This seems a good time to begin. The body in question stands apart from the Mars-Jupiter belt, practically a stunted twin of Mars himself. Moreover, there is a certain fitness in the appellation arising from its faintness or invisibility on ordinary occasions. Pluto, under his older name, Hades, was the 'invisible' or 'unknown,' the God of Darkness. This invisibility he removes, with the helmet forged for his concealment by Vulcan, when he comes to perihelion opposition, shining then as a comparatively bright star, perhaps visible to the naked eye. This helmet, by the way, could serve as his conventional planetary symbol, if one is desired.

The addition of new asteroids to our lists has become such a nuisance that ordinarily the attachment of ridiculous names may be regarded as one of the helpful influences in discouraging further useless multiplication of these troublesome wards of astronomy. But when one is born into the solar system which gives promise of paying for its keep, some attention should be devoted to a proper christening. In the solution of the problems I have indicated, Pluto may be counted on to pay handsomely for his board and clothes.

It is hoped that the discoverer will take these

considerations, and others which could be urged, into account in his selection of a suitable name for this interesting and important little object.

S. C. CHANDLER.

CAMBRIDGE, October 31, 1898.

#### THE MINOR PLANET DQ.

THE notice in *Nature*, September 29th, quoted in *SCIENCE*, October 14th, seems to indicate a misunderstanding in reference to the orbit of the new minor planet DQ, by implying that it lies wholly within that of Mars. This is not the case; while the perihelion distance of the new planet is about 23,000,000 miles less than that of Mars, or only 12,500,000 miles greater than the mean distance of the earth, the eccentricity of its orbit is such that its aphelion distance is 37,300,000 miles greater than the perihelion distance of Mars, or nearly 10,800,000 miles greater than the aphelion distance of Mars. The periodic time of the new planet is only 643.7 days, or 1.76 years. The periods of all the other asteroids lie between 3.0 and 8.4 years.

The above numbers are derived from the elements of the orbit of DQ which I have computed from observations embracing an interval of 43 days. These elements confirm the results of Dr. Berberich.

W. J. HUSSEY.

LICK OBSERVATORY, October 27, 1898.

#### THE STRESS-STRAIN RELATIONS OF RUBBER.

IN the issue of *SCIENCE* of November 19, 1897, is a very interesting article by Professor Thurston upon the singular stress-strain relations of rubber, accompanied by the strain diagram for the same. This curve shows very clearly the peculiar and sudden increase in the value of the ratio of the stress to the strain as the point of rupture is approached.

It seems to the writer that this form of curve is to be expected as the result of the peculiar microscopic and physical constitution of rubber. It is well established that rubber consists of a mixture of two modifications of the same substance, one hard and fibrous and the other soft and viscous. These are identical in composition and similar in general properties and reactions. In other words, rubber consists of a

matrix of soft viscous matter with hard fibres imbedded and interlaced in all directions.

If this physical constitution of rubber is granted, it is clear that its elasticity must be due to the hard fibrous component, and that, therefore, these hard fibres are elastic.

If now the rubber be subjected to stress, the resistance at the beginning of the strain will be due to the forced change of shape of the individual elastic fibres, the bent ones being straightened and *vice versa*. As the strain becomes greater, however, the fibres are drawn out longitudinally and the applied force is less and less opposed by the resistance to change of shape of the fibres, and more and more opposed by their direct tension. In the extreme case, where the fibres are supposed straightened out lengthwise of the specimen, the resistance will be almost wholly due to the direct tensile strength of the fibres and the cohesion between them.

The action may be likened to that which occurs with a spiral spring. Thus, when the spring is first subjected to stress it opposes the applied force wholly by the resistance to change of shape of the wire, but later, when the stress becomes so great as to draw out the spiral, it acts less by its resistance to change of shape and more by virtue of its direct tensile strength. Finally, when the wire has become straight, its resistance is entirely a function of the tensile strength. Of course, in the rubber there are no fibres extending the length of the specimen, but consisting, as it does, of a network of imbedded and interlaced elastic fibres, it acts, in opposing the stress, like the spiral spring, first, by the resistance to change of shape of the fibres, and later by their cohesion and resistance to direct stress. That the action in the two cases is similar may be inferred from a comparison of the stress-strain diagram of the rubber given by Professor Thurston, with the data of the accompanying table of tests upon a spiral spring of one-fourth-inch diameter and one-inch length:

Load (lbs.).	Elongation (inches).
1	1
2	2.7
3	9.2
4	14.7

5	16.7
6	17.7
7	18.2
8	18.65
9	18.95
10	19.19
11	19.38
12	19.51

These data will plot a curve very much resembling the corresponding diagram for the rubber, and showing the same peculiar increase of the ratio of the stress to the strain.

Perhaps a better illustration of the supposed action would be given by the stress-strain relations of a chain with circular links. Here, after the links are flattened out by the stress, the applied force is opposed entirely by the direct tensile strength of the material, while in the early stages of the strain it is mainly opposed by the resistance to change of shape of the links.

It seems to the writer that some such simple explanation of the phenomena of the stress-strain relations of rubber naturally suggests itself from what is known of its physical constitution.

C. M. BROOMALL.

MEDIA, PA., October 17, 1898.

[ON reference to our columns, in issues of February 19th and April 15th, our correspondent will find that Professor Fessenden some years ago (See *Jour. Frank. Inst.*, September, 1896) offered this same interpretation of the singular behavior of this peculiar substance, and has, furthermore, furnished experimental illustration of artificial reproduction of the phenomena described by Dr. Thurston. The comparison between the data for the rubber and for the helical steel spring, here given, is interesting also; but it is to be observed that the rubber finds an elastic limit only at its point of rupture, while the steel exhibits a change of law on passing an elastic limit far within that limit, usually if not always, and it certainly is not composed of such a mixture of 'hard and horn-like substance with jelly-like matter in its pores,' as is described by Fessenden. Experimental investigation must still be continued in order to reveal the secret of this curious exception to the ordinary behavior of materials of construction and of commerce.—Ed. SCIENCE.]



## THE LOWER SONORAN COCHINEAL.

It is well known to residents and travellers in the Southwest that the cacti of that region furnish a kind of cochineal, but whether it was identical with the commercial insect long remained in doubt. The purpose of the present note is to separate and define the Lower Sonoran form, which has hitherto remained nameless. Four kinds of cochineal have come to my notice, as follows:

(1) *Coccus cacti*, L., of tropical Mexico and southward. The type locality is Surinam.

(2) *Coccus tomentosus*, Lam. (*opuntiae*, Licht.) of the Mexican tableland south of the Tropic of Cancer.

(3) *Coccus tomentosus* subsp. *newsteadi*, subsp. nov. of the Lower Sonoran in Arizona, Texas and northern Mexico.

(4) *Coccus tomentosus* subsp. *confusus*, Ckll., of the Upper Sonoran in New Mexico and Colorado.

The subsp. *newsteadi* was first described by Mr. R. Newstead in the *Entomologists' Monthly Magazine*, April, 1897, pp. 75-76, from specimens imported to Kew Gardens on *Opuntia fulgida* from Arizona. He intended at first to name it as distinct, but finally treated it as *tomentosus*. It is a fair intermediate between *tomentosus* and *confusus*, both structurally and geographically. It has the spines and glands about as in *tomentosus*, but averages smaller, with the antennæ usually 6-segmented, and the cottony secretion abundant, much as in *confusus*. It occurs in Wabash Creek Cañon, near Flagstaff, Arizona (*Ehrhorn*), La Puerta Rancho, in Tamaulipas (*Townsend*), Point Isabel, Texas (*Townsend*), etc.

There is no probability that either *newsteadi* or *confusus* can be used commercially. (See Bull. 3, Tech. Sec., Div. Ent., Dept. Agriculture, p. 35.)

T. D. A. COCKERELL.

MESILLA PARK, N. M., October 8, 1898.

## THE ENDOWMENT OF AMERICAN ARCHÆOLOGY.

TO THE EDITOR OF SCIENCE: I should like to make a suggestion through SCIENCE to all the universities and organized societies of the United States that a strong and systematic effort be made to celebrate that point in the age of the world called the year 2000 A. D. by a fund of \$2,000,000, whose interest would be devoted to

a study of the archæology of America. The money and the willingness to give and to use it are in plenty, and among scientific needs there is nothing that can compare. The splendid monuments of antiquity, rapidly fading away, especially in Mexico, Central America and Peru, offer the greatest rewards.

Two strong expeditions or parties ought to be kept in the field constantly. A committee of the schools and colleges should plan the work systematically, and arrange a method for making results accessible to all the public, by descriptions, models, photographs, etc. The suggestion is respectfully submitted.

W. S. PROSSER.

AUBURN, CAL.

## THE SENSE OF SOLIDITY.

TO THE EDITOR OF SCIENCE: Having had frequently the following experience, I record it with the hope that it may call forth either analogous experiences from others or some explanation.

On falling asleep with any weight in my arms I have noticed that on waking at a certain stage of drowsiness the feeling of solidity has entirely vanished. It is not only that the sensation of weight is very much dulled, but the sense of continuity in the held body is gone. Indeed, it often seems as if the hole between the parts whose contact is actually experienced could be felt. The contrast with ordinary experience is so great that it serves to bring out very effectually the fact that ordinarily in holding an object we have not only a sense of contact and of weight, but also a sense of 'filling-in' of tactile solidity or continuous extension. In the experience referred to, the contact sensations also appear to have a granular rather than a continuous character.

JOHN DEWEY.

UNIVERSITY OF CHICAGO,

October 21, 1898.

## SCIENTIFIC LITERATURE.

*The Free Expansion of Gases.* Edited by J. S. AMES, PH.D. Scientific Memoirs. New York, Harper & Brothers.

A few months ago the pleasing announcement

was made that the publication of a series of 'Scientific Memoirs' would shortly be commenced by Harper & Brothers, under the editorial direction of Professor Ames, of Johns Hopkins University. They were to relate mostly to physical science, and were to include only memoirs of first importance, and generally only such as are not very easy of access, or which are found only in some language other than English, or in a form otherwise inconvenient. Professor Ames has secured the editorial assistance of a number of well-known students of physical science, and it is gratifying to know that in the near future many of the most important memoirs relating to this great department of human knowledge, many of which have marked epochs in the history of science, will be available in a convenient and comparatively inexpensive form.

The plan will now be better understood after an examination of the first volume of the series, which bears the title given above and is edited by Professor Ames himself. It is a very attractive-looking octavo of about one hundred pages. A preface of one page is followed by Gay-Lussac's paper, read at the Institute on September 15, 1807, on a 'First Attempt to Determine the Changes in Temperature which Gases experience owing to Changes of Density, and Considerations on their Capacity for Heat.' This is an extremely interesting and important memoir, not hitherto easily accessible, although it was reprinted in Leipzig in 1896. Its principal interest is in the evidence of Gay-Lussac's anticipation of some of the most important conclusions of Joule and Thomson, which they worked out with great skill and originality nearly half a century later. Twenty years ago and earlier there was much bitter controversy over the credit due Mayer for his share in the development of the principle of the Conservation of Energy. The importance of his work is greatly enhanced by the recognition of his acquaintance with Gay-Lussac's experiments, which, says Professor Ames, is now generally admitted.

This memoir is followed by a paper upon the same subject, published in 1845, and by several others on the Thermal Effects of Fluids in Motion, the joint work of Joule and Thomson.

These constitute the most important literature on the subject and have been the foundation of the modern thermodynamics.

The editor, while adhering closely to the original, has found condensation necessary and possible in portions of the reproduction. Brief biographical sketches of Gay-Lussac and Joule are given, and, when the interest which always attaches to the personality of men who do great things is considered, it seems a pity that a page or two was not given to each of these, instead of a brief paragraph. The mere dates of birth and death, and such like, are not usually the most interesting facts relating to a human life.

This and other volumes of the series soon to appear will undoubtedly meet with a hearty welcome, for they will make it easy for all students to possess the essence of what is of the very highest importance in the literature of exact science, either current or classic.

M.

*Thermodynamics of the Steam-Engine and Other Heat-Engines.* By CECIL H. PEABODY, Professor of Marine Engineering and Naval Architecture, Massachusetts Institute of Technology, Boston, Massachusetts. New York, J. Wiley & Sons; London, Chapman & Hall. 4th ed. Rewritten and reset 8vo. Pp. 522. Price, \$5.00.

This is a new and revised, rearranged and extended issue of the well-known work of Professor Peabody, now ten years old. The book has been carefully and completely revised, to bring it up to date in theory and in current practice. Considerable new matter has been introduced and the whole has been reconstructed in such a manner as to make it substantially such as its author would have prepared as a new treatise on its subject at the present time. It is an excellent piece of technical work and undoubtedly will more than sustain the reputation which it has already acquired. This volume is a standard treatise on Clausiusian thermodynamics in our technical schools and among engineers, and, so far as the reviewer is informed, the only treatise of that school which presents any satisfactory discussion of applied thermodynamics having value for the engineer engaged in professional work relating to the heat-en-

gines. It is a practitioner's and student's text-book in that system, as Wood's Thermodynamics is the representative for the same classes of readers of the Rankinian method.

In the new book a considerable addition has been made to the discussion of the gas-engines, which includes the latest information regarding producer-gas and the oil-engines, and closes with a discussion of the Diesel motor, now attracting, deservedly, much attention among members of the engineering profession as having attained unusual results by an exceptionally successful attempt to reproduce ideal thermodynamic conditions in an approximation to the Carnot cycle. Its best work is reported at 223 grms. of petroleum per hour for 19.2 horse-power, equal to three-fourths of a pound of coal per horse-power-hour. The best steam-engines, even of many times this power, consume seldom less than double this figure. The latter half of book is devoted mainly to the subjects of steam-engine testing, compound and other multiple-cylinder engines, the influence of the cooling effect of cylinder-walls and steam-engine economy generally. Considerable new matter appears in these sections. The latest investigations, as those of Hall, and of Callendar and Nicholson, are detailed, with admirable success in condensation. Recent and notable reports on steam-engine trials, as of the famous engines of Leavitt and of Sulzer, of Schmidt and of Rockwood, and of the steam-turbines, are summarized and the data are tabulated. The more elaborate scientific tests of the 'experimental engines' of the Massachusetts Institute of Technology and of Sibley College at Cornell University are presented in their essential details, while the discussions exhibiting the ideal and the real effects of the operations of compounding, of superheating and of jacketing, as influencing efficiency and economy of steam, heat and fuel, are most instructive and valuable. The final chapters are devoted to brief discussions of compressed-air machines and apparatus of refrigeration.

This book is a rarely good work and is excellently published. It is one which no member of the engineering profession dealing with the heat-engines can safely leave out of the list of his working library, and no student desiring

more than a superficial knowledge of its subject should fail to read with special care.

R. H. THURSTON.

*Prismoidal Formulæ and Earthwork.* By THOMAS U. TAYLOR, Professor of Applied Mathematics in the University of Texas. New York, John Wiley & Sons. 8vo. Pp. 102 and one plate. Price, \$1.50.

The historical and theoretical discussions of this volume will be of especial interest and value to civil engineers on account of the extensive use of the prismoidal formula made by them in earthwork calculations and because the engineering handbooks generally avoid such discussions. There are probably few engineers who know that the prismoidal formula is applicable to the volume of a sphere, or to any segment of a sphere, as also to ellipsoids and paraboloids. The author shows that its application is wider even than this, and that the volume of any prismoid whose sectional area can be expressed by a cubic function of its distance from any reference section is found by adding the areas of the two bases to four times the area of the mid-section and multiplying this sum by one-sixth of the length. He also gives demonstrations of the two-term prismoidal formulas of Koppe, Hirsch and Eehols, and discusses their limitations and uses in a very interesting manner. Although these two-term formulas involve but two sections instead of three, it does not appear that they are more convenient in practice than the common formula.

The author attributes to Newton the honor of the discovery of the prismoidal formula, and states that it is given in the *Methodus Differentialis*, 1711. An examination of this paper of Newton fails, however, to substantiate this statement, and it is to be regretted that the author did not quote the words in which he claims that the theorem was announced. His reference to Simpson is also unsatisfactory, although he points out that Simpson's rule for the quadrature of a curve from three ordinates is the same in form as the prismoidal formula. With these exceptions the historical matter of the volume is more complete than can be easily found elsewhere. Over one-half of the book is devoted



to computations for excavations and embankments of railroads and canals, and the method of using the prismoidal formula by means of corrections applied to the volumes as determined from average end areas is developed at length. It is to be regretted that the author uses the Latin word formulæ instead of the English word formulas. M. M.

#### SCIENTIFIC JOURNALS.

*Botanical Gazette*, October: Mr. J. H. Schaffner, in a paper on 'Karyokinesis in the root tips of *Allium Cepa*,' states that he finds the root tips of *Allium Cepa* very valuable objects for the study of nuclear division. The details he illustrates upon two handsome plates, because, he says, "accounts and figures of karyokinesis in plant cells are very scarce, and the so-called diagrammatic or schematic figures and descriptions given in most text-books are but a poor guide for the student and young investigator." A student of Mr. Schaffner's, Mr. Edward L. Fulmer, writes on the 'Cell division in pine seedlings,' illustrating the process by two plates. Mrs. Fannie D. Bergen continues, in two installments, her list of 'Popular American Plant Names.' These papers are reprinted from the *Journal of American Folk Lore*. Dr. Byron D. Halsted has a short discussion of the newer aspects of botany, especially the ecological ones. The paper summarizes some remarks before the National Educational Association at Washington. Dr. C. F. Millsbaugh contributes 'Notes and new species of the genus *Euphorbia*,' illustrated by his admirable figures. A biography of Joseph F. Joor, with portrait, and a short sketch of the DeCandolle family are written respectively by Mr. J. B. S. Norton, of the Missouri Botanical Garden, and Dr. G. E. Stone, of the Massachusetts Agricultural College. Mr. Clarence J. Elmore has studied the question of polyembryony in certain wild species of *Allium*. He finds the contents of the embryo sac exceedingly variable, the frequent absence of antipodals being especially noteworthy. In Open Letters, Dr. Robinson disavows responsibility for 'The American Botanist,' which was dated without authorization from the Gray herbarium; and Mr. Cockerell has a short letter on the nomenclature of *Eschscholtzia Mexicana*

and *Philibertella heterophylla*. Reviews are given of Barnes's 'Plant Life;' Britton and Brown's 'Illustrated Flora,' volume three; 'The Ninth Report of the Missouri Botanical Garden;' part two of Durand and Schinz's 'Flora of Africa;' Courechet's 'Text-book of Botany,' and Schneider's 'Guide to the Study of Lichens.' Twelve pages of Minor Notices of books and papers, Notes for Students, and News complete an unusually varied number.

#### SOCIETIES AND ACADEMIES.

BIOLOGICAL SOCIETY OF WASHINGTON—295TH REGULAR MEETING, SATURDAY, OCT. 22.

DR. T. S. PALMER mentioned the reported occurrence in Patagonia of a living representative of the extinct *Mylodons*.

Mr. G. H. Hicks exhibited specimens of *Pinus torreyanus* and spoke of its extremely restricted distribution.

Dr. J. N. Rose presented a paper on his 'Proposed Arrangement of the subfamily Agaveæ,' stating that it was partly based on his four months' study of the group in its home in Mexico. The paper, which was illustrated by specimens, photographs and drawings, was particularly interesting from the fact that living types of all the genera were shown.

Mr. F. A. Lucas spoke on 'The Fossil Bison of North America, with description of a new species' for which the name *Bison occidentalis* was proposed. The horn cores of this species were of moderate size, although much larger than those of the existing species; their circumference at base was equal to, or slightly greater than, length along upper curve; they were sub-cylindrical in section and regularly curved upward and backward. The type from Fort Yukon was No. 4047 of the collections of the U. S. National Museum. The species was readily distinguished from *B. antiquus*, with which it had been confounded by the fact that in *antiquus* the horns stood at right angles to the longitudinal axis of the skull and were not directed backwards.

Mr. A. J. Pieters read a paper on 'Problems of Aquatic Vegetation,' stating that aquatic plants, especially the unicellular algæ, are the primary source of food supply in the lakes. The relation between the higher plants and the low

forms that feed on them are but imperfectly understood, although we know that millions of minute animals and plants make a home among *Characeæ*, *Naias* and other phanerogams.

The effect of the growth and decay of the larger plants upon the algæ is probably of much importance, but definite information is wanting. Our conception of the relation between the phanerogams, the medium in which they grow, and the bottom may be somewhat changed if the experiments of Hochreutener on the flora of Lake Geneva can be confirmed. He found that the species studied absorbed eosin solution much more readily by their roots than by their leaves. If this proves to be true the study of bottom samples will be more important than before.

The most important problem in fresh-water algology is the study of the rate of growth of unicellular forms, and all the questions necessarily connected with this.

Specimens were shown that illustrated the effect of depth and local conditions of environment on the habit of species. Rootstocks, tubers and bulbs were shown and attention was called to their importance in the questions concerning the propagation and reproduction of aquatic.

Mr. Gilbert H. Hicks read a paper on 'The Effect of Certain Fertilizers on the Germination of Seeds.' Attention was called to the losses which often result in practical farm operations from the failure to secure a 'stand' of certain crops, due to the excessive or improper use of chemical fertilizers which often prevent or retard the germination of the seeds.

The paper was based upon experiments conducted in one of the greenhouses of the Department of Agriculture upon seeds of wheat, lettuce, radish and crimson clover. In one series of greenhouse 'flats' seeds were planted in rows directly in contact with the chemical; in another series the upper stratum of soil was mixed with the same amount of chemical used in the previous case and the seeds were planted in this stratum; otherwise the conditions of growth were exactly the same. Checks were also conducted at the same time. The plant food elements—nitrogen, potash, phosphoric acid and lime—were used in the forms of ni-

trate of soda, muriate of potash, dissolved bone black and powdered oyster shells. In addition to these a 'balanced' fertilizer, consisting of a mixture of the above ingredients, was employed.

The experiments proved to be of much interest and appeared to warrant the following conclusions:

1. That muriate of potash and sodium nitrate used as fertilizers in strengths of one per cent. or more are very detrimental to the germination of seeds, whether applied directly or mixed with the soil.

2. That fertilizers composed of phosphoric acid or lime are much less injurious to germination than sodium nitrate or muriate of potash, and if not used in excess may be harmless.

3. That commercial fertilizers should not be brought into direct contact with germinating seeds.

4. The effect of treating seeds with chemicals before planting is no index to the action of those chemicals when applied as manures to the soil.

5. That the chief injury to germination from chemical fertilizers is effected upon the young sprouts after they leave the seed coat and before they emerge from the soil, while the seeds themselves are injured only slightly or not at all.

6. It is highly improbable that potash, phosphoric acid, nitrogen or lime used as fertilizers actually favor germination.

F. A. LUCAS,  
*Secretary.*

BIOLOGICAL SECTION, NEW YORK ACADEMY OF SCIENCES—MEETING OF OCTOBER 10, 1898.

In the absence of Professor Wilson, Professor Osborn in the chair.

Professor Osborn referred to the loss sustained by the Academy and the biological sciences in general through the death of Professor Baur, of Chicago, and Dr. Arnold Graf, of New York.

Following the usual custom, the meeting was devoted to reports given by various members of their summer's work.

Professor Osborn described the different museums which he visited in Europe, giving a brief account of the good and bad points of each. At Stuttgart he saw a unique and undescribed fossil, *Hyrax*, which Professor Fraas very generously gave him the pleasure of describing. The

description was presented at the meeting of the British Association in Cambridge.

Professor Osborn was followed by Professor Britton, who gave a *résumé* of the work accomplished during the summer on the building and grounds at the Botanic Garden in Bronx Park.

Professor Dean reported on a few results on the embryology of the Hag Fish, which he thinks is similar to that of the shark. He also described the appearance of a Central African Lung Fish (*Protopterus*), which was sent to him in a ball of dried mud.

Dr. O. S. Strong and Mr. H. E. Crampton reported briefly of the nature of the work accomplished at the Marine Biological Laboratory at Woods Holl, bringing out particularly the fact of the cordial relations between the Fish Commission investigators and those of the Laboratory.

Mr. N. R. Harrington related some interesting experiences in connection with his expedition to the Nile valley in quest of *Polypterus bishir*. The expedition, which was made possible by the generosity of Mr. Chas. H. Senff, was undertaken by Mr. Harrington and Dr. Reid Hunt. As guests of the Egyptian government they enjoyed unusual advantages in securing their ends, but only after repeated trials and discomforts and many disappointments did they finally get the fish.

Other brief reports were made by Professor Lloyd (on the botanic gardens of Germany), Dr. Brockway and Mr. Calkins.

GARY N. CALKINS,  
*Secretary of Section.*

GEOLOGICAL CONFERENCE OF HARVARD UNIVERSITY, OCTOBER 11, 1898.

MR. A. W. GRABAU opened the work for the year with a paper on 'Some Methods of Stratigraphical Field-work.' He illustrated practical suggestions on collecting fossils and measuring sections by cases drawn from his detailed study of the Eighteen Mile Creek section, New York. Mr. J. R. Healy described the features studied by the Harvard mining class during its summer visit to the Lake Superior mining region. The party examined the underground workings of thirteen mines, and the open-cut workings in the extensive iron-ore deposits of the Mesabi Range.

OCTOBER 18, 1898.

DR. F. P. GULLIVER delivered a paper on the 'Physiography of the Ural Mountains, and illustrated it with numerous lantern views. The Great Plain of Russia, a plain of denudation, rises gently and constantly from the center of the country into the Urals. It has been traced upon the folded and faulted Devonian strata of the outer ranges, and also upon the more intensely plicated Carboniferous beds and upon the granite of the Central Urals. In addition to this, Dr. Gulliver observed remnants of peneplains at two other distinct levels. The relative attitudes of these levels indicate, first, that the Ural Mountains have been elevated as a whole in the form of an arch with a north-south axis; and second, that this elevation, and the dissection consequent upon it, occurred in at least three distinct stages.

The physiographic features noted on the western side of the continental divide are repeated on the eastern side, with the addition of a steep fall-off from the Ilmen Mountains to the great Siberian peneplain. Richtofen holds that this is a sea scarp cut by the same sea that carved the Siberian plain. Others believe that it is a fault scarp which marks the disjoining of the Siberian plain from one of the upper levels of the Urals.

J. M. BOUTWELL,  
*Recording Secretary pro tempore.*

#### NEW BOOKS.

*The Psychology of Peoples and its Influence on Their Evolution.* New York, The Macmillan Company. 1898. Pp. xii + 236.

*The Fishes of North and Middle America.* DAVID STARR JORDAN and BARTON W. EVERMANN. Washington, Government Printing Office. 1898. Part 4. Pp. xxx + from 1241-2183.

*Laboratory Exercise in Anatomy and Physiology.* JAMES EDWARD PEABODY. New York, Henry Holt & Co. 1898. Pp. x + 79.

*Observations of the Planet Mars during the Opposition of 1894-95, made at Flagstaff, Arizona.* PERCIVAL LOWELL. Annals of the Lowell Observatory, Vol. I. Boston and New York, Houghton, Mifflin & Co. 1898. Pp. xi + 391.



# SCIENCE

EDITORIAL COMMITTEE: S. NEWCOMB, Mathematics; R. S. WOODWARD, Mechanics; E. C. PICKERING, Astronomy; T. C. MENDENHALL, Physics; R. H. THURSTON, Engineering; IRA REMSEN, Chemistry; J. LE CONTE, Geology; W. M. DAVIS, Physiography; O. C. MARSH, Paleontology; W. K. BROOKS, C. HART MERRIAM, Zoology; S. H. SCUDDER, Entomology; C. E. BESSEY, N. L. BRITTON, Botany; HENRY F. OSBORN, General Biology; C. S. MINOT, Embryology, Histology; H. P. BOWDITCH, Physiology; J. S. BILLINGS, Hygiene; J. McKEEN CATTELL, Psychology; DANIEL G. BRINTON, J. W. POWELL, Anthropology.

FRIDAY, NOVEMBER 18, 1898.

INERTIA AS A POSSIBLE MANIFESTATION OF THE ETHER.

## CONTENTS:

<i>Inertia as a Possible Manifestation of the Ether:</i>	
PROFESSOR CARL BARUS.....	681
<i>The Fauna and Flora about Coldspring Harbor, L. I.:</i>	
PROFESSOR CHAS. B. DAVENPORT.....	685
<i>The Nernst Lamp:</i> H. MONMOUTH SMITH.....	689
<i>Botany at the Anniversary Meeting of the American Association (II.):</i> DR. ERWIN F. SMITH.....	690
<i>Surveys of the Gateways to Alaska.....</i>	700
<i>Notes on Inorganic Chemistry:</i> J. L. H.....	701
<i>Botanical Notes:—</i>	
<i>The Flora of the Upper Susquehanna; Bombay Grasses:</i> PROFESSOR CHARLES E. BESSEY.....	702
<i>Scientific Notes and News.....</i>	703
<i>University and Educational News.....</i>	706
<i>Discussion and Correspondence:—</i>	
<i>The 'Bipolarity' Hypothesis:</i> PROFESSOR W. A. HERDMAN. <i>Peridinium and the 'Red Water' in Narragansett Bay:</i> DR. A. D. MEAD. <i>The Proposed Catalogue of Zoological Bibliography:</i> DR. W. H. DALL. <i>The Nernst Light:</i> H. C. COOPER. <i>The Day of the Week:</i> PROFESSOR GEO. C. COMSTOCK. <i>Northern Rocky Mountain Glaciers:</i> GEO. BIRD GRINNELL.....	707
<i>Scientific Literature:—</i>	
<i>Shaler's Outlines of the Earth's History:</i> PROFESSOR ISRAEL C. RUSSELL. <i>Lassar-Cohn's Die Chemie im täglichen Leben:</i> DR. FERDINAND G. WIECHMANN. <i>Wade's Introduction to the Study of Organic Chemistry:</i> J. E. G.....	712
<i>Scientific Journals.....</i>	716
<i>Societies and Academies:—</i>	
<i>The American Mathematical Society:</i> PROFESSOR F. N. COLE. <i>Biological Society of Washington:</i> F. A. LUCAS. <i>Entomological Society of Washington:</i> DR. L. O. HOWARD. <i>Torrey Botanical Club:</i> E. S. BURGESS. <i>Botanical Seminar of the University of Nebraska. Academy of Science of St. Louis:</i> PROFESSOR WILLIAM TRELEASE. <i>Alabama Industrial and Scientific Society:</i> PROFESSOR EUGENE A. SMITH.....	717
<i>New Books.....</i>	720

IN the *American Journal of Science* for October I described certain experiments on the compression of coagulated jelly, to which I am inclined to attach some importance, since they establish a case of well defined persistent motion of material bodies in a highly viscous (solid) medium, as the sheer result of the breakdown of stress in the medium in question, and quite without the agency of any force 'acting at a distance.' I ask the reader's indulgence if I recall the main features of these experiments here, for the remarks which I propose to make in the present communication are to be based directly upon them and would lose their point in a mere reference.

Given a thread of firmly coagulated (10%–20%) gelatine solution *b*, Fig. 1, 10–20 cm. long, between terminal threads of mercury *a* and *c* in a fine bore ( $\frac{1}{8}$  mm.) strong capillary tube (not shown in figure). The upper thread is fixed; the lower is movable and transmits the pressure of a strong force pump. As pressure increases, it will be found that the originally convex meniscus in Fig. 1 is gradually more and more sharpened conoidally upward, until the unstable figure 2 is reached, after which, as in 3, a small projectile, usually round and often less than  $\frac{1}{10}$  mm. in diameter, is shot upward 10–20 cm., against gravity and against

MSS. intended for publication and books, etc., intended for review should be sent to the responsible editor, Professor J. McKeen Cattell, Garrison-on-Hudson, N. Y.

the relatively enormous viscous resistance of the coagulated colloid. The motion of the projectile is extremely rapid at first (say several *met./ sec.*, or more), but gradually slows down, until after 5-10 minutes it has been reduced to the merest creeping visible in the telescope. This phenomenon

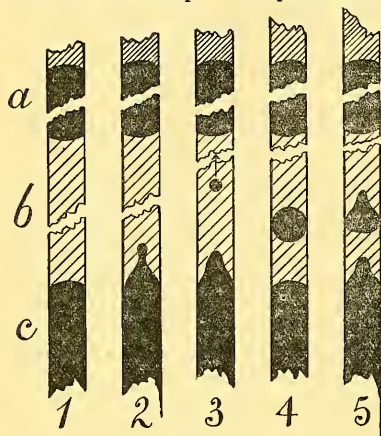

FIGS. 1-5

is repeated on increasing the pressure, but even at the same pressure many projectiles may be successively shot off to be distributed along the axis of the column. Later projectiles frequently actuate the earlier ones to renewed motion (5-10 cm.) without touching them and even after the latter have come to rest.

An interesting case is the *drop* of mercury purposely broken off ahead of the meniscus, as shown in Fig. 4, while the colloid was yet liquid. After thorough coagulation the effect of pressure is shown in Fig. 5. The drop soon takes a conoidal form,\* and thereafter shoots off projectiles of mercury from its apex, being continually replenished by bombardment from the meniscus below, changing form but remaining

\*The curvature due to stress is, of course, superimposed on the curvature of the globule.

in place. On another occasion, however, the drop deliberately exploded, being thereafter represented by some dozen small projectiles distributed through the lower 10 cm. of the colloidal column. The top meniscus neither moves nor changes form.

On gradually removing pressure the experiment is reversed, *i. e.*, the projectiles move in a somewhat similar manner back toward the (lower) meniscus out of which they originated. But the march back is not complete, showing that much energy is wasted in virtue of viscosity.

*Experiment explained.*—My explanation of these occurrences is as follows: The phenomenon throughout is elastic in character. The lower end of the colloidal column, loaded with a uniformly distributed pressure, yields like an elastic disc—least at the edges where it is sustained by the walls of the capillary tube and most near the center; for the jelly is not quite incompressible (compressibility of the order of about  $10^{-6}$  per atmosphere). The column is telescopically sheared, so to speak, and gives way symmetrically with respect of the axis. When stress exceeds the limits of rupture the strain breaks down, as indicated by the motion of the mercury projectile.

Consider the intrusion of the mercury globule for a moment; ahead of it there is always the continuous overstrained solid colloid; behind it discontinuous or triturated colloid, the *débris* of the original continuous column. The former transmits stress like a solid, locally showing definite rigidity; the latter transmits hydrostatic stress. So the projectile is pushed forward by rear-end pressure communicated by the mercury, but pushed forward at a gradually retarded rate; for, though the intensely viscous quasi-liquid not exactly

“...drags with each remove a lengthening chain,”

it must certainly make its way through an ever-lengthening channel, which eventually,

in fact, seals itself quite up again. The marvel is that the projectile gets so far after the first breakdown. It could not do so if the main part of its motion were not swift, indicating a very steep pressure gradient. At all events, the time soon arrives (5-10 minutes) when the elastic resistance of the strained colloid ahead of the projectile is in excess of the remnant of hydrostatic pressure behind it, and the projectile stops. It would gradually stop even without the re-cementation of the triturated channel, but the fact that the antics begin all over again with the next projectile is proof (were it needed) that the column has actually resumed continuity. It again gives evidence of definite rigidity.

Other things I would like to add, but I have already trespassed too far.

*The ether.*—Now, whenever one finds out anything about jelly—something of an order just a little above the kitchen I mean—one has the right to traipse in the footprints of well-known great thinkers and approach the ether. I am not given to denying myself, so I shall have my ether, which, just like the jelly, is to be solid or liquid under like conditions, as I please. Nobody ever caught such an ether before (though it has been fished for), which, to repeat, shall be either continuous and rigid or discontinuous, triturated, virtually rigid, as the conditions warrant. Note that since it *must* be elastic\* it may as well be *solid*, without invoking essentially new conditions.

Beyond this my ether is to have no respectable properties at all, except that if broken it seals itself up again, as all ethers do, particularly under pressure, and that it resists breakdown as this becomes more rapid. It is to be nearly incompressible, brittle, and in the first instance (by no means the last) free from inertia. Such

an ether can transmit stress instantaneously like a stick, or, better, like that imponderable instrument with which people poke fun at us. The ether cannot of itself vibrate. Though incompressible, it may become virtually so by enclosing triturated regions, particularly in the pressure of matter.

*The body.*—With these admissions, I will examine, for a moment, the relations of this ether to a physical body, regarded as a grouping of ultimate particles fixed relatively to each other. I shall use this body chiefly to produce the triturated regions, with a view to dropping\* it from the considerations *altogether*, if it can be made to appear non-essential.

Let there be given a region free from force. Let a body be imbedded in the solid (continuous) ether, permeating the region and permeating the body intramolecularly as well. In the first instance, inertia as a physical property is to be attributed neither to the body nor to the region.

Let the body be moved by an impulse from without. Immediately there will be discontinuous ether capable of transmitting hydrostatic pressure *behind* the body, or, better, behind each ultimate particle of the body, while the sheared continuous ether pervades in front of it, in the direction of motion.

Now, suppose that the trituration in question is a marked occurrence, accompanied, therefore, by increase of volume. There must then be a simultaneous manifestation of hydrostatic pressure in the triturated region greater, as the surrounding solid ether is more rigid.

*Regions of triturated ether.*—Now, consider the triturated region (however produced) by itself, supposing no material ultimate particles present therein.†

\*The remarks in the *American Journal* refer to this body in place, in the manner set forth by the above text.

†I have also carried out these ideas, keeping the

\* It is unfortunate that all ethers must be elastic. This really introduces the whole of our molecular machinery over again and indicates nothing ultimate.



As the case stands (no inertia), the region is the fund of the whole energy imparted by the impulse. In other words,  $fpdv$  can not vary for the triturated region if no new impulse is at hand. But the ether, like the jelly, is supposed to be *self-sealing* under pressure; *i. e.*, the tendency to make  $fpdv$  vanish. Hence, in homogeneous ether the triturated region, if alone, can not be at rest;\* it may either break down fresh continuous ether on one side as fast as it seals itself up again on the diametrically opposite side, always retaining  $fpdv$  constant; or it may seal internally while it increases in area externally, forming an ever-widening closed shell whose energy per  $cm^3$  eventually obeys the orthodox law; if a body were present the region might become distributed among its vibrating molecules, etc.

*First law of motion.*—Now, as the breakdown progresses from layer to layer *successively*, the region will seal up soonest where it broke down first; for the pressure is constant throughout the region. Hence the motion of the region must be *uniform* and *linear* in the direction of the impulse. This seems to me to be an approach to Newton's first law. Rest, though impossible for a single region, may occur in a cluster of regions (see below), the individuals of which move.

Since energy imparted to the region in any other direction must act in the same way, I conclude that the new velocity may be compounded vectorially with the initial velocity.

*Second law of motion.*—The next question

body in place, with each of its ultimate particles associated with triturated ether, analogously to the mercury projectiles in the above experiment. But since my remarks can be made without reference to material molecules, I have preferred to drop the body (unwisely perhaps) as an unnecessary complication.

\*The rate of motion varies with the fineness of trituration, as will be indicated below; *i. e.*, it varies with the pressure in the region.

at issue is this: Can the region be made to behave like a massive body, even though made of stuff destitute of inertia. For ulterior reasons it is undesirable to change the volume of the region appreciably; any energy can, nevertheless, be stored within, by increasing the fineness of trituration. The effect of this is to increase the internal pressure and to increase proportionally, at the same time, the rate of recementation behind (in the direction of motion) and the rate of breakdown in front. Hence the region may be treated as moving faster in proportion as the energy imparted by the impulse is greater. Sealing is supposed to occur more rapidly under pressure, and the two rates must keep pace with each other if there is to be conservation of energy.

The resistance to increased breakdown would thus vary in the first place with the change per second of the velocity; for a regular succession of impulses, *i. e.*, a constant force, must produce a correspondingly regular succession of increments of velocity, or constant acceleration; it would vary in the second place with the total *front* of ether broken down. The latter quantity is thus left to account for mass. For simplicity let the regions occur clustered like the molecules of a body, and be all of the same spherical volume. Then the resistance to breakdown will vary, *caet. par.*, with their number per unit of volume, or, in other words, with the *density of distribution* of the regions within the body. This seems to be an approach to Newton's second law regarded as a manifestation of the ether.

A body built up of such similarly circumstanced regions would virtually be a massive body.\* Each component region, if not

\*The third law of motion, inasmuch as it deals with the occurrence of stress between two or more regions, must ultimately culminate in an explanation of gravitation. One naturally shrinks from touching this, though I hope to consider the reflection and collision of the regions at some other time.

interfered with would maintain a constant rate of breakdown, implying constant velocity, as already explained.

CARL BARUS.

BROWN UNIVERSITY,  
PROVIDENCE, R. I.

*THE FAUNA AND FLORA ABOUT COLDSRING HARBOR, L. I.*

THE Biological Laboratory of the Brooklyn Institute of Arts and Sciences, located at Coldspring Harbor, Long Island, has during the nine years of its existence accumulated an important lot of information concerning the animals and plants of the vicinity. Especially during the present season has the attention of the investigators been in great part directed towards a biological survey of the locality. Of the survey the following may be regarded as a preliminary report.

spring Harbor and Oyster Bay receive at their upper ends fresh-water streams of considerable volume, and at intervals along their coast line, smaller ones. Consequently the density of the water is low, being about 1.019 at flood-tide near the surface in the middle of the outer harbor. Coldspring Harbor is a sunken river valley with abrupt fjord-like sides, which extend back into the country for three miles from the upper end of the Harbor. In the valley runs the stream of Coldspring Creek, which expands at three different levels into broad, deep ponds, connected by waterfalls and shaded by dense foliage. The woods which rise from these ponds are densely grown with a rank vegetation and are rich in the fleshy fungi which accompany a moist climate.

Coldspring Creek, flowing, laden with silt, into the upper end of the Harbor, has formed there, with the aid of the sea, a sand spit which nearly cuts off an inner basin, about 3,000 feet long by 2,000 feet wide, from the outer harbor. The water of the inner basin is decidedly brackish, at high tide varying from 1.006 to 1.016 at the surface and from 1.006 to 1.018 at the bottom. The passage from the inner basin to the Harbor is only 200 to 300 feet wide at low tide, and through this 'gut' the water flows at times with great rapidity. The mean range of tide is 7.3 feet. The inner basin, which is gradually silting up, exposes about half of its bottom at every low tide for an hour or so. In the outer harbor, above the entrance of Oyster Bay, the water is uniformly 15 to 18 feet deep at low tide. Immediately below Oyster Bay entrance is a bar with only 6 to 10 feet of water at low tide. At the eastern end of this bar is a channel 72 feet deep. Outside the bar the water deepens steadily towards the middle of the sound.

The steep sides of the harbor are piles of glacial drift, full of clay, siliceous sand, gravel and boulders of varying size. This

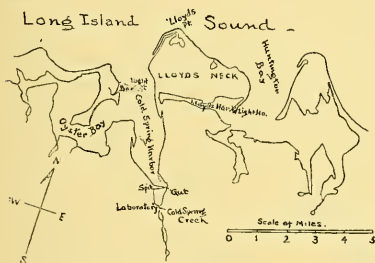

The conditions at Coldspring Harbor are as follows: The Harbor is a body of water about five miles long and from one and a quarter miles to a quarter of a mile wide, which opens at its broader end into Long Island Sound, itself an inland sea, about eighty miles from where it debouches into the open ocean. Opening into Coldspring Harbor at about the middle of its western side is Oyster Bay, a tortuous body of water running back some six or seven miles and having a breadth varying from one and a-half miles to half a mile. Both Cold-

determines the prevailing character of the shore line, sandy or gravelly beaches with boulders extending into deep water and most abundant at the base of the worn-off bluffs.

Mud flats are common, but for the most part underlaid by sand at a depth of one to three feet. A mud flat extends from parts of the sand spit at the level of mean low tide. No rock occurs in place, but on many headlands the accumulated boulders at the base of the bluffs form an extensive rock-work. At intervals the shore line of the harbor is diversified by salt meadows, partly enclosed salt ponds and shallow 'harbors' and bays.

#### THE FAUNA ABOUT COLDSRING HARBOR.

The situation of the laboratory is unique in its combination of immediately accessible faunas of the sea, fresh-water and woodland, all very rich in individuals and species. Some of the commoner or more interesting forms may here be enumerated. The list may be prefaced with the statement that, owing to the fact that the Harbor is so nearly an inland sea, there are few stragglers in the marine fauna; what one finds belongs to the place—its presence is determined by the local environment.

*Protozoa*: Volvox and Stentor are extremely abundant in the lakes.

*Spongiae*: *Spongilla* (?) in the stream connecting the lakes. The boring sponge, *Clione sulphurea* Desor, is abundant. There are various other species in the Harbor, unidentified.

*Anthozoa*: The coral *Astrangia Danæ* is one of the common products of dredging at the lower end of the Harbor. Three species of sea anemones are common. Among them *Sargartia leucolena* and *Halocampa producta* are common in the sand.

*Hydrozoa*: Hydra is common in the lakes. Of the hydroid stocks may be mentioned *Obelia*, *Campanularia*, *Podocoryne*,

*Hydractinia*, *Plumularia* and *Bougainvillia*, which are abundant, and *Perigonimus*, *Eudendrium* and *Tubularia*, which are less common. Jelly-fishes of several other species occur in the tow.

*Ctenophore*: *Mnemiopsis Leidyi* has been abundant throughout the present summer.

*Echinoderma*: *Asterias forbesii* is very abundant, especially on the outer bar. Its numerous abnormalities have attracted some attention this season. The sea-urchin, *Arbacea punctulata* Gray, is found occasionally in dredging, but is not abundant. The Holothurian *Synapta Girardii* is abundant in the sand spit near the laboratory and is sometimes found in the tow. *Synapta roseola* Verrill also occurs. The tow frequently contains star-fish larvae.

*Balanoglossus*: A form of this genus, apparently different from *B. Kowalevskii*, occurs in the sand spit.

*Mollusca*: The shores of Long Island have long been famous for the richness of their molluscan fauna. About 100 species from the Harbor have been identified\* during the present season. Among the more abundant genera are *Chiton*, *Fulgur*, *Sycotypus*, *Tritia*, *Ilyanassa*, *Urosalpinx*, *Eupleura*, *Neverita*, *Littorina*, *Teredo*, *Xylotrya*, *Mya*, *Solen*, *Macra*, *Venus*, *Liocardium*, *Nucula*, *Scapharca*, *Mytilus*, *Modiola*, *Pecten*, *Anomia*, and the semi-domesticated oyster. Slugs of various species are common in the woods. Few of the various nudibranchs have been identified. Squids' eggs are occasionally dredged and adult squids occur, although they are irregular in their appearance.

*Bryozoa*: Among the common marine forms may be mentioned *Crisea eburnea*, *Bowerbankia*, *Aleyonidium hispidum* and *Bugula turrita*. In the lakes *Pectinatella magnifica* Leidy is abundant. *Pedicellina* has been found.

*Tunicata*: *Botryllus* is common. *Molgula*,  
\* Chiefly by Mr. Francis N. Balch.



probably of two species, is obtained abundantly. *Perophora viridis* is found on algæ from near the Sound. Common also is *Amarœcium constellatum*, found at the Harbor's mouth.

*Platyhelminthes*: Fresh-water *Turbellaria* are abundant. *Bdelloura propinqua* is common on *Limulus*. *Apoblena (Distomum) appendiculatum*, which occurs abundantly in Copepods here, has been made the subject of a memoir by Professor Henry S. Pratt, of Haverford College. The large Nemerteans, *Cerebratulus Leidyi* and *C. lacteus*, occur in the sand spit. Of Annelids over fifteen species have been identified, chiefly by Dr. J. I. Hamaker. *Nereis virens*, although near the southern limit of its area of distribution, is extremely abundant. The more southern *Nereis limbata* is abundant. Other common species are: *Arabella (Lumbriconereis) opalina*, *Euglycera (Rhincobolus) dibranchiata*, *Clymenella torquata*, *Amphitrite ornata*, *Chetobranchus sanguineus*, *Cirratulus grandis* and *Serpula dianthus*.

*Rotifera*: These organisms are extremely abundant in the lakes, but no species have been identified.

*Sipunculoidea*: *Phascolosoma* occurs on a sand spit near the lighthouse at the entrance to Lloyd's Harbor.

*Entomostraca* of many kinds are abundant in the lakes. A few minutes' towing will collect a countless number of individuals of *Daphnia*. Of the marine copepods *Acartia* is one of the most abundant. Many *Balanidæ* occur and their larvæ are common on the tow.

*Amphipoda*: *Caprella acutifrons*, new variety, can be obtained by the pint in the 'gut.' *Talorchestia longicornis* is abundant on the sand spit.

*Isopoda*: *Bopyrus* is very common on prawns, *Idothea irrorata* on eel grass, and the *Oniscidæ* about the springs.

*Podopthalmata*: *Squilla empusa* is common at the sand spit and *Mysis* in the tow. Among

the decapods there have been identified *Homarus vulgaris*, *Callinassa* and *Gebia*, which occur in the sand spit. Numerous hermit crabs occur. Other crabs are unusually abundant. The dredge or tangle brings up from the region of the outer bar *Libinia caniculata*, very large and numerous; *Libinia dubia*; *Callinectes hastatus*, not common; *Platyonichus ocellatus*, or 'lady crab'; *Panopeus Sayi*; *P. depressus*; *Cancer irroratus*. On the shores fiddler crabs of two or three species abound.

*Pycnogonidia*: *Pallene empusa* Wilson is common.

*Limulus* is abundant on the sand spit, near the laboratory.

*Insects*: The moist woodland about the lakes and springs offers a remarkably rich collecting ground for insects. One of the most striking species, on account of its size and abundance, is a form of the cricket-grasshopper, *Ceuthophilus*

*Vertebrates*: Some twenty species of fish have been identified.\* Dogfish and sand sharks seem to be common. The stomachs of nine of the former have been examined during July of this year, and an aggregate of eleven squillas, four spider crabs, four hermit crabs, three other crabs, several teleosts and a squid have been found in their stomachs.

Newts and frogs are common. Many tortoises, snakes, water and land birds and mammals are seen by the most casual observer.

I am indebted to Dr. D. S. Johnson, instructor at the Laboratory, for the following description of

#### THE FLORA ABOUT COLDSRING HARBOR.

The physiographic conditions of this region are considerably varied, as has been noted above. On the outer coasts of the north side of the island are extensive sandy beaches, almost or completely washed over by the sea during hard storms.

\* Chiefly by Mr. Francis B. Sumner.

Just above the reach of the ordinary tides these beaches are partially covered with *Spartina juncea* interspersed with *Rhus toxicodendron*, *R. copallina* and *Lathyrus maritimus*, while *Arenaria peploides*, *Salsola kali*, *Cakile maritima*, *Opuntia Rafinesquii* and *Solidago sempervirens* are among the other halophytes and xerophytes met with. *Juniperus Virginiana*, *Myrica cerifera* and *Prunus maritima* are the only considerable shrubs found here.

On the more barren spots farther from the spray numerous tufts of *Hudsonia tomentosa* and *Cladonia rangiferina* are interspersed with *Geasta* and other *Cladonias*. Several other species of lichens and several woody toadstools are found on the stems of the dead clumps of *Prunus*.

In the quiet mud-bottomed pools a hundred yards back from the outer beach, which are flooded at high water by salt creeks, *Spartina polystachya* forms thick growths, along the edge of which grow *Salicornia*, *Buda marina* and several genera of *Schizophyceæ* with many green and red algæ.

Farther in from the Sound the shores of the Harbor are scattered with boulders on which are found many rock-bearing algæ. Among the *Chlorophyceæ*, e. g., *Bryopsis* and various species of *Cladophora* and *Enteromorpha* are found; while the *Phæophyceæ* are represented by such genera as *Ectocarpus*, *Sphacelaria*, *Punctaria*, *Chorda*, *Mesogloia*, *Fucus*, *Ascophyllum* and *Sargassum*; and such genera of the *Rhodophyceæ* as *Chantrelia*, *Nemalion*, *Ceramium*, *Callithamnion*, *Griffithsia*, *Polysiphonia* and *Chandriopsis* are abundant at or just below the lower sidemark. On the beach near these boulders several interesting fresh-water algæ are found growing in springs which flow from the top of a stratum of clay just at high-water level.

In the quiet brackish covers near the inner end of the harbor *Chondriopsis*, *Grinnellia*, *Dasya*, *Rhabdonia* and *Gracillaria*, with various species of *Ceranium* and *Polysiphonia*

are very abundant, as are also the species of *Monostroma*, *Ulva*, *Enteromorpha* and *Cladophora*.

In the ponds at the upper end of the valley occupied by the harbor, fresh-water algæ are present in great abundance and variety. Besides several unusual species of *Schizophyceæ*, such genera as *Pandorina*, *Volvox*, *Oedogonium* and *Bulbochete* are of frequent occurrence. In the springs and pools on the edges of these ponds an unusually large number of genera of desmids are present and *Batrachospermum* is occasionally found. Many interesting hydrophile phanerogams are also present in these ponds.

It is in the dense woods surrounding these ponds that we find the most interesting feature of the whole region. These woods are chiefly of oak, chestnut, beech and birch, with an undergrowth of *Clethra* and *Hamamelis* in the damper portions and of *Kalmia* in the drier ones. The damp soil and air make exceptionally favorable conditions for parasites and saprophytes. Such forms as *Cuscuta*, *Monatropa* and *Coralorhiza* are abundant, while the variety and abundance of the *Myxomycetes* and *Fungi* are quite remarkable. Fifteen genera of *Myxomycetes*, six of them new to the island, have already been noted and many new species of the more common genera will probably be found when the study of the region can be carried beyond the limited territory already visited. Among the *Fungi* the *Pyrenomycetes*, *Hysteriaceæ*, *Discomycetes* and *Helvellaceæ* of the *Ascomycetes*, and the *Hymenomycetes*, *Phalloideæ* and *Gasteromycetes* of the *Basidiomycetes*, are represented by large numbers of both individuals and species.

In conclusion a few words may be added concerning the value of the laboratory at Coldspring Harbor as a center for the study of localities other than that of the Harbor

itself. Long Island Sound is easily reached from the laboratory and excursions have been made on the launch of the laboratory to the rocky shores of Connecticut. A two hours' ride on the bicycle over good roads brings one to the Great South Bay, which contains certain oceanic animals not found at Coldspring, *e. g.*, *Cyanea*, *Aurelia* and *Zygodactyla*. This great bay is almost a new field for the biologist. The few attempts at dredging there, made during the past season, indicate that it will be a fruitful field for exploration. Finally, the eastern end of Long Island, with its extensive bays, can best be studied from the Coldspring Harbor laboratory as a base.

The general outlines of our fauna and flora are already sketched. This much knowledge is necessary as a basis for further work, whether in the way of instruction or in the way of research in anatomy, embryology or physiology, or in such systematic study as shall reveal more completely the kinds of organisms living here and the conditions which determine their occurrence.

CHAS. B. DAVENPORT.

COLDSRING HARBOR, August 8, 1898.

#### THE NERNST LAMP.

THE *Frankfurter Zeitung* contained recently a very interesting account of Professor Nernst's new electric lamp. As information on this subject has heretofore been so difficult to obtain, a brief abstract from this article may be of interest to the readers of SCIENCE.

As has been previously announced, Professor Nernst employs magnesium oxide for the illuminating material which at ordinary temperatures is a non-conductor, but when heated to a sufficiently high degree (and herein lies Professor Nernst's discovery) becomes a perfect conductor and emits a brilliant white light. The preliminary heating of the magnesia (A) Professor

Nernst accomplishes by placing it in the focus of a reflector (C) as seen in Fig. I. On the inner side of the reflector is a spiral wire of

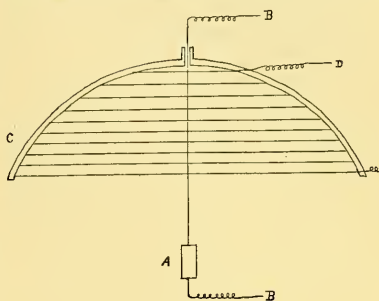

FIG. 1.

platinum (D) which, when brought to incandescence by a current, produces heat sufficient to render the magnesia a con-

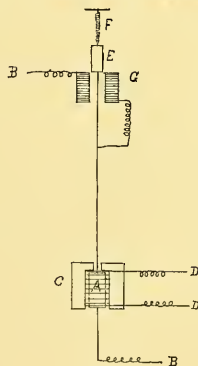

FIG. 2.

ductor; a current is then passed directly through the oxide by the wire (B) and that in the spiral is shut off. A complicated form of lamp is seen in Fig. II. Here the magnesia (A) is placed within a cylinder (C), which also incloses a platinum spiral (D). As soon as the incandescent spiral has heated the magnesia



sufficiently a current is passed through the oxide by the wire (*B*). Within this circuit is a coil (*G*) which upon becoming magnetic draws down the iron bar (*E*), thus lowering the now incandescent magnesia from within the cylinder. Upon breaking the circuit the coil loses its magnetism, and a spring (*F*) raises the iron bar and magnesia to their former positions.

As advantages over the ordinary incandescent lamps Professor Nernst claims that the same amount of light can be furnished at one-third the cost, and as the magnesia allows of being heated to a much higher degree than a carbon filament a purer light is obtained. The successful employment of a cheaper substitute for the platinum is also announced, though the name is not made public. In operating, either an alternating or direct current is used.

H. MONMOUTH SMITH.

HAMPDEN-SIDNEY, VA.

BOTANY AT THE ANNIVERSARY MEETING  
OF THE AMERICAN ASSOCIATION.

II.

*The Biology of Cheese Ripening.* PROFESSOR  
S. M. BABCOCK and DR. H. L. RUSSELL.

THE most important changes which occur during the ripening of cheese are those which affect the casein, this being gradually transformed, from the firm, elastic and insoluble conditions found in a green cheese, into the plastic and more or less soluble substance peculiar to a well-ripened product. The early explanations of these changes were purely chemical, but since the discoveries of Pasteur and others in the field of fermentation they have been attributed entirely to bacteria and other micro-organisms. Duclaux suggested that the changes in the casein were due to digesting organisms. Later observers have shown that such organisms fail to develop in competition with the lactic acid type of bacteria, which are by far the most promi-

nent species found in normal cheese. This type appears to be unable to digest casein to any considerable extent when grown in sterilized milk, unless their activity is greatly prolonged by neutralizing the acid as it is formed, in which case again the conditions do not conform to those found in normal cheese. Moreover, the ripening changes in cheese progress at a nearly uniform rate for a long time after bacterial development has greatly declined. The authors of this paper were unable to reconcile the many apparent discrepancies of the biological theory of cheese ripening until they attempted to sterilize milk for their experiments by the addition of mild antiseptics, such as ether and chloroform, which could afterwards be removed and thus avoid changes which might be produced by boiling the milk. Such milks, although sterile, passed through changes similar to those that occur in cheese. As the agents used in this case discriminate between organized and unorganized ferments, it is evident that milk contains an unorganized ferment capable of digesting casein. This enzyme is inherent in the milk itself. The authors have given to this ferment the name *galactase*, and they believe it plays an important rôle in the proteolytic changes that occur in the ripening of cheese.

*Fermentation without Live Yeast Cells.*

KATHERINE E. GOLDEN and CARLETON G.  
FERRIS.

THIS paper first summarizes the rather extensive and contradictory literature, beginning with E. Büchner in 1897, who claims to have induced active fermentation of various sugars with a sterile extract obtained from dried yeast by filtration through a Berkefeld filter. Büchner's method was followed in the preparation of the yeast. In filtering, the fluid was first passed twice through three thicknesses of

filter paper, and then through two thicknesses of parchment paper. The filtered fluid appeared clear and opalescent, but on microscopic examination live cells were found. A filter was then made by putting two thicknesses of filter paper in a glass funnel and coating with about  $\frac{1}{2}$  inch of gypsum. The funnel was then fitted into a flask and the whole sterilized. The filtrate from this was clear, but also contained a few live cells. The filtrate remained clear for three days and then became clouded from growth of yeast and bacteria. The same results were obtained from a gypsum filter an inch thick. A porous cup was then used with an aspirator to hasten filtering. Using this filter a sterile extract was obtained. This was tested in 10 and 20 % cane sugar, dextrose and wort solutions, but no fermentation took place in any of them. The experiment was repeated three times and at 37.5°C. as well as at room temperatures, with negative results in every case. The experiments were then repeated with another compressed yeast which also gives vigorous fermentation, but with negative results in every case. Inasmuch as Büchner now states that only certain yeasts possess this property, it is desirable that he should name and describe the yeast or yeasts which he used.

#### *Deterrent Action of Salt in Yeast Fermentation.*

KATHERINE E. GOLDEN.

THESE experiments show that sodium chloride in any but minute quantities retards fermentation and indicate that where a sponge is used, and a quick fermentation desired, the salt should be added in the last stages. Experiments were made on sponges and stiff doughs at three temperatures, 23°, 37° and 40°C. The following table shows the increments of fermentation in inches, by half hours, in long test-tubes, the temperature being negligible:

No. of Exper.	Per cent. of salt added.	Increments of fermentation in inches.			
		$\frac{1}{2}$ hour.	1 hour.	1½ hours.	2 hours.
a	0	.666	1.375	1.708	1.583
b	1	.542	1.292	1.625	1.625
c	2	.456	1.200	1.500	1.666
d	3	.354	.958	1.375	1.375
e	4	.313	.875	1.250	1.375
f	5	.146	.292	.438	1.666

Experiments in fermentation tubes, using 25 cc. volumes of Pasteur's solution with cane sugar, and equal quantities of yeast (1 gram of dry yeast cake) and varying quantities of salt, gave the following results: In the control tube the fluid was driven from the closed end in 23 hours; with 4% salt the fluid was driven out in 37 hours; with 8% salt, in 38 hours; with 12% salt, in 47 hours; with 16% salt, in 7 days.

#### *Leaves of Red Astrachan Apple immune from the Attack of Gymnosporangium Macropus.*

PROFESSOR W. J. BEAL.

RECORDS failure of disease to spread from infested cedar trees to two young Astrachan apple trees, purposely planted near, and also negative result of several inoculation experiments, all made in 1897. In 1898 experiments were repeated with same result. States that Professor L. R. Jones, of Vermont, has had the same experience.

#### *Notes on Stewart's Sweet Corn Germ, Pseudomonas Stewarti n. sp.* DR. ERWIN F. SMITH.

ABSTRACT omitted on account of its length. See Proceedings of the Association; also a reprint from the same.

#### *A Bacteriological Study of Pear Blight.* LILLIAN SNYDER.

THE greater part of this paper describes a non-parasitic organism which was found associated with *Bacillus amylovorus* in blighting trees. This organism is white and on solid media its colonies closely resemble those of pear blight. It also resembles the latter morphologically. Both germs grew

slowly in corustarch cooked in water, and sugar was not formed. Both change cellulose to sugar and the non-parasitic one gives a slow fermentation when the cellulose is made up with peptone. In pure moistened cellulose the growth of both was very slow and sugar was not formed in either case. Both prefer high temperatures. It differs from the pear blight germ in the following ways: Feeble growth in healthy tissues and no symptoms of blight (young twigs and unripe fruits of the pear and quince). In unripe fruits it was alive at the end of ten days and in some cases had extended to the opposite side of the fruit and into the seeds. Mixed in water in equal parts with the pear blight germ and inoculated into twigs, blight ensued, but when the tissues were examined, at the end of ten days, only *B. amylovorus* was found, although several attempts were made to isolate the other germ.

Unlike pear blight, it ferments potato broth, pear broth and cane-sugar solution, with a copious evolution of gas. A large fermentation tube of Smith's solution yielded about 200 cc. of gas in 10 days. This consisted of 6.2% nitrogen, 61% carbon dioxide and 32.8% hydrogen. The growth in broth made by cooking unripe pears in water was slower than that of *B. amylovorus* and in 48 hours the fluid became a deep green. In peach broth made in the same way the same deep green color appeared and zoogloæ were quite abundant. The writer has not been able to discover zoogloæ in cultures of the true blight bacillus. In potato broth this germ grew much more rapidly than *B. amylovorus* and gas production began in a few hours.

This organism is best obtained by placing pieces of tissue in bouillon. The same or a similar germ was also obtained by washing the surface of healthy twigs into bouillon or Smith's solution. One which turned pear broth green was also obtained from the surface of grains, especially wheat. By

means of platinum needle transfers from the interior of freshly blighted twigs the true bacillus of the blight may be separated with less danger of contamination. The fact that this germ does not apparently injure the trees when inoculated into them, also that it is obtained by washing the surface of healthy twigs, proves that it has no essential connection with the disease, and renders it probable that it is a surface germ. This work was carried on in the laboratory of Dr. J. C. Arthur, at Purdue University.

*Life History and Characteristics of the Pear-Blight Bacillus.* MERTON B. WAITE.

BEGINNING in the spring, the germs on the new growth first appear on the nectar disks of the blossoms. The bacilli live and multiply in the nectar and are able to enter the nectar glands without a puncture or injury, and thus normally get inside their host. The distribution from flower to flower and tree to tree is through the agency of insects, mainly flower-visiting sorts. Infection also occurs on the young shoots, and less frequently on the fleshy bark through injuries. Insects and birds are agents of distribution and inoculation in these cases. No evidence has been found that the germs are carried by the wind. The organism usually dies out in the twigs which are blighted and dead, but in certain cases the germs manage to keep alive during the summer by making slow progress in the fleshy living bark. Such cases may succeed in living over winter. Winter weather is favorable to the longevity of the organism, on account of the moisture and low temperature. These cases of 'hold over blight' start off again in spring and exude quantities of gummy matter full of the bacilli. This is visited by insects, especially flies and wasps, and is carried on to the newly opened flowers, thus completing the cycle of the year. In brief, the characters of the germ are as follows: An



oval, rod-like bacillus, 0.6 to 0.8 by 1 to 6  $\mu$ , constant in diameter, but varying greatly in length. Occurs singly, or in young cultures in pairs, chains or masses. Stains readily with the ordinary aniline dyes, either in water or alcoholic solution. Has no capsule, but is supplied with several flagella scattered over the surface and is actively motile. Does not produce spores. On nutrient beef and potato broth produces first a strong turbidity and a slight granular pellicle, which breaks up and settles to the bottom. The color of the mass is milky white on all solid media. On agar plates the surface colonies at ordinary temperatures (18° to 20° C.) reach a diameter of about 1 mm. in 48 hours and at the end of a week become 5 to 6 mm. across. A temperature of 36° to 37° C. starts the growth more promptly, but results in a feebler ultimate development. The addition of malic or citric acid in small amounts so as to feebly acidify the agar increases the vigor of growth, while an excess of alkali diminishes it. On gelatine made from the common brands the opposite effect is produced. Gelatine should be neutral to phenolphthalein to insure vigorous development. There is a moderate liquefaction in good gelatine cultures. A moderate growth is made on sterile cooked potato cylinders. In the fermentation tube it decomposes sugar without the formation of gas. It is most vigorous with maltose, the cultures becoming strongly acid, and is slightly less so with cane sugar, dextrose and laevulose. It is aerobic and facultative anaerobic. It produces no pigment or coloring matter of any sort, and no odor. It does not decompose starch. Its principal food consists of nitrogenous matter, sugars and probably to some extent certain organic acids—to wit, the substances found in young growing tissues of its host. Certain statements formerly made are known to be erroneous. The germ mass was said to be yellowish-

white on potato. This could only come from an impure culture, as the true pear-blight germ is always white. Gas, or in some places carbon dioxide gas, is said to be formed. This never occurs. Butyric acid is said to be one of the products of its decomposition. The germ produces acids, but never butyric. Starch is said to be decomposed and used as food, but, so far, the author has not been able to demonstrate this. The germ is said to live over winter in the soil. The author has failed to find it in the earth, and its life cycle is complete without such hypothesis.

*On the Occurrence of a Yeast Form in the Life Cycle of Spheropsis malorum.* PROFESSOR WM. B. ALWOOD.

PAPER records the discovery of a yeast form in laboratory cultures of this fungus. On isolation and inoculation on the fruit of the apple the common fruit bodies characteristic of *S. malorum* made their appearance.

*Some Steps in the Life History of Asters.* PROFESSOR EDWARD S. BURGESS.

THIS paper presents results of field-studies of *Aster* variations made during the last twelve years. Its purpose is to review certain known terms in the ontogeny of *Asters* which are liable to misinterpretation. These sources of confusion are of three classes, the first of which is the number of leaf-forms normally developed at once upon a single stem. There are eight principal forms:

- a. Primordial leaf, usually roundish and transient.
- b. Radical leaves, two or three or more, often progressively different.
- c. Lower cauline leaves, usually the most characteristic.
- d. Middle cauline leaves, usually transitional in shape.
- e. Upper cauline leaves, usually much smaller.

f. Axile leaves, subtending the primary axils.

g. Rameal leaves, on primary branches.

h. Bractlets, on the ultimate branches.

According as one or the other of the parts of this leaf-series is more strongly developed, or is suppressed, the plant will change aspect and may be mistaken for a new species. The other two sources of confusion now to be considered are the normal and the accidental, or less usual successive terms in the life-history of the species. These are here treated together, distinguished by number and letter, the normal or usual by the letter *N*, the accidental or less usual by the letter *A*.

*N*<sup>1</sup> Seedling stage, usually with two small radical leaves.

*N*<sup>2</sup> Radical-tuft stage, often conspicuous, often remaining some years before developing into *N*<sup>3</sup>.

*A*<sup>1</sup> Oval-topped stage, frequent in Biotian Asters, the normal cordate radical tuft becoming topped out with the smaller, thinner, oval or other non-cordate leaves.

*A*<sup>2</sup> Plantain-leaf stage, an occasional extreme development from the last, the non-cordate leaves becoming the predominant ones, and often resembling *Plantago major* in size and shape.

*N*<sup>3</sup> Cauline stage, normally following *N*<sup>2</sup>, the radical tuft sending up an erect leafy stem which bears six of the eight leaf-forms already mentioned. But instead of taking this normal course of development, the plant may enter upon any one of the following seven stages which are enumerated as accidental or less usual.

*A*<sup>3</sup> Intercalary stage, when one or more little leaves are interpolated into the series with much larger leaves above and below.

*A*<sup>4</sup> Arrested stage, when the gradually diminishing normal series of cauline leaves meets sudden arrest from which it never recovers, a succession of little leaves now continuing into the inflorescence.

*A*<sup>5</sup> Sprout form, usually with leaves somewhat different in form and size from the type.

*A*<sup>6</sup> Ramified or branch-leaf form, when, after suppression of the main stem, one or more branches rise to replace it, with new direction, and the leaves larger and more numerous, but the leaf-form remaining true to the branch-leaf type for that particular species.

*A*<sup>7</sup> Bifurcation, either in leaf or stem, arising apparently not from accident, but as a sport.

*A*<sup>8</sup> Opposite leaf state, due to suppression of internodes, especially upon abnormal branches.

*A*<sup>9</sup> Verticil form, three nodes brought together in inflorescence or rarely in the leafy stem.

*N*<sup>4</sup> Aestivation, the budding stage; often a very different aspect is taken here from that before or after.

*N*<sup>5</sup> Flowering stage, beginning with erect terete rays, which are soon tubular by involution, and in anthesis may change greatly, according as the following progressions become developed or not:

a. Pedicels lengthen, changing sessile buds into long-pedicelled flower-heads, and dense branches into loose clusters.

b. Cymose development may prolong the outer branches so as to overtop the central and original inflorescence.

c. Rays flatten across, becoming flat and rounded.

d. Rays change position from erect to horizontal, and finally recurved, incurved or pendulous.

e. Rays change color with age to white, greenish or brownish.

f. Disks change color early from yellow to red, reddish-brown or brownish.

g. Disks change from flat to dome-shaped.

h. Pappus changes color by yellowing, darkening or reddening.

*A*<sup>10</sup> Enfeebled state, after close cutting

down; when the new stems rising from the same root-stocks the next year are often shorter, weaker, scantier and paler in inflorescence and less varied in leaf.

$N^6$  Resting stage, when, instead of the preceding ( $N^5$ ) or after it, the root-stock develops radical leaves only for a series of years.

$N^7$  Surculus stage, a lateral offshoot, arising from the preceding root-stock, rising and making ready to enter upon the radical-tuft stage,  $N^2$ , and renew the round of the life-history.

Specific distinctions are hardly to be found in the constant absence or presence of any of the less usual stages, but rather in the relation the plant bears to them when they are found, the ease with which they are induced or thrown off, and the shapes assumed when induced. Some species habitually elide one or more terms in the series, some accelerate them, some prolong or accentuate them. An exceptional development does not invalidate a specific character, as its possibility is latent in all.

*The Embryology of Taxus.* E. J. DURAND.

In this paper the development of the female prothallium is traced from one of an initial axial row of about three cells. The nuclei which result from the division of the nucleus of the macrospore arrange themselves in a peripheral layer, and walls are formed between them so that the young prothallium is in the form of a hollow sphere, the center of which gradually becomes solid from the ingrowth of the cells. The archegonia are developed at the distal end of the prothallium. The neck of the archegonium consists of four cells, instead of one, as is usually stated for this plant.

*Effect of Fertilizers on the Germination of Seeds.*

GILBERT H. HICKS.

THE tests were made with the seeds of wheat, lettuce, radish and crimson clover. The conclusions reached are as follows:

1. One per cent. strengths of muriate of potash and of sodium nitrate are very detrimental to seeds, whether applied directly or mixed with the soil.

2. Fertilizers composed of phosphoric acid or of lime are much less injurious to germination, and if not used in excess may be harmless.

3. Commercial fertilizers should not be brought into direct contact with germinating seeds.

4. The effect of treating seeds with chemicals before planting is no index to the action of those chemicals when applied as manures to the soil.

5. The chief injury from chemical fertilizers is effected upon the young sprouts after they leave the seed coat and before they emerge from the soil, while the seeds themselves are injured only slightly or not at all.

6. It is highly improbable that potash, phosphoric acid, nitrogen or lime used as fertilizers actually favor germination.

*The Pleistocene and Plant Distribution in Iowa.*

DR. T. H. MACBRIDE.

THIS paper offers a new explanation for certain peculiarities of distribution characterizing the flora of that prairie State. It appears that certain plants, especially northern species, are not only very rare in Iowa, but are in their distribution limited to very small and far-separated areas. No existing conditions seem to offer any explanation. Recent study of the pleistocene geology of the State brings to light, however, the fact that these isolated stations for Iowa's rarer plants are all of them *driftless* areas, *i. e.*, areas entirely exempt from glacial deposits. So remarkable is the coincidence that we may confidently say that wherever the geologist finds a driftless hill-top there certain plants are sure to occur and *vice versa*. The paper was illustrated by a map.



*Observations on some Hybrids between Drosera intermedia and Drosera filiformis.* PROFESSOR JOHN M. MACFARLANE.

THE author reported the discovery and described the appearance of a number of *Droseras* which are morphologically intermediate between the species named, in number and position of the flowers, number and shape of the leaves, scales, etc., so that he thinks there can be no reasonable doubt as to the occurrence of hybrids between these two species. Drawings were exhibited and explained.

*On the Validity of the Genera Senna and Chamæcrista.* CHARLES L. POLLARD.

A RECORD of further observations on the structure of the flower of *Cassia Chamæcrista*, on the floral arrangement of which Professor E. L. Greene commented in a recent issue of *Pittonia*. He found that the corolla exhibits a torsion of 90° to the left and thereby differs materially from that of *Cassia* proper. Other characters were adduced to prove the distinctness of the two genera.

*Species Characters among the Violets.* CHARLES L. POLLARD.

*Development of the Pollen Grain in Symplocarpus and Peltandra.* B. M. DUGGAR.

DIVISION of the primitive archesporium is of the vegetative type, and the number of chromosomes present is that of the whole number of the sporophyte. The resting nucleus of the definitive archesporium has a large nucleolus taking the chromatin stain in the Flemming combination. The reticulum is a loose net very slightly chromatic. In the cytoplasm there is no differentiated zone of kinoplasm. The contracted state of the chromatin thread in the late reticulum or early spirem was found abundantly at a definite period in the life-history of these cells prior to actual division. In this condition staining is difficult, and the return from this phase is characterized especially by a loosening of the ribbon in one

perfect coil, thus truly imitating the spirem. The spirem ribbon becomes nodulate, and finally segmentation is preceded by a bending back of the ribbon at definite points and the disappearance of the chromatin along the connecting linin. The formation of the spindle is multipolar and the chromosomes are centrally as well as peripherally arranged. The nucleolus is peculiar in assuming various shapes and in showing linin connections with the general ribbon. The first division, in general, indicates that there is a longitudinal division of the chromosomes, although in *Symplocarpus* there is a suggestion that the first division may be the reducing division and hence transverse. In the second division the daughter segments separate longitudinally in both cases. There is no return of the nucleolus prior to the second division, but a true dispirem is formed. This is in accord with studies on *Liliaceæ*, but differs from what is found in some dicotyledonous plants. In the division of the microspore nucleus the nucleus migrates to one side of the cell and the entering kinoplasm forms a multipolar somewhat barrel-shaped spindle. This finally becomes completely attached at one pole, forming a truncated cone, while the other pole of the spindle may be truly conical. This fixity of the spindle causes the unequal division of the cell body, necessitating the small generative cell. This method of division (fixity of one pole) seems to be characteristic of such divisions in many plants.

*Notes on the Embryo-sacs of Certain Monocotyledons.* K. M. WIEGAND.

RECENT investigations by Dr. Wiegand tend to show that the two extreme types of embryo-sac formations as illustrated by *Lilium* and *Canna* are related in a manner not before observed. In *Convallaria*, which represents the transitional type, a septum is formed after the first division of the hypodermal nucleus, but not after the second.

This represents an axial row of four cells with two septa omitted. The remaining septum at length breaks down, so that a single cavity containing eight nuclei results. The single cell of *Lilium* is, therefore, derived from the four axial cells of *Canna*, not primarily through the omission of any divisions of the mother cell, but by the absence of the septa.

*Studies Relative to the Perigynium of the Genus Carex.* K. M. WIEGAND.

THREE theories have been advanced as to the homology of the perigynium in the genus *Carex*. By Bentham and others it was considered to be composed of two united bracts. Schleiden considered it to be a modified perianth; but the most plausible theory is that advanced by Pax, Dyer and Kunth, who emphasize the fact of its close resemblance to the prophyllum of other monocotyledons. In many cases the secondary axis within the perigynium develops to such an extent that several rudimentary flowers are formed in addition to the fertile one. The perigynium is, therefore, not a perianth. The position of the odd carpel, which is turned toward the main axis of the spike, and the development of the perigynium from two posterior teeth, seem to indicate that the perigynium is, indeed, a modified prophyllum.

*Rapidity of Circumnutation Movements in Relation to Temperature.* E. SIMONS and R. E. B. MCKENNEY.

FIVE species were experimented with, viz.: *Phaseolus vulgaris*, *Humulus lupulus*, *Convolvulus sepium*, *Lonicera brachypoda* and *Wistaria sinensis*. Darwin also experimented on these plants, but gives few exact details as to temperature. The average there in England is 15° or 16° C. in spring and 20° to 23° C. in summer. In this paper no account is taken of the relative intensity of the light, although data are being gathered which prove that this is an extremely im-

portant factor. In dull cold days, with temperature at 15° to 19° C. movements were found to be *extremely* slow. The average optimum for best results was 28° C. In *Convolvulus sepium* two distinct types of stem were observed, a rapidly circumnating and a prostrate one showing extremely feeble movements. In the results obtained by the writers it is safe to assume that the temperature was on the average 12° C. higher than that worked in by Darwin, and in most cases the periods of revolution are very considerably shorter, but at present it would be rash to say that the higher temperature is the sole or even the main determining factor in the more rapid movement. Light intensity and hygrometric conditions of the atmosphere have been found to cooperate also, but present indications are that temperature is a very important factor, and that an optimum as well as a maximum and minimum temperature exist for each species.

*General Characteristics of the Duneflora of Southeastern Virginia.* THOMAS H. KEARNEY, JR.

REPORT of a preliminary survey of the plants of the coastal plain with reference to their ecological distribution. The soils, heat, light and other physical conditions were first described. The principal plant groups were thus described with an enumeration of some of the more evident adaptations by which the plants were brought into harmony with the physical conditions.

*Vegetation of the Wooded Fresh-water Swamps of Southeastern Virginia.* THOMAS H. KEARNEY, JR. (Read by title.)

*Notes on Arctic Willows.* PROFESSOR W. W. ROWLEE.

THE Cornell party on the Peary expedition of 1896 brought back an exceptionally good collection of willows on which this paper is based. The glaucoid and myrtilloid

groups, which are perhaps the most difficult to segregate, have several interesting forms. This paper attempts to characterize the forms of *Salix glauca* L. and *S. greenlandica*.

*A Self-registering Transpiration Machine.* EDWIN B. COPELAND.

DESCRIPTION of a very simple and easily operated apparatus, consisting of a wheel over which runs a string carrying the plant tested on one end and an areometer on the other. As the plant loses weight, the counter weight, the areometer sinks. The record is kept as with an auxanometer. One day's record was presented to illustrate the working of the machine. To be published in *The Botanical Gazette*.

*Methods of Studying the Sap Pressure of the Sugar Maple.* PROFESSOR L. R. JONES.

AFTER some unsatisfactory experiments with the common mercurial gauge, a self-recording steam-pressure gauge (which was exhibited) was substituted with very good results. Lithium passed upward and downward in the maples very rapidly, but there was very little sidewise movement of this substance.

*Notes on the Physiology of the Sporophyte of Funaria and Mnium.* DR. RODNEY H. TRUE.

THE growth rate of the sporophyte of these mosses may be represented by a rather flat curve rising somewhat more gradually than it falls. Subsequent to the breaking loose of the calyptra from the gametophyte, growth is confined to the distal end of the sporophyte, and the growing region, about 2 mm. long, is entirely enclosed by the calyptra.

The calyptra, much developed in *Funaria*, less so in *Mnium*, is a protective structure chiefly useful in preventing desiccation. In *Funaria* the cells of the calyptra are living and contain chlorophyll grains. They are

probably self-supporting as regards nutrition until the rupture of the calyptra.

The curvature of the seta in this species results as a response to the stimulus of gravitation. In the earlier stages of its growth the seta is not sensible to this stimulus, but becomes so as the time for the development of the capsule approaches, and by use of the mechanism of growth executes the curvature.

The direction of the strongest illumination determines the radius in which the capsule shall fall. In *Mnium* the capsule falls with great regularity away from the direction of the strongest illumination, thus exposing the end of the capsule bearing the stomata to the light. Occasionally some fall directly toward the strongest light, but very rarely out of that plane.

*Funaria* obeys, with much less precision and regularity, the same rule. The conduct of these mosses varies in accordance with the nature of the situations which they are wont to occupy.

*The Seeds and Seedlings of some Amentiferae.*

W. W. ROWLEE and GEO. T. HASTINGS.

As compared with the other groups of angiosperms the Amentiferae have been, so far as their seeds and seedlings are concerned, very indifferently observed. Finding this to be true led the authors of this paper to grow seedlings of the native representatives of the group. Their studies have led to the following conclusions: 1. The cotyledons in *Juglans* and *Hicoria* correspond with the valves of the nut, and are deeply two lobed. The two divisions of the embryo resembling cotyledons are each made up of halves of the cotyledons. 2. The seeds of *Hicoria* germinate without frost action; those of *Juglans* only with frost action. 3. The tap-root is very thick in young seedlings, and very long in older ones. 4. In *Castanea* and *Quercus* the shell is split by a swelling of the coty-



ledons in germination. 5. In the species of *Quercus* studied, the leaves of the seedlings were much alike, and not deeply cut or lobed. 6. *Fagus* is the only genus in which the hypocotyl lengthens, or the cotyledons become aerial.

The paper was illustrated by two plates; one showing the peculiar division of the cotyledons in *Juglans* and *Hicoria*, the other various seedlings of the group.

*The Morphology and Taxonomic Value of the Fruits of Grasses.* P. BEVERIDGE KENNEDY.

THE presence of an epiblast and a plumule sheath distinguishes the embryo of the Gramineæ from that of other monocotyledons. About eighty genera were investigated to determine the constancy, morphological significance and taxonomic value of these peculiar organs. In general, species of the tribes Maydeæ, Andropogoneæ, Zoysiæ and Tristeginæ are without epiblasts, while those of the tribes Oryzæ, Agrostideæ, Aveneæ, Chlorideæ, Phalarideæ, Festuceæ, and perhaps the Bambuseæ possess epiblasts. Peculiar exceptions occur in some tribes, *e. g.*, the Hordeæ appears to have equally as many with as without epiblasts. From study of the perfectly developed epiblasts in *Zizania*, *Leersia* and *Oryza* the author is led to believe that the epiblast is a second rudimentary cotyledon opposite to the scutellum (cotyledon). The plumule sheath is constant in all embryos, and from his study of the vascular system, together with Hanstein's investigations on the development of the embryo of Brachypodium, the author believes that it is a ligule-like growth belonging to the scutellum and is homologous with the ligule of the fully developed grass leaf. Unlike Bentham and Haeckel, he is inclined to believe that the Bambuseæ and Oryzæ together represent the most primitive grasses. The Oryzæ resemble the Bambuseæ as follows:

1. They show great variation in the structure of their fruit and spikelet.
2. They possess remarkably large epiblasts.
3. Some have the same number of lodicules.
4. *Pharus* has a style with three stigmas.
5. Many of the genera have broad petiolate leaves and transitions between these into linear leaves.
6. To a great extent they have the same geographical distribution, the larger number of the genera being indigenous to tropical America. According to Haeckel's classification, the tribes Zoysiæ, Tristeginæ, Andropogoneæ, Maydeæ and Paniceæ, both according to the characters of the fruit and those of the inflorescence, form another natural group joined to the Oryzæ through Zoysiæ and Tristeginæ. The Chlorideæ, although regarded by Haeckel and Warming as being removed some distance from the Andropogoneæ, have been found like them in their fruit characters. Judging from their fruit characters, the remaining tribes, Phalarideæ, Agrostideæ, Aveneæ, Festuceæ and Hordeæ form another natural group in the order named, and this coincides with the classification given by Haeckel.

To avoid a session Thursday evening, the following papers were read by title:

*The Caryopsis of the Gramineæ.* PROFESSOR L. H. PAMMEL.

*The Ecological Distribution of Colorado and Wyoming Plants.* PROFESSOR L. H. PAMMEL.

*Fertilization of the Muskmelon Flower.* PROFESSOR WM. F. RANE.

*Notes on Destroying Comptonia asplenifolia.* PROFESSOR WM. F. RANE.

*Length of Time from Blossoming to Seed Development in Leucanthemum vulgare.* PROFESSOR WM. F. RANE.

*The Work Performed by the Agricultural College toward a Botanical Survey of Michigan.* PROFESSOR W. J. BEAL.

SEVEN additional titles appeared on the

preliminary program, but were omitted from the regular program because no abstracts were furnished.

ERWIN F. SMITH,  
*Secretary.*

*SURVEYS OF THE GATEWAYS TO ALASKA.*

A BEGINNING has at last been made in the accurate mapping of the delta of the Yukon, one of the great rivers of the world. Through the courtesy of Superintendent Pritchett we are enabled to give a preliminary account of the work done in that locality during this year and to advert to further operations of the Coast Survey at the head of Lynn Canal, another of the gateways to the interior of Alaska and the British Yukon district.

On June 30th the U. S. Coast and Geodetic Survey party arrived in St. Michael, Alaska, and immediately began preparations for the survey of that part of the delta of the Yukon River bordering on the seacoast.

The prime object of this expedition was to examine the delta of the Yukon River with the purpose of finding out what depth of water exists on the bars in front of the delta and to locate such channels as were found flowing from the mouths of the river into Bering Sea. This problem necessitated the execution of a scheme of triangulation upon which to base the required topography and hydrography.

While the two small steamers required for hydrographic work off the delta were being fitted out by a section of the party at St. Michael the other members were engaged in triangulating and mapping the coast from St. Michael southward to the Aphoon (pronounce Ap-hoon) mouth of the Yukon, and in making a detailed survey of the towns of St. Michael, Healy and immediate vicinity. This detail map proved of much value to the military authorities of St. Michael Military Reserva-

tion in settling the matter of boundary lines between the commercial companies located there.

The channel and bar of the Aphoon mouth of the Yukon River were surveyed and developed. This is the channel that has always been used by steamboats for getting into the river from St. Michael.

While this work at the Aphoon mouth was in progress another small party had gone on one of the small steamers to the Kusilvak mouth of the river, establishing a latitude and longitude station well inside of the coast line. From this station it proceeded seaward with a topographic and hydrographic survey.

From all reports of the natives and others it seems reasonably certain that the Kusilvak mouth is the deepest of the mouths of the river, and this survey shows that it has much the greatest volume of water.

From the latter part of August to the end of the season the whole party was at work on the Kusilvak mouth of the river and southward along the coast, including and beyond the mouth of the Krypniak River. The Kusilvak mouth was found to be about twenty-five miles farther northwest than given on the most recent charts. All that can now be said of this mouth of the river is that eight feet of water can be carried into it at low tide, whereas there is only two feet at low tide on the bar at the entrance to the Aphoon mouth, the one now used by steamboats plying on the Yukon River.

From the investigations made of the Kusilvak mouth the shallowest water on the bar is from three to six miles off shore and the eight-foot channel is very crooked and difficult to follow with a vessel. It cannot be followed at all except by the constant use of a sounding lead. The use of buoys appears impracticable on account of the outflow of ice each year, which would not only carry the buoys away, but no

doubt change the channel itself in places. It appears that no feasible channel exists in the Kusilvak mouth for vessels of over ten feet draught.

Magnetic and gravity determinations were also made by the party while at St. Michael. The party left the Yukon delta and returned to St. Michael on September 13th, in order to haul out the vessels before the freezing up of the river, which occurs some time in the latter part of September.

The astronomical observations were obtained only after long waiting because of the continued cloudy weather, while the frequent storms of wind and rain interfered much with the other work in hand.

The hundreds of square miles of mud lying between high and low water of the delta, which was found navigable for neither boats nor boots, presented a problem not usually encountered in surveying. After the low grass flat which lies above the ordinary high water of the delta was finally reached, the surveyors were greeted by myriads of mosquitoes, whose vexatious assaults are the crowning difficulty to be encountered in charting the Alaskan coasts.

Another Coast Survey party charged with the topographic reconnaissance of the headwaters and passes of the Lynn Canal, Alaska, arrived at Haines' Mission on May 7th, where the party separated, one part going up the Chilkat River and the other taking up the work in the Khatschin Valley. Each party was composed of a chief and five men.

The rivers forming the head waters of Lynn Canal have very swift currents and they were ascended under great difficulty and with much loss of time, as the loaded boats had to be tracked the entire distance, the men generally wading in the ice-cold water, overhanging alders precluding shore-tracking, excepting such stretches where gravel and sand-bars are deposited along the river shores. The water level fluctuates

with the weather, rising rapidly after a day or two of clear weather, when the snow and ice of the adjoining mountains undergo a rapid melting. The main channels of these rivers change with every freshet, new bars being formed while old ones are washed away. This fact, together with numerous snags scattered about between islands and on sand bars, makes navigation, even with small boats, difficult and risky. The Khatschin party, while descending that river in June, lost one boat and a part of the outfit and records by being wrecked on a snag, the men barely escaping with their lives.

The parties suffered little from rainy weather, but the fogs and mists rarely left the higher altitudes for more than a day at a time, hiding from view the mountains which were to be located cartographically. Owing to the small number of clear days that are generally met with in the mountains of this region, it had been decided to use the photo-topographic surveying method, as it had given good results for the topographic reconnaissance of south-eastern Alaska made under the direction of the Alaskan Boundary Commission.

Both parties were supplied with plane-tables for mapping the valleys and photo-topographic outfits. They have returned with instrumental and photographic records, which, when mapped, will cover an area of about 500 square miles, distributed over the valleys of the Chilkat, Tsieku, Tlahini, Khatschin, Skagway and Dyea Rivers, including the tributaries near their heads.

---

#### NOTES ON INORGANIC CHEMISTRY.

THE *Chemical News* contains a paper by Robert Meldrum on the action of water and saline solutions on metallic iron. In each experiment six feet of piano wire were exposed in the solutions in a four-ounce bottle. In many of the experiments with



distilled water the water was sterilized, and the author concludes that the oxidation of iron takes place in water in the absence of bacteria and other forms of life, and of ammonia and carbon dioxide. As in no case was air vigorously excluded, the author concludes that it is as yet an open question whether it is the water or the dissolved oxygen which acts upon the metal. In the second series saline solutions were used, alkalies and alkaline salts being experimented with. In general the alkalies prevented action on the iron, but many alkaline salts, as potassium carbonate, hydrogen sodium phosphate, sodium meta- and pyrophosphates and the bicarbonates, do not prevent action. Sodium peroxide had no effect. Alkaline potassium salts act more strongly on iron than the corresponding sodium compounds.

In a recent letter to *Nature*, Sir William Crookes corroborates the observations of Friedlander and Kayser and of Baly, that helium is a constituent of the atmosphere. In examining the more volatile positions from liquid air no difficulty was found in observing the lines of helium. A sample of helium separated by Professor Dewar from Bath gas showed the undoubted presence of neon. The presence of helium in the atmosphere is at variance with the theory advanced, that owing to its great molecular velocity any helium in the atmosphere would escape from the influence of gravitation, unless, indeed, helium is present in space.

J. L. H.

#### BOTANICAL NOTES.

##### THE FLORA OF THE UPPER SUSQUEHANNA.

MR. WILLARD N. CLUTE has been studying the flowering plants and ferns of the region drained by the upper Susquehanna and its tributaries, mainly in southern New York, with a small area in northern Pennsylvania, and has brought out his results in

the form of a pretty little book of about 170 duodecimo pages. He has not attempted to make a phytogeography of the region, but has given us a local list, which the phytogeographer may profitably take, with similar lists of other regions, in attempting to present a general view of our flora. The book opens with a short introduction, in which there is a little about the topography, geology, rivers and streams, lakes and ponds, bogs and swamps, mountains and ravines, elevations, temperature, rainfall, etc., with brief observations upon the characteristics of the flora, the lesser floras, statistics, etc. No less than 1105 species are catalogued, a very good showing when it is remembered that only Spermatophytes and Pteridophytes are included.

The nomenclature is quite appropriately the modern one, in accordance with the much discussed 'Rochester Rules,' and the families appear to agree with those of Engler and Prantl's *Pflanzenfamilien*, but their sequence is that of the Sixth Edition of Gray's Manual, even to the position of the Gymnosperms, between the Dicotyledons and Monocotyledons. The record of localities given with the species will be of much service to the phytogeographer, for which purpose the citations should have been still more explicit in many cases. The rarer plants fare better in this regard than do those which have a rather wide distribution.

##### BOMBAY GRASSES.

THERE has recently appeared from the government printing press of Bombay, India, an important work on the grasses of the Bombay Presidency, from the hand of the lamented Dr. J. C. Lisboa. The region covered extends along the Arabian Sea, from  $14\frac{1}{2}$  to 28 degrees of north latitude, or about one thousand miles, and from the coast to an irregular interior line distant from one to three hundred miles, and includes nearly two hundred thousand

square miles of territory. From its latitude the region is seen at once to be distinctly tropical. On our own continent its position is equivalent to the region stretching from northern Nicaragua to southern Texas. In this region Dr. Lisboa found 278 species of grasses, a very good number when we consider that this is a list made in India, and a preliminary list at that.

The general nature of this grass flora may be seen from the following synopsis of the tribes :

<i>Panicææ</i> ,	13 genera,	71 species.
<i>Tristegineæ</i> ,	1 genus,	13 "
<i>Oryzææ</i> ,	2 genera,	2 "
<i>Zoysieæ</i> ,	5 "	5 "
<i>Andropogoneæ</i> ,	21 "	109 "
<i>Maydeæ</i> ,	3 "	4 "
<i>Agrostideæ</i> ,	6 "	14 "
<i>Aveneæ</i> ,	4 "	5 "
<i>Chlorideæ</i> ,	8 "	22 "
<i>Festuceæ</i> ,	8 "	25 "
<i>Hordeæ</i> ,	3 "	3 "
<i>Bambuseæ</i> ,	3 "	5 "

It is thus seen that all of the generally recognized tribes excepting the Phalarideæ are represented. The largest genera are *Panicum*, with 30 species; *Andropogon*, with 46; *Ischæmum*, 19, and *Eragrostis*, 17. There is a notable absence of certain of our best known genera, e. g., *Agrostis*, *Bouteloua*, *Poa*, *Bromus*, *Agropyron* and *Elymus*. On the other hand, in addition to those already mentioned, there are species of many of our common genera, e. g., *Aristida*, *Avena*, *Chloris*, *Hordeum*, *Paspalum*, *Setaria*, *Sporobolus*, etc. Some of the Indian species have come to us as weeds or cultivated plants, e. g., *Panicum*, (*Syntherisma*) *sanguinale*, *P. crus-galli*, *P. miliaceum*, *Setaria* (*Ixophorus*) *glauca*, *S. (I.) verticillata*, *Polypogon monspeliensis*, *Sporobolus indicus*, *Avena fatua*, *Cynodon* (*Capriola*) *dactylon*, *Eleusine* (*Leptochloa*) *muconata*, *Eragrostis major*, *E. minor*, *E. pilosa*. Two species, viz., *Panicum proliferum* and *Ihragmites*

*communis*, which occur in India, appear to be indigenous to North America also.

It is unfortunate that but 400 copies of this useful list were ordered to be printed by the Bombay government.

CHARLES E. BESSEY.

THE UNIVERSITY OF NEBRASKA,  
LINCOLN, NEBR.

SCIENTIFIC NOTES AND NEWS.

MR. CHARLES A. SCHOTT, Chief of the Computation Division of the Coast and Geodetic Survey, has been awarded the Wilde Prize by the French Academy, which is conferred on the one judged the most worthy from among those who make discoveries in or write works on astronomy, chemistry, geology, physics or mechanics. The award to Mr. Schott is supposed to be based on his work on terrestrial magnetism.

A COURSE of public lectures will be given at Columbia University, between December 5th and 16th, on every afternoon except Saturday and Sunday, by Professor William K. Brooks, head of the department of zoology at Johns Hopkins University. The lectures are to be on 'The Foundations of Zoology,' and while popular in form will present the results of the latest scientific generalizations, together with some account of the men by whom the results in this branch of science have been obtained. The lectures will be given late in the afternoon at Schermerhorn Hall.

THE U. S. Fish Commission Steamer *Fish Hawk* is working, under the direction of Professor Hermon C. Bumpus, in Narragansett Bay and the waters around Block Island. Several questions connected with the breeding habits and distribution of the star fish, and incidentally other problems connected with the marine fauna, are receiving considerable attention. Since the boat has returned from Cuba she has been thoroughly repaired, and is now fully equipped with her customary apparatus for work along the shore line. Lieutenant Commander Richard G. Davenport, of the U. S. Navy, is the commanding officer.

AT a meeting of the Board of Ordnance and

Fortification, on November 10th, it was decided to institute an investigation of the possibilities of flying machines for reconnoitering purposes and as engines of destruction in time of war, and \$25,000 of the fund at the disposal of the Board was appropriated for the purpose. The experiments will be carried out under the direction of General A. W. Greely, of the Signal Service, who will have the advantage of the advice of Professor Langley.

PROFESSOR J. K. REES, of the Columbia University Observatory, has received recently, from Miss Catherine W. Bruce, of New York City, means for building a special photographic telescope. This instrument will be mounted at Helsingfors, and will be employed by Dr. Donner to make polar trail-plates for Dr. Jacoby, in accordance with the plan suggested by him lately at the Astronomical Conference in Boston (See SCIENCE No. 197, page 451). Miss Bruce also sent Professor Rees funds for carrying on the computing work of the Observatory. Dr. H. S. Davis, in his work on the re-reduction of Piazzi's star catalogue, has been generously aided by the same liberal giver. Most assuredly does Miss Bruce deserve the title of Patroness of Astronomy, for she has scattered her gifts far and wide, but always wisely.

DR. CALMETTE, Director of the Pasteur Institute of Lille, has given to that institution a donation of 250,000 francs. The money is to be applied provisionally to the defraying of building expenses till the municipal council is in a position to vote the sums, and is then to be employed in the purchase of material for new researches, or for the maintenance of students making original researches in the laboratory. Dr. Calmette states that his gift represents the profits accruing to him from the application of one of his discoveries in a large distillery at Seclin.

A BRONZE tablet, with a bust in relief, in memory of the eminent physicist Neumann, who died in 1895, has been unveiled in the Hall of the University of Königsberg, in commemoration of the hundredth anniversary of his birth.

SIR W. H. WHITE, Chief Constructor of the British Navy, has been nominated as President of the British Institute of Mechanical Engineers.

DR. JOHN WILLIAM TOORE has been elected President and Dr. W. J. Smyly Vice-President of the Royal College of Physicians in Ireland for the ensuing year.

THE following is a list of those who have been recommended by the President and Council of the Royal Society for election into the Council for the year 1899 at the anniversary meeting on November 30th: President, Lord Lister; Treasurer, Mr. A. B. Kempe; Secretaries, Professor Michael Foster and Professor A. W. Rücker; Foreign Secretary, Sir Edward Frankland; other members of the Council, Professor T. G. Bonney, Captain E. W. Creak, R.N., Professor D. J. Cunningham, Professor James Dewar, Professor W. D. Halliburton, Professor W. A. Herdman, Mr. Victor A. H. Horsley, Dr. J. Larmor, Professor N. S. Maskelyne, Sir Andrew Noble, Professor E. B. Poulton, Dr. W. S. Russell, Professor Arthur Schuster, Mr. D. H. Scott, Dr. Stouey and Professor J. J. Thomson.

A STATUE of Volney was unveiled on October 31st in the French village of Craon, where he was born in 1757. It will be remembered that Volney was a traveler and geographer, though he is doubtless better known for his quasi-philosophical publications and political activity.

THE death is announced of Professor Michele Stefano de Rossi, Director of the Seismographic Observatory at Rome.

MR. LATIMER CLARK, known for his contributions to applied electricity, died on October 28th. We learn from a notice in the *London Times* that he was born in 1822 at Great Marlow, and gained his first practical experience in railway engineering in 1847, as resident assistant engineer under Robert Stephenson at the building of the Britannia and Conway tubular bridges. Of these he published a description a few years later. He next entered the employment of the Electric Telegraph Company, and from assistant engineer rose to be engineer in-chief. In this capacity he superintended the construction of much of the telegraphic system of Great Britain, and in 1854 introduced the device of pneumatic despatch tubes for the transmission of messages, which



are now extensively used by the Post Office. As a member of the committee instituted in 1869 by the government, in consequence of the numerous failures of submarine enterprises, to inquire into the question generally, he was of great assistance to the cause of oceanic telegraphy, and, in addition to the help he was able to give the committee as an ordinary witness, put in a valuable supplementary report on the determinations of the laws of electric currents in submarine cables, which embodied the results of his own practical experience and experimental work. In 1860 he entered into partnership with Sir Charles Bright, and many of the cable enterprises carried out during the ensuing ten years were under their supervision as consulting engineers. A joint paper by them, contributed to the British Association in 1861, was the means of putting electrical measurement on a firm basis. After it had been read, Sir William Thomson, now Lord Kelvin, obtained the appointment of a committee to devise a national system of electrical units, and the result of its labors was the absolute system now in universal use, the terms volt, ampere, ohm, etc., being adopted according to suggestions made in Bright and Clark's paper. The 'Elementary Treatise on Electrical Measurement,' which has become a standard work, appeared in 1868, and a few years later Mr. Clark, in conjunction with Mr. R. Sabine, published 'Electrical Tables and Formulæ.' In 1873 he described the Clark standard voltaic cell, which has proved of great value in promoting accurate measurements of electrical potentials.

THE plan of appointing a commission to study questions relating to the Colonial Botanical Gardens and Experimental Stations of France, which we noted last week, has been carried into effect, and its scope has been extended to include gardens in France. M. Milne-Edwards, Director of the Paris Museum of Natural History, has been appointed President of the Commission.

THE general committee appointed to commemorate the thousandth anniversary of the death of Alfred the Great have resolved, "That the national memorial decided on at the Mansion-house meeting of March 18th shall be at

Winchester and consist of a statue of King Alfred, together with a hall to be used as a museum of early English history." It was estimated that £30,000 would be required for this purpose.

THE United States Civil Service Commission announces that it has received information from the War Department that the necessity for the employment of electrical engineers at New York City and Fort Caswell has practically ceased for the present, and the Commission, therefore, has canceled the examination announced to be held on December 6, 1898. Hereafter the subject of electrical engineering will be an optional subject in junior civil engineer examinations for the Engineer Department at Large (War Department), so that persons qualified as electrical engineers may have an opportunity to have their qualifications tested. The junior civil engineer examination will be given next spring. Applications and information in regard thereto may be obtained after January 15, 1899.

THE position of seed-testing clerk, Division of Botany, Department of Agriculture, will be filled by a civil service examination on December 6th. The chief subject of examination will be practical questions and trials in seed-testing, but the examination will also include structural botany and translations from scientific botanical German into English.

THE International Geodetic Conference met at Stuttgart on October 3d for the first time since its reorganization at Berlin in 1895. Fifteen States of the twenty-two belonging to the Association were represented by official delegates. Probably the most important work accomplished was arranging for the erection and conduct of six stations for the systematic study of variations of latitude. These stations will be at Cincinnati, Dover and Ukiah (Cal.), in the United States; Mizusawa, in Japan; Tschardjoui, in Central Asia, and Carloforte, in Sicily.

FOUR further congresses have arranged meetings in connection with the Paris Exposition of 1900: A congress on railways, a congress on navigation, a congress on the strength of materials and a congress on appliances for

steam engines. The first two congresses are already organized, having held previous meetings. The two latter will hold their first meetings at Paris.

AN International Exposition of Horticulture will be held at St. Petersburg from the 17th to the 27th of May, 1899.

THE Executive Committee of the National Pure Food and Drug Congress have issued a call for a meeting at Washington on January 18, 19, 20 and 21, 1899.

THE annual meeting of the Nebraska Academy of Science will be held on November 25th and 26th, in the Botanical Lecture Room of the University of Nebraska, in Lincoln. Dr. H. B. Ward is the President, and Professor G. D. Swezey, Secretary.

A CONFERENCE of teachers of chemistry will be held at the University of Michigan, December 27, 1898. This is the sixth of these annual conferences of teachers of chemistry in high schools and colleges. The meetings will continue for two days, the subjects being confined to educational methods and matters. Several reports of committees will be presented for discussion. The program will be sent on request by any member of the Committee of Arrangements, namely: Professor Nef, of the University of Chicago; P. H. Seymour, late of the Detroit high school, and Professor Prescott, of the University of Michigan, Chairman.

THE first evening promenade was held at the Royal Botanic Gardens, Regent's Park, November 2d. The string band of the First Life Guards performed a selection of music in the large conservatory, which was illuminated with fairy lamps, and in which there was also a fine show of chrysanthemums. The new club rooms, which will be formally opened shortly, were freely used by the Fellows and members of the Society.

It appears from the final report of the Congress of the Sanitary Institute, held in Birmingham in September, that the number of tickets issued exceeded that of any previous year, and the attendances were in like proportion. The total number of tickets issued was 1,979, as compared with 1,531 at Leeds last year, 1,225 at Newcastle in 1896, and 1,214 in Liverpool in

1895. The number of visitors to the Health Exhibition this year was 85,212, and was 10,000 greater than had been previously attained.

THERE seems to be a misunderstanding in the medical journals in regard to the usual attitude of men of science toward patents. Referring to the Behring patent of antitoxin in America, a writer in the Berliner *Tageblatt* asked what would have become of the ophthalmoscope if Helmholtz had made a claim to patent his invention. Behring replied that Helmholtz could not do this, because there were at that time no patent laws. The New York *Medical Record* says that Behring traduces the memory of Helmholtz, probably not being aware that it thereby traduces the names of many eminent men of science, including Lord Kelvin and Professor Rowland, who each hold dozens of patents. The question of patents by scientific men is one that deserves consideration and discussion. There is certainly no reason why men of science should not profit from their inventions, but there is a real danger if they undertake to do so lest they may be diverted from scientific to purely technical work. But it is nonsense to speak as the *Medical Record* does of the 'misdeeds' and 'depravity' of Professor Behring. Is not the *Medical Record* copyrighted?

MRS. MILLS, the 'Christian scientist,' who treated the late Harold Frederick in his interest, has been held by a verdict of the Coroner's jury on a charge of manslaughter.

#### UNIVERSITY AND EDUCATIONAL NEWS.

ACCORDING to the twenty-fifth quarterly statement of the President of the University of Chicago, there were 1,421 students in attendance during the summer quarter, of whom 591 were in the graduate schools. The assets of the University are valued at about \$9,000,000. The income was \$706,973 and the expenditures \$678,399. An annual report of the University will be published hereafter in the autumn, and the first report to be issued during the present month will contain a *résumé* of the work of the University since its foundation.

THE College for Teachers recently established under the University of Chicago, through a gift of Mrs. Emmons Blaine of \$5,000 a year for five

years, is not intended to prepare teachers for their profession. The plan is to offer an opportunity to do college work to the 5,000 teachers or more of Chicago. The College will not concern itself with methods of instruction, but only with the subject-matter.

MR. HOLYOKE COLLEGE has received \$100,000, bequeathed some time since by the will of the late Charles P. Wilder; one-half of this sum is to be spent in the support and extension of scientific work.

THE new buildings of the medical department of the University of California, built by the State on land presented by the late Adolf Sutro, were formally opened on October 22d. The site, though somewhat remote from the present center of the city of San Francisco, commands a magnificent view, and the laboratories and lecture rooms are excellently equipped.

WE noted last week that eleven architects had been selected in the final competition for plans for the buildings of the University of California instituted by Mrs. Hearst. It appears further that] the [traveling expenses of these architects are to be paid by Mrs. Hearst in order that they may proceed to California and spend six months in adjusting their plans to the magnificent site of the University.

A CHAIR of physical geography, not yet filled, has been established in the University of Zurich.

THE University of Paris has been given anonymously a fund to allow a French student to study mathematics in Germany.

AT Magdalen College, Oxford, Mr. Horace Middleton and Mr. Harold Hilton have been given fellowships, the former in reference to work in physiology and zoology, the latter with reference to work in mathematics.

M. BOIRAC has been appointed professor of philosophy at Dijon.

THE Council of the University of Paris has nominated for lecturer in experimental psychology as its first choice M. Pierre Janet and as its second choice M. Georges Dumas.

DR. R. LORENZ, electrochemistry, and Dr. K. Keller, zoology, have been made full professors in the University of Zurich.

#### DISCUSSION AND CORRESPONDENCE.

##### THE 'BIPOLARITY' HYPOTHESIS.

I HAVE read with interest Dr. Ortmann's remarks in SCIENCE for October 14th on Sir John Murray's views as to the distribution of marine faunas. I agree with Dr. Ortmann that in most cases the supposed 'bipolarity' does not exist, and I may refer him to some remarks of my own published last June, which show very much the same for the Tunicata as he does for the Crustacea. The statements in question appear in a paper on Simple Ascidians from Puget Sound (Trans. Biol. Soc., Liverpool, Vol. XII., p. 248), in which, while pointing out the close similarity between the Tunicata faunas of the west coast of Europe and North America and their possible relation to a northern circumpolar fauna, I criticised Murray's 'bipolar' lists and gave as my opinion that "the distribution of Tunicata as a whole does not lend any support to the bipolar hypothesis." I further stated that "this matter must be settled by specialists in each group of animals stating their opinions as to the genetic affinities of the northern and southern faunas in their own groups, quite apart from and uninfluenced by general lists containing other groups." I am glad to see that this is what Dr. Ortmann and others are now doing.

I would add: There is one thing more we need, and here I am sure Sir John Murray and other naturalists will concur, and that is, more facts, further investigations. There is every prospect now, with the various Antarctic expeditions in the field or proposed, that we shall shortly be in possession of more information from the far South. It is to be hoped that American and British naturalists will see to it that our own polar seas are more thoroughly explored in the near future, both by dredge and tow-net. In advocating Antarctic expeditions we must not forget how much still remains to be done within the Arctic Circle.

W. A. HERDMAN.

UNIVERSITY COLLEGE, LIVERPOOL,  
October 22, 1898.

PERIDINIUM AND THE 'RED WATER' IN NAR-  
RAGANSETT BAY.

DURING the last two months the inhabitants of Rhode Island witnessed the following remark-



able phenomenon. The water of a considerable portion of the Bay became thick and red, emitting an odor almost intolerable to those living nearby. The situation became alarming when, on the 9th and 10th of September, thousands of dead fish, crabs and shrimps were found strewn along the shores or even piled up in windrows.

At the request of the Rhode Island Commission of Island Fisheries, an investigation was made to determine the cause and extent of the unusual color of the water and of the great mortality of the fish. The results of this investigation are briefly as follows:

During the last of August, throughout September and a part of October streaks of red or 'chocolate' water were observed from near Quonset Point and Prudence Island, north to Providence, and, on the flood tide, up the Seekonk River, nearly to Pawtucket, a range of about fifteen miles. In other parts of the Bay, as far as could be learned, the phenomenon had not been observed.

On the 8th and 9th of September the water became extremely red and thick in various localities from East Greenwich to Providence, and the peculiar behavior of the marine animals attracted much attention. Myriads of shrimps and blue crabs, and vast numbers of eels, menhaden, tautog and flatfish came up to the surface and to the edge of the shore as though struggling to get out of the noxious water. Indeed, the shrimp and crabs were observed actually to climb out of the water upon stakes and buoys and even upon the iron cylinders which support one of the bridges and which must have been very hot in the bright sun. In several instances, on these two days, hundreds of blue-crabs were caught by a single individual in a few minutes' time, at the mouth of the Seekonk.

On the following day, September 10th, and for several days afterwards, hardly a live crab or shrimp could be found. Along the shores, however, in the same vicinity, cartloads of dead shrimp were piled up in windrows, and among them were strewn great numbers of crabs and fish of various kinds, especially menhaden and eels. This singular behavior and alarming mortality of marine animals was reported from nearly every station at which the red water oc-

curred, and from no other station, which indicates that the two phenomena are related as cause and effect.

It was commonly believed that dye-stuffs or other refuse emptied into the rivers at the upper part of the Bay gave to the water its color and unpleasant odor, but microscopic examination showed that the water was swarming with minute organisms, a species of *Peridinium*. The *Peridinium* is reddish brown in color and occurred in such excessive abundance that it gave to the water its peculiar color and odor, besides making it so opaque that one could hardly see a white shell six inches below the surface.

With regard to the systematic position of this organism there is a difference of opinion. It is, in fact, ranked with the animals by some authors and with the plants by others. I have not yet been able to determine the species of our *Peridinium*. It resembles in many respects Carter's *Peridinium sanguineum*; it is much flattened, and the anterior end is distinctly bilobed, like *Peridinium tabulatum*, though the lobes are more rounded. Besides a flagellum extending forward from the ventral groove, a very large flagellum lies in the equatorial sulcus and entirely encircles the body. No cilia could be demonstrated.

After September 9th and 10th, when the great mortality of fish occurred, the *Peridinium* became, for a few days, less abundant, and then increased again until the 23d. There was a heavy rain on the 23d, and on the following day the water was comparatively clear. Since this date it has been more or less in evidence up to the day of writing (October 7th). On September 21st the number of *Peridinium* per cubic centimeter in the Seekonk River was estimated at 5,880. This was enough to give the water a very noticeable red color. Nevertheless, the marine animals appear not to have been seriously affected since September 10th or 11th, though the approach of a streak of red water has, in some instances, interrupted good fishing.

In the Seekonk River the shrimp and crabs gradually returned, and in about three weeks after the sudden mortality were nearly as numerous as before, though the water was at times distinctly colored. On the 23d some shrimp, oysters and small fish (*Fundulus*) were

kept in the water where the *Peridinium* were the thickest, and suffered no apparent injury. In consideration of these facts, it has been doubted whether the *Peridinium* was the immediate cause of the peculiar behavior and death of the fish which occurred on the 9th and 10th of September, especially as the weather had been phenomenally hot for several weeks previous to that date. I believe, however, that the *Peridinium* was the cause of the trouble, and not the hot weather nor manufacturers' waste, for the following reasons :

On the two or three days in which the mortality took place the water was extremely red.

The hot weather was followed by a cold wave a day or two before the mortality commenced.

The phenomena occurred in Greenwich Bay and off Nayatt, many miles from any considerable source of contamination.

Finally, the phenomena in question were noticed by very many persons throughout the whole range of the red water, while in neighboring portions of the Bay, for example, in the Warren River and in Bristol Harbor, where the temperature of the water is quite as high as in the red-water districts, no *Peridinium* and no mortality or unusual behavior of the marine animals was reported, though the regions were carefully canvassed.

There are many recorded instances of salt and of fresh water colored red probably by *Peridinium* of this or a similar species. H. J. Carter, in his account of 'The Red Coloring Matter of the Sea round the Shores of the Island of Bombay,' described the new species *P. sanguineum*, which produces this effect. He points out, also, that Darwin's description of the animalcule which he found to color the sea red, a degree south of Valparaiso, accords exactly with that of *Peridinium*. The animalcules which, according to Salt, produce the red color in the Red Sea, may also be due to this form, and the same cause may perhaps be ascribed to the red color of the sea off Iceland in 1649. Porter quotes "the following passage from an eye witness of a similar occurrence at Porebunder, on the coast of Khattywar, India, where the red water is extremely common, viz.: 'the color of the sea water on Saturday evening last, the 27th of October, 1849, was changed

from its usual tint to a deep red, emitting a most foul smell; the fish speedily were all destroyed and washed upon the beach in large quantities, etc.' " Though the narrator believed that this might be due to a submarine eruption of mud, Mr. Carter is inclined to ascribe it to some 'animalcule,' most probably *Peridinium*. He also directs attention to the Mosaic account of the plague of Egypt given in the following verses: "And all the waters that were in the river were turned to blood." "And the fish that was in the river died; and the river stank, and the Egyptians could not drink of the water of the river; and there was blood throughout all the land of Egypt."

A. D. MEAD.

#### ZOOLOGICAL BIBLIOGRAPHY.

TO THE EDITOR OF SCIENCE: The report on Zoological Bibliography, summarized in your issue of November 4th, is evidently conceived primarily from the point of view of the bibliographer, but from that of the working zoologist it is open to criticism in several details. Chief among these is rule 3, in which the standpoint is made especially conspicuous from the unwarranted assumption that the publication of the separate papers of a volume before the volume as a whole is issued is 'improper,' while the indefinite delay of their publication is 'proper.' It seems to the writer that the propriety or impropriety really consists in the indefiniteness of date, which may or may not accompany the separate publication. This may be, and should be, avoided in a much more simple and easy manner than the remedy proposed by the committee. It is only necessary that the separates as issued should each bear its own date and that the table of contents issued with the volume should state under each title 'author's copies issued' at such and such a date. For the progress of science, as well as the convenience of workers, it is much more important that separate papers should be promptly issued and distributed to specialists than that the volume should be issued at all. The above method has been employed by the Philadelphia Academy of Natural Sciences, and the method of separate publication of all papers has been adopted by most of the Washington

societies, as well as the National Museum, to the very great convenience of everybody concerned. I have never found any difference of opinion among working zoologists on this point.

WM. H. DALL.

SMITHSONIAN INSTITUTION, November 5, 1898.

#### THE NERNST LIGHT.

TO THE EDITOR OF SCIENCE: Several months have passed since the report of the discovery of a new incandescent electric light by Professor Nernst, of Göttingen. It was rumored that a Berlin firm had bought the patent for five million Marks, and that we were on the eve of another revolution in the illuminating industry, but till recently very little reliable information has been obtained. In the meantime Professor Nernst has been developing and perfecting his invention, and his researches have been crowned with such success that we may look forward to the early appearance of the finished lamp, and perhaps the confirmation of the most sensational rumors.

The astonishing progress in illumination during recent years has been characterized by a great race between gas and electricity. Scarcely had the incandescent light secured a firm hold in the practical world when Auer von Welsbach made his famous improvement on the gas light, and the possibility of the use of acetylene became apparent, so that many believed electricity would after all have to yield the supremacy to gas. Nernst now reclaims the palm for electricity, for he expects that the cost of his light for a whole evening will be no more than that of the Edison for an hour.

The Nernst light requires neither vacuum nor tender filaments. The essential point of the invention is that when substances like magnesia (magnesium oxide) and clay are heated above 3,000 degrees Celsius (6,000° Fahr.—far above the melting point of platinum) a very weak current is sufficient to keep them in an intensely luminous condition. Either direct or alternating currents may be employed, and the magnesia is little injured by use. The only difficulty that remains to be surmounted is a practical and inexpensive appliance for heating the substance to the necessary temperature. The work is, however, progressing and those who

know the ability and courage of the inventor are confident that he will succeed.

Professor Walter Nernst, though unknown to most people, is a scholar of high rank in the purely scientific world, and his works or their translations are to be found in almost every scientific library. His brilliant researches won him the newly established chair of physical (theoretical) chemistry at Göttingen, and he is surrounded by advanced students of the most varied nationalities, all of whom greatly admire his fertile mind and genial, inspiring manner. His new invention is but another example of the benefit that patient, conscientious scientific study is sure to bring to the whole world.

H. C. COOPER.

HEIDELBERG.

#### THE DAY OF THE WEEK.

TO THE EDITOR OF SCIENCE: The statement made in your issue of SCIENCE for October 18, 1898, by Mr. Edward L. Stabler, that 'I have not found any published rule for the simple problem of determining mentally the day of the week without reference to a calendar or lengthy table' leads me to send you the following formula, which I have never seen in print, but which is of so simple derivation that it may well have been used by others than myself.

Let  $Y$  represent any year of the Gregorian calendar and  $D$  the number of any day in that year, *e. g.*, for February 1, 1898,  $Y=1898$  and  $D=32$ . Neglecting fractions, put

$$Y + D + \frac{Y-1}{4} - \frac{Y-1}{100} + \frac{Y-1}{400} = 7n + r$$

where  $n$  is the quotient and  $r$  the remainder obtained by dividing the first member of the equation by 7. The remainder  $r$  then represents the number of the day of the week, *e. g.*, if  $r=1$  the given date falls on Sunday, etc., and if the division is exact,  $r=0$ , it falls on Saturday. For the date given above we have

$Y$	1898
$D$	+ 32
$(Y-1)/4$	+ 474
$(Y-1)/100$	- 18
$(Y-1)/400$	+ 4
	7)2390
$n$	341
$r$	3 = Tuesday.



Dates given in the Julian calendar must first be transformed to the Gregorian calendar before applying the above formula, and this transformation is readily effected through the relation

$$G = J + (N - 2) - \frac{N}{4}$$

where  $G$  and  $J$  are the respective dates,  $N$  is the number of the century, and the remainder is to be neglected in the division by 4.

GEO. C. COMSTOCK.

WASHBURN OBSERVATORY,  
MADISON, WIS., October 31, 1898.

#### NORTHERN ROCKY MOUNTAIN GLACIERS.

TO THE EDITOR OF SCIENCE: For some years I have been interested in the geography of a small section of the Rocky Mountains which, until recently, was part of the Blackfeet Reservation, in northwestern Montana. This section lies, for the most part, east of the Continental Divide and between the international boundary on the north and the Great Northern Railroad on the south. The portion of it which I know best is included in the watershed of the St. Mary's River and its tributaries. In 1891 I took to the head of the St. Mary's River the first party that had ever visited it, so far as known, and in 1895 accompanied to the same point the Government Commission which afterwards purchased from the Blackfeet Indians the rough mountain land which formed the western portion of the reservation of that tribe. Before that I had made a sketch map of the region, which is the basis of all the maps of it that have been made or published.

In 1897 I made a hasty trip to the head of the river and climbed Mt. Jackson, the highest peak in that region. Last July (1898) I again went to the head of the river and climbed the Blackfoot Mountain, another lofty peak somewhat less accessible than Mt. Jackson. On both trips I was accompanied by my friend, Mr. J. B. Monroe.

These last trips have enabled me definitely to locate two points about whose relations I have never until now been quite certain. One is the Pumpelly glacier, discovered by Professor

Raphael Pumpelly, who, I believe in 1883, with a small party which included the late W. A. Stiles, crossed from the Flathead country to the Plains by way of the Marias, or, as it is now called, the Cut Bank Pass. This great mass of ice, which is seen by every traveler going through the Cut Bank Pass, rises to the height of several hundred feet above the face of a lofty cliff, over which portions of the glacier are constantly falling with tremendous reports, which are heard for a long distance.

From the top of the Blackfoot Mountain the whole country leading up to the Cut Bank Pass can be seen, and immediately below it to the southeast lies the Pumpelly glacier, readily identified not only from its position with relation to the valley, but also by the peaks and rocks in its neighborhood. It thus appears that the Pumpelly glacier, as I have long supposed was the case, is part of the southern flow of the great ice cap which covers almost the whole of the Blackfoot Mountain. The Blackfoot glacier, which stretches away in a northeasterly direction from the peak of the Blackfoot Mountain, though perhaps varying in extent somewhat with the season, was estimated last July to be six or seven miles long, and in some places between three and four miles wide. From the peak of the Blackfoot Mountain the ice field flows also in a northerly direction, meeting another which runs down between Mt. Kainah and Mt. Jackson, while from Mt. Jackson a number of smaller glaciers flow down to timber line.

A little to the west of south of the Blackfoot Mountain and lying in a great bend of Mud Creek — tributary of the Flathead — which entirely cuts it off from the main range, lies Mt. James, one of the three highest peaks in this immediate section. Seen from the east, it is shaped like the square-faced, peaked end of a hay stack, and at a distance appears very difficult or impossible of ascent. Its southern and western faces may be more practicable than those on the north and east appear. From the top of the Blackfoot Mountain the level shows Mt. Jackson to be the highest of all these mountains; Mt. James the next, while Blackfoot is the third. But the differences in height are very slight.

A few miles northwest of Mt. Jackson, and

lying on the west side of the range, lies a little basin named Avalanche Basin by Mr. L. B. Sperry, of Oberlin, Ohio, and on the mountains overlooking this, Mr. Sperry tells us, are extensive snow fields and a glacier. From the summit of Blackfoot Mountain it appears that this Avalanche Basin lies nearly south of Mt. Piegan of my map, and southwest of Mt. Reynolds. I understand that Mr. Sperry, who was, of course, unaware that the mountain had been earlier named, has called Mt. Reynolds Matterhorn from the slender—as seen from the southwest—finger of rock which forms its peak. Mt. Reynolds is in the Continental Divide, although most of the recent maps wrongly place it east of the Divide.

If the locations of the Pumpelly glacier and of Avalanche Basin with regard to definite and well-known points in the Continental Divide are thus established, the matter is one of some interest to students of this section of the northern Rocky Mountains, since hitherto, so far as I am aware, the relations of the east and west sides of the range have not been known between the head of Belly River and the Cut Bank Pass.

Lying nearly to the south of Mt. Jackson, and between it and the Blackfoot Mountain, is a deep basin which is the head of Harrison Creek, flowing down toward the Flathead Lake. This basin, which I have called Pinchot's Basin, is occupied by a large glacier, which is fed by many smaller ones flowing down the steep side of Mts. Jackson, Kainah and Blackfoot. What the extent of this glacier may be I do not know, but lying in this deep basin, and almost completely surrounded by high mountains, the area of the moving ice must be very considerable.

GEO. BIRD GRINNELL.

#### SCIENTIFIC LITERATURE.

*Outlines of the Earth's History.* By N. S. SHALER. D. Appleton & Co. 1898. Price, \$1.75.

This 'Popular Study in Physiography' is the latest of a number of attractive publications dealing with geological and geographical themes, from the pen of the professor of geology at Harvard. As in the case of the 'Aspects of the Earth,' published in 1889, the pres-

ent volume of over four hundred pages is a series of essays on some of the broader phases of the earth's history.

Popular scientific books, well written, clearly printed and attractively illustrated, are year by year becoming more and more numerous, and are taking the place of novels, especially among the more intellectual and cultivated readers. It is to this as yet small library of nature-novels that the 'Outlines of the Earth's History' belongs.

The nine essays comprising the volume and forming as many chapters are:

- I. An introduction to the study of nature.
- II. Ways and means of studying nature.
- III. The stellar realm.
- IV. The earth.
- V. The atmosphere.
- VI. Glaciers.
- VII. The work of underground water.
- VIII. The soil.
- IX. The rocks and their order.

As may be seen from this outline, the volume, although embracing a wide view of nature, is not a systematic treatise, and does not fill the place of a text-book on physiography. It is a collection of graphic essays, each of which may be read separately without detracting from its value, designed to lead the reader by easy paths to a sufficiently elevated, intellectual standpoint, to command a comprehensive view of what the author terms the natural realm.

Following the first two chapters, which are of the nature of an introduction, dealing briefly with the ways in which barbarous and civilized men view their surroundings, and suggesting methods to be pursued in nature study, comes a description of the stellar realm. Most of the material in this third chapter is of necessity borrowed from astronomy, and presents, among other discussions, a clear statement of the nebular hypothesis, as formulated by Kant and Laplace. But scant, if any, attention is given, however, to the modification of this explanation of the earth's origin, presented especially by Lockyer and known as the meteoric hypothesis. A reason for this omission is perhaps to be had later in the book, where it is stated that meteors may possibly have been ejected by volcanoes of our own and other planets, a view

that is not shared by many students of nature. As meteors are still coming to the earth, and everyone has seen 'shooting stars,' the meteoric hypothesis, by appealing to a process still in action, by which the earth may have been formed, is particularly attractive as a subject for popular presentation.

The chapter on the atmosphere contains not only an instructive summary of some of the leading facts concerning the outer envelope of the earth, but, overstepping all stereotyped methods, deals also with the changes which the movements of the air, and the circulation of water vapor in it, make upon the seas and lands beneath. The freedom in this connection that a popular essay seems to demand, is indicated by the variety of themes embraced in this discussion of the atmosphere. These are 'whirling storms;' 'the system of the waters,' including the waters stored in the earth or rock-waters, the nature and origin of tides, the action of shore waves, the character of sea beaches and cliffs, etc. 'ocean currents,' their influence on climate and on the distribution of life, and connection with past geological changes; 'the circuit of the rain;' 'the geological work of water;' under which falls the sculpturing of the land by streams; and 'lakes.' Such a highly complex group of subjects in a chapter of one hundred pages, while not to be tolerated in a systematic treatise on physiography, does not seem out of place in a story book of nature. Systematic works are apt perhaps to impress one with the view that the operation of natural forces are independent and stand alone, each complete in itself, but a more general view, in which their mutual dependence and interaction are made prominent, is no doubt best for popular presentation. However comprehensive a book may be, one essential is that facts and principles should be accurately stated. Here enters one of the leading difficulties in popular writing. For example, on page 101, in describing the ascent of warm air in circular storms, the draft in a chimney is introduced as an illustration, and the statement made that 'the heated lower air breaks its way up the shaft, gradually pushing the cooler matter out at the top,' and, later, 'wherever the air next the surface is so far heated that it may over-

come the inertia of the cooler air above, it forces its way up through it in the manner indicated in the chimney flue.' Now, does the warm air rise and force its way through the cooler and denser air above, by reason of any force inherent in itself; is it not that the attraction of the earth is less, volume for volume, for warm than for cold air; the former being forced to rise by the denser air following under it and forcing it upward.

In this same connection attention may be directed to certain statements which, as the saying is, would 'puzzle a mathematician.' In discussing the flattening of the earth at the poles, page 82, we read, 'the average *section* at the equator being about twenty-six miles greater than that from pole to pole.' Again, in writing of the rebound of a marble when dropped on the floor, page 366, it is stated that the marble becomes 'shorter in the axis at *right angles to the point* which was struck;' also, on page 369, occurs the statement that the 'movements of this wave are at *right angles to the seat* of the originating disturbance.' The italics are by the present writer, and meant to emphasize the opinion that these statements are unintelligible.

One aim in popularizing science is to root out superstitions and in their place, if possible, substitute rational explanations. In this connection Shaler strikes a blow at the time-honored 'Jack-o'-lantern' or 'Will-o'-the-Wisp' which many of us have been looking for in vain since childhood. This ancient spook needs to have better credentials, or else forever disappear from our swamps; or, more accurately, its uncertain light should be dispelled from men's fancies.

The breadth of view and comprehensive character of the remaining essay on glaciers, the work of underground water, the soil, etc., is perhaps sufficiently indicated by the statements just made in reference to the complex groups of phenomena discussed in the chapter devoted to the atmosphere.

Throughout the book there is an aim to cultivate what has been termed the scientific use of the imagination, or the power of forming mental visions of the relations of matter, space, time, etc., which are beyond the power of the eye to grasp, and transcend daily experience.



The earth, for example, as it would appear to an observer on the moon, with the daily passage of its continents from light to shadow, and annually recurring seasonal changes, requires an exercise of the imagination of a high order. In a similar way, various hypotheses to account for the origin of the earth, the larger movements of the atmosphere and of the ocean, the flow of glaciers, the origin of volcanoes, etc., call not only for a knowledge of facts and principles, but the power to group them in the imagination and follow step by step the many changes that are involved. The student of nature has to create in his own mind pictures of the workings of nature ranging in scale from the movements of molecules to the revolution of planets and sidereal systems. It is in this field that the book before us excels. One cannot read its glowing pages without having his imagination greatly stimulated. The rigid boundaries that circumscribe systematic treatises are very properly ignored, and freedom given the imagination to build castles, or rather cathedrals, in the air, to illustrate Nature's architecture.

One phase of the use of imagination in scientific research is the trial by hypotheses. As many plausible explanations as possible of a given phenomena are invented, and the erroneous ones eliminated by careful tests. In this process of multiplying of hypotheses but few men excel the author of the book under review. The search for a true explanation necessitates the destruction of many trial explanations. Every scientific investigator, it has been said, lives in the midst of a cemetery of defunct hypotheses. Strange as it may seem to the uninitiated, every true investigator tries to kill his own hypotheses, in order that only the strong may live. His zeal in this direction being excelled only by the desire to kill the hypotheses proposed by others. In the intangible world of ideas, as in the organic realm, the fittest survive. To most readers of popular science this struggle is practically unknown, and the hypotheses presented to them are accepted as well established laws. For this, if for no other reason, only such hypotheses as have been exposed in the searchlight of criticism, and have been generally accepted by

specialists in the particular field of science to which they pertain, deserve a place in popular-science books. It is in this connection that the volume before us seems most widely open to criticism.

An explanation of the movements of the tides and the flow of glaciers placed side by side before the general reader or the student just entering on the study of nature, are accepted as equally worthy of credence, and are apt to take such firm root in the mind that a shock is felt when one of them has to be modified or rejected.

The explanation of the flow of glaciers, and especially the view that continental glaciers, in their central and deeper portions, float on a cushion of water or of half-melted ice, for the reason, if no counteracting agency exerted an influence, that the ice at the bottom of such a glacier would melt because of the presence of its own mass, the melting point of ice being lowered by pressure, is one of the many attractive hypotheses that have sprung from Professor Shaler's fruitful brain, but one not generally accepted by glacialists. This tendency to give precedence to one's own hypotheses is again manifest in discussing the nature and origin of volcanoes. The changes which water-charged sediments would undergo if depressed to a depth of many thousands of feet (Shaler suggests twenty miles!) is elaborated as the main explanation of the origin of volcanoes. While this hypothesis fascinates the mind, and explains many of the facts observed during volcanic eruptions, notably the vast volumes of steam given forth, it has not withstood the tests of criticism in such a way as to warrant its presentation to the public as the sole and final explanation of volcanic phenomena.

While it is not the province of a reviewer to dwell on typographical errors, I will note one slip for which having been called to account myself, I can warn others against. In the English translation of Palmieri's book on the Eruption of Vesuvius in 1872, a certain gulch on the side of the mountain is called the 'Atria del Cavallo,' the word *atria*, according to the dictionaries, should be *atrio*. This mistake has been repeated on page 285 of the book under review.

While several of the plates reproduced by Shaler are excellent, notably the one of a pebble-beach and the pictures of breakers on the shore of Martha's Vineyard, some of the cuts in the text are decidedly poor. The small woodcut intended, according to title, to represent a sun spot, and another of a portion of the moon's surface, should certainly be replaced by something better in future editions.

In the preface of the volume the statement is made that it is intended for beginners in the study of the earth's history. It seems to the present writer that this claim is too modest, as the book can be used with both pleasure and profit by the advanced student and even by the most experienced veteran in physiography, as well as by the novice. In fact, the many suggestions and original observations, strewn thickly along the general pathways that are followed, are among the greatest charms of the book. Some of these branches of the general current of thought may perhaps lead the beginner astray, but to more experienced explorers they serve to show how vast is the space surrounding the known.

In every library there should be a new shelf for romances of nature, and one of the first books to be placed thereon, whether in the home, school, university or circulating library, should be the 'Outlines of the Earth's History.'

ISRAEL C. RUSSELL.

*Die Chemie in täglichen Leben. Gemeinverständliche Vorträge.* By PROFESSOR DR. LASSAR-COHN. Hamburg und Leipzig, Leopold Voss. 1898. Third Edition. 8vo. Pp. vii+317.

A German book on chemistry which has experienced three editions in as many years, and translations of which into several foreign tongues have been made or are in preparation, as the author's prefaces inform us, must have struck a responsive chord in public favor.

These lectures on chemistry in daily life are twelve in number. They cover a wide range of topics; foods, illuminants, explosives, leather, coal-tar colors, ceramics, Röntgen rays and many other subjects are discussed.

At times the grouping of themes presented in one lecture seems rather incongruous. Thus, in one instance, lecture twelve, metallic alloys,

alkaloids, anæsthetics, anti-pyretics and disinfectants all come in for consideration.

This appears to be rather a varied menu for an intellectual repast, especially if one intends following the author's admonition and dispose of it at one sitting. For the preface says: "As the individual lectures had the customary duration of one hour a corresponding amount of time ought to be devoted to their perusal."

The style is terse and clear; typography and paper good.

FERDINAND G. WIECHMANN.

*Introduction to the Study of Organic Chemistry.*

By JOHN WADE, B.Sc., Senior Demonstrator of Chemistry and Physics at Guy's Hospital. London, Swan, Sonnenschein & Co. 1898.

The author has adopted a method of treating the subject which is exactly the reverse of that commonly employed. He starts not with the simple hydrocarbons, but with some of their derivatives, and does not give the properties, etc., of the hydrocarbon until he has taken up the complex derivatives. As he states in the preface, 'the book proceeds from the familiar to the unfamiliar.' The application of this method can, perhaps, be best shown by an extract from this preface: "The first substances to be studied are the typical alcohol and acid akin to the inorganic bases and acids, and the study of these leads to the theory of radicals. The other simple alcohols and acids are next dealt with, and the ideas of homology and isomerism introduced. The construction of the network of cross connections typical of organic chemistry is now commenced, with the aid of the ammonia derivatives and cyanogen compounds, and the necessity of the theory of structure shown. The structural formulæ of the various compounds having been duly established, the simple aldehydes are introduced, and with them the conception of polymerism; then the simple ketones and secondary alcohols, with the theory of position isomerism; and the iso-alcohols and acids, with the theory of branching-chain isomerism. Finally, the simple hydrocarbons are dealt with, and the preceding work codified in the theory of substitution."

It is difficult to see how one can gain a clear idea of the more complex substances without

an understanding of the simpler member from which it is derived. A knowledge of the present conception of the structure of benzene is certainly necessary in order to understand the isomeric compounds and the formation and reactions of the complex derivatives. The subjects are quite fully developed, with charts to illustrate the relationship of substances to one another, and methods of preparation, for use in a laboratory, are given in an appendix, as is also a short review of the general method of testing for the commoner organic substances. The book is intended evidently for men preparing for Board examinations.

J. E. G.

#### SCIENTIFIC JOURNALS.

*The Journal of Physical Chemistry*, June: Molecular Weights of Liquids, two papers by Clarence L. Speyers. Benzilorthocarboxylic Acid, by C. A. Soch; a study of the two modifications. Analysis of Aqueous Alcohol, by Chester B. Curtis; the method proposed is titration with toluene until milky turbidity appears. The results are as accurate as the pycnometer tests, are simple and rapid. The delicacy of the test increases rapidly with the strength of the alcohol. The Benzoyl Ester of Acetylhydroxamic Acid, by Frank K. Cameron; a study of the two modifications. Boiling-point Curve for Benzene and Alcohol, by E. F. Thayer. October: Benzaldoxime, by Frank K. Cameron. The Isothermal Pressure-surface in the Case of Two Single Salts and one Double Salt, by F. G. Donnan. The Molecular Weight of Orthorhombic, Monoclinic and Plastic Sulphur in Naphthalene and Phosphorus by the Freezing-point Method, by Samuel D. Gloss; from the boiling-point method in carbon disulfid and in benzene, Orndorff and Terasse conclude that orthorhombic and monoclinic sulfur have the same molecular weight; Blitz by the vapor-density method reaches the same result for orthorhombic and plastic sulfur; the author also concludes from a series of determinations by the freezing-point method, using naphthalene and phosphorus as solvents, that the molecular weights of the three varieties of sulfur are the same. The Variance of the Voltaic Cell, by Wilder D. Bancroft; the object of

this paper is to show the way in which the phase rule should be applied to reversible cells, and to call attention to the usefulness of the theorem of La Chatelier in predicting the change of the electro-motive force with the change of the parameters.

THE October number of the *Bulletin of the American Mathematical Society* contains an account of the Fifth Summer Meeting of the Society, by the Secretary: 'Note on the Generalization of Poincaré and Goursat's Proof of a Theorem of Weierstrass,' by Professor W. F. Osgood; 'Supplementary Note on a Single Valued Function with a Natural Boundary, whose Inverse is also Single Valued,' by Professor W. F. Osgood; 'Note on the Periodic Developments of the Equation of the Center and of the Logarithm of the Radius Vector,' by Professor A. S. Chessin; 'The Theorems of Oscillation of Sturm and Klein (Third Paper),' by Professor Maxime Bôcher; 'Notes;' and 'New Publications.' The November number of the *Bulletin* contains a report on the Cambridge Colloquium, by Professor H. S. White; the six lectures on 'Selected Topics in the General Theory of Functions,' delivered before the Colloquium by Professor W. F. Osgood; a report of the Boston meeting of Section A of the American Association for the Advancement of Science, by Professor James McMahon; 'Notes;' and 'New Publications.' Each of the two numbers fills 56 pages.

THE *American Journal of Science* for November contains the following: 'Irregular Reflection,' by C. C. Hutchins; 'Occurrence of Sperrylite in North Carolina,' by W. E. Hidden; 'Description of a Fauna found in the Devonian Black Shale of Eastern Kentucky,' by G. H. Girty; 'Separation of Nickel and Cobalt by Hydrochloric Acid,' by F. S. Havens; 'Contributions to Paleontology,' by F. A. Lucas; 'Value of Type Specimens and Importance of their Preservation,' by O. C. Marsh; 'Origin of Mammals,' by O. C. Marsh; 'Causes of Variation in the Composition of Igneous Rocks,' by T. L. Walker; 'Relation between Structural and Magneto-optic Rotation,' by A. W. Wright and D. A. Kreider.



THE frontispiece of *Appleton's Popular Science Monthly* for November is a portrait of Professor F. W. Clarke, Chief Chemist to the United States Geological Survey, and the number contains an account of Professor Clarke's contributions to the advancement of science. In the first article in the number Professor E. S. Morse asks whether middle America was peopled from Asia and answers in the negative. Mr. C. R. Dodge contributes an elaborately illustrated article on the possible fiber industries in the United States, and there are, as usual, a number of interesting articles relating to different departments of natural and social science.

*Natural Science* announces that it will be transferred to a new editor, who will continue the journal on the same plan as heretofore. Further particulars are deferred until December.

THE jury on 'Imprimerie et Industries de Livre' of the Brussels International Exposition has awarded the *Scientific American* a diploma of merit and a silver medal.

#### SOCIETIES AND ACADEMIES.

##### AMERICAN MATHEMATICAL SOCIETY.

A REGULAR meeting of the American Mathematical Society was held at Columbia University, New York City, on Saturday, October 29th. Thirty-six persons were in attendance, including twenty-nine members of the Society. The meeting extended through two sessions, beginning at 10:30 a. m. and 2:30 p. m. The President, Professor Simon Newcomb, occupied the Chair. The Council announced the election of the following persons to membership in the Society: Mr. E. B. Escott, Grand Rapids, Mich.; Dr. L. B. Mullen, Cleveland, O.; Professor J. M. Peirce, Cambridge, Mass.; Professor Alexander Pell, Vermilion, S. D.; Professor Arthur Ranum, Seattle, Wash.; Mr. A. N. Whitehead, Cambridge, Eng.; Mr. W. C. Wright, Boston, Mass. Five applications for membership were received. The total number of members of the Society is now 315. At the meeting of the Council nominations of officers for the coming year were made, and a report was received from the committee appointed at the preceding meeting to consider the question

of improved facilities for the publication of the result of original research in mathematics in this country.

The following papers were read at the meeting:

1. Professor F. MORLEY: 'A regular configuration of ten line-pairs in hyperbolic space.'
  2. Professor R. S. WOODWARD: 'The mutual gravitational attraction of two bodies whose mass distributions are symmetrical with respect to the same axis.'
  3. Professor E. D. ROE: 'On symmetric functions.'
  4. Professor A. S. CHESSIN: 'Note on the problem of three bodies.'
  5. Professor MAXIME BÔCHER: 'On singular points of linear differential equations with real coefficients.'
  6. Professor E. O. LOVETT: 'Contact transformations of developable surfaces.'
  7. Dr. L. E. DICKSON: 'The largest linear homogeneous group with an invariant Pfaffian.'
- F. N. COLE.

##### BIOLOGICAL SOCIETY OF WASHINGTON.—296TH MEETING, SATURDAY, NOVEMBER 5.

MR. F. V. COVILLE exhibited a specimen of lava from Mt. St. Helens, bearing the impression of the bark of a pine, saying that he had been told of the existence of stumps and logs buried in the lava on that mountain.

MR. ALBERT F. WOODS showed some leaves 'skeletonized' by the small fresh-water crustacean *Cypridopsis*.

MR. H. J. WEBBER noted the occurrence of several sports of a species of *Clarkia* which had borne ripe seeds, a thing rather unusual among sports.

MR. D. G. FAIRCHILD spoke of 'the Dutch Botanical Gardens at Buitenzorg, Java,' illustrating his remarks by photographs. He said that the gardens practically were a biological station, and that in the future they would undoubtedly be much resorted to by students of all nations. In addition to the gardens at Buitenzorg, which comprised 127 acres, about 800 feet above sea level, there was another 'mountain garden' at Tjibodas, some five hours distant, containing a large tract of forest, ranging from 4,500 to 8,000 feet above sea level.

Dr. L. O. Howard described 'the Outbreak of the Fluted Scale in Portugal, and its Results,' stating that the scale had been brought from Australia to the Cape de Verde Islands on *Acacias*, introduced to form windbreaks for the orange plantations, and thence carried to Portugal. In 1896, when the insect had spread over a considerable extent of territory, the Australian Lady-bug was brought from the United States, with the result that within a year it had practically exterminated the scale insect.

Mr. Charles T. Simpson told of 'the Destruction of the Pearly Fresh-water Mussels' in the central United States, saying that their wholesale gathering for pearls and for use in making buttons threatened to exterminate them in many sections, and the injury was aggravated by the drainage of large tracts and by the contamination of the streams by sewage. The speaker briefly described the breeding habits of the two great groups of fresh-water mussels and suggested some remedial measures.

Mr. F. A. Lucas noted 'the Occurrence of Mammoth Remains on the Pribilof Islands,' stating that Mr. R. E. Snodgrass and the party from Stanford University had, in 1897, obtained two teeth of the Mammoth and bones of a bear, apparently distinct from the existing Polar Bear, from a lava cave on Bogoslof Hill. He was of the opinion that possibly the presence of these bones in such a situation might indicate the comparatively recent connection of the island with the mainland.

F. A. LUCAS,  
Secretary.

#### ENTOMOLOGICAL SOCIETY OF WASHINGTON.

November 3, 1898. Under the head of exhibition of specimens Mr. Heidemann showed *Dichocysta pictipes* Champion, originally described from Panama, which has recently been collected in the Santa Rita Mountains of Arizona by Mr. Schwarz. Mr. Schwarz showed specimens of a Pyromorphid moth and a Lampyrid beetle from Arizona which appear identical during flight. He described the peculiar flight habits of both species. Dr. Dyar stated that the mimicry is complicated in this case by the fact that there are three moths, an Arctiid and a Syntomeid in addition to this Pyromorphid, which with the

Lampyrid beetle all look almost exactly alike while flying. Professor Uhler spoke of the progress of his work upon the Capsidæ, showing that from recent collections in Mexico and South America he is beginning to find that many of our United States forms have a much more southern origin than has hitherto been supposed.

Mr. Howard read a paper entitled 'An Insect Breeding in Petroleum,' showing that an Ephydrid fly, described by Mr. Coquillett in connection with this paper as *Psilopa petrolei* n. sp., breeds in large numbers in crude petroleum pools in the neighborhood of oil wells near Los Angeles, Cal. This insect has not previously been mentioned in entomological literature. It has been known to oil men for some time and is referred to incidentally by S. F. Peckham in his 'Report on the Production, Technology and Uses of Petroleum and Its Products' in Volume X., Tenth Census Reports.

Mr. Schwarz continued his paper of the previous meeting on 'Southern Arizona and its Insect Fauna,' speaking especially of the sharp demarcations in the life zones in Arizona on account of the extremely variable altitudes, producing a complexity of zones which is more marked than elsewhere in the United States. He described at length the characteristic features, both botanical and entomological, of the regions mentioned, showing among other interesting points that Dr. Merriam's conclusion that the valley of the Colorado River is tropical is hardly substantiated by a study of the insects. The paper was discussed at length by Messrs. Gill, Howard, Ulke, Pollard, Ashmead and Uhler.

L. O. HOWARD,  
Secretary.

#### TORREY BOTANICAL CLUB, OCTOBER 11, 1898.

The evening was devoted to informal reports of summer observations and experiences. The Secretary spoke of collections in the White Mountains and on the Massachusetts coast and near Lake Erie.

Dr. Britton spoke of the progress made at the Botanic Garden, especially in the advancement of the museum building, and reported the progress

perous condition of the herbaceous garden, now with over 2,700 species, a mass of bloom during the season. One day in July the visitors to the grounds numbered 4,000. Interesting questions of specific identity are being confirmed by cultivation at the Garden, as in the case of *Potentilla pumila*.

Dr. Britton also announced the forthcoming scientific expedition to Porto Rico, Mr. A. A. Heller going as botanist under the auspices of the New York Botanic Garden, through the liberality of Mr. Cornelius Vanderbilt.

Dr. Underwood reported botanical work in the forests of Thuringia, and examination of fern types at Berlin. He referred to the excellent preservation of the plants of Willdenow at Berlin, and to the strength of the Berlin Herbarium, enriched by the work of Prantl, the collections of Mettenius, Maximilian-Kuhn and the Hawaiian herbarium of Hildebrand. Dr. Underwood described the new botanic garden laid out by Professor Engler, near Berlin, exhibiting modern ideas of geographic distribution.

Dr. Rusby reported a summer spent largely in procuring material for the study of drugs in powdered condition. Drugs now come chiefly to the pharmacist powdered, and adulterants are less easily recognized.

It was reported that Professor Henry Kramer, formerly of this Club, had devised a key for powdered drugs. Dr. Rusby's search for genuine *Apocynum cannabinum*, with broad, thick leaves, woolly beneath, has proved disappointing; *A. album*, with recurving habit, replacing it in the region about New York City.

Mr. A. A. Heller spoke of his experience in the Olympic Mountains, where the continuous rains interfered with collections. Ferns grew in great profusion and often five feet high, but of few species. The Salmonberry varied from yellow to deep red and was often an inch in diameter on bushes ten feet high. *Oxalis Oregona* made a fine display, as also several species of *Vaccinium*, *V. parvifolium* with red and *V. ovalifolium* with blue berries. An introduced blackberry, *Rubus laciniatus*, is now well established there, blooming from July to Christmas, and known as the Evergreen Blackberry. *Spiraea Menziesii* grew by the streams, with its rose-

colored spike a foot and a-half high. *Lilium Columbianum* appeared in the meadows. There were not many representatives of any family, only about 20 composites out of 250 plants collected, of grasses 35. Later, Mr. Heller collected in August and September, in Texas and Arkansas, with marked success.

Professor Lloyd reported a summer spent in study in the laboratory of Professor Goebel, at Munich, and commented upon the botanic garden there, which, although of but few acres, is exceedingly well arranged for educational purposes.

Mr. M. A. Howe reported work on the Hepaticæ, and his discovery, on a hemlock stump in the New York Botanic Garden, of genuine *Cephalozia connivens* for the first time in the United States, the plant distributed by Austin under that name proving distinct.

Mr. Clute reported work on the sand barren flora of eastern Long Island. Among his collections were *Dryopteris simulata*, only once before recorded from New York State; *Kneiffia Alleni*, new to North America; *Pogonia verticillata*, in quantity near Southampton; *Kalmia latifolia*, within twenty-five feet of the sea-level; *Potentilla pumila* and *P. Canadensis* growing together without mixing.

Discussion regarding violets followed. Professor Britton exhibited some fresh flowers of *Viola cucullata*, borne on peduncles normally cleistogene, and with some of the flowers transitional in character. President Brown spoke of similar flowering in *V. sagittata*. Dr. Britton and the Secretary reported their collecting cleistogenes of *V. Atlantica* this season for the first time. Mr. Clute described his study of the cleistogenes in *V. cucullata*, *V. ovata*, *V. rostrata* and *V. Canadensis*. They are developed during the heat of summer. Cool temperature seems needed to secure free flowering in *Viola*, as also seen in the greenhouse cultivation of pansies. Mrs. Britton called attention to the continuous summer blooming of *V. tricolor* in the cooler climate of the Adirondacks and of the Alps. Mrs. Britton also reported the collection, at Lake Placid, of *Viola arenaria* for the first time in New York State.

EDWARD S. BURGESS,  
Secretary.



BOTANICAL SEMINAR OF THE UNIVERSITY OF  
NEBRASKA.

In a convocation at the opening of the semester, meetings were appointed for October (papers by Dr. Bessey, Dr. Pound and Dr. Clements), November (symposium on cytology led by Dr. Ward), December (papers by Dr. Ward, Dr. Clements and Mr. Horne), January (symposium on physiology led by Dr. Bessey).

October 22, 1898, papers were read and discussed as follows: 'Recent studies in the arrangement of the families of Protophytes,' by Dr. Bessey; 'A review of Pax's Pflanzenverbreitung des Carpathiens,' by Dr. Clements; 'A discussion of Kuntze's *Revisio generum plantarum, III<sup>II</sup>*,' by Dr. Pound.

It was agreed that the last paper should be prepared for early publication.

THE ACADEMY OF SCIENCE OF ST. LOUIS.

At the meeting of the Academy of Science of St. Louis on the evening of October 17, 1898, Mr. C. H. Thompson spoke of some interesting stylar movements of certain Marantaceæ, connected with their pollination.

Seven persons were proposed for active membership in the Academy.

At the meeting of the Academy on the evening of November 7, 1898, Mr. James A. Seddon, of the Missouri River Commission, presented a paper on 'Resistance to Flow in Hydraulics,' in which the point was made that relatively a small part of this resistance, so far as open streams were concerned, was directly attributable to friction against the bottom and limiting banks, but that the resistance was found acting between accelerations and impacts and showed in forced distortions of the free surface, from which forms the energy passed into internal motion.

Seven persons were elected to active membership in the Academy.

WILLIAM TRELEASE,  
Recording Secretary.

ALABAMA INDUSTRIAL AND SCIENTIFIC SOCIETY.

The regular fall meeting of this Society was held in Birmingham, November 8, 1898, Professor M. C. Wilson, of Florence, President, presiding. About fifteen members and others

were present. The Secretary read the report of a committee appointed for the purpose of considering the matter of recommending legislation to secure full returns of mineral statistics. In this report it was recommended that the Society ask the Legislature to amend the State mining laws so as to require the operators and lessees of mines, quarries, furnaces, coke works, clay beds and industries based on clay to make monthly returns of their production to the State Mine Inspector, and at the end of the year an annual report of the same. This course, it is thought, would be most likely to secure full and accurate returns. The Society then adopted resolutions requesting the Governor to urge upon the Legislature the importance of making appropriation for the purpose of securing representation for the State at the coming Paris Exposition, and also of memorializing Congress to take suitable steps for bringing about a change in the present French tariff laws so far as regards American iron.

There were no formal papers presented at this meeting, but steps were taken to secure articles at future meetings by assigning definite subjects to members. Seven new members were elected, after which the Society adjourned until the annual meeting in January, at which time there will be an election of officers for the ensuing year.

EUGENE A. SMITH,  
Secretary,

NEW BOOKS.

*Food and Feeding.* SIR HENRY THOMPSON. London and New York, Frederick Warne & Co. 1898. Ninth Edition, enlarged and revised. Pp. 312. \$1.75.

*Bush Fruits.* FRED. W. CARD. New York and London, The Macmillan Co. 1898. Pp. xii+537. \$1.50.

*Nature Study for Grammar Grades.* WILBUR S. JACKMAN. Danville, Ill., Illinois Printing Co. 1898. Pp. 407.

*Répertoire bibliographique des principales revues française pour l'année, 1897.* DR. JORDELL. Paris, Per Lamm (Librarie Nilsson); New York, Lemcke & Buechner. 1898. Pp. 209.

# SCIENCE

EDITORIAL COMMITTEE: S. NEWCOMB, Mathematics; R. S. WOODWARD, Mechanics; E. C. PICKERING, Astronomy; T. C. MENDENHALL, Physics; R. H. THURSTON, Engineering; IRA REMSEN, Chemistry; J. LE CONTE, Geology; W. M. DAVIS, Physiography; O. C. MARSH, Palaeontology; W. K. BROOKS, C. HART MERRIAM, Zoology; S. H. SCUDDER, Entomology; C. E. BESSEY, N. L. BRITTON, Botany; HENRY F. OSBORN, General Biology; C. S. MINOT, Embryology, Histology; H. P. BOWDITCH, Physiology; J. S. BILLINGS, Hygiene; J. MCKEEN CATTELL, Psychology; DANIEL G. BRINTON, J. W. POWELL, Anthropology.

FRIDAY, NOVEMBER 25, 1898.

PROGRESS IN PHYSICAL CHEMISTRY.\*

## CONTENTS:

<i>Progress in Physical Chemistry: PROFESSOR THEODORE W. RICHARDS.....</i>	721
<i>A Century of Personal Equations: PROFESSOR TRUMAN HENRY SAFFORD.....</i>	727
<i>Some Dangers of the Abuse of Chemical Formulas: PROFESSOR F. P. VENABLE.....</i>	732
<i>The Vetterli Escarpments of Southern Sweden: J. EDMUND WOODMAN.....</i>	735
<i>Life Conditions of the Oyster: Normal and Abnormal.....</i>	736
<i>Notes on Inorganic Chemistry: J. L. H.....</i>	740
<i>Current Notes on Anthropology:—</i>	
<i>Egyptian Origins; Yucatecan Ruins; Slavic Antiquities; Ancient Labor Unions: PROFESSOR D. G. BRINTON.....</i>	741
<i>Scientific Notes and News:—</i>	
<i>Bulletin of the U. S. Geological Survey descriptive of the Educational Series of Rock Specimens: W. F. M. The German Deep-sea Expedition; General.....</i>	742
<i>University and Educational News.....</i>	748
<i>Discussion and Correspondence:—</i>	
<i>Measurements of Precision: PROFESSOR A. G. WEBSTER. A Trip to the Tertiary Formations of Wyoming and Colorado: S. WARD LOPER. The Proposed Catalogue of Scientific Literature: ALFRED TUCKERMAN.....</i>	749
<i>Scientific Literature:—</i>	
<i>Paulton on Charles Darwin and the Theory of Natural Selection: PROFESSOR A. S. PACKARD. Delage on La structure du protoplasma: PROFESSOR CHARLES S. MINOT. Venable and Hove's Inorganic Chemistry according to the Periodic Law: E. R. Worcester on The Philippine Islands and their People: PROFESSOR WILLIAM LIBBEY. General.....</i>	752
<i>Scientific Journals.....</i>	758
<i>Societies and Academies:—</i>	
<i>The National Academy of Sciences. The New York Section of the American Chemical Society: DR. DURAND WOODMAN. Chemical Society of Washington: WILLIAM H. KRUG. Students' Geological Club and Conference of Harvard University: J. M. BOUTWELL.....</i>	758
<i>New Books.....</i>	760

In these days of far-reaching specialization the would-be speaker upon any subject is between a new Scylla and a new Charybdis. In order that his production should be comprehensible to those outside of the specialty it must almost inevitably be made boresome to those within the fold; but, on the other hand, that which is new to the specialist in his own topic is apt to be quite too new to the layman. Either popularizing or specializing is likely to wreck the speaker's purpose by inducing at least a part of his audience to slumber, and this danger is especially imminent after dinner on a hot day which has been filled with mental effort. In this brief address, which Professor Smith has entrusted to my care, I shall probably run foul of both obstructions; but this irregular course will have the great concomitant advantage of permitting each class of hearers to obtain a few minutes of much needed repose.

We are rather accustomed to look upon physical chemistry as being a very modern invention, and in one sense we are not wrong in so doing. But after all, many of the fundamental generalizations of physical chemistry are by no means recent, and some of them are really old. Leaving out of account the probable discoveries in the

\* Address before Section C—Chemistry—of the American Association for the Advancement of Science, August, 1898.

subject made by Adam and Eve in the Garden of Eden, it is certain that the philosophers and alchemists were as much interested in those phenomena which lie on the border-line between physics and chemistry as in those which were purely physical or chemical. Indeed, the sharp line between the two subjects, drawn with so much emphasis twenty or thirty years ago, did not then exist. It is interesting to note that this sharp line is now rapidly being erased; we are realizing more and more that the laws which govern one class of phenomena are applicable also to the other. Thus the cosmic working of the mind of man swings back and forth; will it ever come to rest upon the absolute truth?

In the middle of the seventeenth century, while this country was in an infantile condition, and Harvard College was little more than embryonic, Robert Boyle discovered his law relating to the contraction of gases under pressure—one of our most fundamental conceptions to-day. Lavoisier, before his tragic death in the Reign of Terror, forced upon a somewhat reluctant world the idea of the conservation of mass—an idea which perhaps had been half assumed by some before—and in so doing laid a corner-stone of the great structure which was to follow. Only a few years later, Dalton, Avogadro, Ampère, Gay-Lussac, Dulong and Petit, Davy and Faraday, that prince of pioneers, with others less famous, made great additions to the world's thought in a physico-chemical direction. As far back as our forties Julius Robert Mayer and Helmholtz had acquired a clear grasp of the conservation of energy, while the other great law of energy had been partially realized by Sadi-Carnot two decades before. Hittorf's classical research on electrolytic conductivity, and Wilhelmy's epoch-making study of the speed of a reaction, a research upon the lines laid down by Wenzel and Berthollet so much earlier,

took place over forty years ago. Only a decade later Guldberg and Waage laid down, in unequivocal and comprehensive terms, the fundamental law of mass-action, which is the basis of Wenzel's, Berthollet's and Wilhelmy's observations, as well as of the progress and equilibrium of every other chemical change.

Why, then, with these foundations laid so far in the past, are we inclined to call physical chemistry a brand-new structure?

We all know that a part at least of the retarded development was due to the difficulty of dealing with solutions, which seemed anomalous in so many ways. Van't Hoff, by showing that a substance in solution followed many of the laws which would govern it in the æriform state, and Arrhenius, by explaining, in a simple way, the differences between solutions conducting electricity and those which are non-conductors, cleared the track of these obstructions; hence, for the last ten years the pace has been rapid. But it seems to me that there is another reason for the tardiness of the recognition of the importance of physical chemistry to be found in an unfortunate tendency observable sometimes in both chemists and physicists, a tendency which I am afraid we must call prejudice. Not only have untenable theories been held long after their time, but whole fields of study have been neglected by most chemists and physicists, because they lie on the border-line between the two sciences.

The average physicist only half realized that one of the most important relations of his great new force, electricity, is chemical, while the chemist does not always realize, even to this day, that Wheatstone's bridge and the telephone are chemical tools just as legitimate as, and no more 'physical' than the thermometer, or the time-honored balance, which extricated his predecessors from so hopeless a slough a hundred years ago. The day is fast approaching, however, when



both chemist and physicist will welcome every mode of acquiring more light upon the absorbing topic which engages them in common—the study of the ultimate laws and structure of the universe.

It is a pleasure to think that one of the foremost of the brilliant men who have joined in advancing this wished-for end—this union of the resources of physics and chemistry to a common purpose—since the last meeting of the American Association has had his services recognized and his opportunity enlarged by his own University of Leipzig. Wilhelm Ostwald's new laboratory for physico-chemical research is the second important university building for this purpose which has been erected in Germany, the first having been built at Göttingen for the brilliant Walther Nernst; and the fact that Ostwald should at last have obtained a material outfit worthy of his unusual mental equipment is welcomed with enthusiasm by his many warm friends. We all know what a profound effect Ostwald's surprising book, his timely *Zeitschrift*, and in general his broad and progressive point of view, have had upon the development of both chemistry and physics, and it has been a matter of some surprise to many that so great an influence should have emanated from a laboratory so insignificant as the old *Zweitem Laboratorium*, so called. The new building, although not very large, is in many respects a model; the architect and director of any kind of scientific workshop could not fail to obtain valuable hints from the detailed statement of it contained in the recently published appendix to the *Zeitschrift für physikalische Chemie*. What a pity that America should allow Germany to outstrip us so far in devotion to the ideals of pure science! How long will it be before we build laboratories especially for physical chemistry, or even in many colleges allot a considerable share of old buildings to this

end? And yet this physical chemistry now comprehends all of the field of theoretical chemistry, except a certain kind of reasoning concerned with the structure of organic substances, and the purely chemical part of the mysterious classification called the periodic system of the elements.

Very few of the processes of nature are simple in their proximate causes or their outward manifestations, however simple the grand underlying principles may be in their ultimate essence. The old maxim, by which theories were so often consciously or unconsciously judged, 'Our theory is so simple that it must be true,' is a dangerous guide. Geber's old notion that the whole world consists of sulphur and mercury, and the topsy-turvy delusion of phlogiston, relied largely on this maxim for support, and it behooves us to avoid similar mistakes. When the ancient idea of luck had been eliminated from scientific reasonings mankind admitted that every phenomenon is a function of its controlling causes; but that all the mathematical relations should be capable of solution, although to be sure only with the aid of the potent modern methods, is a new conception. In the old days problems in chemistry which could not be solved by simple arithmetic, or at best by elementary algebra, were considered incapable of quantitative solution; now, the higher mathematics is a facile tool in the hands of many an eager chemist. Even that mystery of mysteries, the smallness of the yield in the preparation of organic substances, has a flood of light shed upon it by the phase-rule and the mass-law!

No one who is familiar with the facts can doubt that the mathematical point of view will prove in the future more and more useful to chemists, as well as to the new physical hotanists and zoologists, who are bringing it to bear on their transcendently recondite problems. These last-named investigators will follow in the footsteps of

chemists, as chemists have followed in the footsteps of physicists.

The advance of the mathematical point of view in chemistry has brought with it an entirely new danger, as well as a new field of power. The accuracy of a result, of course, depends upon the accuracy of the foundation upon which the reasoning rests; and accurate mathematical processes may lead to wholly erroneous conclusions if they are based upon incomplete data. In chemistry this cause of error is especially prominent, because of the great complexity of most of the phenomena and the fact that they are often modified by subordinate influences. For this reason a physicist, used to simple phenomena and less complex effects, is especially apt, when he deals with problems allied to chemistry, to erect a large superstructure of mathematical reasoning possessing the semblance of reality upon a paper foundation, and be dreadfully awakened some fine day by the collapse of his air castle. The only mode of guarding against this subtle cause of disaster is to bring as much skill into every step of the experimentation as into the pure reasoning based upon the supposed facts. Here the physicist is seriously hampered by his lack of knowledge of chemistry, as well as by his usual repugnance to dealing with glass vessels and liquids; while, on the other hand, the chemist is equally hampered by his inbred dislike of brass instruments and his imperfect acquaintance with the manipulation of his new sensitive tools.

In short, one must be an accomplished chemist, physicist and mathematician in order to attain the highest results in modern theoretical chemistry, and the number of men who have the time or ability to acquire this threefold education can never be large. All honor to van't Hoff, Ostwald, Nernst and the others who come nearest the high ideal! While it is true, however, that few men can hope to attain

the highest, it does not follow that the rest of us cannot be of great use. Each man can be of value in his own particular sphere; it is only necessary that he should work faithfully with a single eye to the truth, that he should be as free as possible from prejudice, and that his published work should be as accurate as he can make it. A well conducted organic synthesis, a few carefully determined solubilities, will in the end be more valuable to the progress of science than a false generalization, no matter how ingenious the latter may be. But how great is the responsibility of the collector of facts! for if his observations are false his work is of less value even than that of the false theorist; it has not even ingenuity in its favor, and is worse than useless. Ostwald has more than once pointed to the responsibility attending publication, and we should all do well to heed his warning.

A comprehensive design which I had once harbored of giving you a *résumé* of the year's work in physico-chemical research throughout the world has been relinquished because of the great number of small papers which could not be treated satisfactorily in the brief space of an evening's talk. The subject of stoichiometry, in Ostwald's rather comprehensive interpretation of this word, has received this year the attention usually accorded to it. Solutions have still occupied many able men, without having by any means had their possibilities exhausted. Van't Hoff's admirable little book upon double salts has already begun to exercise an effect upon the chemical world which the scattered and less illuminating papers of his students could not have been expected to exercise. Dr. Gibbs' interesting address upon this important topic will undoubtedly excite further study on the whole question of the so-called 'molecular compounds,' which are so little understood and so hard to reconcile with our only partially satisfactory ideas of quantivalence. The

far-reaching subject of chemical equilibrium is receiving more and more attention every year. There has been great activity in the fascinating field of electrochemistry, and it is pleasing to see that some of the fundamental notions of this new science are coming to be recognized by the analyst and the technical chemist. Not least among the startling events of the year had been the supposed discovery of a number of new elements, crypton, neon, metargon, coronium and etherion; if these really exist, we have here a series of brilliant chemical discoveries made solely by means of physical instruments and operations.

The most important of these interesting investigations are undoubtedly as well known to you as to your speaker, for in this day the sources of information are equally open to all; hence it would be a work of supererogation for me to discourse upon them in detail, even if there were time to do so. I prefer, therefore, to call your attention to some unpublished work with which you can hardly be so familiar; I mean the physico-chemical problems which have enlivened the last winter's laboratory work at Harvard. Since these covered a somewhat extensive field their exposition may serve the double purpose of illustration and information. It is a pleasure to state that most of these researches would not have been thought of without the inspiring example and precept of the great men of whom I have spoken. The host of interesting investigations thus prompted in all civilized lands afford the best possible proof of the value of the modern physico-chemical hypotheses.

Dr. Gordon, the Harvard assistant in physical chemistry, has finished a very interesting series of measurements of the potentials of galvanic cells composed of metallic plates immersed in fused salts at high temperatures. After overcoming experimental difficulties, too numerous to mention,

he succeeded in obtaining constant values which agree remarkably with Nernst's formula and throw interesting light on the degree of dissociation existing in fused salts.

Mr. Edward Collins has nearly finished an elaborate attempt to verify Faraday's law with rigid exactness, an attempt which has met with greater success than any previous one.

Mr. G. N. Lewis made a series of careful measurements of the change of the potential of numerous reversible electrodes with the temperature, as well as a comprehensive revision of Meyer's inaccurate work on concentration cells involving amalgams of different strengths. In the thermodynamic discussion of the results Mr. Lewis arrived at some very interesting conclusions concerning strong as well as weak solutions of metal in mercury, and extended his experiment and mathematical analysis to the consideration of the potential of the unamalgamated metal in a solution of one of its salts. It is needless to say that this question is one of wide significance, but lack of time prevents my doing more than call attention to it now. Mr. Lewis's preliminary paper will appear early in the fall.

Mr. F. R. Fraprie spent much time in studying the eccentricities of inversion temperatures and transition intervals exhibited by the double sulphates of potassium and manganese. This problem proved to be far more complex and interesting than the similar case involving magnesium instead of manganese, a case which has been so carefully investigated under Van't Hoff's supervision. While Mr. Fraprie was not able to push the matter to completion he obtained data enough to enable one to plot many of the most essential curves and to draw a mental sketch of the situation. It is hoped that this work may be continued during the present year.

Mr. Faber, in the course of a research having a more practical end as its chief



aim, made a series of determinations of the solubilities of argentic halides in solutions of sodic thiosulphate, and obtained data which may be of use in determining the mechanism of this reaction. Messrs. Harrington and Henderson made a few interesting observations on some cases in which the dissolving of a solid in a solution caused a lowering instead of a rise in the boiling point, and Mr. Churchill made a careful determination of the melting point of crystallized Glauber's salt. The aim of this last labor was to secure a new fixed point for the standardizing of thermometers, and we succeeded in showing that the point was as easily obtained and as constant at  $32.484^{\circ}$  as could be desired. This means of verifying thermometers will be a great boon to those who have not a standard instrument at hand. The paper will appear in the September numbers of the *Zeitschrift für physikalische Chemie* and the *American Journal of Science*.

Besides these varied researches, a protracted study of the causes of the occlusion, and the unequal release of gases by the oxides of metals formed from the nitrates, occupied most of my spare time. It became evident that the excess of oxygen usually present in such material has a tendency to work its way out by a process of dissociation and recombination which reminds one of the old-fashioned explanation of electrolysis. The nitrogen, not being able to escape in this fashion, is retained. This paper has just appeared in the Proceedings of the American Academy.

In addition to these, several other researches were also in progress, which, although they belong strictly to the domain of inorganic chemistry, would never have been undertaken but for the theoretical interests involved. Prominent among these were the revisions of the atomic weights of cobalt, nickel, uranium, strontium and calcium, undertaken by Dr. Cushman, Messrs. Baxter and Merigold, and myself.

Of course, it sometimes happens that physico-chemical problems involving the use of complicated apparatus may be more readily solved in a physical than in a chemical laboratory, and in any case the cooperation of these two departments is highly advisable. I am happy to say that Dr. Duane and others have been conducting such chemico-physical investigations at the Jefferson Physical Laboratory of Harvard College, but of these I have no authority to speak.

When one has been discussing the past and present progress of any subject it is natural that the mind should turn to the future also. What fields are likely to prove the most fruitful in the years to come? What researches will probably best advance the interests of science and, therefore, of the life of man? Prophecy is always an uncertain business, but if one recognizes the uncertainty it has few dangers and becomes at least amusing. In this case, however, it presents few difficulties.

The whole field of physical chemistry is so fruitful when treated by modern methods that one can hardly single out any section as especially unpromising. Almost every subject is worthy of research; a more important question is the *spirit* in which the research is to be undertaken.

There have always been two parties as regards any question brought forward by mankind for discussion—the conservative party and the radical party. The former has a tendency to cling to old ideas simply because they are old, and the latter has a tendency to adopt new ideas simply because they are new. It seems to me that neither of these tendencies is legitimate. One should seek new points of view continually, but he should hold to that which is good until something is proposed which seems to him better. In every case he should weigh the respective arguments for and against

the new point of view with a mind as free as possible from prejudice, and with a single eye to the truth. In short, the ideal investigator is the scientific independent, the chemical 'mugwump.' It is too unreasonable to hope that the problems of the twentieth century will be dealt with in this thoughtful but untrammelled fashion?

We Americans rejoice in having on our side of the ocean the world-renowned names of several great men, of Wolcott and Willard Gibbs, of James Crafts, Edward Morley, the late Josiah Parsons Cooke and others, who have combined chemistry with physics and mathematics; but, nevertheless, one must admit that America has not done as much as one could wish toward building up the fabric of modern physical chemistry. Although science is world-wide, and scientific men should be cosmopolitan, the existence of this Association proves that there is a patriotic side to the matter too. While welcoming the truth, wherever it is discovered, let us then do all we can to further its emanation from American laboratories and writing desks.

THEODORE W. RICHARDS.

HARVARD UNIVERSITY.

#### A CENTURY OF PERSONAL EQUATIONS.\*

IN 1795 Maskelyne, Astronomer Royal at Greenwich, discovered that his assistant, Kinnebrook, was in the habit of noting star transits about seven-tenths of a second of time later than himself, and discharged the poor fellow as 'vicious' in his method of observing. The matter attracted little attention until, about twenty-five years later, the celebrated Bessel investigated it, and showed that the best observers whom he could influence exhibited similar discrepancies in their transits. Bessel himself was exceptionally early in his times, and found that other astronomers were usually

later. The theory which he formed was that the early observers, Maskelyne and Bessel himself, heard their clock beats before they saw the stars' images, while the late observers, Kinnebrook, Argelander, W. Struve and others, saw first and then heard. The theory of Bessel has been generally adopted by astronomers and psychologists, and the investigation of the differences between astronomers has been pursued pretty continuously since 1836, when Airy, as Astronomer Royal at Greenwich, began a regular continuance of Bessel's investigation soon after entering upon that office. The matter was more or less perplexing to the Greenwich observers for the twenty years between 1836 and 1855. In 1853 the so-called eye-and-ear method, which had been employed for about a century previously, was laid aside at Greenwich for most purposes, and replaced by the American, or chronographic, method of galvanic registration, invented by Sears Cook Walker in 1849.

During the first half of the century, 1795 to 1895, to which this paper refers, observations of transits were made by Bradley's method, or by eye and ear, but for the second half century observers have had the benefit of Walker's invention, and of the ingenious apparatus constructed by the Bonds and other mechanicians for the purpose of carrying out the principle introduced by Walker. The investigations of personal equation up to 1853 are based, then, upon experimental psychology as developed by Bessel, and have led to a pretty complete body of empirical facts in that direction. But Bessel and his associates considered the whole matter enigmatical and difficult to trace, owing to the fact that the phenomena are subconscious and not easy to bring under the laws of experimental science. Observers noted large differences in their times, a second or more, and could not reduce them to moderate

\* See also my article in SCIENCE for Nov. 26, 1897.

amounts by long practice. A second of time in longitude amounts to fifteen hundred feet on the map if the place be near the equator, so that, all told, the elimination of personal equation is one of the most important and perplexing problems of practical astronomy.

The matter became more easily handled on the introduction of the chronograph in 1849, for several reasons. In the first place, the Greenwich observers found that by the new method the personal equations were diminished in amount in a general way. Sir George Airy, in his report for 1854, sums the matter up in these words:

"This apparatus, the chronographic, is troublesome in use, consuming much time in the galvanic preparation, the preparation of the paper, and the translation of the puncture indications into figures." And in his report for 1855 he also says: "The magnitude of the personal equation in the galvanic-touch method is not above half of that in the eye-and-ear method." But among the observers who use it there is but one opinion on its astronomical merits, that in freedom from personal equation and in general accuracy it is very far superior to observations by eye-and-ear method. This judgment of Airy's, however, needs some slight modification, according to the opinions of many of the best practical astronomers now living, and it is worth while to look at the other side in order to see if the eye-and-ear method should be kept up in active practice. First of all, as a method of training young observers it has some importance, as the apparatus is greatly simplified if the galvanic connections and preparation are eliminated. It is also often necessary to make time observations at so great a distance from civilization that the delicate chronograph is better left behind. This is a practical difficulty I have often experienced in geographical work in New Mexico and other

distant portions of the United States; no chronograph was furnished me, and it was possible to fix the position of a corner post of Wyoming without a chronograph with an accuracy quite unusual in the U. S. Land Office at that time. Similar considerations were of importance in the geographical mapping work of the U. S. engineers, where the so-called station error or irregularities in the surface of the geoid far exceeded any errors arising from the use of the eye-and-ear method. After the great Chicago conflagration of 1871 it was a piece of good fortune that I could use the eye-and-ear method, as I was engaged in geographical operations for the U. S. engineers, who did not then possess a sufficiently complete supply of chronographs. In 1868 began the observations of the great international star catalogue of the *Astronomische Gesellschaft*, which is now approaching completion after thirty years of steady observation. At that time the Council of the Society were undecided as to the use of the chronograph in their catalogue, and its use or non-use was left to the discretion of the observers. In my own case I decided to begin without one, as the Chicago Observatory, where I then was, had not provided money for it, and the chronograph now used by my friend, Professor Hough, at his new observatory at Evanston, was constructed later. The conflagration, in its consequences, put an end to my work upon a zone of the A. G. C., and the zone continued at Lund, Sweden, by an appropriation from the Swedish government, and is, I suppose, nearly completed; but I went far enough, by the eye-and-ear method, to satisfy myself that it would have been entirely practicable to go on and satisfy the requirements of the Council as regards accuracy. At Harvard College Observatory my lamented friend, Professor W. A. Rogers, used an excellent Bond chrono-



graph, and completed his zone about a dozen years ago. Other observers decided for themselves whether or not to employ the chronograph, with the general result that with it the zone would be rather more accurate on the surface, and without it would be rather more promptly completed. When I say rather more accurate on the surface I mean that chronographic registration appears to be especially liable to a peculiar form of personal equation, viz.: a variation of the time of transit and, consequently, of the resulting right ascension, when the star is fainter than the ordinary stars observed for clock correction. This matter was pointed out originally as essential to be investigated, but has not yet been fully cleared up. So far as chronographic observations are concerned, there seems to be no doubt that the effect of faintness upon the time of transit is to delay the reaction or registration very generally, if not absolutely without exception. But, on the other hand, there are several observers, Argelander, Bauschinger, Deichmüller, Copeland and Börgen, for whom stars near, but below the limit of easy observation, with the instrument employed, are observed by Bradley's method earlier than brighter stars, while the same observers note the transit of stars near this limit, but above it, quite normally. This feature of his own observations was detected by Argelander himself, and confirmed by Auwers in his careful discussion of his own Berlin zone, in which the Bonn observations are taken into account.

As the phenomenon detected by Argelander in his own observations was referred to a psychical cause, it is likely that other observers might become aware of a similar phenomenon in their own observations, if it were not that the differences are trifling and liable to mislead the investigator who shall attempt to reproduce them, as is sufficiently apparent when the attempt is made

to introduce a strict logical order into the statements already published.

Personal equation is a subject so different in its causes from the ordinary instrumental peculiarities which manifest themselves in results that the causes of it, which are psychical, are entirely liable to be mistaken and thus obscured, and entirely trustworthy results are liable to be rejected as abnormal, because they do not agree with groundless hypotheses. Suspicion has been expressed, for example, that Nyrén's latitude observations, with the prime vertical transit of the Pulkova Observatory, are liable to an equation of a personal nature depending upon the magnitude of the star observed. The suspicion was based upon the theory that the chronographic and eye-and-ear methods have some elements in common, which rendered them equally liable to such a form of personal equation, while the fact is that the general phenomena of personal equation by eye and ear are due to the cause detected by Bessel, viz.: the 'Zeitverschiebung,' or displacement of time, which arises when the attempt is made to add an impression on the sense of hearing to one at exactly the same instant on the sense of sight. In the chronographic method of registration the time required is in normal instances positive—that is, the 'reaction' time of the psychologists. The two methods of observing transits are psychically different, and the general result for ordinary time stars is that the average chronographic observer produces transits about as much later than the average eye-and-ear observer as is required for a simple reaction. The amount is 0.162 at Greenwich for the ten years 1885 to 1890, inclusive, and 1890 to 1894, inclusive, with trifling fluctuations (see my paper in No. 425 of the *Astronomical Journal*). Since writing that I have received the introduction to the Greenwich Astronomical Observations for the year 1895, which gives a result almost identical with the years from

1885 on; for 1895 we find  $e' - e = 0^{\circ}.161$  for 13 observers in all. The difference  $-0^{\circ}.001$  between the mean for ten years and that for the single year 1895 is far less than the probable error about  $\pm 0^{\circ}.002$  of the mean for 1895, a decided indication that the quantity  $0^{\circ}.16$  is obtained with substantial accuracy from the ten years' results, and represents something which arises from a true cause or combination of true causes. A persistent positive sign of the quantities  $e' - e$  is due, as it seems, to the fact that the chronographic transits are registered too late, combined with the other fact that the eye-and-ear observations are for some observers too late and for other observers too early. In order, then, to obtain the true time of a series of transits, the chronographic method, if employed by all the Greenwich observers, would give an average time too late by about  $0^{\circ}.16$ , while the eye-and-ear method would give an average time  $0^{\circ}.16$  earlier and more nearly correct. We may suppose, for example, that in 1895 the 13 observers whose eye-and-ear personal equations are discussed in the introduction for that year have observed each a star of the average magnitude of a Greenwich time star, and in a moderate declination near the average declination of time stars, and, reducing the observations in the usual way, have obtained a clock correction by each method, but without the application of the personal equation. The average of the thirteen chronographic clock corrections would then be  $0^{\circ}.16$  too small, while that of the thirteen eye-and-ear clock corrections have no common error constant for the thirteen. The standard observer for 1895, Mr. Lewis, obtained by eye and ear a clock correction  $0^{\circ}.10$  larger than by chronographic on three nights in that year, and hence, so far as these three nights show, his eye-and-ear transits are more nearly correct than his average chronographic clock corrections, as we cannot well infer

that the actual reaction time occupied in the bisection is very far from  $0^{\circ}.16$ . For a series of ten years in all the two-method equation for Mr. Lewis has been  $0^{\circ}.139$  in the mean or for separate years as follows :

1885 + 0.06
1886 + 0.13
1887 + 0.13
1888 + 0.19
1889 + 0.15
1890 + 0.15
1891 + 0.09
1892 + 0.19
1893 + 0.20
1895 + 0.10

No eye-and-ear observations were recorded for Mr. Lewis in 1894, and the largest difference from the mean, viz. :  $-0.079$  for 1885, is not as large as the corresponding difference  $-0.089$  for the chief assistant, Mr. (now Professor) Turner, for the same year. The probable error of a year's determination for Mr. Lewis is  $\pm 0^{\circ}.033$  by the sum  $0^{\circ}.37$  of the ten differences from  $\pm 0^{\circ}.031$ , and by sum of squares the mean error is  $\pm 0.047$  and the probable error  $\pm 0^{\circ}.031$ . The important question whether there is in general a variation of personal equation with magnitude has already been tested in a good many ways by various astronomers, with the general result that such variations are far more uniformly exhibited in chronographic transits than in those taken by eye and ear. The investigations of the effect of such a personal equation have been carried on for the following zones of the Catalog der Astronomischen Gesellschaft, already published :

Zone	PLACE	OBSERVER
1° to 5°	Albany	Boss
15° to 20°	Berlin	Auwers
20° to 25°	Berlin	Becker.

There are various other investigations for chronographic observers which all agree in general with the result of the reaction

experiments in psychological laboratories, viz. : that the time of reaction, like that of chronographic registration, is lengthened when the impression on the sense is faint. But for eye-and-ear transits the experiments with screens are so far few and somewhat indecisive, and the phenomenon detected by Argelander, viz.: an anticipation of the transit of a star faint enough to be a little difficult of observation, has been noticed by several observers and tested in various ways.

The suspicion is expressed in Number 369 of the *Astronomical Journal* that the variation of personal equations with the magnitude of the star observed affects equally eye-and-ear observations and those made with the chronograph.

But on reading over the article in question it is at once noticed that there is great lack of detail in the result quoted, and that the direct determination by Becker shows an anomaly which the author of the article in *Astronomical Journal* No. 369 is confessedly unable to account for. A careful reading of Becker's investigation in his Berlin zone shows that the observations were made with Professor Becker's well-known skill and care, and whatever difficulty there may be in reconciling these results with other observations is probably due to the treatment of the latter, and hence that the lacking details in *Astronomical Journal* No. 369 would, if supplied, perhaps account for the discrepancy.

The author of the article quoted has not, so far as it appears, used his conclusions in his later important investigations. Even his rather hasty decision in favor of such a variability of eye-and-ear personal equation with magnitude deserves careful study as to the facts involved.

I venture to suggest a line of observation which I desire to see carried out, and which will add to the certainty of these conclusions.

The Christiana zone  $64^{\circ} 50'$  to  $70^{\circ} 10'$  of the A. G. C. has been long completed by the late Professor Fearnley, by whom the transit observations were made by eye and ear, and his successor, Professor Geelmuyden, who made the observations for declination and most of the reductions. The observations for right ascension are liable to but small casual errors, and have, I believe, been shown to be nearly free from constant error due to the faintness of the stars below the magnitude at which they are easily observable. The stars of this zone below a certain magnitude, for which I may assume 8.2 of the B. D. scale, might be reobserved to some advantage in connection with a similar reobservation of Groombridge's stars, which is now going on at Greenwich. In order to conduct such reobservation to the best advantage, all things considered, I should confine it to those stars in Groombridge's catalogue which are within  $25^{\circ}$  of the pole for the epoch 1875, as the meridian circle in my charge has an aperture of four and one-half Paris inches, and there are very few of Groombridge's stars which it cannot easily reach, as I know by long experience with it. The few Groombridge stars, if there are any such, which would give any trouble with the Williams College circle to reobserve, are those which Groombridge picked up on exceptionally clear nights, but they are included in the Radcliffe Catalogue, whose right ascensions were observed with an aperture of considerably less diameter. The cases will be very few in which Groombridge's stars will not be easily observed on any good night with the aperture of 122 mm., and in which the observer would be liable to the 'Argelander phenomenon' or reversal of the ordinary order of sensations as shown in the cases of Argelander himself, Copeland, Börgen, Bauschinger and other good observers.

The difficulty of separating this form of



personal equation from other forms is very considerable. When the Greenwich catalogue for 1890 is published, it will be necessary to find out in some manner the personal error depending on magnitude of the chronographic right ascensions of that catalogue, but these will have in them a personal element depending on the habits of the observers by whom the transits have been registered, and this will be complicated unless it is shown that the various observers have been brought to a more uniform habit than is generally supposed. The comparison of the catalogue for 1890 with the zones of the A. G. C. will at a later time furnish a great amount of interesting information, but which at present needs the careful study of the methods of observation and elements of reduction which have been employed in the zones already observed by eye and ear as well as by chronograph.

The catalogue of Dr. Romberg\* is the best standard of comparison for the A. G. C. eye-and-ear zones, as it was observed in the years 1874 to 1880 with a powerful meridian circle whose aperture was large enough to render all the A. G. C. stars distinctly visible, and the standard of reduction is the same as for the A. G. C., viz.: Wagner's right ascensions for 1865 and Nyrén's declinations for the same epoch.

TRUMAN HENRY SAFFORD.

WILLIAMS COLLEGE.

*SOME DANGERS OF THE ABUSE OF CHEMICAL FORMULAS.*

WHEN Thomson made his memorable visit to Dalton, in Manchester, nearly one hundred years ago, and was shown the system of symbols by which Dalton hoped to make clear his ideas as to atoms and their combinations, he was enthusiastic as to the future usefulness of such a system. And, although the system was clumsy and inad-

quate to the task of properly representing the great mass of chemical facts, it contained the valuable idea of graphic representation which was to be ingeniously elaborated and developed by later masters of the science.

It was through Berzelius next that chemical symbols were made simpler and clearer. So manifest was their usefulness that they speedily claimed the additional advantage of almost universal acceptance. Local adoption only, the use by chemists of one nationality or the followers of one master would have proved a most serious bar to the advancement of the science. We can fancy the confusion which would arise from the use of different systems at present, but, happily, such a picture exists in the imagination only. The science has one universal language of symbols which those of every tongue can read and understand. The advantages of such a system need not be dwelt upon. I purpose rather pointing out a few possible dangers and abuses.

The simple application of symbols in the time of Berzelius has become more complicated as the science has developed and the knowledge of both composition and constitution of chemical bodies has increased. Intended at first to represent elements and single compounds, the symbols have been developed into complex formulas, and these have been united into algebraic equations in the effort to make them represent as much as possible of the knowledge so laboriously acquired by multiplied experiments. The system has become in truth the shorthand of chemistry.

While its great usefulness is not to be underestimated, the limitations of the system should be duly recognized. In the first place, it can only partially represent the mathematical relations of the science. Again, there is no mode of indicating in an equation the physical forces which always accompany chemical reactions. These re-

\* I regret to say that this excellent observer has passed away since these words were written.

lations are of especial importance and yet there is no adequate mode of expressing them. It is questionable how far such important relations as the electro-chemical and those of chemical affinity itself can be deciphered from those equations. Certain it is that the best constructed equation frequently represents only one of many reactions occurring at the same time and under the same conditions, and there is no way of indicating under what conditions the given equation is true. It often happens, especially in organic chemistry, that an equation upon which much stress is laid is really a secondary and subordinate one, and since this is not indicated by the formula the student may be misled.

Such questions as whether all of these more or less desirable matters can ever be represented by any system, or whether the present system is not the most perfect which we can hope for, do not come within the scope of the present discussion. It is sufficient to point out that the system is not flawless. We must all acknowledge that it is indispensable to chemists and, being something more than a mere shorthand system, greatly aids him in his work.

For these reasons all young chemists must be properly initiated and inducted into the mysteries of the system so that they too may belong to the great order of the *illuminati*.

The great value of symbols and formulas in teaching chemistry is not to be questioned. Their use is essential to the imparting of a quick grasp and a clean mental picture of what takes place. But their abuse is quite possible, and I shall briefly point out some of the dangers which lie in this direction. It must be constantly borne in mind that these formulas do not constitute the science of chemistry, but are merely an abbreviated mode of stating some of the facts, while many do not admit of such concise, graphic representation. So

much stress is sometimes laid upon these symbols, and so much store set by their manipulation, that the student may gather the impression that he knows and understands much of the science when he can glibly rattle off a few of them, and he may devote much time to memorizing certain of them which it were far better to spend in an attempt at grasping the great science itself.

It has occurred to me that it might be profitable to point out the following dangers of abuse:

1st. *The Danger of Methodism.* This is a danger common to much of the elementary teaching of the day. We have of late years many schools of methods established all over the country. These have their value in so far as they tell how knowledge may be imparted in an orderly, systematic, methodical manner, but great care must be exercised lest the method should be magnified above the knowledge and the student go away with the empty method alone. I have known such schools where the whole subject was made ridiculous by extended dissertations upon the proper posture of the child in reciting or in drinking water, or some equally subordinate matter where the time at command was too valuable for more than brief mention of such details. And so we can all doubtless recall text-books on chemistry where large space is given to the arrangement, manipulation or completion of formulas and equations. Sometimes they are placed before the pupil like a dissected map or puzzle, shaken together or with some missing member to be supplied, certainly giving him one false idea, namely, that such equations are to be worked out with pencil and paper where the effort should be to impress upon him the knowledge that such equations are legitimate only when they are the result of actual experiments and when proved in every particular by direct trial. Such juggling with

formulas may induce a certain ingenuity, but may also be positively harmful so far as the acquiring of true knowledge is concerned.

2d. *The Mathematical Danger.* The effort at placing chemistry upon a mathematical basis, and so making of it a true science, according to the German definition, is a laudable one, but this end is not to be obtained by a multiplication of problems based upon the time-honored rule-of-three and the simple algebraic transformations made use of in chemical problems. Enough of this sort of mathematical work should be given to make clear the great underlying laws of chemistry—the indestructibility of matter, the constancy of proportions, etc. Beyond this harm may be done to some minds not mathematically inclined.

A bright, ingenious mind may revel in some of the abstruse and difficult problems which have been based on this rule-of-three, while other minds may be frightened and confused. There is a temptation to a bright, mathematically inclined teacher to add to these problems and exercises, but I maintain that in such case he is attempting to teach mathematics, and not chemistry.

3d. *The Mechanical Danger.* Many have seen this danger and have given forth no uncertain note of warning against it. In graphically representing formulas, especially those of organic bodies, the mechanical limitations are such that there can be no adequate picture given. Much must be left to the imagination. The effort is only to give an outline or a few points upon which to fix the mental picture. But young minds are at times so hopelessly matter-of-fact, and one of the most difficult of tasks is to transfer the vision of your imagination upon the mental retina of others. In the first place, there is the blackboard with its plain surface and white trails of chalk dust. You are endeavoring to give a picture of some collection of won-

derful symmetrical atoms bound together by strange, invisible emanations of force and endowed with marvelous properties and powers. How can you hope to do it with such means as are at your command? How can you devise mechanical means, balls, strings or rubber monstrosities which will properly aid you?

And yet, these mechanical aids are helpful, for mere word painting is far too vague for the purpose. Only beware lest the idea be given that your rubber or glass toys or scratches on the board really look like the incomparable atoms themselves, and that the chemical force displayed between them closely resembles a connecting wire or a bit of glass tubing or a streak of chalk powder.

4th. *The Danger of Idolatry.* By this I mean the placing of the formula upon the pedestal which belongs to the science itself. To my mind, next to the achievement of written language itself, the fully worked-out formula for a complex organic body represents the most wonderful accomplishment of the human mind. It is the result of years of toilsome experiment, of high theorizing and of ingenious logic. It is a building erected by some skilled artificer upon the delicate handwork of other master-workmen, all resting on the foundation stones of the science laid with infinite care and labor. It is a mighty epic to man's capacity for faithful toil, for self-sacrificing coöperation, for concentration of thought, for ingenuity of eye and hand and brain, and to his love for and deep yearning after the truth.

Yet, with all this granted as true, do not let us fall down before our formula and worship it. It is but the work of our hands after all and *humanum est errare*. The worship of that which may desert us in the time of need is apt to lead to an unfruitful and unhappy skepticism, as the history of our science during the middle decades of this century bears witness. Let us rather



be prepared to erect another more beautiful because truer building if the first should be overthrown. It is truth that we seek after, and the building of our hands can never be truth itself, but at best only its fit temple.

I trust that I shall not be misunderstood in what I have said about these dangers. I am not an iconoclast, but wish only to plead for conservatism and moderation.

F. P. VENABLE.

UNIVERSITY OF NORTH CAROLINA.

*THE VETTERN ESCARPMENTS OF SOUTHERN SWEDEN.*

To a geologist a fault is always a fault. Whatever its age, whatever the present condition of the land, he reconstructs the dislocation in his mind's eye, and sees the break as vividly as though the action were going on before him. Not so, however, some physiographers. To them a fault is expressive only in its topographic sense; and just in so far as the dislocations can be seen on the surface do many of the students recognize their existence.

On the other hand, the geologist frequently fails to note two points of some importance; at least, he often neglects them in his writings. These are the age of the dislocation, and the form assumed by the land after faulting. While in many cases some attention is paid to these, it is very noticeable that the literature of faulted regions contains little of definite statement concerning them. A good illustration of the physiographic attitude is afforded by a study of the escarpments in southern Sweden which run east from the northern end of Lake Vettern to the Baltic. On the ground, the appearance is of a tolerably steep bluff from higher land on the north down to lower ground on the south. The main escarpment is fairly continuous except near the lake, and is formed of a series of leads and offsets at high angles. The connection between them and the joint sys-

tems elaborated by Mr. J. B. Woodworth at once suggests itself, but so far only a general resemblance has been established. The various planes in these examples are more irregular in direction and continuity than in the minute cases which are the basis of Mr. Woodworth's work.

The series may be divided east and west into two parts. That about the lake and for some distance east is characterized by having the angle of the notches face southwest and the sides making the angle concave; the land is higher within the angles, *i. e.*, to the north and east. The rest of the series has angles facing southeast and the sides convex; the land is higher to the north and west. Whether this is due to any known laws cannot be shown at present. One thing is noticeable; the escarpment enters the sea on the east, but dies out on the west. It may be that this is a case of a fault dying out at both ends, and caused by some disturbance at its center; which would probably make a symmetrical figure, not alike on both sides. However, this is mere hypothesis.

To the north of the escarpments the country is a fairly even upland, peculiarly dissected and surmounted by innumerable hills which bear northwest, more westerly than any of the offsets of the escarpments. The drainage is by lakes and small streams. The former are curvilinear, and both take in general the direction of the axes of the hills. All this apparently is due to glacial action, and the same pattern exists over all the country around. In the lowland along the south side of the escarpment series there is a line of drainage from Lake Vettern on the west to the Baltic on the east. It consists of Lakes Boren and Roxen and the estuary Braviken, with a stream connecting them.

The escarpments cannot be due to glacial action, for (1) they are neither in line with the ice motion, as shown by lakes and eskers, nor at right angles to it; (2) in cer-

tain localities the same drift is present on both sides of the escarpment, passing over the interruption, and in other places the bluff marks the boundary between two glacial formations. Whatever did cause the escarpments was local; for they are limited in extent, and besides them no others with similar alignment exist reasonably near. The only methods ordinarily found are the erosion of sedimentary strata of various resistances, and faulting. The geology of the region is that of an old-land surface, of complex structure, composed of very ancient sediments and crystallines. This could not possibly give such an escarpment by simple erosion.

The field evidence, however, leads directly to faulting as the ultimate cause of the present topography. Here the physiographer must turn to the geologist for help. But having received his answer, certain problems of erosion are thrust upon him; and he must decide whether the faulting is recent, and if not, its age and the subsequent history of the surface. These I have not found treated in the literature of the country, nor more than hinted at in conversation with Continental geologists who are acquainted with the localities.

To the south of the escarpments the rocks are Cambrian, Cambro-Silurian and Silurian sediments, with some outcrops of the pre-Cambrian crystallines close to the fault. To the north are mainly crystallines, with two outcrops of Silurian close to the bluff. In most places where the escarpments are not accompanied by a waterway the surface deposits change abruptly. In other instances no change takes place.

From the physiographic standpoint, then, it appears that the fault is an old one, of unknown date, which brought weaker Silurian and Cambrian rocks against the crystallines. The down-throw was to the south, allowing that portion of the sediments which now remains, to drop. Since

then the country has been reduced to base-level at least once, and probably a number of times; and any sediments which once extended northward over the crystallines have been eroded. The last cycle of changes has included re-elevation, revival of stream action, and etching out of the present topography in the less resistant Silurian and Cambrian, giving the appearance of a recent fault.

J. EDMUND WOODMAN.

HARVARD UNIVERSITY.

*LIFE CONDITIONS OF THE OYSTER: NORMAL AND ABNORMAL.\**

THE Committee are bringing their investigations to an end for the present, and they now state in this final report a series of the conclusions at which they have arrived. The details of the evidence upon which these conclusions are based will appear in a fully-illustrated memoir by Professor Boyce and Professor Herdman, which is nearly ready for publication. A good deal of that evidence has, however, been outlined in our former reports (at Ipswich, Liverpool and Toronto), and need not be now repeated.

Since last year's report, however, we have gone further into the question of the amount of copper and iron present in different parts of various kinds of oysters, with results which sustain the conclusions we had already arrived at.

We have also gone more minutely into the question of typhoid-like organisms, their occurrence in shellfish, and the differentiation of these from the *B. coli communis* on the one hand, and from the true *B.*

\* Third and Final Report of the Committee of the British Association for the Advancement of Science, consisting of Professor W. A. Herdman (Chairman), Professor R. Boyce (Secretary), Mr. G. C. Bourne, Dr. C. A. Kohn and Professor C. S. Sherrington, appointed to Report on the Elucidation of the Life Conditions of the Oyster under Normal and Abnormal Environment, including the Effect of Sewage Matters and Pathogenic Organisms. (Drawn up by Professor Herdman, Professor Boyce and Dr. Kohn.)

*typhosus* on the other, with the following results:

#### BACTERIOLOGY OF SHELLFISH.

In one of our previous reports (B.A., Liverpool, 1896) we drew attention to the comparatively frequent occurrence of a group of organisms giving the reaction of the *Bacillus coli*, and also of a motile bacillus, which, owing to the fact that it did not behave like the Colon bacillus in all its reactions—*i.e.*, formation of indol and gas bubbles, approached somewhat the *B. typhosus* type. Shortly after the publication of that paper Dr. Klein drew attention, in the very comprehensive Local Government Board Report, upon 'Oyster Culture in Relation to Disease,' to the frequency of the presence of the Colon bacillus in oysters, and in one instance to the presence of a bacillus which, after most careful investigation, could not be distinguished from the bacillus of Eberth. Since that date we have continued our investigations upon the bacteria present in oysters, and have further extended them to other shellfish. We have examined, during the last year, 19 batches of oysters, 17 batches of mussels, 18 batches of cockles, 5 batches of periwinkles and 1 batch of whelks; these were obtained from shops in various parts of Liverpool.

*Methods.*—The methods employed were similar to those detailed in our Report previously referred to, except that we availed ourselves of the serum reaction, and we desire to express our thanks to Dr. Christophers, who especially undertook the investigation of the serum reaction in connection with all the 'coli' and typhoid-like organisms which were isolated in the Laboratory.

*Results.*—*Oysters.*—In nine out of the nineteen batches a colon-like organism was isolated from the interior of the oysters. In some instances there was almost a pure culture of the Colon bacillus, the Petri dishes

giving a very characteristic odor. The reaction in the nine cases differed; there was the typical colon group, coagulating milk, forming indol and gas, and giving a decided acid reaction, as well as an abundant growth upon potato. There was also a group consisting of very active bacilli, not coagulating milk, not forming indol, occasionally forming gas, and in two cases giving rise to a slightly acid reaction in neutral litmus whey, and in three cases to an alkaline reaction. In each suspicious case the serum reaction was carefully tried, but always with negative results. We conclude that this latter group, although giving some of the reactions of the typhoid bacillus, cannot be regarded as identical with the true bacillus of Eberth.

*Mussels.*—The colon group is less frequent; some of the bacilla isolated coagulated milk, formed gas and indol, whilst others gave negative reactions, as in the case of the oysters.

*Cockles.*—A colon bacillus was not isolated. A coccus not liquefying gelatine, growing at a temperature of 37° C., and sometimes forming gas, was frequently met with.

*Periwinkles.*—As in the case of the previous group, a coccus was isolated.

*Whelks.*—From these a bacillus was obtained which formed gas at 37° C., did not coagulate milk nor produce indol, and only after four days produced a slight acid reaction in neutral litmus whey; it, therefore, resembled the second group found in the oyster.

These observations show the frequent occurrence of the Colon group of bacilli in such shellfish as we have investigated. Moreover, they clearly indicate that some of the organisms composing this group are more closely related in their reactions to the *Bacillus typhosus* than others are, although none corresponded to that bacillus



in all respects. It will be remembered that in our Liverpool Report (1896) we described the occurrence of the typhoid organism after various intervals of time in oysters which we had experimentally infected with typhoid material. To that report\* we may refer also for a discussion of the results of washing infected oysters in a running stream of sea-water, and for a statement of the diminution of the number of typhoid organisms as the time of inoculation recedes. In our Ipswich paper † we had shown that oysters were able to live, and did live, under very impure conditions, and were able to make use of sewage matter as food. We also demonstrated (in 1895) by experiments that those laid down in the proximity of drains contained far more micro-organisms than such as were some distance off in purer water. Finally, in last year's report at Toronto, ‡ we gave an account of the unhealthy condition of certain green oysters, of the association of the color with a leucocytosis, and of the presence of copper in the leucocytes. §

As the result of these various lines of investigation, and of the examination of oysters alive under both natural and artificial conditions on various parts of the British, French, Dutch and Italian coasts, we have arrived at the definite conclusions as to their natural history, chemistry and bacteriology, which are detailed below; and to which we have ventured to add some recommendations as to administrative and public health questions. We are convinced that all that is necessary in order that the oyster may be restored to its proper position in public estimation as a most useful, delicate and nutritious food-matter is that shellfish importing, growing and lay-

ing shall be conducted under proper supervision, and that the grounds and waters chosen for the purpose should be inspected and licensed by duly qualified scientific authorities.

#### CONCLUSIONS.

1. There are several distinct kinds of greenness in oysters. Some of these, such as the green Marennes oysters and those of some rivers on the Essex coast, are healthy; while others, such as some Falmouth oysters containing copper and some American oysters re-bedded on our coast and which have the pale green leucocytosis we described in the last report, are not in a healthy state.

2. Some forms of greenness (*e. g.*, the leucocytosis) are certainly associated with the presence of a greatly-increased amount of copper in the oyster, while other forms of greenness (*e. g.*, the Marennes) have no connection with copper, but depend upon the presence of a special pigment Marennin, which may contain a certain amount of iron.

3. We see no reason to think that the iron in the latter case is taken in through the surface epithelium of the gills and palps; but regard it, like the rest of the iron in the body, as a product of ordinary digestion and absorption in the alimentary canal and liver.

4. We do not find that there is any excessive amount of iron in the green Marennes oyster compared with the colorless oyster; nor do the green parts (gills, palps, etc.) of the Marennes oyster contain either absolutely or relatively to the colorless parts (mantle, etc.) more iron than colorless oysters. We, therefore, conclude that there is no connection between the green color of the Huitres de Marennes and the iron they may contain.

5. On the other hand, we do find by quantitative analysis that there is more

\* *Brit. Assoc. Rep.*, Liverpool Meeting, 1896, p. 663.

† *Ibid.*, Ipswich Meeting, 1895, p. 723.

‡ *Ibid.*, Toronto Meeting, 1897, p. 363.

§ See also *Proc. Roy. Soc.*, Vol. LXII., p. 30.

copper in the green American oyster than in the colorless one, and more proportionately in the greener parts than in those that are less green. We, therefore, conclude that their green color is due to copper. We also find a greater quantity of iron in these green American oysters than in the colorless; but this excess is, proportionately, considerably less than that of the copper.

6. In the Falmouth oysters containing an excessive amount of copper we find that much of the copper is certainly mechanically attached to the surface of the body, and is in a form insoluble in water, probably as a basic carbonate. In addition to this, however, the Falmouth oyster may contain a much larger amount of copper in its tissues than does the normal colorless oyster. In these Falmouth oysters the cause of the green color may be the same as in the green American oysters.

7. The colon group of bacilli is frequently found in shellfish, as sold in towns, and especially in the oyster; but we have no evidence that it occurs in Mollusca living in pure sea-water. The natural inference that the presence of the Colon bacillus invariably indicates sewage contamination must, however, not be considered established without further investigation.

8. The Colon group may be separated into two divisions—(1) those giving the typical reactions of the Colon bacillus, and (2) those giving corresponding negative reactions, and so approaching the typhoid type; but in no case was an organism giving all the reactions of the *B. typhosus* isolated. It ought to be remembered, however, that our samples of oysters, although of various kinds and from different sources, were in no case, so far as we are aware, derived from a bed known to be contaminated or suspected of typhoid.

9. Consequently, as the result of our investigations, and the consideration of much evidence, both from the oyster-growers' and

public-health officers' point of view, we beg to recommend:

(a) That the necessary steps should be taken to induce the oyster trade to remove any possible suspicion of sewage contamination from the beds and layings from which oysters are supplied to the market. This could obviously be effected in one of two ways, either (1) by restrictive legislation and the licensing of beds only after due inspection by the officials of a government department, or (2) by the formation of an association amongst the oyster-growers and dealers themselves, which should provide for the due periodic examination of the grounds, stores and stock, by independent properly-qualified inspectors. Scientific assistance and advice given by such independent inspectors would go far to improve the condition of the oyster beds and layings, to reassure the public, and to elevate the oyster industry to the important position which it should occupy.

(b) Oysters imported from abroad (Holland, France or America) should be consigned to a member of the 'Oyster Association,' who should be compelled by the regulations to have his foreign oysters as carefully inspected and certificated as those from his home layings. A large proportion of the imported oysters are, however, deposited in our waters for such a period before going to market that the fact of their having originally come from abroad may be ignored. If this period of quarantine were imposed upon all foreign oysters a great part of the difficulty as to inspection and certification would be removed.

(c) The grounds from which mussels, cockles and periwinkles are gathered should be periodically examined by scientific inspectors in the same manner as the oyster beds. The duty of providing for this inspection might well, we should suggest, be assumed by the various Sea Fisheries Committees around the coast.

## NOTES ON INORGANIC CHEMISTRY.

THE study of the influence of chemical composition on the coefficient of expansion of glass is one that has attracted considerable attention from both theoretical and practical standpoints. According to *Nature* an interesting *résumé* is given by M. A. Granger in the *Moniteur Scientifique*. In a few cases only the expansion follows an additive law proposed by Schott. A number of substances, such as the oxids of lead, calcium, manganese, aluminum and boron, lower the dilation when added in small quantities, but raise it when the proportion is increased. Potash, soda, lithia, fluorspar, lime or calcium phosphate raise the coefficient of expansion, but except in the case of the last not more than 8 per cent. can be added, as the glass either refuses to take up more or else becomes devitrified and opaque. Calcium borate, oxid of iron, alumina and silica lower the coefficient of expansion, alumina being especially active in this respect.

A SECOND series of experiments on the action of water on metals is contributed to the last *Chemical News* by Robert Meldrum. The action on iron was noticed last week in this column. He finds that all waters tested have action on copper. Seven feet of one-sixteenth inch wire was used in each case. In five months distilled water had dissolved 0.055 parts per 100,000. Ammonia and carbon dioxid free water in 115 hours' exposure contained 0.1925 parts. A lake water containing 0.0056 free ammonia, 0.0126 albuminoid ammonia and 1.756 chlorin dissolved in 24 hours 0.099 parts. A water with no free ammonia, 0.001 albuminoid ammonia and 1.22 chlorin in 24 hours dissolved 0.023 parts copper. A town water supply with 2.07 chlorin and 3.0 organic matter dissolved in 94 hours 0.0825 copper, all in parts per 100,000. Sludge from a water tube boiler in use for some

years contained 0.006 per cent. copper, showing the solvent action on copper and brass fittings. No zinc is mentioned as being present, though it is known that some waters exercise a decidedly solvent action upon the zinc in the brass, affecting but slightly the copper.

EXPERIMENTS on lead were carried out by exposing the water in pieces of new lead pipe closed at one end. Two waters were tested: one (A) of a permanent hardness of 3.2° and a total hardness of 3.3°; the other (B) of permanent hardness 5° and total hardness 18.6°. In four hours A had dissolved 3.97 parts per 100,000 and B 0.049. When containing a small amount of carbon dioxid the solvent action was unchanged, but when almost saturated with carbon dioxid the solvent action of A was after the first half hour greatly increased. When saturated with calcium bicarbonate the solvent action was greatly decreased and when water A was agitated with calcium carbonate and then filtered, it ceased to have any solvent action. These experiments bear out the generally accepted view that hard waters take up little lead from lead pipes, but that soft waters and highly carbonated waters dissolve considerable quantities.

CONTINUING his investigations of the recently prepared crystallized calcium, Moissan describes, in the *Comptes Rendus*, its action upon nitrogen. In the cold no action takes place; at a gentle heat nitrogen is slowly absorbed; at a low red heat the calcium burns in nitrogen. In these two cases calcium nitrid is formed, of a bronze-yellow color. It is probable that the yellow color previously attributed to metallic calcium is due to the presence of more or less calcium nitrid. The calcium of Moissan is a white metal. Calcium nitrid is violently decomposed by water with the formation of ammonia and calcium hydroxid. It reacts



with carbon in the electric furnace, giving calcium carbid. Moissan suggests that calcium nitrid might possibly have some industrial importance in the formation of ammonia from atmospheric nitrogen.

In the November number of the *American Chemical Journal* Professor Mallet describes an effort made to prepare what Sergius Kern had announced in 1877 as a new metal in platinum ore and named davyum. The metal possessed peculiar interest from its supposed atomic mass of 154, thus being a representative of a hitherto unknown group of platinum metals, lying intermediate between the two groups ruthenium, rhodium, palladium and osmium, iridium, platinum. Following Kern's directions and using residues furnished by Mr. George Matthey, of Johnson, Matthey & Co., Professor Mallet obtained a small residue, which agreed very closely with Kern's description of davyum. A careful examination showed that it was not elementary, but was composed of rhodium and iridium with a trace of iron. Thus the existence of an element davyum must be considered extremely doubtful.

In the same journal Professor Keiser makes a contribution to the literature of the quantitative synthesis of water. In his experiments the hydrogen, oxygen and water formed were all weighed directly. His results give for the ratio of atomic mass of hydrogen to that of oxygen 15.874 when calculated from the ratio of hydrogen to oxygen used, and 15.886 when calculated from the ratio of hydrogen used to water formed. The mean 15.88 is thus very close to Professor Morley's figure of 15.879.

J. L. H.

#### CURRENT NOTES ON ANTHROPOLOGY.

##### EGYPTIAN ORIGINS.

A RUSH of papers has recently appeared discussing the origin of the ancient Egyp-

tians. Most of them were suggested by De Morgan's work and excavations. A brief review of these, by Henry de Morgan, is in the 'Proceedings' of the American Numismatic and Archæological Society (fortieth meeting, 1898). Few of the writers altogether subscribe to De Morgan's theory of Asiatic origins. In *L'Anthropologie* (1898, Nos. 3 and 4) M. de Bissing, in a lengthy critique, condemns it as hasty and unfounded, claiming the elements of Egyptian civilization to be distinctly African. The distinguished Russian, Professor Anoutchine, and Schweinfurth, the traveler, both maintain that early Egyptian culture descends directly from the local neolithic period, and, while borrowing from Asia, was in no fair sense derived from that continent. This, too, is the position of Dr. E. Fraas, published in the *Correspondenzblatt* of the German Anthropological Society.

It is safe to conclude that De Morgan has by no means convinced his most competent critics.

##### YUCATECAN RUINS.

THE imposing ruins of a town known to the Indians as Xkichmook lie in a rocky valley about fifty miles east of Campeche. An accurate and fully illustrated report upon them by Mr. Edward H. Thompson is given in Volume II., No. 3, of the Field Columbian Museum publications. They consist of ten separate edifices of cut stone, mounds, terraces and reservoirs. Mural paintings are frequent, but mostly obliterated; incised figures are comparatively rare. Pottery is abundant, and also chipped stone implements; while polished stone objects are scarce. Obsidian is slightly represented, and metals were not exhumed.

The principal structure, called 'the Palace,' is an edifice of note. It towers eighty feet above the surrounding level, and its massive walls loom up like the face of some grim fortress.

## SLAVIC ANTIQUITIES.

PROFESSOR DR. LUBOR NIEDERLE, of the University of Prague, is widely and creditably known as one of the leading Slavic anthropologists; and it is quite appropriate, therefore, that he should appear as editor of a journal devoted to the collection of works and essays on Slavic archæology (*Vestník Slovanských Starozitností*), the first number of which has recently been issued. Its articles are printed either in Czech, Russian, German, French, English or Latin, as a learned Slav is quite indifferent to such a trifle as languages. They offer careful reviews and synopses of the contributions to this branch from all the avenues of scientific literature. The journal is so useful that it will surely be well patronized by the Slavonic antiquaries.

## ANCIENT LABOR UNIONS.

A POWERFUL social force, which the ethnologist is apt to overlook, is that of the commercial and labor unions which we call 'gilds.' An excellent illustration of their influence in early society is presented in an article by Professor E. W. Hopkins in the *Yale Review* (May and August, 1898). He studies them as they have existed in India for nearly 3,000 years. In the Laws of Manu the rules of the gilds are reckoned on a par with those of castes and families. Five hundred years later they had reached such a degree of supremacy that the precept is laid down: "The king must approve of whatever the gilds do, whether it is cruel or kind!" The most rabid labor unionist of our time could not wish for more.

D. G. BRINTON.

UNIVERSITY OF PENNSYLVANIA.

## SCIENTIFIC NOTES AND NEWS.

BULLETIN OF THE U. S. GEOLOGICAL SURVEY  
DESCRIPTIVE OF THE EDUCATIONAL  
SERIES OF ROCK SPECIMENS.

PERCEIVING that the field parties of the United States Geological Survey had, in the

course of their regular work, exceptional opportunities for making such a collection, it was determined by the Director of the Survey away back in 1882 to have these parties collect duplicate type specimens of rocks, with a view to the making-up of suites for the use of the educational institutions of the country for teaching purposes. Under the immediate direction of Mr. J. S. Diller, who has had the assistance, from time to time, of other geologists and petrographers, the work of collecting was begun and carried to completion and the material was segregated, numbered and described. The suites, numbering two hundred and fifty and comprising about one hundred and sixty specimens each, were about a year ago distributed to the universities, colleges and other institutions of learning which had made application therefor.

An important feature of the undertaking, however, was still unfinished when the suites were sent out, viz., a hand-book for the use of the student. This has just been printed. It comprises 400 pages of text and 65 illustrations. It is devoted in the main to descriptions, written by sixteen different specialists connected with the Survey, of the rocks comprising the collection, although it also contains chapters on rocks in general and their study, including observations on structural features, methods of physical analysis, the principal rock-making minerals and rock classification. The work, which will be a valuable accessory to a valuable rock collection, is published as Bulletin 150 of the Geological Survey series, under the title, 'The Educational Series of Rock Specimens, collected and distributed by the United States Geological Survey, by Joseph Silas Diller.' The cost of the bulletin is 25 cents, and it may be obtained by applying to the Director of the U. S. Geological Survey, Washington, D. C.

W. F. M.

## THE GERMAN DEEP-SEA EXPEDITION.

PROFESSOR CHUN, the leader of the German Deep-Sea Expedition, has sent to Sir John Murray some account of the progress of the work since the expedition left in August last on the steamship *Valdivia*, and this forms the basis of an article in the London *Times*. It will be re-

membered that the German Parliament voted 300,000 Marks towards its equipment. Additional grants will be made to cover further expenses and the cost of publishing the scientific results. Professor Chun is accompanied by a staff of eleven scientific men, each of whom receives eight Marks per day from the Government, and their lives are insured for 30,000 Marks each.

The route to be followed may be divided into three portions: (1) From Hamburg round the north of Scotland to the Canary Islands, past the Cape Verd Islands, touching at the mouth of the Cameroons and Congo Rivers and Wal-fisch Bay to Cape Town; (2) from the Cape of Good Hope the Agulhas Bank will be examined, thence the expedition will proceed southwards past Prince Edward Island to the edge of the Antarctic ice, returning northwards through the center of the Indian Ocean to the Cocos and Christmas Islands, and thence to Padang, in Sumatra; (3) from Padang to Ceylon, thence calling at the Chagos, Seychelles and Amirante groups to Zanzibar, returning home by Sokotra, the Red Sea, Suez Canal and the Mediterranean.

The results so far obtained are of great interest to naturalists and oceanographers. Serial temperature observations were taken in the warm and cold areas of the Farøe Channel, respectively south and north of the Wyville-Thomson Ridge, which separates the ice-cold polar water flowing southwards from the warm Atlantic water flowing northwards. Regular observations were made on the specific gravity of the surface waters, and, as opportunity offered, on that of the deeper waters, also on the density, color and transparency of the water, and on the direction of the surface currents. A meteorological register is kept, in which observations are entered every four hours day and night, and self-registering instruments give continuous records of the barometric pressure, the temperature and humidity of the atmosphere. In the chemical laboratory the gases and chlorine contained in many deep-sea waters have been determined.

The samples of deep-sea deposits are collected and preserved by the chemist under Professor Chun's personal supervision. In some

of the deposits the bacteriologist has observed many forms of bacteria, and in the samples of water from the greater depths various species of bacteria have also been found. The dredgings and trawlings, and the observations with closing nets in intermediate waters, have yielded results of the greatest importance. The closing tow-nets and large vertical nets have been used with remarkable success. Many deep-sea crustaceæ and fishes, which were taken in the dredge and trawl by earlier expeditions and were, therefore, supposed to live on the bottom, have been proved to live a pelagic life, floating or swimming in the intermediate waters. The botanist is paying special attention to the contents of these closing nets, with the view of determining to what depth below the surface living diatoms, peridinæ and protococcaceæ descend.

On the way to the Canary Islands observations were made in the neighborhood of the Josephine and Seine Banks, which rise steeply from the ocean bed to within less than 100 fathoms beneath the surface of the North Atlantic. Around the Seine Bank series of soundings and temperatures were taken, and the dredgings showed a great abundance of crinoids (*Antedon phalangium*), hydroids and antipathids. The expedition proceeds from the Canaries, by way of the Gulf of Guinea, to the Cape of Good Hope, Cape Town being reached early in November, and before it sails towards the Antarctic ice the Agulhas Bank will be systematically explored. This expedition may be regarded as to some extent preliminary to the Antarctic expedition which will leave Germany in 1900.

#### GENERAL.

THE American Humane Society meets in Washington next month and it is expected that it will attempt to secure the passage of the vivisection bill now pending in the Senate. It is important that men of science and physicians should use their influence, especially by direct communication with their respective Senators, to prevent the passage of a bill that will interfere with the progress of science in the District of Columbia, and which may exert a harmful influence throughout the country.

THE Hurley Bill, providing for the adoption



of the metric system of weights and measures in the United States and its compulsory use in all government transactions except the completion of surveys of the public lands, will be brought up in the approaching session of Congress. The bill, it will be remembered, was defeated by only three votes in the 54th Congress and the increased interest in the foreign trade of the United States seems likely to influence its passage this winter. Scientific societies and men of science should exert such influence as they possess to call attention to the importance of the measure.

THE American Chemical Society will hold its winter meeting in New York City, beginning on December 27th.

THE eleventh winter meeting of the American Geological Society will be held in New York City, beginning on Wednesday, December 28th, in the geological lecture room, Schermerhorn Hall, Columbia University. The Council will meet on Tuesday evening, at the Endicott Hotel, the headquarters of the Society, and also Wednesday morning. The Society will be called to order by President Stevenson at 10 o'clock a. m. The President's address will probably be given on Wednesday morning, and the usual subscription dinner will be on Thursday evening. The list of papers will be mailed to Fellows on December 6th.

THE Biological Laboratory of the United States Fish Commission at Woods Holl will be open throughout the winter to those who may desire to avail themselves of the opportunities afforded for investigation in maritime zoology and embryology. Several of the winter fishes have already begun to breed, and the surface fauna is materially different from that of the summer months. The Laboratory is provided with steam heat, and a limited number of rooms in the residence are available. Applications should be addressed to the Director, Dr. H. C. Bumpus, Woods Holl, Mass.

IN connection with the approaching meeting of the New York State Science Teachers' Association it is proposed to hold an exhibition of pieces of apparatus useful in teaching science. Those who wish to examine special instruments are requested to communicate with Professor

R. E. Dodge, Teachers College, New York, and efforts will be made to have the instruments on exhibition.

THE annual convention of the Association of Agricultural Colleges and Experiment Stations met last week in Washington.

MR. STANLEY FLOWER, of the King of Siam's Museum, at Bangkok, has been appointed Superintendent of the Cairo Zoological Gardens.

DR. MARCUS S. FARR has been appointed curator of the zoological collection of the New York State Museum, University of the State of New York, Albany.

A BUST in relief of the physiologist, G. von Fleischl-Marxow, who died in 1891, has been unveiled in the Court of the University of Vienna.

AT a meeting of former instructors, fellow students and students of the late James Ingram Peck, at John Hopkins University on November 5th, the following resolution was adopted.

Whereas we cannot forget that James Ingram Peck exemplified in his own life all those high qualities of enthusiasm for truth, of devotion to scientific research and of earnestness in the instruction of others, which it is the chief aim and best reward of a university to diffuse among men :

We, therefore, resolve that :

While we mourn the untimely loss of one who had been the earnest and faithful pupil of some among us, the enthusiastic and inspiring fellow student or the patient, kindly and helpful teacher of others, we are glad to remember his devotion to the highest and best work of a learned man and his success in handing on to his associates his unselfish enthusiasm in the pursuit of truth.

EDWIN A. KIMBALL, an inventor and mechanical expert formerly superintendent of the mechanical department of the University of Illinois and the Illinois Industrial Home for the Blind in Chicago, died in that city on November 14th, aged 64 years.

WE have also to record the death of M. Alexander Pilliet, Curator of the Musée Dupuytren, the anatomical museum of the University of Paris and well known for his contributions to morbid anatomy. He died in Paris on November 2d, at the age of 38 years.

THE death is announced of John W. Keely in Philadelphia, on November 18th. Mr. Keely,

as is well known, secured great notoriety and a considerable amount of money by a mysterious motor, a description of which has never been given in intelligible terms.

THE Royal Geographical Society, London, has subscribed £5,000 towards the British Antarctic Expedition.

A NUMBER of British and American residents in western China have, as we learn from the London *Times*, addressed a memorial to Lord Salisbury on the obstacles to and delays in communication between the upper and lower waters of the Yang-tze. These are, the memorialists say, not only a hindrance to trade, but also a danger to the lives and properties of missionaries and others resident in the interior, on account of the difficulty of affording proper protection against rioters. Mr. Little's experiences have proved that the rapids are navigable, but they also show the necessity of a careful survey of the river from Ichang upwards before steam communication can become regular and profitable, and hence the memorialists ask Lord Salisbury to consider the propriety, in the interests of British residents and British trade in western China, of instituting such a survey by naval experts at an early date.

DR. CHARLES F. MILLSPAUGH, curator of the botanical department of the Field Columbian Museum and lecturer in the University of Chicago, is about to leave New York in the yacht *Utowana* for the coast of Yucatan with a view to studying the flora of the interior of the country. This is Dr. Millspaugh's fourth expedition to Yucatan.

A NEW steamship, *Pathfinder*, for the U. S. Coast Survey will be launched on December 7th. It was designed especially for work in Alaskan waters and is said to be the finest vessel ever built for work of this character.

ON recommendation of the Franklin Institute the Board of Directors of Philadelphia City Trusts have awarded medals purchased by the John Scott fund to John W. Hyatt, of Newark, N. J., for his elastic spiral anti-friction roller; to Melvin L. Severy, of Arlington Heights, Mass., for his impression process, and to Henry Lyman Sayen, of Philadelphia, for his improvement in Röntgen-ray tubes. The in-

come of the medal fund, which was created in 1816, is willed by the testator "to be laid out in premiums to be distributed among ingenious men and women who make useful inventions, along with which shall be given a copper medal."

THE Paris *Temps* states that Professor Grassi has discovered in the laboratory of the hospital of Saint Esprit, at Rome, the bacillus of malaria. Its host is said to be an insect of the mosquito family.

SURGEONS Wasdin and Geddings, who have spent about a year studying yellow fever in the South, have been sent to Havana to continue their studies there. Their previous work has, it appears, to a certain extent, confirmed the researches of Sanarelli.

THE commission to be sent by the British government to India to investigate the plague, to which we recently called attention, has now been appointed and consists of Dr. Thomas R. Fraser, F. R. S., professor of materia medica and clinical medicine at Edinburgh University, who has accepted the duty of President, and with him will be associated two other scientific experts, Dr. Wright, professor of pathology at the Army Medical School, Netley, and Dr. Rüffer, who has been for some time head of the Egyptian Sanitary Department at Cairo. Two officers of the Indian Civil Service, Mr. J. P. Hewett, C. I. E., and Mr. A. Cumine, both of whom have had much to do with recent plague affairs in India, have also been appointed to the commission by the government of India. The scope of the commissioners' inquiries will include: (1) the origin of the different outbreaks of plague; (2) the manner in which the disease is communicated; (3) the effects of certain prophylactic and curative serums that have been tried or recommended for the disease. The members of the commission will reach Bombay towards the end of the present month.

THE plague in Bombay is showing some abatement, the deaths during the last week in October having decreased to 96. In the Presidency of Bombay no less than 5,000 deaths occurred during the week, and an increase has occurred in the Mysore state, 400 deaths being recorded in Bangalore alone. It is supposed

that there is a serious outbreak of the plague in the Samarkand district, the Russian government having sent thither 40 physicians, but no details can be obtained. An isolated case has occurred in Warsaw.

THE British Colonial Office has requested the Royal College of Physicians to report to it on the communicability of leprosy, and the question has been referred to a committee consisting of Sir D. Duckworth, Drs. R. Liveing, Payne, Hebb, Heron and J. Anderson, with power to confer with others not belonging to the College.

*Nature* quotes from the *Sydney Daily Telegraph* of September 9th particulars as to the coral-boring operations at Funafuti, news having been received via New Zealand, through the U. S. S. Co.'s steamer *Poherua*, which coaled H. M. S. *Porpoise* at Funafuti, as to the progress of the two bores, one on land, and the other in the lagoon of that coral atoll. With regard to the lagoon bore, operations were commenced on August 15th, Commander Sturdee having succeeded in mooring the warship so taut that it was possible to work the boring pipes without risk of their bending or breaking from the bows of the warship. Mr. G. H. Halligan, who is in immediate charge of the boring plant, reports that for the first twenty-four hours of boring a depth of 109 feet was attained, the total depth of the bore being 212 feet below the water level of the lagoon, the depth of water to the bottom of the lagoon being 103 feet. The *Poherua* left at the end of the first day's boring. As regards the nature of the material bored, Mr. Halligan states that the first 80 feet below the bottom of the lagoon were formed of sand, composed of joints of Halimeda (a seaweed which secretes a jointed stem of lime) and of fragments of shells. The remaining 29 feet were in similar material, but containing small fragments of coral getting larger at the deeper levels. The deepening of the old bore, discontinued last year at a depth of 698 feet, on the main island of Funafuti, has been proceeding slowly but steadily. The party were landed there by the London Missionary Society's steamer *John Williams*, on June 20th last. As was anticipated, little difficulty was experienced in re-

driving the lining pipes into the old bore and washing out the sand and rubble which had choked the bore-hole. Pipes were laid from the site of the old bore to some small water-holes, from which a supply of fresh water was obtained for the boiler. By July 25th, the relining and cleaning of the boiler having been successfully accomplished, boring was resumed, and up to the time when the steamer *Poherua* left, a depth of 840 feet had been reached. The bore last year terminated in soft dolomite limestone at 698 feet, but it has now been ascertained that below this is a hard rock, so hard that the portion of the bore-hole which penetrates it no longer needs to be lined with iron pipes, a condition which must facilitate the work of boring. Mr. A. E. Finckh reports that this hard rock is largely composed of corals and shells. The depth of 840 feet is exactly the crucial depth which it was hoped the bore might reach, and, if possible, exceed, as at a corresponding depth on the ocean face of the reef there is a strongly marked shelf, as shown by the soundings by Captain A. Moysten Field, of H. M. S. *Penguin*, and it is considered that this shelf, at the 140 fathoms' level, marks the downward limit of the coral formation.

THE Department of Agriculture of the Cape of Good Hope has issued, according to *Natural Science*, 'The Report of the Marine Biologist for the year 1897,' by Mr. J. D. F. Gilchrist. In the report for 1896 and in the present report reliable information has been published relative to the fishing industry and fishing centers of the colony. The colonial government is now in a position to appreciate the value of this important industry and the possibilities of its development, and to legislate on matter which may arise in regard to it. In order to satisfactorily investigate the fishing grounds one of the most modern types of steam vessels was procured, together with a skilled crew, and they set to work with long lines, nets and trawl. So far it is found that there is within easy reach of Cape Town an excellent trawling ground, rivaling the North Sea in productiveness, and among other excellent fish, soles occur there abundantly, some of them turning the scales at 8 and 9 pounds, from near St. Helena Bay. The future work of the *Pieter Faure*, as the



vessel is called, will be the investigation of the Agulhas Bank from Mossel Bay and Port Elizabeth, Knysna, Port Alfred and East London. The scientific aspect of the work will be kept in sight, but for the present more attention must be given to the industry. Considerable opposition has been made to the operations of the steam trawler, but it has been pointed out that Parliament was only experimenting at present, that proper investigation would be made into the alleged disturbance of spawn and the fishing limits for ordinary fishermen, but that the store of food available round the coast would certainly be exploited in a country clamoring for cheap food, and that the interests of a large country would outweigh the interests of a few individual fishermen. The report contains some valuable charts, descriptions of a new *Arnoglossus* by Mr. Boulenger, and a new genus of gasteropoda *Neptuneopsis gilchristi* by Mr. G. B. Sowerby, besides much other statistical information.

A LARGE number of visitors, as we learn from the London *Times*, assembled at the shipyard of Messrs. W. G. Armstrong, Whitworth & Co., Walker-on-Tyne, on October 29th, to witness the novel launch of an icebreaking steamer, said to be the largest in the world, which the firm has built for the Russian government. The vessel is the pioneer ship of what may be termed pelagic icebreakers. The dimensions and appearance of the vessel would suggest a battleship were it not that the bow is cut away and forms an exceedingly long overhang, which serves the double purpose of breaking the ice with which it comes in contact and of protecting the forward propeller. The principle upon which the new vessel attacks the ice is by force, augmented by science. The forward propeller, by disturbing the water under the ice, deprives it of its support, and then renders it a comparatively easy task for the heavy vessel to break through it. The principal dimensions are: Length 305 feet, breadth 71 feet, and depth 42 feet 6 inches. When fully loaded the draught will be 25 feet, and the corresponding displacement about 8,000 tons. The propelling machinery has been divided into four sets, of which three sets are aft, each driving its own propeller, and one set forward. The combined

power of these four sets of machinery will be 10,000 horse-power. There is accommodation for 30 first-class passengers, 10 second-class and 50 third-class passengers, besides that for the captain, officers, engineers and crew of the vessel. There is ample capacity for cargo, so that the vessel, in addition to conveying merchant vessels through the ice, is herself capable of carrying a heavy cargo. The stern of the icebreaker is cut to form a recess, into which the stem of another vessel can be securely lashed, and thus obtain the utmost protection from her powerful consort. Admiral Makaroff has also in view the possibility of augmenting the icebreaking capabilities of this vessel by having the assistance of a second vessel pushing her, as to which he has already made experiments.

THE British Select Committee on the Museums of the Science and Art Department recommended that the collection of preserved fish bequeathed to the nation by the late Professor Buckland should be abolished. In view of this action the Piscatorial Society has adopted a request that reads as follows: The committee inspected the collection, which they found in a deplorable condition and quite inadequate to carry out the testator's intentions, evidently owing to absolute neglect since it was taken over. There being no catalogue, it is impossible to determine how much of the original collection still exists. The purchased additions apparently consist of something less than two dozen specimens, the majority of which have no direct bearing upon British fish industries. A large amount of the space allotted to the exhibit is taken up by objects which, however interesting in themselves, have no connection with either fish or fisheries. Your committee fully endorse the opinion of the Select Committee of the House of Commons as to the danger arising from the specimens preserved in spirits, as the building is certainly unsuited for the storage of such exhibits, but fail to see the point of the objection as regards the Buckland bequest, inasmuch as the majority of the fish in alcohol belong to the Day collection, which is not in any way an industrial exhibit and should be placed in the Natural History Museum. As regards the testator's intention to

provide a consulting and reference room for his fellow-countrymen, whether interested in sea or river fisheries, your committee are of opinion that such an educational center is urgently needed, and that the collection in question, although inadequate through neglect, is capable of being brought up to date and of taking the place contemplated for it by the donor. Subject to Mrs. Buckland's life interest, a sum of £5,000 was bequeathed to the Director and Assistant-Director of the South Kensington Museum, in trust for the British nation, to provide lectures on fish culture in connection with this unique series of specimens. Your committee, however, have failed to ascertain what has been done with this money. All that they know is that no such lectureship exists, despite the statement of Mr. George Bompas in his 'Life of Frank Buckland,' published in 1885, that after the death of Mrs. Buckland '£5,000 was given to found a lectureship.'

THE British Institute of Preventive Medicine, says *Nature*, which was founded with the view of establishing in this country a national home for bacteriological work in all its branches, has made considerable progress towards the achievement of this aim during the past few years. The bacteriological laboratories are now fully organized, the serum therapeutics laboratory is on a firm footing, whilst the application of bacteriology to hygiene are finding full recognition. A further addition has just been made to the departments of the Institute in response to the growing demands of the times. A large laboratory at Chelsea has been assigned to investigation and instruction in technical bacteriology. In this laboratory the agriculturist, the chemist, the brewer and others will find the instruction provided that they individually require for successfully employing the living agents of fermentation. Investigations will also be undertaken, and it is hoped that the laboratory will become a center of useful work, and promote the advancement of a line of research of the greatest importance to the industries of the country. We have had hitherto to rely upon the research work of foreign laboratories in this direction. The laboratory has been named the Hansen laboratory, in recognition of the pioneer work of

the distinguished investigator, and will be under the superintendence of Dr. G. Harris Morris. The formal opening of the British Institute will take place early in the new year, when the public will have an opportunity of inspecting the provisions made for furthering the objects of the Institute. The occasion will also be marked by the issue of a fresh volume of *Transactions* of the Institute.

A ZURICH correspondent writes to the *London Times* that the attention of the Swiss Federal authorities has lately been drawn to the inadequate administration of the law for the protection of birds of passage and song birds in the Canton of Ticino. In the migration seasons of the year the destruction of these birds increases to such an extent that larks, starlings, finches, the titmouse, etc., are being offered in the public markets of Lugano and Ticino for 1*f.* the dozen, and are served as a staple article of food even in the cheapest restaurants. The birds in their southward passage are caught by nets, decoys, snares and traps of every kind, and the poverty of the rural Italians in the district serves as an additional inducement for making a hasty profit from the wholesale destruction and capture of singing birds. The evil is notorious and one of long standing, but Swiss law forbids the use of snares, traps, nets and decoy birds, and it is hoped the Federal and Cantonal authorities will be awakened to the necessity of dealing with this systematic neglect of the law. North of the Alps bird life is well protected throughout the Cantons, and here the tameness and abundance of the birds, which so many visitors to Switzerland have noticed, are the best testimony of the value of such protective laws when effectively administered and backed up by public opinion.

---

#### UNIVERSITY AND EDUCATIONAL NEWS.

PRESIDENT DWIGHT has presented his resignation from the Presidency of Yale University on the ground that he has reached his seventieth year. The Corporation has passed a minute urging him to retain the Presidency until the bi-centennial celebration in 1901, but it is said that President Dwight will retire at the end of the present year. At the same meeting of the

Corporation Professor George H. Brush resigned the Directorship of the Sheffield Scientific School, which he has held for twenty-six years, and Dr. R. H. Chittenden, professor of physiological chemistry, was elected Director.

WE understand, though the complications and delays of the law are difficult to follow, that the Supreme Court of the United States has finally rejected the application for a revision of the distribution of the Fayerweather estate, and that the colleges may now make use of the money they have received and will soon be given the balance due them.

THE will of the late Dr. Thomas Seton Robertson, which left the greater part of his property to the medical department of the University of Vermont, is being contested by his wife, against whom he had begun two years ago a suit for divorce.

A PSYCHOLOGICAL laboratory is being fitted up at Wells College, and a course in experimental psychology will be given by Miss Washburn, professor of philosophy.

MR. SWALE VINCENT, has been elected to the Sharpey Physiological Scholarship (£150 per annum), University College, London, which carries with it the post of chief assistant in the physiological laboratory. In the annual election for fellowships in St. Johns College the two fellows chosen were Mr. R. C. Maclaurin, (mathematics) and Mr. V. H. Blackman (botany).

PROFESSORS BEEBE AND PIERPONT have been promoted from assistant to full professors of mathematics in Yale University. In the same University Dr. G. P. Eaton has been appointed assistant in osteology in the Peabody Museum.

AFTER listening to a report on the condition of commercial education at home and abroad the New York Chamber of Commerce has, according to *Bradstreet's*, adopted resolutions advocating measures looking to the improvement of such education in the United States. Premising that the conditions of modern commerce and industry require wider knowledge and higher education on the part of business men, the resolutions declared that the present educational facilities afforded to business men in busi-

ness colleges and similar institutions are inadequate and fail to equip them for competition in the world's commerce. The chamber went on record as favoring the establishment and development of sounder commercial education, both in secondary schools and higher institutions of learning throughout the country. The appointment was directed of a special committee to inquire further into the subject of commercial education, the committee being instructed to lay before the Chamber such plans as might best aid in attaining the end proposed. The superintendent suggested the inspection of commercial high schools by representatives of the Chamber, and the submission to such representatives of the courses of study prescribed there.

#### DISCUSSION AND CORRESPONDENCE.

##### MEASUREMENTS OF PRECISION.

TO THE EDITOR OF SCIENCE: A communication in the current number of SCIENCE under the caption 'Measurements of Precision' and over the letter 'X' seems to call for some reply. I suppose that it is generally the case that the director of a laboratory assumes responsibility for articles emanating from his laboratory with his sanction—at any rate I am always willing to do so—and this is my reason for taking up this matter in place of Mr. Taylor. Of the general tone of the article in question I prefer to say nothing, leaving it to less interested persons to judge in the matter. I shall content myself with replying to the criticisms and questions of the writer.

The upshot of the communication, freed from the subtle vein of humor which runs through it, is that Mr. Taylor has committed the heinous offence of transcribing from his note-book more figures than the results justify. Perhaps the easiest way to treat this charge is to admit it at once, and thus clear the way. I am not, however, disposed to stop there, but shall consider the statements of 'X' as they are made. The first offence is that Mr. Taylor tabulates his measurements of the diameter of a cylinder twenty centimeters in diameter to '*thousandths and ten-thousandths of a millimeter*, thus implying that his measures are made to one part in two millions.' I have always urged upon my



students that they put down everything they do, so that it may be judged how it has been done. My views are that when one puts down figures that he did not observe he perpetrates a lie, but that when he puts down figures that do not agree, or carries them too far, he simply makes himself unnecessary labor, but deceives nobody. It is easier to throw off the unnecessary figures at the end than to find out what was observed if it is not stated. I presume that this will explain the reason for Mr. Taylor's putting down the readings of the micrometers of the cathometer as actually read, that is, to a thousandth of a millimeter. It is not stated that several settings would agree to this amount, but that the figures given are the means of several settings. In the next column, in which the ten-thousandth of a millimeter appears, 'X' might have noticed, with a little more careful reading, that the last figure is invariably a five or zero, as each entry is the mean of two. I am not aware what procedure 'X' would adopt in taking means. As the result of all the measurements of the coil, the mean diameter of the coil is presented to seven figures. Now it is not a little singular that in Lord Rayleigh's celebrated paper on Clark cells, in the description of the current-weigher, of which ours is a humble imitation, the mean radius of the two coils is given to exactly seven figures, the results being 'derived from the dimensions recorded in Professor Maxwell's handwriting in the laboratory note-book.' Lord Rayleigh did not even think it necessary to unwind the coil, and it evidently did not occur to him how mortified Maxwell would have felt had he been charged by 'X' with 'implying that his measures were made to one part in two millions.' Of course, Mr. Taylor ought to have known that what Maxwell could do he could not. I charge myself with remissness in not having impressed this upon him.

With regard to the inquiry as to the maker of the cathometer, 'of a type so extraordinary as to justify these figures,' it was a fine instrument by the Société Genèveise, fastened to the wall, a photograph of which appears in the May-June number of the *Physical Review*. The levels upon it were by the same makers, whose names there is no motive for concealing.

With regard to the statement that a degree of change of temperature would probably change the length of the bar by fifteen or twenty thousandths of a millimeter, I find that, according to Benoit's results for steel, the part of the bar used would change by about *two* thousandths, so that 'highly perfected methods of determining the temperature' were not used. We have several thermometers capable of reading half-degrees.

The culmination of 'X's' sarcasm is, however, reached in the comment on the computation of the constant, in which it is stated that the last figure stands for *one part in thirty millions* (italics 'X's'). It is a fact that Lord Rayleigh only uses seven place figures, Mr. Taylor eight. These he took from Legendre's tables, throwing off the superfluous figures at the end, where the constant is given to *four* figures, not eight. If 'X's' representation in this case be ingenious I prefer Mr. Taylor's deception. The fact that the computation 'made by other people and a different method' gives a result differing by one part in a thousand (not in five or six hundred, as stated by 'X') does not throw any discredit on the measurements, but shows that the approximation of the first mode of *computation* was not sufficient, as is plainly stated.

I will not stop to dwell on the comments on the weighings. They are of the same sort, and may be answered in the same way. To the last figure, although observed, no weight is to be attached. The supposed 'marvelous skill' required thus disappears. But to conclude: What, it may be asked, is the use of printing a paper in which the main result, as is frankly stated, is disappointing? To this I may make a brief answer, though it is not touched upon in the communication. The subject of the determination of current in absolute measure is one that is now very much in the air. It becomes important to know what is the best form of measuring instrument, and what is the best method of computation of the constant. To this matter some of the last work of Helmholtz was devoted. The question of computation has been attacked with great vigor by Principal J. Viriamu Jones. An elaborate current-weigher of the Rayleigh type was constructed by the

English Board of Trade. On my inquiring last year how the constant had been calculated I was informed by Principal Jones that it had never been calculated at all. It accordingly seemed to me that the record of any experience with current-weighers, seriously made, would be useful, and that something might be learned therefrom. The instrument in question was constructed four years ago, as a preliminary instrument. Mr. Taylor's experiments were all made before the constant was calculated. This was unfortunate, but unavoidable. When the computation was made it was found that the design of the instrument was unfortunate. Was all the work done, therefore, to be thrown away, or should it go on record for the possible information of others? What is shown by Mr. Taylor's paper is the accuracy with which it is possible to make and measure Cadmium cells, and a determination, by a method independent of the potentiometer method, of their value in terms of Clark cells.

In conclusion, it is only fair to state that Mr. Taylor did not invent the practice of displaying more figures than are useful. In the very last edition of Everett's 'C. G. S. System of Units' still appears the quotation of Professor Miller's comparison of the pound and kilogram, in ten figures, although comparisons of three pounds at the Bureau International des Poids et Mesures differed in the fifth figure. Colonel Clark's comparison of the meter and yard is also given to nine figures. These figures have appeared for years in every British text-book of physics. We are told that death loves a shining mark. In this he apparently differs from our lively 'X,' who, instead of turning his attention to familiar instances, seems to prefer to make merry over a man appearing for the first time before the scientific community, who will presumably not hit back.

A. G. WEBSTER  
(*alias* 'Y').

CLARK UNIVERSITY, November 7, 1898.

#### A TRIP TO THE TERTIARY FORMATIONS OF WYOMING AND COLORADO.

THE Tertiary fossil beds of southwestern Wyoming have been of great interest to all paleontologists on account of the great beauty

and the abundance of fossil fishes, plants and insects found in the shales of the Eocene period.

The fossils are darkened by much carbonaceous, organic matter, and are thus brought out in fine contrast and exquisite detail on the white, calcareous matrix.

The writer has always had a great desire to visit the locality, but found no opportunity of doing so until the past summer, when three weeks were spent in making excavations into the high bluffs to be seen from the station called Fossil, on the Oregon Short Line Railroad. The station is at an altitude of 8,000 feet. The fossil beds are nearly 1,000 feet higher, and above these beds are 200 feet of overlying rock. Much of this has to be removed to gain access to the fossils. The excavations are made on terraces, or shelves, along the face of the bluffs, and the work is quite laborious, and oftentimes very disagreeable from the dust constantly blown about by the wild winds of that region.

The locality is utterly barren and cheerless, the bluffs rising up from sand plains on which nothing grows but sage brush. Even in August and September it was quite cold, and icicles were hanging from the water tank at the station.

While on the bluff, three miles southwest of the station, we had our home in a stone house cut into the face of the cliff, the floor being the solid rock, on which we lay at night rolled up in our blankets. Every night the mountain rats swarmed in upon us, making it almost impossible to get any rest. All the water used had to be packed over from the east side of the mountain from the only spring of drinkable water in that vicinity; even this was quite alkaline. All these discomforts were cheerfully endured and compensated for, in making one of the finest collections ever obtained from that locality.

Beautiful palms and other plants, and hundreds of fishes and insects were obtained. From Fossil a trip was made into Utah, where some fine minerals were secured. After a week of rest at Salt Lake City the road homeward was taken, by way of the Colorado Midland, stopping over two weeks at Florissant, Colo., where over 700 beautiful specimens of fossil plants and insects were obtained from the

world-renowned Miocene beds of that locality. In the immediate vicinity are to be seen the petrified remains of an ancient forest. One of the stumps measured fifteen feet in diameter. The whole surrounding country shows the effects of igneous action in past ages. This is especially noticeable in the rear of the post-office in Florissant, where the granites are rent into fearful chasms, and where several deep, extinct geyser funnels may be seen, worn on the interior perfectly round and smooth by the action of water.

A trip was taken to Crystal Peak, four miles north of Florissant, where some fine Amazon stone was obtained. This completed the work of collecting, which, in every respect, has given very gratifying results.

S. WARD LOPEL.

WESLEYAN UNIVERSITY,  
November 5, 1898.

#### THE PROPOSED CATALOGUE OF SCIENTIFIC LITERATURE.

IN SCIENCE for October 28th there is a notice of the Second Conference on an International Catalogue of Scientific Literature, and it is said that a decimal system has been recommended.

At this critical time (before the work has been begun) there ought to be open discussion by cataloguers, and the most liberal attention given to the wishes of the users of such a catalogue. A repetition of the English catalogue, monumental but not used, is to be avoided. The most important characteristic of a catalogue of scientific literature ought to be its convenience to the user; this quality ought to prevail over all other qualities of such a catalogue. The possible wants of a user of the catalogue should be constantly thought of and provided for by the cataloguer.

The user is interested in his subject, probably not in cataloguing. He wants to find quickly and easily what has been published on a certain branch of Science. He does not want to learn a system of classification nor its method of application, as he would have to do in the case of the decimal system. He wants to find his subject in the alphabetical order, as he would in an encyclopedia; first the title, then the date, then the author and the size of the work.

The list of subjects should be derived from the titles as they are being collected, and it should be arranged in alphabetical order, for the convenience of the user.

In doubtful cases and where more than one branch of a subject is treated in a paper a title should be repeated under as many subjects as by the most liberal construction a user is likely to look for it, with too many repetitions rather than too few.

Ask the users if I am not right; and for whom else is the catalogue to be prepared?

In a case like that of the great English Catalogue of Scientific Papers, where the titles are arranged in the order of the authors' names with a number against every title, the numbers only need be collected and classified; or the numbers and the dates (though this would perhaps double the cost of publication). And here again the user should be considered by making the list of subjects large and by putting them in alphabetical order.

ALFRED TUCKERMAN.

NEW YORK, November 5, 1898.

#### SCIENTIFIC LITERATURE.

*Charles Darwin and the Theory of Natural Selection.* By EDWARD B. POULTON. New York, The Macmillan Co. 1896.

This was not only a very timely book when it appeared, but will always be one of the minor classics of evolutionary literature. It is well and clearly written, compact, and a most handy book of reference for the student of Darwin's life and work, by a sincere and orthodox Darwinian. Not only does Professor Poulton give us the leading facts in Darwin's life, but in a happy and skillful way he tells the secret of his greatness, when and how the fact of evolution was impressed upon him, and the date when the idea of natural selection as an efficient cause was suggested to him. The two discoveries of Darwin which led him to reflect on the principle of evolution were, first, the fossil armadillos of the Pampean deposits and their relation to those now living, which led him to remark, in 1837, in his 'Naturalist's Voyage round the World': "This wonderful relationship in the same continent between the



dead and the living will, I do not doubt, hereafter throw more light on the appearance of organic beings on our earth, and their disappearance from it, than any other class of facts." The other discovery was the astonishing diversity between the species or local varieties of the Galapagos Islands and the evident deviation of the fauna from the nearest continent. As he exclaims: "Reviewing the facts here given, one is astonished at the amount of creative force—if such an expression be used—displayed on these small, barren and rocky islands; and still more so at its diverse and yet analogous action on points so near each other." This occurrence of extremely localized forms is a matter of special interest at the present day, because it is due largely to isolation, and the case of the Galapagos Islands appears to be paralleled by the distribution of the land shells of the Hawaiian Islands, and the extremely slightly marked local varieties of the fishes of certain lakes in Indiana, those of the *Littorina littorea*, and the flat fish of the New England coast; the problem as to the causes of their origin being still a matter of discussion.

In several very interesting chapters the author tells us about the relations between Darwin and Wallace; with the former originating the discovery of the principle of natural selection, and with the latter that of the survival of the fittest, both receiving their inspiration from a common source, Malthus' suggestive book on Population. As is well known, Darwin brooded over his work for twenty years, all this period observing and collecting facts, and experimenting and testing the truth of his views, while Wallace 'thought out almost the whole of his theory' in two hours, completing his essay in three evenings.

The publication of the joint article by Darwin and Wallace, in 1858, is memorable not only in the annals of science, but in the history of morals. For the nobility of spirit and generosity shown by both of the young ardent naturalists, the fact that, instead of leading to jealousy and bitterness, it formed the beginning of a life-long friendship, and of mutual confidence and esteem between the two, is most creditable to them as men and as scientists.

The historic meeting of the Linnean Society

when the joint essay was read appeared to have produced but little immediate effect. The first one to accept, in October, 1859, and by his own wide experience extend to variation in birds the principle of selection, was Canon Tristram.

The doctrine of the origin of species, as well as the principle of evolution in general, were ably supported by those intellectual giants Lyell, Hooker, Herbert Spencer, Huxley and Asa Gray, and the chapters in which the influence of these men on the acceptance and spread of Darwin's doctrines is described are not the least interesting in the book.

While the author is most sympathetic and appreciative, he becomes a grain narrow and provincial in his reference to Lamarck and his work, stating on p. 99 that the causes of evolution proposed by Lamarck are 'seriously disputed and it is possible that they may be ultimately abandoned.' On the contrary, we are now hearing, after they had laid *perdu* for a generation, a great deal about Lamarck's views as to the causes of variation, involving the influence of environment, of use and disuse, of isolation; even if we throw out use-inheritance, now in question, from a broad and catholic standpoint, we must concede to Lamarck the discovery of the fundamental causes of variation, and to Darwin and Wallace the discovery of the principles of competition and of selection.

A. S. PACKARD.

*La structure du protoplasma et les théories sur l'hérédité et les grands problèmes de la biologie générale.* PAR YVES DELAGE, Professeur a la Sorbonne. Paris, C. Reinwald et Cie., Libraires-éditeurs. 1895. Svo. Pp. 878.

Although Professor Delage's volume was published in 1895, it is perhaps not too late to say a few words to call the attention of the American scientific public to this valuable work. Professor Delage occupies quite a unique position through the series of elaborate critical compilations which he has made. These compilations have all been much more than a series of literary studies, having all been based to a considerable degree upon the examination by the author of the material involved in his subject. We need only refer here to the many-

volumed treatise upon zoology upon which Professor Delage is at present engaged, and which promises to become one of the monumental works of its kind. The present volume is divided into four principal parts. The first deals with the facts of observation, and discusses in a comprehensive manner the morphology and physiology of the cell, of the individual, of degeneration, sex, correlation of parts, death, etc., and, under the head of 'Race,' the phenomena of heredity, variation and the formation of species. The author has read very widely and understandingly, and his exposition of the facts which he has to present is extremely clear, so that this book easily occupies a first place among those that must be consulted upon the general phenomena of biology.

The second part discusses the special theories which have been advanced by various writers concerning the interpretation of the facts reported in the first part. We find under this head, for instance, the manifold views which have been advanced concerning the interpretation of the karyokinetic figures, of the isotropism of the ovum, of the germ plasm and of telogeny. The third part discusses the general theories, and here the author's industry is most advantageously revealed, although, as it was but natural to anticipate, the attention given to French writers preponderates somewhat over that accorded to the writers of other countries. Here we find a historical review of the theories which have been advanced concerning the soul, formative force and the vital force, and a review of the historic discussion between the Spermatists and the Ovatists. We would direct attention especially to the review of the various theories which have been put forward, beginning with Buffon and continued by Darwin and many others, according to which protoplasm is supposed to contain units of living matter of minute size, to which units the vital phenomena are ultimately to be referred. Those who are not familiar with the history of this subject will be perhaps surprised to find how many and varied these theories of the constitution of protoplasm have been, and how slight a basis of observation and fact any of them have had for a foundation. The method in which the author proceeds in these analyses is very excel-

lent. He gives first a summary of the particular theory, and then presents his critical observations upon the evidence and character of the theory itself, keeping thus his repertorial and judicial functions entirely distinct. The fourth part, which is the briefest, gives a review of the entire series of conceptions which seem to the author best founded and most coherent among themselves with regard to the manifold problems of heredity and general biology. The work closes with a valuable and very extensive bibliography. The author has carried out his purpose very successfully, and has produced a work which ought to be available for consultation in every biological laboratory.

CHARLES S. MINOT.

*Inorganic Chemistry according to the Periodic Law.* By F. P. VENABLE, University of North Carolina, and JAS. LEWIS HOWE, Washington and Lee University. Easton, Pa., The Chemical Publishing Co. 1898. Pp. 266. Price, \$1.50.

The authors of this text-book say in their preface: "The claim made in behalf of this book is that it takes the periodic system for its guiding principle throughout; \* \* \* some text-books give brief mention of the law; others introduce it partially while still clinging to the old systems." How far the authors have departed from the plan thus outlined is shown by the table of contents.

The introductory chapter occupies thirty one pages. Molecules and atoms are treated on the first page, the atomic theory on the second, the gas laws and Avogadro's hypothesis on the fifth and sixth; valency and electro-chemical phenomena on the sixteenth and seventeenth, the periodic law on the eighteenth, Mendelejeff's table and the reason for accepting it on the nineteenth. Absurd as it may seem to discuss these topics before the simplest chemical fact has been demonstrated, it is unavoidable if the general plan of the book is carried out. In the following chapters the elements (74 pp.), halides (11 pp.), oxides and sulphides (103 pp.), nitrides, carbides, silicides and alloys (5 pp.), are treated with reference to the periodic law.

It must be remembered that this is an elementary text-book for beginners. The begin-

ner, after his introductory dose of theory, studies hydrogen on page 32, oxygen on page 46, but does not take up the study of water till he has studied all other common elements. He then finds on page 114, among the hydrides, the hydrides of oxygen and the customary elementary chapter on water. If the authors had preferred to regard water as an oxide of hydrogen it would have been found 33 pages farther on. Another example: Sulphur is discussed on page 50, hydrogen sulphide on page 120, sulphuric acid on page 220, nearly at the end of the book!

The present reviewer belongs to that number of chemists to whom the authors might refer in the words of their preface, as 'clinging to the remnants of past systems while introducing the law partially;' the reviewer made daily and constant reference to the law in lecture and laboratory at a time when the only text-book extant in which it received more than brief mention was Lothar Meyer's 'Moderne Theorien der Chemie.' The reviewer ventures to mention this to show that he does not underrate the value of the periodic system as a help in elementary instruction; yet it seems to him that the authors have followed the system so slavishly that their book is most unsatisfactory. The authors claim in their preface that they have obtained excellent results. Doubtless skilled teachers obtain good results by any method applied with personal enthusiasm and backed by thorough knowledge. In this case the reviewer believes that the good results were due to the ability of the authors as teachers, not to the method used.

E. R.

*The Philippine Islands and Their People.* By PROFESSOR D. C. WORCESTER. New York, The Macmillan Company. 1898. 8vo. Pp. xix + 529. 2 maps and 60 illustrations. Price, \$4.00.

This volume is the outcome of two trips to the Philippine Islands. The first journey was made with Dr. Steere, in 1857-8, and work was prosecuted at that time for eleven months upon fifteen of the islands. In spite of many unpleasant experiences, the author and Dr. Bourns, who had been one of his companions

upon the first trip, decided in 1890 to make a much longer stay in the group of islands. Upon this latter occasion they were occupied for two years and eight months with the careful study of the birds and mammals of the more important islands of the group. The volume combines the story of the two expeditions and is rich in the experiences of the author, while, as he says himself, he avoids 'talking shop,' from the biological standpoint, and in this fact consists one of the charms of the book, as a great deal of scientific information is imparted at the same time that the story of the trip is told in a very pleasant style. It is not often that the capacity for accurate description and pleasant narrative are combined as they are in this case.

The first chapter is devoted to a brief historical summary of the events between Magellan's eventful voyage and the fall of Manila last August.

The author's experiences in the city of Manila are given in Chapter II., which is largely devoted to a description of that quaint city. His diplomatic struggles with Spanish red-tape will remind any one who has happened to visit the Island of Cuba of the similarity of conditions existing in this other colony of Spain, where only the power of royal authority invoked by an order from some superior source is the means of overcoming the complaint known as the 'itching palm' so common in all that country's colonies. The author speaks quite pointedly of the tendency to provoke nervous prostration, which is induced by the inevitable delays, and closes a brilliant attack upon the whole system with the remark of a Spanish official: "In your country, time is gold; here it is boiled rice." A good illustration of the old story of Spanish official plundering is given in the case of an officer who succeeded in making a fortune of fifty or sixty thousand dollars upon an annual salary of five hundred and forty dollars.

The total land area of the group is estimated by the author at 114,000 square miles, of which the Islands of Luzon and Mindanao make up more than one-half. The author gives a very good idea of the character of the natives of each island as he takes it up in the course of the volume. Probably the most interesting, because



the most novel, is his description of the Mangyans of Mindoro.

Of the eight to ten million inhabitants the author recognizes some eighty distinct tribes; Negritos, Mohammedan Malays, pagan Malays and civilized Malays are, however, the principal groups under which they can all be classified. The Negritos occupy the bottom of the scale, and apparently are incapable of civilization. They are, however, a disappearing factor and can be neglected. The Mohammedan Malays, or Moros, however, present a very different and much more difficult problem. Any nation hoping to get on peacefully with them will find it necessary to let their religion strictly alone. They will require to be ruled with absolute justice, but with relentless firmness, and must be held in check with a strong hand for a very long time before they can be brought into anything like sympathy with our customs. Of the pagan Malays the larger proportion are harmless and docile, but there are others hostile to the whites, with the best of reasons for their dislike. They are generally, however, made out much worse than they really are. The author suggests that the best use to be made of the warlike hill-tribes is to turn them into soldiers, as has been done in India.

The only problem presented by the wild Malays is their civilization.

Where there is so much that is interesting to draw from, it is difficult to choose, but a few examples might be given, which will illustrate the state of society upon the Islands. The reply of a certain native to his padre covers the ground quite completely. This unregenerate heathen said that if he became a Christian it would cost money to be baptized, to live, to marry, to die and to be buried. In his existing state some of these more or less necessary operations cost him nothing, and he could see no advantages to be derived from embracing Christianity commensurate with the increased expense. The author's observations led him to believe that the morals of the natives improve as the square of the distance from churches and other so-called civilizing influences. The author tells a great many interesting stories, which are intensely amusing, and none of them lose anything from his method of

presentation. The pages, for instance, which refer to his experience on the Island of Siquijor are unique. The story of the padre and the civet cat would do credit to Mark Twain. One can imagine better than describe the sensations of the author when, after innocently whistling one of our popular-ditties, he awoke one morning to find that the band master had reduced the song to a proper score, and at the head of a dignified religious procession was marching to the cathedral with his band playing this tune at their utmost lung capacity; and now 'Johnny get your gun' has been added to the repertoire of the sacred music of the island.

Some idea, perhaps, may be obtained of the primitive condition of the natives of the islands from their customs. They seem to prefer their meat in the condition of Charles Lamb's cheese, ready to be led if you could tie a string to it; and one is not inclined to believe that their use of the white grubs from the Sago palm as confectionery will be universally adopted.

Ex-President Cleveland will probably be interested in the account of his canonization, as given on page 490.

The author does not find the climate to contain as many of the elements ascribed to Paradise as some of his predecessors. In fact, his own observations and the summary given of the thirteen years' series of observations, made at Manila, would lead to the inference that the climate was rather severe. This might have been expected from the tropical location of the Islands. The further complication of malaria and fevers of all sorts upon the lowlands make great portions of the Islands very unattractive as places of residence.

The important questions concerning the future of the Philippines naturally arise from the character of the five million civilized natives. These belong, for the most part, to three distinct tribes, the Tagalogs, the Ilicanos and Visayans. They have good and bad characteristics: for example; they are unfaithful to obligations of all sorts; they are refractory towards mental improvement, and they are confirmed liars, even without excuse, unless it should happen to be the æsthetic satisfaction of the use of their talents in that line. They

are said to lack originality, but this is perfectly natural under the conditions in which they have been forced to live. They are almost hopelessly indolent, but no one, not even a white man, could work there as he would in a temperate region and live. He has many good qualities, however, to counterbalance these defects in his character. His open-handed and cheerful hospitality is much in his favor. He is cleanly, both with regard to his person and his surroundings. His houses and family are well regulated. He is patient and forbearing, but when he does get angry becomes a perfect maniac. He is a kind father and dutiful son. He is genial and sociable among his fellows, and is naturally fearless.

With all these good qualities they seem, however, to be absolutely unfit for self-government, and probably their lack of education is the main difficulty in the way of their realizing this important object. They appear to be 'big children who must be treated like little ones,' but as they are naturally law-abiding and peace-loving there is some hope of them.

The natural resources and the conditions governing their development are dealt with in the appendix.

WILLIAM LIBBEY.

#### GENERAL.

AFTER four years a new edition of M. Ch. Féré's *La famille neuropathique* (Alcan) has been called for, and the author has used the occasion not only to revise the work throughout, but also to add much new material. A chapter is now devoted to the heredity of tumors; the discussion of monstrosities and their experimental production is enlarged as the result of new contributions, and the abundant recent literature on physical and mental degeneration is incorporated. The heredity of bodily diseases and malformations is a subject sufficiently difficult, while in the case of mental degeneration there is at present almost complete chaos. When M. Féré discusses the hereditary transmission of vice, crime and even functional disturbances of the nervous system it is impossible to be sure that what he regards as hereditary is not entirely due to environment. When he says we must spread precise ideas of the causes

of degeneration, and then proceeds to give the five causes, at least half of them are extremely doubtful. It is not even certain that degeneration does obtain in modern society. M. Féré's review, is, however, on the whole objective, and is made especially valuable by the ample references to the literature. It appears from the index of names that more than 1200 separate authors are quoted, and full bibliographical details are supplied.

PROFESSOR KARL GROOS's work on 'The Play of Animals' has been translated into excellent English by Miss Elizabeth L. Baldwin and published by the Appletons. As the editor, Professor J. Mark Baldwin, says in his preface, the volume is a contribution to three departments of enquiry—philosophical biology, comparative psychology and the genesis of art. Being thus of interest to many students, the English version will prove most useful. It is not necessary to give an account of the contents of the book, as the German edition was the occasion of a thorough critical review by Professor Baldwin (Vol. V., pp. 347-52). Indeed, then was first adequately signalized the importance of Professor Groos's work. The promised companion volume on the play of children is awaited with much interest.

WE are glad to call attention to the second edition of Dr. Verworn's *General Physiology*, the original edition of which has already been reviewed in these columns (Vol. II., pp. 557-8). The second edition shows many improvements upon the first, and many of the subjects which were somewhat scantily dealt with in the earlier edition are now treated more fully; but the general plan and execution of the work remains closely similar to that of the original edition, so that we hold it to be unnecessary to do more than again commend the work to the attention of American biologists, and to express the hope that general physiology, in the sense of the science of the functions of the cell, may receive in this country a much greater attention than has hitherto been the case. For this reason the translation of the work by Professor F. S. Lee, of Columbia University, announced for early publication by The Macmillan Co., will be particularly welcome.

## SCIENTIFIC JOURNALS.

The *Astrophysical Journal* for November opens with an article on the probable range of temperature on the moon by Dr. Frank W. Very, in which the subject is taken up from its experimental side. There are short articles by Dr. J. Hartman on an interpolation formula for the prismatic spectrum; by Professor P. Tacchini on solar observations made at the Observatory of the Roman College, and by Professor E. E. Barnard on the great Nebula of Andromeda. More than half of the number is devoted to abstracts of papers read at the second Conference of Astronomers and Astrophysicists.

THE November number of the *American Geologist* contains the following articles:

Geographical Phenomena resulting from the Surface Tension of Water: GEORGE E. LADD.

The Occurrence of Copper and Lead in the San Andreas and Caballo Mountains: C. L. HERRICK.

Giants' Kettles near Christiania and in Lucerne: WARREN UPHAM.

Origin of the Archean Igneous Rocks: N. H. WINCHELL.

Glacial Theories—Cosmical and Terrestrial: E. W. CLAYPOLE.

Intraformational Conglomerates in the Galena Series: F. W. SARDESON.

Editorial Comment—Drygalski's Glacial Studies in Greenland.

WE note with much regret the discontinuation of *Science Progress*, after the publication of seven volumes, first as a monthly and during the past two years as a quarterly review of current scientific investigation. It has been conducted by Sir Henry Burdett and edited by J. Bretland Farmer, with the cooperation of a strong editorial committee, the contributions always maintaining a high standard of excellence. The notice of discontinuation does not hesitate to emphasize the merits of the journal, remarking as it does: "*Science Progress* is admittedly the best scientific serial publication which has been issued from the English press, and it is disappointing to find that scientists generally, whilst expressing appreciation of the publication, have failed to support it by becoming subscribers. For nearly five years, relying upon its excellence, the publishers have continued the publication. The result shows, how-

ever, that at the present time scientists will not subscribe in sufficient numbers to enable a publication of the high type of *Science Progress* to be financially successful." The real difficulty has, however, been that all the sciences have been included in the scope of a single journal, and each science has often been treated in a manner too technical to be interesting or even intelligible to those who are not special students of the science. But it is unfortunate that public spirit and enlightened self-interest are not sufficiently developed to support a journal the discontinuation of which is a serious loss to science.

## SOCIETIES AND ACADEMIES.

## NATIONAL ACADEMY OF SCIENCES.

THE Academy held its autumn meeting for the reading of scientific papers on November 15th. Twenty-seven members were present. The following papers were read:

I. Anatomy of *Nautilus pompilius*, W. K. BROOKS and L. E. GRIFFIN. (Not read.)

II. On solid solutions of colloidal glass, C. BARUS.

III. Three phases of vertebrate development, CHARLES S. MINOT.

IV. Notes on mammalian embryology, CHARLES S. MINOT.

V. The influence of alcohol and alcoholic fluids on digestion, R. H. CHITTENDEN.

VI. On the conditions modifying the excretion of kynurenic acid, LAFAYETTE B. MENDEL. (By invitation.)

VII. Perturbations of Minerva, with a preliminary determination of its orbit, W. S. EICHELBERGER, presented by SIMON NEWCOMB. (Read by title.)

VIII. On a series of native skulls from New Guinea, O. C. MARSH.

IX. On the reputed prefrontal bones in recent mammals, O. C. MARSH.

X. Sodium tungstate as a retainer for boric acid, F. A. GOOCH and LOUIS CLEVELAND JONES.

XI. The ammonium-magnesium phosphate of analysis, F. A. GOOCH and MARTHA AUSTIN.

XII. The chemical composition of Tourmaline, S. L. PENFIELD. (By Invitation.)

XIII. On the nature and origin of the marine fauna of Bermuda, A. E. VERRILL.

XIV. On the ability possessed by certain animals to recover after complete freezing, A. E. VERRILL.

XV. Further researches in the two isomeric chlorides of orthosulphobenzoic acid: A study in tautomerism, IRA REISEN.



XVI. On the brecciated fossil marble from Kishin, Japan, O. C. MARSH.

XVII. On some rare antiquities from Mexico, O. C. MARSH.

XVIII. Report upon work in spectrum analysis carried on by help of the Bache Fund, H. A. ROWLAND.

XIX. Observations on the Zeeman effect with the echelonspectroscope, A. A. MICHELSON.

NEW YORK SECTION OF THE AMERICAN CHEMICAL SOCIETY.

THE November meeting of the New York Section of the American Chemical Society was held on Friday evening, the 11th, at the College of the City of New York, and was of unusual interest.

The first paper was descriptive of a 'New Apparatus for the Determination of Volume,' by Dr. C. F. McKenna. The instrument is designed to obviate the defects in other forms, such as those of Schumann or Candlot in respect to accuracy of readings, leakage of ground-glass joints, etc. In the apparatus proposed the powdered solid is introduced through one tube, and the reading is made on another, so slender that tenths of a cubic centimeter can be easily read and hundredths quite accurately estimated. This avoids the difficulty in reading which frequently occurs where the powdered substance is introduced through the same tube on which the readings are made.

Professor Venable, of the University of North Carolina, reviewed the 'Present Status of the Periodic Law,' exhibiting tables and calling attention to the imperfect knowledge of the elements as the cause of much, if not all, the difficulty in arranging the elements in satisfactory groups under Mendelejeff's periodic or natural system.

Mention was made of the peculiar position of hydrogen, and the light which may be thrown on it if the various new gases recently discovered shall fall into a group of which hydrogen is at present the only known member. The question as to the elemental character of the accepted elements was also touched upon in connection with the seven coucordant groups. Speaking of the want of accuracy in many of the determinations of atomic weight, Professor Venable thought it quite possible that the frac-

tional parts of these values might be of great importance, which would, of course, emphasize the need for accuracy in their determination.

Mr. R. H. Atwater read a paper on 'Chemical Glassware,' in which he took up the questions relating to the ordinary forms of glassware used in the chemical laboratory, referring to the proper form of necks, lips and stoppers of reagent bottles, engraved, etched, molded and sandblast labels, the best method of protecting the lips and mouths from dust, etc.

Referring to the nature and properties of glass, he said that glass is not usually a true salt, but a compound of true crystalline salts with an indefinite proportion of uncrystalline glass or flux. Soda glass is hygroscopic, therefore lead glass is much more satisfactory for electrical non-conductors.

In at least one factory in this country polarized light is used for testing the character of the annealing.

In conclusion, Mr. Atwater said that the American market for chemical glassware is the best in the world, and would reward the home manufacturers for making ware of as good a quality as that made abroad.

In the discussion of the paper Dr. Squibb recommended reagent bottles with loose caps over the stopper to keep away dust, and advised inverting bottles with 'set stoppers' in water over night.

A communication from the General Secretary was then read stating that the invitation from the Section to the Society at large to hold the winter meeting in New York had been accepted by the Council, and the date fixed for December 27th.

DURAND WOODMAN,  
*Secretary.*

CHEMICAL SOCIETY OF WASHINGTON.

THE regular monthly meeting was held on October 13, 1898.

The first paper of the evening was read by Dr. H. W. Wiley, and was entitled 'Preliminary Report on the Vienna Congress of Applied Chemistry.' Dr. Wiley gave an interesting account of the proceedings of the Third International Congress of Applied Chemistry. Some of the more important papers which were pre-

sented were mentioned. The two most notable papers were those on the synthesis of albumen, by Lillienfeld, and on fermentation without cells, by Buchner. The entertainments afforded to visiting members were also described. A full report will soon be published in the *Journal of the American Chemical Society*.

The second paper of the evening was read by Dr. H. C. Boltou, and was entitled 'Chemical Bibliography.' The author described, in an interesting manner, the methods pursued by him in the collection of bibliographic references and related some of his experiences in Europe.

Mr. Tassin called the attention of the Society to a new solution for determining high specific gravities, which consists of a solution of acetylene tetra-bromide in benzol or toluol. It has the advantage of being stable, cheap and easily made, has a high refractive index and does not decompose with metallic oxides or metals.

WILLIAM H. KRUG,  
*Secretary.*

HARVARD UNIVERSITY: STUDENTS' GEOLOGICAL CLUB, OCTOBER 25, 1898.

MR. J. M. BOUTWELL gave a paper on 'Nipissing Pass, An Ancient Outlet of the Great Lakes.' After briefly reviewing the post-glacial history of the great lakes, he described the results of a day's study of the region between Trout Lake and Nipissing Lake. Along the southern slope of the heights to the north, and overlooking the low, swampy divide between these lakes, are well developed and only slightly dissected bars, spits, terraces, and boulder-strewn beaches. These correlate with similar features, observed by Taylor, Gilbert, Spencer and others, about the upper Great Lakes, and mark the position, character, and recency of one of their post-glacial outlets.

*Geological Conference, November 1, 1898.* In a communication entitled 'Minerals of the Ural Mountains,' Dr. Charles Palache described the localities, occurrences, and important features of the ores, gems and rare minerals of that region. Native gold occurs in paying quantities in quartz veins which traverse the granite, syenite, metamorphic rocks and sediments older than Devonian, and also in places, which are mainly in streams that drain

eastward. Platinum is found locally in association with serpentine and chrome-iron. Chalcopyrite occurs in limited areas with an altered surface zone of malacite. Along the axis of the mountains are valuable deposits of magnetite that are associated with porphyry dikes. Siderite, with its alteration products, and manganese oxide are found as beds in the Devonian. Beryl, topaz and tourmaline occur only in pegmatites, which cut the granite, gneiss, and metamorphic rocks of the central Urals. Both are found in large, perfect crystals of the blue variety, and are used as gems. In addition to the valuable specimens of epidote, garnet, vesuvianite, perovskite, ilmenite and massive rhodentite, which occur at the contact of basic eruptives with Paleozoic limestone, this region affords several minerals that are unknown elsewhere.

Mr. J. B. Woodworth described a recent visit to 'The Glaciers of Chamonix, France.' Two phenomena, found repeatedly, were a 'shingling' arrangement of boulders in the lower, lateral moraines, due to a shoving method of deposition by the ice; and a manifest overthrusting of the upper layers of the ice, in the manner observed by Chamberlin in certain Greenland glaciers. At a point in the Glacier d'Argentière a sharp, overthrust fault showed characteristic, drag features. Current photographs fail to do justice to the height of the Alpine moraines.

J. M. BOUTWELL,  
*Recording Secretary.*

#### NEW BOOKS.

*Elementary Text-book of Botany.* SYDNEY H. VINES. London, Swan, Sonnenschein & Co., Ltd.; New York, The Macmillan Company. 1898. Pp. xv+611. \$2.25.

*The Metric System of Weights and Measures Used by the Hartford Steam Boiler-Inspection Company, Hartford, Conn.* 1898. Pp. 196. \$1.25.

*Leçons de chimie physique.* J. H. VAN'T HOFF. Translated from the German by M. CORVISY. Paris, A. Hermann. 1898. Pp. 263. 10 fr.

*The Living Organism, an Introduction to the Problems of Biology.* ALFRED EARL. New York and London, The Macmillan Company. 1898. Pp. xiii+271. \$1.75.

# SCIENCE

EDITORIAL COMMITTEE: S. NEWCOMB, Mathematics; R. S. WOODWARD, Mechanics; E. C. PICKERING, Astronomy; T. C. MENDENHALL, Physics; R. H. THURSTON, Engineering; IRA REMSEN, Chemistry; J. LE CONTE, Geology; W. M. DAVIS, Physiography; O. C. MARSH, Paleontology; W. K. BROOKS, C. HART MERRIAM, Zoology; S. H. SCUDDER, Entomology; C. E. BESSEY, N. L. BRITTON, Botany; HENRY F. OSBORN, General Biology; C. S. MINOT, Embryology, Histology; H. P. BOWDITCH, Physiology; J. S. BILLINGS, Hygiene; J. MCKEEN CATTELL, Psychology; DANIEL G. BRINTON, J. W. POWELL, Anthropology.

FRIDAY, DECEMBER 2, 1898.

THE ASSOCIATION OF AMERICAN AGRICULTURAL COLLEGES AND EXPERIMENT STATIONS.

## CONTENTS:

<i>The Association of American Agricultural Colleges and Experiment Stations:</i> A. C. TRUE.....	761
<i>Thermal Efficiency of Steam Engines:</i> PROFESSOR R. H. THURSTON.....	764
<i>The Kinetic Theory of Gases and Some of its Consequences:</i> PROFESSOR WILLIAM RAMSAY.....	768
<i>On Some Analogies between the Physiological Effects of Lack of Oxygen, High Temperature and Certain Poisons:</i> DR. WILLIAM ZOETHOUT.....	776
<i>Leidy's Genus Ouramaba:</i> PROFESSOR WILLIAM L. POTEAT.....	778
<i>New Names for Spermophilus breviceaudus, Canis patidus and Sorex caudatus Merriam:</i> DR. C. HART MERRIAM; <i>for Microtus insularis Bailey:</i> VERNON BAILEY; <i>for Sciurus alpinus quercinus Nelson:</i> E. W. NELSON.....	782
<i>Professor James Ingraham Peck:</i> PROFESSOR H. C. BUMPUS.....	783
<i>Notes on Inorganic Chemistry:</i> J. L. H.....	783
<i>Current Notes on Meteorology:—</i> <i>August Hot Wave in California; Monthly Weather Review; Notes:</i> R. DEC. WARD.....	785
<i>Botanical Notes:—</i> <i>Some More Atrocious Botany; Western Weeds; The Economic Grasses of the United States</i> .....	785
<i>Current Notes on Anthropology:—</i> <i>Influence of Sex on Crime; The Progress of Anthropology; A Neolithic Lady:</i> PROFESSOR D. G. BRINTON.....	787
<i>Scientific Notes and News</i> .....	788
<i>University and Educational News</i> .....	791
<i>Discussion and Correspondence:—</i> <i>Shall the International Equivalent of 'Anlage' be Primordium or Proton:</i> PROFESSOR BUET G. WILDER. <i>Post-glacial Connecticut:</i> MARK S. W. JEFFERSON.....	793
<i>Scientific Literature:—</i> <i>Helmholtz's Handbuch der physiologischen Optik:</i> PROF. J. MCKEEN CATTELL. <i>Atkinson's Elementary Botany:</i> PROF. CONWAY MACMILLAN.....	794
<i>Scientific Journals</i> .....	798
<i>Societies and Academies:—</i> <i>Boston Society of Natural History:</i> SAMUEL HENSHAW. <i>Biological Society of Washington:</i> F. A. LUCAS. <i>Geological Club and Conference of Harvard University:</i> J. M. BOUTWELL.....	799
<i>New Books</i> .....	800

THE Association of American Agricultural Colleges and Experiment Stations, which held its twelfth annual convention at Washington, D. C., November 15th–17th, includes in its membership many of the State universities and scientific institutions in which instruction in many technical lines besides agriculture is carried on. It is a delegate body, each college being represented by its president or other officer, and each agricultural experiment station by its director or some other member of its expert staff. The institutions represented in this Association employ over 1,500 persons in their faculties, who are giving instruction to about 30,000 students. These institutions have over \$50,000,000 in permanent endowments, buildings and equipment, and an annual revenue of nearly \$6,000,000, of which more than \$2,000,000 is derived from funds granted by the United States. Besides the work of instruction, they are carrying on original research in different directions. This is especially true in many scientific lines relating to agriculture, over a million dollars being spent for this purpose annually. There are now pending in Congress propositions to establish, in connection with these institutions, experiment stations for investigations in mechanic arts and naval engineering, for which some of



the colleges already have considerable facilities. The convention just closed was attended by delegates from every part of the country, and was regarded as a very successful meeting.

The annual address of the President of the Association, Dr. H. C. White, President of the Georgia State College of Agriculture and Mechanic Arts, was an unusually eloquent and able presentation of the breadth and strength of the education given along scientific and industrial lines in many of our land-grant colleges. He showed how 'the scholar' was the product of such education just as truly as of institutions built on classical foundations. He also pointed out that these institutions, which derive their support so largely from the United States Treasury, together constitute a great national university. The address thus furnished an appropriate introduction to the discussion of one of the most important topics taken up by the convention. There is a strong feeling among these institutions that the facilities for graduate study which are embraced in the great libraries, museums and scientific laboratories of the Government at Washington should be open to their students. A year ago the Association appointed a committee "to devise a plan whereby graduate students of the land-grant and other colleges may have access to, and the use of, the Congressional Library and the collections in the Smithsonian Institution, the National Museum and the scientific bureaus of the various Departments, at Washington, of the United States Government, for the purpose of study and research." This committee consisted of President Northrop, of the University of Minnesota; Secretary Cope, of Ohio State University; President Buckham, of the University of Vermont; President Ellis, of the State Agricultural College of Colorado; Chancellor McLean, of the University of Nebraska; President J. H. Washburn,

of the Rhode Island College of Agriculture and Mechanic Arts. The committee, after a careful personal examination of the conditions in the different Departments at Washington, presented a report at this meeting of the Association, which included a recommendation that Congress be asked to pass the necessary legislation to organize a bureau of graduate study, preferably in the Smithsonian Institution, through which students from American colleges may have open to them the vast accumulations of scientific and other material for study existing at the National Capital. It was urged that this could be done at comparatively little expense, and that the high standing of the Smithsonian Institution in the scientific world, and its conservative organization, would enable it to carry on this work in a most creditable and satisfactory manner. The report was heartily endorsed by the Association, and the committee was instructed to make every effort to secure the necessary legislation at an early day. In this connection it may be interesting to note that it is the expressed intention of the Secretary of Agriculture to include in his forthcoming annual report a recommendation that the scientific divisions of the Department be open to a limited number of graduate students who will be admitted as the result of a competitive test, probably under the Civil Service Commission, and who may in some cases receive limited compensation for such services as they may render the Department in connection with their researches.

Another topic which attracted great interest at the meeting was the problem of more thoroughly organizing the military instruction which, under the law, is given in the institutions included in the Association. An able paper on this subject was read by President C. W. Dabney, Jr., of the University of Tennessee. In this paper, which received the hearty endorsement of the Association,

Dr. Dabney urged that the Government take steps to recognize these institutions more fully as agencies for the training of the officers who will be needed for our increased military establishment. A considerable number of the graduates of these institutions served with distinction in the war just closed, and there is good reason to believe that in the reorganization of our volunteer army it will be necessary to look to these institutions very largely for the trained material needed to put the volunteer army on a more efficient basis.

A notable paper was read by President A. W. Harris, of the University of Maine, on the relations of the churches to State colleges and universities. The author thought the different denominations should make some special provision at these colleges for students of their membership by building dormitories and chapels, and by organizing special courses of instruction in the immediate vicinity of the State college. In the discussion which followed, it was generally held that the churches might safely be left to promote their own interests through the agencies for church activity which are common in American communities.

The committee on methods of teaching agriculture presented its third report of progress, in which it gave a syllabus for a course of instruction in agronomy (plant production). The committee on indexing agricultural literature presented a library classification of agriculture (in its narrower technical sense) devised by Mr. W. P. Cutter, Librarian of the Department of Agriculture. The committee appointed by this Association to cooperate with the committee from the Association of Official Agricultural Chemists on uniformity in fertilizer laws brought in a schedule of twenty points, which both committees agreed were suitable for incorporation in the laws of the several States. By a very decisive vote the Asso-

ciation rejected propositions for the amendment of the constitution of the Association which looked to the abolition of the sections or their reduction in number. Meetings of all the sections were held during this convention and a number of interesting papers were read. Among the subjects most earnestly discussed were the inspection of nursery stock for the repression of insect and fungus enemies, and horticultural nomenclature.

The following officers of the Association were elected for the ensuing year: President, H. P. Armsby, Director of the Pennsylvania State College Agricultural Experiment Station; First Vice-President, J. E. Stubbs, President of the Nevada State University; Second Vice-President, C. S. Murkland, President of the New Hampshire College of Agriculture and the Mechanic Arts; Third Vice-President, J. L. Snyder, President of the Michigan Agricultural College; Fourth Vice-President, P. H. Moll, Director of the Agricultural Experiment Station of the Agricultural and Mechanical College of Alabama; Fifth Vice-President, F. P. Anderson, Professor of Mechanical Engineering of the Agricultural and Mechanical College of Kentucky; Secretary and Treasurer, E. B. Voorhees, Director of the New Jersey Agricultural Experiment Stations; Bibliographer, A. C. True, Director of the Office of Experiment Stations of the U. S. Department of Agriculture; Executive Committee: H. H. Goodell, President of Massachusetts Agricultural College; Alexis Cope, Secretary of Ohio State University; J. H. Washburn, President of the Rhode Island College of Agriculture and Mechanic Arts; W. M. Liggett, Director of the Agricultural Experiment Station of the University of Minnesota.

The following is a list of the papers read before the sections:

Section on College Work: 'Some Recent Changes in the Theory of Education,' E. A. Bryan, President

of the Washington Agricultural College and School of Science. 'Relations of the Churches to State Colleges and Universities,' A. W. Harris, President of the University of Maine.

Section on Mechanic Arts: 'What Preparatory Work should be Required to enter Four-Year Engineering Degree Courses,' O. L. Waller, Professor of Mathematics and Civil Engineering of the Washington Agricultural College and School of Science. 'Engineering Standard in Land-Grant Colleges,' W. H. Williams, Professor of Mechanical Engineering and Mathematics of the Montana College of Agriculture and Mechanic Arts.

Section on Horticulture and Botany: 'Laboratory Methods in Teaching Horticulture,' L. C. Corbett, Professor of Horticulture of the West Virginia University. 'Relation of Rainfall to Fungus Diseases,' B. D. Halsted, Professor of Botany and Horticulture of Rutgers Scientific School. 'Testing of Fruits by the Experiment Stations,' S. M. Emery, Director of the Montana Agricultural Experiment Station. 'Technical Training in Teaching Horticulture,' S. B. Green, Professor of Horticulture of the University of Minnesota. 'Preliminary Report of the Committee for the Testing of Races of Peaches,' R. H. Price, Professor of Horticulture, Botany and Entomology of the State Agricultural and Mechanical College of Texas.

Section on Entomology: 'Entomology in Agricultural Colleges,' E. E. Faville, Professor of Horticulture and Entomology of Kansas State Agricultural College; S. A. Forbes, Professor of Zoology of the University of Illinois; H. Osborn, Professor of Zoology and Entomology of Iowa State College of Agriculture and Mechanic Arts; L. Bruner, Professor of Entomology of the University of Nebraska. 'A Fungus Disease of the San José Scale,' V. H. Lowe, Entomologist of the New York Agricultural Experiment Station. 'The Teaching Function of the Station Worker,' J. B. Smith, Professor of Entomology of Rutgers Scientific School. 'The Influence of Nature-Studies in Schools upon the Biology of the College Curriculum,' C. M. Weed, Professor of Zoology and Entomology of New Hampshire College of Agriculture and Mechanic Arts.

Section on Agriculture and Chemistry: 'Clover, Phosphates, and Wheat in Ohio,' W. I. Chamberlin, of Ohio. 'Productivity as affected by Tillage,' L. P. Roberts, Director of Cornell University Agricultural Experiment Station. 'The Maintenance Ration of Cattle,' H. P. Armsby, Director of the Pennsylvania State College Agricultural Experiment Station. 'The Mission of the Agricultural and Mechanical Colleges and Stations from the Standpoint of the Agriculturist,' J. S. Newman, Professor of Agriculture of Clemson Agricultural College. 'Upon the

Possibilities of drawing Erroneous Conclusions from Plant Soil Tests designed as Guides to the Economical Manurial Treatment of Soils, and to serve as a Basis for the Development of Reliable Chemical Methods for ascertaining their Requirements,' H. J. Wheeler, Chemist of the Rhode Island Agricultural Experiment Station. 'The Significance of Stock-Feeding Experiments,' C. F. Curtiss, Director of the Iowa Agricultural Experiment Station. 'Notes on Butter Tests of Cows,' M. A. Scovell, Director of the Kentucky Agricultural Experiment Station.

A. C. TRUE.

WASHINGTON, D. C.  
November 22, 1898.

#### THE THERMAL EFFICIENCY OF STEAM-ENGINES.

A COMMITTEE of the British Institution of Civil Engineers, composed of recognized authorities, has recently made a report, now published by the Institution, on the above subject, in which is proposed a standard and consistent scientific scheme for the treatment of thermal and thermodynamic quantities in the discussion of the experimentally determined efficiencies of the steam-engine. It is so important a document that we give space to a somewhat liberal abstract and summary of the conclusions of the committee.\*

An introduction by the Secretary, Captain H. R. Sankey, gives a technical definition of the 'steam-plant' and points out the differences, the wastes, which distinguish the ideal and the real heat-engines. These differences are illustrated by an exceedingly interesting and helpful diagram in which the energy-flow is traced from its source in the fire-box of the boiler through the boiler and its contents of steam and water, on the one hand, for use in the engine, and, on the other hand, to the chimney as a waste. It exhibits the methods, extent and character of the wastes of thermal, of dynamic and of thermodynamic

\* Report of the Committee appointed to consider and report to the Council upon the subject of the Definition of a Standard of Thermal Efficiency.—London, Published by the Institution, 1898.



phenomena in the engine as well as at the boiler, and exemplifies the case by making the diagram a correct measure, drawn to scale, of the performance of a famous steam pumping engine.

All the required data for exhibition of this flow of the energies through a heat-engine are secured and recorded in every well conducted and complete engine-trial, and ample data are now available for its illustration. One of the best of recent reports upon the performance of the exceptionally economical Leavitt engine at the Louisville, Ky., water works has been diagrammed in this manner by Captain Sankey, to make clearly understood the principles and the facts involved in the discussion of the 'thermal efficiency of steam-engines,' by this committee of the British Institution of Civil Engineers. This diagram is here reproduced, from that report, published as above. In this instance, every known precaution against waste of heat has been taken, and all the conditions, thermal, thermodynamic and dynamic, are in unusual degree favorable to a high resultant efficiency. The case is, therefore, a very exceptionally good illustration of thermodynamic action, and the wastes are much smaller than are commonly observed in the operation of even good classes of steam-engine.

"The broad river of heat, generated by the burning coal on the grate, is shown flowing to and through every part of the apparatus, losing by radiation at every step, and finally emerging at the chimney, in a flow of heated air and gases, and at the condenser, in the circulating water discharged, and at the engine-shaft as useful work." All of this broad river of heat arises from a source within the fuel bed, flows through its delta of narrower channels, mainly to waste, and it all finally emerges into the great sea of heat, the external atmosphere, as thermal energy; even

the useful work being sooner or later retransformed into heat by friction, whether of engine or of work performed by the machine. Were our diagram to give the further history of these flows of energy it would show a cycle in which the external currents circulate from the engine into the atmosphere, into potential forms, once more, by retransformation into the stored energy of chemical affinities, through the ever-active influence of vegetation, later to be possibly again employed in other heat-engine cycles, when once more resurrected as potential energy of fuel.\*

The diagram here reproduced is drawn to a scale, and quantities of heat, and temperatures as well, are shown at each step in the progress of the heat flow, from fuel to outer atmosphere and to the drainage channels of the country. The following verbal description may properly accompany the graphic story:

At the start, 183,600 B. T. U. per minute is the measure of the energy liberated in active form from its original, potential, condition in the fuel. Of this energy, 131,700 B. T. U. pass into the water and steam and are there stored as thermal energy, available for thermodynamic operations; 41,900 go toward chimney and economizer; 10,000 flow out of the system, as waste, through condition and radiation in the flow between boiler and economizer, 5,000 more at the economizer, and 15,750 are taken into the feed-water within the economizer and thus utilized. The balance, 20,150, get through the economizer and flow up chimney and thus into the outer air and are lost to the thermodynamic system.

The economizer receives 5,450 B. T. U. from the feed-water coming from the engine and 15,750 from the furnace-gases;

\* For original data of the case here taken, see *Trans. Am. Society Mechanical Engineers*, Vol. XVI., *Engineering News*, December 13, 1894. *Proc. Brit. Inst. C. E.*, 1898.

sending the total, 21,200, toward the boiler ; for use there ; losing, however, 250, *en route*, and giving up the remainder, 20,950, together with the heat of jacket-water, joining the stream at the boiler, to reduce the demand for and cost of fuel, by raising the temperature of the water to be converted into steam.

The flow to the engine from the boiler

$27,260 / 142,150 = 0.15$ , fifteen per cent. This is called the 'Thermal Efficiency of the Engine,' perhaps more correctly *Thermodynamic Efficiency of the Engine*. The indicated power is reported as 643 H. P. and the demand for heat at the piston is thus 221 B. T. U. per I. H. P. per minute.

Engine-friction absorbs work to the equivalent of 1,870 B. T. U. per minute,

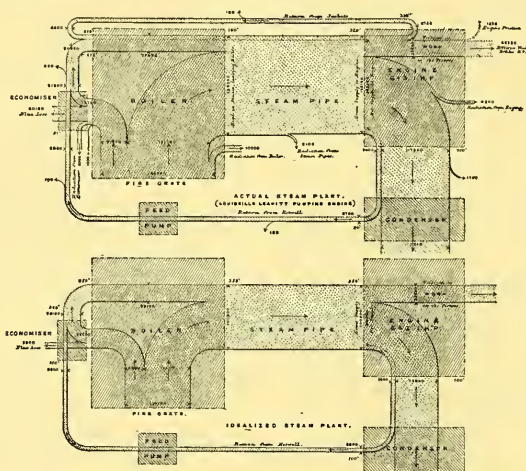

LOSSES AND TRANSFERS OF HEAT IN STEAM-POWER PLANTS.

begins with a stock of 169,350 B. T. U. per minute, but 3,100 are lost on the way by conduction and radiation and by leakage from the steam pipes, and the engine actually receives a balance of 156,150 B. T. U. per minute. Of this, 7,400 go back in the feed-water and 6,600 from the jackets, making the net supply 142,150 B. T. U. per minute.

Of this net supply, only 27,260 are reported to have been transformed into mechanical energy, to flow through the engine and perform work, useful or other. The efficiency of this operation is, therefore, but

and this gives 25,390 B. T. U. as the equivalent of the net, usefully applied, work of the engine, and this gives us 237 B. T. U. per minute as the consumption of energy per D. H. P., a measure of the 'brake efficiency,' as it is sometimes called.

The second of the two figures here represented, on the lower portion of the plate, illustrates the ideal case, the ideal steam-engine delivering the same quantity of 'indicated' power, and differing from the real engine by operating in the 'Rankine Cycle,' and in exhibiting no wastes by clearance or friction, conduction or radiation—

a purely thermodynamic case. At the boiler, also, there are no losses by conduction or radiation and the flue-gases are reduced to the temperature of the steam in the boiler before discharge.

Of the total heat developed in the furnace, now only 104,200 B. T. U., the large proportion, 31,400, are still wasted by way of the chimney, since the gases must be sent out at least as hot as the boiler-steam. The quantity sent to the engine is 72,800, to which is added the saved heat from the economizer, here also assumed to be employed, 28,100 B. T. U. The engine receives, thus, a total of 100,900 B. T. U. per minute, of which 5,600 is returned by way of the feed-pipe, giving a net supply of 93,300 for the thermodynamic cycle. This amounts to 148 B. T. U. per I. H. P. per minute, equivalent to an efficiency of 0.285. The ideal thus demands but 0.67, two-thirds the heat-supply of the actual engine.

This graphical analysis has special interest in connection with the employment of the engine-trial data in the calorimetric analysis of Hirn for detection and measurement of thermodynamic and other defects of the actual engine cycle. Where the jacket is employed, it is to be understood that the process of the flow of heat from the jacket-steam into the wall of the engine-cylinder is a continuous and uniform operation; but that the method and rate of flow from metal to steam, within the cylinder, is irregular and its precise law unknown.

The work of the Committee results in the recommendation that the thermal economical value of steam-engines should be stated in thermal units per indicated horse-power. It takes the so-called Rankine standard cycle—a thermodynamic cycle with isothermals as upper and lower limiting boundaries and with complete adiabatic expansion and without clearance of compression—as the standard of comparison, the unit of thermodynamic efficiency with which to

compare the efficiency of the real engine, and describes the method of testing and recording results of test and the forms of computation required in affecting this comparison of the ideal with the real case.

The ideal, Rankine, cycle was first proposed by that writer in 1854 in a paper published in Transactions Royal Society of Edinburgh, as of date of January 19, 1854. The paper was reproduced in the 'Miscellaneous Papers of Rankine,' page 400, section 46. Clausius described the same cycle in Poggenдорff's *Annalen*, 1856, and later in his 'Mechanical Theory of Heat,' quite independently, however, of Rankine, of whose work he was at the time unaware.\*

The following are the summarized recommendations of this committee, and it is recommended by them that authors presenting papers to the British Institution of Civil Engineers be invited to conform to these suggestions:

(1) That 'thermal efficiency' as applied to any heat-engine should mean the ratio between the heat utilized as work on the piston by that engine and the heat supplied to it.

(2) That the heat utilized be obtained by measuring the indicator diagrams in the usual way.

(3) That in the case of a steam-engine the heat supplied be calculated as the total heat of the steam entering the engine less the water-heat of the same weight of water at the temperature of the engine exhaust, both quantities being reckoned from 32° F.

(4) That the temperature and pressure limits, both for saturated and heated steam, be as follows:

Upper limit: the temperature and pressure close to, but on the boiler side of the engine stop-valve, except for the purpose of calculating the standard of comparison in

\* Hirst's Translation of Clausius, 1867, page 161. This note, however, does not appear in the German edition of 1876.



cases when the stop-valve is purposely used for reducing the pressure. In such cases the temperature of the steam at the reduced pressure shall be substituted. In the case of saturated steam the temperature corresponding to the pressure can be taken.

Lower limit: the temperature in the exhaust-pipe close to, but outside, the engine. The temperature corresponding to the pressure of the exhaust steam can be taken.

(5) That a standard steam-engine of comparison be adopted, and that it be the ideal steam-engine working on the Rankine cycle between the same temperature and pressure limits as the actual engine to be compared.

(6) That the ratio between the thermal efficiency of an actual engine and the thermal efficiency of the corresponding standard steam-engine of comparison be called the efficiency ratio.

(7) That it is desirable to state the thermal economy of a steam-engine in terms of the thermal units required per minute per Indicated HP., and that, when possible, the thermal units required per minute per Brake HP. be also stated.

(8) That, for scientific purposes, there be also stated the thermal units required per minute per HP. by the standard engine of comparison, which can readily be obtained from a diagram similar to that given, and from which the efficiency ratio can be deduced.

R. H. THURSTON.

*THE KINETIC THEORY OF GASES AND SOME OF ITS CONSEQUENCES.\**

THOUGH Science—Science with a capital S—is often contrasted with Art—Art with a capital A; though the former is held to be dry and unattractive, while the latter stirs the imagination and arouses ‘thoughts that breathe and words that burn;’ yet the

\* Reprinted from the *Contemporary Review* for November, 1898.

follower of science now and then is rewarded for his toil by an ordered sequence which appeals to the imaginative side of his nature, no less than the rhythmic harmony of poetry, or the measured cadences of music. Indeed, it is not impossible for the poet to express better than, and as truly as in the pages of the *Philosophical Transactions*, the highest generalizations of science. In this Tennyson stands unrivalled. Take, for example, the stanzas:

“There rolls the deep where grew the tree,  
O earth, what changes hast thou seen!  
There where the long street roars, hath been  
The stillness of the central sea.

“The hills are shadows, and they flow  
From form to form, and nothing stands;  
They melt like mist, the solid lands,  
Like clouds they shape themselves and go.”

It contains an epitome of the whole of geology. The science is mere elaboration of the ideas contained in Tennyson’s beautiful verses.

The difficulty in gaining the appreciation of the ‘general public’ is in presenting the ideas in intelligible language. That the scientific and the romantic are sometimes closely intermingled is indisputable; but the romance is one which appeals to few. In the following pages an attempt will be made to show how the thoughts of many men, each striving to ‘increase natural knowledge,’ as the formula of admission to the Royal Society runs, have led to a discovery of some interest—that of a hitherto unsuspected constituent of atmospheric air.

The Roman poet Lucretius, a friend and contemporary of Cicero, was the author of a poem entitled ‘*De Rerum Naturâ*’ (‘On the Nature of Things’). In this poem, which treats of almost all things in heaven and earth, he argues that the atoms, the existence of which is obvious because one sees them in a cone of light passing through a dark room, fall rapidly together in their dancing course throughout the spheres,

and by their collision engender all known things. Their paths are, however, not directed, but fortuitous; and, therefore, the world is the product of chance.

Passing over many centuries, we find Boyle, in the reign of Charles II., suggesting that the difference between different kinds of matter is to be explained by the nature and the motion of the particles or atoms of which they are composed. The region of speculation was narrowed when Daniel Bernoulli, in 1738, attempted to account for the law, due to Boyle, that the volume of gases varies inversely with the pressure to which they are exposed; and similar attempts were made by Herapath in 1821, and by Jonle in 1851. Their ideas were systematized by Clausius in 1857 under the name of the 'Kinetic Theory of Gases.'

Briefly stated, the theory is this: Granted that in gases the particles—or, as they are now termed, the molecules—of which they consist are widely separated from each other, and that the pressure which the gas exerts on the sides of any vessel in which it may be confined—a pressure which may be realized by pumping away the air outside the vessel, when, if the vessel is constructed of yielding material, such as bladder, it will distend, and ultimately burst—is caused solely by the bombardment of the molecules of gas on the walls. It is at the first blush not very easy to conceive of a steady pressure being due to an enormous number of impacts irregularly delivered. But there are many analogies which help to form the conception. For instance, a musical note, which may strike us as of the utmost smoothness and uniformity, is in reality the result of a succession of blows on the tympanum of the ear, each following the preceding one too rapidly for our ears to distinguish the break in continuity. In a similar manner the pressure of a gas is accounted for. And the temperature, a rise in which also increases the pressure of

a gas on the walls of a vessel containing it<sup>1</sup> is attributed to the increased velocity of the molecules of the gas. Now, for simplicity's sake, considering a blow given by only one molecule, the force of the blow—to use a rough expression which will serve the purpose—will depend not merely on the rate at which that molecule is moving, but also on the weight of that molecule. So that a light molecule with a high rate of motion may deliver as forcible a blow as a heavy molecule with a slower rate of motion. By Clausius's hypothesis the temperatures of two gases are believed to be equal when the products of their masses into the square of their rates of motion are equal. This is not quite the same thing as saying 'when the force of the blows they give is equal,' but it may be taken as connected with it.

Supposing, then, that two gases are at the same temperature—that when placed in contact neither gives up heat to the other—then the product above mentioned must be equal for both. For it is obvious that the specifically lighter gas must have the higher velocity; that is, the molecules must be endowed with a higher rate of motion.

What is that rate of motion? Clausius was able to answer that question: A molecule of hydrogen, the lightest gas known, if it moved in a straight line, unimpeded in its motion by collision with any other molecules or with any solid body, would pass through no less than a mile and a quarter in a second. And a molecule of oxygen equally free to move would travel through space with a velocity of rather less than one-third of a mile per second. The relative rates of motion are, therefore, in inverse proportion to the square roots of the densities of the gases. Thus, as oxygen is sixteen times as heavy as hydrogen, a molecule of hydrogen would move through space in a straight line, were it free to do so, at a rate four times as great as that at which a molecule of oxygen moves.

\* These rates of motion are calculated for the temperature of melting ice. But as the effect of rise of temperature is to quicken the rate of motion of molecules of gases, so fall of temperature will cause a decreased velocity. The question arises: Is there any possibility of so lowering temperature that the motion of such moving molecules will cease? Judging by the rate at which the pressure of a gas decreases with fall of temperature, there is: That temperature has been called the 'absolute zero of temperature;' it lies  $273^{\circ}$  below the melting point of ice on the Centigrade scale, or at  $-460^{\circ}$  on the Fahrenheit scale, the one commonly in use in this country. This temperature has not been reached; it is unlikely that it will ever be reached; but an approach has recently been made to it by liquefying hydrogen gas and allowing it to boil at the atmospheric pressure. The temperature reached in this manner is about  $-243^{\circ}$  Cent.; and Professor Dewar, who has recently succeeded in liquefying hydrogen in quantity, will no doubt be able to produce a still lower temperature, by causing the liquid hydrogen to boil in a vessel connected with an air pump, so that the pressure is reduced. For just as raising the pressure raises the boiling point of a liquid, as exemplified in the boiler of a steam engine, so lowering the pressure lowers the boiling point.

It is now many years since Dr. Johnstone Stoney applied the Kinetic Theory of Gases, in a series of papers read before the Royal Dublin Societies, to the question of the existence of atmospheres on planets and satellites. If a molecule happens to be moving on the surface of a planet at a rate which would carry it away from the planet more rapidly than the planet can draw it back, that molecule will escape into space. It is not theoretically impossible, although practically unrealizable, to construct a gun which would fire a bullet

vertically into the air at such a rate that the bullet might never return to the earth. What, then, would occur to it? Well, it would wander on through space as a little planet, performing an ellipse round the sun, as indeed many aërolites, or 'shooting stars,' are known to do. It might, indeed, chance to come within the range of attraction of some planet—*e.g.*, Jupiter—massive enough to hold it; or it might actually fall on the surface of a planet; in the former case it would act like a little satellite and revolve round that planet, as the numerous stones of which Saturn's rings are composed revolve round Saturn; in the latter case it would simply become part of that planet, as the falling stars which reach the earth form, after their fall, a portion of the earth.

The molecule of gas, which we have been considering, differs in no particular from a bullet, in its wanderings or in its fate. If it chance to come within the sphere of attraction of a planet of sufficient mass to retain it, it will, according to Dr. Stoney, form part of that planet's atmosphere. If not, it will wander on until it may, by chance, come near enough to the sun to fall a victim to its enormous attractive force, and it will then become part of the sun's atmosphere.

Dr. Stoney has summed up the results of various inquiries of this kind in a memoir, entitled 'Of Atmospheres upon Planets and Satellites.'<sup>\*</sup>

One important point has been omitted in the sketch given of the Kinetic Theory. It is this: When it was said that a molecule of oxygen moves at the rate of about one-third of a mile per second it was not implied that all molecules are moving at that rate. Some, urged on by collisions from behind, acquire a much more rapid rate; others, hindered in their motion by collisions with other molecules moving more

\* 'Royal Dublin Society,' Vol. VI., Nov., 1897, pp. 305-328.



slowly than themselves, or in opposite directions, have their rate of motion decreased. A gas must be conceived as composed of an almost infinite number of such molecules, jostling each other in every conceivable way. The rate of one-third of a mile per second, deduced by Clausius as the average rate of motion of a molecule of oxygen, must be understood to mean that, if all the rates of motion were to be balanced out, so that the swiftly-moving molecules gave up some of their motion to the slowly-moving molecules, and *vice versa*, the molecules would all be moving at the above-mentioned rate. But it must be distinctly borne in mind that this imaginary state of things never occurs. There are always many molecules moving faster, many slower, than the average.

I find, in my own case, that it helps greatly to a clear understanding of such a conception as that of which a short account has been given, if a mental picture can be called up which will illustrate the conception, although even imperfectly. Some such picture may be formed by thinking of the motions of the players in a game of football. At a critical point in the game the players are running, some this way, some that; one has picked up the ball and is running with it, followed by two or three others; while players from the opposite side are slanting towards him, intent upon a collision. The backs are at rest, perhaps; but on the approach of the ball to the goal they quicken into activity, and the throng of human molecules is turned and pursues an opposite course. The failure of this analogy to represent what is believed to occur in a gas is that the players' motion is directed and has a purpose; that they do not move in straight lines, but in any curves which may suit their purpose; and that they do not, as two billiard balls do, communicate their rates of motion one to the other by collision. But, making such reservations, some

idea may be gained of the encounters of molecules by encounters in a football field.

In considering averages it is clear that there must be a practical limit on both sides of the mean. If a man throws dice he may turn up sixes thrice in succession, or some greater number of times, by chance; but it is clear he will not go on throwing sixes forever, though there is no absolute reason why he should not. Similarly, in thinking of the rates of motion of molecules there will be a practical limit of rate at which any one molecule will move. It is unlikely that any one molecule will cease to move for any appreciable time; and it is unlikely, too, that any one molecule will develop any exceptionally rapid velocity, say twenty times the mean. Still, such events may conceivably occur; they will, however, be very infrequent.

Those gases which are light, and whose molecules have a high intrinsic average rate of motion, will, in the nature of things, contain some molecules which happen to be moving at a high speed, and necessarily will contain more such than a gas of higher density, the average rate of motion of whose molecules is slower. It may happen that molecules of each kind, of gas with low as well as of gas of high density, may possess such exceptionally high velocity at the confines of our atmosphere, where there are comparatively few gaseous molecules altogether; and it may also happen that these molecules are moving in a direction more or less nearly perpendicular to the surface of the planet, and it may also happen that such molecules suffer no collisions in their vertical path; if these events all happen the molecules will escape. But as, on the doctrine of chances, there are more molecules of light gas endowed with such exceptionally high velocity than there are of heavy gas, more molecules of the former will escape away from the neighborhood of the planet, and enter free space as independent entities, than of the latter.

Such a process, prolonged over ages, will ultimately remove from the atmosphere of a planet all gases possessing less than a certain minimum density.

The next question to which Dr. Stoney addresses himself is: What rate of motion must a molecule have in order that it may escape from the attraction of the earth? The least velocity which will enable such a molecule to escape is about seven miles per second. And it is assumed, from observations taken at high altitudes, that the temperature of the upper regions of the atmosphere is about  $-66^{\circ}$  Cent., or about  $-87^{\circ}$  Fahr.

This velocity of seven miles a second is, however, considerably greater than the average velocity of a molecule of hydrogen, which, at  $32^{\circ}$  Fahr., it will be remembered, is only about a mile and a quarter. But it is not greater than the velocity of some of the molecules; and these will, therefore, escape. In fact, Dr. Stoney concludes that in every gas a considerable proportion of the molecules have a velocity at least ten times as great as the mean.

Now, on this earth the important constituents of the atmosphere are nitrogen, oxygen, argon, carbon dioxide, water-vapor and ammonia; and their densities are as follows, that of hydrogen being taken as unity:

Nitrogen.....	14
Oxygen.....	16
Argon.....	20
Carbon dioxide.....	22
Water-gas.....	9
Ammonia.....	8.5

We are here chiefly concerned with the gases of the earth's atmosphere, but it may be of interest to cast a glance at other conclusions which follow from Dr. Stoney's speculations.

The moon, the mass of which is much less than that of the earth, would retain a gas of density 40, or thereabouts; but all less dense gases would escape rapidly. From

the planet Mercury water-vapor would at once escape, and it is probable that both nitrogen and oxygen would escape more slowly. Argon and carbon dioxide might, however, be permanent constituents of the atmosphere of Mercury. Venus, on the other hand, retains water-vapor; but lighter gases would escape. It must be remembered that if the water were to escape from a planet in the state of vapor its place would be at once supplied by evaporation of planetary seas, if there were any, and that, in the long run, all the water would, in the state of gas or water, leave the planet.

Indeed, Dr. Stoney thinks it not unlikely that we are slowly losing our stock of water. This, however, need excite no alarm, and our water will probably outlast our coal many millions of years. For so few of the molecules of water comply with the required standard of velocity that the rate of loss is almost infinitesimally small.

Similarly, Dr. Stoney conjectures that water cannot remain on Mars; that all known gases would be imprisoned by Jupiter, and that Saturn, Uranus and Neptune may probably be able to retain all gases heavier than hydrogen. As for the sun, its mass is so enormous relatively to that of the planets that, even at the exceedingly high temperature which its atmosphere possesses, it is impossible for any known gas to remove itself from the neighborhood of the luminary.

We must now take leave of Dr. Stoney's fascinating hypotheses for a time, and consider the recent discoveries of gaseous constituents of our atmosphere.

After the discovery of argon as a constituent of air, in 1894, one of the discoverers, acting on advice given him by Professor Miers, was so fortunate as to isolate helium, a gas contained in certain rare minerals, the best known of which bears the name of clèveite. Helium had previously been detected in the chromosphere, the colored at-

mosphere of the sun, by M. Janssen, the well-known French astronomer; and its name was suggested by Messrs. Frankland and Lockyer, in 1868, to characterize the brilliant yellow line by which its presence in the sun is revealed. Neither of these elements has been combined with others, although it is possible that each exists in combination with one or more of the elements contained in the minerals from which helium can be obtained by heating, for it has been found that small quantities of argon, along with considerable quantities of helium, are evolved from such minerals. Again, both of these elements possess one curious property, which they share with gaseous mercury alone, so far as is known, among all elements. That is technically called the ratio between their specific heats at constant pressure and at constant volume. It would be difficult here to set forth the reasoning by which it is deduced that, inasmuch as the ratio for these gases is  $1\frac{2}{3}$  to 1 between specific heat at constant pressure and at constant volume, the molecules of these elements, unlike those of oxygen and hydrogen and the other commoner gases, but like those of mercury gas, consist not of agglomerations of two or more atoms, but of single atoms. These characteristics at once establish a connection between the two elements helium and argon, and differentiate them in kind from all other gaseous elements.

Now, taking the density of hydrogen as unity, that of helium is very nearly 2 and that of argon 20. And one of the conclusions which follows from the Kinetic Theory of Gases is that equal volumes of gases contain equal numbers of molecules. Thus the fact that helium is twice as heavy as hydrogen carries with it the conclusion that a molecule of helium is twice as heavy as a molecule of hydrogen, whatever the absolute weight of the latter may be.

Now, it can be demonstrated that there

is a strong probability in favor of the assumption that a molecule of hydrogen consists of two atoms, inseparable from each other unless by combination with some other element. And if a molecule of helium consisting of one atom is twice as heavy as a molecule of hydrogen consisting of two, then it follows that an atom of helium is four times as heavy as an atom of hydrogen; in other words, the atomic weight of helium is 4, that of hydrogen being taken as 1. Similar reasoning proves the atomic weight of argon to be 40, from the known fact that it is twenty times as heavy as hydrogen. Moreover, it is noteworthy that the difference between these numbers 40 and 4 is 36.

Mr. John Newlands, whose recent death is deplored by the scientific world, as long ago as 1863 brought forward what he termed a 'law of octaves.' It consisted in arranging the numbers which represent the atomic weights of the elements in seven rows, beginning again with the eighth element, so that its atomic weight occupies a position in the table below that of the first, the ninth below the second, the fifteenth again below the first, and so on. The reproduction of three of such rows will make the meaning clear.

Li	7	Be	9.2	B	11	C	12	N	14	O	16	F	19
Na	23	Mg	24.3	Al	27	Si	28	P	31	S	32	Cl	35.5
K	39	Ca	40	Sc	44	Ti	46	V	52	Cr	52.5	Mn	55
Etc. Etc.													

The elements appear in this table in groups, of which the individual members closely resemble each other, often in appearance, and always in the nature of the compounds they form with other elements. Thus, to take the first column, the three elements lithium, sodium and potassium, together with others not here produced, but which occur later on in the table, rubidium and cesium, are all white waxy metallic solids, easily cut with a knife, tarnishing rapidly in contact with ordinary moist air, and forming compounds which themselves



present the greatest resemblance to one another. Now, in Mr. Newlands' view, the fact that the eighth element resembles the first suggested an analogy with the musical scale, where the tones can be similarly classified, each eighth note of the major scale reproducing, as it were, the fundamental note. In the ordinary notation the name C refers to many notes, separated from each other by octaves. The analogy may be regarded as fanciful, and in the light of more modern work the word 'octave' is here inapplicable; and this perhaps overstrained analogy did much to discredit Mr. Newlands' views in the eyes of the leading chemists of the day. It was not until 1868, when the late Professor Lothar Meyer and Professor Mendeléeff independently arrived at a similar arrangement, that the attention of chemists was recalled to the subject and the justice of Mr. Newlands' ideas was acknowledged. The somewhat tardy award of a medal by the Royal Society placed in its true position the work of Mr. Newlands, and was regarded as an act of justice by his friends. It is deeply to be regretted that his recent death has removed from our midst a man so kindly and so alive to every advance in science.

The elements helium and argon, if they be really elements and not compounds (and there is no reason to doubt their elementary nature), should find places in this table, now known as the 'Periodic Arrangement of the Elements.' And confining our attention to only a few of the vertical columns, their position should be for helium before lithium, and for argon before potassium, thus :

Hydrogen	1	Helium	4	Lithium	7
Fluorine	19	?		Sodium	23
Chlorine	35.5	Argon	40	Potassium	39
Manganese	55	{	Iron 56	Copper	63.5
		{	Cobalt 58		
		{	Nickel 59		
Bromine	80	?		Rubidium	85

Now, we find the difference between the atomic weights of hydrogen and chlorine to be 34.5; and between lithium and potassium to be 32; also between argon and helium to be 36. These numbers are roughly of the same order of magnitude. It is, therefore, not unreasonable to suspect the existence of an undiscovered element with atomic weight between 19 and 23, as well as of others occupying the other unfilled positions in the argon group.

It is no easy matter to hunt the earth through for an unknown element. The question is, where to look. And some clue is necessary to guide the inquiry. At first it was thought that minerals similar to those from which helium had been obtained might possibly yield the new element; and experiments were made, for months at a time, to test the gases obtainable from almost every known mineral, but in vain, so far as a new element was concerned. They resulted in the discovery of many new sources of helium; but the spectrum of the gas in each case exhibited no unknown lines. A new method of attack was then organized. It might be that the so-called helium was really a mixture of elements, and not a pure element. Now, an effective method of separating from each other two gases of different molecular weights, and hence of different densities, is the process of diffusion. From observations of the late Professor Graham, of University College, London, subsequently Master of the Mint, it appears that lighter gases, with rapidly moving molecules, will pass through a porous diaphragm, such as the material of a clay pipe, more rapidly than a heavier gas, with its more slowly moving molecules. An attempt was, therefore, made to ascertain whether any heavier gas could be thus separated from the helium obtained from minerals; the experiments involved an enormous amount of labor, but, in the end, no gas other than a trace of argon could be

detected. It appeared, therefore, vain to attempt to discover a new gas in minerals; and the justice of Dr. Stoney's hypothesis was next tested. It was, of course, not out of the question that the sought-for gas might exhibit some powers of combination, and that it might have been absorbed, along with the nitrogen of the air, by the magnesium over which the gas had been sent at a red heat in order to absorb and remove the nitrogen. The compound of magnesium with nitrogen is very readily decomposed by water; the products are ammonia and hydroxide of magnesium. A large quantity of this magnesium nitride was accordingly treated with water, and the resulting ammonia absorbed by means of weak sulphuric acid. There was merely a trace of gas which refused to be absorbed, and, on examination, it turned out to be the familiar hydrogen, which was formed by the action of the water on some metallic magnesium which had escaped combination with nitrogen. This experiment was interesting, inasmuch as it proved that magnesium refuses to combine with even the smallest trace of argon. The ammonia resulting from this treatment, it is true, might have conceivably contained a compound of the new gas; but a similar sample had previously been decomposed, so as to obtain from it its nitrogen, and that sample of nitrogen had been found by Lord Rayleigh to possess the same density as a sample of nitrogen of which the source could not be traced to the atmosphere. Lastly, it was conceivable that the hydroxide of magnesium might have contained some compound of the new element. It was, therefore, treated with water, and the soluble portion separated from the insoluble. The soluble portion, on examination, proved to contain nothing but the carbonate of magnesium. The insoluble portion was not further dealt with, but was kept in reserve.

The argon of the atmosphere was next

examined. A large quantity having been prepared, it was purified, and by passing it into a vessel immersed in liquid air, made to boil at an even lower temperature than usual by pumping away the air-gases as they boiled off; the argon, too, was completely changed into liquid. Liquid argon is clear and colorless, whereas liquid air has a faint blue tint, owing to the blue color of the oxygen it contains. The argon was next made to boil, by allowing the temperature of the liquid air to rise a few degrees, and the first portions of argon-gas were collected separately, the remainder going back into the gas-holder in which it had originally been stored. The gas thus obtained was lighter than argon, and more difficult to liquefy; this was shown by the necessity of compressing it into the bulb in which liquefaction took place. The most volatile portions of this liquid were next collected separately, and the gas proved to be still less dense than the former sample. It was not possible to liquefy more than a small fraction of this last specimen of gas, to however low a point the temperature of the boiling air was reduced; and after another repetition of the same process the gas appeared to be as light as the process could make it. Its density was 9.75 times that of hydrogen, and, making allowance for a small quantity of argon which it must necessarily have contained, this number becomes reduced to 9.6.\* The weight of a molecule, compared with the weight of an atom of hydrogen, as previously explained, must therefore be 19.2; and 19.2 lies between the atomic weights of fluorine, 19, and of sodium, 23, falling therefore into the predicted place in the Periodic Table. The specific heat ratio of this new gas, to which

\* This gas has since been found to contain a trace of helium, the presence of which would lower the above density. The actual density will, therefore, be somewhat higher than 9.6, but it will probably not exceed 10. It has not yet been determined.

the name 'neon,' or 'the new one,' has been given, is, as in the cases of helium and argon,  $1\frac{2}{3}$ ; like them, too, it resists combination with other elements, and possesses a brilliant and characteristic spectrum.

This account of the fulfilment of a prediction has, I am afraid, been somewhat elaborate for the general reader; but it is interesting as a case of discovery, where many lines of evidence, founded on the work of many different observers, have led to the foreseen conclusion. It possesses, to my mind at least, some of the qualities of a scientific poem—an orderly arrangement of ideas, drawn from many different sources, each throwing light on the other, and all tending towards a final event. It is true that the subject is not one to which poetical diction can be applied with advantage; the details are too complicated, too unfamiliar, and to be expressed only in language which has not received the impress of poetical tradition; but to enlarge on this would open a wide field of discussion, in which æsthetics, a subject not as yet reduced to accurate formulation, and perhaps hardly susceptible of treatment by scientific methods, would form the chief theme.

In epic poems the 'argument' usually precedes the matter. Here it may be convenient to reverse the order and to sum up the preceding pages by the argument. We have seen, then, that the discovery, by Lord Rayleigh, of a discrepancy in the density of atmospheric nitrogen has resulted in the discovery of a new constituent of air—argon; its discovery has led to that of a constituent of the solar atmosphere, helium; speculations on the ultimate nature and motion of the particles of which it is believed that gases consist has provoked the consideration of the conditions necessary in order that planets and satellites may retain an atmosphere, and of the nature of that atmosphere; the necessary existence of an undiscovered element was foreseen, owing to

the usual regularity in the distribution of the atomic weights of elements not being attained in the case of helium and argon; and the source of neon was, therefore, indicated. This source, atmospheric air, was investigated, and the missing element was discovered. A new fact has been added to science, and one not disconnected from others, but one resulting from the convergence of many speculations, observations and theories, brought to bear on one another.

WILLIAM RAMSAY.

---

ON SOME ANALOGIES BETWEEN THE PHYSIOLOGICAL EFFECTS OF LACK OF OXYGEN, HIGH TEMPERATURE AND CERTAIN POISONS.

ONE of the striking characteristics of vital phenomena, from a chemical standpoint, is the comparatively low temperature at which oxidations take place. Among the more commonly accepted theories which try to account for this fact is that of Hoppe-Seyler. Hoppe-Seyler found that in case of putrefaction reducing substances, such as nascent hydrogen, are formed. These reducing substances, if atmospheric oxygen is present, attack the molecule of oxygen, taking one atom to themselves and setting free one atom. This free atom of oxygen, being in an active state, is able to bring about the oxidations characteristic of living organisms.

According to Hoppe-Seyler's theory similar fermentations take place in all living matter whereby reducing substances are formed. In case of lack of oxygen it is clear that, while fermentation may go on, the oxidation of the reducing substances comes to a standstill. In this case the reducing substances may attack other substances in the animal body, instead of oxygen, and form compounds which may act as poisons.

It is a well-known fact that an increase



of temperature up to a certain limit increases fermentation. Suppose the temperature of a cold-blooded animal be raised to 35 or 40°C. Fermentation will be enormously increased; in fact, it may become so great that all the reducing substances formed are not able to find sufficient oxygen for oxidation. Hence, the same condition may obtain as in lack of oxygen. To show this similarity of death by lack of oxygen and heat, we made, at the suggestion of Dr. Loeb, the following experiments upon the protozoan, *Paramecium Aurelia*. A great number of these little organisms were placed in small glass dishes and either subjected to a temperature of 35–40° or to lack of oxygen. First, a lot of *Paramecia* were placed in distilled water and the length of time necessary to kill them by lack of oxygen was noted. Next, two more lots were placed in a weak solution of alkali (NaOH) or acid (HCl). It was found that, compared with pure water, acids in concentration even as low as 1/876% decreased the time necessary to kill *Paramecia* by lack of oxygen; while alkalies of even 1/800% increased the time by 75–175%.

What has been said concerning lack of oxygen and the effects of acid and alkali may be repeated for high temperature. Acid decreases the time needed to destroy *Paramecia* by high temperature. Sodium hydrate, on the other hand, increases the time as much as from 20 to 80%. The similarity in these two cases, *i. e.*, lack of oxygen and high temperature, is, therefore, very striking.

How can we explain these facts? Why is it that alkali increases the resistance power of *Paramecia* against heat and lack of oxygen?

We stated that in case of lack of oxygen fermentation goes on, but that the oxidation of the reducing substances is diminished and finally stopped, and that these reduc-

ing substances may act destructively upon the organism. Now we may suppose that alkalies act either upon the reducing substances themselves or upon the injurious substances formed by them so as to render them inert.

The same course of reasoning applies in regard to the behavior of alkali in case of high temperature.

To prove this we have still another test. Claude Bernard and Geppert have found that in an animal poisoned by potassium cyanide the blood remains arterial and the tissues have lost the power to take up oxygen. In other words, such an animal really dies because of lack of oxygen. If, then, our theory is correct that alkali is beneficial in lack of oxygen we might also expect alkali to prolong the life of *Paramecia* poisoned by potassium cyanide. In order to prove this we made the following experiments.

One drop of 1% KCN solution was placed in a dish containing 10 drops of water and one drop of culture containing *Paramecia* was added. The length of time taken to destroy all the animals was noted. The same experiment was repeated, but instead of water a weak solution of sodium hydrate (1/200–1/2000%) or of acid was used. In all cases the acid shortened the time; salt solutions (1/200–1/2000%) had no effect; alkali increased the length of time from 50 to 300%.

The same results were obtained in case of poisoning by atropin. When it is remembered that solutions of KCN and atropin are alkaline in reaction, it is evident that the beneficial effect of sodium hydrate is not due to its antagonizing these poisons directly.

This is still better seen in the experiments with Sulphate of Strychnia. As the strychnia solution employed had a decidedly acid reaction, *a priori*, we should expect that here alkali would show its beneficial action

most signally. Yet both acid and alkali decrease the power of resistance of *Paramecia* against this poison. Neither has alkali a favorable action in case of poisoning by veratrin, although this, like KNC and atropin, has an alkaline reaction.

We thus see that our theory also stands this test successfully. As alkalies and not acids have this property, it seems possible that the destructive substances formed by fermentation are acids. Whatever may be the real explanation, the fact remains true that *Paramecia* are able to endure lack of oxygen, high temperature and the action of poisons like KNC and atropin for a longer time in weak alkali solutions than in neutral or acid solutions.

WILLIAM ZOETHOUT.

HULL PHYSIOLOGICAL LABORATORY,  
UNIVERSITY OF CHICAGO.

LEIDY'S GENUS *OURAMÆBA*.

HISTORY.

At a meeting of the Dublin Microscopical Club, February 15, 1866, Mr. William Archer exhibited specimens of *Amœba villosa* (Wallich), calling special attention to the presence of "a large and numerous tuft of very long prolongations issuing from just behind the villous patch. \* \* \* He thought it could readily be seen that these curious fasciculi were not composed of foreign bodies either issuing from or penetrating into the *Amœba*, but were really linear prolongations of the sarcode itself. \* \* \* This observation, *quantum valeat*, seems possibly to point to a still greater differentiation of parts than has yet been observed in this remarkable form."\*

After nearly eight years, October 23, 1873, Mr. Archer again drew the attention of the Dublin Microscopical Club to the same condition in *Amœba*. He still considered the projections from the posterior end to be prolongations of the body sub-

stance, though the behavior (as regards flow of contents, locomotion, etc.) was quite that of an *Amœba villosa*.\*

In May of the year following, Dr. Joseph Leidy, of the University of Pennsylvania, found in the vicinity of Philadelphia a singular amœboid creature carrying tufts of caudal filaments, and gave a brief description of it in the *Proceedings of the Academy of Natural Sciences of Philadelphia*, bestowing upon it the name *Ouramœba*, in allusion to its tail-like filaments, and distinguishing several forms.† An abstract of this paper published in the *Monthly Mic. Journal*, November, 1874, brought from Mr. Archer the citation of his original notice of 1866, both observers reaching the conclusion that they had lighted upon the same creature.‡ An illustrated notice of the form by Dr. Leidy appeared in the *Philadelphia Proceedings of 1875*.§ In 1879 the *Fresh-water Rhizopods of North America* was issued under the auspices of the U. S. Geological Survey. Dr. Leidy's final treatment of *Ouramœba* occurs in that sumptuous volume. The points which bear directly upon the thesis of the present paper may be briefly summarized:

1. The caudal filamentous appendages alone excepted, Leidy remarked no difference between *Ouramœba* and *A. proteus*; while Mr. Archer regarded the form observed by him as identical with *A. villosa*, the filaments excepted.||

2. "The mode of fixation of the caudal filaments is difficult to comprehend. In a detached tuft the root appeared to be continuous with a ball of homogeneous protoplasm."¶

\*Idem, 14:212.

† *Proceed. Acad. Nat. Sci. Phila.*, 1874, p. 78.

‡ In 1874 Mr. Archer doubted the validity of the proposed genus *Ouramœba*, although he thought the filaments retractile. See *Quart. Jour. Mic. Soc.*, 15: 203; but compare Idem, 16: 337.

§ Idem, 1875, p. 126 f.

|| *Fresh-Water Rhiz. N. Amer.*, p. 68.

¶ Idem, p. 69.

\**Quart. Journ. Mic. Soc.*, 6:190.

3. "In the movements of *Ouramæba* the caudal filaments were entirely passive."\*

4. "When first seen I regarded the animal as an *Amæba proteus* dragging after it a bundle of mycelial threads [accidentally attached to it?]. \* \* \* I came to the conclusion that the threads were parts of its structure. \* \* \* The caudal filaments present so much resemblance to the mycelial threads of fungi that I have suspected they may be of this nature, and parasitic in character, due to the germination of spores which had been swallowed as food. \* \* \* There is, however, perhaps an important objection to this view, and that is, the caudal filaments do not grow from a mycelium within the protoplasmic mass of the body of the animal. According to Mr. Archer, *Ouramæba* \* \* \* may be only a varietal form of what I have considered to be *Amæba proteus*, but the solution of the question remains for future investigation."†

The next published allusion to this problematic creature was in 1885.‡ Dr. Gruber, in the description of his species *Amæba binucleata*, speaks of fungus filaments lying within the body, but which, in a chromic-acid preparation, issued in tufts and in some places covered the exterior. Confessing that he cannot explain this singular effect of the acid, he suggests that the coming-out of such fungus threads in the living animal might produce appearances like those figured by Leidy, and that the strange attachments to Leidy's *Ouramæba* are nothing but such fungi.

My own study of it began February 6, 1894. The specimen was taken three days before at Wake Forest, in a small stream but a few yards out of a spring. The current was checked by a luxuriant growth of a pond-weed here and there, so that a large

brown *Oscillaria*, which abounded in the collection, had no trouble to keep its footing and thrive. This first specimen I had under observation from the 6th of February to the 22d of March, though after the first six days it was in the encysted condition represented in Fig. 7. At no other season of the year than February and March and in no other locality have I met with specimens.

#### EXPLANATION OF PLATE.

Fig. 1. Filament of *Ouramæba* branched near peripheral end. *Free-hand*.

Fig. 2. Another mode of branching. *Free-hand*.

Fig. 3. Detached filament, sketched free-hand as it lay free in the water a few minutes after its separation.

Fig. 4. Cluster of detached filaments. *Free-hand*.

Fig. 5. A filament of a detached and somewhat disintegrated mass, showing connection with the spore.

Fig. 6. A cluster of filaments springing from included spore whose wall is plainly distinguishable. *Somewhat diagrammatic*.

Fig. 7. Encysted *Ouramæba*: *a*, filament still attached to the protoplasm, which is contracted from cyst-wall; *b*, shed filament in mass of débris, *c*, attached to cyst. *Cam. luc.* × 95.

Figs. 8-10. The same cluster of filaments in three successive stages of development, the stage in Fig. 9 being one day older than that of Fig. 8, and Fig. 10 two days later than Fig. 9. *a* and *b* are the original branches of the germ-tube; *a'*, *a''*, primary and secondary branches of *a*; *b'* and *b''*, primary and secondary branches of *b*; *c. v.*, contractile vacuole. *After tracings of Mr. Martin F. Woodward's camera lucida drawings.* × 800.

Fig. 11. Portion of a large specimen, showing attachment of three clusters of filaments. *After Mr. Martin F. Woodward.* × 800.

\* Fresh-Water Rhiz. N. Amer., p. 69.

† Idem, p. 69-70.

‡ Gruber, Zeitschrift f. Wissenschaft. Zool., 41:210, 211.



In a note published in *Nature* for May 24, 1894 (Vol. 50, p. 79), I announced the conviction that the filaments are a parasitic fungus growing upon the genus *Amœba*. Early in 1896 Mr. Martin F. Woodward, of

to make the fullest recognition of this courtesy, with sincere acknowledgment of my obligations to him. I am indebted, furthermore, to Mr. Irving Hardesty, of the University of Chicago, and Dr. C. L. Felt, of



the Royal College of Science, London, wrote me that he entertained the same view. Later, with signal generosity, he forwarded to me notes of his own observations with tracings of his original drawings. I wish

Philadelphia, for assistance upon the literature of the form.

#### THESIS.

Leidy's genus *Ouramœba* was erected upon insufficient data and must be abandoned.

The filamentous appendages, which constitute the only peculiarity of the form, are not, as he and Archer supposed, extensious of the body-substance; they are, on the contrary, mycelial hyphæ, commonly unseptate, which spring from a spore lying in the endosarc, and which stand in a semi-parasitic relation to the genus *Amæba*.

The facts which I submit in support of this thesis are both morphological and physiological.

1. *Morphological*.—It may be remarked at once that Dr. Leidy's text description and plate delineations represent, with life-like precision, the general features of the structure, and make it unnecessary to set forth here what has already been done so admirably. I mention only what he omitted to notice or failed to see the exact significance of.

a. The single or tufted filaments arise invariably from a spore. See Figs. 3, 4, 5, 6, 10. In Dr. Leidy's Plate IX., Fig. 11, there is a suggestion of this structure, but the text reference to it shows that he did not recognize the spore.\* In the specimens which I studied it was usually conspicuous, though the structural continuity of spore and filament could not always be made out, even when the filaments were detached. Cf. Figs. 3, 4 and 6. In this case, however, the spore came away with the filaments.

This would seem to be decisive of the fungoid nature of the filaments. Leidy's already quoted objection, viz., that the filaments do not grow from a mycelium within the body of the animal, becomes groundless when it is seen that the filaments are themselves the branched mycelium resulting from the germination of the spore. The fact that the mycelium, instead of ramifying through the protoplasmic mass, issues at once into the water, suggests that this

fungus does not subsist at the expense of the *Amæba*, but upon organic substances dissolved in the water. Some of these are doubtless contributed by the contractile vacuole, which, as I observed, always lies in the neighborhood of the filaments; in at least one case I saw it discharge its contents among them. If this be true, we may accordingly mention two advantages which the fungus secures by its association with the *Amæba*: first, a food-supply in the wastes of the *Amæba*; second, change of location with consequent improvement of 'pasturage.\*' And so I have spoken of the dependence as semi-parasitic.

b. The structure of the filaments is that of unseptate hyphæ, not that of pseudopods. An occasional septum at the origin of a branch makes the pseudopod interpretation impossible. It must be said, however, that the characteristic mode of branching is peculiar among the fungi.

c. After separation from the *Amæba* the filaments maintain in all respects their specific structure and relations. In some cases I saw tufts of filaments, each with its spore, come away from the host, for no apparent reason, as it moved through the water. At other times, by pressure upon the cover-glass, the filaments were forcibly separated. In all cases the filaments were unaffected by the change, and the *Amæba* showed no sign of his loss in either his structure or his movements.

2. We may attend now to certain *physiological* facts bearing upon the thesis of this paper.

a. As noted above, the form on which these fascicled hyphæ were found by Mr. Archer in Ireland was *Amæba villosa*. Mr. Woodward informs me that the same is true of his specimens, found, I presume, in the neighborhood of London. If I have correctly interpreted Dr. Gruber, he found

\* Fresh-Water Rhizopods, p. 68. Cf. Proceed. Acad. Nat. Sci. Phila., 1874, p. 78.

\* Gruber (loc. cit.) suggests the advantage of oxygen supply from ingested algæ.

these structures on his species *A. binucleata* in Germany. But the host form in this country, according to Leidy's observations and my own, is *A. proteus*. As Mr. Woodward suggests, this fact of itself creates a presumption of the fungoid nature of the filaments.

b. The occurrence of the form at a limited season of the year is in keeping with the plant nature of the filaments. While one of the specimens of Mr. Archer appears to be an exception, all the others were found, I infer, in the early part of the year, from January to May. My own were taken in February or March of three successive years. The same locality was searched for them at other seasons in vain, though uninfested *Amæba* were found.

c. The hyphæ take no part in the movements of *Amæba*. If they bend or diverge, such movements are entirely passive, being due to contractions of the protoplasm to which their bases are attached. This is the explanation of what Archer interpreted as the creature's power of bending and quickly again erecting the filament at the point of constriction.\* All observers agree that they are non-retractile. Cf. Fig. 7, a and b.

d. The progressive development of a single tuft is sufficient of itself to establish the main point of the thesis. It is clearly indicated in Figs. 8, 9 and 10, which are three of a series of five drawings representing as many stages of development of the same cluster. The fourth and fifth are not shown. Mr. Woodward tells me that after the first week the cluster of filaments became too complicated in its branching to draw, "although they always retained their original character of springing from a basal U-shaped filament and not branching near the distal extremities." Furthermore, Mr. Woodward observed on the same slide with this large specimen a number of small ones

which "only after a week were found to possess any filaments."

\* \* \* \* \*

An interesting inquiry remains to be made into the life history and relationships of the fungus itself, but upon that inquiry I cannot enter now.

WM. L. POTEAU.

WAKE FOREST COLLEGE, N. C.

NEW NAMES FOR *SPERMOPHILUS BREVICAUDUS*, *CANIS PALLIDUS* AND *SOREX CAUDATUS* MERRIAM.

THREE names given by me to new species of mammals prove to be preoccupied and are here replaced.

*Spermophilus chrysodeirus brevicaudus* Merriam (Proc. Biol. Soc. Wash. VIII., 134, December 28, 1893), from the San Bernardino Mountains in California, is preoccupied by *Spermophilus brevicauda* Brandt (Bull. Acad. St. Petersburg, 1844, II., 369) from the southern Altai. I propose in its stead *Spermophilus (Callospermophilus) bernardinus*.

*Canis pallidus* Merriam (Proc. Biol. Soc., Wash., XI., 24, March 15, 1897), from the plains of Nebraska, is preoccupied by *Canis pallidus* Rüppell (Atlas zu Reise in Nördl. Afrika I., 33, taf. 11, 1826) from Kordofan. I propose in its stead *Canis nebracensis*.

*Sorex saussurei caudatus* Merriam (N. Am. Fauna, No. 10, p. 84, Dec. 31, 1895), from Reyes, Oaxaca, Mexico, is preoccupied by *Sorex caudatus* Hodgson (Horsfield's Catal. Mammals Mus. East India Co., p. 135, 1851), from Sikkim and Darjeling, India. I propose to replace it by *Sorex saussurei mutabilis*.

C. HART MERRIAM.

A NEW NAME FOR *MICROTUS INSULARIS* BAILEY.

In a preliminary paper describing several new Voles (Proc. Biol. Soc. Wash., XII., 86, April 30, 1898) I gave the name *Microtus insularis* to a species from Great Gull Island, N. Y. This name proves to be pre-

\* Quar. Journ. Micr. Soc.: 6, 190.



occupied by *Lemmus insularis* Nilsson (= *Microtus agrestis* L.), described in the *Cefversigt K. Vetensk. Akad. Förhandlingar*, Stockholm, I., 33-35, 1844. I therefore propose the name *nesophilus* in place of *insularis* for the Great Gull Island *Microtus*.

VERNON BAILEY.

CHANGE OF NAME FOR *SCIURUS ALBIPES*  
*QUERCINUS NELSON*.

THE name *Sciurus quercinus* which I used for a Mexican squirrel recently described as *S. albipes quercinus* (*Proc. Biol. Soc. Wash.*, June 3, 1898, XII., pp. 150-151), proves to be preoccupied by Erxleben (*Syst. Reg. Anim.* 1777, p. 432). I therefore propose for the Mexican subspecies the name *hernandezii*.

E. W. NELSON.

NOVEMBER 19, 1898.

PROFESSOR JAMES INGRAHAM PECK.

By the death of James Ingraham Peck, Williams College loses an able and beloved professor; the Marine Biological Laboratory, an executive officer of rare ability; American Biology, an investigator of keen perception; and a host of young biological workers, a willing helper and an inspiring friend.

Dr. Peck was born at Seneca Castle, Oneida county, New York, August 10, 1863, and entered Williams College from Canandaigua Academy when twenty years of age. After the completion of his college course he remained for one year as a graduate student, and took a second year of graduate work at Johns Hopkins University. In 1892 he was appointed assistant in biology at Williams College, and in 1894 he was promoted to the position of assistant professor, which office he held until the time of his death, November 4, 1898. He leaves a wife, a woman universally beloved, and a little boy.

Although Dr. Peck was a thorough teacher and a man of unusual popularity

both with students and officers, it was not through his academic work at Williams-town, but rather through his scientific and executive work at Woods Holl, that he was best known.

In 1888 Dr. Peck prepared one of the first serious contributions to the study of Variation that had been made since the time of Darwin. The summer of 1889 he spent at Woods Höll, where he worked upon the habits of the young of certain food fishes. In 1890 he published his *Cymbuliosis* paper. In 1892 he was again a member of the scientific staff of the Fish Commission Laboratory, where he worked upon the Pteropods and Heteropods collected by the Albatross. The summer of 1893 was spent in preparing his paper on the 'Food of the Menhaden,' and in 1894 he continued his plankton studies and prepared a paper on the 'Sources of Marine Food.' In 1895 he was placed in charge of the Laboratory of the Fish Commission, and in 1896 he accepted the position of Assistant Director of the Marine Biological Laboratory.

For the three years that Dr. Peck was in charge of the general affairs of the Marine Biological Laboratory he worked with untiring energy, and inspired all who visited the Laboratory with a spirit of devotion to science and of loyalty to the institution. During the past summer he worked with unabated energy, denied himself the many opportunities for rest and recuperation that his students and friends besought him to take, and returned to Williamstown entirely unfitted to withstand the strain of severe illness. He literally sacrificed himself for science.

H. C. BUMPUS.

BROWN UNIVERSITY, PROVIDENCE, R. I.

NOTES ON INORGANIC CHEMISTRY.

THE leading article in the last number of the *Chemical News*, is a long criticism of the recent, supposed discovery of a new gas,

etherion, by Charles F. Brush, from the pen of the editor, Sir William Crookes. From his long continued familiarity with work at low pressures, especially in connection with work on radiant energy, and on the so-called meta-elements, it is hardly an exaggeration to say that there is no more competent critic of Brush's work than Professor Crookes. He has repeated some of Brush's experiments and is inclined to attribute the peculiar phenomena obtained to the presence of a trace of aqueous vapor. This seems the more probable, in view of the fact that Brush found that the etherion seemed to be absorbed by phosphorus pentoxid and by soda-lime. Having only seen the abstract of Professor Brush's paper, Professor Crookes does not assume to speak authoritatively in the matter, but only of the probabilities. In their modest, unassuming tone, the papers of both these distinguished scientists might well serve as models.

IN an article on the reactions of acetylene in the *Zeitschrift für anorganische Chemie*, Hugo Erdmann and Paul Köthner call attention to the possibility of utilizing acetylene for the production of aldehyde. The thought of the commercial synthetic production of similar substances is not new. Several years ago Krüger and Pückert proposed the manufacture of alcohol by precipitating acetylene with corrosive sublimate, treatment with hydrochloric acid and reduction of the aldehyde formed; indeed, nearly half a century ago the manufacture of 'mineral spirits' was exploited. Apparently these processes would all be too expensive for the production of alcohol, while the continuous process of Erdmann and Köthner might be a commercial possibility for making the more valuable aldehyde. This process consists in leading acetylene through a boiling mixture of 44% sulfuric acid in the presence of mercuric oxid. The aldehyde distills off and the unused

acetylene is recovered. The presence of phosphoric acid seems to give a purer product. In a quantitative experiment from 125 grams calcium carbid of 95%, there were obtained 80 cc. of 5% aldehyde. It is not at all improbable that the cheap production of acetylene from calcium carbid may render possible, in the near future, many syntheses of organic products on a commercial scale.

THE verification of inorganic data of past years has received a valuable contribution from A. Ladenburg, in the *Berichte*, in the redetermination of the density of ozone. Soret's classic researches of thirty years ago on ozone were with a mixture containing only 5 per cent. ozone and hence not beyond criticism. In Ladenburg's method an 8 to 9 per cent. mixture of ozone and oxygen was directly obtained by usual methods and this mixture condensed to a liquid by means of liquid air. On boiling the mixture much of the oxygen could be driven off, and by repeating the process several times a liquid mixture was obtained containing 86 per cent. ozone. For determination of density Bunsen's 'Ausströmungszeit' method was used. The density found for pure ozone relative to that of oxygen was 1.456, which is very close to the theoretical value 1.5, and the generally received composition of ozone,  $O_3$ , is confirmed. In this investigation it was incidentally found that liquid ozone is very dark blue and in layers two or three centimeters thick completely opaque; that it is almost insoluble in water, but 0.00002 part by weight and 0.01 part by volume being dissolved in one of water. In determining the boiling point a mixture of ozone and oxygen boiled at  $-186^\circ$  until apparently only ozone was left. The thermometer then rose to  $-125^\circ$  when the liquid ozone appeared to begin boiling. At this moment a very violent explosion occurred, the whole apparatus being shattered. It would appear from this that the boiling

point of ozone cannot be below  $-125^{\circ}$ . According to Troost it is  $-119^{\circ}$ , while earlier, Olszewsky had placed it at  $-106^{\circ}$ .

J. L. H.

CURRENT NOTES ON METEOROLOGY.

AUGUST HOT WAVE IN CALIFORNIA.

THE August number of the California Section of the Climate and Crop Service contains an account of the hot wave of that month, by George H. Wilson. This hot wave lasted one week, and was the most severe on record, throughout the Sacramento and portions of the San Joaquin Valleys. Maxima up to  $120^{\circ}$  were noted, and the temperatures were about  $20^{\circ}$  above the normal in the great valleys on August 11th. In the Sacramento Valley it is stated that birds flew into the houses, seeking shelter from the withering heat, and in a few cases they are reported to have fallen dead from the trees. During the hot wave there was a marked absence of northerly winds in the interior valleys, and as the ground was very dry, owing to a drought, the surface was effectively heated.

MONTHLY WEATHER REVIEW.

THE August number of the *Monthly Weather Review* is one of unusual interest. Among the papers it contains are the following: 'The Effect of Approaching Storms upon Song Birds,' by C. E. Linney; 'Progress in the Exploration of the Air with Kites at the Blue Hill Observatory,' by A. Lawrence Rotch; 'Destruction by Lightning in New York State during the month of August, 1898,' by R. G. Allen; 'The Measurement of the Wind,' 'Sensible Temperatures or the Curve of Comfort,' and 'Waterspouts on the Lakes,' by Professor Cleveland Abbe.

NOTES.

THE Southern Pacific Railroad Company has recently supplied ordinary meteorological instruments to 181 of its stations be-

tween Ashland, Ore.; Ogden, Utah, and El Paso, Texas. The state of the weather, direction of wind, temperature and rainfall are included in the daily record, and at nine important points pressure readings are made. Daily telegraphic reports are forwarded from each point to San Francisco. Weekly crop reports are also sent from 52 important producing centers. The Company forwards over its own wires, without charge to the government, warnings of frosts and hot northers. The meteorological observations thus collected are placed at the disposal of the Weather Bureau.

In the September number of the *Monthly Review* of the Iowa Weather and Crop Service it is noted that of 266 head of live stock killed in Iowa by lightning during the past summer 118 were found in close contact with wire fences.

R. DE C. WARD.

HARVARD UNIVERSITY.

BOTANICAL NOTES.

SOME MORE ATROCIOUS BOTANY.

It is quite bad enough that we have textbooks on elementary botany that are so full of error that teachers have to be warned not to use them, but now we find a new source of confusion and erroneous infection in an unexpected quarter. Our attention has just been called to a recent book, 'Applied Physiology,' by Dr. Overton, published by the American Book Company, in which the author manages to bring in more than the usual number of misrepresentations and misleading statements regarding plants, commonly found in such books. The following examples will give an idea of the botanical abulium which the Doctor supplies to his pupils:

"The greater part of all young plants is starch" (p. 26). "Each grain [of starch] is made up of layers of pure starch separated by an exceedingly thin layer of a substance like cotton, called cellulose" (p. 26). "As



a plant grows, the starch is changed into wood" (p. 26). "When yeast germs are added to bread dough they grow rapidly and produce alcohol and carbonic acid gas out of sugar, which is always found in flour" (p. 43). "Mold is a common plant which lives upon albumin. It can grow upon the coarsest kinds, as upon wood or leather, as well as upon the best, as meat or cheese. It consists of tiny rods scarcely  $\frac{1}{1000}$  of an inch in length, joined end to end" (p. 383). "Bacteria produce decay." \* \* \* \* "All decaying matter is intensely poisonous from the presence of these toxins" (p. 384). "Mold, a microscopic plant whose filaments in their growth burrow through substances. At intervals they send up seed-stalks which form a velvet-like covering" (Glossary, p. 415). "Nucleus, a darker mass in the midst of a cell" (Glossary, p. 416). "Spore, the germ cell of a flowerless plant" (Glossary, p. 421). See "Germs, a common name for bacteria of disease" (p. 411). "Starch, a food substance composed of carbon hydrogen and oxygen in the same proportions as in sugar" (Glossary, p. 421). "Sugar, a sweet substance composed of carbon, hydrogen and oxygen in the same proportions as in starch" (Glossary, p. 421).

There can be no valid excuse for the publication of such stuff as the foregoing. No publishing house should allow a manuscript to go to press until it has satisfied itself that the book is reasonably free from errors, not only in the principal subject treated, but in those subjects which receive secondary consideration.

#### WESTERN WEEDS.

A RECENT bulletin from the Idaho Experiment Station is devoted to a discussion of 'Twelve of Idaho's Worst Weeds.' It includes: 1, Wild Oats (*Avena fatua*); 2, Prickly Lettuce (*Lactuca scariola*); 3, Russian Thistle (*Salsola kali tragus*); 4,

Tumbling Mustard (*Sisymbrium altissimum*); 5, Cockle (*Saponaria vaccaria*); 6, Canada Thistle (*Carduus arvensis*); 7, Alfalfa Dodder (*Cuscuta* sp.); 8, False Flax (*Camelina sativa*); 9, Sunflower (*Helianthus annuus*); 10, Squirrel-tail Grass (*Hordeum jubatum*); 11, Common Tumble Weed (*Amaranthus albus*), and 12, Horehound (*Marrubium vulgare*). To an Eastern farmer this list will appear quite strange, as with but two or three exceptions the plants, which are among the worst weeds in Idaho, are of little importance as weeds in the East.

A similar list made by the writer four years ago for eastern Nebraska is, perhaps, still more striking. These are the weeds of the fields and pastures approximately in the order of their harmfulness, beginning with the worst: 1. Russian Thistle (*Salsola kali tragus*); 2. Sand-bur (*Cenchrus tribuloides*); 3. Milk-weed (*Asclepias syriaca*); 4. Buffalo-bur (*Solanum rostratum*); 5. Sunflower (*Helianthus annuus*); 6. Horseweed (*Erigeron canadensis*); 7. Big Ragweed (*Ambrosia trifida*); 8. Bitterweed (*Ambrosia artemisiifolia*); 9. Squirrel-tail Grass (*Hordeum jubatum*); 10. Cockle-bur (*Xanthium canadense*); 11. Porcupine Grass (*Stipa spartea*); 12. Purslane (*Portulaca oleracea*). In this list, again, the Eastern farmer will note the absence of most of the weeds which trouble his fields. On the other hand, he has had no experience with 1, 2, 4, 5, 9 and 11, as weeds.

#### ECONOMIC GRASSES OF THE UNITED STATES.

PROFESSOR SCRIBNER, of the Division of Agrostology, of the United States Department of Agriculture, has just issued a valuable bulletin (No. 14) describing the grasses which are used for forage, ornamental and other purposes. No less than 252 species are included, many of which are introduced from other countries, while many, perhaps most, are natives of this country. Good figures are used to aid in

the identification of many of the species. At the end of the bulletin the most important grasses are brought together under six heads. Here there are given of Hay Grasses, 38 species; Pasture Grasses, 36 species; Lawn Grasses, 15 species; Grasses for Wet Lands, 25 species; Grasses for Embankments, 20 species; Grasses for Holding Shifting Sands, 20 species. The last list is of such general importance that it is reproduced here, with the original locality of each species added:

*Agrostis coarctata* (sea coast, Newfoundland to New Jersey).

*Ammophila arenaria* (sandy coasts of the Atlantic and shores of the Great Lakes).

*Andropogon hallii* (sand hills of Nebraska to Texas).

*Calamovilfa longifolia* (sandy shores of the Great Lakes, and sandy soil of the Western prairies and plains).

*Cynodon dactylon* (tropical and warm temperate regions of the globe).

*Elymus arenarius* (seacoasts of Europe and eastern and western North America).

*Elymus mollis* (Atlantic and Pacific coasts of North America, and shores of the Great Lakes).

*Eragrostis obtusiflora* (sandy soils in Arizona).

*Imperata arundinacea* (tropical and warm temperate regions of both hemispheres).

*Muhlenbergia pungens* (sand hills of Nebraska to New Mexico and Arizona).

*Panicum amarum* (sandy seacoasts, from Connecticut to Florida and the Gulf).

*Panicum repens* (shores of the Gulf of Mexico and in the maritime districts of southern Asia, northern Africa, southern Europe and Anstralia).

*Redfieldia flexuosa* (sandy districts of Nebraska, Colorado and Kansas).

*Spartina patens* (salt marshes from Maine to Florida and along the Gulf coast).

*Spinifex hirsutus* (sandy coasts of Australia, New Zealand and Tasmania).

*Stenotaphrum dimidiatum* (tropical and warmer regions of both hemispheres).

*Thuarea sarmentosa* (sandy coasts of Ceylon and northern Australia).

*Uniola paniculata* (drifting sands of the seashore, from Virginia to Florida and Texas).

*Poa macrantha* (sand dunes of northwestern United States).

*Zoysia pungens* (sandy shores of eastern Asia, Australia and New Zealand).

CHARLES E. BESSEY.

THE UNIVERSITY OF NEBRASKA.

#### CURRENT NOTES ON ANTHROPOLOGY.

##### INFLUENCE OF SEX ON CRIME.

IN his interesting work 'Juvenile Offenders' (New York, 1897) Mr. W. Douglas Morrison investigates the question why the criminal records of all nations show more male than female criminals. He reaches the conclusion that, after all explanations are allowed, 'the effect of sex itself on crime is permanent.'

An excellent and still more thorough analysis of this important question is presented by Miss Frances Alice Kellor in the *International Journal of Ethics*, October, 1898. She inclines to the opinion that the less criminality of women is largely apparent only, and, to the extent that it really exists, finds its full explanation in sociologic conditions and in biologic facts, not essentially dependent on sex. In other words, that woman's apparent lesser criminality is not due to inherent moral superiority, but to diminished temptation and opportunity for criminality. Most careful students of ethnology will certainly agree with this.

##### THE PROGRESS OF ANTHROPOLOGY.

THE President of the Anthropological Section of the British Association this year was Mr. E. W. Brabrook. His address was a review of some of the most striking recent contributions to anthropologic science.

These were the *Pithecanthropus* discussion, late palæolithic finds in France and England, the study of folk-lore, the mythologies of primitive peoples, the growth of religions and the progress of the Ethnographic Survey of Great Britain.

It is gratifying to see that in several passages he fully recognizes the uniformity of action in the human mind, and pertinently asks: "It does not surprise us that the same complicated physical operations are performed by far distant people without any communication with each other; why should it be more surprising that mental operations, often not so complex, should be produced in the same order by people without any such communication?"

#### A NEOLITHIC LADY.

WE should hardly expect to have a handsome and accurate portrait bust of an upper-class lady from Neolithic times. But the marvels of science do not diminish. At the last meeting—in August—of the German Association of Physicians and Naturalists, Professor Kollmann, of Basel, exhibited the bust of a female whose skull and portions of whose skeleton had been exhumed from a Neolithic grave in one of the caverns of southern France. The principles of the reconstruction, as well as modern examples of the method, prove its accuracy. The soft parts of the head and chest can be restored without risk of error.

This Neolithic dame was rather good-looking, and presented the undoubted features of the white race, demonstrating, as Professor Kollmann insisted, that empires may crumble and states decay, but the essential features of each human race persist indefinitely and unchanged.

D. G. BRINTON.

UNIVERSITY OF PENNSYLVANIA.

#### SCIENTIFIC NOTES AND NEWS.

THE American Mathematical Society will hold its annual meeting at Columbia University,

on Wednesday, December 28th. The Chicago Section of the Society will hold its fourth regular meeting at the University of Chicago, on December 29th and 30th.

THE American Physiological Society will, as we have already announced, hold its eleventh annual meeting in New York, on Wednesday, Thursday and Friday, December 28, 29 and 30, 1898. The first day's session will be held at the College of Physicians and Surgeons, 437 West 59th Street; the second day's session at Schermerhorn Hall, Columbia University, West 116th Street, partly in conjunction with the American Psychological Association; the third day's session at the University and Bellevue Hospital Medical College, 26th Street and 1st Avenue.

DR. C. WILLARD HAYES and Mr. Arthur W. Davis, experts of the Nicaragua Canal Commission in geology and hydrography respectively, have recently returned to Washington after more than a year of field work. Results of their scientific investigations are already promised for meetings of scientific societies.

DR. J. WALTER FEWKES, of the Bureau of American Ethnology, is in the field, continuing researches among the Hopi Indians.

DR. W. J. MCGEE, of the Bureau of American Ethnology, and Professor W. H. Holmes, of the United States National Museum, have returned from an ethnologic and archæologic trip through the southern Sierra region of California. Important collections were obtained for the Museum, and interesting observations were made on the surviving California Indians, while the much-discussed archæologic problems of the region received special attention. Both have promised contributions embracing the results of their work to the winter meeting of the Section of Anthropology of the American Association for the Advancement of Science to be held in New York next month.

THE *American Naturalist* states that Dr. W. McM. Woodworth has gone to the Samoan Islands in the interest of the Harvard Museum of Comparative Zoology.

AN MS. Geometry by Lobachévski has been found at Kazan and is of extraordinary interest as being of much earlier date than anything



published by the illustrious Russian. It is purposed to issue it, inserting as frontispiece the beautiful portrait from the bust of Lobachévski made by *The Open Court* from a photograph furnished by Dr. G. B. Halsted, accompanying his life of Lobachévski in *The Open Court* for July, 1898.

THE Sylvester Memorial Committee has met in London and closed its accounts. The entire amount collected was about £875. It was decided to establish a medal in bronze, to be given every three years, together with the interest on the fund for that period, for distinguished work in mathematics. Of the two appointed to collect subscriptions in America, one, Dr. Cyrus Adler, was present at the meeting in London.

THE French Minister of the Interior has awarded a bronze medal to M. Imbeaux for his contributions to hygiene. Dr. Calmette, of the Pasteur Institute, of Lille, has been made an officer of the Legion of Honor.

PROFESSOR J. MARK BALDWIN, of Princeton University, has been elected a member of the French Institute of Sociology.

DR. D. G. BRINTON is giving, at the Drexel Institute, Philadelphia, a course of lectures entitled 'The New Lands, Present and Prospective, of the United States.'

THE lecture season of the Imperial Institute, London, was inaugurated on November 14th, by a lecture on Trinidad, with some account of the recent hurricane in the West Indies, by Mr. Henry Carraciolo, the delegate from Trinidad to the recent International Zoological Congress.

THE Christmas course of lectures, specially adapted to young people, at the Royal Institution will be delivered this year by Sir Robert Ball, Lowndean professor of astronomy and geometry in the University of Cambridge. The subject will be 'Astronomy,' and the lectures, which will be illustrated by models and the optical lantern, will deal with the sun, the moon, the inner planets, the great planets, shooting stars and new methods. The first lecture will be delivered on Tuesday, December 27th, at 3 o'clock, and the remaining lectures

on December 29 and 31, 1898, and on January 3, 5 and 7, 1899.

A MEMORIAL meeting in honor of Dr. William Pepper was held at the University of Pennsylvania on November 29th. If the announcements on the program were carried out, Governor Hastings presided and addresses were made as follows: Dr. S. Weir Mitchell for the trustees of the University, Dr. James Tyson for the medical faculty and the College of Physicians, General I. J. Wister for the institution which bears his name, Daniel Baugh for the archæological and paleontological museums, Hampton L. Carson for the General Alumni Society, Frederick Fraley for the American Philosophical Society, Professor W. P. Wilson for the Philadelphia Commercial Museums and John Thompson for the free libraries of the city. Mayor Warwick will then speak for Dr. Pepper's work as a citizen.

THE death is announced of Sir John Fowler, the engineer, at the age of eighty-one years. Sir John Fowler had charge of a large number of important engineering works, but is best known for the construction of the great bridge across the Firth of Forth.

THE provisional program of the State Science Teachers' Association, for the approaching meeting in New York, is as follows:

*Thursday, December 29th.* 11:00 A. M.—Opening Session; Address of Welcome, by President Seth Low; Response by retiring President of the Association, Professor E. L. Nichols; Introduction of President-elect, Professor Chas. W. Hargitt. 11:30 A. M.—Paper by Dr. Davenport, of Harvard University, on 'Zoology as a Condition for Admission to College;' Discussion opened by James E. Peabody, Boys' and Girls' High School, New York, followed by Mr. Arthur E. Hunt, Manual Training High School, Brooklyn, and others. 2:15 P. M.—Report of Committee of Nine, by Professor Cooley. 3:00 P. M.—Union Meeting with the American Naturalists. 8:00 P. M.—Annual Address by the President. 9:00 P. M.—Reception.

*Friday, December 30th.* 9:30 A. M.—Sectional Meetings. *A.* Biology: Chairman, Professor Charles L. Bristol, of New York University; Introductory paper, by Professor G. F. Atkinson, of Cornell University. *B.* Earth Science: Chairman, Professor A. P. Brigham, of Colgate University. *C.* Nature Study: Chairman, Professor Chas. B. Scott, Oswego

Normal School. *D.* Physics and Chemistry: Chairman, Professor Albert L. Arey, Rochester. 11:30 A. M.—Paper by Dr. C. F. Hodge, Clark University, on 'The Active Method in Nature Study.' 2:00 P. M.—Paper by Mr. Arthur G. Clement, of Regents' Office, on 'The use of the Microscope in Secondary Schools.' 2:45 P. M.—General Discussion of the Report of the Committee of Nine. 8:00 P. M.—Meeting, with lecture, in the American Museum.

THE Chemical Society gave a banquet on November 11th at the Hôtel Métropole in honor of the past Presidents who have been Fellows for half a century—namely, Sir Joseph Henry Gilbert, 1841; Sir Edward Frankland, 1847; Professor William Odling, 1848; Sir Frederick Augustus Abel, 1848; Dr. Alexander William Williamson, 1848; and Dr. John Hall Gladstone, 1848. Professor Dewar, LL.D., F.R.S., the President of the Society, was in the chair, and a company of 260 guests were present. Congratulations were presented from the Russian Chemical Society and the German Chemical Society. The President, Professor Dewar, made an address to which each of the past Presidents replied. Speeches were also made by Sir William Crookes, Professor Ostwald, Lord Reay, Lord Lister, Professor Foster, Dr. Thorne, Mr. Haldane and Dr. Böttlinger.

THE opening meeting of the present session of the Royal Geographical Society, London, was held on November 14th, and was devoted to the subject of Antarctic exploration. The address of the President, Sir Clements Markham, reviewed the progress of geographical work during the year, but was chiefly directed to the subject of Antarctic exploration. He spoke of the expeditions under M. Gerlache and Mr. Borchgrevink as not likely to secure important results, but the German expedition of 1900 under Dr. Erich von Drygalski would be admirably organized under the auspices of the German government, and Great Britain would be left in the rear if it were not prepared to send an expedition to cooperate with that from Germany. He announced that the Council of the Society would subscribe \$5,000 towards the expedition. Further addresses were made by Professor Foster, Professor Rücker, Sir Joseph Hooker, Sir Erasmus Ommanney, Sir Leopold McClintock and Admiral Sir W. Whar-

ton. Since the meeting Mr. Alfred Harmsworth, the publisher, whose interest in arctic exploration has been shown by the Jackson-Harmsworth expedition, has subscribed £5,000 towards the fund.

At the monthly general meeting of the Zoological Society of London, held on November 17th, at the office, in Hanover-square, Dr. Günther, F.R.S., Vice-President, in the chair, it was stated that there were 409 additions to the Society's collection of living animals during the months of August, September and October, of which 210 were acquired by presentation, 44 by purchase, 128 received on deposit, 24 had been born in the garden and three received in exchange for other animals. It was further stated that the number of visitors to the Society's gardens during the months of August, September and October had amounted to 267,799.

THE annual meeting of the Michigan State Horticultural Society will be held in Ann Arbor, December 6th, 7th and 8th. The program includes papers by Professor Albert B. Prescott, 'Fruit Acids'; Professor Frederick G. Novy, 'Preserving Fruits'; Professor Paul C. Freer, 'Beet Sugar and Sugar Beets'; Dr. James B. Pollock, 'The Ripening of Fruits'; Professor Frederick C. Newcombe, 'What are Fruits?'

THERE will be, under the auspices of the government, an exposition of arts and manufactures in Venezuela, opening on January 1, 1900.

THE Massachusetts Horticultural Society offered a large number of prizes for the herbarium exhibition, on November 25th and 26th, at the Horticultural Hall, Boston. The premiums were given for school gardens, school herbariums and children's herbariums, the latter competition being open to all children in the State not over eighteen years old.

THE plague returns for the week ended the 11th inst show a slight increase in Bombay city. Dharwar district shows a large increase, over 2,200 deaths being reported.

DR. HAYDEN, a medical officer who visited India during the plague, arrived in Victoria in July, bringing with him plague microbes. The government, fearing a repetition of the Vienna outbreak, demanded the surrender of the mi-

crobes. This Dr. Hayden refused to do unless he received £300 compensation, and the government has, consequently, seized and destroyed them.

THE following extraordinary statement has been given to the press: "Mrs. Mary Baker Eddy, discoverer and founder of Christian Science, has just completed the examination of a class of about seventy of the active workers in Christian Science mind healing to confer upon them the degrees of the Massachusetts Metaphysical College as healers and teachers of this system of medicine, whose only crowned head is divine sovereignty, whose only priest is spiritualized man."

At the funeral of the late John W. Keely his work was eulogized and the plans of the Keely Motor Company promoted by four clergymen of the Methodist Episcopal Church. Rev. W. C. Best, D.D., said: "The wave of sorrow caused by Mr. Keely's death came to all lands and reached all shores. Thousands of investigators and scientists, though not visibly present, are gathered in spirit around his casket." Rev. W. J. Colville said: "When that mighty force shall cease suffering and poverty to cease on earth, then will statues be reared to Keely and he will be looked upon as one of the greatest men, not only of America, but of the world."

WE learn from *Electricity* that Messrs. Irving E. Burdick and Francis G. Hall, of the electrical engineering department of Yale University, have designed a submarine arc lamp of from 1,000 to 2,000 candle-power. The lamp is absolutely water-tight, with an inner and outer globe, the upper part of the outer globe being hermetically sealed to the metal cylinder containing the feeding mechanism by means of rubber gaskets and rings. The feeding mechanism in this lamp differs from that of the ordinary arc lamp in that it is enclosed in a cylinder both water- and air-tight. From the top of the cylinder, through a carefully-packed aperture, issue the two insulated wires, which, for convenience, are bound together into a cable. The lower portion of the lamp is protected by an eight-wire guard. Tests of the lamp at the depth of twenty-five feet are said to have been very satisfactory.

THE botanical expedition to the La Plata and San Juan Mountains, of Colorado, says the *Botanical Gazette*, was in the field four weeks last summer, the time being unexpectedly shortened. During that time the three collectors, Professor F. S. Earle, C. F. Baker and S. M. Tracy, secured about 25,000 specimens. Eighteen uniform sets (all sold in advance) will be distributed shortly, besides which there will be a number of partial sets (a few yet remaining unsold). It is believed that the series is more than usually valuable, both on account of the biological importance of the region and from the care exercised to secure all available forms and variations. There are also a number of new species, and quite a number of rare ones, including *Ranunculus Macauleyi* in flower and fruit, *Astralgalus Wingatensis*, *Cerastium arvense*, *Fuegianum*, *Fendlera rupicola* and others. The sets will form the basis for a report upon the season's work to be issued with the aid of Dr. E. L. Greene.

#### UNIVERSITY AND EDUCATIONAL NEWS.

THE late Edward Austin, of Boston, has given by his will \$1,100,000 for public purposes; \$500,000 is left to Harvard University, \$400,000 to the Massachusetts Institute of Technology, \$30,000 to Radcliffe College, \$30,000 to Roanoke College, and \$30,000 to the Tuskegee Normal and Industrial School. The income from these large bequests is to be used for scholarships. The sum of \$10,000 is also given to the bacteriological laboratory of the Harvard Medical School.

MR. J. N. TATE, of Bombay, has guaranteed 1,250,000 Rs per annum for advanced education in India, mainly for post-graduate study and scientific research. *The Indian Textile Journal* says: "The examples of other countries, and especially of America, have offered every encouragement;" and it is further remarked: "The systematic instruction of teachers of handicraft on an adequate scale in India has yet to be begun."

It is proposed that the bequest to Cambridge University of £10,000 by Mr. Allen, the income to be applied for a scholarship, should form the endowment of a student to be called the Allen Student, whose duty it shall be to devote him-



self to literary or scientific research. It will be awarded in alternate years in the sciences and humanities and is of the value of £250.

THE family of the late Dr. John Hopkinson, in addition to their gift of £5,000 towards the engineering laboratory at Cambridge, have given £1,600 to Owens College, Manchester, where Dr. Hopkinson was a student. The money is to be used for building a dynamo house connected with the new physical laboratory.

THE Twelfth Annual Convention of the Association of Colleges and Preparatory Schools of the Middle States and Maryland was held on Friday and Saturday at Columbia University, New York. The subjects chosen for discussion were the teaching of history and of civics in the secondary schools and the requirements for admission in engineering colleges. The discussion of the last-mentioned topic was opened by Professor R. H. Thurston, of Cornell University, who was followed by President T. M. Drown, of Lehigh University, Professor W. H. Spangler, of the University of Pennsylvania, and Professor D. G. Carhart, of the Western University of Pennsylvania. The discussion of the subject was continued by Secretary Dewey, of the Regents' Office; President Warfield, of Lafayette College; Chancellor Holland, of the Western University of Pennsylvania; Chancellor McCracken, of New York University, and President Low, of Columbia University.

THE number of students enrolled in the departments of the University of California at Berkeley is 1,565, over 150 more than at the corresponding time last year. The graduate department has an enrollment of 149 students.

THE number of undergraduate students at Oxford for the present term is 3,412, four more than last year. The number of matriculations was twenty-one greater than last year, but the B. A. was conferred on only 554 students as compared with 580 in 1897. The number of resident members of congregation is 461.

THE number of resident members of Cambridge University, both graduates and undergraduates, is this term 3,524, a decrease of twenty-one as compared with last year. The stationary condition of the two great universi-

ties, when compared with the rapid growth of the American and German universities is doubtless in a measure due to the establishment of provincial universities, but it may also in part be attributed to the fact that the educational systems of Oxford and Cambridge do not fully meet modern requirements.

THE *Journal of Education*, London, gives in its last issue some account of the extension of commercial education abroad. For some time already an annual Congress has been held of the directors of commercial schools in the Imperial Higher Commercial School at Tokio. At that held in May last, representing seventeen cities, the draft of a statute regarding industrial, commercial and agricultural education was submitted by the responsible Minister for discussion; and, in an extraordinary session of the Diet, a bill has this year been passed which allocates 119 million yens (about \$60,000,000) to the subsidizing of the intermediate commercial schools throughout the Empire. Signor Ferdinando Bocconi has placed at the disposal of the Milan Polytechnic a sum of 400,000 lire (\$80,000) for the establishment of an 'Istituto superiore di commercio,' or Commercial University, which shall have a local habitation annexed to the Polytechnic. Its aim shall be to train traders of the first rank, in view of a diploma granted for knowledge of the economic conditions and languages of the most important countries, of chemistry, commodities, commercial geography, commercial, industrial and maritime law, customs and railway legislation, banking, insurance and business methods. A project is also in hand for the establishment of a Commercial University at Moscow. It is expected that a Council will be appointed and regulations framed before the end of the present year.

OWING to the resignations, during the summer, of Dr. Henry P. Quiney and of Dr. Elisha H. Gregory, Jr., the department of histology and embryology at the Harvard Medical School, under Professor Minot, has been reorganized. Dr. Schaper remains as the demonstrator, and the following corps of assistants have been formed, the names being arranged in the order of seniority. Dr. John L. Ames, Dr. Frederick

A. Woods, Dr. Roger T. Atkinson and Dr. F. R. Stubbs. Dr. Quincy was connected with the department from its inception to the present time, and its rapid development has depended very much upon his zeal and devotion. This loss will be long regretted.

MR. F. G. HOPKINS, late demonstrator of physiology at Guy's Hospital, has been appointed to the new university lectureship in chemical physiology at Cambridge University.

#### DISCUSSION AND CORRESPONDENCE.

SHALL THE INTERNATIONAL EQUIVALENT OF 'ANLAGE' BE PRIMORDIUM OR PROTON?

TO THE EDITOR OF SCIENCE: In *Nature*, for August 25, 1898, p. 390, appeared a communication from Arthur Willey entitled 'What is Anlage?' He well remarks:

"To be obliged, on every occasion, to write 'Anlage' in inverted commas is a standing testimony to the deficiency of our scientific nomenclature and a constant offence to our æsthetic susceptibilities."\*

After pointing out the more or less obvious objections to *forecast*, *fundament* and *rudiment*, he concludes:

"The word that commends itself to me as being at once accurate and well-sounding is *primordium*, and I trust some of your readers will criticise it whether favorably or unfavorably."

I have hesitated to respond to the foregoing cordial invitation because the alternative term in the title of this note was first, in recent times, at least, proposed by me. Nearly six years ago, in an article on the Brain ('Reference Handbook of the Medical Sciences,' IX., p. 104, note), *proton* was employed to 'designate the primitive, undifferentiated mass or rudiment of a part.' It was also introduced in my review of two works on Human Embryology (*The Nation*, LVI., No. 1454, p. 350):

"One author translates *Anlage* *fundament*. The other adopts it as an English word, regardless of its multifarious and incongruous senses, the confusion that attends its pronunciation and spelling, and the improbability of its acceptance by French embryologists. Neither seems to have thought of reverting to Aristotle, whose

\*The needless adoption of German words into English had already been vigorously reproached by Schäfer. *Nature*, August 13 1896; p. 341.

phrases, τὸ πρῶτον; ἡ πρώτη ὕλη; ἡ πρώτη αἰτία, suggest the short word *proton*, already familiar in numerous compounds, and eligible for adoption into any modern language."

*Proton* was also referred to in my 'Neural Terms International and National' (*Jour. Comp. Neurology*, VI., 289, December, 1896); and in 'Some Neural Terms,' 'Biological Lectures' [Marine Biological Laboratory], 1896-1897, p. 158. It has been employed by S. H. Gage, address as President of the American Microscopical Society, 1895 (*SCIENCE*, August 23d, p. 211); by Mrs. S. P. Gage, 'Comparative Morphology of the Brain of the Soft-shelled Turtle and the English Sparrow' (*Proc. Amer. Micros. Soc.*, 1895, p. 228); by B. B. Stroud, 'The Development of the Cerebellum in Man and the Cat,' *Jour. Comp. Neurology*, V., July, 1895, p. 88; by Joseph Collins, Translation of Jakob's 'An Atlas of the Normal and Pathological Nervous Systems,' 1896, p. vii.; by C. J. Herrick, *Jour. Comp. Neurology*, IV., p. 6, April, 1894; by A. Meyer, *idem*, VIII., p. liv.; and, with editorial commendation, in the *Philadelphia Medical Journal*, May 7, 1898, p. 798. It is defined in Gould's 'Medical Dictionary.'

These uses of *proton* were evidently unknown to Mr. Willey; doubtless he was likewise unaware that the very question propounded in the title of his note had been considered in the article, 'Inquiries Regarding Current Tendencies in Neurological Nomenclature,' by C. L. and C. J. Herrick, in the *Journal of Comparative Neurology*, VII., 162-168, March, 1898. In a circular dated December, 1896, which was 'mailed to about one hundred and fifty of the leading neurologists and anatomists of the world,' was included the following item:

"Kindly underscore your preference among the following, making any comments or additions which may seem best to you: (a) *Proton*, *fundament*, *rudiment*, for the German *Anlage*."

To this query were received forty-two replies, tabulated on p. 166: *Beginning*, *origin* and *foundation* had each one American advocate; *fundament*, six (three American and three European); *rudiment*, nine (five and four); the retention of *Anlage* was favored by eleven (eight and three); but *proton* was preferred by thirteen (seven American and six European).

Had the above facts been known to Mr. Willey he would, of course, have included *proton* among the possible equivalents for *Anlage*. Were *proton* not available *primordium* would be acceptable to me. I venture to express the

hope that the shorter word of Aristotle may find favor with Mr. Willey.

BURT G. WILDER.

ITHACA, N. Y., November 18, 1898.

POST-GLACIAL CONNECTICUT.

TO THE EDITOR OF SCIENCE: A note in your issue of the 28th ult. makes my 'Postglacial Connecticut at Turner's Falls,' in the *Chicago Journal of Geology* (July-August), 'invoke the agency of ice' to cut the abandoned gorges at the Bird Track Quarry and Poag's Hole. This is just only in so far as it is true that had there been no glacier there would be no postglacial superposed gorge. The gorge, like all those of its class, was cut by the river and a clear photograph is reproduced, showing the visible water wear on these rocks in a region where all others are beautifully rounded by glaciation.

MARK S. W. JEFFERSON.

BROCKTON, MASS., November 11, 1898.

SCIENTIFIC LITERATURE.

*Handbuch der physiologischen Optik.* H. VON HELMHOLTZ. Hamburg und Leipzig, Leopold Voss. 1896. Second Revised Edition. Pp. xix+1334. M. 51; Bound, M. 54.

The phenomena of vision are so far-reaching and at the same time so organically related that they may almost be regarded as the subject-matter of a separate science. It is neither possible to include them under physics, under physiology or under psychology, nor to distribute them among these sciences. The photochemistry of the retina, the anatomical and histological data, and the comparative and evolutionary relations, add still further to the range of the subject. On vision is based one of the more important departments of medicine; for ophthalmology can in most cases not only offer a correct diagnosis, but also a cure. Probably a majority of the whole population needs its services, and if we add the hygiene of the eye, including the proper lighting of schools, the proper printing of books, etc., there is no one to whom the scientific study of vision is not of practical importance. The phenomena of vision are further factors in the production and appreciation of the great plastic arts—painting, sculpture and architecture.

Finally, the world in which we live is before all the world we see.

If there be a science of vision, von Helmholtz should be honored as its founder, and it should date from the completion of the *Physiologische Optik* in 1867. It is true, the doctrine of special creations belongs to the past. Like other departments of knowledge, vision has had a long history and a gradual development. von Helmholtz found at hand not only the greater part of the materials for his structure, but also many of the designs. From the side of physics he had the series of contributions from Kepler, Descartes, Newton, Lambert, Young, Brewster; from physiology there were Haller, Priestley, J. Müller, Plateau, Volkmann, Purkinje; from philosophy Berkeley; from art da Vinci and Goethe—to mention but a few of many names. Contemporary with von Helmholtz worked Aubert, Hering, Listing, von Graefe, Brücke, Vierordt, Donders, von Bezold and many more. But of them all von Helmholtz alone saw the range and unity of the subject, and prepared one of the few books that make an epoch. So well was his work performed that it has scarcely had a successor—only Aubert's *Grundzüge der physiologischen Optik* deserves to be mentioned—and it remained for von Helmholtz himself, in old age, with energies diverted to other channels, to write a new edition of his great work.

To give in a review an account of the contents of a book extending to 1,300 pages, written with great conciseness and covering a range of subjects so wide, is evidently infeasible. Still less possible would it be to enter into critical discussion—an article might be written on each of a hundred topics. This notice must be confined chiefly to the new edition, and the eulogy appropriate to the first edition must be tempered with criticism.

Publication of this edition was begun in 1888. In the course of about a year three parts were issued, treating of the anatomy and dioptics of the eye. About forty pages are here added in addition to substitutions for material omitted, and thorough revisions throughout. The pages in the new edition are, however, somewhat smaller than in the old. This Section concludes with the description of von Helmholtz's great



invention, the ophthalmoscope. The parts then began to appear more slowly, at intervals of about two years, until the death of von Helmholtz in 1894. The eighth part had then been completed, extending the work to page 645. The part on sensations of light runs from page 231 to page 575, being enlarged by more than one hundred pages. Much new material, especially work on intensity done in von Helmholtz's laboratory, is here added. The final part, on perceptions and judgments, mostly edited by Professor König after the death of von Helmholtz, has scarcely been altered. Professor König states that it was not the author's intention to make many changes in this part, even had he been able to continue the revision. The work concludes with an index of the literature, containing 7,833 titles, compiled by Professor König.

It seems ungracious to do other than accept this new edition of a master work with sincere thankfulness. Even though it may not as completely represent contemporary knowledge of the sense of sight as did the first edition, thirty years ago, ought we not to be truly grateful to the author for his elaborate revision? Grateful we should doubtless be and appreciative of the heroic effort of von Helmholtz. But we owe truth to the dead, and I must state my own view to be that little or nothing, or worse than nothing, has been accomplished by this revision. It has happened in cases other than this that a classic work making a remarkable contribution to science has ultimately become an obstacle to the advance of science. Kant creates a work on epistemology that alters the entire groundwork of metaphysics. After a hundred years we find the cry prevalent in Germany 'back to Kant,' and back they go, not only to the *Critique* as representing the best thought of the eighteenth century, but as though all its trivialities were of contemporary importance.

The *Physiologische Optik*, the publication of which was begun in 1856 and completed in 1867, is one of the few classics in the history of science. It summarized the existing state of knowledge with rare completeness and lucidity, and made remarkable original contributions to the advancement of knowledge. But a work of such magnitude and genius actually prevents

the preparation of new books truly reflecting the present conditions and conflicting claims of facts and theories. The physicist, the physiologist, even the psychologist, is apt to regard the gospel according to Helmholtz as infallible. This is the inevitable, against which even the gods do not contend. But the publication of a new edition dated 1896 tends needlessly to prop up the Procrustean bed, confining the growing members. Since 1860 the doctrine of evolution has been established; since 1860 modern psychology has been developed. The '1896' on the title-page is harmful to science; unfair to von Helmholtz himself.

Even the title of the book is an anachronism. Physiological optics correctly describes only that part concerned with the eye as an optical instrument. Optics is a department of physics and no longer includes the psychological phenomena of vision. When von Helmholtz himself prepared a little later a work on the sense of hearing, in many ways a companion volume to that on vision, he did not call it *Physiologische Akoustik*, but *Tonempfindungen*. The literature on vision prior to 1867 is small compared with that subsequent. Thus on the perception of color 163 titles are given in Professor König's bibliography as published earlier than 1867, and 1034 between that and 1894. The newer literature is scarcely incorporated, and in so far as this is attempted a false perspective is given by devoting many pages to work done by Professor König, Dr. Brodhun and others in von Helmholtz's laboratory, while work of equal importance done elsewhere is ignored. The injustice done, for example, to Hering, is very great. In various points of conflict von Helmholtz replies to Hering, but in such an inadequate fashion as to show either carelessness or a complete lack of appreciation of the value of evidence. The possibility that he might be wrong or that progress had been made seems scarcely to occur to him.

I may note two of these points of difference between Hering and von Helmholtz—the perception of color and the perception of space—to illustrate the tenacity with which von Helmholtz clung to his early views in spite of accumulating evidence against them. The Young-Helmholtz theory of color-vision is well known, being, in fact, imposed annually as ascertained

truth on thousands of students in their introductory courses of physics and physiology. When von Helmholtz elaborated the hypothesis it was of great value in coordinating the then known phenomena and in giving a basis for further research. But forty years have brought many changes, and if the hypothesis were now proposed anew by an unknown man it would not find a single adherent. No modern student of organic evolution can conceive how the three-fiber mechanism could develop from a unicellular organism already sensitive to light. No psychologist can conceive how three kinds of fibers make us see three primary colors as white light; they would more probably lead us to see white light as three colors, I should suppose. All the newer phenomena—the spectrum of faint light, color-blindness, contrast, after-images, the variations in the field of vision, etc.—not only do not support the hypothesis, but must be subjugated to it by unlikely subsidiary hypotheses. The phenomena of space perception are too complex to enter into here, but the ‘empiristic’ theory, of which von Helmholtz was properly proud in the sixties, seems now, after the writings of James, Ward, Stumpf and others, particularly naïve.

With some reluctance I must state that not only are the theories of the *Physiologische Optik* in large measure outgrown, but that in many cases the observations cannot be verified. In subjects in which I have myself worked—after-images, the discrimination of intensity, conflict of the fields of vision and others—new methods have given different and probably more correct results. This is the natural course of science. The work of a great investigator, if vital, must be the ladder by which we climb, but which we afterwards discard. The *Physiologische Optik* is still a great storehouse of facts and observations of contemporary importance, but we should regard it as closed thirty years ago.

The bibliography compiled by Professor König is an extremely useful piece of work, but I see no adequate reason for appending it to the *Physiologische Optik*. It may be delusive in leading the thoughtless to suppose that von Helmholtz had considered all these works; it makes the book needlessly bulky and expensive; it is compiled chiefly at second hand, with

many omissions and numberless minor errors.\* Such an index should be published separately, and, if possible, revised and brought up to date every few years.

The criticisms that I have ventured to make apply only to the revision of the *Physiologische Optik*. If the first edition had been reprinted without alteration there would be nothing to express but admiration for a work of genius almost unrivalled in the history of science, and for a man of genius whose intellect was so profound and so far-reaching that of his contemporaries only Darwin stands beside him.

J. McKEEN CATTELL.

COLUMBIA UNIVERSITY.

*Elementary Botany.* By GEO. F. ATKINSON. New York, Henry Holt & Co. 1898. 12mo. Pp. xxiii+444.

This latest and best of elementary text-books of botany is a thoroughly commendable work, and reflects high credit upon the author and upon the publishers. In pleasing contrast to the larger number of books with similar titles and kindred scope it is fresh, accurate, comprehensive and readable. It must have a heavy sale as soon as teachers of botany become acquainted with its merits, for in no other American elementary botany now before the public is the subject-matter so thoroughly covered and the illustration so illuminating and suggestive.

The text has been classified by its author under three captions, physiology, morphology and ecology, in the order given, a modification of the ordinary arrangement. In the first

\*Thus, in regard to American writers eighteen references are given to Professor Le Conte, but his book on ‘Sight’ is not included. A comparatively unimportant article by an American author is quoted three times, probably by accident. We find ‘Bowditch’ four lines after the name has been correctly given. My own name is given twice within five lines spelled incorrectly in two different ways. Mrs. Franklin’s name occurs four times, each time differently. Professor Le Conte Stevens’ name occurs five times in four different ways, never quite correctly. One of Professor Stevens’ articles is said to be in the ‘Amer. Journ. of Sc. Vol. XXIII,’ and the continuation of the article in the next number of the same journal is said to be in ‘Sill. Journ. XXIII.’ Indeed, I have noted sixteen different ways in which *The American Journal of Science* is referred to.

part protoplasm at work is the theme, and the various phenomena of cell-mechanics and cell-physiology are succinctly and skillfully described. Here are to be found the discussions of osmose, turgescence, root-pressure, transpiration, movement of liquids, diffusion, respiration, photosynthesis, growth and irritability, for all of which the splendid presentative abilities of the author are elicited. From the almost unlimited store of information to be had upon these subjects, Professor Atkinson has wisely selected, carefully condensed and tactfully eliminated so that his finished chapters bear the testimony to his unusual powers of criticism and compilation. Here and there original material is included, but always with modesty, and not at all in the far too common spirit which deems all personal results of value above any of the results of others.

In the chapters on morphology the same fine selective instinct is displayed and the completed lessons, extending over a representative series from the pond-scums to the Hawkweeds, are quite the best of their sort that have come under the observation of the reviewer. They are more than a bare enumeration of laboratory processes, more than a story about the plants and their life histories. They are a breathing, vital presentation of the principal matters of interest, structural, developmental and adaptational, which the young student should know and should remember. In the chapter on ferns the author has embodied many results of his own well-known and beautiful researches and, as elsewhere, has contrived always to use illustrations that illustrate, Figs. 231 and 232 being the only ones that can be described as inartistic, while all are scientifically adequate. The selection of types for study among flowering plants is particularly happy, and such varieties as can be obtained generally over at least the northern United States are emphasized.

The chapters on ecology are peculiarly interesting to the reviewer, since the field is one that he has attempted to cultivate, and in them many of his own results are included. Perhaps even under these circumstances he will be pardoned for speaking with something akin to enthusiasm, for certainly not even in Kerner or Warming has such a charming presentation

of the subject been accomplished. The matter is classified under the following chapter headings: winter buds, growth of woody shoots, leaf arrangement, seedlings, further studies in nutrition, dimorphism of ferns, formation of early spring flowers, heterospory, pollination, seed distribution, struggle for occupation of land, soil formation in rocky regions and in moors, zonal distribution of plants, plant communities, seasonal changes, adaptation of plants to climate. All of the chapters are finely illustrated with original figures in similligravure, including a number that are destined to become classic, as, for example, Fig. 440 of the fairy ring fungus, Fig. 484 of an atoll moor and Fig. 503 of the walking-fern. Such a series of chapters ought to renew the youth of the driest botanical pedagogue that ever droned through his Gray's Manual by the aid of an 'artificial key,' and it ought to do more for botanical instruction in the schools of America than has been done by any book since Bessey's Botany.

With so much of good to say about Professor Atkinson's 'Elementary Botany' it would be a pity to add more than the merest soupçon of unfavorable comment. A few things might have been done better. Generic names have, no doubt, as much right to their capital letters as have the honored names of the author and publishers: 'elementary botany by g. f. atkinson, published by henry holt and co.' looks absurd and so does the sentence 'comparison of selaginella and isoetes with the ferns'—at least to the eyes of the reviewer. It is a blunder to speak about the roots of *Corallorhiza*, for the coral-root orchid has no roots at all, the underground micorhizal-infested region being the rhizome. And one cannot help regretting that the author should so constantly use 'will' and 'shall' in an un-rhetorical manner, as in the beginning of paragraph 3. Paragraph 718 will scarcely do; it is neither science nor poetry. No doubt it was intended to be pictorial, but the effect is *reporter-esque*; it reminds one of the society column of the Sunday paper.

None of these trifling blemishes interferes with the general cleverness, scientific accuracy and immense utility of the new 'Elementary Botany.' The publishers are to be congratulated.



lated upon having brought out in these latter days such a virile volume.

CONWAY MACMILLAN.

SCIENTIFIC JOURNALS.

*American Chemical Journal*, November: 'On the cause of the retention and release of gases occluded by the oxides of metals:' By T. W. Richards. The author has studied the conditions under which the gases are given off and suggests a theory to account for the observed facts. 'New experiments on the quantitative synthesis of water:' By E. H. Keiser. The author has weighed the hydrogen and oxygen used and the water formed, and obtained figures which gave an atomic weight of 15.88 for oxygen if hydrogen is taken as 1. 'On the metaphosphoric acids:' By H. N. Stokes. The homologous series of compounds of the general formula  $(\text{PNCl}_2)_n$  when saponified yield acids; but the higher members do not yield acids of the same general structure as the lower ones, a fact for which the author suggests an explanation based on the Baeyer 'tension theory.' 'The ethers of toluquinone oxime and their bearing on the space isomerism of nitrogen:' By J. L. Bridge and W. C. Morgan. 'On the claims of davyum to recognition as a chemical element:' By J. W. Mallet. The evidence seems to be against the existence of this element.

J. E. G.

THE *American Naturalist* for November opens with a paper by Professor Henry S. Williams entitled 'Variation versus Heredity,' maintaining the views previously described by him in SCIENCE; Professor William Patten contributes an article on the theory of color vision described by him at the American Physiological Society in 1897 and the American Morphological Society in 1896; Professor W. J. Beal gives examples of peculiar dispersion of seeds and fruits, and Professor C. B. Davenport summarizes the advance of biology in 1896 from the *Année biologique*.

THE first number of the second volume of the *American Journal of Physiology*, issued on November 22d, contains the following articles:

'On the Excretion of Kynurenic Acid:' By Lafayette B. Mendel and Holmes C. Jackson, Ph.B.

'On the Modification of Rigor Mortis resulting from Previous Fatigue of the Muscle, in Cold-Blooded Animals:' By Caroline W. Latimer, M.D.

'On the Relation of the Blood to the Automaticity and Sequence of the Heart-Beat:' By W. H. Howell.

'On the Relation of the Inorganic Salts of Blood to the Automatic Activity of a Strip of Ventricular Muscle:' By Charles Wilson Greene.

MESSRS. ROBERT AIKMAN & Co., Manchester, announce the publication of a new periodical, '*Science Work*,' edited by Mr. Walter Jeffs. It will be issued monthly and is intended to do for science what the *Review of Reviews* is doing in a wider field. The annual subscription is only 2/6—60 cents.

AT the winter meeting of Section H, American Association for the Advancement of Science, held at Ithaca, December 28, 1897, a committee was appointed to found a journal designed to promote the interests of anthropology in America. The committee held several meetings, conferred with publishers, and reported to Section H at the Boston meeting of the Association. It has been decided to undertake the publication, provided a sufficient number of persons indicate their willingness to support the movement by subscribing for the first volume. The journal will be issued in quarterly numbers of about two hundred octavo pages, forming an annual volume of about eight hundred pages, the first number to appear in January, 1899. The subscription price will be \$4. It will embrace: (1) papers pertaining to all parts of the domain of anthropology, the technical papers to be limited in number and length; (2) scientific notes and news pertaining to anthropology, and (3) a current bibliography of anthropology. The new journal will succeed the *American Anthropologist*, of the Anthropological Society of Washington, and the name of this journal may be adopted or a new name selected—'*American Journal of Anthropology*' and '*Anthropology*.' The journal will be published by Messrs. G. P. Putnam's Sons and conducted by the following editorial board: Dr. Frank Baker, Dr. Franz Boas, Dr. Daniel G. Brinton, Dr. George M. Dawson, Dr. George A. Dorsey, Professor W. H. Holmes, Major J. W. Powell, Professor F. W. Putnam; F. W. Hodge, *Secretary* and *Managing Editor*.

## SOCIETIES AND ACADEMIES.

## BOSTON SOCIETY OF NATURAL HISTORY.

A GENERAL meeting was held November 2d, thirty-seven persons present. Professor Alpheus Hyatt exhibited the lower jaw of a whale, *Mesoplodon* sp., that came ashore on the beach inside the harbor of Annisquam, Mass., in August, 1898. The specimen was a young female; after the removal of the blubber, the length, measured along the side of the body, from the re-entrant angle of the tail-fin to the end of the lower jaw, was twelve feet, two inches. The lower jaw projected slightly beyond the upper jaw. A narrow crease was observed on the under side of the throat along the median line. The shape of the body was more or less laterally compressed oval. A single crescentic blow-hole was situated in a depression on the top of the head. The greatest diameter of the nasal pouch was about four inches.

According to True there are but two records of *Mesoplodon* from the north Atlantic coast. The first of these refers to a specimen from Nantucket, and is noticed by Professor Louis Agassiz in the 'Proceedings' of this Society, 1868, Vol. 11., p. 318. This specimen was sixteen feet long, and the skull and other bones, preserved in the collection of the Museum of Comparative Zoology, indicate a female somewhat older than the Annisquam specimen. The skeleton of the second specimen, taken at Atlantic City, N. J., in 1889, is in the United States National Museum. The skeleton of the Annisquam specimen will be preserved in the Museum of the Society.

Dr. R. T. Jackson spoke on localized stages in development in plants and animals. This paper will be printed as No. 4, Vol. 5, of the Memoirs of the Society.

SAMUEL HENSHAW,  
Secretary.

BIOLOGICAL SOCIETY OF WASHINGTON—29TH  
MEETING, NOVEMBER 19.

Dr. F. W. TRUE exhibited a copy of an entomological journal published in Japan, explaining that it was the first journal of its kind to appear in that country.

Mr. E. L. Morris narrated an extraordinary feat of climbing in the case of a small green snake, whereby the animal ascended a vertical polished nickel pipe for some distance above the tank in which it was confined.

Dr. L. O. Howard displayed three entomological posters issued in handsome form by foreign governments. Two, devoted to the Colorado potato beetle and the San José scale, were produced by the German authorities, and one, illustrating a destructive grain beetle, by the Russian.

Dr. Cleveland Abbe presented a paper entitled 'Climate and the Corn Crop,' illustrated by numerous charts and statistical tables. He discussed the various factors affecting the crop production in different portions of the country, with special reference to climatology.

Mr. Herbert J. Webber, in the course of 'A Comparison of the Types of Fecundation of Flowering Plants,' pointed out that zoidiagamous fertilization, by means of motile spermatozooids was, so far as known, confined to the Cycadales and the Ginkgoales among the Gymnospermæ. He described briefly the two forms of the process, porogamy and chalazogamy, found among the higher flowering plants, illustrating his remarks by numerous drawings of special cases.

F. A. LUCAS,  
Secretary.

HARVARD UNIVERSITY: STUDENTS' GEOLOGICAL  
CLUB, NOVEMBER 8, 1898.

Mr. W. E. HOBBS described some Cambrian fossils which he collected as East Braintree, Mass., from an outcrop that Professor Crosby places stratigraphically above the quarry outcrop. They include young individuals of *Paradoxides harlani*, shields of *Agraulus quadrangularis*, *Ptychoparia rogersi*, *Hyolithes haywardensis* (Grabau, not yet published), and an indistinct *Obolella*. Under the title of 'A new Species of Cystid,' Mr. L. LaForge discussed some specimens from the middle Chemung, at Alfred, N. Y. All the specimens, about one hundred in number, have been collected from boulders within an area of two or three square miles. The perfect specimens show the characteristics of *Agelacrinus*, but differ chiefly from the known species in the ambulacra.

*Geological Conference, November 15, 1898.*  
 MR. J. E. WOODMAN presented brief notes on two local features, 'Fifty Years' Change in Lynn Beach,' and 'A Section through the Newtonville Esker.' Thirty years ago, according to the statement of a stage driver of that time, the road across Lynn Beach, from Lynn to Nahant, was passable for the stage only at low tide. The constructive action, which has resulted in the present, broad, high beach, takes place chiefly during winter storms and on the east side. Attention was directed to some significant bedding recently exposed in a section through the Newtonville esker. The subglacial stream cut the ice on the outside of its curve, just as meandering streams cut their banks to-day, for the cast of the old channel shows higher beds unconformably overlapping lower ones on the outside of a bend.

Mr. A. W. Grabau spoke on the 'Siluro-Devonian Contact in Western New York.' In the region considered, the Onondaga limestone, at the base of the Devonian, has generally been held to rest unconformably upon the Water-lime, at the top of the Silurian. Five sections exposed in the Buffalo cement quarry, near Buffalo, N. Y., tend to show that these beds are not only unconformable, but also that they are separated, locally, by a thin layer of conglomerate. The so-called 'bull-head' limestone, which forms the upper seven feet of the Water-lime, contains few fossils except near the top, where the following have been found: exterior molds of a new coral; two species of *Lepiditida*, and five species of brachiopods. All the species show Lower Helderberg affinities. The evidence afforded by fossils and by stratigraphic position indicates that this bed is the western extension of the Lower Helderberg, and that the overlying limestone conglomerate, with quartz sand in the cement, is the equivalent of the Oriskany. Mr. Grabau proposes to call this important capping member of the Silurian the Greenfield limestone. The name is taken from the town in Ohio near which this bed both attains strong development and afforded the first fossils described from it.

One portion of the contact discussed exhibits an irregular, ancient fissure about ten feet deep and up to two feet in width. This fissure

penetrates the entire stratum of the Greenfield limestone and a portion of the Water-lime, and is filled with compact, quartz sandstone, containing angular fragments of the limestone.

J. M. BOUTWELL,  
*Recording Secretary.*

---

#### NEW BOOKS.

*A Treatise on Universal Algebra with Applications.* ALFRED NORTH WHITEHEAD. Cambridge, University Press; New York, The Macmillan Company. Volume I. Pp. xxvi + 586. \$7.50.

*Foot Notes to Evolution.* DAVID STARR JORDAN. New York, D. Appleton & Co. 1898. Pp. xviii + 392. \$1.50.

*Text-Book of Physiology.* Edited by E. A. SCHÄFER. Edinburgh and London, Young J. Pentland; New York, The Macmillan Co. 1898. Pp. xviii + 1036. \$8.00.

*Anatomy and Histology of the Mouth and Teeth.* I. NORMAN BROOME. Philadelphia, P. Blakiston's Sons & Co. 1898. Pp. viii + 428. \$4.50.

*Text-Book of Histology.* PHILIPP STÖHR. Second American Edition translated from Seventh German Edition by DR. EMMA BILLSTEIN. Philadelphia, P. Blakiston's Sons & Co. 1898. Pp. xviii + 424. \$3.00.

*Human Anatomy.* HENRY MORRIS. Philadelphia, P. Blakiston's Sons & Co. 1898. Pp. xxix + 1274. \$6.00.

*Annual Report of the Board of Regents of the Smithsonian Institution.* 1896. Washington, Government Printing Office. 1898. Pp. xliii + 727.

*Outlines of Industrial Chemistry.* FRANK HALL THORP. New York and London, The Macmillan Company. 1898. Pp. xvii + 541. \$3.50.

*Fertilizers.* EDWARD B. VORHEES. New York and London, The Macmillan Company. 1898. Pp. xiv + 335. \$1.00.

*Instinct and Reason.* HENRY RUTGERS MARSHALL. 1898. Pp. xii + 574. \$3.50.

---

*Erratum:* On page 675 above first column, line 33, for *Wabash* Creek read *Walnut* Creek.



# SCIENCE

EDITORIAL COMMITTEE: S. NEWCOMB, Mathematics; R. S. WOODWARD, Mechanics; E. C. PICKERING, Astronomy; T. C. MENDENHALL, Physics; R. H. THURSTON, Engineering; IRA REMSEN, Chemistry; J. LE CONTE, Geology; W. M. DAVIS, Physiography; O. C. MARSH, Paleontology; W. K. BROOKS, C. HART MERRIAM, Zoology; S. H. SCUDDER, Entomology; C. E. BESSEY, N. L. BRITTON, Botany; HENRY F. OSBORN, General Biology; C. S. MINOT, Embryology, Histology; H. P. BOWDITCH, Physiology; J. S. BILLINGS, Hygiene; J. MCKEEN CATTELL, Psychology; DANIEL G. BRINTON, J. W. POWELL, Anthropology.

FRIDAY, DECEMBER 9, 1898.

APPLIED SCIENCE IN THE NAVY.

## CONTENTS:

<i>Applied Science in the Navy:</i> PROFESSOR R. H. THURSTON .....	801
<i>Report on the State of the Mathematical Theory of Electricity and Magnetism:</i> PROFESSOR A. G. WEBSTER .....	803
<i>The Limitations of the Present Solution of the Tidal Problem:</i> JOHN F. HAYFORD.....	810
<i>Geometrical Optical Illusions:</i> A. H. PIERCE.....	814
<i>Some Recent and Important Experiments with the Eggs of the Sea-urchin:</i> DR. F. C. KENYON.....	829
<i>American Ornithologists' Union:</i> JOHN F. SAGE.....	830
<i>Current Notes on Anthropology:—</i>	
<i>The Map of Cuauhtlanzinco; The Variation in the Muscles in Man; Passamaquoddy Literature:</i> PROFESSOR D. G. BRINTON .....	831
<i>Scientific Notes and News .....</i>	832
<i>University and Educational News.....</i>	835
<i>Discussion and Correspondence:—</i>	
<i>A Self-adjusting Coherer:</i> A. E. LAWRENCE.	
<i>Additional Notes on an Apple Canker:</i> W. PADDOCK.....	836
<i>Scientific Literature:—</i>	
<i>Erdmann's Lehrbuch der anorganischen Chemie:</i> E. R. ANTHONY on the <i>Theory of Electrical Measurements:</i> F. E. N. UDDEN on the <i>Mechanical Composition of Wind Deposits:</i> W J M.....	837
<i>Scientific Journals.....</i>	839
<i>Societies and Academies:—</i>	
<i>The Section of Geology and Mineralogy of the New York Academy of Sciences.....</i>	839
<i>New Books.....</i>	840

AMONG the technical reports issued from the Government Press, just now, those coming from the departments of the government most active in the war with Spain are of special interest. That of the Chief of the Bureau of Steam Engineering of the Navy Department, Com. G. W. Melville, is now published, and, though brief and businesslike, gives some interesting information of a more or less scientific nature, as well as of a kind to interest the average citizen in a more general way.

The first effect of the demand upon the Department for preliminary work was to 'demonstrate in the briefest and most vigorous manner the necessities, facilities and deficiencies' of the naval establishment. Fortunately, as it proved, the already established policy of keeping at the navy yards ample stocks of material and stores reduced enormously the risks and delays, embarrassments and dangers of a sudden call for active service of every available ship and gun. Much was necessarily done, however, before satisfactory provision could be made for all emergencies; yet it will never be forgotten that the navy never failed when called upon.

Some work was performed with marvelous despatch. Thus, the old and worn-out 'shell-boilers' of the monitors *Manhattan*, *Mahopac* and *Canonicus*, at League Island, were replaced by new constructions in

thirty days. The new water-tube boilers were passed, in parts, through the hatches and the old boilers were cut in pieces below and passed up in small sections; thus saving the time, cost and risks of destruction and reconstruction of the decks which would have been necessary had the old types of boiler and ways of doing work been adopted. This necessity had been foreseen and provided for before the war actually began, and a provisional contract with the only firm known to be ready and able to undertake the task had been made. In five hours after the contract was signed the work had been commenced. The performance of these ships with the new boilers excelled the best work with the old.

The most tremendous work, in kind and quantity, was that of fitting out the auxiliary fleet of more than a hundred ships, of all sizes, kinds and duties, from tugs and ferryboats to ocean-steamers from the transatlantic lines. All were necessarily extensively altered to adapt them to their new duties, and the provision of stores, already alluded to, proved an essential element of success in securing their services promptly upon the outbreak of war. Even floating machine-shops to make repairs in the midst of the fleets were sent out and proved of inestimable value.

"There was a remarkable absence of casualty in the machinery departments of the vessels of the fighting fleet during the war. Even in action, when forced draught conditions were in operation and the excitable natures of the men most wrought upon by the surroundings, the reports show that the machinery not only worked well generally, but that in no case was it greatly distressed. This is as fine a comment upon the personnel as upon the machinery." The statement does not apply to the torpedo-boats, the condition of which, under circumstances of operation entirely unintended in their construction, 'can only be described

as horrible—boilers were burnt, cylinder-covers broken, piston and valves stuck, everything in bad shape.' This was due to absence of expert and professional supervision and to employment on duty for which these craft are not intended and for which they are unfit. No member of the Naval Engineer Corps could be spared to care for them, and the inexperienced and the inexperienced young officers in charge of the boats could not be expected to succeed in keeping their machinery in order.

The amount of work performed by this Bureau, in designing new machinery, in refitting old, in construction at the navy yards and in repairs of ships, can only be realized on reading in detail the full report. Over four millions of pounds of iron and steel passed under inspection and were shipped to points at which this material was needed. All specifications and methods of inspection and test have been revised; including physical, chemical and mechanical methods and limitations of quality. Nickel-steel has been made an important and useful material for engine-construction; steel tubes are now made without weld and wonderfully perfect. New methods of shaping and welding parts give hitherto unapproachable security in use. Steel containing an unusually high proportion of carbon is now found applicable to even steam-boiler construction. Tenacities exceeding 74,000 pounds per square-inch are attained, with extensions rising above 21 per cent., and with elastic limits above 40,000 pounds. Such gains allow reduction of sizes and parts and, still more important, in a battle-ship, diminution of weights.

Water-tube boilers are unqualifiedly approved for naval purposes, and experience with those of the *Marietta*, while accompanying the *Oregon* on the long 14,000-mile voyage around Cape Horn, proves the reliability of such boilers when properly made and handled. The experience confirms the

results of test in foreign navies also. Nearly all naval vessels, at home and abroad, now include in their specifications the water-tube boiler. "The tactical importance of water-tube boilers has been emphasized by the conditions which obtained in the blockade at Santiago and the great victory of July 3d. It was necessary, for a long period, that our ships should be ready to develop maximum power at a few minutes' notice; and with cylindrical boilers this involved keeping all the boilers under steam, with heavily banked fires and a large attendant consumption of coal. Water-tube boilers of the proper kind, which admit of the rapid raising of steam with safety, remove this difficulty and give the commanding officer a more complete command of his fighting machine." Giving great power with small weight, this modern apparatus of power-production is coming into use on all torpedo boats and, as a rule, on even the heavy battle-ships.

The steam turbine is referred to, but with the statement that it is not yet certain that it will find permanent place in the naval service.

The use of oil-fuels is pronounced prominent in some naval work where costs of fuel are not of prime importance. Success is met with in the use of an oil of S. G. 0.85 to 0.87, a flash-point of 315° Fahr., and a burning point of 350° Fahr. This oil is entirely safe on shipboard.

Referring to the marvellous performance of the *Oregon*, her long voyage, perfect condition at its end, and later effective action with the squadron off Santiago, a record 'which has never been equaled in the history of navies,' and attributing this fact to the admirable work of designers and constructors, and still more, if possible, to the splendid character of the personnel of the engineer-department of the ship, the Engineer-in-Chief says: "For the past ten years it has been my duty and a sad one to call

attention to the urgent need of a reorganization of the personnel of the Engineer Corps." Its enlargement, provision for proper selection of its officers and professional training, and of suitable inducements to men of talent and genius in this branch to enter the corps, are vitally important and necessary amendments to existing provisions for its support. An efficient Engineer Corps is as essential to the efficiency of the navy as good war-engines. The engineer and his war-engine together make victories like those of Manila and of Santiago possible, with the no less essential aid of good 'men behind the guns.' The whole department is one of applied science of the most extensive and imposing character and an Engineer Corps, scientifically educated and systematically trained to its peculiarly exacting and responsible work, is the most pressing need of the 'new navy.' The report, and its conclusion regarding the lessons of the war, is most instructive from both scientific and the political standpoints.

R. H. THURSTON.

REPORT ON THE STATE OF THE MATHEMATICAL THEORY OF ELECTRICITY AND MAGNETISM.

IN considering the state of the mathematical theory of electricity and magnetism at the end of the first half-century of the existence of this Association, it seems hardly possible to avoid a comparison with the state of affairs at the beginning of that period. In 1848, strange as the statement may seem, most of the great discoveries in electricity had been made. Coulomb had by his remarkable quantitative experiments with the torsion-balance and the proof-plane set the law of inverse squares once for all upon its feet, and thus opened the way for the wonderful applications of the analysis of Laplace, Poisson, Gauss and Green. The experimental discovery by Oersted of



the action of the electric current upon the magnetic needle had aroused the enthusiasm of Ampère, with the result of the swift production of his discovery of the laws of electro-dynamics and their representation in mathematical form, by a process of reasoning characterized by Maxwell as 'perfect in form and unassailable in accuracy.' Within the next decade Faraday and Henry had independently discovered the phenomena of induction, and thus completed, with two exceptions, the list of epoch-making discoveries in the science. We may remark in parenthesis that the dynamo and the electric motor, which have wrought such a change in our city and Association in very recent years, were thus possible before the birth of the Association.

Not only had the quantitative laws of induction of currents been formulated by Faraday, but they had been obtained by a remarkable mathematical process by Neumann, using the then hardly recognized principle of the Conservation of Energy. The mathematical theory of the subject was accordingly in a well advanced state fifty years ago. It is to be noticed, however, that all the work then done had been on the basis of action at a distance, the existence of which was then unquestioned by mathematical physicists.

Not so, however, by that prince of experimental philosophers, Michael Faraday. Not less important for the theory of electricity than his discovery of current induction were his electro-static researches by which he first showed that the forces between electrically charged bodies were not independent of the surrounding medium. Thus Faraday was led to concentrate his attention upon the medium instead of upon the charges themselves, and daringly to attack the notion of action at a distance. In order to clothe his ideas in an intuitional geometrical form, Faraday introduced the idea of physical lines of force, an idea that

was long in having its fruitfulness recognized by others.

It was not until 1861 that the note was struck which has produced such a remarkable change in the theory of fifty years since. In Maxwell's papers on 'Physical Lines of Force' in the *Philosophical Magazine* of that year he gave Faraday's ideas a mathematical garb, and introduced to the mathematical world the theory that the energy was resident in the medium, rather than in the charged bodies. In 1865 appeared in the *Philosophical Transactions* Maxwell's chef-d'œuvre, the elaborate development of his ideas in his paper on 'A Dynamical Theory of the Electromagnetic Field.' Here we find for the first time the application of Lagrange's dynamical equations to obtain in a systematic and logical way the laws of electricity and its connection with magnetism. Besides the notion of the localization of energy, both electric and magnetic, in the medium, we find the other idea, foreign to the old theory, of the magnetic action due to time-variations of the electric field, these variations being termed by Maxwell displacement currents. It is not a little remarkable that Faraday had considered the possible changes taking place in the electrical state of the dielectric medium by changes of the magnetic field, and had attempted to make them experimentally evident, but without success. Whether Faraday contemplated the effect of the changes of the electrical state on the magnetic field I am not able to state. At any rate the introduction of this hypothetical magnetic effect of the displacement currents by Maxwell gave rise to a hitherto unlooked-for possibility, namely, the establishment of an electro-magnetic theory of light. This theory not only enjoyed the advantage of novelty, but was free from the fundamental difficulties of the previous dynamical theories of light, in that in it no longitudinal wave appeared.

If Maxwell's theory was true, then experimenters should discover the magnetic effect of the displacement current. We may well imagine that for many years investigators were devising means to accomplish this result; but if this was so, they were not rewarded by success. However, a crucial question had been agitated, for, according to Maxwell, electrical and magnetic disturbances must be propagated with a finite velocity, and the theory of action at a distance must be doomed.

Before passing to the post-Maxwellian, or, as we may call it, the modern era, it may be convenient to state Maxwell's theory as he left it.

Electrical changes are related, not to the so-called field intensity, whose components are  $X, Y, Z$ , derivable from a potential  $\psi$ ,

$$(1) \quad X = -\frac{\partial \psi}{\partial x}, \quad Y = -\frac{\partial \psi}{\partial y}, \quad Z = -\frac{\partial \psi}{\partial z},$$

but to a new vector, called the electric displacement, and denoting the state of polarization discovered by Faraday. The components of this,  $f, g, h$ , are proportional to the components of the field,

$$(2) \quad f = \frac{K}{4\pi} X, \quad g = \frac{K}{4\pi} Y, \quad h = \frac{K}{4\pi} Z,$$

where  $K$  measures a physical property of the medium, Faraday's specific inductive capacity.

The density of the charge then is derived from the displacement by the equation

$$(3) \quad \rho = \frac{\partial f}{\partial x} + \frac{\partial g}{\partial y} + \frac{\partial h}{\partial z}$$

Similarly in magnetism we are to consider two vectors, the field  $\alpha, \beta, \gamma$ , derivable from a potential  $\Omega$ ,

$$(4) \quad \alpha = -\frac{\partial \Omega}{\partial x}, \quad \beta = -\frac{\partial \Omega}{\partial y}, \quad \gamma = -\frac{\partial \Omega}{\partial z},$$

and the induction, proportional to it,

$$(5) \quad a = \mu\alpha, \quad b = \mu\beta, \quad c = \mu\gamma,$$

where  $\mu$  measures another physical property

of the medium. Maxwell here puts however

$$(6) \quad \frac{\partial a}{\partial x} + \frac{\partial b}{\partial y} + \frac{\partial c}{\partial z} = 0$$

so that the analogy with the electrical equation (3) is not quite perfect.

To the equations previously accepted giving the relations between the current density  $u, v, w$ , and the magnetic field produced by it,

$$(7) \quad \begin{aligned} 4\pi u &= \frac{\partial \gamma}{\partial y} - \frac{\partial \beta}{\partial z}, \\ 4\pi v &= \frac{\partial a}{\partial z} - \frac{\partial \gamma}{\partial x}, \\ 4\pi w &= \frac{\partial \beta}{\partial x} - \frac{\partial a}{\partial y}, \end{aligned}$$

Maxwell adds the effect of the displacement currents, so that he has

$$(8) \quad \begin{aligned} 4\pi \left( \frac{\partial f}{\partial t} + u \right) &= \frac{\partial \gamma}{\partial y} - \frac{\partial \beta}{\partial z} \\ 4\pi \left( \frac{\partial g}{\partial t} + v \right) &= \frac{\partial a}{\partial z} - \frac{\partial \gamma}{\partial x} \\ 4\pi \left( \frac{\partial h}{\partial t} + w \right) &= \frac{\partial \beta}{\partial x} - \frac{\partial a}{\partial y}. \end{aligned}$$

The induced electromotive-forces due to changes in the magnetic field are represented by Maxwell in a somewhat peculiar manner, as the negative derivatives of a new vector called the vector-potential, so that

$$(9) \quad P = -\frac{\partial F}{\partial t}, \quad Q = -\frac{\partial G}{\partial t}, \quad R = -\frac{\partial H}{\partial t},$$

The vector-potential is related to the magnetic induction by the equations

$$(10) \quad \begin{aligned} a &= \frac{\partial H}{\partial y} - \frac{\partial G}{\partial z}, \\ b &= \frac{\partial F}{\partial z} - \frac{\partial H}{\partial x}, \\ c &= \frac{\partial G}{\partial x} - \frac{\partial F}{\partial y}. \end{aligned}$$

Thus the vector-potential itself does not appear, but only its time-derivatives.

The vector-potential was introduced by Maxwell to denote what Faraday termed the electro-tonic state of a body undergoing induction of current by magnetic changes.

Strangely, as it now seems, the ideas of

Maxwell were slow in gaining acceptance. We must not omit to notice that in 1867 an electro-magnetic theory of light was developed by Lorentz, but it was deduced from different considerations. It was not until the appearance of Maxwell's treatise, in 1873, that the attention of Continental thinkers seems to have been drawn to the new views. Already, however, had begun the appearance of that series of papers by the master hand of Helmholtz, which, beginning with a powerful exposition of the old electro-dynamical theories, led by successive steps to the development of a theory similar to that of Maxwell, which, as the life of the great German drew to a close, became completely adopted by him. Otherwise, however, there is little to chronicle on the Continent until the appearance of the treatise of Mascart and Joubert, over a decade later than Maxwell's, showed that the seed had not fallen upon stony ground. Let us accordingly return to England, whither the center of gravity of the mathematical development of the subject was now transferred.

The first paper to appear in the *Philosophical Transactions* on Maxwell's theory was fifteen years later, by Fitzgerald, in 1880, on the 'Electro-magnetic Theory of the Reflection and Refraction of Light.' Here we find an extension of the suggestion made by Maxwell that the magnetic energy of the field contains terms depending on vortical motions about the lines of magnetic force, and thus an attempt is made to explain the phenomena of reflection of light from the surface of magnets, discovered by Kerr.

In 1881 followed a paper by Niven on 'The Induction of Currents in Infinite Plates and Spherical Shells,' the former being a subject which had been investigated by Maxwell. In 1883 the subject of electrical motions in spherical conductors was treated by Lamb, who, however, makes the simplifying hypothesis that the velocity of propa-

gation of the inducing effect is infinite, that hypothesis not materially conflicting with any experiments then made. In 1884 appeared a paper by Larmor on the same subject.

In 1884 appeared a very important paper by Poynting on 'The Transfer of Energy in the Electro-magnetic Field,' where, by a direct application of Maxwell's theory, it was shown how the route taken by the energy in its passage from one plate to another during variations of the field could be described by the statement that the energy flowed everywhere perpendicularly to both the electric and magnetic field-vectors, at a rate proportional to the area of the parallelogram constructed on their geometric representatives. Thus, according to Poynting, the energy passes from a dynamo to a motor not through the wires connecting the two, but through the air, being guided in its course, however, by the wires. The ideas of Poynting were extended by Wien in two papers in *Wiedemann's Annalen* in 1892, as well as in a paper by J. J. Thomson, on 'Faraday Tubes of Force.'

In 1885 we have a still more important paper by J. J. Thomson, on 'The Application of Dynamics to Physical Phenomena,' in which, not especially the electrical ideas of Maxwell are developed, but rather the method introduced by him of applying Lagrange's equations is extended to a great number of phenomena. Singularly enough the same sort of methods were soon to be used by Helmholtz quite independently for similar purposes.

In 1887 Lamb attacked the more difficult problem than that of the sphere of ellipsoidal current sheets, treating as a special case the flow of currents in a circular disc, and in 1888 the problem of induction of currents in shells of small thickness was treated by Burbury. The flow of current in cylindrical conductors has been treated by J. J. Thomson and Lord Rayleigh. In



all these researches upon current-flow, interesting questions regarding partial differential equations were treated, but much is still left for the mathematician to do. In fact, it was in this same year, 1888, that a striking sensation was produced in the scientific world by the publication of the experimental researches of a new genius, Heinrich Hertz, who produced in the laboratory the electrical waves conceived by Maxwell, and for the first time confirmed the theory by demonstrating the finite velocity of propagation. Experimental papers now succeeded each other with astonishing rapidity, confirming one point after another of the theory, and the experiments of Hertz immediately obtained a vogue which has not yet subsided. The energies of mathematicians were now taxed anew, for the question of the nature and period of the electrical motions in the curiously shaped 'oscillators' used by Hertz and his followers to produce the waves became very important. The previous investigations already described did not cover the case even for spheres and ellipsoids, for, in the case of vibrations of the rapidity now experimentally realized, the effect of the displacement currents could no longer be neglected nor could the velocity of propagation be considered infinite, while the phenomenon of radiation of energy from the conductor into space demanded mathematical recognition and treatment. This it failed to get, except in an approximate manner, for anything except the simplest case, that of the sphere. This was treated by J. J. Thomson and Poincaré. Nevertheless, the theory has not been experimentally verified for the sphere, because the sphere is a badly-shaped conductor for experimental purposes. In order to retain energy enough to maintain the vibrations for a number of oscillations, the conductor should be long or even dumb-bell-shaped, and not at all like a sphere.

The long spheroid is then next to be

attacked, and then other surfaces, perhaps those obtained by the revolution of the curves known as cyclides. The introduction of suitable curvilinear coordinates into the partial differential equation concerned,

$$\frac{\partial^2 \phi}{\partial \mu^2} = a^2 \Delta \phi$$

will lead, even in the case of the spheroid, to new linear differential equations analogous to but more complicated than Lamé's, and will necessitate the investigation of new functions and developments in series.

The remarkable experimental skill shown by Hertz is not his only title to our admiration. His inaugural dissertation had been a treatment of the flow of electricity in spheres, and his electrical researches received a fitting completion in two mathematical articles in which Maxwell's theory was systematized and stated in an extremely clear and symmetrical manner. The equations of Maxwell, stated above, are unfortunately lacking in symmetry, and certain questions that have since arisen were not contemplated by him. These improvements were made in a very satisfactory manner by Hertz, as we shall describe later. We can not, however, award to Hertz the credit of priority in this matter, for the work had already been done by another writer, of whom I must now speak at length—I mean that extraordinary Englishman, Mr. Oliver Heaviside. Of this undoubted genius I feel that it is no exaggeration to say that he understands the theory of electricity probably better than anyone else now living. Of a decidedly eccentric personality and mode of expression, unknown to and unseen by most of his scientific countrymen, this self-taught luminary appeared on the horizon over twenty years ago, and slowly but surely approached the brilliancy of a star of the first magnitude. Unnoticed at first, he forced himself upon the attention of physicists by the sheer quantity of his pro-

ductions, and it was then found that their quality was also exceptional. His writings have mainly dealt with a quite different sort of subject from those enumerated above, and have treated either the flow of variable currents in wires or the transmission of electro-magnetic waves in free space. As early as 1876, in a paper modestly entitled 'On the Extra-current,' he gives for the first time the partial differential equations for the propagation of current and potential along wires, and treats them by the methods of Fourier. Later he considers the most complicated questions caused by the terminal conditions involved by the introduction of various sorts of electrical apparatus, such as those used in telegraphy and telephony. These papers will well repay the attention of pure mathematicians, to whom they offer a host of questions for rigid treatment. For instance, to fix the ideas, we have the equation of propagation

$$a \frac{\partial^2 \phi}{\partial t^2} + b \frac{\partial \phi}{\partial t} = c \frac{\partial^2 \phi}{\partial x^2}$$

with the condition that for two or more given values of  $x$ ,  $\phi$  is to satisfy given linear ordinary differential equations in  $t$ , and that for a given value of  $t$ ,  $\phi$  and  $\frac{\partial \phi}{\partial t}$  are to be given functions of  $x$ .

If we attempt to satisfy the equation by particular solutions which are trigonometric functions of the time we get an ordinary differential equation in  $x$ , and if we then make use of trigonometric functions of multiples of  $x$  the multiples allowable will be determined by certain transcendental equations according to the terminal conditions. The function  $\phi$  is then to be developed in a series of such trigonometric terms. The nature of the proofs desired relating to the series may be readily inferred. The papers by Heaviside are extremely numerous and bulky, and it is desirable that the methods there used should receive critical attention

from mathematicians, for it must be said that Heaviside uniformly disdains such things as existence-theorems, depending chiefly on his intuitions drawn from physical reasoning.

A large portion of Heaviside's labors has been devoted to the systematization and extension of Maxwell's theory and the attempt to disseminate a knowledge of that theory among the physical public. His results agree so nearly with those of Hertz that I shall give them in the notation and form used by the latter, which seem to me preferable. The attempt to bring out the symmetry or reciprocity between electrical and magnetic phenomena has been paramount with both Heaviside and Hertz. Accordingly, we have for the connections between the electric and magnetic field intensities, represented respectively by  $X, Y, Z$  and  $L, M, N$ , and the corresponding inductions or polarizations  $\mathfrak{X}, \mathfrak{Y}, \mathfrak{Z}$  and  $\mathfrak{L}, \mathfrak{M}, \mathfrak{N}$ ,

$$(11) \quad \begin{array}{l|l} \mathfrak{X} = \epsilon X & \mathfrak{L} = \mu L \\ \mathfrak{Y} = \epsilon Y & \mathfrak{M} = \mu M \\ \mathfrak{Z} = \epsilon Z & \mathfrak{N} = \mu N \end{array} \quad (12)$$

instead of equations (2) and (5),  $\epsilon$  representing the specific inductive capacity and  $\mu$  the magnetic permeability. For the electrical and magnetic densities  $\rho_e$  and  $\rho_m$  we have

$$(13) \quad \rho_e = \frac{1}{4\pi} \left\{ \frac{\partial \mathfrak{X}}{\partial x} + \frac{\partial \mathfrak{Y}}{\partial y} + \frac{\partial \mathfrak{Z}}{\partial z} \right\},$$

$$(14) \quad \rho_m = \frac{1}{4\pi} \left\{ \frac{\partial \mathfrak{L}}{\partial x} + \frac{\partial \mathfrak{M}}{\partial y} + \frac{\partial \mathfrak{N}}{\partial z} \right\}.$$

For the mutual connections of the two fields we have

$$(15) \quad \begin{array}{l} 4 \pi u + \frac{\partial \mathfrak{X}}{\partial t} = \frac{\partial N}{\partial y} - \frac{\partial M}{\partial z}, \\ 4 \pi v + \frac{\partial \mathfrak{Y}}{\partial t} = \frac{\partial L}{\partial z} - \frac{\partial N}{\partial x}, \\ 4 \pi w + \frac{\partial \mathfrak{Z}}{\partial t} = \frac{\partial M}{\partial x} - \frac{\partial L}{\partial y}, \\ - \frac{\partial \mathfrak{L}}{\partial t} = \frac{\partial Z}{\partial y} - \frac{\partial Y}{\partial z}, \end{array}$$

$$(16) \quad \begin{aligned} -\frac{\partial \mathfrak{M}}{\partial t} &= \frac{\partial X}{\partial z} - \frac{\partial Z}{\partial x}, \\ -\frac{\partial \mathfrak{N}}{\partial t} &= \frac{\partial Y}{\partial x} - \frac{\partial X}{\partial y}. \end{aligned}$$

Thus, with the exception of the electrical currents  $u, v, w$  on the left of equation (15) and the negative sign in (16), we have complete analogy between the electrical and magnetic equations. In these equations neither the electric nor magnetic potentials nor the vector potentials appear, and we are concerned only with the two field intensities, which have a more tangible existence than the potentials. While equations (15) are identical with (8), equations (16) take the place of (9) and (10), for if we differentiate equations (10) according to the time, and substitute on the right for the time-derivatives of  $F, G, H$ , their values from (9), we obtain (16).

In order to obtain the result of propagation with finite velocity, let us consider a non-conductor, where  $u, v, w$  are zero, and let us suppose  $\epsilon, \mu$  to be constants. Differentiating the third of equations (16) according to  $y$  and subtracting from the second differentiated according to  $z$  gives

$$\begin{aligned} \frac{\partial}{\partial t} \left\{ \frac{\partial \mathfrak{N}}{\partial y} - \frac{\partial \mathfrak{M}}{\partial z} \right\} &= \frac{\partial^2 X}{\partial x^2} + \frac{\partial^2 X}{\partial y^2} + \frac{\partial^2 X}{\partial z^2} \\ &- \frac{\partial}{\partial x} \left\{ \frac{\partial X}{\partial x} + \frac{\partial Y}{\partial y} + \frac{\partial Z}{\partial z} \right\}. \end{aligned}$$

Substituting the value of the parenthesis in the left from the first of equation (15), after making use of equations (11) and (12) and assuming that the parenthesis on the right vanishes, since there is no free electricity, gives

$$\epsilon \mu \frac{\partial^2 X}{\partial t^2} = \frac{\partial^2 X}{\partial x^2} + \frac{\partial^2 X}{\partial y^2} + \frac{\partial^2 X}{\partial z^2},$$

which is the equation for the propagation of waves, as we have it in the theories of sound and light. The velocity of propagation is  $\frac{1}{\sqrt{\epsilon \mu}}$ .

The last paper of the series of Hertz treats of the equations to be used in connection

with moving bodies, and besides introducing terms accounting for the remarkable discovery by Rowland of the magnetic effect of a moving charge of electricity suggests several matters not yet verified by experiment. Still deeper into the theory goes an elaborate paper by Heaviside on the 'Forces, Stresses and Fluxes of Energy in the Electro-magnetic Field,' published in the *Philosophical Transactions* of 1892. In this paper Heaviside deals with matters which are still open to controversy.

The last contributions of Helmholtz to the theory were his paper on the 'Principle of Least Action in Electrodynamics,' published in 1893, in which he seeks to deduce all the electrical equations from this fundamental mechanical principle, and his paper on the 'Electro-magnetic Theory of Dispersion,' in which he adapts his beautiful explanation of this complicated optical phenomenon to the electro-magnetic theory.

I have time here only to mention researches on electro- and magnetostriction, or change of form and shape of bodies in electric or magnetic fields, to which contributions have been made by Helmholtz, Boltzmann, Kirchhoff, Stefan, Lorberg, Adler, Cantone and Duhem, and on the magnetic effects produced by the motion of electrical charges, upon which subject papers have appeared by J. J. Thomson, Heaviside and Searle.

Before closing I must, however, mention several elaborate papers by Larmor, begun in the *Philosophical Transactions* for 1894, in which the attempt is made to propound a dynamical theory of the ether, which shall not only give a suitable explanation of light, but also a dynamical theory of all electric and magnetic phenomena, including the electro-magnetic theory of light. For this purpose the old theory of McCullagh is found to be available and is developed with extremely interesting results, while a great variety of phenomena are dealt with.



I have here made no mention of the work that has been done on the various theories of the mutual actions at a distance of current elements, as these are thoroughly dealt with in J. J. Thomson's admirable British Association report on electrical theories in 1885. I have thus, in a very brief and unsatisfactory manner, merely touched upon some of the principal points of the development of the theory of electricity, and traced its gradual but unceasing progress from the hands of the giants of the old days to those of the new.

ARTHUR GORDON WEBSTER.

CLARK UNIVERSITY.

THE LIMITATIONS OF THE PRESENT SOLUTION OF THE TIDAL PROBLEM.

THAT which is new in science is always interesting. But it is well at times to let the old and well-tried pass in review before us, to plan renewed attacks upon the unknown, in the light of the elements of strength or weakness found in different portions of the army of known facts and principles, and with respect to the stubbornness of the resistance which has been encountered by attacks upon different parts of the unknown. A helter-skelter attack may perhaps produce more interesting and more surprising results than a well planned campaign, but the latter would be expected to furnish the more important results. The purpose of this paper is not to state anything new, but to point out a very weak point in tidal theory, a point which it is important to have strengthened, and of which the strengthening is apt to lead to a decided advance in our knowledge of the subject.

The thesis which I submit is that the present theory of the tides upon the earth when used to explain those tides, or to predict their occurrence at a particular point, furnishes very little except the *periods* of the separate harmonic, or invariable,

components of the tide. It does not furnish the times of occurrence of the tides, that is, the epochs of the components, nor does it furnish the range of the tide as defined by the amplitudes of the harmonic components.

This thesis may be exhibited in concise form by writing the algebraic expression for the height of the tide referred to mean sea level at any instant at a given point

$$h = A_1 \cos (a_1 t + \beta_1) + A_2 \cos (a_2 t + \beta_2) \dots$$

Each term of this expression indicates one of the harmonic components of the tide. From pure theory, reasoning from the known motions of the Moon, Sun and Earth and the Newtonian law of gravitation, it has been shown that if certain definite values be assigned to the quantities  $a_1, a_2, \dots$  (fixing the periods of the separate terms), that each term truly represents one of the invariable components of the tide. Here, after *merely* fixing the periods of the separate components the contribution of tidal theory ends, and the work of direct observation at the particular station under consideration begins. The values of  $A_1, A_2$ , defining the amplitudes of the separate components and the range of the composite tide, and of  $\beta_1, \beta_2, \dots$  fixing the epochs of the separate components and the time of the tide, must be derived directly from observations at the particular station in hand. Their values cannot, at present, be assigned even approximately from theory.

If we look at the *actual* tidal problem presented to us by Nature the reason why theory furnishes so little will become evident. In approaching the actual problem let us begin by considering a simple ideal problem which can be and has been successfully handled, and then introduce into this problem, one by one, the *actual* conditions which modify it. In doing so we may, to a certain extent, follow the historic order of tidal research.

There are tides produced by both the Moon and the Sun. To avoid circumlocu-

tions we will deal explicitly with the lunar tides only.

We may start with the problem of determining the shape of the free ocean surface on the supposition that the Earth consists of a rigid nucleus completely covered with a great and uniform depth of water and upon the supposition that the Moon moves in a circular orbit in the plane of the Earth's equator at such a rate that one face of the Earth is always presented to the Moon, just as the Moon now always presents the same face to us. Roughly speaking, the ocean in this case would become an ellipsoid with its major axis in the line joining the centers of the Earth and Moon, and this tide, if we may call it so, is the so-called static or equilibrium tide. This problem has been completely solved.

As a next step toward the actual problem, let the Moon be supposed to remain in a circular orbit in the plane of the Earth's equator, but let its period in that orbit be twenty-seven days, as at present it is. The Earth now presents different parts to the Moon in rapid succession as the Earth rotates once on its axis in each solar day. At once the problem becomes much more difficult than before; for the effects of viscosity of the water, of its inertia and of friction against the ocean bottom combine to reduce the height of the wave, to modify the shape of the wave, to cause its crest to lag behind the Moon. The problem is now that of dealing with a *forced* wave—a much more difficult one than the static problem just outlined, and more difficult than that of dealing with a free wave. But it is still a problem which has been so thoroughly investigated that there is comparatively little hope for a new worker to extend our knowledge much along this line.

The introduction of the actual Moon with its rapid changes in declination and distance, and its variable motion in right ascension, in the place of the fictitious Moon

we have been considering, makes the problem heavier, but not essentially much more difficult.

From the theory of wave motions in liquids it has been shown that for a wave, such as the tidal wave, of which the length from crest to crest is great in comparison with the depth of the water, the rate of progress of the wave is connected with the depth by the law  $V = \sqrt{gh}$ , in which  $V$  is the velocity of progress of the wave,  $g$  the acceleration due to gravity and  $h$  the depth of the water. According to this law a free tidal wave would succeed in keeping pace with the Moon in its apparent progress around the Earth only in case the assumed uniform depth of the water is greater than thirteen miles. If the uniform depth be assumed less than thirteen miles the old wave will, in effect, be continually being lost in the race and a new wave be continually being built up in front of it. The tide of our previous problem will be still further reduced in range and modified in shape and will lag still further behind the Moon, which produces it. The problem is still tractable, though exceedingly difficult, and still falls in the category of thoroughly investigated problems.

Now let the problem become nearer like that of Nature by supposing the shape of the surface of the solid portion of the Earth to be just what it is in fact, an irregular succession of great continental elevated areas, great oceanic basins, mountain ranges, broad valleys, great plateaus, etc. Let the problem still differ from that of Nature by supposing that the water level is just high enough to cover the summit of Mt. Everest, so that the whole Earth is covered with depths varying from zero, at Mt. Everest, to ten miles, on a few small areas at the deepest portions of the oceans. If, under these conditions, an attempt is made to follow the history of the wave in its westward progress, the problem will at

once be found to be exceedingly difficult, if not intractable, though the problem is still much simpler than that presented to us by Nature.

The depths being everywhere less than thirteen miles, the wave will at no point be able to keep pace with the Moon. The apparent rate of progress of the Moon over the Earth's surface is about seventeen miles per minute. The rate of progress of the wave will be about fifteen miles per minute where the depth is ten miles, and less than five miles per minute where the depth is not greater than one mile.

Let an attempt be made to trace a tidal wave westward, starting from the 180th meridian in the Pacific. The northern portion of the wave will be confronted by the full width of both Asia and Europe; the middle portion will have deep water across the Indian Ocean, but will be obliged to cross submerged Africa before reaching the Atlantic; while the southern portion will have unobstructed deep water to and beyond the Cape of Good Hope. This southern portion, rounding the Cape of Good Hope, will necessarily be propagated northward up the Atlantic, as well as westward, for the middle portion, travelling in shallower water, will not yet have reached the Atlantic. The middle and northern portions of the wave will have acquired an irregular front on account of the various depths traversed by different portions. This Cape wave, as it progressed northward up the Atlantic valley, would combine at an angle in some complex fashion with the irregular wave emerging gradually from the shoals of Africa, and finally from Europe. In short, even with the conditions so far imposed, it would be exceedingly difficult, if not impossible, with our present knowledge, to compute the wave to be found in the Atlantic, to say nothing of the additional complexity produced when this already complicated wave crossed the submerged Americas.

Still we are dealing with a problem very much simpler than that of Nature. In the actual case the Moon would outstrip the wave in its westward progress, and then the direct effect of its attraction would be to tend to tear down the old wave and build up a new one in advance of it. This action would bring about radical modifications in the wave, even within one trip around the globe.

Moreover, the variations in depth produce other effects upon the wave fully as important as the one just considered. The increased friction in small depths tends to reduce the height of the wave. On the other hand, when a wave passes from deep to shallow water there is a tendency for the wave to attain a much greater height than before, since nearly the same amount of kinetic energy must be concentrated in a much smaller amount of water. So a tidal wave continually varies between wide limits in amplitude, as well as in its rate of propagation, in a way that is exceedingly difficult, to say the least, to compute. These variations in range produce obvious difficulties in such a case as that just suggested, in which waves from different regions coalesce.

As one more step in making our assumed problem approach the actual problem, let the water surface, which has been supposed to be at the level of the summit of Mt. Everest, subside to its present actual position. One-fourth of the earth's surface becomes dry land. There is now in the problem all the previous intricacies, and in addition a new set of difficulties, arising from the fact that the oceans are bounded by irregular shores, from which the tidal wave is reflected to a greater or less extent at every point of contact. The actual tidal waves may as properly be compared to a choppy sea, such as may be seen along the docks of a crowded port, as to a regularly progressive wave passing to westward around the



earth, as pictured in the minds of most people.

Tracing the actual tidal wave as best we can by direct observation, we find that by starting at a point off the west coast of South Africa the wave is separated into two waves, one of which goes westward and the other eastward. If we follow that portion of the wave which has the least obstructed path, passing across the open Pacific to the southward of Australia and to the Cape of Good Hope, we find that after *thirty-six* hours it has not yet circumnavigated the globe, but instead has just reached the neighborhood of Cape Horn and is there apparently lost in a collision with an *eastward-bound* tidal wave, which started in the Pacific, off the west coast of South America, twenty-four hours later than the wave which we have followed. Looking to other portions of the oceans we find that the tidal wave moves northward rather than westward over the whole Atlantic and a part of the Pacific—in fact, on about one-third of the total ocean surface; and that the progress has a decided *eastward* tendency in at least two large areas, in the Arctic ocean north of Europe, and in the Pacific off the west coast of South America.

If we examine the relative amplitudes of the harmonic components of the tide at different stations we shall find further strong evidence of the radical modifications made in the astronomical tide by the influence of shores and bottom. As a typical case we may note that in the Atlantic the semi-diurnal components are large as compared with the diurnal components, so that there are always two tides of nearly the same height per day, whereas in the Pacific the amplitude of the diurnal components approaches that of the semi-diurnal components and in some cases exceeds it, and as a result the two Pacific tides of the same day are in general of decidedly different heights and in certain extreme cases but

one tide occurs per day. In one of the extreme cases, at Batavia, Java, the component which has *one* high water per *sidereal* day is more than six times as large as the component having two high waters per lunar day, although in the astronomical tide the latter predominates over all others.

Out of the conflict with the shores and bottom the astronomical tide preserves only its periods, and hence in making tidal predictions at a given station theory can furnish us nothing but said periods. In the conflict no period is lost, though the amplitudes corresponding to certain periods may be greatly decreased or increased, and no new periods are known to be produced save certain multiple periods, or overtones, so to speak, produced by friction, and an annual period fixed probably in the main by meteorological causes.

When the prediction is made it applies to *one point* only, the point at which the observations were made, and with our present lack of ability to predict the effect of boundaries upon the range, the shape, and the rate of progress of the tidal wave that prediction can be extended even by careful study of charts but a very few miles from the stations of observation before acquiring large errors.

The effects of the boundaries—bottom and sides—can best be studied in bays and rivers, in bodies of water in which observations are available at many points, and in which the direct effect of the Moon and Sun is small as compared with that of the wave transmitted from the ocean. The tide tables and charts issued by the Coast and Geodetic Survey furnish many fine opportunities to study this problem. For example, the charts issued by that Survey give complete and detailed information as to soundings in the Chesapeake Bay and its tidal tributaries, and the tide tables give complete harmonic data for Old Point Comfort, Baltimore and Washington, and data

as to time and mean range of tide for forty-nine other points on Chesapeake Bay, and for twenty-eight points along the Potomac River, to say nothing of sixty-one points on other tributaries of the bay. For such a region the investigator has an ample collection of facts to be used in proving or disproving any theory which he may formulate.

I am inclined to think that whoever successfully attacks this problem will use a graphic, or partially graphic method, plotting his results step by step upon the chart. In any wholly analytic method it will be especially difficult to take sufficiently into account the configuration of the bottom and shore.

In conclusion, I submit that to solve this boundary problem is to make an immense stride in our knowledge of the tides, a stride corresponding to a half century of ordinary progress; that it is in this line that our ignorance of the tides is most dense; that the facts are at hand for the investigation, and that, judging from the literature of the tides, this is, *comparatively speaking*, an unworked portion of the field. Along this line considerable pioneer work has been done, especially along purely mathematical lines, but the new comer will find neither a long series of failures to discourage him by indicating that the problem is intractable, nor a long series of successes to discourage him by making it appear that there is little opportunity to advance beyond what has already been done by others.

\* \* \* \* \*

It may seem that in this paper some attention should be paid to the fact that theory furnishes the relative amplitudes of certain harmonic components; that, in particular, theory indicates that certain relations exist between the relative amplitudes and the mass of the Moon, and that this theory has been born out by the fact that said mass has been computed with a

high degree of accuracy from tidal observations.

It should, however, be kept clearly in mind that only the *relative* amplitudes are concerned in the computation of the Moon's mass. Further, the mass of the Moon as deducted from observations at a single tidal station is often largely in error. An accurate determination of the mass is obtained only when the results of observations at many stations are combined.

There is a decided significance, in the present connection, in the conclusions reached by two investigators who have carefully studied this phase of the tidal problem. Professor Ferrel, after a prolonged consideration of the matter, concludes that, to secure a better determination of the Moon's mass from the tides, a special study of 'shallow water components' should be made. In other words, the effects of friction due to the boundaries must be studied. Professor Harkness, in deriving the Moon's mass from tidal observations,\* gives all stations equal weight, though the length of the series of observations varies at the different stations from one to nineteen years, on the ground that 'the accidental errors at any station are generally small as compared with those due to constant causes.' He indicates in the context that these 'constant courses' are constant for each point, but variable in passing from point to point along a coast; in other words, they are due to the local peculiarities of the boundaries.

JOHN F. HAYFORD.

#### GEOMETRICAL OPTICAL ILLUSIONS.

DURING the last few years the subject of Optical Illusions has been receiving a degree of attention that may well be called remarkable. Both popular and scientific articles have been written, so that the general public, as well as the specialist, is well

\* On the Solar Parallax and its Related Constants, Wm. Harkness, pp. 119-120.

informed about the simplest forms of the most interesting types of illusion. The signal for the scientific discussion of the subject seems to have been given in 1889 when Müller-Lyer first published the 'figures' which now bear his name. The investigations and discussions that grouped themselves about these particular figures soon spread to the whole field of optical illusions, until there grew up that body of technical literature which to-day has assumed very respectable dimensions. It is not so much that new forms of illusions have been devised or discovered—although more than one valuable contribution has been made—as that the heretofore well-known illusions have been subjected to a closer scrutiny than ever before. Like everything else accessible to experimentation, illusions have been taken into the laboratory. Variants, possessing characteristics that differ somewhat from the original form, have been devised. Each figure has been dissected and analyzed that it might be reduced to the lowest terms. And, above all, each figure has been subjected to a quantitative investigation, the amount of the illusion being accurately measured under the widest possible variety of conditions. These results in turn have been made the basis of theoretical considerations, and the end sought has, of course, always been some satisfactory *explanation* which shall furnish adequate grounds for the presence of an illusion in any given case. It is here that the war has waged. For while, in general, there has been sufficiently close agreement in reference to the results of experimental observation, there has been small uniformity in the theoretical conclusions reached. The one great attempt of to-day is, therefore, to bring harmony into this field; to establish, if possible, some single point of view which shall be applicable to all geometrical optical illusions alike, and which shall furnish that wished-for, comprehensive unity among the

seemingly scattered and unrelated facts. That this attempt has met with complete success can hardly be asserted. Theories fundamentally antagonistic stand side by side with others that seek to combine and reconcile, and the day of perfect agreement seems yet distant enough. The splendid attempt of Wundt\* to connect all illusions with actual or attempted *movements of the eyes*; the no less earnest attempt of Thiéry† and Filehne‡ to establish an explanation in terms of *perspective*; the classic attempt of Helmholtz and, more recently, of Heymans§ and Loeb to apply in one form or another the principle of *contrast*, and the very pretensions effort of Lipps¶ to define and utilize an *aesthetic* principle of unrestrained and victoriously striving activities, or their opposites, are all cases in point.

Perhaps the clearest way to give those readers of SCIENCE who, while interested in the subject, are unable to follow the technical literature closely and at first hand, some impression of the more recent work that has been done, will be to consider, in the first place, the discussions that have centered about some of the best known illusions, leaving until the end the account of the various explanatory principles that have been advanced and vigorously defended.

#### A.

1. *Zöllner's Pattern*.—In one or another of its many forms every one is familiar with the illusion of Fig. 1, in which a set of parallels is made to appear alternately convergent and divergent, by the addition to them of transverse cutting lines. But

\* Wundt. *Die geometrisch-optischen Täuschungen*, 1898.

† Thiéry. *Philosophische Studien.*, XI and XII.

‡ Filehne. *Zeitsch. f. Psych.*, etc., XVII (1898): 15.

§ Heymans. *Ditto.*, XIV., 118.

¶ Lipps. *Raumesthetik u. geometrisch-optischen Täuschungen*, 1897.



familiar as this figure is, discussions in regard to the principles that should be applied to its explanation are by no means at an end. Two theories, especially, are at present contending for the primacy: the one, namely, falling back upon the supposedly

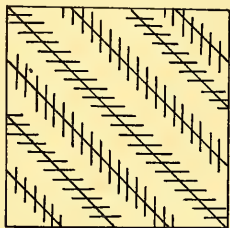

FIG. 1.

fundamental principle that when acute and obtuse angles come together in the field of view the former are relatively overestimated, the latter underestimated; the other appealing to perspective principles and calling attention to the fact that the above figure is to be seen, not as lying wholly in the plane of the paper, but as presenting elevations and depressions, projecting ends of lines and well-defined ridges. The first theory is well enough understood to render extended comment unnecessary. Suffice it to say that the main lines, rather than the short transversals, are affected by this false estimation of angles for the very obvious reason that they form in each case the common side of a multitude of angles. For a long time this theory was content to stand in this simple form. But the plastic phenomena of the figure, which we shall have to consider in a moment, are to-day too evident to be lightly disregarded. Hence the most recent statement of this theory\* takes full account of the prospective phenomena present, but relegates them to a secondary position, making them dependent

\* Wundt., Op. cit.

upon the already present deflections of the main lines.

In sharp contrast to this are the claims of the second theory. For its perspective influences are primary and all-sufficient. The observations, made long ago by Hering and Guye, to the effect that a careful attention to the figure will reveal unmistakable plastic characteristics, are here again emphasized. Especially if the above figure be drawn upon glass and viewed against a uniform background, the tri-dimensional properties become clearly apparent.\* Not only do the ends of the main lines run alternately above and below the plane of the drawing, but, further, the transversals seem so to slope that if prolonged they would meet in ridges similarly above and below the plane. Accordingly, the illusion is due to the *interpretation* that we give the figure. We see the actual parallels projected, as it were, upon the surfaces of solid and hollow prisms which lean away from the vertical, and the lines being actually parallel the observer must interpret the more remote ends as diverging, as would actually be the case in ordinary perspective vision. In other and more general terms, the preponderatingly tri-dimensional character of all our visual experience compels us to interpret in the light of this every perspective motive that any linear drawing may contain. In the figure before us the arrangement of lines recalls by association certain real experiences with similar elements, and forthwith all the attributes that would be given to the lines and parts of a real seen object are given to the linear drawing, even though the observer be not consciously aware of anything beyond the final perception which turns out to be illusory.

Such in mere outline are the two opposing theories which to-day seem likely to

\* The observer should always remember that the perspective elements of any figure are most clearly seen when *one* eye only is used.

arouse discussion most seriously. To be sure, there are other theories in the field, but they may perhaps remain unmentioned here. How these two theories fare when they descend to details we must consider later.

Attention has been called recently in a very interesting way to certain phenomena of movement that are to be observed upon the heavy original Zöllner pattern shown in Fig. 2.\* In his *Physiologische Optik*

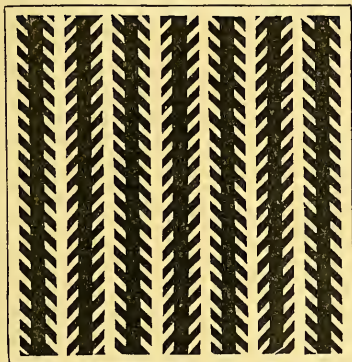

FIG. 2.

Helmhóltz called attention to certain facts that appear to be less universally known than their importance would seem to justify. He noticed that if any small object, as the head of a pin, be steadily fixated while drawn horizontally across this diagram the heavy verticals appear to be set into motion in the direction of their own lengths, adjacent lines moving in opposite directions. The necessary rate of movement for the fixated point can be determined readily for each observer. If this motion be from left to right those lines bearing upward running transversals will seem to shoot upwards, those bearing downward running transversals downwards, and if the carefully fixated point be moved back

\* Filehne, Loc. Cit.

and forth over the diagram a most startling unsteadiness is produced in it. Now the movements recently noticed by Filehne are very similar to these in appearance. They are to be seen thus: Placing the diagram so that the main lines lie horizontally, view it, not too fixedly, through a tube blackened within. Movements of diagram and tube being obviated in some way, a few moments' careful gazing will reveal the fact that the horizontals, two, three or more at a time, are darting about to the right and left, during a period of from one to three seconds. The motion of any particular horizontal is seen to be always in the direction of the overhanging ends of the obliques. Though it is affirmed that these phenomena may be seen even when the possibility of eye-movements is excluded, the writer finds slight movements absolutely essential, such, for example, as are produced by beginning to close the eye. Though most easily seen, perhaps, when the lines of the diagram are placed horizontally, these movements are none the less to be seen in the vertical position. Those lines that before darted to the left now pass upwards. If placed in an oblique position a peculiar fact may be noted. If the lines run upwards from right to left the observed motion will be upwards for those lines that before moved to the left and upwards respectively. But if the lines run upwards from left to right no motion is to be seen, since, while the tendencies to motion found in the horizontal and vertical positions have reinforced each other in the first oblique position, they are such as to cancel each other here. But in any case, whenever motion occurs, it takes place in the direction of the overhanging ends of the obliques. The reason for these phenomena Filehne claims to find in the consideration of 'memory-images of motion.' His theory is supplementary to the general perspective theory of which he is an earnest advocate. Many of our visual

experiences are had while we are in motion. In such cases the angle made by any upright object that is perpendicular to the earth changes as we approach it or recede from it. This change is always of such a kind that, as we approach, the angle appears to diminish from an obtuse to a right angle, and as we reach and pass beyond the object the angle seems to increase, the perpendicular appearing, that is, to fall gradually away from the moving observer. But whether the observer be approaching or receding, the apparent movement—which may be regarded as a rotation about the point of contact with the ground—is always opposite to the direction of the observer's progress, and always towards that position where it shall seem to tip away from the observer as he has passed by. Most strikingly, possibly, is this seen in railway travel. The telegraph poles seem to rotate as they fly past, and always in the direction of that position where they shall appear to overhang. Well, countless experiences of this kind have stored up such a mass of memory-images that when, as in the Zöllner diagram, similarly overhanging obliques are viewed, these latent images are brought to the threshold of consciousness and the diagram itself becomes enlivened with an illusory motion, occurring in strict accord with actual objective experience. Psychologically considered, the language used is not wholly free from objection, but the meaning of the theory is on the whole clear enough. It has seemed well to report these new observations at some length, since their importance for the theory of optical illusions is evident. Filehne asserts the complete lack of connection between the illusory movements described by himself and those mentioned by Helmholtz. To the writer, however, it would seem that the two sets of phenomena are very closely related. Whether this be so, only a careful and more extended examination of the

matter can determine. The alleged movements, or their lack, are too difficult of observation and too elusive of rigid verification to admit of any positive statements at present. Nevertheless the question may be asked very pertinently, how any visual impression, of whatever characteristics, should be capable of causing illusory perceptions of movement at a moment when every actual movement of the eyes is excluded. Certainly, if the observations recorded be true, we have something novel in the realm of psychology—a perception of motion, but a motionless object and a motionless eye.

2. *The Poggendorff Illusion.*—The secondary illusion to be seen on the oblique lines of the heavy Zöllner pattern, the more usual form of which is shown in Fig. 3, still continues to be the object of experimental and theoretical inquiry. We meet here the same contrasted theories as before, though we find them somewhat less sharply stated.

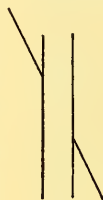

FIG. 3.

The explanation that rests upon the overestimation of acute angles has, as usual, little difficulty with the matter. The free ends of the transversal are simply rotated about the points of contact with the verticals, with the result that a new line may be drawn at either end in apparent continuation of the other. It would seem also, as Wundt has pointed out, that other factors cooperate to produce the illusion, since its amount is much diminished by giving the figure a horizontal position. One such factor is doubtless the universal tendency to overestimate the upper as opposed to the lower half of any vertical dimension. Another factor may well be the likewise universal tendency to underestimate empty as opposed to filled spaces. Underestimating the open space between the inner ends of



the transversal would result in an apparent narrowing of the vertical strip and a consequent increase of the illusion. But this latter factor is probably effective here in a minimum degree.

Somewhat more interesting is the perspective explanation. This we meet under two different forms. The first employs the usual perspective argument. Carefully viewed, the ends of the transversal may be seen to issue from the plane. This becomes especially evident if the figure be made of wire and suspended before a uniform background. In consequence of this perspective quality of the figure the visual angle made by the transversal and the vertical is interpreted as *representing* an angle of greater magnitude than that seen, just as in the case of all angles seen perspectively in objective vision, and the illusion results. This, if I rightly understand him, is the argument of Thiéry. The second form of the perspective explanation differs quite materially from this. It is the explanation of Filehne. According to this the vertical strip of the Poggendorff figure serves principally to sunder the two ends of the transversal to such a degree that there is no longer any sufficient reason for regarding them as belonging together. Now, remembering that, in accordance with the perspective theory in general, the lines of a plane geometrical figure act chiefly as the means of suggesting real objects of actual experience, we can easily see the line of thought. For there is not the remotest necessity that two detached portions of a straight line represent objects whose bounding edges should appear continuous, merely because they would meet and form a continuous line in the linear drawing that represents them. It can be most readily and graphically shown by straight-line drawings of objects that two detached portions of one and the same line may represent objects in totally different planes of

space, so that if the objects represented were to be prolonged in their own direction they might never meet at all, or at best only at an oblique angle. In the figure before us, consequently, it is highly probable that the sundered portions of the oblique recall some real experience, or set of experiences, in which the objects represented are absolutely unconnected. Such an experience may be suggested by a finger-post, an arm upon one side pointing obliquely towards the observer, an arm upon the other side—lower or higher, as the case may be—pointing obliquely away. Herr Filehne finds great support for this view in the alleged observation that every trace of the illusion vanishes in the above figure if only the two verticals be somehow united, or if some indications be present to show that the ends of the transversal are portions of a continuous whole, the missing part of which is hidden behind the vertical strip. The first condition can be secured by drawing within the latter a short line which shall be oblique to the transversal and meet the edges of the strip at points opposite those in which the ends of the transversal terminate. The second condition can be readily secured by making the transversal represent a pointed stick, or by placing at the outer ends of the transversal the drawing of some such device as weights and pulleys, which shall make it clear that the two ends are really acting in unity. But though these conditions be fulfilled to perfection, the illusion simply does *not* vanish, despite the assertion of Filehne to the contrary, nor would one expect it to do so. For what these particular devices are expected to accomplish is the closer approach to the actual conditions of tri-dimensional vision, where only one interpretation of the lines is possible. The best conditions for testing the theory would be found, therefore, in normal objective experience. Stretch a rope obliquely behind a tree trunk and at a distance of

some feet from it. The illusion persists, and yet there is no possible attempt to give an independent perspective interpretation to either end of the rope. Still more conclusive, perhaps, is the consideration of the so-called 'Illusion of the Gothic Arch,' a representation of which is given in Fig. 4.

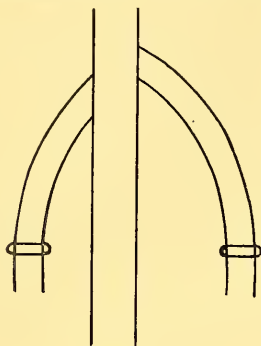

FIG. 4.

This illusion, many times independently observed, is manifestly but a variant of the more simple rectangular form, and its striking quality is not destroyed even though the observer be most intensely conscious that he is in the presence of actual objects, seen under the conditions of normal perspective. It seems most necessary, therefore, to look askance at this most recent attempt to apply the perspective interpretation to the Poggenдорff figure.

One point seems to have been universally overlooked in the quantitative investigations made upon this figure. All measurements, namely, so far as one can judge from the literature of the subject, have proceeded upon the assumption that the amount of the illusory displacement is to be discovered by moving one end of the transversal vertically along the strip, the moving line to be kept always *parallel to itself*, until the point is reached where the

two parts seem continuous. It would seem, however, that an unprejudiced approach to the problem should lead one to make room for any possible *angular* displacement that might be required to bring the moving end into a position of satisfactory apparent continuation with the fixed end. The writer recently constructed an apparatus which allows the determination of both vertical and rotatory displacement, but the meager results thus far obtained give no basis for any conclusion in the matter. Still the point seems well worthy of more extended attention.

3. *The Müller-Lyer Figure.*—Figure 5 presents in its typical form the much-discussed

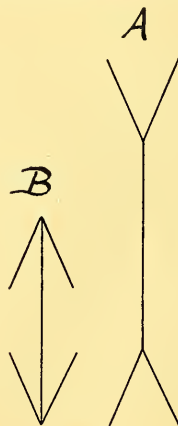

FIG. 5.

'optical paradox,' first published by Müller-Lyer in 1889, in the *Archiv für Physiologie*. No less than eight different explanations for this illusion have been propounded and warmly defended by the various writers. This number has been so far reduced by the reciprocal overthrow of the contesting parties that only three attempts at an explanation need detain us here. (a) The *perspective* theory is less fortunate here than usual.

According to it the principal line of *A* in the above figure is seen to be more distant from the observer than the principal line of *B*. The tiny obliques, that is, run forward from the point of contact in the former and backward in the latter. In consequence of this difference in apparent distance between the two lines, the dimensions of the figure must be apprehended in accordance with the universal law, that of two objects subtending the same visual angle that will be perceived as the greater which is projected to the greater distance from the eye. The perspective form, particularly of *A*, can be most easily seen where the ends of the obliques have been connected by straight lines; that is, when the whole figure has been enclosed in a rectangle. But now immediately the *equivocal* character of the figure becomes manifest. It may be seen, namely, either as an oblong hip-roof in miniature or as a hollowed out, crib-like object. In other words, the principal line may be made to appear now nearer, now more remote from the observer. Though less apparent, the same equivocal character is to be observed in the normal figure, *B*. But, whether nearer or more remote, the *apparent length of the principal line does not change*, and, since there are no compelling grounds to determine once and for all that *A* shall be seen in the distance and *B* in the foreground, the perspective explanation ignominiously fails, its whole structure being based, as we have seen, upon an *equivocal* perspective reference.

The other theories mentioned are the 'confluxion-contrast' theory of Müller-Lyer, and the 'muscular energy' theory of Delbœuf and Wundt. (*b*) *Confluxion* is the term used to designate a class of facts where the estimated lengths of lines partake of the nature of the surrounding space in so far as this is indicated by other lines lying immediately adjacent. That is, the principal line of *A* is estimated as longer than that of *B*, be-

cause the total space inclosed by *A* is greater than that inclosed by *B*. Confluxion differs from contrast in that for the former any line *shares in* the characteristics of its surroundings, while for the latter any line assumes characteristics *opposite* to those of its surroundings. Here both motives are influential, confluxion as indicated, and contrast in so far as the principal line comes into comparison with the short obliques. This, in a word, is the 'confluxion-contrast' theory. Confluxion must evidently play the more important rôle in the present case. But an examination of this principle of explanation reveals the fact that its unreliability makes it very dangerous of acceptance. Cases can readily be found where, if true, the principle should be, but is not, effective. The most simple case is perhaps that given by Wundt (Fig. 6), where according to the

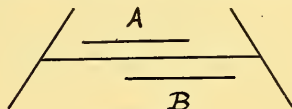

FIG. 6.

theory *B* should appear longer than *A*. Some further theory seems requisite, therefore, to satisfactorily account for the illusion.

(*c*) Though the forms given to the 'muscular energy' theory by Delbœuf and Wundt are by no means identical in respect to details, yet for purposes of description they may be brought together. Wundt has given by far the best statement of the theory. Its essence is that our visual spatial estimates are always influenced, if not first made possible at all, by the amount of energy expended by the muscles of the eye in running the point of regard over the figure viewed. The strength and range of this theory we can first see when later we examine the several principles of explanation. Meanwhile the statement will suffice that the tendencies to move the eyes beyond the



end of the principal line of *A*, and similar tendencies to fall short of the ends of the line in *B*, bring it about that the vertical of *A* is perceived as the longer. This will be true whether the eyes move freely along the line or remain fixated upon some point placed midway between the two figures lying side by side. In the latter case the illusion will be diminished in amount, though still existing, by reason of the fact that there can still be weakened impulses of the same kind as when the eyes are in motion.

A quantitative study of this illusion has shown that for each angle made by the two obliques a maximum of illusion is reached with a particular length of oblique, on either side of which the illusion diminishes. Thus, if the principal line be of 75 mm. and the angle between the obliques be  $60^\circ$  the maximum illusion occurs when the length of the oblique equals 30 mm.\*

Innumerable forms can be given to the Müller-Lyer figures. The obliques may be replaced by fork-like ends with parallel prongs, or by circles and semicircles. Or *A* and *B* of Fig. 5 may be placed end to end in such a way that the outward pointing obliques of *A* become the inward pointing obliques of *B*, and in this condition various

that of *B*, though they are of equal length. Again, the point of bisection of the altitude of an isosceles triangle seems placed too high, the angle of the vertex acting apparently in the sense of *B*, of Fig. 5. Type founders have taken account of this in placing the horizontal of the letter *A* far below the middle.

4. *Münsterberg's Illusion of the 'Shifted Checker-board Figure.'* The illusion of Fig. 8\* differs essentially from all the foregoing, for while it resembles the Zöllner pattern in the converging and diverging character of the vertical lines its explanation rests upon a totally different principle, namely, that of *irradiation*. Fig. 8 may be called 'the illusion of the kindergarten patterns,' since it reproduces in black and white the type of patterns used in the occupation of mat-weaving. A single element of the illusion may be obtained by taking from the figure one of the vertical lines and the several pairs of overlapping rectangles that lie along it. If, further, the rectangles be changed to squares we have the form of the illusion first published by Professor Münsterberg only a few years ago in the Milton Bradley collection entitled 'Pseudoptics.' The brief assertion was there made that the illusion is due to irradiation.



FIG. 7.

combinations of obliques may be omitted without destroying the illusion. Many more complex figures may be constructed which display illusions due to the presence of Müller-Lyer motives. Fig. 7 shows two of these, the side *A* appearing longer than

This statement, however, German writers have shown themselves singularly disinclined to adopt. Heymans† and Lipps‡

\* The illusion may be best seen by holding the diagram somewhat beyond the range of most distinct vision, or by viewing it as reflected in a mirror.

† Heymans. *Loc. cit.*

‡ Lipps. *Op. cit.*, p. 319.

\* Heymans. *Zeitsch. f. Psych.*, etc., IX., 227.

have brought it into relation with the Zöllner patterns and have made use of it to show that some other principle than the overestimation of acute angles must be employed in explaining the latter, since in the new variant no acute angles are present. Filehne\* has even attempted a perspective

diagram until the angle between the line of vision and the verticals equals about  $30^\circ$ . In this position the lines of rectangles that run away from the observer seem to form each a series of low steps. Running the eye along any vertical reveals this very clearly. The reason is evident. The back-



FIG. 8.

interpretation, according to which an element of the illusion, held horizontally, represents a bench, one end of which recedes into the background. As to the latter explanation, not only does it involve the arbitrary procedure of drawing additional lines to represent the seat of the bench, or of making the squares gradually smaller in order to suggest the greater distance of one end; but, more than all, it can give no satisfactory account of the illusion when the line of squares, or rectangles, lies vertically. There is, to be sure, a secondary illusion in the figure, to which several observers have called attention, which might lead one to suspect the presence of perspective elements. Hold Fig. 8 so that the plane of the paper makes a small angle with the line of vision. Then turn the

ground, as it were, for any rectangle viewed in this way is partly a white area, partly a similar black area. These areas are so distributed that when dark area is followed by dark area the middle portion of these joined areas must seem somewhat darker than the outlying parts, since the latter have received a grayish tinge from the white areas beyond. This darker portion can be interpreted only as a part lying in shadow, and hence the illusory perception of a low step, the 'riser' being the shadowed portion.

But as surely as this secondary illusion rests upon one of the accessory criteria of perspective vision, just as little can it furnish any basis for the perspective explanation of the primary illusion. That this is due to irradiation cannot now be doubted. The present writer endeavored recently\* to

\* Loc. cit., p. 42.

\* *Psychological Review*, V. (1898), 233

show by a qualitative and quantitative study of this illusion that no factor other than irradiation need be appealed to for a thoroughly satisfactory explanation. The hesitation shown in accepting this explanation has been partly due, no doubt, to the fact that in the usual cases of encroachment by irradiation the diminished dark areas have retained outlines that are everywhere *parallel* to the original outlines of the figure. One has only to think of the dark square or circle on the light background. In the present case, however, the effective

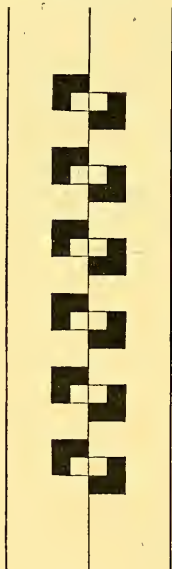

FIG. 9.

point of the irradiation is in the *corners* formed by the adjacent rectangles. The white areas *bore into* the dark corners, as it were. In this way those portions of any vertical that run along the sides of the various rectangles are deflected towards the corners, both above and below, and the de-

fections of these several portions give the tilted character to the line as a whole. This irradiation in corners is strikingly shown in Fig. 9, where the point of effective irradiation has been shifted to the centers of the incomplete squares. Here there is no longer a deflection of the vertical, but instead the bars of white that cross the line seem to slope slightly downwards to the right. The result of the qualitative and quantitative investigation above referred to showed clearly that the illusion vanishes whenever there can be secured the impossibility of irradiation in the corners situated along the line. The figures devised secured the latter condition while still retaining any factors that this figure may have in common with the Zöllner patterns. If, further, the character of the illusion in the regular figure was altered by substituting colors for the blacks and whites, or if the character of the illumination was changed by the use of the electric spark, or by the interposition of colored media between the diagram and the eye, the measurements of the illusion disclosed varying changes in the amount of apparent deflection. These results seemed to show the entire sufficiency of the explanation in terms of irradiation, at the same time rendering superfluous the appeal to, or the search for, any further explanatory principle.

5. *Loeb's Illusion.*—In 1895 Professor Loeb, of Chicago, called attention to the following interesting illusion.\* Let  $M$ , Fig. 10, be a fixed vertical line and  $a$  a shorter line parallel with  $M$  and lying to the right. Placing  $M$  in the median plane and steadily fixating some point in it, place a second line  $b$  in such a position that it shall be continuous with  $a$ . This attempt will probably succeed very well. But now being a third line in the position occupied by  $c$  in the figure  $b$  will seem to lie too far to the right. That is,  $b$  must now be brought to

\* Jacques Loeb. Pflüger's Archiv, LX., 516.



the position indicated in the figure in order to appear continuous with *a*. The lines employed may be narrow strips of black

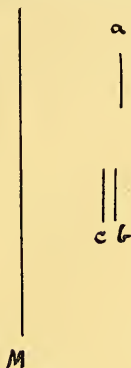

FIG. 10.

cardboard, or the lines may be replaced by coins or other objects of a similar nature. The discoverer's explanation is given in terms of *contrast*. If the space value of the impression *b* be the apparent distance of *b* from *M* we may say that this has been increased by the presence of *c*, since the resulting retinal impressions come now into the relation of 'contrast,' or of mutual repulsion, whereby the space value of *b* is increased. Accordingly *b* must be moved nearer to *M*, that its apparent space value may be equal to that of *a*. This explanation has not met with universal favor, and Heymans, Filehne and Wundt have each sought other solutions. The first attempts to unite this to the Zöllner illusion, the second to explain in terms of perspective. Wundt, in opposition to all previous attempts, points out the fact that this is an illusion of indirect vision, to be explained, therefore, only by reference to some known facts in that field. These facts he finds in the well known illusion of von Recklinghausen, in accordance with which rows of apparently

horizontal and vertical points, placed farther and farther outwards from the point of fixation and in apparent parallelism with the real horizontal and vertical passing through this point, must be made to curve slightly with the convex side towards the point of fixation. In the illusion of Loeb *b* alone can be placed correctly in line with *a*, since the impression made by the lines is sufficiently strong to overcome the tendency to the Recklinghausen illusion. The addition of *c* restores the normal conditions somewhat, however, perhaps through the impression of imaginary lines drawn from *a* to *b* and *c*; and the expected inward inclination from *a* to *b* now takes place. That Wundt's explanation is wholly clear can by no means be asserted. Still, the full recognition of the fact that this is an illusion of indirect vision, and the attempt to subsume this under phenomena already known, are long steps towards a possible explanation that may prove more satisfactory.

6 and 7. *The Illusions of Baldwin and Judd*.—At the last meeting of the American Psychological Association, held during the Christmas holidays, two reports were made in reference to recently observed optical illusions. Professor Baldwin gave some new observations made upon the illusion of Fig. 11, with which the readers of SCIENCE were made acquainted through these columns in 1896. The point actually midway between the circumferences of the two circles seems nearer the larger. So far as the writer is aware, no final explanation has as yet been proposed. In the report referred to we are simply told that *perspective* 'has probably little influence,' and that the principle of 'equilibrium' cannot account for it, since the placing of the apparent middle point is in the contrary direction to that demanded by this principle. The announcement of further experimental results is awaited with interest. Dr. Judd has called attention to an interesting illu-

sion that seems to throw some light upon the general problem of visual space-perception. Two threads are so placed in a box that they cross each other at an acute angle while lying at different depths. If one of the points of crossing be properly fixated, two phantom threads will be seen passing

planation applied to optical illusions the following theories only will be considered: namely, the *contrast* theory, the *perspective* theory and the *physiological* theory. Lipps' æsthetic theory must remain unconsidered here, its unique form demanding rather a particular treatment by itself. Let us see

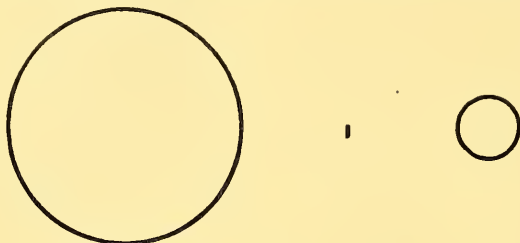

FIG. 11.

between the main threads and making with each other a figure which, if viewed from the side, would resemble an X. The directions necessary for satisfactorily securing the proper conditions for this illusion are too detailed to find a place here. The interested reader is, accordingly, referred to the article designated in the foot-note.\*

Such are the principal illusions that are being ardently discussed at the present time. To mention the numberless variants and minor illusions of form and magnitude that have come to light in the course of these discussions would be far beyond the scope of this article. The reader who cares to pursue the subject further is referred to the literature of the subject, particularly to Sanford's 'Laboratory Course in Psychology,' where may be found an excellent bibliography practically complete to the beginning of the current year.

#### B.

In attempting a brief summary of the discussions relative to the principles of ex-

how each of the three mentioned deals with the overestimation of acute angles. The *contrast* theory says that the two legs of an acute angle are in a relation of mutual antagonism, each point of one exerting a repelling influence, as it were, upon a point of the other. The consequence is, of course, that the whole angle appears larger than it really is. The *perspective* theory asserts that acute angles are not overestimated when unaccompanied with accessory lines formed by the prolongation of the legs of the angle, or otherwise. Then, and only then, the lines are regarded as *perpendicular* lines seen in perspective, and the acute angle gains therefrom an increment of magnitude. The *physiological* theory, by which that of Wundt is meant, claims that the relative magnitudes of angles depend upon the relative intensities of the muscular sensations gained by sweeping the eyes over the angle; and since for acute angles there is relatively more energy involved in the starting and stopping of the movements of the eyes, an acute angle, as compared with an obtuse, must be relatively overestimated.

\* C. H. Judd, *Psych. Rev.*, V. (1898), 286.

As to *contrast*, the illustration here given does not exhaustively express the many phases under which this principle appears. Helmholtz has a theory of direction-contrast, Heymans one of movement-contrast, and Loeb one well illustrated by the case just treated. Since, however, no one of them contains in itself any reason for its particular way of working, it becomes in each case a mere name, a convenient expression only for the fact in hand. The only legitimate application of the principle of contrast is in those cases, well illustrated by the circles of Ebbinghaus (Fig. 12),

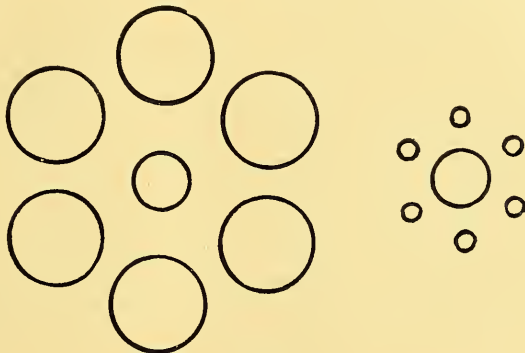

FIG. 12.

where two objectively-equal areas become apparently diminished or enlarged respectively, according as they are brought into approximation with larger or smaller areas of the same nature. In this sense of the term the fact to which the principle is applied is brought into range with a multitude of facts in every department of mental life, the general law of which is that when any mental state with certain prominent characteristics is brought into comparison with a second state of opposite characteristics the peculiar quality of each is intensified, just as a season of joy is more joyful when immediately following a season of pain.

In the monograph already referred to more than once Wundt powerfully emphasizes the fact that the principle problem of *perspective* is to determine whether its position is primary or secondary; whether, that is, it is the *cause* of the illusion in a given case or the *effect* of an already present illusion. To determine this figures are found with no accompanying perspective phenomena, though the nature of the illusion is analogous to that presented by figures with perspective phenomena. It would seem, therefore, that perspective were wholly *secondary* to some more fundamental factor.

And this presumption is strongly fortified by the fact that the perspective phenomenon is always *unequivocal*, that is, that dimension perceived as greater is always projected to the greater distance, and cannot by any effort of 'imagination' or 'will' be brought nearer. These few words give but a faint hint of the force of the argumentation in detail.

The *physiological* theory is the outcome of an attempt to discover some principle that shall be fundamental and hence capable of universal application—valid, that is, not only for 'variable' illusions of magnitude and direction, but also for such 'constant' illu-



sion as the overestimation of the upper half of a vertical. Such a theory Wundt long ago propounded. His recent work is only an especially thoroughgoing attempt, from a novel standpoint, to defend the old thesis. Especial emphasis is placed upon the consideration of equivocal figures and upon the secondary character of 'perspective.' And everywhere attention is called to the effect of particular positions and movements of the eyes. The essence of the theory is that every visual spatial perception is a complex formed by the assimilation of visual qualities with sensations coming from the muscles of the eye. Whatever, therefore, increases the intensity of the muscular sensations that enter into the complex occasions the perception of a greater spatial magnitude. The particular conditions necessary for this increase of muscular intensity are to be found both in the asymmetry of the eye-muscles and in those cases to which the general mechanical principle can be applied, that brief movements require relatively more energy than those of longer duration, since it is harder to start and stop a movement than to maintain one already under way. This theory is called 'physiological,' to call attention to the fact that the conditioning factors are of physiological rather than psychological origin. With the exception of a few cases, such as the illusion of contrast shown in Fig. 12, this principle of muscular energy finds universal applicability. One may be unwilling to accept the wide-reaching implications that this theory has for the general doctrine of space perception. Yet one must frankly admire Wundt's masterly effort at unification and acknowledge the compelling power of his argumentation, especially as it appears in this new form.

In conclusion, attention may be called to the illusion of Fig. 13, in which the oblique line *ab* appears to curve slightly at its point

of intersection with the vertical. The illusion is not marked, but it can usually be seen by all observers. For some it may be more distinct if the three figures be held

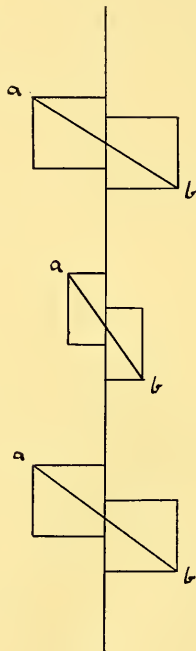

FIG. 13.

horizontally, and it may be more apparent in some one of the figures than in the other two. But if the eye carefully follow the line from *a* to *b* the line will probably be seen to bulge on either side of the point of intersection in such a way that it forms an extremely attenuated *S*. Each of the three principles of explanation considered above is applicable here. The first would say that the points of the oblique and the vertical are mutually antagonistic in the immediate vicinity of the point of intersec-

tion; the second, that perspective motives are operative in the neighborhood of the vertical, their further influence being prevented by the fact that the ends of the oblique are tied to the points *a* and *b*; the third, that the eye, in passing along the oblique, is solicited by the vertical, and the more resolute effort requisite to keep to the original path causes an apparent increase of the angle, the curving of the line being due to a conflict between the increase of the acute angles and the fixity of the outer ends of the oblique.

Which of these explanations shall we accept?

A. H. PIERCE.

AMHERST COLLEGE.

SOME RECENT AND IMPORTANT EXPERIMENTS WITH THE EGGS OF THE SEA URCHIN.

THE well-known experiments of Boveri in which egg fragments were fertilized apparently gave evidence that the union of female cytoplasm with a spermatozoan may be followed by segmentation and development, but the proof is very inconclusive. It was left for Yves Delage to complete the evidence.

In a late communication to the French Academy\* Delage states that he has succeeded in dividing the egg of *Strongylocentrotus lividus*, not *en masse* by shaking, as has been done heretofore, but by hand beneath the microscope and in such a way that there can be no doubt as to the fragments obtained being parts of the same egg. He was able to see that the nucleus was contained in one part and not in the other, which was, therefore, composed of ovulatory cytoplasm. A whole or uninjured egg was placed beside the fragments and spermatozoa introduced into the drop of water in which the experiments were performed.

Sexual attraction manifested itself with equal energy by all objects. The controle egg and the two fragments were fecundated.

A little later segmentation began, appearing first in the controle, a little later in the nucleated and still later in the nonnucleated fragment. The rapidity of segmentation was greatest in the controle and least in the nonnucleated, so that when controle was in the stage 8 or 16 the nucleated fragment had developed to stage 4 and the nonnucleated to stage 2. In the drop of water the development could not be of long duration, but in one case it was successfully carried through three days. At the end of this time the controle formed a typical gastrula. The nucleated fragment had developed so that the only difference apparent was its smaller size. The nonnucleated fragment also developed into a gastrula, but with the enteric and blastocœlic cavities very much reduced, owing, no doubt, to the smaller size of the fragment. In all cases a vitelline membrane appeared about the blastomeres. Some of the larvæ were fixed and stained, and the nuclei and nucleoli found in the cells from the nonnucleated to be no smaller than those in the cells from the nucleated fragment.

From these experiments Delage deduces the following very important conclusions:

1. The ordinary definition of fecundation must be rejected as being too strict. The union of the female and the male pronuclei certainly takes place, but it is not essential to development.

2. Fol's conclusions as to the union of the two pronuclei and of the demi-ovocenters with the demi-spermocenters must be cast aside. For, as the experiments show, the absence of an ovocenter is not an obstacle to development.

3. The theories in which fecundation is explained as the saturation of a female nuclear polarity by a male nuclear polarity must likewise be dismissed, and also those theories regarding the formation of the polar globules as for the purpose of ridding the female nucleus of all male elements.

\* *Comptes Rendus*, CXXVII., 15 pp., 528-31.

4. It is likewise necessary to reject the theories in which the male element is regarded as supplying the chromosomes subtracted in the formation of the polar globules. In giving up part of its nuclear matter the egg does not become *ipso facto* incapable of ulterior development, since an ovulatory cytoplasm provided with a number of chromosomes and a mass of chromatin equal to that which it had originally, but of paternal origin, is capable of forming an embryo.

5. Sexual attraction is not confined to the nucleus.

6. In fecundation there are two things to be considered: (a) The communication to the egg of a vital energy that permits it to segment and develop. (b) The communication to the product of advantages resulting from amphimixy and from the possession of hereditary characters.

On the second of these two questions no light is thrown by the experiments, but on the first there is, showing that the theories of fecundation reconcilable with it are those representing this phenomenon as the bearing by the male element of special energetic plasma (*kinoplasma*) contained in its sperm center.

7. There is no specific structure in the ovulatory cytoplasm, the conservation of which is a condition of development. If a structure exists it is conditioned by mutual reactions of the parts and is capable of re-establishing itself when it has been altered.

8. Boveri's celebrated experiments, so warmly contested by Seeliger, are confirmed by the removal of the most serious objection to their validity, namely, the impossibility of cytoplasmic development without a nucleus. F. C. KENYON.

#### AMERICAN ORNITHOLOGISTS' UNION.

THE Sixteenth Congress of the American Ornithologists' Union convened in Washington, D. C., on Monday evening, Novem-

ber 14th. The business meeting was held at the Army Medical Museum. The public sessions, commencing Tuesday, November, 15th, and lasting three days, were held at the U. S. National Museum, the Central High School and the Cosmos Club.

Robert Ridgway, of Washington, D. C., was elected President; Dr. C. Hart Merriam, of Washington, D. C., and Charles B. Cory, of Boston, Vice-Presidents; John H. Sage, of Portland, Conn., Secretary; William Dutcher, of New York City, Treasurer; Charles F. Batchelder, Frank M. Chapman, Ruthven Deane, Drs. Jonathan Dwight, Jr., A. K. Fisher and L. Stejneger, and Mr. Witmer Stone, members of the Council. By a provision of the by-laws, the ex-Presidents of the Union, Drs. J. A. Allen and Elliott Coues, and Messrs. William Brewster and D. G. Elliot, are *ex-officio* members of the Council.

One active, one corresponding and one hundred and one associate members were elected—the largest number in any one year except one since the Union was founded. As in the previous year, a large percentage of the new associate members were women, a direct result of the Audubon Society movement, and of the present interest taken in the study of birds by the teachers in the public schools.

Mr. Witmer Stone's paper on 'Some early Philadelphia Collectors and Collections' was of special value from a historical point of view. New facts regarding Peale's Museum, Audubon, John Cassin and the early workers in ornithology in this country were given.

Wednesday afternoon and evening were devoted to papers illustrated with lantern slides. Through the kindness of Professor W. B. Powell, Superintendent of Schools of Washington, a hall at the Central High School was placed at the disposal of the Union and its friends for the afternoon. The first communication was by Mr. Frank



M. Chapman entitled 'The Bird Rocks of the Gulf of St. Lawrence.' He was followed by Dr. Thomas S. Roberts, who gave an exhibition of lantern slides of birds, birds' nests and nesting haunts from photographs taken by himself in Minnesota. Other slides were shown by Messrs. William Dutcher and William L. Baily.

In the evening the Union met in the Assembly Hall of the Cosmos Club, by courtesy of that Club. Here three papers were read, viz.: 'On the Nesting Habits of the Brown Pelican on Pelican Island, Florida,' by Frank M. Chapman; 'Chapter in the Life of the Canada Jay,' by Oscar Bird Warren; and 'Clarke's Crows and Oregon Jays on Mt. Hood,' by Florence A. Merriam. All of the slides exhibited were effective, showing care and patience in obtaining the negatives.

Mr. Witmer Stone, Chairman of the Committee on Protection of North American Birds, read a most interesting report on the work done during the past year. The report will be published in *The Auk*, and reprinted as a separate pamphlet, to be sold at a very low price.

The graphophone demonstration of a brown thrasher's song by Dr. Sylvester D. Judd was a new and unique feature of the Congress. Dr. Judd's experiments were made with a cage bird, but the results obtained were enough to show that great possibilities in this field may be looked for in the future.

Following is a list of the papers read at the session, in addition to those already mentioned:

- 'Among the Birds in Nevada,' Harry C. Oberholser.
- 'The Geographical Distribution of the Wrens of the *bewickii* Group,' Harry C. Oberholser.
- 'The Moults of Passerine Species in the vicinity of New York City,' Jonathan Dwight, Jr.
- 'The Nocturnal Flight of Migrating Birds,' O. G. Libby.
- 'The Distribution and Relationships of *Ammodramus maritimus* and its allies,' Frank M. Chapman.

'Chadbourne on Individual Dichromatism in *Megascops asio*, with some evidence on the question,' William Palmer.

'The Prothonotary Warbler, *Protonotaria citrea*, a common summer resident of Southeastern Minnesota,' Thomas S. Roberts.

'Polygamy among Oscines,' F. E. L. Beal.

'Crow Roosts in Eastern Pennsylvania and New Jersey,' Witmer Stone.

'Some Parasites of Birds,' by title, Vernon L. Kellogg.

'Some Characteristics of Neosoptiles,' William Palmer.

'The Generic Names *Pediocetes* and *Poocetes*,' Theo. Gill.

'The Blue Honey-creepers of Tropical America,' Harry C. Oberholser.

'The Water Ouzel on Mt. Shasta,' Florence A. Merriam.

The next meeting will be held in Philadelphia, commencing November 13, 1899.

JOHN H. SAGE,

Secretary.

#### CURRENT NOTES ON ANTHROPOLOGY.

##### THE MAP OF CUAUHTLANZINCO.

UNDER the above name Mexican archaeologists have described a series of paintings about thirty-three in number, preserved in the native town bearing the appellation. They were drawn and colored some decades after the Conquest, in order to preserve the memory of that portion of it in which the town was engaged. In the present century a new copy was made, as the first canvasses were falling to pieces. Inscriptions in Nahuatl and Spanish were added, to explain the various scenes depicted by the native artists.

Professor Frederick Starr visited the hamlet in 1895 and again last January, and obtained photographs of all the pictures and a copy of the Spanish explanations. These he has published in an instructive monograph, issued from the press of the University of Chicago. It will be read with pleasure by those interested in the archaeology of Mexico ('The Mapa de Cuauhtlanzincó or Códice Campos').

## THE VARIATIONS OF THE MUSCLES IN MAN.

THE racial variations in the soft parts of the human frame is a much more difficult study than that which limits itself to the bony skeleton. For that reason anthropologists will welcome the publication of the results obtained by the late Dr. H. Chudzinski, who for twenty years occupied himself with such investigations. They are in part contained in a volume of 226 pages, edited by the eminent anatomist, Dr. L. Manouvrier, and published by the Anthropological Society of Paris. The comparisons are most complete between the white and black races, as of those, Dr. Chudzinski could, in Paris, secure good specimens. As for the 'yellow race,' in which he included a Carib, a Peruvian, a black from Pondichery and two natives of Farther India, evidently little value can be assigned its peculiarities, as based on such examples. (*Variations musculaires dans les races humaines*, Paris, Masson et Cie, 1898.)

## PASSAMAQUODDY LITERATURE.

PREVIOUSLY in these notes (SCIENCE, May 13, 1898) I have referred to Professor J. D. Prince's interesting studies in the Passamaquoddy dialect. He has supplemented those by an article in the *Annals* of the New York Academy of Sciences (Vol. XL, No. 15), giving, from pure native sources, an outline of Wabanaki history previous to the establishment of the intertribal *modus vivendi* set forth in the 'Wampum laws.' The account illustrates the primitive condition of murderous warfare which prevailed, and the efforts of the wiser heads of the hordes to put a stop to such destructive excesses.

The paper ends with a Passamaquoddy love song which is presented in the original, with an English translation, and explanatory notes of the text.

D. G. BRINTON.

UNIVERSITY OF PENNSYLVANIA.

## SCIENTIFIC NOTES AND NEWS.

WE are now able to give some further details in regard to the meeting of the American Society of Naturalists, and of the Societies holding their meetings in New York City in conjunction with it. The first meeting of the Society of Naturalists will be in the American Museum of Natural History on the evening of Wednesday, December 28th. After a welcome by the President of the Museum, Mr. Morris K. Jesup, Professor Henry F. Osborn will give a lecture on 'Collections of Fossil Mammals and their Care,' and will afterwards receive the members of the Societies at his house. The chief meeting of the Naturalists will be held on the afternoon of December 29th at Schermerhorn Hall, Columbia University. After the Societies have been welcomed by President Low a series of short papers will be read on 'Advances in Methods of Teaching' as follows:

Zoology: Professor E. G. Conklin, University of Pennsylvania.

Anatomy: Professor George S. Huntington, Columbia University.

Physiology: Professor W. T. Porter, Harvard Medical School.

Psychology: Professor Hugo Münsterberg, Harvard University.

Anthropology: Dr. Franz Boas, Columbia University.

Botany: Professor W. F. Ganong, Smith College.

The annual dinner will be held at the Hotel Savoy, and after the dinner the President of the Society, Professor Bowditch, will make an address. Visits to the Botanical and Zoological Parks have been arranged for December 30th.

THE other Societies holding scientific sessions simultaneously with the Naturalists open their meetings on Wednesday, except the Anthropologists of the American Association, who begin on Tuesday. Announcements of these meetings have been or will be sent out by the Secretaries to members, and further information can be obtained from them. The addresses of the several Secretaries are as follows:

Dr. H. C. Bumpus, Brown University, Providence, Secretary of the The American Society of Naturalists.

Dr. G. H. Parker, 6 Avon Place, Cambridge, Mass., Secretary of The American Morphological Society.

Dr. D. S. Lamb, 800 Tenth Street, N. W., Wash-

ington, D. C., Secretary of The Association of American Anatomists.

Dr. F. S. Lee, Columbia University, New York City, Secretary of The American Physiological Society.

Dr. Livingston Farrand, Columbia University, New York City, Secretary of the American Psychological Association.

Mr. W. W. Newell, Cambridge, Mass., Secretary of The American Folk-Lore Society.

Dr. W. F. Ganong, Smith College, Northampton, Mass., Secretary of the Society for Plant Morphology and Physiology.

Dr. H. M. Saville, American Museum of Natural History, New York, Secretary of Section II (Anthropology) of the American Association for the Advancement of Science.

PROFESSOR WILLIAM TRELEASE, Director of the Missouri Botanical Garden, and Mrs. Zelia Nuttall have been elected honorary members of the Sociedad Científica (Antonio Alzate), of Mexico.

M. LEVY, the mining engineer, Paris, and Professor Lindström, Director of the Natural History Museum of Stockholm, have been elected corresponding members of the Berlin Academy of Sciences.

THE Munich Academy of Sciences has elected the following members: Professor Fuchs, of Berlin (mathematics); Professor Barraix, of Lille (geology); Professor Lie, of Christiania (mathematics); Professor Hartig, of Munich (botany); Professor Pringsheim, of Munich (mathematics), and Professor Oberhammer, of Munich (geography).

PROFESSOR G. FREDERICK WRIGHT, of Oberlin College, has made plans for a trip around the world in 1900, for the purpose of studying geological phenomena. He will visit Hawaii, Japan, cross Asia, following the line of the new Siberian railroad, studying especially the Siberian glacial drift, a field as yet untouched; thence, after a study of the region around the Caspian Sea, he will return to the United States, the whole trip occupying about nine months.

PROFESSOR JAMES E. KEELER, the recently appointed Director of the Lick Observatory, was given a reception and banquet on October 15th, at San Francisco, by the members of the faculties

of the University of California. There were about sixty present. Addresses of welcome were made by the President of the University and Professor Soulé, and Professor Keeler replied.

DR. WILLIAM C. KRAUSS, of Buffalo, N. Y., has been elected President of the American Microscopical Society.

A FURTHER grant of £250 has been made from the Worts Travelling Scholars' Fund of Cambridge University to Dr. Haddon, towards defraying the expenses of the scientific expedition to the Torres Straits under his direction for the purpose of making anthropological investigations.

THE French Institute announces as the subject of the Crouzet prize (3,000 fr.) for 1901, 'The Theory of Evolution in Nature and in History.'

THE French Geographical Society held a special session on November 19th in honor of the explorer M. Gentil. M. Milne-Edwards, who presided, after congratulating M. Gentil on his remarkable explorations in the neighborhood of Lake Tchad, announced that the Society had awarded to him its large gold medal for the year 1899.

THE monument erected to Charcot, the great French neurologist, before the Salpêtrière Hospital, Paris, was unveiled on December 4th. M. Leygues, the Minister of Public Instruction, made an address.

SIR GEORGE STOKES was elected Lucasian professor of mathematics at Cambridge on October 28, 1849, and the current academical year is thus the 50th year of his tenure of the chair. The Council of the University, having regard to the acknowledged eminence of Sir George Stokes and to the rarity of such an event as a 50 years' tenure of a professorship in the University, are of opinion that some formal celebration of the completion of this period should be held towards the end of the present academic year, and that a number of distinguished men of science, and also representatives of universities and other learned bodies at home and abroad, should be invited to participate in the celebration. They have considered various dates that are suitable for the celebration, and



have come to the conclusion that June 1 and 2, 1899, will be the most convenient. The Council recommend that a sum of £400 be placed at their disposal for the celebration.

MR. RICHARD BANNISTER, late Deputy-Principal of the Government Laboratory, says the *London Times*, was presented, on November 21st, in the hall of the Civil Service Volunteers at Somerset House, with a testimonial which had been subscribed for by his colleagues and friends in the department from which he has recently retired after a service of 42 years. In making the presentation Dr. Thorpe, F.R.S., the Principal Government Chemist, after referring to Mr. Bannister's long and varied experience in the Government Laboratory, spoke of his work outside the department, with which the public were perhaps better acquainted. His administration of the Food and Drugs Act and his numerous appearances before Royal Commissions and Parliamentary Committees, as well as his selection as a juror at several of the South Kensington Exhibitions, were evidences of the value in which his vast and unrivalled experience, not only in chemistry, but in the trading and commercial interests connected with it, were held. Mr. Steele, late Chief Inspector of Excise, and others also bore witness to the value of Mr. Bannister's services both to the department and the public generally.

THE death is announced of Professor George T. Allman, F.R.S. He was born in Ireland in 1812, and was appointed professor of botany in Dublin in 1844. In 1855 he was called to Edinburgh, and was there professor of natural history till 1870. He described the hydroids collected by the Challenger Expedition, and published a number of monographs treating of the invertebrates.

WE regret also to announce the deaths of M. J. N. Raffard, a French inventor; of Herr A. Hubner, the historian, General Secretary of the Vienna Academy of Science, and of Sir George Baden-Powell, who has in many ways promoted scientific undertakings in Great Britain.

A CIVIL SERVICE examination will be held on December 15th for the position of Assistant in

Entomology, Office of Experiment Stations (Department of Agriculture). The examination will consist of the subjects mentioned below, which will be weighed as follows:

Biology and entomology	50
French or German (translation of scientific literature)	10
Editing and abstracting	10
Essay	15
Training and experience	5
Additional modern languages, or veterinary science	10
Total	100

LIEUTENANT A. P. HAYNE, an instructor in the agricultural department of the University of California, now stationed with one of the California regiments at Manila, has been detailed to conduct an official investigation into the agricultural resources of the Philippines, and to make a report of the results to Washington.

THE Secretary of State has received a cable message from United States Consul Gibbs at Tamatave, Madagascar, saying that the bubonic plague has broken out at that place.

THE Valentine Museum at Richmond, Va., was formally opened to the public on November 21st. It is a gift to Richmond by the late Mann S. Valentine, and includes, housed in his recent mansion, his valuable collection of books, oil-paintings, manuscripts and casts, supplemented by scientific collections of anthropological specimens. The will of Mr. Valentine expresses his desire that the Museum be closely associated with and an aid to the educational institutions of the State; that it publish literary and scientific papers and preserve objects of antiquity compatible with the amount of endowment of the Museum.

THE University of Michigan Museum has been enriched by a gift of the collection of musical instruments brought together by Frederick Stearns. In presenting this collection, of nearly 1,000 pieces, Mr. Stearns turned over the results of fifteen years' research and over \$25,000 expenditure. The present value of the collection is much greater than its original cost. Among other things, it illustrates the evolution of several musical instruments from primitive times down to the present.

THE New York State College of Forestry has secured its 30,000-acre demonstration area of Adirondack forest. The terms of sale are agreed on, and only a survey delays the formal turning over of the property. The tract lies in Franklin county, to the south of Saranac Lake, and partly upon the lower slope of Mt. Seward. It contains some virgin forest, some from which lumbermen have taken the choice timber, and some from which forest fires have taken all the timber. The College can, therefore, at the start demonstrate all sides of forestry, from planting bare tracts to lumbering and getting the logs to market.

THE Ludwig Institute courses of free lectures are now being given on the evenings of Mondays and Thursdays at the Philadelphia Academy of Natural Sciences. Dr. Edward J. Nolan has given two lectures on the literature of natural history. Mr. Witmer Stone and Professor Henry A. Pillsbury are at present giving courses respectively on vertebrate zoology and on the oyster and the clam. After Christmas Dr. Benjamin Sharp will give a course on comparative anatomy and physiology, Dr. Henry Skinner a course on entomology, Mr. Stewardson Brown a course on botany and Dr. Seneca Egbert a course on hygiene.

A CABLEGRAM to the New York *Evening Post* states that Mr. George Murray's deep-sea expedition, to the plans of which we recently referred, has completed its work in the North Atlantic. Its main object was to obtain further information regarding the vertical range of life in the sea, especially to test Professor Agassiz's theory that the intermediate depths of ocean are uninhabited, life being confined to the uppermost 500 fathoms and the lowest 100 fathoms. Depths of 1,370 and 1,835 fathoms were reached, samples of typical globigerina ooze being brought up from the latter. The full bearing of the results of the expedition must await many months of sorting and cataloguing of collections, but the general impression of the members of the expedition is that the Agassiz theory will not be maintained.

A SPECIAL despatch from Yeniseisk, on the river Yenissi, in eastern Siberia, announces the arrival at the mouth of the river of an expedition that

had gone in search of Herr Andrée, the aeronaut. The expedition was wrecked while crossing from the delta of the river Lena to the river Olenek, which flows into the Arctic Ocean southwest of Bennett and Delong Island, but managed to reach an uninhabited island about 120 miles from the mouth of the Olenek. The party was ice-bound for seventeen days before it was succored.

M. THIBEAUT, Chargé d'Affaires of France, has notified Secretary Hay that the French government is about to adopt precautionary measures against the introduction of this country of the San José scale, and that decrees will be issued prohibiting the importation of trees, shrubs and plants from the United States and requiring an inspection of all fruits, fresh and dried, at the point of landing in France.

#### UNIVERSITY AND EDUCATIONAL NEWS.

THE Lawrence Scientific School, Harvard University, has received \$10,000 from Mr. J. H. Jennings, of the class of '77, for the establishment of a scholarship. The scholarship for the current year goes to Mr. T. F. Sanborn.

JAMES STILLMAN, of New York, has given \$50,000 to Harvard College to cover the cost of land and buildings for a projected Harvard Infirmary, which will bear the name of the donor. In addition, Mr. Stillman will contribute \$2,500 annually for four years.

THE will of the late Charles P. Wilder, of Wellesley Hills, bequeathes \$102,000 to Mount Holyoke College, and the trustees of Wellesley College announce a gift of \$50,000 made by Mr. Wilder before his death. No conditions are attached to the gift.

THE Catholic University of Washington has received the information that by the will of Daniel T. Leahy, of Brooklyn, it receives \$10,000. No instructions accompany the bequest.

WE have been able to record recently two important gifts to the University of Cincinnati, including the gift of a library building by Mr. Asa Van Wormer. The University has now been presented by Mr. William A. Proctor with the library of Mr. Robert Clarke, containing 6,704 volumes valued at over \$50,000.

A FUND of \$100,000 is being raised by the trustees and friends of Oberlin, the income from which is to be applied to the reduction of the term bills of needy students. About one-tenth of this amount has already been collected.

THE Commission appointed under the University of London Act, 1898, consisting of Lord Davey (Chairman), the Bishop of London, Sir William Roberts, Sir Owen Roberts, Professor Jebb, Professor Michael Foster and Mr. E. H. Busk, with Mr. Bailey Saunders as Secretary, has commenced its sittings.

THE Montreal correspondent of the *New York Evening Post* states that according to present arrangements the formal opening of the new chemistry and mining building at McGill University will take place on December 20th. There is a possibility, however, that an earlier date may be selected in order to meet the convenience of Lord Strathcona, who wishes to be in Scotland for Christmas day. The Governor-General and the Countess of Minto will be present. The authorities of McGill University have been notified of the loss of between \$3,000 and \$4,000 worth of chemical apparatus intended for the new chemical laboratories at the University. The goods were shipped by the ill fated *Westmeath*, which was lost at sea a short time ago.

DR. JOHN HENRY BARROWS has been elected to the Presidency of Oberlin College. This action was taken by the trustees of Oberlin on Tuesday, November 29th, and the vote was unanimous. Dr. Barrows is widely known as the pastor of the First Presbyterian Church of Chicago, and as the one who pushed the Parliament of Religions at the World's Fair through to its successful end. During the last two years he has been lecturing in Calcutta, India, on the Haskell lectureship of the University of Chicago. Definite word has not yet been received as to his acceptance, but the trustees had assurance that he would accept, before the action was taken.

THE Normal College, New York City, has adopted courses of study by which the students may receive academic degrees. The members of the faculties concerned with the sciences are

as follows: Professor Joseph A. Gillette, analytical geometry; Professor Burgess, biology and geology; Emily I. Conant, Ph.D., psychology, and Isabel Camp, Ph.D., pedagogics.

THE Council of King's College, London, have appointed Mr. Ernest Wilson, M.I.E.E., professor of electrical engineering in succession to the late Professor Hopkinson.

#### DISCUSSION AND CORRESPONDENCE.

##### A SELF-READJUSTING 'COHERER.'

TO THE EDITOR OF SCIENCE: Van Gulik has shown [*Wied. Ann.*, No. 9.] that, when an oscillating electric discharge takes place across a minute gap between the ends of two fine platinum wires, the ends of the wires are drawn together and remain clinging together after the discharge has ceased.

Upon repeating some of his experiments in a modified form, I am led to the conclusion that such adherence does not always result if the gap be between dissimilar metals.

Advantage may be taken of this to construct a self-readjusting 'coherer.' If a Branly tube be filled with a mixture of tin and aluminium filings it acts normally in so far that, when subjected to the influence of electric waves, its resistance is greatly diminished. When the radiation has ceased, however, its resistance again rises, unaided by any tapping back. A similar result obtains, though the reaction is usually more sluggish, with a pile of alternate disks of aluminium and tin foil.

A. E. LAWRENCE.

COLUMBIA UNIVERSITY,  
November 19, 1898.

##### ADDITIONAL NOTES ON AN APPLE CANKER.

FROM observations made since the publication of the article 'An Apple Canker' in SCIENCE for October 28, 1898, it seems highly probable that *Sphaeropsis malorum*, Peck, is not only parasitic on the wood of the apple, but on the wood of pear and quince as well. It would, therefore, seem that a further note on the subject will not be out of place.

In the spring of 1898 specimens of blighted apple twigs were received. It was not determined at the time what was the cause of the



blight, but later the surface of the bark was found to be thickly dotted with the pycnidia of *Sphaeropsis*.

On visiting the orchard, which comprised about five acres, it was found that the blight had been quite noticeable in 1897. In all cases noticed when once attacked the entire growth of the season had been killed, and in a few instances the disease had extended into the previous season's growth. The dead twigs varied from a few inches to a foot or more in length. But few twigs of the current season's growth were found to be attacked. The growth of the disease on the twigs is determinate, a definite constriction usually separating the dead from the living wood. A few miniature canker spots were found on the smaller limbs, but none were noticed on the larger limbs, as is usually the case. The trees were generally in good condition, and the black rot of the fruit was not specially abundant.

Some pear trees in a door yard about twenty-five rods distant from the orchard were found to be dying. The top of one tree had been entirely removed, while the other trees were a half or two-thirds dead. These trees were also found to be attacked by a *Sphaeropsis*, the pycnidia being very abundant on the dead bark. The spread of the disease was from the top downward, a distinct boundary separating the dead from the living wood. A few black shrivelled pears were still attached to some of the dead branches.

A *Sphaeropsis* was also found on the twigs of some quince trees that grew by the side of the pear trees. The injury in this case was slight.

At a later date a canker was found on some quince trees in the Experiment Station orchard. Here the appearance of the cankers and their effect was much the same as on apple trees. Pycnidia of a *Sphaeropsis* were abundant where the fungus was in active growth. The disease was also found to be abundant in a large quince orchard, in the vicinity of Geneva, where it has done a considerable amount of damage.

Cultures of the *Sphaeropsis* were made from the twigs of the three different host plants, and fruits of the apple, pear and quince were inoculated with material from each of the three series of cultures. *Sphaeropsis malarum*, Peck,

was produced in each case, while check fruits punctured but not inoculated, remained sound. GENEVA, N. Y. W. PADDOCK.

#### SCIENTIFIC LITERATURE.

*Lehrbuch der anorganischen Chemie.* Von PROFESSOR DR. H. ERDMANN in Halle, mit 276 Abbildungen und vier farbigen Tafeln. Braunschweig, Vieweg. 1898. Pp. 756.

Professor Erdmann has taken the Gorup-Besanez text-book (1876) as a foundation, but has so changed, improved and modernized the work that it may fairly be considered entirely new.

The printing and illustrations are admirable; particular attention is called to the beautiful colored plates of the spectra of various elements, including argon and helium, which show a wonderful delicacy of tone.

In an introduction of eighty pages the author discusses chemical theory, temperature, gases, atomic and molecular weights, and similar topics. The remainder of the book is chiefly descriptive, yet modern theory is introduced when needed. The striking features of the book are its thoroughness, its completeness, and the particular attention given to technical methods, preparation and experiment. As to thoroughness and completeness the reviewer has not succeeded in detecting the omission of a single fact of importance in inorganic chemistry, which could suitably find place in a book of the size and which was mentioned in chemical journals before 1898.

As to technical methods a few examples must suffice. It is generally known that much or most of the chlorine now made is by electrolysis of aqueous potassium chloride; but that chlorine is technically obtained as by-product in the electrolysis of zinc from zinc chloride, magnesium from carnallite and sodium from salt, will be new to many, as will be the manufacture of hydrochloric acid on a large scale from magnesium chloride and steam:  $MgCl_2 + H_2O = MgO + 2HCl$ . If we turn to magnesium chloride we learn that, in addition to its use for hydrochloric acid and (as carnallite) for magnesium, 15,000-20,000 tons are yearly exported from Stassfurt to be used in cotton factories instead of oil, as concentrated magnesium

chloride solutions are oily to the touch and serve to make cotton thread pliable.

The reviewer does not wish to give the idea that this work is chiefly technical; it is not; it is a scientific text-book of the highest rank; but the author notices briefly many important modern uses of common substances which are not known to the average teacher of chemistry, but should be known to the average advanced student. We find descriptions and drawings of apparatus for making argon, helium, liquid air (Linde), liquid oxygen (both Pietet and Cailletet) and fluorine (Moissan). Each chapter has an appendix on 'Technique and Experiments,' in which the best laboratory and lecture-room experiments are described with drawings; the author's previous books on inorganic and organic preparations are guaranteed that this part of the work is excellent.

One feature in the book calls for adverse criticism. No mention is made of relations between the atomic weights and properties of elements till the close of the book, where one page is given to relations like those existing between the atomic weights of the halogens, and two pages to the periodic system. No mention is made of the periodic law as a generally recognized law. The author says: "Mendelejeff has definitely stated that the properties of the elements are periodic functions of their atomic weights;" and this is the only reference to such a law. This seems to the reviewer a serious blemish in a book otherwise so excellent. It may be that the author feels towards the periodic law as the Irishman felt towards government, but at least a fuller discussion of the subject is desirable. Surely the recognition given of late years to the 'family' relations of the elements, and the use of the periodic system throughout text-books, have been a great help to students. One misses this in the author's treatment of the halogens, for example; yet the single halogens and their compounds are so well discussed, and the chapter on iodine is such a masterpiece, full of information, some of which will be new to most college professors, that it becomes hard to criticize anything so good.

This work is an excellent text-book for advanced college students; it is an excellent book of reference for the lecturer and high-school

teacher, and it should be carefully read by college professors.

E. R.

*Lecture Notes on the Theory of Electrical Measurements.* By WILLIAM A. ANTHONY. New York, John Wiley & Sons. Pp. 90.

This little volume is designed to furnish the student with the broad outlines of the subject treated, and to thus assist him in getting possession of the subject as more elaborately presented in a series of lectures. The fundamental equations upon which electrical measurements are based are given, and the physical conditions to which they apply are stated with clearness. The book opens with a short chapter on C.G.S. units. Then follow chapters on the magnetic field, current, potential and electromotive force and resistance, with a statement of Ohm's law. The international electrical units are then treated. The general plan of measuring resistance, current and potential is explained, the instruments used being represented in diagram. The second branch of the subject closes with a treatment of the methods of calibrating amperemeters, voltmeters, resistance sets and bridge wires. The remaining portion of the work, comprising sixteen pages, is devoted to the effects of the current in heating, glow and arc lighting, electrolysis and electro-magnetic induction. The electro-magnetic circuit is also discussed. The book is provided with an index and table of contents.

F. E. N.

*The Mechanical Composition of Wind Deposits.*

By JOHAN AUGUST UDDEN. (Augustana Library Publications, No. 1.) Rock Island, Illinois. 1898. Large 8vo. Pp. 69.

Professor Udden has for some years been engaged in researches concerning the mechanical composition of the loess skirting Mississippi River, and has been led to a comparative study of the composition of other deposits, especially of eolic origin, and also to a highly-refined investigation of atmospheric dust; and his principal results, with many of the details, are incorporated in this memoir. For convenience, he classifies wind-deposits in eleven grades, from coarse gravel (8-4 millimeters in diameter) to very fine dust ( $\frac{1}{125}$ - $\frac{1}{250}$  millimeters in diameter), and the examination was so conducted as

to ascertain the magnitude of the particles and the relative proportions of the different grades in terms of this scale. "Down to the particles measuring one-eighth of a millimeter all the separations were made by sieves, and below this the per cent of the weight of each grade was determined by microscopic measurements and by calculation from the number of grains counted in each grade" (page 6). Acknowledgment is made to Professor Milton Whitney for information concerning the mechanical analyses in the United States Department of Agriculture. The deposits examined include drifting sand, both rolled and dune, from Illinois, Indiana, Kansas, Nebraska, North Dakota and Massachusetts; and lee sand from Illinois, Kansas and North Dakota. In addition, special attention was given to atmospheric dust, formed and carried under various conditions, which was collected by ingenious devices. In the final pages the author discusses the principles of what may be called eolation, *i. e.*, eolic erosion (the deflation of Walther) and eolic deposition, and he refers to the bearing of the researches on the problem of the loess, though wisely withholds final judgment concerning the solution of the problem. The memoir carries inherent evidence of patient and painstaking labor; and, since the labor extended into a little-wrought but important field, it must take rank as a notable contribution to geology.

W J M.

#### SCIENTIFIC JOURNALS.

THE *American Journal of Science* for November contains the following articles:

'Another Episode in the History of Niagara Falls:' By J. W. Spencer. 'Apparatus for Measuring very High Pressures:' By A. deF. Palmer, Jr. 'Application of Iodine in the Analysis of Alkalies and Acids:' By C. F. Walker and David H. M. Gillespie. 'Associated Minerals of Rhodolite:' By W. E. Hinden and J. H. Pratt. 'Revision of the Moraines of Minnesota:' By J. E. Todd. 'Preliminary Report on some new marine Tertiary horizons discovered by Mr. J. B. Hatcher near Punta Arenas, Magellanes, Chile:' By A. E. Ortmann. 'Comparative Value of Different Kinds of Fossils in Determining Geological Age:' By O. C. Marsh. 'Families of Sauropodus I inosauria:' By O. C. Marsh. 'Biotitite-guaitite Dike from Manchester by the Sea, Essex

County, Mass.:' By A. S. Eakle. 'Descriptions of new American Actinians with critical notes on other species, I.:' By A. E. Verrill.

THE *Journal of Comparative Neurology*, published quarterly at Granville, Ohio, and edited by President C. L. Herrick, Dr. O. S. Strong and Dr. C. Judson Herrick, has added to its collaborators Professor C. F. Hodge, of Clark University (Neurocytology, especially functional changes in nerve cells); Dr. G. H. Parker, Harvard University (The sense organs and nervous system of the invertebrates), and Professor A. D. Morrill, Hamilton College (The sense-organs of the vertebrates).

THE *Educational Review* for November opens with an article on the 'Status of the American Professor,' by 'One of Them.' The author urges that the American professor, with the exception of those in several of our larger universities, lacks a proper income, proper authority and proper leisure. Especial attention is called to the unfortunate fact that a college instructor can often only secure the advancement that is his due by securing a call from another university. The author might have added that the conditions are peculiarly bad in America, where an offer from a university is usually given privately and sometimes confidentially. In Germany a vacant position is usually offered to the man who is thought to be the best and who at the time holds a position that is considered less desirable, without regard to whether he is likely to accept or not. The German professors and docents have thus in their own subjects a rank depending on their reputation and efficiency, which is tolerably well known to the authorities of all the universities.

#### SOCIETIES AND ACADEMIES.

SECTION OF GEOLOGY AND MINERALOGY OF THE  
NEW YORK ACADEMY OF SCIENCES,

OCTOBER 17, 1898.

THE first paper, by Professor J. F. Kemp, on the Minerals of the Copper Mines at Ducktown, Tenn., gave a brief history of the mines and described some of the processes employed in treating the ores, and the character of the rocks and associated minerals. The paper was illustrated with an extended series of lantern views



of the mines and the works, and with a suite of specimens. Professor Kemp referred particularly to the extremely interesting crystals of almandite garnet which he showed, in which the faces of the hexactahedron are strikingly developed, giving 48-sided forms, sometimes with small faces of the rhombic dodecahedron in addition. Zaisite also occurs in fine terminated crystals, and limonite of remarkable iridescence.

The second paper was by Dr. Arthur Hollick—Notes on the Glacial Phenomena of Staten Island—and embodied the general results of several years of study and exploration by himself and others. He outlined the topography of the island and the distribution of drift material upon it, and described the transported contents of the drift with relation to their sources. Most of the drift material is made up of the triassic sandstone and shale of the adjacent mainland, ground up by the ice sheet, but the boulders are largely brought from afar. They comprise material from all the fossiliferous beds of central New York, from the Potsdam to the Hamilton; but there is a great preponderance of Lower Helderberg and Schoharie grit. The fossils are in many cases finely preserved, have been collected in large quantities, and very carefully studied and determined. The question as to the route by which they have come, over the hilly and almost mountainous regions lying between their source and their resting place, is one of much interest.

The next paper was by Mr. Francis C. Nicholas—on the Sedimentary Formations of Northern South America—and dealt with a large area of little-explored country between the Caribbean coast and the northern Andes. It was illustrated by a most extensive and carefully labeled series of rocks, ores and minerals from many localities and horizons, to which it was impossible to do justice within the limits of the evening. Among many interesting points described and illustrated with specimens was the agency of the sun's heat as a rock-disintegrator, the changes of day and night temperature in high regions in the tropics producing a fracturing of the superficial portions of exposed rocks comparable in result to the action of frost in higher latitudes.

The last paper was by Mr. Geo. F. Kunz, upon a Meteoric Stone that fell at Andover, Maine, on August 5th last, with exhibition of the stone, or rather about half of it. The fall took place early in the morning of a cloudy and threatening day; so that the sound made by the meteor, which was heard for many miles around, was generally supposed to be thunder. A dark cloudy trail, like a dense smoke, followed and marked the path of the body through the air. Its course was from the north, southward, and in coming down it tore its way through a group of large trees, struck a heavy stone in a wall near the ground, and buried itself in the earth. Here it was found two days later, by that time entirely cooled. The specimen is a typical stony meteorite, with a thin black crust on the outside, and of a bright pale gray on the broken surface, with very little iron. It weighs about 7 lbs., and its description will appear later.

#### NEW BOOKS.

- Instinct and Reason.* HENRY RUTGERS MARSHALL. New York and London, The Macmillan Company. 1898. Pp. xiii + 574. \$3.50.
- Truth and Error.* J. W. POWELL. Chicago, The Open Court Publishing Company. 1898. Pp. 428. \$1.75.
- Symbolæ Antillanæ seu fundamenta Floræ Indæ Occidentalis.* IGNATIUS URBAN. Berlin, Borntraeger. 1898. Vol. I. Part I. Pp. 192. M. 10. 80 Pf.
- Deutscher Botaniker Kalender für 1899.* P. SYDOW. Berlin, Borntraeger. 1898. Pp. 198. M. 3.
- Congrès national d'hygiène et de climatologie médicale de la Belgique et du Congo.* Bruxelles, Hayez. 1898. 2d part. Pp. 247-890.
- Traité élémentaire de mécanique chimique fondée sur la thermodynamique.* P. DUHEM. Paris, A. Hermann. 1898. Vol. III. Pp. 380. 10 fr.
- The Principles of Biology.* HERBERT SPENCER. New York, D. Appleton & Co. 1898. Part I. Revised and Enlarged. Pp. xii + 706. \$2.00.

# SCIENCE

EDITORIAL COMMITTEE: S. NEWCOMB, Mathematics; R. S. WOODWARD, Mechanics; E. C. PICKERING, Astronomy; T. C. MENDENHALL, Physics; R. H. THURSTON, Engineering; IRA REMSEN, Chemistry; J. LE CONTE, Geology; W. M. DAVIS, Physiography; O. C. MARSH, Paleontology; W. K. BROOKS, C. HART MERRIAM, Zoology; S. H. SCUDDER, Entomology; C. E. BESSEY, N. L. BRITTON, Botany; HENRY F. OSBORN, General Biology; C. S. MINOT, Embryology, Histology; H. P. BOWDITCH, Physiology; J. S. BILLINGS, Hygiene; J. MCKEEN CATTELL, Psychology; DANIEL G. BRINTON, J. W. POWELL, Anthropology.

FRIDAY, DECEMBER 16, 1898.

THE GENERAL CONFERENCE OF THE INTERNATIONAL GEODETIC ASSOCIATION  
AT STUTTGART, OCTOBER 3-12,  
1898.\*

## CONTENTS:

<i>The General Conference of the International Geodetic Association at Stuttgart, October 3-12, 1898:</i> E. D. PRESTON.....	841
<i>The Annual Report of the Secretary of Agriculture:</i> A. C. TRUE.....	847
<i>The Breeding of Animals at Woods Holl during the Months of June, July and August:</i> PROFESSOR H. C. BUMPUS.....	850
<i>An Ampere Balance:</i> PROFESSOR W. E. AYRTON, PROFESSOR J. VIRIAMU JONES.....	858
<i>Notes on Physics:—</i> <i>Electrical Vibrations; Manometric Flames; Etherion:</i> W. S. F.....	859
<i>Zoological Notes:—</i> <i>The Brain of the Chimpanzee; Fresh-water Pearls of the United States; The Washington Meeting of the American Ornithologists' Union:</i> F. A. L.....	860
<i>Current Notes on Anthropology:—</i> <i>Origin of Neolithic Art in France; Palaeolithic Stations in Russia; The Stigmata of Degeneration:</i> PROFESSOR D. G. BRINTON.....	862
<i>Scientific Notes and News:—</i> <i>The 'Humane' Society; The Seventh International Geographical Congress; State Ownership of the Telegraph and Telephone; General.....</i>	863
<i>University and Educational News.....</i>	871
<i>Discussion and Correspondence:—</i> <i>Zoological Bibliography and Publication:</i> F. A. BATHEL. <i>Men of Science and the Humane Society:</i> H. C. MERCER.....	872
<i>Scientific Literature:—</i> <i>Ward's Outlines of Sociology:</i> GUSTAVO TOSTI. <i>Instincts and Habits of the Solitary Wasps:</i> PROFESSOR T. D. A. COCKERELL. <i>Four-footed Americans and their Kin:</i> W. H. OSGOOD. <i>Qualitative Chemical Analysis:</i> PROFESSOR EDWARD RENOUF. <i>Dana's Text-book of Mineralogy:</i> A. J. M.....	874
<i>Scientific Journals.....</i>	879
<i>Societies and Academies:—</i> <i>Section of Biology of the New York Academy of Sciences:</i> DR. GARY N. CALKINS. <i>The Philosophical Society of Washington:</i> E. D. PRESTON.....	879

THE International Geodetic Association is an organization for the measurement of the earth. Conferences are held every few years to consider projects, formulate methods and direct the execution of work by which the aforesaid object may be attained. Although the name as used in English does not necessarily imply the determination of the earth's size and shape, this is, nevertheless, the governing idea, and the Association follows loyally the lines marked out by the society of which it is the legitimate offspring, the German Gradmessung of 60 years ago. Now that the Association is firmly established on a permanent and international basis, it is worth while to seek the origin and trace its interesting course of development. In 1829 the Russian government expressed a desire to connect their triangulation with that of Prussia. Thus stimulated, the German work was given greater expansion, and in 1838 the work of Bessel and Baeyer, 'Gradmessung in Ostpreussen,' appeared. This developed into the 'Kustenvermessung,' and the work was continued under that name. In 1861 Baeyer sounded the keynote of the scientific spirit of the age when he proposed co-

MSS. intended for publication and books, etc., intended for review should be sent to the responsible editor, Professor J. McKeen Cattell, Garrison-on-Hudson, N. Y.

\* Published by permission of the Superintendent of the Coast and Geodetic Survey.

operation with other nations and laid the foundation for what was called the middle European 'Gradmessung.' These limits held until 1867 when the word 'middle' was dropped and the Association was enlarged to comprise representatives from all Europe. The extension seemed for a time to satisfy the energy everywhere manifest, but the fact soon became apparent that the work fell short of its full usefulness in that its bounds of activity were still too restricted. Perhaps the gigantic strides made by America and Australia in mental and material development had something to do with the change. At any rate, in 1886, the name was again changed; this time from the European 'Gradmessung' to the international 'Erdmessung.' A convention was drawn up for ten years. The powers of the League were considerably enlarged, old fetters were broken, and for the first time the Association reached its highest plane of usefulness and began to direct a homogeneous plan for the measurement of the earth.

The twelfth general conference was held at Stuttgart from the 3d to the 12th of October, 1898. Fifteen countries of the nineteen composing the Association were represented. Of the thirty-seven delegates present, fifteen came from Germany, five from France, three from Italy, two from Switzerland, two from Japan, and one each from Belgium, England, The Netherlands, Austria-Hungary, Russia, Sweden, Spain, Mexico and the United States. Each government has the privilege of sending as many delegates as it pleases, but in voting on questions coming before the conference for action but one ballot is allowed to each country. Besides the delegates, eighteen invited guests appeared, making a total of fifty-five persons present at the meetings. By far the greater part of the time was naturally taken up in reading the regular reports by the delegates on the geodetic

work accomplished in their respective countries since the last general conference. Of special interest was the contribution by Professor Helmert on the activity of the Central Bureau of the Association at Potsdam. The following work was described:

I. The systematic deviations of the plumb line in connection with the European arc on the  $52^{\circ}$  of north latitude.

II. The international latitude service.

III. Absolute determinations of gravity.

Without going into details at this stage of our narrative, we may note in passing one or two points brought out. The connection between Switzerland and Italy is now satisfactorily made. It rests, however, on a single triangle, due to the fact that one of the points composing the quadrilateral proposed was not occupied identically by the two surveys.

The international latitude service will be inaugurated during the summer of 1899 at four stations under the direct control and at the expense of the Association. Observations at two additional stations will be undertaken, for which the Central Bureau will supply only a part of the funds necessary. Although the mathematical conditions are not essentially changed by the introduction of Cincinnati and Tschardjui, there is great advantage from the fact that any systematic errors in the regular stations will be more readily discovered. It is a fortunate coincidence that the observatory at Cincinnati happens to be precisely on the parallel of latitude chosen for this work, and it is, moreover, a matter for congratulation that Russia is ready and willing to aid in the undertaking, to the extent of establishing and superintending the station at Tschardjui.

The report also stated that in the absolute gravity work measurement of the length of the pendulum, the most difficult operation in the whole problem, can be effected both in a horizontal and vertical position.



The knife-edges can be illuminated in any direction by means of movable mirrors, and the field of view is kept 'at the same time uniformly lighted. Experiments with an electric magnet have shown that the earth's magnetic force only exercises a retarding influence on the swinging, without having any effect on the resulting length of the mathematical seconds pendulum. The possible slight movement of the agate plate, as well as the slip of the knives, is observed by a specially designed apparatus.

It is worthy of mention in this connection that up to the present time nearly 1,400 gravity stations have been occupied, of which 1,228 are different. Austria heads the list with 698, Germany follows with 162, and the United States comes next with 88. The greater part of the remainder falls to Denmark, Russia, Switzerland, France and Italy. About fifteen different nationalities are represented in this work. The latest results from pendulum observations are with reference to changes of the force of gravity with elevation, and the derivation of a new formula for the length of the seconds pendulum at the sea-level. From a discussion of over 500 stations the conclusion is reached that what is usually known as continental attraction amounts practically to nothing, and that in general the change of the force of gravity at any point on the earth's surface depends purely and simply on the Newtonian law of the inverse square of the distance. The introduction of a spherical function of the third order in the formula for  $L$ , alluded to above, foreshadows the determination of a different curvature for the northern and southern hemispheres of the earth; yet the coefficient appears so small that the inequality cannot as yet be safely predicted. The compression given is  $1/297$  and the equatorial value of the force of gravity is about  $1/13,000$  greater than that now accepted. The investigation of the relation between disturb-

ances in the force of gravity and deviations of the plumb line is one of the most interesting problems of the near future.

The reports read by the different delegates need not be taken up here. Although full of interest to the geodesist and astronomer, they are too voluminous to be analyzed or discussed in the short space at our disposal. They will, however, be published in full, and will appear in the Proceedings of the conference, where they may be consulted and studied.

Three matters of universal interest were brought before the Association, and suitable action was had thereon. These were: I. 'The determination of the figure of the earth by the measurement of arcs and the determination of the force of gravity.' II. 'The remeasurement of the Peruvian arc.' III. 'The redetermination of the difference of longitude between Paris and Greenwich.' The first two subjects were introduced as resolutions by the United States delegate, and brought out interesting discussions. The first was proposed for the sake of directing the attention of the Association more specifically to the prime object of its existence. No one doubts the utility or necessity of a complete study of the law governing the changes of latitude, but its ultimate bearing is rather one of astronomy than geodesy. The funds of the Association are now being devoted largely to the latitude question, and the time seemed fitting to suggest work more directly in the line of its avowed purpose—the measurement of the earth. The object of the resolution was, therefore, in the nature of a recall to the original conception of its being, and bespoke in the interest of pure geodesy an application of its resources to a realization of the idea of its founders.

The remeasurement of the Peruvian arc now appears to be assured. It may be worth while just here to recall the essential features of this work. One hundred and

sixty years ago, when it was a disputed question whether the polar or equatorial diameter of the earth was the longer, the French Academy decided to make one supreme effort to settle the point. To this end, two arcs were measured: one on the equator (now known as the Peruvian arc, although it is really in Ecuador); and the other in Lapland, as near the pole as possible. These two arcs, confessedly inaccurate in the light of modern geodesy, have been employed continually in the determination of the earth's figure. Situated as they are, near the extremities of the quadrant, their influence is great on the shape deduced, so that one of the pressing needs of the day in the measurement of the earth is a redetermination of their lengths. France having made the first measure, by common consent, this country should be given the first chance to repeat the equatorial work. At the conference in Paris in 1889 the matter was brought up, but was left to be disposed of by France. Efforts were made to accomplish the task, the officers were in part designated, and arrangements for cooperation by the government of Ecuador were completed. At this juncture the revolution broke out in Ecuador and the matter came to an untimely end. It is now proposed to make a reconnaissance during the summer of 1899, report the results thereof to the Paris conference of 1900, and then decide definitely on the plans of final measurement. It is universally conceded that France should be given the first chance to act, not alone because the first measure was made by her, but also because the conference of 1889 relinquished in her interest further consideration of the subject.

The Russians and Swedes, in a quiet sort of way, are measuring an arc between the parallels of latitude  $77\frac{1}{2}^{\circ}$  and  $81\frac{1}{2}^{\circ}$  in Spitzbergen. The triangulation will require two summers and part of one winter, and will cost 100,000 Kronen (\$27,500), exclusive of

cost of vessels furnished by the governments. The field work will be finished in 1900 and the computations two years later. Fifty stations will be occupied. The sides range in length from ten to one hundred and thirty kilometers, and the bases, of which there will be only two, are to be measured with Jaederin's steel tape line, 20 meters long.

The difference of longitude between Paris and Greenwich comes up again for investigation. This question has been a sort of thorn in the side of European geodesy for ten years. In 1872 the United States Coast Survey made a determination, in order to have a check on the telegraphic longitude of our trigonometric points as determined independently from Paris and Greenwich. This was followed in 1888 by two separate determinations, one on the part of England, the other on the part of France. The results differed by more than two-tenths of a second. Our own result falls between them, and it is a matter of congratulation to all Americans that the best determination to the present day of this important quantity is the work done by the United States Coast Survey, while incidentally checking its own longitude determinations. Nothing was done to improve the agreement until 1892, when the work was repeated, both by the French and English, only to yield results practically identical with those previously obtained, so the unfortunate discrepancy still remains, and the five direct determinations already made leave the work in an unsatisfactory condition. Six indirect results may be had from combinations of general European work, through Brest, Vienna, Berlin, Bonn and Leiden, the mean of which gives the same result as the mean of the direct determinations. Nothing seems to remain, therefore, but to study the conditions of the work of 1888 and 1892, and reconcile, if possible, the outstanding difference. The

matter has been referred by the International Geodetic Association to the directors of the two observatories, and a definite result will, doubtless, soon be made known.

The variation of the latitude seems to be at present an absorbing question before the Association, and there results from action taken at the Stuttgart meeting the following status :

Six stations will be established during the summer of 1899 on the parallel of latitude  $39^{\circ} 8'$ . These will be distributed in longitude as follows: one each in Japan, Turkestan and Italy, and three in the United States. The American ones will be located at Gaithersburg, Md.; Cincinnati, O., and Ukiah, Cal. This gives a preponderance of weight to the determination of the coordinate  $Y$  ( $X$  passing through Greenwich), but a station in Portugal, which may possibly be secured later, would essentially increase the accuracy of  $X$ . Tschardjui, in Russia, and Ukiah, in California, are nearly opposite, and Mizusawa, in Japan, is in the only remaining unoccupied quadrant. The scheme proposed is, therefore, a favorable one for the study of the motion of the pole. No one knows as yet how long it will be desirable to continue the observations. The period now provided for is five years, but it is proposed to buy the land upon which the observatories will be located, or lease it for one hundred years. It is evident that at least twenty-one years would be desirable, because during the seven years of observations already made the pole has returned nearly to its mean position, and three of these cycles should be completed before any definite idea can be had as to its mean path. The cost of the entire work will be about \$10,000 annually. The visual method is to be followed regularly without, however, excluding the possibility of employing later the photographic one, which has already given excellent results. Twelve groups of stars, each comprising eight pairs,

will be selected. Six pairs in each group are destined for the latitude determinations proper, while the two remaining pairs, having great zenith distances (about  $60^{\circ}$ ), will, it is hoped, throw light on the question of refraction. The observing period for each night is four hours, and will vary from 7 p. m. to 3 a. m., depending on the situation of the group. The instrumental outfit will consist of a zenith telescope and astronomical clock for each station, except that of Japan. Here a chronometer will be substituted for the clock, on account of the frequency of earthquakes.

Although the object of the general conference was scientific discussion, a faithful historian cannot ignore the social and humanitarian side of the function. From our entrance into the beautiful capital of Wurtemberg until the time of our departure we were the recipients of the most cordial hospitality. The first session was devoted to addresses of welcome on the part of the government officials, and replies thereto by the officers of the Association. Cards of admission to the museums and public buildings were furnished, excursions to the fine old castles of the suburbs were given (always including a sumptuous lunch during the day at the expense of the government), and a final gala banquet marked the close of the convention. The official means of communication before the conference was either French or German. English, Spanish and Italian were sometimes heard during recess, but not during debate. The Japanese, Russians and Swedes spoke German; the Italians and Spanish, French; the Swiss, both. One delegate, in a moment of absent-mindedness, voted in his native tongue. The novelty of the proceeding seemed attractive, and forthwith each representative did likewise. This gave increased momentary interest to the balloting, which culminated in great hilarity when, the President, a distinguished Frenchman,



who had never been known to use anything but his native tongue at the meetings, responded 'Ja.'

Before closing the present paper, attention should be called to a few points of interest noted during the trip to Stuttgart and return. A flying visit was made to the Royal Observatory at Berlin, the Reichsanstalt at Charlottenburg, and the Geodetic Institute at Potsdam. At Paris the offices of the geographic service and the International Bureau of Weights and Measures were examined, and part of one day was devoted to the English Ordnance Survey at Southampton.

An interesting object at the Berlin observatory is the instrument with which Küstner discovered the variation of latitude. Not alone because of the splendid result achieved, but on account of the conditions under which the work was done. It is mounted on a pier more than twenty feet above ground, on a subsoil of sand, in the middle of a city, with bad atmospheric conditions and about one hundred feet from the public thoroughfares. In spite of these adverse circumstances a new fact was added to science, which had baffled the efforts of larger telescopes under immeasurably better conditions. There is much encouragement in this to investigators with scanty means at their disposal.

At the Aichungs-Kommission a balance was shown which easily determines the weight of a kilogram with an error of  $1/200$  of a milligram, being  $1/200,000,000$  part of the quantity sought. They have also a complete series of weights in quartz from  $1/2$  gram to one kilogram, and thermometers giving the temperature by estimation to  $1/1000$  of a degree Centigrade.

At Charlottenburg the most striking feature was the extension and perfection of the organization. Nine buildings in all, of which the two larger are devoted, one to theory and the other to practice, have cost,

together with the running expenses since 1887, 3,000,000 Marks. The annual outlay is at present about \$90,000.

The Geodetic Institute at Potsdam has been much less expensive, and presents many admirable points of arrangement and administration. Among the details may be cited: the clock room, always maintained at a temperature between  $20^{\circ}$  and  $21^{\circ}$  Centigrade; the pendulum room, artificially heated on all sides, including the floor; a pillar over fifty feet high, and correspondingly thick, with meridian marks several miles away, to study changes in azimuth and the movement of the earth's crust; and finally a small photographic instrument, by means of which the occupation of a station only requires 8 minutes, and gives a determination of the geographical position in latitude within two seconds of arc. The subsoil, as at Berlin, is nothing but sand.

At Sevres, near Paris, several interesting instruments were seen, among which may be especially mentioned that designed for the comparison of the metre with the wavelength of light following Michelson's method, and the apparatus for the determination of coefficients of expansion according to the method of Fizeau. Some recent experiments have been made on a composition containing 36% nickel and 64% steel. It appears that the expansion from heat is thus reduced to about  $1/50$  of what we should expect from the individual components. This discovery will simplify enormously the solution of problems where the temperature question has thus far been the great difficulty. It will, for example, be a comparatively easy matter to make pendulum clocks run with a daily correction of about  $1/10$  of a second per day under varying temperature conditions.

At the office of the geographic service of the army a noteworthy feature was the publication of charts. Six presses, each

capable of turning out six hundred maps per hour, are continually at work. Each year there are printed and distributed 1,200,000 maps, about as many as the Coast and Geodetic Survey has published since it came into existence. At Southampton, where the office of the English Ordnance Survey is located, the personnel consists of about nine hundred persons, of which probably one hundred belong to the army. The map printing establishment has even greater capacity than that at Paris, 3,000,000 maps being delivered annually. Although the great trigonometric work may be considered as finished in England, nevertheless, the topographic work goes on, and the effort is made to cover the whole kingdom once in twenty years with a new map on a scale of 1/2,500, and once in fifteen years with one on 1/10,000. Of course, the latter is made from the former by making blue prints, tracing in black the detail required, and photographing again, which leaves out everything in blue on the original sheet.

E. D. PRESTON,

*Delegate on the part of the United States.*

U. S. COAST AND GEODETIC SURVEY.

THE ANNUAL REPORT OF THE SECRETARY  
OF AGRICULTURE.

THE Report of the Secretary of Agriculture for 1898, just issued, is of interest as showing the growth of the technical and scientific work of the Department. This national agency for the promotion of agriculture now consists of two bureaus, two offices and fourteen divisions, most of which are engaged in scientific inquiries. A few of the more salient features of the work of the Department during the last year may serve to indicate the lines in which it is making progress.

The Weather Bureau has greatly increased the efficiency of its forecast service by the establishment of a considerable number of observation stations in the West In-

dies and additional stations in the more arid regions of the West. A climate and crop service has also been begun in Alaska.

The Bureau of Animal Industry has had great success in its experiments for the repression of hog cholera by the use of specially prepared serum. The experiments in dipping cattle to kill the ticks which cause Texas fever have also been successfully conducted on a large scale.

The work of the Division of Chemistry on the composition and adulteration of foods and on sugar beets has been quite extensive. Studies of typical soils in the vegetation house by the Division have shown that "Meteoric influences other than those relating to precipitation have a great influence on crop production. The solar influences are evidently of great importance, and the distribution of solar heat is a factor not to be neglected."

Among the more important investigations of the Division of Entomology have been those on the Morelos orange fruit worm, the Mexican cotton-boll weevil, chinch bug, Hessian fly and San José scale.

The Biological Survey is energetically pushing its researches on the life zones of the United States.

The Division of Vegetable Physiology and Pathology has made interesting investigations relative to increasing the sugar and starch-producing power of plants and the effect of soil foods on their growth and productiveness. A large amount of hybridizing has also been done with oranges and other citrus fruits, pineapples, pears, wheat and other crops.

Our knowledge of the native forage plants of the Great West has been considerably enlarged by the recent work of the Division of Agrostology, which has added nearly 3,000 sheets of specimens to the National Herbarium during the year.

The Division of Soils has perfected and cheapened its electrical apparatus for the

determination of soil moisture and has begun the detailed mapping of soil areas adapted to different crops.

The Division of Forestry has been reorganized under its new Chief and will devote itself more largely to experiments on a relatively large scale in the economic management of forest lands and the reforestation of the Western plains.

Besides its work on the National Herbarium, the Division of Botany is enlarging its studies of seeds and has recently been charged with the supervision of seed and plant introduction from foreign countries, for which the Department already has several agents at work in different countries.

The method of crop reporting has been improved under the direction of the present Chief of the Division of Statistics, and special economic investigations, such as those relating to the cost of producing a bale of cotton and the world's consumption of wheat, have been undertaken.

The Section of Foreign Markets has issued timely and valuable reports on the commerce of Hawaii, Spain and Puerto Rico.

The Office of Experiment Stations, besides general supervision of the expenditures of the 53 experiment stations, preparation of the Experiment Station Record and other publications based on the work of the stations, has had the direction of special investigations on the agricultural capabilities of Alaska and on the food and nutrition of man. Recently this office has also been charged with investigations on irrigation, which are to be carried on in cooperation with the experiment stations and State engineers in the irrigated region. In connection with the nutrition investigations, the Atwater-Rosa respiration calorimeter has been so far perfected that "not only the nutritive value of the food consumed, but also its relation to the heat and energy evolved by the human body during periods of rest and

work have been measured with a completeness and accuracy hitherto unknown."

The examination of the work and expenditures of the agricultural experiment stations by the Office of Experiment Stations during the past year has shown that these institutions are, as a rule, working more thoroughly and efficiently than ever before for the benefit of American agriculture. More than six hundred persons are employed in the work of administration and inquiry. About four hundred reports and bulletins were issued by the stations in 1897, which were directly distributed to over half a million addresses, besides being widely reproduced in the agricultural and county papers. The appropriation of \$720,000 from the National Treasury for the support of the stations was supplemented by State funds aggregating over \$400,000.

"The need and value of scientific researches on behalf of agriculture are now very clearly understood, and the number and importance of institutions organized for this work are constantly increasing in all parts of the world. Nowhere has so comprehensive and efficient a system of experiment stations been established as in the United States. In the scope and amount of their operations, and in the thoroughness with which the useful information they obtain is disseminated among the farmers, our stations are unsurpassed. During the ten years which have elapsed since the Hatch Act went into effect a very large amount of accurate information of direct practical benefit to our farmers has been published by the stations. Not only have the numerous bulletins and reports of the stations been freely distributed in all parts of the country, but many valuable books largely based on the work of the stations have been written for the farmer's use, while the agricultural press has busily collated and disseminated a vast amount of information directly relating to the work



of the stations or supplementary to it. The contrast between the correct information regarding the principles and practices of his art easily obtainable by the farmer of to-day and that available for his predecessor a generation ago is very wide and striking."

The Secretary strongly urges that the stations should more fully devote themselves to original investigation in behalf of agriculture.

"Political considerations should have no place in the choice and retention of station officers; college duties should not be allowed to encroach upon the time set apart for original investigation, and the compilation of old information should always be made secondary in the acquirement of new knowledge.

"The stations are not the only means for the education of the farmer. Agricultural colleges, farmers' institutes, boards of agriculture and various other agencies have been established to instruct the farmer regarding the present status of agricultural science as applied to his art. It is the business of the experiment stations, on the other hand, to advance knowledge of the facts and principles underlying successful agriculture and to teach the farmer new truths made known by their investigations. The Act of Congress creating the stations clearly defines their functions to be the making and publishing of original investigations. Wherever a station has neglected this and merely endeavored to educate the farmer we find a weak station, and wherever a station has earnestly devoted itself to original investigations we find a strong station."

The Secretary also heartily commends the movement to secure the introduction of nature-teaching into the common schools, and favors the providing of special privileges for graduate students in the scientific divisions of the Department.

In general, the tone of the Secretary's Report is very encouraging to the scientific workers of the Department, for, while he strongly insists on the necessity of bending every energy to the securing of results of wide practical application, it is clear that he believes that this end can be most certainly and effectively reached by broadening and strengthening the scientific researches of the Department.

The following schedule indicates in brief the present development of the Department as an agency for research and education in agricultural science.

THE DEPARTMENT AS AN AGENCY FOR RESEARCH AND EDUCATION IN AGRICULTURAL SCIENCE.

Weather Bureau : Researches in climatology and meteorology.

Bureau of Animal Industry : Researches on animal diseases, including chemical, bacteriological and zoological investigations.

Division of Statistics : Collection and study of agricultural statistics.

Division of Entomology : Researches on life history and geographic distribution of insects and on means of repression of injurious insects.

Division of Chemistry : Researches on soils, fertilizers, foods, sugar-producing plants, methods of analysis, etc.

Division of Botany : Researches on the natural history, geographic distribution and utilization of plants, special studies on seeds and on poisonous and medicinal properties of plants, and collection of seeds and plants from foreign countries.

Division of Forestry : Researches on the natural history, biology and utilization of forests and forest trees and on timber physics.

Division of Biological Survey : Researches on the geographic distribution of plants and animals and on food habits of birds and mammals.

Division of Pomology : Studies on varieties of fruits and nuts.

Division of Vegetable Physiology and Pathology : Researches on the physiology and diseases of plants.

Division of Soils : Researches in agricultural physics, especially on the physical properties, moisture, temperature, etc., of soils.

Division of Agrostology : Researches on natural history, geographical distribution, and utilization of grasses and forage plants.

Office of Road Inquiry: Experiments in road engineering.

Office of Experiment Stations: Collection and dissemination of information regarding agricultural education and research in the United States and other countries. Supervision of cooperative investigations on the food and nutrition of man and on irrigation. Investigations on the agriculture of Alaska.

The Library: Contains 63,144 volumes, largely on agriculture and agricultural science. The library is engaged in the preparation of bibliographies of subjects in agriculture and agricultural science.

Publications: During the year ended June 30, 1898, the Department issued 501 bulletins and reports, the total number of copies being 6,280,365, exclusive of the Yearbook, which has an edition of 500,000 copies, and also of the publications of the Weather Bureau.

A. C. TRUE.

THE BREEDING OF ANIMALS AT WOODS HOLL DURING THE MONTHS OF JUNE, JULY AND AUGUST.

DURING the month of June the temperature of the water continues the regular increase which begins on the first of April, and toward the end of the month reaches the temperature of 65° F. During July of the present year it fluctuated between 66° F. and 71° F., and during August it frequently registered 72° F.

With the increased temperature of the month of June there is a corresponding increase in the number of breeding animals; indeed, this month indicates the culminating point of reproductive activity of marine organisms at Woods Holl. The months of July and August are characterized by a constantly decreasing number of breeding animals, though the high temperature of the water is conducive to the rapid growth of innumerable larvæ.

*Vertebrates*.—Breeding lampreys have been taken at East Taunton as late as June 17, and the eggs hatch in from eleven to fourteen days. The smooth dog-fish, *Galeus canis*, frequently gives birth to 'pups' while confined in the 'fish cars' during this month. These young, beautifully marked,

swim about with their parents, and do not seriously suffer from their restricted quarters. The fishermen say that the 'smooth dog' has two broods, and the observations made at the laboratories would indicate that this view is correct. The first brood is generally dropped during the early part of June, though during the latter part of the month a few females are often found with fully developed young. It is probable that, as soon as the young are born, mature eggs leave the ovary and pass into the oviduct, where they become fertilized. Professor W. A. Loey has removed eggs from the oviduct, which were in segmentation stages, from as early as June 22 to as late as July 4. Through the early part of July the embryos are small, but during August only advanced stages are found. The second brood may be dropped as early as August 10th.

The belief that the females after giving birth to their first brood immediately breed again is supported by Dr. Ayers, who has noted that there are congested placental spots on the uterine walls of individuals, the oviducts of which contain active spermatozoa, and Dr. Loey has noted that the ovaries contain certain large ova during June, whereas they contain only smaller eggs after the early part of July. No individual, however, is actually known to have given birth to two broods in a single summer.

The sand shark, *Carcharias littoralis*, the most common shark at Woods Holl during the summer, so far as I know, has never been taken during the breeding season, all the individuals being apparently immature. The spiny dog-fish, *Squalus acanthias*, though at times abundant during the early spring, has not been taken in sufficient numbers during recent summers to be of special value. Those desirous of collecting embryological material of this species have generally gone to North Truro, Province-

town or Lanesville. During the latter part of June segmentation stages and early embryos are found. During July embryos of about 1 cm. prevail. Early in August the embryos have reached a length of about 2 cm., and during the latter part of August embryos from 3 to 7 cm. in length are most abundant.

The common skate, *Raja erinacea*, is abundant during June, July and August, and at times fully a bucketful of eggs have been deposited in the 'fish cars' in a single night. The ripe females may be distinguished by the color of the lower side of the abdomen, through the thin walls of which the ova may be felt and even seen. Torpedoes with ripe eggs have not been taken. The short-nosed sturgeon, *Acipenser brevirostis*, is occasionally taken in June, the females bearing ripe eggs. The menhaden, *Brevoortia tyrannus*, breeds during the month of June, though no young were taken the present year. By the middle of July schools of young fish of about one inch in length are often to be seen.

*Fundulus majalis* continues its breeding during June and early July, and its eggs may be artificially fertilized with the sperm of *Fundulus heteroclitus*. The latter species breeds abundantly from the middle of May until the middle of July, but during the latter part of July and the first of August only a few ripe eggs can be secured. *Cyprinodon variegatus* spawns in June. *Lucania parva* is said to be viviparous. I do not know when it breeds. I am informed that late in July the female pipe-fish bears large ovarian eggs, and the males are still carrying embryos in their brood-pouches. Late in August both embryos and pouches have disappeared, and the ovaries contain only immature eggs.

Two species of *Menidia* (*gracilis* and *notata*) abound in the neighborhood of the laboratories. The following has been taken from notes kindly furnished by Dr. C. Judson

Herrick: On June 5, 1896, Mr. Edwards found *Menidia notata* spawning at Hyannis in vast numbers. At this time the fish had selected a point in the beach grass above the low-tide level, and at low-tide the eggs were consequently exposed to the sun and dried. Mr. Edwards noted great quantities of spawn and milt, and collected about a quart of the former. During the last days of June and the first ten days of July of the present year the fish were very scarce, though Dr. Herrick found a few ripe females and a very few males. The eggs adhere to each other in thick ropy masses, and to any foreign object with which they come in contact, by means of long threads. Both fertile and unfertile eggs sink to the bottom, and the first cleavage plane appears in about one hour. The eggs may be artificially hatched in jars of running water, the period of incubation being ten days. The young fish, which carry a small yolk-sac, are about 6 mm. in length. Fry were skimmed from the surface of the harbor on July 4th, and measured 1.5 cm. in length. On July 9th fry similarly taken measured 2.25 cm. in length.

The eggs of *M. gracilis* resemble those of *M. notata*, but the species seems to breed later, since many ripe females were taken during the first week in July. The eggs, however, do not undergo artificial fertilization as readily as those of the first species.

The mackerel, *Scomber scombrus*, breeds during the middle and latter part of June, and generally at some distance from the shore. During the early part of the month of August of the present year myriads of young fish, about two inches in length, were found in the southern portion of Massachusetts Bay, showing that the breeding had taken place much nearer the shore than is usual. The butter-fish, *Rhombus triacanthus*, breeds during June. The white perch, *Morone americana*, breeds in May and June, and the sea-bass, *Centropristes striatus*, from



the middle of May to near the first of July. The scup, *Stenotomus chrysops*, spawns during early June, but the eggs do not all become ripe at the same time. Though thousands of squeteague were taken in the fish-trap during July, not a single individual contained spawn, and this was not surprising; for, according to Dr. Hugh M. Smith' spawning occurs about June. The cunner, *Tautoglabrus adspersus*, spawns during June and early July, and the bright colored young are abundantly found throughout the latter part of the summer. Ripe tautog, *Tautoga onitis*, were 'stripped' on June 15th and ripe eggs might have been taken until the middle of July. The 'puffers' are also summer breeders, the spawning season occurring early in June, after which the young are frequently taken in the skimming-net.

Since the establishment of the biological laboratories at Woods Holl the toad-fish has contributed to science with great generosity. Tin cans, broken bottles and shattered fragments of crockery are regularly planted by the collectors, and are regularly lined with large golden eggs. Oviposition occurs as early as June 3, and it may occur at any subsequent time throughout the month. According to Dr. Hugh M. Smith the blue-fish arrives about June 1st, at which time well-developed ova are found in a small proportion, and at Nantucket large roes have been found as late as July 15th. The first young blue-fish were taken at Woods Holl on June 10th, and measured from  $1\frac{1}{2}$  to  $1\frac{1}{2}$  inches in length. The young of the mullet, *Mugil curema*,  $1\frac{1}{4}$  inches in length, were taken on June 28th. Both species of sea-robin breed during the early part of June. The eggs, not particularly transparent, readily develop in the laboratory and hatch in about five days. After the first of July females with eggs are seldom taken.

Among the Pleuronectidæ, *Bothus maculatus* breeds during early June, and the eggs

may be artificially hatched, the period of incubation being about eight days. The young of 'flat-fish' were taken in the tow-net by Mr. S. R. Williams, from the 4th to the 17th of June, on which latter date they were most abundant. A few were also taken during the latter part of the month and during July. I have the following interesting note from Mr. Vinal Edwards: "A large school of young cod placed in the 'Eel Pond' directly from the hatching jars, in December last, left the pond in June when the water reached a temperature of about 60° F. They were at this time from 2 to  $4\frac{1}{2}$  inches in length." The spawn of the goose-fish is occasionally taken near Menimsha. When a spawn is found, an abundance of embryological material results, since the eggs are united in a great jelly-like band that will more than fill a bucket.

The auftrieb is not rich in surface vertebrates during the summer. In June young hake, pipe-fish, lump-fish and herring occasionally occur. In early July young swell-fish, cunners, sticklebacks, tautog, sand-eels, silversides, hake and sand dabs; and during the middle of July the swell-fish, cunners, sticklebacks, silversides, sand-eels and hake are still conspicuous, though gradually disappearing from the surface as the season advances. By the middle of August only occasional specimens are taken.

Two species of land turtles are abundant in fresh-water ponds near the laboratories. The painted turtle, *Chrysemys picta*, breeds from June 11 to 25, and deposits its eggs in the evening, from 6 to 8:30 o'clock. The snapping turtle also breeds during the middle of June, but it deposits its eggs in the early morning.

*Ascidians*.—I am indebted to Frank W. Bancroft for many of the following notes respecting the breeding of ascidians.

*Appendicularia* were abundant near Gay Head on July 28th, and *Doliolum* is often taken at the same locality. Farther from

the shore several species of *Salpa* occur in abundance.

Among the simple ascidians, *Molgula* may be obtained in abundance from the woodwork in the harbor of New Bedford, and I think the eggs are ripe throughout the summer. *Cynthia partita* is apparently ripe throughout the month of July, at which time Dr. Bancroft also found ripe *Ciona intestinalis* and *Perophora viridis*.

Among the composite ascidians, *Botryllus goddii* was found breeding from the sixth to the end of July, and almost all the older colonies contained either large ova or embryos. This species was not examined before the sixth, nor after the close of the month. Though several colonies of *Amarcium stellatum* were examined, no large eggs or embryos were found during July, although *A. constellatum* frequently had large ova and embryos.

*Crustacea*.—There are several Brachyurans that carry eggs during the summer months. *Gelasimus minax*, *pugnax* and *pugillator* breed during the early parts of June, and females with eggs occur as late as July 2d, and perhaps later. *Sesarma reticulata* I frequently have found with eggs, but no specific data are at hand. *Pinnixa cylindrica* was found with eggs on July 13. *Pinnotheres maculatus* has been studied by Mr. F. P. Gorham, who found that the animals were very active at night, leaving the seclusion of the mantle-chamber of the mussel, and swimming and crawling about in the water in a most restless manner. On July 9 eggs in the earliest stages of development were taken, and from then until August 29 Mr. Gorham found all stages, though at the latter date egg-bearing females were relatively less abundant. *Panopeus* was found with eggs on June 7, and gastrulation stages were found on July 1. On July 8 all stages from four cells to complete embryos were noted, and on July 12 two females deposited eggs while

in captivity. *Carcinus granulatus* was found with eggs, in late stages, June 25. *Platyonichus ocellatus* carried late stages on July 3. *Callinectes hastatus* was found with advanced embryos on August 3. *Libinia* has been seen to oviposit as late as August 7. *Pelia mutica* bears beautiful transparent eggs, which are in early embryonic stages the first week in July.

Among the Anomoura, *Hippa talpoida* carries eggs in the latter part of June and throughout the month of July. Mr. Gorham found early embryos and free-swimming young on August 9, 1896, and the characteristic Zoea are conspicuous in the skimmings throughout the month of August, being most abundant on the 22. Mr. M. T. Thompson found *Eupagurus longicarpus* with eggs until the middle of September. *E. annulipes* was not brought to the Laboratory before the early part of September, but at that time the females had eggs in varying stages of development. The breeding habits of *E. bernhardus* and of *E. pollicaris* were not noted, though the skimmings yielded an abundance of Zoea from the first of August throughout the month, and were probably present still earlier. The 'Glaucothoe stage' was first found on the 12th of August, and was frequent thereafter throughout the month.

Zoea of various species are conspicuous in the surface material from the first week in June, and Mr. S. R. Williams noted that when they were abundant they seemed to exclude 'Megalops' and *vice versa*.

Among the Macroura, *Gebia affinis* was found with advanced eggs on July 25. These hatched on August 7. *Callinassa stipsoni* was found with eggs on July 1, and again on July 13. On the latter date the eggs were in segmentation stages. On July 18 other specimens bore advanced embryos which hatched on July 21. Dr. F. H. Herrick for several years had the opportunity of examining many

lobsters at the Fish Commission Hatchery, and concluded that the larger number of eggs were laid during the latter half of July and the first two weeks of August. These eggs are normally carried by the female until the following spring, when they hatch during May, June and July. I regret that I have no specific data on the breeding habits of *Crangon vulgaris*, but I have every reason to suppose that it is bearing and hatching eggs with its characteristic industry. Mr. F. P. Gorham found *Virbius zostericola* carrying eggs in all stages of development from the first of June to the first of September; the period of incubation lasts for about two weeks. *Palemonetes vulgaris* was found with eggs in early stages of segmentation on June 20, and on the same date other individuals were found bearing late blastoderm stages and fully-formed embryos. The larvæ of *Palemonetes* are excessively abundant in the auftrieb during July and August. The young of *Squilla* was occasionally taken in the tow-net during August, and was abundant on the surface of the Gulf Stream. A beautiful *Heteromysis*, bearing deep green eggs, was frequently dredged on the shelly bottom east of Nobsque during June and July. The young of *Cuma* were taken in the skimmings on June 14.

The Amphipods are by no means as abundant as during the spring. Mr. F. M. Watson found *Amphithoë compta* breeding through July and the first week or two of August and *Calliopius levinsulcus* with eggs on August 1. *Orchestia agilis* was represented by innumerable young during the first two weeks in July; *Podocerus falcatus* was taken with eggs during the last two weeks of July and the first two weeks of August. Early in August a large number of Caprellæ bearing eggs were taken. *Talorchestia* has been found with eggs in late stages of development on June 14, and *Orchestia agilis* with eggs and embryos on June

20. A tube-dwelling amphipod, probably *Cerapus tubularis*, bears eggs, some of which are in early stages of development on July 4. *Hyperia* is frequently taken during June, and its large, almost absolutely transparent eggs would form excellent material for certain lines of biological research.

Among the Isopods, *Idotea robusta* was found with eggs on July 17, and again on August 12. Dr. J. P. McMurrich has found *Jera marina* breeding in the middle of June, when his first observations were made, and from then without interruption until the first week in September, the time of his departure from the laboratory. *Tanais vittatus* was found with eggs in various stages of development early in August, and Dr. W. M. Wheeler has found the eggs of *Armadillidium vulgare* around old logs at Butler's Point late in June.

Copepods are, of course, abundant in all the surface material, and the parasitic Copepods found attached to the various fishes almost invariably bear egg-capsules which contain embryos in various stages of development. Attached to the floating seaweeds, boards, etc., which are washed on to the shore from the ocean are two or three species of 'goose barnacle,' which yield abundant embryonic material.

Dr. Wheeler found *Limnetis gouldii* breeding in small fresh-water ponds on Penzance, June 6-13, 1892. Associated with these were many specimens of *Eulimnadia agassizii* and *Bosmina*, both sexually mature.

The Pycnogonids breed during July, August and September. Dr. T. H. Morgan has recorded the appearance of *Tanystylum orbiculare* with eggs on July 1st; *Pallene empusa* carries eggs throughout the summer, and *Phoxichilidium maxillare* during August and September.

*Limulus* was found depositing eggs on June 19, and eggs were artificially fertilized on July 12, though the females were then nearly spent.



*Vermes*.—The breeding season of *Lepidonotus* and *Harmothoë* has passed. The eggs of *Sthenelais* may be artificially fertilized, and ripe individuals have been taken during the middle and latter part of August. *Podarke obscura* begins to oviposit about July 1. Dr. A. L. Treadwell has succeeded in artificially fertilizing the eggs by keeping the males and females in separate dishes until the sexual products are extruded, and then mixing in the ordinary way. *Autolytus* and other Syllids are frequently taken in the skimmings; the eggs are held in small spheres under the abdomen. *Nereis limbata* and *N. megalops* may be taken at the surface, in the evening, in great numbers and during the entire summer. The breeding habits of *Diopatra* are unknown, though the ova are nearly ripe in August. Though many specimens of *Marpysa* have been collected, the time of sexual maturity is not known. The breeding habits of *Anthostoma* and *Trophonia* are also unknown. Dr. A. D. Mead informs me that *Cirratulus grandis* breeds during July, and that the females will deposit their eggs while in confinement. The eggs are of fair size, but very opaque. Oviposition takes place in the evening. On the breeding habits of *Maldane* and *Cistenides* I have been unable to collect specific data.

Dr. Mead has spent a great deal of time in determining the breeding period of *Amphitrite ornata*, and after collecting about eight hundred specimens, at various times of the year, concludes that there is no definite breeding season. Between the first of June and the last of August only occasional individuals were found which yielded ripe sexual products. The eggs are extruded during the evening, and will not fertilize if artificially removed from the body cavity. *Seionopsis palmata* was found to bear eggs, apparently ripe, in August, but artificial fertilization was not attempted. The eggs of *Serpula (Hydroides)* may be readily secured

by simply crushing the worm-tubes, and then placing the somewhat injured female in sea-water. As soon as the males are taken from the tubes the sperm will be seen to ooze from the nephridial openings. *Spirorbis borealis* is frequently found with eggs and embryos. From the latter part of June to the latter part of July the eggs of *Arenicola* may be collected by the bucketful. They are extruded in a jelly-like mass, sometimes two feet in length, and are especially abundant on the warm sand-flats of Buzzard's Bay.

Dr. Mead obtained the eggs of *Chaetopterus* during July and August by cutting open the females. During the early summer of 1892 the larvæ of *Polygordius* were exceedingly abundant, and few specimens were taken during the past summer. *Sagitta* occurred occasionally. It was noted by Mr. S. R. Williams during the middle of June, and again at the close of the month and early in July.

*Neetonema* was occasionally brought into the Laboratory, and Dr. H. B. Ward has known it to extrude its eggs while in dishes of sea-water.

Dr. E. G. Gardiner informs me that he has taken the orange-colored eggs of *Polychaerus caudatus* as early as June 6, and that they are abundant from June 15 to August 25. The eggs are deposited at night in transparent gelatinous capsules.

'Tornaria' larvæ are often taken during August in great abundance at flood tide, during both day and night.

*Echinoderms*.—Previous notes in SCIENCE have called attention to the early breeding habits of several representatives of this group. *Echinaraechnius parma* continues to breed throughout June and the early part of July, and a limited number of eggs may be secured even during the later portions of the summer. *Arbacia punctulata* yields ripe eggs during the latter part of June, throughout July and a portion of August.

*Strongylocentrotus* was not carefully examined, though at Nahant I have often noted the extrusion of the yellowish, opaque eggs at various times during the warmer months.

The breeding habits of the star-fish are peculiar. Dr. A. D. Mead has found the breeding period to culminate in Narragansett Bay during the last week of June, although at Woods Holl no considerable number reached sexual maturity at any time during the past summer. In 1892 larvæ were abundant on June 18.

Mr. Caswell Grave paid particular attention to the Ophiurids during the past summer, and was successful in getting many ripe specimens of *Ophiopholis aculeata* at Nahant during the month of June. These he brought to the Laboratory in sea-water, artificially cooled, and they deposited their eggs and sperm between eight and nine o'clock in the evening of the day they were collected. The development was slow, the 'pluteus stage' being reached not until three weeks after fertilization, and several of the plutei lived to be thirty-three days old without showing signs of metamorphosis. Mr. Grave followed the development of the sexual glands of *Ophiura olivacea* with great care from the first of June, but the period of sexual maturity was not reached until the second week of July, when a limited quantity of fertilized ova was obtained. The larvæ proved to be quite different from those of any previously described Ophiuran. *Thyone briareus* and *Synapta inhærens* (= *Synapta girardii*) probably breed during June and July. I think the eggs have never been artificially fertilized. Echinoderm larvæ, which may have been brought to Woods Holl by currents, were abundant during the middle of June. Brachiolaria swarmed in Narragansett Bay from the last of June to the middle of July.

*Mollusks*.—During the first week of June the young of *Mytilus*, the 'sand-collars' of *Lunatia*, the 'eggs-strings' of *Sycotypus*

and the 'egg-capsules' of *Urosalpinx* were noted in Narragansett Bay. During the second week of June, *Crepidula*, *Urosalpinx* and several naked Mollusks were found ovipositing. Dr. F. R. Lillie has collected eggs of *Pecten* from July 10 to August 4. On August 17 the breeding period had passed. According to Dr. Conklin the breeding period of *Crepidula fornicata* lasts from early summer until about August 15. The breeding period of *Crepidula plana* is somewhat later and longer, and newly laid eggs were found September 7. *Crepidula convexa* lasts through much the same period as *C. plana*. Dr. Lillie says that the unsegmented ova of *Unio complanata* can be obtained from about the middle of June to the middle of July, those of *Anodonta* toward the end of July and early in August. The 'Glochidia' of *Unio* escape in August and September, and the eggs of *Anodonta* are carried by the mother through the winter and are extruded in the spring.

Small squid were taken on the surface from June 20 to the close of the summer.

The clam, *Mya arenaria*, breeds during June and perhaps earlier. The height of the breeding season of the oyster is during the latter part of July, and the development is so rapid that the young swim in less than six hours after fertilization.

Mr. S. R. Williams, who kept a record of the surface forms during the past summer, found 'veligers' abundant on June 12, July 9 and July 19.

*Cœlenterates*.—*Cyanea arctica* has been taken with ripe eggs as late as June 3, though by the middle of the month only occasional specimens are seen. The eggs readily fertilize, and the young develop freely in the aquaria. The 'Ephyrae' of *Aurelia* were taken in the tow on June 15. The Scyphomedusæ are not abundant at Woods Holl during mid-summer, an occasional *Dactylometra* or an immature *Cyanea* being almost the sole representative of the

group. At New Bedford, and in Narragansett Bay, *Dactylometra* is excessively abundant, and one would probably have little difficulty in getting material for embryological study at almost any time. *Metridium* has frequently been seen to extrude its eggs, which may be artificially fertilized, and *Sagartia* has also been found breeding during the middle of July.

I am indebted to Professor W. C. Hargitt for many of the following notes on the breeding of Hydroids:

*Clava leptostyla*.—Colonies are occasionally taken from rock-weed in the 'Hole,' from June 18 to the end of the month, and less frequently throughout the summer. Colonies may also be taken from exposed timbers under the wharf of the U. S. Fish Commission. The male colonies are much more abundant and conspicuous.

*Clytia bicophora*, on the shells of *Mytilus*, with colonies of *Eudendrium*, is abundant late in June, when it is in a thrifty condition, and with mature gonangia.

*Eudendrium*.—Colonies of *Eudendrium*, probably *E. ramosum*, were taken in very imperfect condition June 17, apparently just beginning development from old stolons. Specimens were also taken from under the culvert at the outlet of the Eel Pond, on June 20, in a more vigorous condition, but with only male gonophores, which contained ripe spermatozoa. Colonies developed rapidly during the following ten days and produced female gonophores. The earliest signs of development of eggs occurred during the first week of July. The latest were recorded by Dr. Murbach, on September 15.

*Corynitis Agassizii*.—Specimens taken from the wharves of the Fish Commission on June 20, on shells of *Mytilus*, were in a thrifty condition and bore mature medusæ. These are set free during the early evening, and swim actively about the aquarium, though at this time there are no indications

of sexual products. Several colonies of this interesting Hydroid were taken, but always from the encrusting deposit of a Bryozoon, which frequently occurs on the shells of *Mytilus*.

*Hydractinia (Echinata) polyclina*.—Colonies taken from the shells of Eupagurids, from rock-weed and from *Limulus*, were mostly sterile in June, or with only male gonads. It breeds during July and August.

*Margelis carolinensis* is quite common and in an excellent state of growth during June, though without medusa-buds. It is found on the timbers of the Fish Commission docks, on rock-weed and occasionally upon eel-grass. It breeds during August.

*Obelia sp.*—A species of *Obelia* is very abundant along the rock work and wharves, and during June develops apparently ripe gonangia, though few free medusæ.

*Parypha crocea*.—In splendid profusion and perfection throughout the month of June.

*Pennaria tiarella*.—During the month of June this species is to be found in limited numbers attached to rock-weed and to the piles of the wharves. Its development is slow, specimens with medusa-buds not being taken until June 29. During the following weeks the development is more rapid, both of the polyp-stock and of the medusæ. Dr. Murbach has found the species breeding as late as September.

*Sertularia sp.*—Everywhere in abundance, but with gonangia only in a few cases. Several species are found, of which the commoner are *Pumila* and *Argentea*.

Dr. McMurrich found *Laomedea amphora*, on Fucus, with ripe gonophores, June 2, and associated with it was *Halecium*, in a similar sexual condition. During the latter part of June and throughout the summer the medusæ of *Gonionemus* is found in great quantities in the Eel Pond. Mr. Williams noted *Clytia* and *Lizzia* in the sur-



face fauna during the second week of June, and meduse of *Eucopa* were found at various times during the summer. On July 28 an undetermined species of Hydromedusa was so abundant at Menimsha that a tumbler simply dipped into the ocean would be more than half filled with them.

Dr. Murbach has found *Corynitis* breeding during July and the early part of August, *Podocoryne* and *Hypolytus* during August.

Ctenophores, frequent during the early part of summer, literally swarm during the latter part of August. *Mneniopsis* is the most abundant species.

H. C. BUMPUS.

#### AN AMPERE BALANCE.\*

THE Report of the Committee on Electrical Standards for 1897 ended with the following paragraph: "It thus appears to be a matter of urgent importance that a redetermination of the electro-chemical equivalent of silver should be made and that the general question of the absolute measurement of electric currents should be investigated \* \* \*". This work we were asked by the Committee to carry out, and a grant of £75 was voted in its aid. We were thus led to examine into the methods which had been employed by Lord Rayleigh, Professor Mascart and others, for determining the absolute value of a current, as well as to consider some other methods which have not, as far as we know, been hitherto used.

After much consideration we decided to adopt a form of apparatus which, while generally resembling the type employed by some previous experimenters, possessed certain important differences; and, before expending any part of the grant of £75, to construct, without expense to the British Association, the following preliminary Ampere Balance.

On a vertical cylinder about 17 inches high and 6.3 inches in diameter we wound

two coils, about 5 inches in height, separated by an axial distance of 5 inches. The coils consisted each of a *single* layer of about 170 convolutions of wire and were wound in opposite directions. From the beam of a balance there was suspended, inside this cylinder, a light bobbin about 4 inches in diameter, on which was wound a coil about 10 inches long, consisting of a *single* layer of 360 convolutions, and the whole apparatus was so adjusted that when the beam of the balance was horizontal the inner and outer coils were coaxial and the top and bottom of the inner suspended coil were respectively in the mean planes of the outer stationary coils.

This arrangement was adopted because with coils consisting of only one layer the geometrical dimensions could be accurately determined, and because the shapes of the coils lent themselves to the use of the convenient formula, readily expressible in elliptic integrals, for the force,  $F$ , between a uniform cylindrical current sheet and a coaxial helix, viz:

$$F = \gamma \gamma_h (M_1 - M_2),$$

where  $\gamma$  is the current per unit length of the current sheet,  $\gamma_h$  the current in the helix, and  $M_1$  and  $M_2$  the coefficients of mutual induction of the helix and the circular ends of the current sheet.\*

The value of a particular current of about 0.63 ampere having been determined *absolutely* by means of this apparatus, the rate at which it would deposit silver under specified conditions was ascertained indirectly, by observing its silver value on a Kelvin balance which had been kept screwed down in a fixed position for several years past and which had been calibrated many times

\* Proceedings of the Royal Society, Vol. 63, "On the Calculation of the Coefficient of Mutual Induction of a Circle and a Coaxial Helix, and of the Electro-magnetic Force between a Helical Current and a Uniform Coaxial Circular Cylindrical Current Sheet," by Professor J. V. Jones.

\* Read before the British Association.

during that period by reference to the silver voltameter.

The result of this preliminary investigation showed that the silver value of the *true* ampere was so nearly equal to the reputed value, viz., 1.118 milligram per second, as to require the use of an apparatus still more perfectly constructed, and, therefore, of a much more expensive character to enable the error, if any, in this value to be ascertained with accuracy.

We, therefore, started on the design of the instrument, of which we now submit the working drawings, and for the future construction of which we would ask for a grant of £300, including the unexpended grant of £75 voted last year.\* And we anticipate that this new piece of apparatus may prove worthy of constituting a national Ampere Balance, the counterpoise weight for which will be determined purely by calculation based on the dimensions of the instrument, the number of convolutions of wire in the three coils, and the value of the acceleration of gravity at the place where the instrument may be permanently set up. In this particular it will differ entirely from the 'Board of Trade Ampere Standard Verified 1794,' which has had its counterpoise weight adjusted so that the beam is horizontal when a current passes through the instrument, which will deposit *exactly* 1.118 milligram of silver per second under specified conditions. In fact, the proposed Ampere Balance and the existing Ampere Standard will differ exactly in the same way as do a Lorenz apparatus and the 'Board of Trade Ohm Standard Verified, 1894.'

We have to express our thanks to Mr. Mather for taking charge of the construction and use of the preliminary apparatus, for checking all the calculations in connection with the determination of the electrochemical equivalent of silver that was made with it, as well as for superintending

\* This grant of £300 has since been made.

the making of the working drawings of the new Ampere Balance.

We have also to thank Messrs. W. H. Derriman and W. N. Wilson, two of the students of the City and Guilds Central Technical College for their cordial assistance in carrying out the work.

W. E. AYRTON,  
J. VIRIAMU JONES.

#### NOTES ON PHYSICS.

##### ELECTRICAL VIBRATIONS.

IN *Wied. Ann.*, 1898, No. 11, M. Abraham gives a solution for the electrical oscillation of an ellipsoidal conductor (ellipsoid of revolution) and an approximate solution for the electrical oscillation of a straight rod. Perhaps the most interesting feature of the paper is the detailed analysis of the reflection of an electrical wire-wave from the free end of the wire.

The wave-length of the Hertz waves sent out from a vibrating rod are shown to be the double length of the rod, a fact which has been known experimentally for some time, and the overtones are harmonic.

It may be remembered that Tesla, a few years ago, suggested (and perhaps tried!) the use of electrical oscillations of the earth as a means of telegraphy. The solution of the problem of the electrical oscillation of a sphere was well known (?) at the time, and this solution indicates that to maintain the electrical oscillations of a sphere only a few inches in diameter would require *millions of horse-power*, and, of course, to stir up the earth electrically would require an enormously greater amount. Tesla did not succeed.

##### MANOMETRIC FLAMES.

PROFESSORS NICHOLS and Merritt publish, in the August number of the *Physical Review*, an interesting series of manometric-flame photographs. The reproductions are as good, perhaps, as is possible, but the original

negatives, which the writer has had the good fortune to see, are very fine, indeed, and show an amazing amount of detail in case of both consonant and vowel sounds. The photographs were taken by using acetylene burning in oxygen, an image of the flame being thrown upon a moving sensitive film.

## ETHERION.

*Nature*, in acknowledging the receipt of a paper by Mr. Charles F. Brush (*sic*) on the new gas *Etherion*, promises to "refer to the paper later when we receive a spectroscopic demonstration of the existence of the new gas." It seems to the writer that Mr. Brush has demonstrated the existence of a gas—or something thin like air—which has a thermal conductivity one hundred times as great as that of hydrogen. If such is the case, the gas is certainly a new gas, and perhaps the spectroscope cannot be expected even to *verify* its existence; for Mr. Brush's speculation as to its molecular weight (1/10,000) is to a certain extent legitimate, and perhaps a gas of this molecular weight might not have any spectrum at all. One does, however, feel like demanding the demonstration of the existence of this substance by some of the methods heretofore employed in this field of discovery, but the fact remains that its thermal conductivity is sufficient to establish its existence. The only question in the matter is the accuracy of Mr. Brush's experimental results, and everyone who heard his paper at Boston was convinced of the adequacy of the experimentation. It may interest the readers of *SCIENCE* to learn that Professor E. W. Morley has joined Mr. Brush in continuing the investigation of the new gas.

## THE GRAVITATION CONSTANT.

RICHARZ and Krigar-Menzel\* have finished their elaborate and painstaking determination of the gravitation constant by

\* *Wied. Ann.*, Vol. 66, p. 177.

means of the balance. A preliminary determination of the decrease of gravity with height, begun in '89, was reported to the Berlin Academy in '93.

The resulting value of the gravitation constant is

$$(6.685 \pm 0.011) \cdot 10^{-8} \frac{\text{cm}^2}{\text{g} \cdot \text{sec}^2},$$

and of the density of the earth

$$(5.505 \pm 0.009) \frac{\text{g}}{\text{cm}^3}.$$

This result lies between the results of Poynting and of Boys, and is, no doubt, the best result hitherto obtained; although the estimated probable error of Boys' result is only  $\pm 0.002$ .

W. S. F.

## ZOOLOGICAL NOTES.

## THE BRAIN OF THE CHIMPANZEE.

THE last number of the *Journal* of the Boston Society of Medical Sciences contains an article by E. W. Taylor on the Minute Anatomy of the Oblongata and Pons of the Chimpanzee. The author calls attention to the fact that, while the gross anatomy of the anthropoid apes has received much attention, comparatively little has been done in the way of minute study, and says that particular study should be given the cortex, in which the final secret of the differentiation of brain types must lie. The methods of preparation of the sections are given, and then follows a detailed description and comparison with similar sections of the oblongata and pons of man.

The points of special interest in the oblongata are the great development of the motor tracts; the peculiar conformation of the gray matter; the irregular character of the sensory crossing, and the smallness of the fillet; the fewness of the external ventral arcuate fibers, and the absence of the nucleus arciformis; the large size of the descending root of the fifth nerve and the imperfect development of the restiform body.



The noteworthy features of the pons are the preservation of the identity of the pyramidal tracts; the fewness of the essential fibers of the pons; the greater relative development of the dorsal portions and the insignificance of the posterior longitudinal fasciculus.

Mr. Taylor concludes that "There can be no question from our study, as well as from that which has gone before, that the similarity between the brain of the anthropoid apes and of man is one of the most striking and interesting facts of which we have knowledge."

#### FRESH-WATER PEARLS OF THE UNITED STATES.

MR. GEORGE F. KUNZ's paper on the Fresh-water Pearls and Pearl Fisheries of the United States, recently issued by the United States Fish Commission, is of very general interest. The early history of Unio pearls in North America is given, and the extent to which they were used as ornaments by the aborigines will be a surprise to many. Enormous numbers have been found in the mounds of Ohio, one opened by Mr. Moorehead containing 'a gallon of pearls,' and another excavated by Professor Putnam nearly two bushels. It may be added that through the length of time they had been buried their value from a commercial standpoint had been lost. The various pearl-gathering fevers that have, from time to time, prevailed in different localities are described, and one can scarcely wonder at them when the chance of making a lucky 'find' is considered, even though, as in other lotteries, the blanks far outnumber the prizes. The pearl-button industry which has arisen in some of the Western States has assumed considerable proportions, employing over 1,500 people, and, between the search for pearls and the use of the shells for making buttons, the Unies in many localities are threatened with extermination.

#### THE WASHINGTON MEETING OF THE AMERICAN ORNITHOLOGISTS' UNION.

THE recent meeting of the American Ornithologists' Union—as may be seen by the report of Secretary Sage in the last number of this JOURNAL—was characterized by the large number and wide scope of subjects covered by the papers presented, ranging as they did from those of a popular nature to the strictly scientific. Among the former Mr. Chapman's delightful description of a visit to the Bird Rocks of the Gulf of St. Lawrence easily stands first, accompanied as it was by fine illustrations of the feathered inhabitants of this ancient and historic bird colony. Although the numbers of birds have sadly diminished since Jacques Cartier wrote that these islands are as full of birds as any meadow is of grass, yet enough remain to make a goodly showing, and the white lines of nesting gannets still form an impressive sight.

Dr. T. S. Roberts, of Minneapolis, and Mr. W. L. Bailey, of Philadelphia, exhibited a number of views of birds and their nesting places, some of them veritable triumphs of patience and ingenuity over natural obstacles. This photographing of wild birds and the study of their habits cannot be too strongly commended to our younger ornithologists, not only because it furnishes plenty of good work near home, fraught with no harm to the birds, but because we need to know much more than we do of the habits and life histories of even our commonest birds. The Robin, for example, is a bird so common as almost to be treated with contempt, and yet Mr. Brewster and Mr. Widmann have shown us how much there is of interest about it.

Mr. Witmer Stone, on the part of the Committee on Bird Protection, presented an extensive report encouraging as indicating the growth of sentiment throughout the country. Unfortunately, however, the question of protecting the birds is much

like the temperance question, depending more upon public sentiment than upon law, since laws are inoperative without public approval to enforce them. So long as fashion demands feathers and there are birds to supply them, so long will feathers be worn, and it is to be doubted if laws directed against the wearing of feathers would be held constitutional. Attention was justly called to the collecting fad which possesses so many of our younger ornithologists, and which in its worst phases is not a whit better than the collecting of postage stamps, only to see how many may be obtained. The mere possession of any number of bird skins and bird eggs no more makes an ornithologist than the owning of paints and brushes constitutes an artist, yet it is evident from the abundant catalogues of dealers in bird skins and eggs that there is far greater demand for these than the needs of ornithology warrant. From a scientific standpoint Dr. Jonathan Dwight's observations on the moulting of birds and Mr. William Palmer's on the early stages of feathers were the most important presented, dealing as they did with subjects concerning which we have much to learn, and which have important bearings on the phylogeny and classification of birds. While these subjects have both been worked at in a more or less desultory way, we need a large number of carefully accumulated facts on both points. Mr. Palmer presented a genealogical tree and scheme of classification based on the condition of the neossophtes, or first feathers, but this is to be regarded as purely tentative. While birds must be classified by the resultant of a number of characters, and not by any one or two, yet Dr. Gadow has pointed out the value of taxonomic arrangements based on a single character, since each will contribute something good; therefore, it is to be hoped that Mr. Palmer will continue his work.

F. A. L.

CURRENT NOTES ON ANTHROPOLOGY.

ORIGIN OF NEOLITHIC ART IN FRANCE.

M. GABRIEL CARRIÈRE has an article in *L'Anthropologie*, August, 1898, on the palæthnology of southern France, in the course of which he makes some important general statements. The same population, ethnically, continued after the neolithic period through the bronze age. The introduction of metal was not accompanied by conquest and a change of physical type. The constructors of the dolmens and other megalithic monuments developed their own culture, and their remains have not yielded a single object to which one should attribute an oriental origin, or class with the art products of Hissarlik, Mycenæ or Egypt.

This conclusion is fully in the line of many recent researches in western Europe, which dispel the old notion that its primitive culture was introduced by Phœnician, Greek or Egyptian navigators.

PALEOLITHIC STATIONS IN RUSSIA.

DEPOSITS which can be referred to the Palæolithic period are excessively rare in Russia; indeed, some archæologists deny that any have been found. One rather promising site is on the right bank of the river Dnieper, close to the city of Kiev. In a gravel deposit there, directly overlying the tertiary clay, and at a depth of 19 meters below the surface, M. Chvojka unearthed bones of the mammoth and cave bear, along with flint chips, charcoal and dressed stones of rude form. While the finder believed the deposit of inter-glacial origin, Professor Armachevsky, of the University of Kiev, places it post-glacial; and the types of stone implements, according to M. Volkov, who reports the facts, are not extremely ancient, but point rather to the period of transition from the palæolithic to the neolithic, of which latter period well-marked remains exist in the same locality. This station, therefore, is not certainly very

ancient (Bull. de la Soc. d'Anthropologie de Paris, 1898, Fasc. 2).

#### THE STIGMATA OF DEGENERATION.

THIS is the title of an article of thirty-five pages by Dr. W. C. Krauss in the *American Journal of Insanity*, July, 1897, of great merit. There is no question in anthropology of more actual interest than that of Degeneration, what it is, what it means, what are its signs. In one sense, every step of progress involves degeneration, while in another sense, degeneration is the antithesis of progress. There is no such thing as 'the normal type,' the perfect man, and never was. What some writers assert is the acme of perfectibility—complete adaptation to environment—is, in fact, typical degeneration and a pathological condition.

Dr. Krauss treats very fully the stigmata of degeneration, first the physical, and next the mental or psychological and moral, and concludes with an attempt to answer the question: Is the human race degenerating? He replies with a negative, and adds the pleasing information that, 'as compared with foreigners, Americans exhibit the fewest signs of degeneracy, and the most marked degenerate types found here are imported individuals.'

D. G. BRINTON.

UNIVERSITY OF PENNSYLVANIA.

#### SCIENTIFIC NOTES AND NEWS.

##### THE 'HUMANE' SOCIETY.

THE current issue of the *Philadelphia Medical Journal* contains an interesting article by Dr. D. E. Salmon, Chief of the Bureau of Animal Industry, on diseases and abuses of animals in the United States, describing what has been done by the federal government towards their alleviation and prevention, and what the Humane Societies of the country may do to assist in these efforts. This address was prepared at the request of the officers of the American Humane Society to be read at their present meet-

ing in Washington. But the Washington Humane Society protested that if Dr. Salmon's name were not removed from the program they would lose all interest in the meeting, and the paper was omitted. The Chairman of the Sub-executive Committee wrote to Dr. Salmon that he was deeply humiliated by the action of the Society, and to this letter Dr. Salmon replied as follows:

Your favor of the 21st instant is received, and I assure you there is no cause for you to feel embarrassment on my account. It is remarkable, however, that the Washington Humane Society should so greatly fear the reading of a paper before your body, upon such a practical subject as I was to present, that it would lose all interest in the meeting in case that part of the program were carried out. If the cause which they are advocating would be so seriously endangered by one man and one paper, with a convention predisposed in their favor, should not this confession of the fact prove embarrassing to them rather than to any one else?

The Washington Humane Society is making a great effort to secure legislation to stop experimentation upon animals even for the advancement of medical science. In this I sincerely hope they will never succeed; but they are alienating from cooperation with the humane societies the great humane forces of the country, viz., the medical and veterinary professions, the biologists, the universities and the Agricultural Department of the Government. In the meantime the value of such experimentation is becoming more and more apparent, and we are slowly learning, by means of it, how to control the destructive diseases affecting mankind and the lower animals. This Bureau has distributed, upon request of the owners of cattle, 500,000 doses of blackleg vaccine during the past year, reducing the loss from about 15 per cent. to 1 per cent. This year we have demonstrated that Texas fever can be prevented without serious restriction to the traffic in Southern cattle, and this discovery will save millions of dollars annually to the people of the Southern and Southwestern States and Territories. We are also introducing a serum treatment for hog cholera which saves 80 per cent. of the animals in diseased herds. These discoveries, made by experimenting upon animals, mean not only many millions of dollars to the country, but they mean the cheapening of the food supply, which is always equivalent to saving human suffering and prolonging human life, and they also mean the prevention of infinite suffering among the species of animals affected by these diseases.

Under these circumstances is it not time for the



liberal and intelligent members of the American Humane Association, who joined that organization to prevent cruelty to animals rather than to secure personal notoriety, to stop and consider whether they are called upon to further support and encourage those narrow-minded and intolerant people whose efforts are a hindrance rather than an aid to the cause of humanity.

Assuring you again of my appreciation of your invitation, and of my sympathy with every intelligent effort for lessening the great sum of misery and suffering to which both our own race and the lower animals are subject, I am, etc.

THE SEVENTH INTERNATIONAL GEOGRAPHICAL CONGRESS.

It will be remembered that at the Sixth International Geographical Congress held in London in 1895 two invitations were presented for the next meeting, one from the United States and one from Germany. The latter invitation was accepted, and the Geographical Society of Berlin, which is assisted by a General German Council, undertook to carry out the necessary preparations. The London *Times* states that invitations are now being issued to the friends and promoters of geography in all countries, and especially to the members of all geographical societies and cognate scientific bodies. The meeting of the Congress will take place from Thursday, September 28, to Wednesday, October 4, 1899. Before the beginning and after the close of the Congress excursions will be arranged through such parts of Germany as may be of interest with regard to physical or economic geography. The Geographical Society of Hamburg will issue invitations for a visit to that city under the auspices and with the sanction of the Senate. Further information respecting the organization and the general program of the Congress will be issued as early as possible.

The subjects which may be treated or discussed at the Congress are embraced in the following groups: (1) Mathematical Geography, Geodesy, Cartography, Geophysics; (2) Physical Geography, Geomorphology, Oceanography, Climatology; (3) Biological Geography; (4) Industrial and Commercial Geography; (5) Ethnology; (6) Local Geography, Exploring Travels; (7) History of Geography and of Cartography; (8) Methodology, School Geography,

Bibliography, Orthography of Geographical Names. It is probable also that some step may be taken to render the work of the Congress more continuous and permanent. Something was done in this direction at the London meeting, but, as the committee of the Congress have no funds at their disposal, it is difficult to carry out any practical work. Some attempt may, therefore, be made to institute a fund out of which grants may be made for special purposes, as is done by the British Association.

The subscription for membership is £1 for either ladies or gentlemen. Members will receive all publications of the Congress free of charge. Ladies accompanying members are also admitted as associates on payment of 10s. All who wish to contribute communications to the Congress are requested to give notice before April 1, 1899, and to send their manuscripts to print not later than June 1, 1899. The time allowed for each discourse or paper will, as a rule, not exceed twenty minutes, but exceptions may be made in the case of subjects of general interest or importance.

According to custom, the English, French, German and Italian languages are admitted as languages of the Congress, and all papers must be written in one of them. All propositions, applications, notifications and manuscripts of papers which are addressed in due time to the Congress will be submitted for examination to a special committee, and, if found suitable, incorporated in the general program, so far as the time at disposal shall allow. If it is desired that full notice of any communication thus admitted be given in the daily bulletin which is to be published during the meeting, an abstract of it, not exceeding 1,500 words, must be delivered before August 1st. Any motion to be laid before the Congress must be formulated in writing, and should be transmitted not later than June 1, 1899. All correspondence relating to matters of the Congress is to be addressed 'To the Seventh International Geographical Congress, 90, Zimmerstrasse, Berlin, S. W.'

STATE OWNERSHIP OF THE TELEGRAPH AND THE TELEPHONE.

THE presidential address given by Mr. W. H. Preece, C.B., F. R. S., before the British Insti-

tution of Civil Engineers, on November 1st, is of such interest that we regret that limits of space do not permit its publication in full. The government of the United States must soon face the problem of the control of the telegraph and telephone, and the account given by Mr. Preece of the condition of affairs in Great Britain may be quoted. He says: "I was sent, in 1877, together with Sir Henry Fischer, to investigate the telegraph system of the American continent, and especially to inquire into the accuracy of the incredible report that a young Scotchman named Bell had succeeded in transmitting the human voice along wires to great distances by electricity. I returned from the States with the first pair of practical instruments that reached this country. They differed but little from the instrument that is used to-day to receive the sounds. The receiver, the part of the telephone that converts the energy of electric currents into sounds that reproduce speech, sprang nearly perfect in all its beauty and startling effect from the hands of Graham Bell. But the transmitting portion, that part which transforms the energy of the human voice into electric currents, has constantly been improved since Edison and Hughes showed us how to use the varying resistance of carbon in a loose condition, subject to change of pressure and of motion under the influence of sonorous vibrations. The third portion, the circuit, is that to the improvement of which I have devoted my special attention. Speech is now practically possible between any two postoffices in the United Kingdom. We can also speak between many important towns in England and France. It is theoretically possible to talk with every capital in Europe, and we are now considering the submersion of special telephone cables to Belgium, Holland and Germany. The progress of the use of the telephone in Great Britain has been checked by financial complications. It fell into the hands of the company promoter. It has remained the shuttlecock of the Stock Exchange. It is the function of the Postmaster-General to work for the public every system of inter-communication of thought which affects the interests of the whole nation. Telephony is an Imperial business, like the Post and the

Telegraph. It ought to be in the hands of the State. \* \* \* Two causes exist to impede this desirable absorption, the fear of being 'done' by watered and inflated capital, and the assumed bad bargain made in absorbing the telegraphs in 1869. The former is a mere bugbear. The public does not want to purchase stock. It wants to acquire a plant and business, which can be easily and fairly valued. The latter is a gross fallacy. The business of the telegraph companies—practically an unlimited monopoly—was purchased on absolutely fair terms, viz.: 20 years' purchase of the net profits. The sum paid was £4,989,048. The number of messages then sent in one year was about 5,000,000, and the gross income about £500,000. The income has now grown to £3,071,723, the number of messages has reached 83,029,999, and the capital account which was closed in 1891, viz.: £10,131,129, including the cost of the Post Office extensions, remained the same. If a syndicate desired now to re-purchase the business and acquire the plant they would have to find a capital of over £30,000,000. In what respect, then, was the transfer of the telegraphs to the State a failure? Our magnificent system has been built virtually out of revenue; our tariff is very cheap; scarcely a village of any consequence is without its telegraph; our press is virtually subsidized by having its news supplied at much less than cost price; we can rely upon safe and accurate delivery and upon speedy despatch of messages. We lead the world. There has been no failure and there was no bad bargain.

#### GENERAL.

LORD LISTER, President of the Royal Society, has addressed an official letter to the Paris Academy of Sciences, asking its opinion as to the advisability of forming an International Scientific Association, representing the chief scientific academies and societies of the world. The Paris Academy has decided to discuss this question in a secret session.

PRESIDENT PUTNAM has called a meeting of the Council of the American Association for the Advancement of Science, on Tuesday, December

27th, at 4 p. m., in Schermerhorn Hall, Columbia University, New York City.

THE Dutch Academy of Sciences has elected the following foreign members: Professor E. C. Pickering, Harvard University; Professor W. C. Röntgen, Würzburg; M. L. V. Delisle, Paris, and Professor F. E. Thorpe, London.

THE French Academy has elected as correspondent in the section of mineralogy M. Deperret, who has been for many years professor at Lyons, and is the author of numerous contributions to geology and paleontology. The other nominees were M. M. Gonnard, O'Ehlerlert and Péron.

PROFESSOR A. S. PACKARD has been given leave of absence from Brown University, and will spend nine months in a trip to Egypt, Palestine and the countries on the Mediterranean.

PROFESSOR JOSIAH ROYCE, of Harvard University, leaves New York on December 20th for Aberdeen, where he will give the Gifford Lectures on 'Natural Religion.' He will return to America in February.

PROFESSOR A. H. CHURCH has been elected President of the Mineralogical Society, London.

PROFESSOR KOCH, who, as we have already stated, has been spending several months investigating malaria at Rome, now proposes to return to Africa to continue his studies on the subject.

THE anniversary meeting of the Royal Society was held on November 30th, and the annual dinner on the evening of the same day. Officers were elected and medals conferred in accordance with the arrangements that we have already announced. Lord Lister referred to the Fellows of the Society who had died during the year, of which there were sixteen, and described the advance of science more especially as related to the activities of the Society. At the dinner in the evening, speeches were made by the Lord Chancellor, the Bishop of London, Lord Lister, Professor Oliver Lodge, Lord Curzon and Lord Kitchener.

THE U. S. Fish Commission steamer *Fish Hawk* is expected to leave Norfolk this week for Porto Rico, where it will remain during the

winter. The party it carries will make a careful study of the various forms of life in the waters about the island, and incidentally the fauna and flora of the land will be studied and collections made in various branches of natural history. On the return of the steamer the material gathered will be submitted to specialists, and their united papers will form a comprehensive report on the natural history of the island. The presence of Mr. A. H. Baldwin as artist to the expedition ensures good illustrations and will make it possible to obtain figures of many marine animals colored from life. Professor B. W. Evermann is in charge, and he will be assisted on the part of the Fish Commission by Mr. H. F. Moore, E. C. Marsh and others. Entomology will be cared for by Mr. August Brusck, of the Department of Agriculture, while Mr. A. B. Baker will represent the National Zoological Park.

THE authorities of the American Museum of Natural History have consented to open the Museum to members of the scientific societies visiting New York on Tuesday, December 27th, although ordinarily the Museum is closed on Tuesdays. On presenting a card to any of the curators, the visitor will be personally shown the objects that may specially interest him.

THOMAS SANDERSON BULMER, M.D., C.M., F.S.A., died by suicide, at Sierra Blanca, Texas, on October 5th. He has pursued amateur researches in American archaeology and ethnology for several years; he made contributions of some note to Pilling's bibliographies of Indian linguistics; during the past year he made journeys through northern Mexico, visiting ruins and collecting information concerning Indian tribes.

DR. EWALD GEISSLER, professor of chemistry in the Veterinary School at Dresden, died on October 15th, aged fifty years.

MR. EDWIN DUNKIN, F.R.S., the distinguished astronomer, died on the 26th inst. in Kidbrooke-park-road, Blackheath. The *London Times* states that he was the third son of Mr. William Dunkin, of the 'Nautical Almanac' office, and was born at Truro in 1821. After being educated partly in England and



partly in France, he joined the staff of the Royal Observatory at Greenwich in 1838, and remained there for 46 years, being promoted successively to be First-class Assistant and Chief Assistant. During this period he represented the Astronomer Royal in several important expeditions, notably the observations of the total solar eclipse at Christiania in July, 1851, and the determination of the telegraphic differences of longitude between the Royal Observatory and the observatories in Brussels, Paris and Valencia, in Ireland. Mr. Dunkin had the sole charge of the Astronomer Royal's pendulum experiments, undertaken to determine the mean density of the earth, at the Harton coal-pit, near South Shields, in 1854. Elected a Fellow of the Royal Astronomical Society in 1854, he served as Honorary Secretary from 1871 to 1877, and in 1884 he was chosen President. He was elected a Fellow of the Royal Society in 1876, and from 1879 to 1881 was a member of the Council of the Society. Mr. Dunkin published a number of works on astronomy, including 'On the Probable Error of Transit Observations,' 'The Midnight Sky,' 'Familiar Notes on the Stars and Planets,' 'Obituary Notices of Astronomers,' and a work on the movement of the solar system in space determined from the proper motions of 1,167 stars. In addition he contributed from time to time to various scientific and other periodicals.

We take also from the London *Times* the following particulars in regard to the work of Professor George James Allman, whose death we were compelled to record last week: He devoted the greater part of his life to investigating the lower organisms of the animal kingdom. For his researches in this branch of biology he received in 1872 the Brisbane prize from the Royal Society of Edinburgh; in the following year a Royal medal was awarded to him by the Royal Society of London, and in 1878 he received the Cunningham gold medal from the Royal Irish Academy. He was appointed by the government in 1876 one of the Commissioners to inquire into the condition of the Queen's Colleges in Ireland, and soon after his election to his professorship in Edinburgh he was appointed one of the Commissioners of Scottish Fisheries. The latter post he held

until the abolition of the Board in 1881. When Mr. Bentham resigned the presidency of the Linnæan Society Professor Allman was elected, and he retained the position until 1883, when he resigned in favor of Sir John Lubbock. He was President of the British Association for the Advancement of Science in 1879. The large collection of Hydroids made during the exploring voyage of the Challenger was assigned to Professor Allman for determination and description. He had previously dealt in a similar manner with the Hydroids collected during the exploration of the Gulf Stream by the United States government. Professor Allman has served on the Councils of the Royal Societies of London and Edinburgh, and of the Royal Irish Academy, and has filled the post of Examiner in Natural History for the Queen's University of Ireland, the University of London, the Army and Navy and Indian Medical Services, and for the Indian Civil Service. He has published the results of his original investigations in the *Philosophical Transactions*, the *Transactions of the Royal Society of Edinburgh*, of the Royal Irish Academy, and of the Linnæan and Zoological Societies of London. Other of his original contributions took the form of reports to the British Association, to the Museum of Comparative Zoology, Harvard University, and to the Commission of the Challenger Exploration, and of communications to the *Annals of Natural History*, the *Quarterly Journal of Microscopic Science* and other scientific publications. His larger works were: 'A Monograph of the Fresh-water Polyzoa,' 1856, and 'A Monograph of the Gymnoblasic Hydroids,' 1871-72, both published by the Ray Society.

MR. C. B. CRAMPTON has been appointed Assistant Keeper in the Geological Department of the Manchester Museum.

DR. KARL FREIHERR VON TUBEUF, Privatdocent at Munich, has been called to the newly established Division for Agriculture and Forestry in the Royal Department of Health, Berlin.

THE Alvarenga prize of the Philadelphia College of Physicians, of the value of about \$180, has been awarded to Dr. S. A. Knopf, of New York City, for an essay on pulmonary tuberculosis.

M. BISCHOFFSHEIM has undertaken to construct and endow an observatory to be placed on Monte Cinto, in the Island of Corsica. Surveys are at present being made, with a view to finding the most suitable site for the observatory.

M. CHAUCHARD, who gives annually large sums for public purposes, has this year set aside 130,000 fr. for various Paris institutions and charities, 10,000 fr. being for the Pasteur Institute.

THE late William E. Hale, of Chicago, has bequeathed \$300,000, to be held in trust, the income to be used for public purposes at the discretion of the trustees.

MR. T. B. BLACKSTONE, of Chicago, who gave more than \$500,000 for the erection and endowment of a library at Brandford, Conn., has now added \$100,000 to its endowment.

A BIOLOGICAL station has been established on Lake Bologoy by the Society of Naturalists of St. Petersburg.

A GRANT of £25 from the Craven University Fund, Cambridge University, has been awarded for the purpose of assisting George B. Grundy, M.A., Brasenose College, to complete surveys and explorations, mainly in northern Greece.

*Natural Science* states that Mr. Alan Owston, of Yokohama, has recently sent to England a magnificent collection of hexactinellid sponges from the seas of Japan. Most of these have been purchased by the Trustees of the British Museum, but a fair number have gone to Oxford. Among the specimens are many studied by Professor Ijima for the monograph that he is writing on the group.

AN expedition has been sent from France to explore the upper course of the Cavally River, which separates the Republic of Liberia from the French possessions. The French government is also about to send a hydrographic expedition to make surveys of the coast of Madagascar.

PROFESSOR McMURRICH, of the department of anatomy of the University of Michigan, has recently been asked by the authorities of the Bremen Museum to investigate a collection of actinia, commonly known as animal flowers or

sea-anemones, obtained from the south Pacific islands. This offer he was regretfully compelled to decline, as he is at the present time engaged in the study of a similar collection from the coast of Chili, made by the authorities of the Royal Museum of Natural Sciences of Berlin.

THE committee of the Royal Society appointed to investigate the Tsetze-fly disease, consisting of Professor Kantback, Mr. H. E. Durham and Mr. W. H. Blandford, have made a report showing that the parasite is capable of infecting a larger variety of animals than was previously supposed, and giving some details in regard to methods of infection, but they have not been able to discover a preventative or cure.

THE arrangements for providing a school of tropical medicine at the branch hospital of the Seaman's Hospital Society, Victoria and Albert Dock, London, E., are, says the *British Medical Journal*, making satisfactory progress. A sub-committee, consisting of Mr. Nairne, Chairman; Sir C. Gage Brown, K.C.M.G.; Mr. Macnamara, Dr. Lauder Brunton, Dr. Stephen Mackenzie, Dr. Manson, Dr. James L. Maxwell, Mr. Johnson Smith, F.R.C.S.; Mr. William Turner, F.R.C.S., and Mr. James Cantlie, F.R.C.S., is now engaged in drawing up a constitution for the school and defining the curriculum. The new buildings will, it is expected, be completed by October 1, 1899, and it is announced that Mr. Chamberlain intends to preside at a festival dinner to be held during the coming Parliamentary session. A valuable collection of paintings of skin diseases and ulcers, common in British Guiana, has been presented to the school by Dr. D. Palmer Ross.

A CORRESPONDENT of the London *Times* telegraphs from Bombay that the hearing of evidence before the Plague Commissioners began on November 29th. The first witness was Mr. A. Wingate, Acting Chief Secretary. He gave a history of the plague in the Bombay Presidency. Segregation in the small towns had destroyed the plague, but it was impossible in the big towns on account of the requirements of trade, though it had been advantageous in certain wards of some towns. The shortest time during which evacuation of villages had been

enforced was three weeks, and the longest three months. Dr. Haffkine was next examined. He described the constituents of his plague prophylactic, the method of its application, and the general result. After the sittings at Bombay the Commission will proceed to Calcutta, which will be reached about Christmas. Having taken evidence in the Northwestern Provinces and the Punjab as to the outbreaks, the Commissioners will visit Sind, ultimately returning to the Bombay Presidency, where the proceedings are likely to be protracted, as this has been the principal seat of the epidemic.

PRESIDENT MCKINLEY's message to Congress contains almost no reference to the scientific work under the government. It is said in regard to forest reservations that at the close of the year thirty forest reservations, not including those of the Afognac forest and the fish-culture reserve in Alaska, had been created by Executive proclamations under Section 24 of the Act of March 3, 1891, embracing an estimated area of 40,719,474 acres. The Department of the Interior has inaugurated a forest system, made possible by the Act of July, 1893, for a graded force of officers in control of the reserves. This system has only been in full operation since August, but good results have already been secured in many sections. The reports received indicate that the system of patrol has not only prevented destructive fires from gaining headway, but has diminished the number of fires.

DR. ERWIN F. SMITH, of the Department of Agriculture, has been investigating the peach orchards of southwestern Michigan which are suffering from a damaging disease known as 'little peach.' The symptoms of the disease are: (1) dwarfing of the fruit; (2) retarded ripening of the fruit, or at least absence of any premature ripening; (3) absence of any red spotting of skin or flesh; (4) dwarfing or yellowing of the foliage from start; (5) absence of the sprouting winter buds. Dr. Smith concludes that the disease is due to a shutting-off of the water supply, but whether this is brought about by some parasite, or by droughts combined with overbearing and with unsatisfactory soil or subsoil

conditions, can only be determined by long and careful study.

MR. FREDERICK W. CHRISTIAN, after an absence of nearly nine years, has recently returned from his explorations in the Caroline Islands. We learn from the London *Times* that Mr. Christian stayed nearly three years in Samoa, studying the language and customs of the peoples, especially those who are farthest removed from the settlements of the white man. In Tahiti and the Marquesas he spent two years, carefully and minutely studying and noting down the language, the genealogies, folklore and traditions of the inhabitants. He visited single-handed Spanish Micronesia, in order to obtain some further and minuter information upon certain mysterious ruins reported to exist upon Bonate, or Ponape, and Lele, two islands lying farther to the eastward of the extensive Caroline chain. The results of Mr. Christian's explorations were as follows: A Pampanga native, since executed by the Spanish for joining the late Philippine rebellion, took some 150 photographs in the districts of Kiti, U, Metalanim, Not and Chokach (wrongly styled Jekoits and Jokoits in the present charts). The walled islets of Nan-Matal, the mysterious Venice of Micronesia, were explored and mapped out fairly accurately. The phoenisis of very many native names and their spelling were changed from a meaningless jargon to their correct native renderings and accompanying significations. He also made excavations in the central vault of the sanctuary of Nan-Tanach, bringing to light a considerable number of curious tools, implements and shell ornaments of an ancient date. Many of the old native legends and fairy tales were rescued from oblivion. Some new information was obtained about the flora and marine life of the archipelago. The former presence of an early Negrito race, conquered and absorbed or overlapped by later waves of Polynesian, Malayan and Melanesian immigrants was fairly established. Also evidence was collected as to the obtrusion of many Japanese words upon the Micronesian area. This was elaborately demonstrated by an exhaustive list of 450 English keywords--nouns, verbs and adjectives--in the various Micronesian dialects. Mr. Christian



spent some three months upon Yap, in the western Carolines. Some of the ancient platforms and burial places—of a Japanese design—and the remarkable village council lodges were sketched. After putting the results of his work on record through the Royal Geographical Society and otherwise, Mr. Christian intends to revisit the Carolines and Mariannes, taking particular notice of Ruk, Tinian, Saipan, Pulawat and Nuku-Oro and the Pelew Islands.

CONSUL MAYER writes to the Department of State from Buenos Ayres, under date of October 12, 1898: The locust advices are not reassuring, as, though the extinction goes on briskly, the invasions are tremendous, and it is apprehended that they will soon be in the Province of Buenos Ayres. Entre Rios and parts of Santa Fé and Cordoba are overrun. In the first three days of October 398 tons of locusts were gathered in Entre Rios alone; but the sub-commissions complain that in some quarters the inhabitants refuse to work at the extinction, and that the police does not lend its authority to compel them. The central commission has issued a circular urging that prompt notice be given of all desoves (egg despositing) and samples sent in, with dates and all other particulars pertinent. The news from Paraguay is that the locusts are thick there and doing wholesale damage. In the colonies south of Santa Fé there have been no invasions as yet, and the farmers are of the opinion that if they escape until the 15th instant both wheat and linseed will be safe. The Jewish colonies in Villaguay have been invaded and the crops destroyed. The colonization company owns 70,000 hectares there, of which 25,000 to 30,000 are under cultivation; so that the great loss to the farmers can easily be imagined, should the crops not come on again. For this, rain is absolutely necessary. The farmers made no move whatever to cope with the plague, and the sub-commission recommends the head commission to be inexorable in imposing fines. The work of extinction is being briskly pushed in other Provinces and is giving good results. Buenos Ayres has not suffered yet, but the plague is coming down apace.

DR. GEORGE F. BECKER has sent to the U.

S. Geological Survey a report on the mineral resources of the Philippine Islands, in the course of which he says that, so far as is definitely known, the coal of the Philippine Islands is all of the Tertiary age, and might better be characterized as a highly carbonized lignite. It is analogous to the Japanese coal and that of Washington, but not to the Welsh or Pennsylvania coals. Such lignites usually contain much combined water (8 to 18 per cent.) and bear transportation ill. They are also apt to contain much sulphur, as iron pyrites, rendering them subject to spontaneous combustion and injurious to boiler plates. In these islands it would appear that the native coal might supplant English or Australian coal for most purposes. Lignite is widely distributed in the archipelago; some of the seams are of excellent width and the quality of certain of them is high for fuel in this class. Coal exists in various provinces of the Island of Luzon, and a number of concessions for mining have been granted. Many of the other islands contain coal and in the great Island of Mindanao it is known to occur at eight different localities. In the Island of Cebu petroleum has been found associated with coal at Toledo, on the west coast, where a concession has been granted. It is also reported from Asturias, to the north of Toledo on the same coast, and from Alegria to the south. Natural gas is said to exist in the Cebu coal fields. On Panay, too, oil is reported at Janinay, in the province of Iloilo, and gas is reported from the same island. Petroleum highly charged with paraffin is also found on Leyte at a point about four miles from Villaba, a town on the west coast. Gold is found at a vast number of localities in the archipelago, from northern Luzon to central Mindanao. In most cases the gold is detrital, and is found either in existing water courses or in stream deposits now deserted by the current. Copper ores are reported from a great number of localities in the Philippines. They are said to occur in the following islands: Luzon (provinces of Lepanto, Benguet and Camarines), Mindora, Capul, Masbate, Panay (province of Antique) and Mindanao (province of Surigao). Many of these occurrences are probably unimportant. A lead mine has been partially devel-

oped near the town of Cebu, and there is iron ore in abundance in Luzon, Caraballo, Cebu, Panay and doubtless in other islands. Sulphur deposits abound about active and extinct volcanoes in the Philippines.

#### UNIVERSITY AND EDUCATIONAL NEWS.

THE fund being collected by the New York Chamber of Commerce as a memorial to the late Colonel Waring, which it is hoped will reach \$100,000, three-fourths of this sum having now been given, is to be used, after the death of Mrs. Waring and her daughter, for the endowment of a chair of instruction in municipal affairs in Columbia University.

MR. E. D. MORGAN has given \$5,000 for the equipment of a pathological laboratory at the Bussey Institute, Harvard University, of which Professor Theobald Smith is the Director. A new greenhouse, costing \$7000, has been given anonymously to the Botanical Garden of the University.

WE regret to note that the will of the late Colonel Bennett, which gave a large endowment to the women's department of the University of Pennsylvania, is being contested.

It is perhaps not generally known that Cornell University possesses the largest school of naval architecture in America. There are this year fifty students taking naval architecture and marine engineering as their chief subjects.

AT the anniversary dinner of the Royal Society on November 31st Lord Kitchener announced that he had received £40,000 for the foundation of a college at Khartoum. As a further indication of what Great Britain is doing for its imperial subjects we note that plans are being made to establish a Mohammedan University in India.

DR. M. E. WADSWORTH has resigned the Presidency of the Michigan College of Mines. In his letter of resignation he says: "When I came to take charge of this institution it had no hold anywhere and its death was hourly expected. I leave it with you firmly established, a recognized part of the great educational system of the State, a college that ranks

with any in the world of its kind, and with many of its graduates leaders in their chosen field. It is now successful, prosperous and of world-wide fame. No mining engineering school in United States ever had such a phenomenal growth in numbers and standing as this one has had in the same space of time, and that, too, under extremely disadvantageous circumstances."

THE *Experiment Station Record* announces the following appointments: At the Idaho College and Station, J. P. Blanton has been appointed President of the University of Idaho and Director of the Station; M. T. French, professor of agriculture in the College and Agriculturist of the Station; Thorn Smith, Assistant Chemist; Professor A. S. Miller, Geologist, and J. A. Huntley has been elected to the newly established chair of horticulture. Elmer D. Ball has been made Assistant Entomologist at the Colorado Station, and A. H. Bryan and R. W. Clothier Assistant Chemists at the Indiana and Kansas Stations, respectively. Charles W. Burkett has been appointed associate professor of agriculture at the New Hampshire College and Station, and James Withycombe Assistant Director and Agriculturist of the Oregon Station. A. W. Blair has been made State Chemist of North Carolina. At the Vermont Station, L. R. Jones and F. A. Waugh have been granted a half year's leave of absence for special studies in botany and horticulture.

THE Council of the University of Paris has authorized courses under the faculty of science by M. Chabrie in applied chemistry, and by M. Favre in methods of experimental science.

THE following appointments and promotions abroad are announced: Dr. Heinrich Obersteiner, assistant professor of physiology and pathology of the central nervous system in the University of Vienna, has been promoted to a full professorship; Dr. Robert Haussner, of Giessen, to an assistant professorship of mathematics, and Dr. K. W. Zimmermann, of Bern, to an associate professorship of anatomy. Dr. Lepetet has been made professor of histology in the University of Clermont, Dr. Oskar Zoth professor of physiology in the University of Gatz, Dr. de Marignac professor of hygiene in the

University of Geneva, and Dr. Hettner, of Tübingen, professor of geography in the University of Würzburg. Professor von Frey, of Leipzig, has received a call to Zurich, and Professor W. C. Röntgen, of Würzburg, a call to Leipzig.

#### DISCUSSION AND CORRESPONDENCE.

##### ZOOLOGICAL BIBLIOGRAPHY AND PUBLICATION.

TO THE EDITOR OF SCIENCE: Any criticisms from Dr. W. H. Dall on the Report of the British Association Committee on the above subject are most welcome, and we look forward to receiving his remarks on the several other details to which he implies that exception may be taken. Meanwhile permit me to point out that his criticism of recommendation (not 'rule') 3 is based on several misapprehensions. Dr. Dall speaks for 'the working zoologists,' but, as stated in our Report, those are just the people that an extensive correspondence showed to be in favor of our recommendation. But, whether warranted or unwarranted, our Report neither contains nor rests on any "assumption that the publication of the separate papers of a volume before the volume as a whole is issued is 'improper,' while the indefinite delay of their publication is 'proper.'" On the contrary, the Report makes precisely the same suggestions concerning date as does Dr. Dall (see recommendation 1), and we fully agree as to the advisability of publishing papers promptly and as to the value of separate copies.

Now, what is our recommendation 3? No one would imagine from Dr. Dall's letter that it was this: "That authors' separate copies should not be distributed privately before the paper has been published in the regular manner." The Committee refuses to consider that an author's distribution of a few copies of his paper to a few friends, or to a few workers whose addresses he happens to know, can rank as 'publication.' In the opinion of the Committee, the terms 'public' and 'private' are opposites and not synonyms. The publications of the Philadelphia Academy, the Washington Societies and the U. S. National Museum are not in question. What the Committee had chiefly to consider (as plainly stated in the Re-

port) was the case of smaller publishing bodies, unable, through lack of funds, to follow those admirable examples. Such smaller bodies often allow their contributors to distribute privately a few copies of their individual papers. This private distribution may take place two or three years before the actual publication of the volume or part, and often is confined to the casual presentation of half a dozen copies. Say the paper describes new species of molluscs. How is the worker on molluscs in another country to hear of this paper? How is he to obtain it if he does hear of it? How is he to learn its contents? He cannot be sure that a letter from him will ever reach the author, or that if it does it will meet with any response. Experience teaches otherwise. Meanwhile he himself describes the same species, and his paper is published, is advertised, and is procurable through the ordinary channels by anyone that chooses. And so springs up a fresh crop of nomenclature troubles. How can Dr. Dall, as a working zoologist, regard the former method as a greater convenience than the latter?

Our remedy is simply an attempt to regularize this previous distribution, to insist on its being made 'public' as well as 'private.' If separate copies are to be issued before the volume a certain proportion of them must be made accessible to anyone, not merely to friends of the author, and this fact must be publicly announced. In short, we are trying to bring about the very state of things that Dr. Dall admires, and we trust that when he perceives this he will give us his influential support.

Your readers may be interested to know that our Committee has been strengthened by the addition of Mr. B. Daydon Jackson and Mr. A. C. Seward, and now proposes to extend its labors to *botanical* publications. Any criticisms or suggestions on the subjects within the cognizance of the Committee will be gratefully received, and I shall be pleased to send its circulars to those interested. Communications should be addressed to

F. A. BATHER,

*Secretary of the British Association Committee  
on Zoological and Botanical Publications.*

NATURAL HISTORY MUSEUM,  
LONDON, S. W.



## MEN OF SCIENCE AND THE HUMANE SOCIETY.

AS to the note in SCIENCE (Nov. 25, 1898, p. 743) urging 'Men of Science and Physicians' to write to Senators of the United States in opposition to a bill introduced to Congress by the Humane Society for the restriction of vivisection, we ought to hope that the advice may not be followed, without an investigation of the merits of the case, on the part of the scientific men who have hitherto accepted, without question, the dicta of their medical, physiological and biological friends on the subject. That a great many scientific workers know as little about the charges of 'wanton cruelty,' 'moral degradation,' and unrestricted abuse of experiment alleged by the anti-vivisectionists as the general public there can be no doubt. The necessary knowledge is out of their line of work and observation, and about the only public information on the subject that comes in the way of a busy man is presented in the tracts gratuitously presented and the bulletins and journals published by, for example, the American and Illinois Anti-vivisection Societies, 118 S. 17th St., Philadelphia, and 275 East 42d St., Chicago; the National Anti-vivisection Society of England, 20 Victoria St., London, S. W.; the Humane Education Committee, 61 Westminster St., Providence, R. I.; the Humane Societies and Societies for the Prevention of Cruelty to Animals of Boston, New York (10 East 22d St.), Philadelphia, etc.; the Audubon Society of Pennsylvania and various States publishing and disseminating *Our Fellow Creatures* (Chicago), *Journal of Zoophily* (Philadelphia), *Our Animal Friends* (New York), *The Zoophilist* (London), etc., and abundant tracts and pamphlets. Not unfrequently these materials, under prejudice at the start, stocking the mails together with a mass of modern second- and third-class postal matter, go generally unexamined into the waste-paper basket.

The quoted writer in SCIENCE, however, would assume that the question against the Humane Societies and opponents of painful experiments on living animals was fully settled in the minds of scientific workers in general, and it would appear from the unanimous vote (in the absence of the writer) against the agitation, at a recent meeting of the American Associa-

tion for the Advancement of Science, that he is right. Yet we believe that not one voter in twenty at the above meeting was qualified to vote, or, if challenged, would have said that he had given the question scientifically just consideration on its merits, either from having studied the nature and rights of animal life or from having investigated the experiments or experimenters as accused by the Humane Societies.

Our colleagues, we might as well admit it, are not exempted by their vocation from the weakness of Adam, and we know that those among them whose minds cannot always be said to be 'open,' too often, by superior activity, 'push,' etc., get the upper hand of meetings where 'resolutions' pass with little or no discussion. However this may have been at the above conference, we stand against the idea of the whole class room turning aside in an alleged important case, fit for their investigating specialty, to follow the advice or unquestioned ipse-dixit of a subdivision of their colleagues.

On the other hand, it seems that it might be commended to us as a phenomenon for wonder and psychic research that any man, by means of gratuitous work, worryment and sleepless nights, in order to limit his own food supply, restrict his range of clothes and adornment and prevent the doctor from curing his own pain, should work for the animals at all. To call the members of the Humane Society fanatics is as easy as to have applied that term to Socrates, Galileo, Wilberforce or Wendell Phillips. But without any prejudice in the matter, we think that the humane agitation, founded on the potent principle of sympathy or love for all living creatures, so omnipotent a factor in the management and development of mankind, will go on. By the truth of the fully heard case, Science will either judge or be judged.

H. C. MERCER.

SECTION OF AMERICAN AND PREHISTORIC  
ARCHÆOLOGY, UNIVERSITY OF PENN-  
SYLVANIA, November 26, 1898.

[MR. MERCER appears to confuse the work of the Societies for the Prevention of Cruelty to Animals with the antics of the anti-vivisection

people. With the former all men of science are in substantial accord; against the latter argument is almost futile. It has been said that as everyone has a blind spot in his eye so everyone has an idiotic spot in his brain. Antivivisection is the idiotic spot of many estimable persons. Regarding the merits of the bill limiting research in the District of Columbia, now pending in the Senate, we cannot do better than refer our readers to a report adopted by the National Academy of Sciences. The report states that physiology must be studied by experimental methods. The physiologist, no less than the physicist and the chemist, can expect the advancement of science only as the result of carefully planned laboratory work. If this work is interfered with, medical science will continue to advance by means of experiment, for no legislation can affect the position of physiology as an experimental science. But there will be this important difference. The experimenters will be medical practitioners and the victims human beings. That animals must suffer and die for the benefit of mankind is a law of nature, from which we cannot escape if we would. But the suffering incidental to biological investigation is trifling in amount and far less than that which is associated with most other uses which man makes of the lower animals for purposes of business or pleasure. The men engaged in the study of physiology are actuated by motives no less humane than those which guide the persons who desire to restrict their actions, while of the value of any given experiment and the amount of suffering which it involves they are, owing to their special training, much better able to judge. When the men to whom the government has entrusted the care of its higher institutions of research shall show themselves incapable of administering them in the interest of science and humanity, then, and not till then, will it be necessary

to invoke the authority of the national legislature.—ED. SCIENCE.]

---

SCIENTIFIC LITERATURE.

*Outlines of Sociology.* By LESTER F. WARD.  
New York, The Macmillan Company. 1898.  
Pp. xii+301.

It is never too late to call the attention of competent readers to a work of the value of Dr. Ward's 'Outlines.' Dr. Ward is one of the few authentic scientists to be met with in the variegated crowd of the so-called 'sociologists.' Every contribution of his deserves, therefore, the most careful consideration.

The book contains twelve papers already published in the *American Journal of Sociology*. It is divided into two parts: (I.) Social Philosophy; (II.) Social Science. By the former Dr. Ward means the study of the relations of Sociology to the other sciences. By the latter he means the study of the laws of society. Hereby Dr. Ward has adopted Professor Robert Flint's view, according to which "each special science and even every special subject may be naturally said to have its philosophy, the philosophy of a subject as distinguished from its science being the view or theory of the relations of the subject to other subjects, and to the known world in general, as distinguished from the view or theory of it as isolated or in itself" (p. viii). We believe this distinction to be entirely misleading. Science means investigation of a well defined group of phenomena. Now, the very act of marking or of ascertaining and setting a limit to the field of inquiry presupposes the discussion of the relationship which the group of phenomena under investigation bears to the other groups of phenomena. Thus, on reflecting well, the task assigned to 'philosophy' by Professor Flint appears to be unavoidably co-extensive with one of the fundamental exigencies of the scientific research. As long as the discussion of the relationship of the subject to other subjects is carried out merely with the purpose of defining the boundaries of the field of inquiry, we do scientific rather than philosophic work. Philosophy begins only when the study of the relationship which one group of

phenomena bears to another is made subservient to the purpose of reaching a synthetical interpretation of the cosmical phenomena, what the Germans would term 'Weltanschauung.' The highest unification of knowledge embodied in a conception of the universal evolution is, indeed, the specific problem of philosophy. There cannot be, therefore, the 'philosophy' of a detached fragment of reality. We have on the one side the sciences, among which is sociology, and on the other side, philosophy, which includes and supersedes them all.

For these reasons we should like to have the designation of 'Social Philosophy' dropped from the first part of Dr. Ward's book, which, from beginning to end, ought to be considered as a contribution to 'Social Science.' This would practically leave the book unchanged, but would have the inestimable advantage of eliminating any possibility of confusion arising from the misleading notion of 'Social Philosophy.'

But, apart from this unhappy denomination, we find the contents of Part I of Dr. Ward's book extremely interesting. He examines in detail the position which Sociology bears to Cosmology, to Biology, to Anthropology, to Psychology and to the special social sciences. The well-known competence of Dr. Ward as a natural scientist gives a particular value to this review of the different groups of phenomena from which social fact is differentiated. In Chapter VI. Dr. Ward discusses the important question of the position which Sociology bears to the special social sciences. Dr. Ward's view is identical to that of Professor Giddings, whose admirable chapter on the 'Province of Sociology,' in his earlier work, has done more than anything else towards the clear demarcation of the place of Sociology among the sciences. According to this theory, Dr. Ward conceives Sociology as the synthesis of the partial results attained through the distinct investigations of the special social sciences. "No one of these (sciences) nor all of them together can be said to form Sociology, but Sociology is the synthesis of them all. It is impossible to perform this synthesis without a clear conception of the elements entering into it. These, therefore, constitute the data for the process. The special

social sciences, then, are not themselves the science of Sociology, but they constitute the data of Sociology" (p. 166).

In the second part of his work, Dr. Ward takes up the discussion of the laws of society. He reproduces his well-known conception of the 'psychic' character of the social forces. The most important chapters are the VIIIth: The Mechanics of Society; the XIth: Social Genesis, and the XIIth: Individual Telesis, in which the fundamental lines of the theory are set forth with great clearness. The root of Dr. Ward's doctrine is the assumption that 'the social forces are psychic.' "They have their seat in the mental constitution of the individual components of society" (p. 164). Dr. Ward does not mean the thinking faculty only, as it is understood by the popular conception of the mind, but both the *affective* side of the mind and the *perceptive*, and rather the former than the latter. Feeling is the true foundation of social life. It is the 'dynamic agent,' that which impels and that which moves, the *nisus* of nature transferred from the physical to the psychic world (p. 167). It exerts its power through the myriad forms of appetitive desire constituting impulses or impelling forces and motives or moving forces, all of which may be embodied under the general term will (p. 175). Social progress is either genetic or telic. Progress below the human plane is altogether genetic and is called development. In the early human stages it is mainly genetic, but begins to be telic. In the latest stages it is chiefly telic. The transition from genetic to telic progress is wholly due and exactly proportional to the development of the intellectual faculty. The intellectual method is essentially telic. The intellect was developed as an aid to the will for the sole purpose of securing the more complete satisfaction of desire. It enables man to obtain by an indirect method what he could not obtain by a direct method (p. 179). The moment we rise to the social sphere we encounter the telic aspect of the subject. It is still development or evolution, but a new principle, radically different from the genetic, has now been introduced, and in all the higher forms of social progress it assumes the leading rôle (p. 179, 180). It is the faculty of mind which enables man to pursue ends which it



foresees and judges to be advantageous (p. 237). The human intellect is the great source of telic activity (p. 245).

We fully endorse this view of social evolution, which is, in the main lines, in accord with the results of the most recent investigations (Tarde, Baldwin, Giddings, Barth, Stein). But we must call attention to the fact that Dr. Ward's suggestive theory of social teleosis cannot acquire a definite meaning if not interpreted in the light of the Imitation-theory. How does invention, *i. e.*, the normal result of telic activity, act upon the social milieu, thus becoming a 'cause' of transformation of the social conditions? In other words, what is the way of propagation of the typical social force, of the dynamic agent, desire, motive, will power? Dr. Ward is silent on this point. Here, evidently, the leading-string is the Imitation-theory, which once more appears to be the corner-stone of sociology.

In conclusion, Dr. Ward's book is a very valuable work, which will undoubtedly contribute to clear the way of the cumbersome remains of the 'biologic' analogies, thus securing the pre-eminence of the psychological interpretation of society, owing to which the shapeless embryo of science, or, rather, the reservoir of 'mauvaise littérature,' known for so long as Sociology, is gradually being changed into a body of knowledge exhibiting some of the characteristic attributes of science.

GUSTAVO TOSTI.

*The Instincts and Habits of the Solitary Wasps.*

By GEO. W. and ELIZABETH G. PECKHAM.

Published by the State of Wisconsin. 1898.

Pp. 245. Pls. xiv.

It is not too much to say that this work will be regarded as a classic, not only on account of its scientific value, but also as literature. It has all the lucidity and charm that we are accustomed to associate with Gallic genius, while at the same time its exactness in detail would do credit to a German professor. It is a book of incalculable educational value, for it not only exhibits the delights of intelligent nature study, but shows what admirable work may still be done, in any garden in the country, by persons of either sex and almost any age beyond childhood. It does not lay stress on laboratories or

apparatus, nor does it demand the outlay of money; those who would follow in the footsteps of our authors have only to exercise those faculties provided them by nature, and, if they have it in them to succeed, success will be theirs.

But let it not be imagined that the work is easy or simple. There is scope for intellectual exercise to the utmost limit, while physical endurance and patience are essential. Think of the mental attitude of some being from Mars who should be placed in a position to observe the doings in a busy city on this earth. How extraordinary, how inexplicable, would some of our most simple and every-day proceedings appear! How wild would be his guesses as to the meaning of this or that! Yet the student of insect psychology is hardly in a more favorable position, and it requires the closest attention and keenest wit to avoid gross errors of judgment. This is well seen in the fact that our present authors have to correct even the accomplished and painstaking Fabre in many of his important conclusions.

Then as to physical endurance; our authors watched their wasps throughout the long hours of the summer days, and sometimes far into the night. When studying *Ammophila* they write: "For a whole week of scorching summer weather we lived in the bean patch, scorning fatigue. We quoted to each other the example of Fabre's daughter Claire, whose determination to solve the problem of *Odynerus* led to a sunstroke. We followed scores of wasps as they hunted; we ran, we threw ourselves upon the ground, we scrambled along on our hands and knees, in desperate endeavors to keep them in view, and yet they escaped us. After we had kept one in sight for an hour or more some sudden flight would carry her far away and all our labor was lost. At last, however, our day came. We were doing a little hunting on our own account, hoping to find some larvæ which we could drop in view of the wasps and thus lead them to display their powers, when we saw an *urnaria* fly up from the ground to the underside of a bean leaf and knock down a small green caterpillar. Breathless with an excitement which will be understood by those who have tasted the joy of such a moment, we hung over the actors in our little

drama. The ground was bare; we were close by and could see every motion distinctly. Nothing more perfect could have been desired." For what followed we can only refer the reader to the book itself, wherein is told even how *Ammophila* used a tool in perfecting her nest.

In the concluding chapter the authors write: "Our study of the activities of wasps has satisfied us that it is impracticable to classify them in any simple way. The old notion that the acts of bees, wasps and ants were all varying forms of instinct is no longer tenable and must give way to a more philosophical view. It would appear to be quite certain that there are not only instinctive acts, but acts of intelligence as well, and a third variety also—acts that are probably due to imitation, although whether much or little intelligence accompanies this imitation is admittedly difficult to determine. Again, acts that are instinctive in one species may be intelligent in another, and we may even assert that there is considerable variation in the amount of intelligence displayed by different individuals of the same species."

The fact of great individual psychological variation is very clearly demonstrated throughout the book; but, since all the observations were made in the same immediate vicinity, it has not been possible to determine whether there exist psychological races among wasps, as among ourselves. It will remain for other observers to repeat the work of the Peckhams in many different localities, and see how far each species is constant over a wide range. There can be little doubt that variations in habits, to suit different environments, are much more common than we know; and it is also evident that psychological and physiological variations, not necessarily accompanied by gross morphological changes, must have a great deal to do with the manner and progress of evolution. Comparative studies in different localities may also explain habits which, studied in one place only, seem useless. Thus the Peckhams cannot explain why *Bembex* is so careful to hide the entrance of her nest, since in the case of the colony studied (on an island) there is apparently no enemy to be guarded against in this manner. It might prove, by studies elsewhere, that this was a device to conceal the nests from noc-

turnal mice or some other enemy of which we know nothing.

T. D. A. COCKERELL.

MESILLA PARK, N. M., November 10, 1898.

*Four-footed Americans and their Kin.* By MABEL OSGOOD WRIGHT. Edited by FRANK M. CHAPMAN. With 73 illustrations by ERNEST SETON THOMPSON. New York, The Macmillan Co. 1898. Pp. 432. Price, \$1.50.

Among the many popular books on natural history that have appeared recently, very few have treated of mammals and none have been devoted exclusively to them. It is, therefore, gratifying to find in 'Four-footed Americans' an attractive, well-illustrated volume containing accounts of common North American mammals—accounts which, though primarily intended for children, must prove interesting and instructive to older persons.

The book is planned after the manner of 'Citizen Bird,'\* by the same author, and is evidently intended as a companion volume. As in 'Citizen Bird,' the descriptions and life histories are presented by interesting characters in the form of stories, which, though not always spiced with adventure, are well calculated to attract young minds and create a wholesome interest in the animals for their own sakes. The spirit of the title is maintained throughout; it is emphatically American—an exceedingly creditable feature. In a household where such a book finds a place children are sure to grow up knowing and loving the animals of their own country.

The book closes with a 'Ladder for climbing the Family Tree of the North American Mammals' (presumably by the editor), which is an abridged and adapted classification, giving a few characters for the larger groups and indicating approximately the number of species of each family. In the few pages devoted to this 'Ladder' errors in typography and nomenclature are not infrequent. Conspicuous among these are the use of *Manatus* instead of *Trichechus*, *Dicotyles* instead of *Tayassu*, *Dorcelaphus* for *Odocoileus* and *Aleces aleces* for *Aleces americanus*. Inaccuracies in the text, also apparently overlooked by the editor, are the statements

\* Reviewed in SCIENCE, November 5, 1897, p. 706.

that *Desmodus* (called *Desmodon*) is no larger than our Little Red Bat and that bats do not migrate. The use of the name Least Shrew for *Sorex personatus* seems ill advised, since there are at least two smaller species and several which do not exceed it in size. Aside from these minor criticisms, there is little but good to be said of the book as a whole. Mr. Thompson's illustrations are numerous and in the majority of cases splendidly executed; that they are well up to his own standard is sufficient commendation.

W. H. OSGOOD.

*A Laboratory Guide in Qualitative Chemical Analysis.* By H. L. WELLS, M.A., Professor of Analytical Chemistry and Metallurgy in the Sheffield School of Yale University. New York, John Wiley & Sons. Pp. 200. \$1.50.

*A Short Course in Inorganic Qualitative Analysis for Engineering Students.* By J. S. C. WELLS, PH.D., Instructor in Analytical Chemistry, Columbia University. New York, John Wiley & Sons.

Both of these books are new, and both are worthy to be picked out from the innumerable laboratory manuals as much above the average.

Professor H. L. Wells' laboratory guide is the most original and one of the best works on the subject, known to the reviewer.

In a 'notice to the student' in the first chapter of the book, the author says: "The object of this course is to introduce the subject of qualitative analysis in such a way as to develop the powers of observation, inductive reasoning and memory, and at the same time to give a knowledge of chemical facts and methods which will be of use in the future study of this and related subjects." The author's method is to have the student make and preserve a solution of a salt of each of the common bases. The student is then told to test the action of hydrochloric acid on each of these solutions; he finds that three yield a precipitate. Five cc. of each of these three is diluted with two volumes of water and again tested with hydrochloric acid; by further dilution and testing with acid, calculating in each case the amount of salt present, the quantitative limit of the reaction is studied. The student then takes in separate beakers a meas-

ured amount of each of the three original solutions, and in a fourth beaker a mixture of the three; all four are precipitated by the acid, filtered, and washed with boiling water. By addition of sulphuric acid to the filtrate from the mixed chlorides a precipitate is formed; by adding sulphuric acid to the filtrate from each of the other chlorides the student finds out which of the three constituents of the mixture caused the precipitation. The action of ammonia on the residues in the filters is then studied, and thus the student works out for himself the common scheme of analysis of the first group.

The other groups are worked out in a similar way; at every step the ingenuity of the author in presenting the problem to the student in the best way is worthy of notice.

The reactions of acids are studied in a similar manner. The book contains no tables, no abbreviated schemes, and everything is done to avoid mechanical work and to lead the student to independent thought. Fresenius' plan of analysis is followed, though various new methods are introduced. Constant references to Fresenius' 'Qualitative Analysis' foster the habit of consulting books of reference.

It is the belief of the reviewer that Professor Wells' method is admirable for students who can devote time enough to the subject, and it is to be hoped that teachers who have classes or single students in this position will give his book a trial.

The book of Dr. J. C. S. Wells, of Columbia, is quite different in character from that of the Yale professor. It is a careful and thorough work, designed for the use of those who can give little time to the subject. It endeavors by exceptionally full and clear descriptive text and tables of scheme reactions to teach qualitative analysis in the least time and with the least labor on the part of the student.

The advantages and disadvantages of the scheme-table system are apparent and have often been discussed. To those teachers who prefer the use of tables Dr. Wells' book can be recommended as one of the best of its kind.

EDWARD RENOUF.

*A Text-Book of Mineralogy.* With an extended Treatise on Crystallography and Physical



Mineralogy. By EDWARD S. DANA, Professor of Physics and Curator of Mineralogy, Yale University. New York, John Wiley & Sons. New Edition. Cloth. 8vo. Pp. viii + 593. Price, \$4.00.

The text-book of mineralogy, first issued by Professor E. S. Dana in 1877, has passed through some 17 editions, each a revision of those preceding, the changes hitherto being either corrections or the insertion of supplementary chapters. The edition just issued is essentially a new work, entirely rewritten and considerably enlarged.

The descriptive mineralogy is an abridgement of the sixth edition of the author's System of Mineralogy and needs no comment.

Nearly one-half of the book is devoted to Crystallography and Physical Mineralogy. In crystallography there are especially to be noted the complete replacement of the formerly used Naumann methods of calculation by those of Miller, and the abandonment of the old conception of hemihedrism. The crystals are described under thirty-two symmetry groups, as in Groth, Liebisch and others, and it is perhaps to be regretted that these groups have been renamed for prominent forms, type minerals, or to suggest terms of hemihedrism.

In Physical Mineralogy the optical characters are discussed in considerable detail upon the undulatory theory, no assumption, however, being made as to the elasticity of the ether in crystals, although for convenience the symbols  $\alpha$ ,  $\beta$ ,  $\gamma$ , formerly denoting axes of elasticity, are retained as so-called 'ether axes.' Very little space is devoted to apparatus or manipulation. It may be noted also that for the determination of the indices of refraction by total reflection, not only the sections cut normal to the acute bisectrix, as stated, but any section parallel to one of the ether axes  $\alpha$ ,  $\beta$  or  $\gamma$  suffices. It may also be questioned if the stauroscopic methods, p. 221, are in any case either as convenient or more accurate than the microscopic.

Cohesion and Elasticity are concisely discussed, but the space devoted to thermal electrical and magnetic characters, about six pages, is regrettably small.

The work is well printed and illustrated with about 1,000 excellent cuts. An admirable point

is the list of selected references at the end of each subject. In every way the work is an improvement upon the last edition.

A. J. M.

---

#### SCIENTIFIC JOURNALS.

THE addresses of Professor George E. Hale, on 'The Functions of Large Telescopes' and of Professor Frank P. Whitman on 'Color Vision,' published in the issues of this JOURNAL for May 13th and September 9th respectively, and the paper by Dr. Charles F. Brush on 'A New Gas,' published on October 14th, have been translated into French and printed as leading articles in recent numbers of the *Revue Scientifique*. Professor E. E. Barnard's address on the 'Development of Astronomical Photography' has been translated into German from the issues of this JOURNAL for September 16th and 23d, and published in the *Naturwissenschaftliche Rundschau* for November 26th and December 2d and 9th.

*Natural Science* will hereafter be published by Mr. Young J. Pentland, 11 Leviot Place, Edinburgh. *Natural Science* has been edited anonymously and this policy will apparently be continued. The current number says: "There will be no change in the policy of the review, no break in continuity, and no lowering of the standard hitherto set before it. But those who wish well to the future of this journal should remember that it lies with them to see that it has a future. Editors cannot edit unless there are contributions of articles, notes and news; publishers cannot publish if every reader reads the copy of a friend or of a library." It may be remarked that publishers and editors are subject to the same conditions in America as in Great Britain.

---

#### SOCIETIES AND ACADEMIES.

NEW YORK ACADEMY OF SCIENCES—SECTION OF BIOLOGY—MEETING OF NOVEMBER 14.

THE resignation of Professor E. B. Wilson was read and accepted by the Section. Professor Frederic S. Lee was unanimously elected Chairman of the Section.

The following program was then presented :

1. H. F. Osborn. On the presence of a Frontal Horn in *Aceratherium incisicum* Kaup.
2. H. F. Osborn. On some additional characters of *Diplodocus*.
3. W. D. Matthew. On some new characters of *Clænodon* and *Oxyæna*.
4. W. E. Ritter. On the Ascidiæ collected by the Columbia University Puget Sound Expedition of 1896. Presented by Dr. Dean.
5. J. P. McMurich. Report on the Hexactinidæ of the same expedition. Presented by Dr. Calkins.

Professor Osborn described the appearance of an hitherto unrecognized frontal horn on the skulls of *Aceratherium incisicum* Kaup ; a discovery of importance, as it practically removes *Aceratherium* from the group to which it gives its name and ranges it with rhinoceroses. Professor Osborn suggested that it may possibly be an ancestor of *Elasmotherium*.

In discussing the paper Dr. Wortman criticised the common tendency to create types based on a single character, citing in support of his suggestion the considerable variations to which single individuals of a species are subject, and giving one or two instances where errors have occurred.

In his second paper Professor Osborn described the structure of the vertebrae of *Diplodocus*, bringing out in considerable detail the variations in the sacrum of the herbivorous Dinosaurs.

Dr. Matthew briefly described the characters of the teeth, manus and pes of *Clænodon*, a form belonging to one of the three families (Arctocyoniidæ) which gave rise to the present-day carnivora. The structure of the wrist bones in particular brings this form almost within the limits of the carnivora, and Dr. Matthew regards it as a primitive bear which lived on fruits, honey or other soft foods. *Oxyæna*, another typical Creodont, was also described by Dr. Matthew, the principal points brought out being the disproportion of the brain case, limbs and lower jaw.

In the discussion which followed, Professor Osborn showed that while *Clænodon* undoubtedly possesses many precocious bear-like structures there are many difficulties to push aside before it can be considered the direct ancestor of the

bear. There are transitional forms, for example, between dogs and bears, as shown in certain types of teeth (*Amphicyon*), while, on the other hand, there is a marked difference in the size of the brain of the Arctocyoniidæ and that of the bears, the brain of the former resembling more closely the brain of the marsupials. If the *Amphicyon* evidence is of a sufficient phylogenetic value the bear line must have arisen much later than Dr. Matthew believes. Dr. Lee also questioned the advisability of ascribing particular functions to specialized structures, a criticism which Dr. Matthew met by saying that in this case the relation of structure to function was in the nature only of an hypothesis, an explanation supplemented by Professor Osborn's statement that in all such cases it is necessary to have some working hypothesis, although each hypothesis is considered merely tentative.

At the request of Dr. Dean, Mr. Richard Weil was asked to give the main results of his observations on the development of the *Ossicula auditus* in the Opossum. Mr. Weil finds that both the malleus and incus are derived from the mandibular arch and have no connection with the hyoidean, thus confirming the older German view.

The other papers on the program presented by Dr. Dean and Dr. Calkins were strictly technical and received only brief mention. They will appear in full in the Annals.

GARY N. CALKINS,  
Secretary.

#### THE PHILOSOPHICAL SOCIETY OF WASHINGTON.

THE 409th meeting of the Society was held at 8 p. m., November 26th, at the Cosmos Club. The first paper of the evening was by E. D. Preston on the International Geodetic Association Conference at Stuttgart from October 3d to October 12th. The 2d was by Dr. Cyrus Adler on an International Catalogue of Scientific Literature. The 3d was by Mr. René de Saussure on the Graphical Determination of Stream Lines. A diagram showing an application of the last paper will be presented at the next meeting.

E. D. PRESTON,  
Secretary.

# SCIENCE

EDITORIAL COMMITTEE: S. NEWCOMB, Mathematics; R. S. WOODWARD, Mechanics; E. C. PICKERING, Astronomy; T. C. MENDENHALL, Physics; R. H. THURSTON, Engineering; IRA REMSEN, Chemistry; J. LE CONTE, Geology; W. M. DAVIS, Physiography; O. C. MARSH, Paleontology; W. K. BROOKS, C. HART MERRIAM, Zoology; S. H. SCUDDER, Entomology; C. E. BESSEY, N. L. BRITTON, Botany; HENRY F. OSBORN, General Biology; C. S. MINOT, Embryology, Histology; H. P. BOWDITCH, Physiology; J. S. BILLINGS, Hygiene; J. MCKEN CATTELL, Psychology; DANIEL G. BRINTON, J. W. POWELL, Anthropology.

FRIDAY, DECEMBER 23, 1898.

ZOOLOGY AND THE PHILOSOPHY OF EVOLUTION.\*

## CONTENTS:

<i>Zoology and the Philosophy of Evolution</i> : PROFESSOR W. K. BROOKS.....	881
<i>Fermentation without Living Cells and Synthetic Proteins</i> : DR. H. W. WILEY.....	893
<i>The 'Feeling of Being Stared At.'</i> PROFESSOR E. B. TITCHENER.....	895
<i>What is Sciurus variegatus Exleben?</i> E. W. NELSON.....	897
<i>Notes on Physics</i> :—	
<i>Transformer Design; Underground Electric Currents in New York City; High-Voltage Power Transmission</i> : W. S. F.....	898
<i>Notes on Inorganic Chemistry</i> : J. L. H.....	899
<i>Current Notes on Anthropology</i> :—	
<i>Russian Ethnography; Argentine Ethnography; The Ethnological Survey of Canada</i> : PROFESSOR D. G. BRINTON.....	901
<i>Scientific Notes and News</i> .....	902
<i>University and Educational News</i> .....	905
<i>Discussion and Correspondence</i> :—	
<i>Antlog or Proton?</i> : PROFESSOR CHARLES SEDGWICK MINOT. <i>Is the Beach Pea Food or Poison?</i> : JOHN MURDOCH.....	906
<i>Scientific Literature</i> :—	
<i>Encyclopaedic der Mathematischen Wissenschaften</i> : PROFESSOR GEORGE BRUCE HALSTED. <i>Darwin on the Tides</i> : R. S. W. GAGE'S <i>Elements of Physics</i> : W. LE CONTE STEVENS. <i>Van't Hoff's Leçons de chimie physique</i> : PROFESSOR HARRY C. JONES. <i>Moore's Laboratory Directions for Beginners in Bacteriology</i> : DR. WM. H. PARK. <i>General</i> .....	907
<i>Scientific Journals</i> .....	916
<i>Scienties and Academies</i> :—	
<i>Entomological Society of Washington</i> : DR. L. O. HOWARD. <i>Biological Society of Washington</i> : F. A. LUCAS. <i>The New York Section of the American Chemical Society</i> : DR. DURAND WOODMAN. <i>Section of Psychology and Anthropology of the New York Academy of Sciences</i> : C. B. BLISS. <i>Students' Club and Geological Conference of Harvard University</i> : J. M. BOUTWELL. <i>The Academy of Science of St. Louis</i> : PROFESSOR WILLIAM TREBLESE.....	917
<i>New Books</i> .....	920

"I have nothing to say to any Philosophy of Evolution. \* \* \* Attempts to construct such a philosophy may be useful, but in my judgment they are premature."—HUXLEY: 'Collected Essays,' V.

The facts given in the last two lectures seem to show that we cannot expect much from the 'Lamarckian factors,' even if they should prove to be factors; and while this impression may be wrong, it seems to be the rational frame of mind until it has proved wrong.

He who follows the current literature of zoology finds that many writers assure him, in effect, that the years which Darwin and Wallace gave to hard labor on the problem of species were thrown away, since all they tried to find out by hard work might have been deduced from the Philosophy of Evolution.

We were warned, long ago, that "whoever, unable to doubt and eager to affirm, shall establish principles, and, according to the unproved truth of these, shall reject or receive others, \* \* \* he shall exchange things for words, reason for insanity, the world for a fable, and shall be incapable of interpreting."

In 'philosophy' current history is sometimes ancient history, and the ardent dis-

\* One of a course of lectures on the Foundations of Zoology as delivered in Columbia University, December, 1898.



ciples of 'philosophers' who, in modest earnestness, undertake to formulate the scientific knowledge of their day often become bolder than their teachers, and, growing arrogant and reckless with success, find at last that they have sold their birthright in nature for what proves, when examined, to be no better than a mess of pottage.

The evidence that living matter is continuous, from beginning to end, is so conclusive that it convinces all who know its value. All living things are one by birth, and the system of living nature is, historically, a unit, a consistent whole—not a collection of isolated and independent species. How does it happen, then, that at every point in its history we find it divided into detached groups, separated by gaps and characterized by fitness? Why is the system of living nature such that we cannot picture it as a circle, spreading in all directions from a common center, and growing wider around its whole circumference? Why is it such that it is more exactly represented by a number of growing radii, independent at their outer ends.

This is the problem which Darwin undertook to solve, by showing that it results from extermination according to a standard of fitness. How does the Lamarckian meet it? Sometimes by denying the existence of fitness. Sometimes by asserting, even in the same breath, that fitness is universal and necessary, and that there is no real problem.

He asserts that it is the outcome or expression of a deeper principle of necessary progress or evolution, which must result in fitness. The tendency to regard natural selection as more or less unnecessary and superfluous, which is so characteristic of our day, seems to grow out of reverence for the all-sufficiency of the philosophy of evolution, and pious belief that the history of living things flows out of this philosophy as a necessary truth or axiom.

"The inheritance of characters acquired

during the life of the individual is an indispensable axiom of the monistic doctrine of evolution."<sup>\*</sup>

The writer yields to no one in admiration of the doctrine of evolution. So far as it is a scientific generalization from our knowledge of nature, it is one of the greatest triumphs of the human mind, rivalled only by its reciprocal, the doctrine of dissolution.

Experience seems to show, very clearly, that our system of nature is, on the whole, moving towards what commends itself to our minds as evolution, or progress to greater and greater perfection. While there is just as much evidence that each step in evolution is also a step toward dissolution, we have the same rational ground for expecting that this movement will continue, without any sudden radical change, that we have for other expectations which we base on knowledge of nature.

So far as the doctrine of evolution is based on knowledge, it is not only a part, but one of the most valuable and suggestive parts of the system of science, for the scientific law of evolution is part of science; but the philosophy of evolution is held by many as a creed, superior to and able to direct science. As men of science, we, like Huxley, have 'nothing to say to any philosophy of evolution,' except so far as it stands in the way of scientific progress.

We are sometimes told that while the other idols of which Bacon warned us are still worshipped, the idols of the theater have been deserted, and their temples abandoned; although he himself lays peculiar stress on their persistency.

"Lastly, there are idols which have crept into men's minds from the various dogmas of particular systems of philosophy, \* \* \* and these we denominate idols of the theater. For we regard all the systems of philosophy hitherto received or imagined as so many plays brought out and performed, creating

\* Haeckel, 'Monism,' p. 96.

fictitious and theatrical worlds. Nor do we speak only of the present systems, or of the the philosophy and sects of the ancients, *since numerous other plays of a similar nature can still be composed.*"

They who worship this modern idol of the theater hold that everything which has taken place and everything which can take place in our universe is deducible from the primal distribution of matter and energy. They tell us that everything in the past and everything in the future follows, of necessity, from this starting-point, inasmuch as it might all have been predicted; but while science knows laws—laws of evolution and others—it knows no necessity except the logical necessity for stopping when evidence stops.

The evolutionist tells us that if we start with a homogeneous universe, with all the matter uniformly distributed, and all the energy kinetic; and if any break in this indefinite unstable homogeneity exist or be brought about, all the rest must follow of necessity, as a matter of course, from the nature of things; that all things must go on along their predetermined course until all the matter shall have fallen into stable equilibrium, and all the energy shall have become latent or potential.

As no one can say the basis for all this is not true, and as it seems much more consistent with scientific knowledge than other systems of philosophy, we must admit that, for all we know to the contrary, it may be true; and we must ask whether, if true, it is any substitute for science; although we must remember that there is no end to the things which, while no one treats them seriously, may nevertheless be true.

All the fancies of the poets which do not involve a contradiction may be true; but while anything which is not absurd may be good poetry, science is founded on the rock of evidence.

Many have found the opinion that all

nature is conscious and endowed with volition, that the morning stars sing together, that the waters laugh, that trees talk, and that the wind bloweth where it listeth, worthy of belief; and it is clear that we cannot oppose any belief of this sort by evidence, or convert the sailor who believes that the wind obeys his whistle, by asking for proof.

The path of scientific progress is strewn with beliefs which have been abandoned for lack of evidence, as burst shells strew a battlefield, and it is our boast that they are abandoned, and not lugged along the line of march. As a shell which has failed to burst is, now and then, picked up on some old battlefield, by some one on whom experience is thrown away, and is exploded by him in the bosom of his approving family, with disastrous results, so one of these abandoned beliefs may be dug up by the head of some intellectual family, to the confusion of those who follow him as their leader.

So far as the philosophy of evolution involves belief that nature is determinate, or due to a *necessary law of universal* progress or evolution, it seems to me to be utterly unsupported by evidence, and totally unscientific.

This system of philosophy teaches that, for purposes of illustration, our universe may be compared to an unstable, homogeneous, saturated solution, which remains unchanged so long as it is undisturbed, but crystallizes when shaken. The process of evolution must be supposed to start with a disturbance or shock. Something, inherent in the nature of things or outside, must press the button; but matter and its properties do all the rest, just as crystallization follows from the properties of the solution. Even if all this is granted, it is not apparent that the mind of the evolutionist has any power by the aid of which it could deduce anything whatever from

homogeneity, even if it were present at the beginning.

There are homogeneous solutions of sugar and homogeneous solutions of brine, and no one without experience of similar facts has any way to tell what potencies are latent in a solution except by finding out. While we find no reason to suppose a homogeneous saturated solution has any power to initiate anything, we cannot think of it as inert. It is, as it were, alive with energy, and its inactivity is due to the exact balancing of all its powers. It is prepared to spring into energetic action the instant the bonds that chain it are broken by something that disturbs the balance and sets its forces free.

So, too, the primæval homogeneity of the evolutionist is imagined as instinct with world-producing energy, ready to evolve stars and systems and worlds and oceans and continents and living things and men, and all that is 'in the round ocean, and the living air, and the blue sky, and in the mind of man,' the instant it is set free; and so on to the end, which will come when all the energy has worked itself out in motion, and all the matter has found rest in stable equilibrium.

Unless he who worships this idol of the theater is prepared to assert that there is only one kind of indefinite incoherent homogeneity, and unless he knows, in some way of which men of science are ignorant, what sort of homogeneous solution our universe was at the beginning, the only way for him to learn what potencies are latent in it is to find out by studying their products. It is hard to see how he can deduce anything whatever from his necessary law of universal progress except what he discovers. If his premises are admitted, all he can deduce from them regarding our subject is that, if he finds natural selection, the potency of natural selection was latent in his solution.

The philosophy of evolution is of no more use as a substitute for science than any other system of philosophy, although it is, no doubt, not only the latest, but the most consistent with our knowledge of nature, and although it may, for all I know to the contrary, be true. All this fails to give it any value as a short cut to natural knowledge.

The true believer may say, however, that while our finite, imperfect minds may be unable to deduce anything from homogeneity, in the absence of knowledge drawn from experience, the outcome of the process must nevertheless be determinate. As it has all come out of the primæval homogeneity, he says this must have contained it all potentially.

I am no philosopher, but this does not seem obvious or necessary to me. Nature, as we know it, consists in the main of permutations and combinations. 'I do not know,' is one thing, and 'I do know not,' is another, even if some fail to discriminate.

"It is easy to perceive that the prodigious variety which appears, both in the works of nature and in the acts of men, and which constitutes the greatest part of the beauty of the universe, is owing to the multitude of different ways in which its several parts are mixed with or placed near each other."

When we say three dice *can* be thrown in only two hundred and sixteen ways, all we mean is that we *cannot* throw them in any other way. We cannot throw three zeroes, or three sevens, in any way with ordinary dice without changing the marks; but we cannot attribute to the dice any latent capacity for being thrown in any way, or any capacity to do anything whatever as dice, even after we have been informed by Haeckel that 'the real maker of the organic world is, in all probability, a tetrahedron.'\*

\* 'Monism,' pp. 27, 28.



Except for a few odd thousands of quintillions of permutations and combinations no others can be formed from twenty-six letters, and if Galileo means any more than this by his remark that all truth is contained in the compass of the alphabet; if his words are more than figurative; if he intends to assert that the potency of literature is latent in the alphabet, independently of an author—it seems to me, with all respect for Galileo, that he is talking nonsense; for while the production of a learned treatise by the fortuitous concurrence of letters may not be impossible, all the books we know of have come about in another way.

Twenty-eight figures are required to express the number of distinct deals in whist. "If the whole population of the world, say one thousand millions of persons, were to deal cards day and night for a hundred million years," they might justify Sarah Battle's criticism of the game, but they would not in that time have exhausted one hundredth thousandth part of the possible deals.

It is not clear to me that combinations are latent in the things combined. In fact, the bearing of these things on the matter seems to be negative and passive, rather than active or positive.

It is not clear that, with all their latent potency, a pack of cards would ever evolve a single hand without a dealer; but if a part of the universe, so trivial and insignificant, presents opportunities so boundless, the matter and motion of our universe may present to a dealer opportunities for universes without end, no one like another, I do not see how one can assert that anything in the material universe is necessary or predetermined, except so far as it is one among an infinite number of possibilities.

Huxley tells us that, "if the fundamental proposition of evolution, that the whole world, living and not living, is the result of the mutual interaction, according to definite laws, of the forces possessed by the mole-

cules of which the primitive nebulosity of the universe was composed," be true, "it is no less certain that the existing world lay, potentially, in the cosmic vapor; and that a sufficient intelligence could, from a knowledge of the properties of the molecules of that vapor, have predicted, say, the state of the fauna of Great Britain in 1868, with as much certainty as one can say what will happen to the vapor of the breath in a cold winter's day."

The thoughtful reader will note that Huxley's assertion that, if this proposition be true, it is no less certain that the existing world lay, potentially, in the cosmic vapor is no admission that the proposition is true, or the deduction certain; nor must we forget that the most notable and valuable characteristic of Huxley's teachings is the declaration, in all his works, of the truth that the scientific basis of our confidence in the order of nature is evidence.

Again and again, in words which are unmistakable, he tells us that, while we may have reasonable confidence what to expect from the vapor of our breath in a cold winter's day, we know nothing about it except what has happened. The scientific value of our confidence depends, he tells us, on the extent of our experience of the behavior of the vapor of our breath, and similar bodies, on a cold day, or under similar circumstances. As, in this case, our experience is pretty extensive, the deduction is safe and reasonable; but when a young man who had passed his life in the tropics spent the night on top of a high mountain with my students he was so far from deducing anything from the frosty morning air that he was at first alarmed by the behavior of the vapor of his breath.

If Huxley is right; if the logical basis for confidence in nature is evidence, it seems clear that no amount of knowledge can ever give it any other basis; for nothing seems more obvious, or more strictly logical, than

our inability to deduce anything from a single experience. The burnt child may dread the fire as much as if it had been burned twenty times, but the only way for it to learn whether, and to what degree, its dread is wise and prudent, without passing through the slow and painful process of selection, is to get knowledge, for a single experience affords no basis for any logical process.

While the emotional value of a sensation is, no doubt, limited by inherited structure, and dependent, to some degree, on intensity, its objective value as knowledge is regulated in accordance with the statistical law of probability.

If the history of what we call *our* universe were complete from beginning to end; if everything which exists in it were reduced to mechanical principles, and traced back to primitive nebulosity, this history would be only a single experience in cosmogeny, so far as the history of universes is in question. If we were to find, somewhere, a second nebulosity we would not be able to infer anything, except from the worthless analogy of a single experience; nor would we be able to infer or deduce, from our own, anything, not already known, with more than reasonable confidence. If we were still ignorant of any part of our order of nature we should have no way to find out but the way we have now, and while our confidence in its stability would be reasonable and judicious it would not be necessary or absolute unless our experimental knowledge were also absolute.

It seems to me that the truth for which Huxley strives, and hits with imperfect aim, would be more correctly expressed by the statement that, if our knowledge of nature were to be made complete, from beginning to end, we should expect to find that our confidence in its stability had been reasonable and judicious, and wise through-

out, and that any other expectation would have been folly and suicide, bodily as well as mental, and that it is only in this sense that we could assert that it all lay potentially in the cosmic vapor.

It is not because I dread or fear the philosophy of evolution that I refuse to accept it, but because it is not yet proved. When it is proved I shall accept it with cheerfulness, for I most assuredly hold no belief which is inconsistent with it, although I fail to see how the reduction of all nature to mechanical principles could show that nature is determinate; for if exhaustive knowledge of 'primitive nebulosity' should sometime show that there is nothing in nature which might not have been expected, I cannot see how this could show why the things we expect should be the things which come about.

They who assert that complete knowledge would be fore-knowledge forget that, for minds like ours, the only source of knowledge, either complete or incomplete, is evidence; for evidence can tell us only what has happened, and it can never assure us that the future *must be* like the past. Even if we knew all that has happened, from the beginning down to the present moment, we should have to regard the unknown remainder as equal, in all probability, to the known past. To my mind, Jevons' demonstration that if certainty be represented by unity the utmost confidence we can ever reach by complete knowledge can never exceed a value of one-half seems conclusive; but even if it be increased until it differ from certainty by less than any assignable quantity it must still remain nothing but reasonable confidence.

There may be some unknown reason why the stone which I set free from my hand shall fall, and it may be that, as my mind has been shaped by natural selection, I am unable to expect anything else than that it shall fall; but science affords no evidence that its

fall is necessary or predetermined ; for most thoughtful students assure us that the inductive study of nature tells us nothing about it, except that, so far as we know, all stones so placed have fallen according to Newton's laws, and that we have not the smallest reason to expect that any stone so placed will act differently ; nor, so far as I can see, would prove that all nature is mechanical, from beginning to end, be inconsistent with belief that everything in nature is immediately sustained by Providence ; nor am I able to see how it would be inconsistent with my conviction that my volition counts for something as a condition of the course of events.

I have tried to show that, while the responsive activities of living things do not take place unless they are called forth by a stimulus, the things which they do under a stimulus are no more than their organic mechanism would lead one to expect, and that there is no necessary antagonism between those who attribute the development of the germ to mechanical conditions and those who attribute it to the inherent potency of the germ itself.

I have also tried to show that there need be no more antagonism between those who attribute knowledge to experience and those who attribute it to our innate reason ; for, while knowledge does not arise in our minds without a sensible occasion, the knowledge which does thus arise may be no more than one who knew the whole natural history of our minds might have expected.

We must now ask whether proof that all nature was latent in the cosmic vapor would be inconsistent with the belief that everything in nature is immediately intended rather than predetermined.

Certain monists tell us that the scientific doctrine of evolution is the same as Pantheism, for "since the simpler occurrences of inorganic nature and the more complicated phenomena of organic life are alike reduci-

ble to the same natural forces, and since, furthermore, these in their turn have their common foundation in a simple primal principle pervading infinite space, we can regard this last [the cosmic ether] as all-comprehending divinity, and upon this found the thesis: Belief in God is reconcilable with science."\*

They who agree with Haeckel may worship stones, if they see fit ; but they seem to me to fail as completely as any South Sea Islander to understand the nature of scientific evidence ; for it is one thing to find sermons in stones, and quite another to see a divinity in the stone itself, ' which, if with reason, we may do, then let our hammers rise up and boast they have built our houses, and our pens receive the honor of our writings.' But everything must be determinate, says the pious evolutionist, or what would become of the fixed order of nature ? Among the things that occupy the biologist are such aspects of nature as life, and consciousness, and volition, and reason, and right and wrong. Whatever these things mean, they are part of nature, and the zoologist cannot push them out of sight if others may. He does not know what their places in the system of nature are, but he would like to find out ; and he knows no way to find out except to discover.

When they who worship at the shrine of evolution tell him there can be no spontaneity in nature, because the order of nature is fixed and unchangeable, he asks what reason there is for thinking that proof that everything in nature is mechanical, and no more than might have been expected, would show that anything is fixed, or predetermined, or necessary.

Science has nothing to do with the notion of 'necessity,' and is quite content to leave it in the hands of its originators, the metaphysicians and theologians and 'philosophers,' who alone are responsible for all the mental confusion it has brought about.

\* Haeckel, 'Monism.'



What the man of science asserts is that he will not admit that anything is 'arbitrary.' "It was the ignorance of man's reason that begat this very name, and by a careless term miscalled the Providence of God; for there is no liberty for causes to operate in a loose and straggling way."\*

Belief that everything in nature is mechanical is neither more nor less than belief that everything in nature is orderly and what might have been expected; and if any one thinks that discovery that things do take place in order is any reason why they should, his distrust of science is only reasonable; for science is not for such minds as his.

It is in my mind to ask a question. Will any amount of knowledge of matter and motion tell the evolutionist whether I shall ask it or pass it by and go on to another subject? If he answer Yes I ask my question: How does he know? If he assure me that a being so reasonable as I am known to be will not ask anything that might not have been expected I thank him for the compliment, for I try to be a reasonable creature. But if he assert that his confidence in my thoughts and actions proves that they are *necessary* I must ask him how he knows; for I fail to see how proof that an event is mechanical and neither less nor more than might have been expected shows that it is *necessary*; nor can I see any more reason why my confidence in my freedom proves that my acts are *arbitrary*.

The man of science quarrels with no man's opinions, but he will not be held responsible for perplexities which are none of his making.

I am unable to share the dread of the evolutionist that the basis of science may be destroyed if we do not admit that all nature must be determinate. All agree that the past is determinate, so far as the word means anything to us, and there seems to

be valid ground for the belief that every part of the material universe contains a permanent record of every change which has ever occurred in any part.

"If on a cold polished metal, as a new razor, any object, such as a wafer, be laid, and the metal be breathed upon, and, when the moisture has had time to disappear, the wafer be thrown off, though now the most critical inspection of the polished surface can discern no trace of any form, if we breathe once more upon it, a spectral image of the wafer comes plainly into view, and this may be done again and again. Nay, more, if the polished metal be carefully put aside, where nothing can deteriorate its surface, and be kept so for many months, on breathing upon it again the shadowy form emerges. A shadow never falls upon a wall without leaving thereupon a permanent trace, a trace which might be made visible by resorting to proper processes. Upon the walls of our most private apartments, where we think the eye of intrusion is altogether shut out, and our retirement can never be profaned, there exist the vestiges of all our acts."\*

Babbage has pointed out ('Ninth Bridgewater Treatise,' pp. 113-115) "that if we had power to follow and detect the minutest effects of any disturbance each particle of existing matter would furnish a register of all that has happened. The track of every canoe, of every vessel that has as yet disturbed the surface of the ocean, whether impelled by manual force or elemental power, remains forever registered in the future movement of all succeeding particles which may occupy its place. The furrow which it left is, indeed, instantly filled up by the closing waters, but they draw after them other and larger portions of the surrounding element, and these again, once moved, communicate motion to others in endless succession. The

\* Religio Medici.

\* Draper, 'Conflict of Science and Religion.'

air itself is one vast library, in whose pages are forever written all that man has said or even whispered. There, in their mutable but unerring characters, mixed with the earliest as well as the latest sighs of mortality, stand forever recorded vows unredeemed, promises unfulfilled, perpetuating in the united movements of each particle the testimony of man's changeful will."\*

So far as we know, nothing that has ever been can be as if it had not been; and we seem to have good ground for believing that every portion of the material universe contains a record of every change that has taken place in all its parts, and also for believing that there is no limit to the power of minds like ours to read and interpret this record. Every new experience also shows that our expectation that the future will, on the whole, be like the past is reasonable. In these facts science finds a basis broad enough and firm enough for all our needs; for to this extent the data of science are latent in the physical universe, even if the future is, in part, to be what man and other living things make it.

If these evolutionists who hold that all nature is determinate and necessary are right, mind would seem to be useless. It may, for all I know to the contrary, be true that when I perform an action because my reason approves it neither the performance of the action nor the approval of my reason is anything more than exhaustive knowledge of the mechanism of my brain might have led one to expect; and if it follows that my action is necessary, and must take place, whether my reason approve it or not, reason would seem to be useless; but I cannot see why this should follow, for I fail to see how or why proof that my reason is mechanical and no more than might have been expected from my structure should be inconsistent with my confidence in its value, since I

cannot conceive how this proof could show that it is necessary, or predetermined, or useless.

I know the value of my reason by what seems to me the best of all evidence. If it were proved useless I should be quite ready to believe; but the improbability of this opinion seems to me so much like impossibility that I must ask for proof which is correspondingly conclusive; for I most assuredly refuse to give any weight to the 'faith' of pious evolutionists, and I must insist on my right to demand more evidence if more is to be had, for I cannot accept the mind of the evolutionist as a measure of nature.

Living things are continually bringing about rearrangements of matter and motion which would never, so far as I can see, have come about without them, and many of the things which they thus bring about are useful to the beings which bring them about. The earth would be very different in many respects if man had never inhabited it, and the effects of his activity will last as long as matter, whatever may be his fate. His influence upon the earth would have been very different if the plants of Carboniferous times had not stored up solar energy and worked their changes in matter millions of years ago. If the dodo, and the great auk, and the halicore, and the American bison, could tell their story they would bear witness that man is a factor in the order of nature.

They who are discontented with reasonable or 'moral' certainty, and tell us they want absolute certainty, must find this sort of certainty if they can and where they can, but their words seem strange to the zoologist. He knows that the rocks are full of the remains of organisms which passed out of existence because they were born in evil times, when the adjustments to the order of nature, which had served the purposes of their ancestors for millions of years, ceased to hold good.

\* Quoted by Jevons, 'Principles of Science,' p. 758.

If our race should ever find itself where the old order changes; if our reasonable expectations should disappoint us; if what we call the 'order' of nature should prove to be no more than natural selection would lead us to expect, and if a different selective standard should sometime modify this order, every zoologist knows that the human species would not be the first to meet this evil fate.

If, with Aristotle, we believe 'that is natural which holds good;' if, with Erigena, we hold that nature is the sum of all things, we cannot believe that life and consciousness and reason and volition are anything but part of nature. The question the zoologist would like to answer is what their place in nature is. So far as I am aware, no one believes that these aspects of nature exist in themselves, without antecedents, for we know that many of their antecedents are physical, and we want to find out, if we can, whether this is true of all of them or not. For my own part, I fail to see what bearing this wish has on the question whether the order of nature is 'fixed' or unfixed; nor can I see how proof that the conditions which, being given, are good reasons for expecting reason or the moral sense are mechanical should show that reason and morality are useless.

They who take refuge in an imponderable ether as soon as they find it difficult to discover, in ponderable matter, the key to all the antecedents to certain phenomena of light and electricity have no reason to cry out that the fixed order of nature is threatened, because the modest zoologist has not yet been able to find, in ponderable matter and physical energy, the key to all his problems.

Berkeley tells us that human knowledge has its basis in experience, and that its scientific value is to be measured by the amount of this experience; and Huxley assures us that there is but one kind of

knowledge and but one way to acquire it. They hold our practical test of truth to be evidence, although a pious evolutionist, who admits that, for all he knows, they may be right, is a heretic; for Herbert Spencer tells him that the Philosophy of Evolution stands or falls with the assertion that the ultimate criterion of truth is inability to conceive its negative.

If you will read Part VII. of his 'Principles of Psychology' with care you will note that its author tells us that unless we admit this we cannot be his disciples. It is not enough to admit ignorance of things ultimate, or to confess that, for all one knows, inability to conceive its negative may sometime prove to be the ultimate criterion of truth. One may admit that he is unable to discover any line which separates the responsive actions of living things in general from the rational actions of thinking men; that he does not know how or where instinct and impulse and emotion give place to reason. One may have as little faith in the idealism of Berkeley as he has in Spencer's realism, or in the materialism of German physics, or in the monism of the psychologists; but unless he knows what the relation between mind and matter is he cannot join the throng of worshippers before the shrine of this modern idol of the theater, for its leader tells him that suspension of judgment on this difficult question is as fatal as disbelief.

Proof that we should not be here if our remote ancestors had not responded to the order of nature as they did is no proof that our minds are a measure of nature, or that our responses will be valuable in the future, or that nature is determinate.

Now the difference between belief that the ultimate test of truth is the inconceivability of its negative, and belief that our practical test of truth is evidence, is this: that while inability to conceive the negative of a proposition may be absolute to us, as



nature has made us, at our present intellectual level, evidence is progressive, and can afford no basis for ultimate philosophy.

Our pre-Cambrian ancestors may have been unable to conceive the negative of many propositions, but what does the inability of a turnip or a sponge to conceive the negative of Newton's laws signify? Or what would our own inability signify if we should sometime find out that the ponderable matter which makes up what we call 'our universe' has been sifted out or segregated from other forms of matter by its property of weight? For no less distinguished an authority than Herschel held that there is proof of the existence of levitative matter as well as gravitative matter.

One volume of Herbert Spencer's 'Philosophy' is devoted to proof that we primarily know objects, but to this long argument Berkeley answers: Granted. Most assuredly we primarily know objects, but he tells us that the objects we know primarily are objects of sense.

So the frozen river of philosophy grinds on, scratching the surface of the everlasting hills, and melting before the genial sunshine of science, only to receive new accretions from the unknown and frozen space beyond the snow-line.

Some fifteen hundred years have passed since we were told by Proclus that "there are two sorts of philosophers. The one placed body first in the order of beings, and made the faculty of thinking depend thereupon, supposing that the principles of all things are corporeal; that Body must really or principally exist, and all other things in a secondary sense, and by virtue of that. Others making all corporeal things to be dependent upon Soul or Mind, think this to exist in the first place and primary sense, and the being of Bodies to be entirely derived from and to presuppose that of Mind.\*

\* Berkeley, 'Siris,' p. 263.

While the modern psychologist tells us that there is a third point of view, and that, for all we know to the contrary, both mind and matter may ultimately prove to be phenomenal; that all mind may be matter in motion, and all matter in motion mind, or at least the raw material of mind, I cannot see why the admission of this possibility compels us to take a side and make a choice; for may we not find a fourth alternative, in a humble confession that, while we do not know what the relation between mind and matter is, we wish to find out? "And, although it may, perhaps, seem an uneasy reflection to some that, when they have taken a circuit through so many refined and unvulgar notions, they should at last come to think like other men; yet, methinks, this return to the simple dictates of nature, after having wandered through the wild mazes of philosophy, is not unpleasant. It is like coming home from a long voyage: a man reflects with pleasure on the many difficulties and perplexities he has passed through, sets his heart at ease, and enjoys himself with more satisfaction for the future."\*

If the antecedents to consciousness are outside consciousness it seems no more than natural that we should be unconscious of them; and the zoologist who admits that he does not know whether they are or are not all to be found in that part of the universe which may be made manifest to sense does not feel guilty of a threat to the fixed order of nature, or to anything or anybody else.

There are two reasons why biology and the 'Philosophy of Evolution' should be associated.

In the first place, there is a wonderful analogy between the problems of the sensible universe and the unfolding of the latency of the germ into the potency of the fully developed living being. It is not impossible that the key to the more specific

\* Berkeley, Preface to 'The Three Dialogues.'

problem may fit the lock which seals the greater.

In the second place, the two subjects are historically associated. So long as men believed that species are distinct creations, no philosophy of evolution could have gained general acceptance. By convincing all thoughtful persons that species have a history which may be studied by scientific methods, Darwin led many who would not otherwise have given it a hearing, to treat the new philosophy with respect, but natural science is not 'philosophy,' notwithstanding this intimate historical connection between the proof that species are mutable and the spread of belief in the 'Philosophy of Evolution.' I have selected the passage which I have put at the head of this chapter in order to show that the view of the matter which is here set forth is not new, even among advanced biologists.

Huxley's attitude will, no doubt, be a surprise to many who think they have read his books with diligence. He continually calls himself an 'Evolutionist,' and he can hardly blame a reader who, failing to draw nice distinctions, holds him to be one of the chief pillars in the temple of the new philosophy. Some confusion may be permitted to those who remember his public lectures on 'Evolution,' his essays with the same title, and his declaration that the work of his life has involved him 'in an endless series of battles and skirmishes over evolution.'

It is easy for one who understands his true position to see that his essays lend no countenance to the opinion that he has ever been or sought to be either a pillar or a disciple of any system of philosophy, for he has never ceased from affirming his ignorance of many of the subjects which philosophy seeks to handle.

His evolution is not a system of philosophy, but part of the system of science. It deals with history—with the phenomenal

world—and not with the question what may or may not lie behind it.

During the last half century natural science has become historical. We have opened and learned to read a new chapter in the records of the past. The attributes of living things, which seemed to the older naturalists to be complete and independent in themselves, have proved to have a history which can be studied by the methods of science. They have been found to be steps in a long sequence of events as orderly and discoverable as the events which are studied by the astronomer or the geologist.

The cultivation of natural science in this historical field, and the discovery that the present order of living things, including conscious, thinking, ethical man, has followed after an older and simpler state of nature, is not 'philosophy,' but science. It involves no more belief in the teachings of any system of philosophy than does the knowledge that we are the children of our parents and the parents of our children; but it is what Huxley means by 'evolution.'<sup>\*</sup>

His lectures on 'Evolution' deal with paleontology, and narrate facts which are found in every text-book on the subject; but natural science, as it is taught in the text-books on botany and zoology and embryology and paleontology, is, most assuredly, no 'Philosophy of Evolution.' It fell to Huxley to fight and win a battle for science; and while he himself calls it a battle for evolution, his use of the word need mislead none, although it has misled many.

One word in its time plays many parts, and the word 'evolution' has had many meanings. To-day, in popular estimation, an evolutionist is not a follower of Bonnet; nor one who is occupied with the binomial theorem, or with the evolutions of fleets

<sup>\*</sup> See Huxley, 'Essays,' V. i., pp. 44-54.

and armies. Neither is he a cultivator of natural science. Whatever the word may have meant in the past, it has, in common speech, come to mean a believer in that philosophy of evolution which, according to such evolutionists as Huxley, is 'pre-mature.' Since this is so, and since the growth of language is beyond individual control, would it not be well for them to stand where Huxley stands, and 'have nothing to say to any philosophy of evolution,' to stop calling themselves 'Evolutionists,' and to be content with the good old name of 'Naturalist'?

To the pious evolutionist, who asks what will become of the fixed order of nature if we are not convinced that everything is determinate, we answer that, while this sort of reasoning is not new, it has a strange sound in the mouth of a student of science. The order of nature has outlasted many systems of philosophy, and it may survive others. We have found our astronomy and our geology and our law of the mutability of species, and none of the dreadful things predicted by 'philosophers' have come about. There may still be more things in heaven and earth than are dreamed of in 'philosophy.'

History warns us that, as the price of progress in science, all the idols of the theater, and all other idols, "must be abjured and renounced with firm and solemn resolution, and the understanding must be completely freed and cleared of them, so the access to the kingdom of man, which is founded on the sciences, may resemble that to the kingdom of heaven, where no admission is conceded except to children."

If the world thinks hard names are the just due of them who assert their living wish to know, while humbly confessing ignorance, the biologist must bear up as well as he can if he is called a 'scientific Rip Van Winkle,' or an 'agnostic,' or even 'a turbaned and malignant Turk.'

If we seek admission to the temple of

natural knowledge naked and not ashamed, like little children, hard names cannot hurt us, nor need they scare us.

W. K. BROOKS.

JOHNS HOPKINS UNIVERSITY.

*FERMENTATION WITHOUT LIVING CELLS  
AND SYNTHETIC PROTEIN.*

I TAKE pleasure in complying with the request of the Editor to furnish the readers of SCIENCE with a brief abstract of the papers read at the late Vienna Congress by Professor Buchner, of Tübingen, and Dr. Lillienfeld, of Vienna, on 'Fermentation without Cells' and 'The Synthesis of Albumenoids,' respectively. The paper of Professor Buchner was presented to the whole Congress on the occasion of the first general meeting, July 28, 1898. The paper was illustrated with numerous experiments showing the production of vigorous fermentation within the time occupied by reading the paper, secured by ferments entirely free of yeast cells. The active principle of the yeast cells is obtained by grinding the yeast with quartz sand, for the purpose of disrupting the cells, and subsequently submitting the moist mass to a high pressure, viz: 500 atmospheres. Nearly all the yeast cells are disrupted by this process, and a microscopic examination of the residue discloses the empty cells from which all liquid contents have been removed. A more complete evacuation of the contents of the cells is secured by breaking up and moistening the press cake and repeating the grinding and pressure. About half a liter of liquid is obtained from a kilogram of yeast. The liquid contents of the cells, as they come from the press, are filtered through fine paper, in order to remove any danger of whole yeast cells being found in the extract.

The resultant liquor is clear or slightly opalescent, has a yellowish color and the pleasant odor of yeast. It contains con-



siderable quantities of carbon dioxid and some coagulable albumen. That the prepared juice contains enzymes is easily shown by the hydrogen peroxid test. Hydrocyanic acid has the property of forming a very unstable compound with these enzymes whereby the action of hydrogen peroxid is prevented, and scarcely any oxygen is given off from such a mixture until the acid has been partly or entirely removed by a current of air. Of the enzymes present invertin has been detected, and it is probable that another ferment capable of hydrolyzing maltose and glycogen is present.

Most interesting is the department of the yeast juice towards sugars. Fermentation is set up much quicker than by yeast and proceeds much faster. Quite a number of sugar solutions treated with the ferment at the beginning of the paper were in rapid action before the close. The evolved gas is almost pure carbon dioxid. The reaction is made much quicker if a small amount of sugar is dissolved in large volume of the yeast liquor. The vitality of the ferments continues for two or three days, after which time their activity is rapidly diminished. When carefully dried at a low temperature the vitality of the ferments is not destroyed, and it is probable that in a desiccated state the active properties of the mixture may be kept indefinitely without loss.

It follows, as a result of these investigations, that living cells are not necessary to fermentation, and thus another of the fetiches of the old chemistry is destroyed. Fermentation can no longer be regarded as a physiological act produced by living organisms. It is simply due to the chemical power of an amylolyte acting in a manner entirely similar to the ordinary digestive ferments. It has not yet been possible to isolate the fermentative enzyme, partly because of its instability, but chiefly because of the presence of other enzymes, such as invertin and the oxydases, which deport

themselves analytically in the same manner as the fermenting bodies.

In regard to the practical uses which may be made of this discovery little can be said. By reason of the fact that the fermentative organisms can be preserved in a dry state, it ought to be possible to secure a more general distribution of those particular yeasts which give the highly-prized flavors to beers and even to wines. If this be the case the flavors which are produced in the great breweries of the Old World might be produced under proper conditions in the breweries in other countries. It would be wise, however, to postpone any discussion of the practical applications of the discovery of fermentation without living cells until the matter has been more thoroughly worked out from the purely scientific point of view.

The paper of Dr. Lilienfeld, as has already been intimated, referred to the synthesis of a nitrogenous body having the properties of a peptone or even of an albuminoid or proteoid. The synthesis of such a peptone or peptonoid marks a distinct step forward in synthetical work in the field which has already been partly developed by Grimaux, Pickering, Williamson and others.

We can only now speak, however, of its centesimal composition. The state of its molecular condensation and atom position can only be determined by securing large quantities of the product and submitting it to chemical and digestive studies. It is probable that, as in the case of sugars, the artificial peptone will lack the vital element. In other words, while the chemist has succeeded in building molecules which resemble, in every outward respect, those built up by Nature, they are uniformly dead, without cell functions or cell activity. The details of this important scientific work must be awaited before a final judgment in regard to its far-reaching importance can be formulated.

The synthesis of peptone is effected by the condensation of phenol with glycocoil with the help of phosphoroychlorid. A hydrochlorate of peptone results, which gives all the characteristic reactions of protein. By conversion into sulfate and the decomposition of the latter the free peptone is obtained, which it is claimed by Lillienfeld is similar both in chemical and physiological properties to the natural product.

It is evident from the method of preparation that the product contains no sulfur, since the only sulfur-containing ingredient used was sulfuric acid, and this could not possibly enter into the organic preparation. Granting that a peptonoid body was produced, the synthesis of a true proteid, which must contain sulfur, is still undemonstrated.

The color reactions which are supposed to be characteristic of protein must not be relied on too surely. They are probably due to decomposition, and not to the action of the molecule as a whole. It is stated by Pickering that a mixture of tyrosin, indol and biuret will give all the reactions characteristic of a proteid. If the prospects of artificial food depended on these so-called synthetic products the vocation of the geonist would be assured for many millions of years to come.

The interesting fact, however, in papers of this kind is found in the accomplishment of steps which a few years ago were considered improbable or impossible. It is certain that the chemist is now able to produce organic compounds, or bodies which closely resemble them, in great numbers, if not in considerable quantities. Practically, such investigations will lead to further studies in the domain of synthetic chemistry and doubtless to the discovery of many additional synthetic products of great utility. In so far as the production of artificial food is concerned, however, there seems to be

absolutely no possibility of Nature's methods ever being supplanted or even greatly supplemented by the synthetical products of the laboratory.

H. W. WILEY.

DIVISION OF CHEMISTRY,  
DEPARTMENT OF AGRICULTURE.

*THE 'FEELING OF BEING STARED AT'*

EVERY year I find a certain proportion of students, in my junior classes, who are firmly persuaded that they can 'feel' that they are being stared at from behind, and a smaller proportion who believe that, by persistent gazing at the back of the neck, they have the power of making a person seated in front of them turn round and look them in the face. The phenomena are said to occur in any sort of assembly—at church, in the class room, in a public hall. The 'feeling,' when it is not merely described as 'uncanny,' 'a feeling of Must,' etc., is referred to as a state of unpleasant tension or stiffness at the nape of the neck, sometimes accompanied by tingling, which gathers in volume and intensity until a movement which shall relieve it becomes inevitable. It is believed that this stiffness is, in some way or other, the direct effect of the focussing of vision upon the back of the head and neck.

The belief rests upon a foundation of fact, but (like most popular beliefs) implies a misinterpretation of fact. The psychology of the matter is as follows: (1) We are all of us more or less 'nervous' about our backs. If you observe a seated audience, before it has become absorbed in the music or lecture for which it came together, you will notice that a great many women are continually placing their hands to their heads, smoothing and patting their hair, and every now and again glancing at their shoulders or over their shoulders to their backs; while many of the men will frequently glance at or over their shoulders,

and make patting and brushing movements with their hand upon lapel and coat-collar. This sort of anxiety about the back varies considerably from individual to individual, but most of us are probably aware that we share it to some extent. A friend of mine, who learned to dance after he had arrived at man's estate, told me that it was positively painful to him to turn his back upon the instructor (even during a private lesson), and that it was as positive a relief when he was allowed to face the instructor's back, and posture unseen. Some lecturers are very averse, again, to turning their backs upon an audience, even for the few moments that are required for blackboard writing. It is not difficult to imagine a phylogenetic reason for this shyness, and for the exploring movements of eyes and hands, when we remember that the organs of sight are placed for *forward* vision, and think of the constant care that must have been devoted to the defenseless back when our ancestors first assumed the upright position. But, however that may be, there can be no doubt of the facts at the present day.

(2) Since it is the presence of an audience, of people seated behind one, that touches off the movements described above, it is natural that these movements should in many cases be extended so as to involve an actual turning of the head and sweeping of the eyes over the back of the room or hall. Not only is one nervous about one's appearance as viewed from behind; one is also anxious that this nervousness shall not be apparent. It is not good breeding to be concerned about one's looks in a public place. Hence there is often a voluntary continuation of the original ideomotor movements; one looks round inquiringly, as if one were seeking for a special person or event—taking one's direction from some chance noise of falling seats or rustle of dresses, letting one's eyes come to rest

upon some patch of intense color, etc., etc. The details differ in different cases; the general mechanism is the same. Observe that all this is entirely independent of any gaze or stare coming from behind.

(3) Now, movement in an unmoved field—whether the field be that of sight, or hearing, or touch, or any other—is one of the strongest known stimuli to the passive attention. We cannot help but attend to movement; and phylogenetic reasons are again not far to seek. Hence if I, *A*, am seated in the back part of a room, and *B* moves head or hand within my field of regard, my eyes are fatally and irresistibly attracted to *B*. Let *B* continue the movement by looking round, and, of course, I am staring at him. There are, in all probability, several people staring at him, in the same way and for the same reason, at various parts of the room; and it is an accident whether he catch my eye or another's. Someone's eye he almost certainly will catch. Moreover, as there are many others, besides *B*, who are afflicted with *B*'s restlessness, it is an accident, again, whether my neighbors, to right and left, are also looking at *B*, or are looking at some part of the room quite remote from *B*. Both of these accidents, until they are recognized as accidents, evidently play into the hands of a theory of personal attraction and telepathic influence.

(4) Everything is now explained, except the feeling that *B* experiences at the back of his neck. This feeling is made up, upon its sensation side, simply of strain and pressure sensations which, in part, are normally present in the region (sensations from skin, muscle, tendon and joint), but are now brought into unusual prominence by the direction of attention upon them, and, in part, are aroused by the attitude of attention itself. 'Nervousness' about one's back means, psychologically, constant attention to the sensations coming from, and the



mental images of, that portion of the body; and attention, in its turn, means in most cases movement of the part of the body attended to. If one thinks hard of one's knee, or foot, *e. g.*, one will obtain a surprisingly intensive and insistent mass of cutaneous and organic sensations of which one was previously unconscious, or at best but very dimly conscious; while, at the same time, there is an actual twitching or bracing of the knee or foot, which sets up new sensations. Any part of the body will thus yield up its quantum of unpleasant sensation, if only for some reason the attention can be continuously held upon it, to the exclusion of other topics. The 'feeling of Must' in the present case is no more mysterious than is the 'feeling of Must' that prompts us to shift our position in a chair, when the distribution of pressures has become uncomfortable, or to turn our better ear to the sound that we wish particularly to observe.

(5) In conclusion, I may state that I have tested this interpretation of the 'feeling of being stared at,' at various times, in series of laboratory experiments conducted with persons who declared themselves either peculiarly susceptible to the stare or peculiarly capable of 'making people turn round.' As regards such capacity and susceptibility, the experiments have invariably given a negative result; in other words, the interpretation offered has been confirmed. If the scientific reader object that this result might have been foreseen, and that the experiments were, therefore, a waste of time, I can only reply that they seem to me to have their justification in the breaking-down of a superstition which has deep and widespread roots in the popular consciousness. No scientifically-minded psychologist believes in telepathy. At the same time, the disproof of it in a given case may start a student upon the straight scientific path, and the time spent may thus be repaid to

science a hundredfold. The brilliant work of Lehmann and Hansen upon the telepathic 'problem' (*Philos. Studien*, 1895, XI., 471) has probably done more for scientific psychology than could have been accomplished by any aloofness, however authoritative.

E. B. TITCHENER.

CORNELL UNIVERSITY.

WHAT IS *SCIURUS VARIEGATUS ERXLEBEN?*

WHILE working out the synonymy of the Mexican squirrels I have had occasion to consult the much quoted *Historiæ Animalium Novæ Hispaniæ* of Fernandez, edition of 1651. The descriptions of birds and mammals in this work have served as the basis for many species named by succeeding authors whose vagueness of description and lack of definite information concerning the geography and animal life of Mexico have resulted in great confusion. At the time when Fernandez made his observations the main area of Spanish occupation in Mexico was the southern end of the Mexican tableland, about the valley of Mexico, and thence eastward across the plains of Puebla, through the Cordillera (crowned by the peaks of Orizaba and Cofre de Perote) to the hot lowlands of Vera Cruz. For several seasons zoological explorations have been conducted in this area by the writer, who, as a result, has become familiar with the topography and resident species of birds and mammals. In the light of this knowledge it is possible to identify, with certainty, many of Fernandez's species, for example his *Quauhtecallotlquapachtli* or *Coziocotequallin*.\*

In 1777 Erxleben, in his *Systema Regni Animalis, Mammalia*, p. 421, named this animal *Sciurus variegatus*. Since Erxleben derived his information from Fernandez it becomes necessary to learn what the latter says. Following is the translation of Fer-

\* *Hist. Animalium*, p. 8.

andez's description: "The second is called *Quauhitecallotlquapachli* or *Cozticocotquallin* from the yellow color of the belly; it grows nearly twice the size;\* in color is white, black and brown mixed, except the belly, which is pale or fulvous; it has a very long and hairy tail, with which it sometimes covers itself. It lives in holes in the ground and in enclosed hollows, in which it also rears its young. It feeds on Indian corn, which, taken from the fields, it stores up for winter. It is agile like the others, never becomes tame or lays aside its natural wildness."

The vague ideas prevailing among writers regarding the animal described by Fernandez and Erxleben is evident when it is known that at least twelve well-marked species and sub-species of American squirrels have been referred to it. These squirrels represent species having distinct ranges, lying between the Carolinas in the United States and Honduras in Central America. Since the species was named by Erxleben it has been uniformly treated by authors as a true *Sciurus*. Now let us see what foundation there is for treating this species as a true squirrel. Erxleben places it under his *Sciurus*, but, as he covers in this genus several genera now considered distinct, this furnishes no guarantee of its actual generic position. It is true that he quotes as a synonym the *Coquallin* of Buffon, but this merely shows that, in naming the animal of Fernandez, Erxleben had no very definite idea of it. Erxleben's description, evidently quoted from Fernandez, is as follows: "Magnitudine dupla *S. vulgaris*. Auriculæ imberbes. Corpus supra nigro, albo et fusco variegatum, ventre flavescens. Cauda supra corpus reflexa." This description might easily refer to a *Sciurus*, but when the author adds the fol-

lowing notes, viz., "Habitat in Mexico. Subterraneus parit, cibumque colligit pro hieme. Edit Zeam. Non mansuescit." it is evident that he is describing a *Spermophilus*.

I think it may be positively stated that no Mexican *Sciurus* has the habits of the animal described by Fernandez. The *Spermophilus macrourus* of Bennett and later authors is an abundant resident throughout the part of the tableland familiar to Fernandez. It is conspicuous about farms, and agrees in habits and colors with the animal described by Fernandez and quoted by Erxleben, and again described by Lichtenstein as *Sciurus buccatus* (Abh. k. Akad. Wiss., Berlin, pp. 115, 117 (1827), 1830). This being the case, it is difficult to see how there can be any reasonable doubt that the *Quauhitecallotlquapachli* of Fernandez, the *Sciurus variegatus* of Erxleben, *Sciurus buccatus* of Lichtenstein and *Spermophilus macrourus* of Bennett are one and the same animal. Consequently the large, bushy-tailed *Spermophilus* of the Mexican tableland becomes *Spermophilus variegatus* (Erxleben) and stands as the type of the group to which belong *S. couchi* and *S. grammurus*, which are probably races of this species. It was probably about the border of the Valley of Mexico, near the City of Mexico, that Fernandez became familiar with this animal, and we may, therefore, consider this as the type locality.

NOTE: *Spermophilus mexicanus* (Lichtenstein) is the only other common and widely spread species of *Spermophilus* on the southern end of the Mexican tableland and it is readily recognizable as the *Techallotl* of Fernandez.

E. W. NELSON.

NOTES ON PHYSICS.  
TRANSFORMER DESIGN.

A PAPER by F. W. Carter read before the November meeting of the American Institute of Electrical Engineers gives, for the

\* The context shows that this must refer to the author's *Techallotl*, which is *Spermophilus mexicanus* (Licht.).

first time, a method for the rational design of alternating current transformers. Our knowledge of this important piece of apparatus has, up to this time, consisted in part of a precise and complete knowledge of its behavior and in part of a keen sense of propriety in design on the part of the more progressive practical electricians; but a rational method for correlating the various items in the design with a view to the production of a transformer which shall at once meet prescribed conditions in the best possible way we have not had. The method has rather been to assume (on paper) a large number of alternative designs, to calculate the action of each in detail, and to adopt that design which best meets all the requirements.

It is only fair to the practical electricians to say that Mr. Carter's results will not invalidate much, if any, of their more recent work for the reason that the old method of designing is fully adequate if enough labor is devoted to it, and this condition has been abundantly satisfied. Teachers of electrical engineering, on the other hand, may hail Mr. Carter's paper with satisfaction as affording further occasion for the application of elegant mathematics—not used in practice!

#### UNDERGROUND ELECTRIC CURRENTS IN NEW YORK CITY.

THERE is a serious and growing trouble with gas and water pipes, due to hurtful electrolytic action of underground electric currents, mainly from trolley lines. Mr. A. A. Kundson has recently reported to the American Institute of Electrical Engineers the results of an electrical survey of New York City and of the Brooklyn Bridge. He finds the conditions at the anchorages to be such as have been known to do serious hurt to water pipes, although, as he points out, the action upon the massive iron anchors to which the suspending cables are attached may be very slight, be-

cause of their being surrounded by concrete in which there is a certain amount of free lime and a definite lack of those chemical salts which conduce to destructive electrolytic action. The matter is, however, sufficiently serious to be taken into deliberate consideration, as it is unlikely that the anchors can withstand the present action for a long series of years.

#### HIGH-VOLTAGE POWER TRANSMISSION.

MR. CHAS. F. SCOTT has recently presented to the American Institute of Electrical Engineers the results of some unique tests of high voltage transmission lines. These tests have been made partly in the laboratory by Mr. Scott and partly upon the operating plant at Telluride, Colorado, by Mr. Mershon. One of the most interesting of the results is that the loss of power due to discharge between the two wires (outgoing and returning wires) begins to be excessive when the e. m. f. reaches about 50,000 to 60,000 volts. This kind of loss was one of the uncertainties which confronted the engineers who installed the now classical plant which transmitted power (at 30,000 volts) from Schaffhausen to the Electrical Exhibition at Frankfort in 1891, and these tests of Mr. Scott are the first to show just when this loss becomes considerable under practical conditions. The highest e. m. f. at present used in power transmission is 40,000 volts at the Provo plant of the Telluride Power Transmission Company in Utah, which transmits power to a distance of thirty-five miles.

W. S. F.

#### NOTES ON INORGANIC CHEMISTRY.

THE current number of *Nature* contains a full abstract of a paper read by Professor W. C. Roberts-Austen at the Institution of Civil Engineers on the extraction of nickel from its ores by the Mond process. This process is an entirely new departure in



metallurgical practice and also in the principles thus far applied. It depends upon the fact that nickel forms a volatile compound,  $\text{Ni}(\text{CO})_4$ , by direct union with carbon monoxid, and that this compound is decomposed with deposition of metallic nickel at  $180^\circ$ . The compound was discovered by Dr. Ludwig Mond in course of an attempt to eliminate carbon monoxid from gases containing hydrogen. The only other metal forming similar volatile compounds with carbon monoxid is iron; hence it seemed possible to utilize the reaction for the practical separation and purification of nickel. An experimental plant was erected at Smethwick, near Birmingham, in 1892, using as a source of nickel 'Bessemerised' matte. The matte, after dead roasting, contained 35% nickel, 42% copper and 2% iron. Two-fifths of the copper was extracted by sulfuric acid and marketed as sulfate. This residue, containing 51% nickel, was then reduced by water gas, care being taken not to reduce the iron. The material was then submitted to the action of carbon monoxid in a tower at a temperature not exceeding  $100^\circ$ , the volatile compound being passed to the reducer, where the nickel was deposited. The carbon monoxid was circulated between the tower and the reducer for a period varying from seven to fifteen days, in which time 60% of the nickel had been removed as nickel carbonyl. The residue was then returned to the first stage of the process. The nickel was deposited in the reducer, either on thin sheets of iron or on granules of ordinary commercial nickel. The product contained 99.8% nickel. This plant is now in full working operation and over 80 tons of nickel has been extracted from different kinds of matte. The conclusion is reached that this process is well able to compete with any other process in use for the production of metallic nickel. Professor Roberts-Austen pointed out that its application

to the nickel ores of Sudbury, Ontario would probably contribute largely to the resources of the Dominion.

CONTINUING his researches on metallic lithium and calcium, Moissan finds that these metals are soluble in anhydrous ammonia, forming compounds more stable than those with the other alkalies. The substances are represented by the formulæ  $\text{Li}_3\text{NH}_3$  and  $\text{Ca}_2(\text{NH}_3)_4$ , the ammonia being apparently analogous to water of crystallization. Both of these compounds take fire on coming in contact with the air at ordinary temperature.

THE interesting investigations of H. N. Stokes on the compounds of phosphorus and nitrogen are continued in the November issue of the *American Chemical Journal*. It is found that on saponification, the series of chlorids  $(\text{PNCI}_2)_n$  gives rise to a corresponding series of acids  $(\text{PNO}_2\text{H}_2)_n$ . The compounds where  $n$  is 3, 4, 5 and 6 have been formed, but when  $n$  is 7 the chlorid yields an acid of the formula  $(\text{PNO}_2\text{H}_2)_7 + \text{H}_2\text{O}$ . The constitution of these compounds is represented by a ring formula where the phosphorus and nitrogen alternate. This ring may thus contain 6, 8, 10 and 12 atoms, but when 14 atoms are present the limit is passed and the typical constitution is departed from. Applying the tension theory of von Baeyer regarding carbon atom rings, in which he finds that the most stable ring is that which contains five carbon atoms (the pentamethylene ring), Stokes finds that the phosphorus-nitrogen ring containing eight atoms would be most stable, and this is exactly borne out by the facts,  $\text{P}_4\text{N}_4\text{O}_8\text{H}_8$  being the most stable of these acids. This analogy existing between the carbon rings and those of other elements is an interesting broadening of chemical theory.

THE question as to the origin of petroleum continues to attract experimenters.

In his inaugural dissertation at Freiberg, Th. Lehmann finds that the distillation of fish remains under pressure gives rise to an oil which in its constituents shows a very close resemblance to petroleum, and hence the conclusion is drawn that petroleum deposits have arisen from the remains of sea animals. There is, however, in this work little advance on that of Engler. The well recognized fact that petroleum could have been formed in this way by no means proves that all petroleum has this origin, or that some or much has not been formed according to the theory of Mendeleef from the action of water upon metallic carbids in the deeper layers of the earth's crust.

J. L. H.

#### CURRENT NOTES ON ANTHROPOLOGY.

##### RUSSIAN ETHNOGRAPHY.

AN unusually interesting article is that on the ethnography of the Slavic stock, by Professor W. Z. Ripley, in the *Popular Science Monthly* for October last. He finds a remarkably uniform type of head form among the Russians due, he believes, to the uniformity of their environment. Two contrasted psychical types, however, coexist throughout the Slavic nations—the one tall, blonde, long-skulled; the other of medium stature, swarthy, broad-skulled. Which represents the primitive Slavic type? Desperate contests, in which much ink has been shed, have been fought over this point by the learned of Europe. Professor Ripley does not shout in a clarion voice with either combatant, but 'rather inclines to believe' that more can be said in favor of the latter. 'The Slaves penetrated Russia from the southwest,' driving before them a primitive people ethnically allied to the Finns, hence of north Asiatic origin.

##### ARGENTINE ETHNOGRAPHY.

UNDER the title *Etnografía Argentina*, Sr. Felix F. Outes has published a supplement

to his work on the Querandi Indians, mentioned in these notes (October 7, 1898). He repeats and defends his opinion that they belonged to the Guaycuru stock of the Chaco. His arguments do not seem to me convincing. The Querandi proper names appear to belong to an Aucanian dialect, and when they were driven from the coast they fled to the Ranqueles, who are a known branch of the Aucanian family.

In an article in the *Bollettino della Società Geografica Italiana*, 1897, Sr. Guido Boggianni copies and describes the singular rock inscriptions at the 'Gorgo das Pedras,' not far from Corumba, State of Matto Grosso. They are alleged to be extremely ancient, the modern Indians denying knowledge of their origin or meaning. They present familiar types of aboriginal petrographs, human foot-prints, bird foot-prints and the signs for man, etc.

##### THE ETHNOLOGICAL SURVEY OF CANADA.

THE second report of the Committee on the Ethnological Survey of Canada, presented to the British Association last August, has been issued. It contains a brief official report of progress and an Appendix including 'Haida Stories and Beliefs,' by Professor C. Hill-Tout, and 'Customs and Habits of Earliest Settlers of Canada,' by Mr. B. Sulte. The Association now makes an appropriation for this work and it is progressing more rapidly.

Both the papers in the Appendix are valuable original contributions, though one cannot but regret to see that Professor Hill-Tout is engaged in discovering the affinities between the Salish dialects of British Columbia and the Polynesian languages. That is a step twenty years backward in linguistic science. Mr. Sulte's picture of the early settlers and their mode of life is vivid and striking.

D. G. BRINTON.

UNIVERSITY OF PENNSYLVANIA.

## SCIENTIFIC NOTES AND NEWS.

At a meeting of the Paris Academy of Sciences, on November 28th, Professor O. C. Marsh, of Yale University, was elected a correspondent in mineralogy. Forty-four votes were given to Professor Marsh and four to Professor Zittel, of Munich.

WE regret to learn that Professor George J. Brush is dangerously ill at New Haven with pneumonia. It will be remembered that Professor Brush recently resigned the directorship of the Yale Sheffield Scientific School, to take effect at the end of the present year. Like President Dwight, he resigns owing to the fact that he has about attained the age of seventy years.

QUEEN VICTORIA has appointed Professor D'Arcy Wentworth Thomson, M.A., of University College, Dundee, to be Scientific Member of the Fishery Board for Scotland, in the room of Sir John Murray, F.R.S., resigned.

THE Society for Plant Morphology and Physiology will hold its second annual meeting at 505 Shermerhorn Hall, Columbia University, Tuesday to Friday, December 27th to 30th. On Tuesday evening, from 8 to 11, a reception is to be tendered by the Torrey Botanical Club, of New York, to the members of the Society and other visiting botanists, in the rooms of the Department of Botany in Columbia University. The address of the retiring President, Dr. W. G. Farlow, is to be delivered on Wednesday at 4 p. m. The Society will unite with the American Society of Naturalists in their programs for Thursday afternoon and Wednesday and Thursday evenings.

THE local committee of the American Society of Naturalists and Affiliated Societies has, in view of the meetings next week, sent to members an announcement containing references to some of the more important institutions and collections of New York City. Since the Society of Naturalists met in New York, in 1889, the City has shown great scientific activity. Columbia University and New York University have been established on new sites, and special attention has been given to the erection and equipment of the scientific laboratories. The American Museum of Natural History—both the

buildings and the collections—has been greatly enlarged and will be open especially to members on Tuesday. An Aquarium and a State Pathological Institute have been established. The Botanical and Zoological Parks, in their present unfinished condition, will be shown to members of the Societies by Director Britton and Director Hornaday on Friday.

WE regret to record the death of Dr. John Stillwell Schanck, emeritus professor of chemistry and hygiene in Princeton University, which occurred at Princeton on December 16th. Dr. Schanck was born in 1817, and began the practice of medicine at Princeton in 1843. In 1847 he was made lecturer in zoology at the College, and in 1856 was elected professor of chemistry, to which the chair of natural history was added in 1869. In 1874 the professorship was limited to chemistry, and from 1885 until he was made emeritus professor, in 1892, his chair was entitled chemistry and hygiene.

WE must also note the death of Mr. George Woodroffe Goyder, late Surveyor-General of South Australia, and of M. D. Meritens, the French electrician.

THE *British Medical Journal* gives further details of the unveiling of the monument to Charcot on December 4th. Addresses were made by Professor Brouardel, who presented the monument to the city on behalf of the faculty of medicine; by M. Navarre on behalf of the Municipal Council; by Professor F. Raymond, Charcot's successor at the Salpêtrière; by Professor Cornil, Charcot's successor in the chair of pathology in the École de Médecine, and by M. Georges Leygues, the French Minister of Public Instruction. The statue has been modelled in bronze by the distinguished sculptor, M. Falguière, with the collaboration of the well-known architect, M. Samson. Charcot is represented in his professorial robes standing in the act of giving a demonstration, the right hand indicating the left temporal region on the head of a dead body lying beside him, and the left making a gesture habitual to him in lecturing.

MR. A. E. SHIPLEY, of Christ's College, and MR. H. S. Croniu, of Trinity College, have been appointed to represent Cambridge Univer-



sity at the celebration of the centenary of the Imperial Military Academy of Medicine at St. Petersburg on the 30th inst.

MR. J. GRAHAM KERR, of Christ's College, Cambridge, has been awarded the Walsingham medal for his researches on *Lepidosiren*.

THE Zoological Society of London has sent Mr. John S. Budgett to Western Africa to study the fauna and to make collections for the Gardens.

THE *American Naturalist* states that Mr. C. F. Baker, of the Alabama Experiment Station, is about to start on a collecting trip to South America which will last eighteen months.

FROM the *American Geologist* we learn that Mr. Oscar H. Hershey has returned to his home at Freeport, Illinois, after a scientific expedition to the Isthmus of Panama.

THE United States Civil Service Commission announces that it is desired to establish an eligible register from which a selection may be made to fill an existing vacancy in the grade of assistant engineer, electrically qualified, at a salary of \$1,000 per annum, in the custodian service at Baltimore, Md. Eligibility for appointment will be determined from an examination into each applicant's experience, ability and character as a workman, and physical qualifications for the work to be performed.

A POLAR reflecting photographic telescope, with its building and dome, is being erected for the observatory of Cambridge University and is now nearly ready for use.

WE take from *Natural Science* the following items: Dr. Jonathan Hutchinsou is erecting for Selby, in Yorkshire, an Educational Museum similar to the one established by him in Hazelmere. A Museum of Natural History has been opened at King Williamstown, Cape Colony. The Sheffield Literary and Philosophical Society has presented Dr. H. C. Sorby with his portrait, by Mrs. M. L. Waller, in celebration of his fifty years' connection with the Society (1847-1897).

THE French Academy has received a legacy of 120,000 francs for the establishment of a prize that will appear somewhat curious to

Anglo-Saxons. It is to be awarded for 'the most beautiful example of love and devotion between brothers and sisters.'

THE will of the late Edwin F. Knowlton gives \$40,000 for the establishment of a library in West Upton, Mass. Mr. G. F. Logan, of Chicago, has given \$35,000 for the erection of a library building for the Art Institute of that city. The will of the late John L. Gardner, of Boston, bequeathes \$275,000 for public purposes, to take effect on the death of his wife; \$100,000 is given to the Boston Society of Fine Arts, and \$25,000 to the Brookline public library.

THE Museum of Anatomy and Anthropology at Cambridge has received from Professor Flinders Petrie a collection of skulls and bones secured at Hieraconopolis, representing prehistoric and the early dynastic races of Egypt.

MR. ALFRED JONES has subscribed £350 annually for the maintenance in Liverpool of a laboratory of tropical diseases. It will be under the direction of Professor Boyce.

AT the nineteenth annual meeting of the Biological Society of Washington for the election of officers, on Saturday, December 17th, the following were elected for 1899:

President, F. V. Coville; Vice-Presidents, W. H. Ashmead, B. W. Evermann, F. A. Lucas, C. W. Stiles; Recording Secretary, H. J. Webber; Corresponding Secretary, O. F. Cook; Treasurer, F. H. Knowlton; Additional Members of the Council: C. L. Marlatt, T. S. Palmer, C. L. Pollard, F. W. True, M. B. Waite.

MR. J. LARMOR has been elected President of the Cambridge Philosophical Society. The Vice-Presidents are Mr. F. Darwin, Professor Forsyth and Dr. Gaskell; and members of the Council: Mr. H. Gadow, Mr. D. Sharpe and Professor J. J. Thomson, Mr. A. Berry and Mr. Wilberforce.

AT a special meeting of the American Society of Civil Engineers on December 14th Mr. Hiram S. Maxim gave an illustrated lecture describing his experiments in artificial flight and the evolution of the automatic gun.

THE New York Society for Child Study will hold its fourth session at Syracuse on December 28th. Professor E. F. Buchner, the Secretary of the Society, will give an address upon its

work, and among the papers is one on fatigue by Dr. Smith Baker.

THE annual meeting of the Pennsylvania Forestry Association was held on December 12th at the College of Physicians and Surgeons, Philadelphia. President John Birkinbine made an address, and a report was read by the General Secretary, Dr. Joseph T. Rothrock. Dr. Rothrock said, according to the report in the Philadelphia *Ledger*, that there had been a great increase in the interest shown by the people during the last year in the work of the Association. They were apparently being educated up to an appreciation of the value of restoring the trees to the denuded hills. He also referred with gratification to the active sympathy shown by the Fish Commission and Game Protective Association, who had a mutual interest in the preservation of the forests. Referring to the three reservations authorized by the Act of Assembly, he said the land purchased by the State this year at tax sales amounted to 55,000 acres, and that he had personally examined many other tracts. Most of the tracts purchased are contiguous, but those which are not could be sold, as a rule, for more than they cost, and the proceeds used for purchasing tracts adjoining the nuclei of the three reservations.

THOSE interested in botany, whether or not they are special students of the science, are invited to become members of the Torrey Botanical Club, which meets twice monthly at the College of Pharmacy, 115 West 68th Street, New York. The program for the evening meetings of the Torrey Botanical Club during 1899 will include the following subjects:

Our Native Roses, by Dr. George N. Best.

A Comparison Between Geological Sequence and Biological Development in the Vegetable Kingdom, illustrated by lantern views, by Dr. Arthur Hollick.

Notes on the Flora of Santiago de Cuba, illustrated by lantern views, by Dr. Valery Havard, U. S. A.

Our Eastern Ferns, illustrated by lantern views, by Mrs. E. G. Britton and others.

The North American Blue-Eyed Grasses, by Mr. Eugene P. Bicknell.

The Adirondack Mountain Flora, by Mrs. Annie Morell Smith and others.

The Pine-Barren Flora of New Jersey, illustrated by lantern views, by Mr. Joseph Crawford and others.

Progress of Work on the New York Botanical Garden, illustrated, by Dr. N. L. Britton.

Sea-Weeds, illustrated by colored lantern slides, by Dr. C. C. Curtiss.

Cultivated Palms and their Cultivation, illustrated by living specimens, by Mr. H. A. Siebrecht.

The Spurges, by Mrs. Carolyn A. Creevy.

Evergreens, illustrated by lantern slides, by Mr. Samuel Henshaw.

Rocky Mountain Wild Flowers, illustrated by colored lantern slides, by Mr. Cornelius Van Brunt.

WE learn from *Natural Science* that the British Mycological Society held its second annual meeting in Dublin, September 19th-24th. Excursions were made to Howth, Powerscourt, Brackenstown near Swords, the woods of Avoca, Lucan and Dunran. These resulted in an addition of sixteen species to the fungus flora of Dublin and Wicklow; a list will appear in the December number of the *Irish Naturalist*. Dr. Plowright, President for the current year, delivered an address, discussing certain fungi figured in Cooke's 'Illustrations.' Papers were read by Messrs. Wager, Crossland, McWeeny, Soppitt and Rea.

M. THIBEAUT, Chargé d'Affaires of France, has notified Secretary Hay that the French government is about to adopt precautionary measures against the introduction from this country of the San José scale, and that decrees will be issued prohibiting the importation of trees, shrubs and plants from the United States and requiring an inspection of all fruits, fresh and dried, at the point of landing in France. The general trade from this country to France will suffer little through this step, as the shipment of trees, plants and shrubs last year aggregated only \$328 and those of fruit \$40,000. The action of France was taken, it is said, only after some of the American States had adopted precautionary laws against the pest referred to.

THE *British Medical Journal* states that the annual *conversazione* of the Röntgen Society was given by the President and Mrs. Mansell Moulton, at St. Martin's Town Hall, on Monday, November 21st. An inspection of the exhibits ranged round the hall emphasized the fact—which many who commence working at the X-rays very soon realize for themselves—that to make any advance in the knowledge of

Röntgen radiations is by no means an easy matter. The present state of knowledge and practice is certainly represented by the Röntgen Society, and the exhibits represented the utmost limits to which the process has been brought; yet, setting aside improvements in practical technique, the matter has not been pushed a step further than when Röntgen gave his remarkable discovery to the world. Mr. Mackenzie Davidson showed his beautiful method of localization of foreign bodies and some really practical applications of his stereoscopic radiographs. The same worker has also solved the difficulty of photographing stone in the kidney. This he does by the ingenious method of eliminating movements due to respiration by only exposing when a recording lever shows absolute rest of the abdominal parietes, the patient holding his breath the while. Professor Silvanus P. Thompson, F.R.S., demonstrated experiments with the Tesla oscillator, and Mr. Campbell Swinton showed a collection of tubes which he has used in his researches. There were many other exhibits too numerous to mention. The results which Mr. Wimbush has obtained with his influence machine are extremely good; the steadiness of the shadows given on a screen by twelve 20-inch plates is remarkable.

At a meeting of the Royal Geographical Society, London, on November 28th, Mr. Charles W. Andrews read a paper entitled 'A Description of Christmas Island (Indian Ocean).' Mr. Andrews said according to the report in the *London Times* that, as it seemed desirable that a more complete examination of the island should be undertaken than had up to that time been made, Sir John Murray, in 1896, generously offered to pay the expenses of an expedition. The lecturer left England to carry out the undertaking in May, 1897. He gave a detailed account of the physical features of the island, and said that its climate was delightful. During the greater part of the year it resembled a very hot English summer tempered with sea breezes. The island was perfectly healthy, there being no marshes or stagnant pools, while there was a fair supply of good water. The whole island was covered with forest, except the spray-swept edges of the sea cliff and the vertical faces of the inland cliffs. Many creepers

and ferns added to the beauty and variety of the forest scenery. The fauna was not a rich one. There were only five species of mammals, consisting of two kinds of rats, a shrew mouse and two bats. Rats swarmed everywhere and were very destructive. The reptiles were few and small. Insect life was fairly abundant. There were several species of land crabs, the most common being a little red crab living in burrows all over the island. The robber-crab was also very numerous, and if one sat down for a short time anywhere in the forest numbers could be seen approaching from all sides. They were good climbers and ascended trees in search of food. For some years Mr. Andrew Ross, brother of Mr. George Ross, the owner of Keeling Cocos Island, had been settled in Flying Fish Cove with his family and a few men from Cocos. During his stay some substantial houses had been built, well sunk, and fruit trees and cocoanut palms planted, and a small experimental plantation of coffee had also been made, the results showing that the island was well suited for coffee growing. In May last the total population was about 40.

#### UNIVERSITY AND EDUCATIONAL NEWS.

At a meeting of the Board of Governors of McGill University, on December 1st, Lord Strathcona announced his intention of endowing the new Victoria College for Women, which he built at a cost of \$250,000, to the amount of \$1,000,000. Mr. W. C. McDonald also announced that he intended to endow the chair of history in the arts faculty. At the dedication, on December 20th, of the new chemistry and surgery building of the University, given by Mr. McDonald, knighthood was conferred upon him.

It is expected that the New University of London will have its offices in the Imperial Institute, South Kensington, though it is possible that arrangements will be made to occupy the premises on Gower Street occupied by University College.

MR. AND MRS. L. LANSING ZABRISKIE have given \$500 to Wells College for the purchase of physical apparatus.

MR. E. F. HOLDEN has given \$6,000 to Syra-



cuse University, part of which has been used for the purchase of twenty-nine microscopes.

THE will of the late Miss Elizabeth Rogers leaves all her property, valued at \$100,000, to the Rogers Hall School for Girls at Lowell, Mass.

THE sum of \$50,000 has been collected in Pittsburg for the Methodist American University at Washington.

THE growth of the various English university colleges as compared with the older universities is illustrated by the papers read before the Royal Society during the past three years. Professor Ramsay points out that of 252 such papers about half—122—were contributed from these colleges, leaving only half from Oxford, Cambridge, Scottish and Irish universities and private individuals. University College, London, contributed 57 papers, which apparently surpasses the number of papers from Oxford or Cambridge.

THE Isaac Newton Studentship of Astronomy and the John Lucas Walker Studentship in Pathology at Cambridge University will be filled in January. Each studentship is of the annual value of £200 and is tenable for three years.

WE announced last week that Professor W. C. Röntgen had been called from Würzburg to Leipzig. The vacancy, we now learn, is caused by the retirement of Dr. Gustav Weidemann, which takes place at the end of the present semester.

DR. KLOCKMANN, of Clausthal, has been appointed professor of mineralogy and geology in the Institute of Technology at Aix.

M. C. SAUVAGEAU has been appointed professor of botany in the faculty of sciences at Dijon.

#### DISCUSSION AND CORRESPONDENCE.

##### ANLAGE OR PROTON?

TO THE EDITOR OF SCIENCE: I have read with interest the letter from Professor Burt G. Wilder which you recently published in regard to the word 'proton.' I thoroughly agree with him that it is very desirable to have some word better than *rudiment* for the primitive beginning in the embryo out of which some future struc-

ture is to be developed. We need a good word to use in our language, as the Germans use 'anlage' in theirs.

The suggestion of *proton* by Professor Wilder and that of 'primordium' by Professor Willey are certainly interesting, and I think, if we are to rely upon the Greek to supply us with a new term, that the suggestion made by Professor Wilder is the best we have had. But against all these suggestions I have to make an objection. It seems to me that the time has now definitely passed when it can be taken as a necessity for science to derive *all* technical terms from the Greek. When we look the matter fairly in the face we must recognize that the claim of superlative availability of Greek words and Greek derivatives is a survival of the Mediæval epoch, which was itself a survival of the earlier Roman days, when the Greek language was the language of the cultured, and the language with which all educated persons were not merely acquainted, but familiar. Whether or not this is a loss or gain, the Greek language is not now familiar to our generation; it is a language quite apart from the present day. The fact which we have to meet is that a knowledge of Greek is far from universal, and that a thorough knowledge of Greek is rarely attained except by the special student of the language. After all, a word is merely a convenient combination of sounds to furnish a symbol for a certain idea, and there is no inherent psychological reason why sounds of the type used by the Greeks should alone serve to represent ideas of a scientific character. Indeed, is it not striking that the greatest scientific nation of the world habitually uses technical terms of its own language—that German scientists use German words?

Now, Germany has attained such preeminence in science that it is probable that in any department at least as much is published in German as in any other two languages. It is literally impossible to keep abreast with any special department of science without a knowledge of German, and this implies an acquaintance with German words used by Germans with a technical meaning. An acquaintance with such words is absolutely indispensable.

To return to the question of an English equiv-

alent for 'anlage.' Why should we not use the German term? Why is not the German combination of sounds as scientific as any Greek combination? Why should we turn to Greek, a language far remote from English, out of which we must manufacture the word we want, rather than turn to the kindred language of German, which contains the precise word we want, a word, moreover, which every one must understand, if he wishes to study the science of embryology? Another important consideration is that the word 'anlage' has already been so widely and so extensively adopted both in England and America that it is now probably universally understood and often looked upon by those who use it as an accepted and established English word. Indeed, I believe its usage has become so thoroughly established that not only is the word indispensable, but also it has become impracticable to attempt to modify it; that the substitution of *proton* or *primordium* could not be accomplished, and that the attempt to make such substitution would only create an unfortunate conflict of terms. I hope, therefore, that these attempts and all similar ones will be renounced. It may also be described as a nuisance—this incessant introduction of superfluous scientific terms—and particularly in the form it takes of constantly adding a great many elaborate artificial words of Greek origin which are thoroughly unnecessary for scientific purposes. It would tend far more to the promotion of science to strike out altogether—so that they should be forever forgotten—half of the terms which have been introduced during the last twenty years, than to make any further additions to them. The load of unnecessary technical terms which we have to carry is a terrible impediment, which hinders our progress every day. I cannot but consider it the result of a pedantic superstition, which appears like a Moloch to whom the life of Science must pay a heavy sacrifice.

CHARLES SEDGWICK MINOT.

HARVARD MEDICAL SCHOOL,  
December 10, 1898.

IS THE BEACH PEA FOOD OR POISON?

CAN any botanical reader of SCIENCE give me any information in regard to the use as food

of the seeds of the common Beach Pea (*Lathyrus maritimus*)?

Some twenty years ago I was told a story of some children near Boston who were terribly poisoned from thoughtlessly eating these peas. In fact, my impression is that one or more of them were said to have died from the effects of the poison. Recently, however, in looking over the files of the 'Meddelelser om Grønland,' I came across the following note. In Lange's 'Conspetus floræ grænlantiæ,' under the heading *Lathyrus maritimus* (Med. om Grønland., Hefte 3, p. 233), the author writes as follows: 'Obs. Seminibus combustis ad coffeæ parandam utuntur Grænlanti,' quoting Wormskjöld as his authority. Of course, it is possible that roasting the peas to make coffee, neutralizes the poisonous principle if there be any. I should be glad of any further information on the subject, and, at all events, wish especially to call attention to this curious substitute for coffee.

JOHN MURDOCH.

PUBLIC LIBRARY, BOSTON.

[We are informed by Mr. V. K. Chesnut that the seed of the beach pea, *Lathyrus maritimus*, is eaten while still green in a number of places, including England, parts of Alaska, Kamchatka and the Island of Yeso. No recorded cases of poisoning from this species are known to him, but a peculiar kind of poisoning is caused by eating the seeds of other species of *Lathyrus* for long periods at a time. It is a curious disease which at one time and another has been very prevalent in India. Horses have recently been killed there by eating imported seeds of some of the vetches. It seems possible, therefore, that some toxic principle may be present in the beach pea. The question might be settled if a series of experiments were made on guinea pigs.—EDITOR SCIENCE.]

SCIENTIFIC LITERATURE.

*Encyclopædie der mathematischen Wissenschaften.*

Mit Unterstützung der Akademien der Wissenschaften zu München und Wien und der Gesellschaft der Wissenschaften zu Göttingen.

gen, herausgegeben von H. BURKHARDT und W. F. MEYER. Leipzig, Teubner. 1898. Band I. Heft 1. Pp. 112.

This is an undertaking of extraordinary importance and promise.

Its aim is to give a consecutive presentation of the assured results of the mathematical sciences in their present form, while, by careful and copious references to the literature, giving full indications regarding the historic development of mathematical methods since the beginning of the nineteenth century. The work begins with twenty-seven pages on the foundations of arithmetic by Hermann Schubert, of Hamburg. Schubert's reputation was made by his remarkable book on enumerative geometry. He has since applied the modern ideas in an elementary arithmetic, and is known in America as a contributor to the *Monist*.

Unfortunately Schubert has made in public some strange slips. In an article, 'On the nature of mathematical knowledge,' in the *Monist*, Vol. 6, p. 295, he says: "Let me recall the controversy which has been waged in this century regarding the eleventh axiom of Euclid, that only one line can be drawn through a point parallel to another straight line. The discussion merely touched the question whether the axiom was capable of demonstration solely by means of the other propositions or whether it was not a special property, apprehensible only by sense-experience, of that space of three dimensions in which the organic world has been produced, and which, therefore, is of all others alone within the reach of our powers of representation. The truth of the last supposition affects in no respect the correctness of the axiom, but simply assigns to it, in an epistemological regard, a different status from what it would have if it were demonstrable, as was one time thought, without the aid of the senses, and solely by the other propositions of mathematics."

If Schubert had written this seventy-five years ago it might have been pardonable. Just at the beginning of this century Gauss was trying to prove this Euclidean parallel-postulate. Even up to 1824 he was in Schubert's state of mind, for he then writes Taurinus: "Ich habe daher wohl zuweilen *im Scherz* den Wunsch geäußert,

dass die Euclidische Geometrie nicht die Wahre wäre."

But the joke had even then gone out of the matter if Gauss had but known it, for in 1823 Bolyai Janos had written to his father: "From nothing I have created a wholly new world."

Of the geometry of this world as given also by Lobachévski, Clifford wrote: "It is quite simple, merely Euclid without the vicious assumption."

But this assumption is only vicious if supposed to be 'apprehensible by sense-experience' or 'demonstrable by the aid of the senses.'

That 'the organic world has been produced' in Euclidean space can never be demonstrated in any way whatsoever. On the other hand, the mechanics of actual bodies might be shown by merely approximate methods to be non-Euclidean. Therefore, Schubert's contribution on the foundations of arithmetic may fairly be read critically. He begins with counting, and defines number as the result of counting. This is in accord with the theory that their laws alone define mathematical operations, and the operations define the various kinds of number as their symbolic outcome.

There is no word of the primitive number-idea, which is essentially prior to counting and necessary to explain the cause and aim of counting. This primitive number-idea is a creation of the human mind, for it only pertains to certain other creations of the human mind which I call artificial individuals. The world we consciously perceive, is a mental phenomenon. Yet certain separable or distinct things or primitive individuals, we cannot well help believing to subsist somehow 'in nature' as well as in conscious perception. Now, by taking together certain of these permanently distinct things or natural individuals, the human mind makes an artificial individual, a conceptual unity.

Number is primarily a quality of such an artificial individual.

The operation of counting was made to apply to such an individual to identify it with one of a standard set of such artificial individuals, and so to get the exact shade of its numeric quality. These standard individuals were primarily sets of fingers. Then came the written



standard set, *e. g.*, III., or  $1+1+1$ ; and finally the written symbol, 3. Such symbols serve to represent and convey the numeric quality. The word 'number' is applied indiscriminately to the quality or idea and to its symbol.

Schubert tells us that in antiquity the Romans represented the numbers from one to nine by rows of strokes, as 4 is still represented on our watches; while the Aztecs used to put together single circles for the numbers from one to nineteen. I have seen Japanese use columns of circles in the same way. Thus, also, our striking clocks convey a numeric quality by a group possessing it. But the number pertaining to a group or artificial individual is far from being the simple notion it seems. If numbers are used to express exactly this definite attribute of finite systems they are called cardinal numbers.

Schubert's first sentence is: "Dinge zählen heisst, sie als gleichartig ansehen, zusammen auffassen, und ihnen einzeln andere Dinge zuordnen, die man auch als gleichartig ansieht." This may be rendered: "To count things means to consider them as alike, to take them together, and to associate them singly to other things which one also considers as alike." I would prefer to say: "To count distinct things means to make of them an artificial individual or group, and then to identify its elements with those of a familiar group." When the mind of man made these artificial individuals they were found to possess a sort of property or quality which was independent of the distinctive marks of the natural individuals composing them, also independent of the order or sub-association of these natural individuals. Whether the artificial individual were made of a church, a noise and a pain, or made of three peas, or composed of two eyes and a nose, it had one certain quality—it was a triplet.

I see no necessity for Schubert to consider the church as like the noise and the pain. Again, the individuals of the familiar group used in the count need not be alike. Even the individuals used by a clock in counting differ ordinally, and when we follow the count of the clock we use words all different. The primitive written number is such a picture of a group of individuals as represents their individual existence and nothing more, *e. g.*, III.; so, however different

they may be, this number is independent of the order in which they are associated with its elements.

Schubert wastes three sentences on the so-called concrete number, *benannte Zahl*. Three quails is not a number, but is a particular bevy. His Section 2, *Addition*, he begins thus: "If one has two groups of units such that not only all units of each group are alike, but that also each unit of the one group is like each unit of the other group," etc. All this likeness and alikeness seems unnecessary. Any two groups may be thought into one group. Any two primitive numbers may be added.

In Section 5, Peacock's Principle of Permanence is given in Hankel's general form: The combination of two numbers by any defined operation is a number, such that the combination may be handled as if it gave one of the previously defined numbers. New kinds of numbers, like all numbers, are defied by the operations from which they result. Thus are introduced zero and negative numbers, and later the fraction. After this all is easy to the end of Schubert's contribution.

It only remains to point out, as of especial importance, that from beginning to end not the slightest mention is made of measurement. Not a word is wasted on people who do not clearly see that number is long prior to measurement.

The second section of the *Encyklopaedie* is 'Kombinatorik,' by E. Netto. This is a part of mathematics which never fulfilled the hopes of the school which was lost in it during the early part of this century. Of the most comprehensive monographs the last two are in 1826 and 1837. For us it has gone over into determinants, and more than half of Netto's article is devoted to determinants. This article is particularly valuable from a bibliographic and historic point of view.

The third section is 'Irrationalzahlen und Konvergenz unendlicher Prozesse,' by A. Pringsheim. It begins on page 47, and goes past the end of the Hef. This is a modern subject, of intense living interest. How entirely modern it is might not be suspected by readers of such sentences in Cajori's excellent history of mathematics as those on page 70: "The first incommensurable ratio known seems to have been

that of the side of a square to its diagonal, as 1 :  $\sqrt{2}$ . Theodorus of Cyrene added to this the fact that the sides of squares represented in length by  $\sqrt{3}$ ,  $\sqrt{5}$ , etc., up to  $\sqrt{17}$ , and Theætetus, that the sides of any square, represented by a surd, are incommensurable with the linear unit." Now in fact Theodorus and Theætetus made no representation whatever of the length of these sides, simply saying, *e. g.*, that the side of the square whose area is 3 is incommensurable with the side of the square whose area is one. For Euclid there was no such ratio as 1 :  $\sqrt{2}$ ; for 1 is a number and so if it could have had a ratio to  $\sqrt{2}$  this would have been a number. But Euclid, Book X., Proposition 7 is: "Incommensurable magnitudes are not to one another in the ratio of one number to another number."

The Hindus were the first to recognize the existence of irrational numbers. Even through the Middle Ages and the Renaissance they were absurd fictions, 'numeri surdi,' a designation attributed to Leonardo of Pisa. The first writer to treat them genuinely was Stifel (1544), and even he had not completely freed himself from the older terminology, since he says: "sic irrationalis numerus non est verus numerus atque lateat sub quadam infinitatis nebula."

In reference to the next step, the conceiving of ratio as number, Pringsheim says, page 51: "Hatte schon Descartes beliebige Streckenverhältnisse mit einfachen Buchstaben bezeichnet, und damit wie mit Zahlen gerechnet," etc. But here I think the careful German has slipped.

In regard to just this point a common error is still widespread, which we see in the following, read before Sections A and B of the American Association for the Advancement of Science, 1891:

"The doctrine of Descartes was that the algebraic symbol did not represent a concrete magnitude, but a mere number or ratio, expressing the relation of the magnitude to some unit. Hence that the product of two quantities is the product of ratios, \* \* \* ; that the powers of a quantity are ratios like the quantity itself," etc.

That every statement here quoted is a mistake will be instantly seen from the following, taken from pages numbered 297-9 of the *original edition* of Descartes' *Geometrie*, 1637, a copy of

which (perhaps unique on this continent) I have had the good fortune to possess since my student days (1876).

"Et comme toute l'Arithmetique n'est composée, que de quatre ou cinq operations, que sont l'Addition, la Soustraction, la Multiplication, la Division, & l'Extraction des racines, qu'on peut prendre pour vne espece de Division : Ainsi n'at' on autre chose a faire en Geometrie touchant les lignes qu'on cherche, pour les preparer a estre connues, que leur en adjoüster d'autres, ou en oster; Oubien en ayant vne, que ie nommeray l'vñité pour la rapporter d'autant mieux aux nombres, & qui peut ordinairement estre prise a discretion, puis en ayant encore deux autres, en trouver vne quatriesme, qui soit a l'vne de ces deux, comme l'autre est a l'vñité, ce qui est le mesme que la Multiplication; ou bien en trouver vne quatriesme, qui soit a l'vne de ces deux, comme l'vñité est a l'autre, ce qui est le mesme que la Division; ou enfin trouver vne, ou deux, ou plusieurs moyennes proportionnelles entre l'vñité, & quelque autre ligne; ce qui est le mesme que tirer la racine quarrée, ou cubique, &c. Et ie ne craindray pas d'introduire ces termes d'Arithmetique en la Geometrie, afin de me rendre plus intelligible. \* \* \*

"Mais souuent on n'a pas l'esioin de tracer ainsi ces lignes sur le papier, & il suffit de les designer par quelques lettres, chacune par vne seule. Comme pour adjoüster la ligne BD a GH, ie nomme l'vne *a* & l'autre *b*, & escrie  $a + b$ ; Et  $a - b$ , pour soustraire *b* d' *a*; Et  $ab$ , pour les multiplier l'vne par l'autre; Et  $\frac{a}{b}$ , pour diuiser *a* par *b*; Et  $aa$ , ou  $a^2$ , pour multiplier *a* par soy mesme; Et  $a^3$ , pour le multiplier encore vne fois par *a*, & ainsi a l'infini; Et  $\sqrt{a^2 + b^2}$ , pour tirer la racine quarrée d'  $a^2 + b^2$ ; Et  $\sqrt[3]{C. a^3 - b^3 + abb}$ , pour tirer la racine cubique d'  $a^3 - b^3 + abb$ , & ainsi des autres.

"Ou il est a remarquer que par  $a^2$  ou  $b^3$  ou semblables, ie ne conçois ordinairement que des lignes toutes simples, encore que pour me seruir des noms vsités en l'Algebre, ie les nomme des quarrés, ou des cubes, &c."

Thus what Descartes really did was to make a geometric algebra, in which, however, the product of two *sects* (Strecken) was not a rectangle but a sect; the product of three sects not a cuboid but a sect. Here Descartes represents by the single letters *a*, *b*, sects, Strecken, not Streckenverhältnisse. Descartes does not here pass beyond Euclid's representation of the ratio of two magnitudes by two other magnitudes, does not reach the conception of the systematic representation of the ratio of two magnitudes

by one magnitude, that one magnitude to be always interpreted as a number. This radical innovation, the creation of this epoch-marking paradox, is due to Newton. Newton takes this vast step explicitly and consciously. The lectures which he delivered as Lucasian Professor at Cambridge were published under the title, 'Arithmetica Universalis.' At the beginning of his *Arithmetica Universalis* he says, page 2: "Per Numerum non tam multitudinem unitatum quam abstractam quantitatis cujusvis ad aliam ejusdem generis quantitatem quae pro unitate habetur rationem intelligimus." [In quoting this, Pringsheim, p. 51, misses the first word. He omits the *Per*.]

As Wolf puts it (1710): "Number is that which is to unity as a piece of a straight line [a sect] is to a certain other sect." Thus the length of any sect is a real number, and the length of any possible sect incommensurable with the unit sect is an irrational number.

Says Hayward in his *Vector Algebra* (1892), page 5: "Number is essentially *discrete* or *discontinuous*, proceeding from one value to the next by a finite increment or jump, and so cannot, except in the way of a limit, represent, relatively to a given unit, a continuous magnitude for which the passage from one value to another may always be conceived as a *growth* through every intermediate value."

But the moment we accept Newton's definition of number it takes on whatever continuity is possessed by the sect. However, from this alone does not follow that for every irrational there is a sect whose length would give that irrational. G. Cantor was the first to bring out sharply that this is neither self-evident nor demonstrable, but involves an essential pure geometric assumption.

To free the foundations of general arithmetic from such *geometric* assumption, G. Cantor and Dedekind each developed his pure arithmetic theory of the irrational.

Professor Fine, in his 'Number-System of Algebra,' seems to miss this point completely. He gives, page 42, what purports to be a demonstration that "corresponding to every real number is a point on the line, the distance of which from the null-point is represented by the number," without any mention of the geometric

assumption necessary, and then proceeds, page 43, to borrow the continuity of his number system from the naïvely supposed continuity of the line, the very thing for the avoidance of which G. Cantor and Dedekind made their systems.

Says Dedekind. "Um so schöner erscheint es mir, dass der Mensch ohne jede Vorstellung von messbaren Grössen, und zwar durch ein endliches System einfacher Denkschritte sich zur Schöpfung des reinen, stetigen Zahlenreiches aufschwingen kann; und erst mit diesem Hilfsmittel wird es ihm nach meiner Ansicht möglich, die Vorstellung von stetigen Raume zu einer deutlichen auszubilden."

GEORGE BRUCE HALSTED.

AUSTIN, TEXAS.

*The Tides and Kindred Phenomena in the Solar System.* By GEORGE HOWARD DARWIN. Boston and New York, Houghton, Mifflin & Co. 1898. Pp. xviii + 378.

During October and November, 1897, Professor Darwin delivered a course of semi-popular lectures on tidal phenomena at the Lowell Institute, Boston, Massachusetts. Since then the author has prepared these lectures for the press, and they are now, through the enterprise of Messrs. Houghton, Mifflin & Co., placed before the reading public in attractive book form.

The salient features of oceanic tides are more or less familiar to most people in these days. Indeed, some intelligent people will tell us that it is only necessary to read the daily papers of the seaboard towns, or to look in 'The Farmers' Almanac,' to learn when high and low water will occur. The educated public was not always so well informed, however. When, for example, Alexander the Great attempted to make a landing at the mouth of the Indus his fleet was nearly overwhelmed by the inrush of the tide. "The nature of the ocean," according to his biographer, Curtius, "was unknown to the multitude, and grave portents and evidences of the wrath of the gods were seen in what happened.!" The admirals of the present day know more about tides than the admiral of Alexander, and the wrath of a court of enquiry, rather than the wrath of the gods, hangs over the head of any commander who exposes his fleet to tidal dangers. But whence comes



the knowledge that enables us to anticipate the rise and fall of the ocean? How are the tidal tables of the daily papers and of 'The Farmers' Almanac' constructed?

It was the primary object of the lectures of Professor Darwin to answer such questions; to explain in a popular way, without the aid of mathematical and physical technicalities, how, from observations of the tides and from the modern theory thereof, predictions of the rise and fall of the ocean at any port may be issued years in advance. In addition to these more obvious tidal phenomena he has also discussed the more recondite phenomena of bodily tides in the earth and other members of the solar system. Thus, from questions of commercial or otherwise purely practical significance, the reader is led up to questions in cosmology of the highest scientific importance, especially in their bearings on the remote history, past and future, of our planet.

The task which Professor Darwin set for himself was a difficult one. Few, if any, questions in the mathematico-physical sciences are more profoundly complicated than those presented by tidal phenomena. Their elucidation has taxed the ingenuity of the most laborious investigators from the time of Newton to the present day. In the highly condensed language of mechanics it may be said that these phenomena, in any case, are simply the outcome of the energy, the angular momentum and the friction involved. But to turn conclusions expressed in such language into common parlance would seem to be almost as great a work as that of reaching the conclusions themselves. No one less well equipped than Professor Darwin would have dared to undertake this task. Thoroughly familiar with the details of tidal action, and himself a principal contributor to recent advances in tidal theories, he has produced a charmingly interesting and instructive book, which may be read with profit by those who know much as well as by those who know little of the tides.

The book is divided into twenty chapters under the following titles: Tides and Methods of Observation, Seiches in Lakes, Tides in Rivers—Tide Mills, Historical Sketch, Tide-generating Force, Deflection of the Vertical,

The Elastic Distortion of the Earth's Surface by varying Loads, Equilibrium Theory of Tides, Dynamical Theory of the Tide Wave, Tides in Lakes—Cotidal Chart, Harmonic Analysis of the Tide, Reduction of Tidal Observations, Tide Tables, The Degree of Accuracy of Tidal Prediction, Chandler's Nutation—The Rigidity of the Earth, Tidal Friction, Tidal Friction (continued), The Figures of Equilibrium of a Rotating Mass of Liquid, The Evolution of Celestial Systems, Saturn's Rings. Each chapter is followed by a list of authorities on the subject of the chapter, and a good index completes the volume.

R. S. W.

*The Elements of Physics.* By ALFRED PAYSON GAGE. Boston, Ginn & Co. 1898. 12mo. Pp. x+381.

The author of this book put forth his first edition sixteen years ago and has long been favorably known as a reliable authority in the school room. The motto then adopted, 'Read Nature in the Language of Experiment,' is very properly retained in the present volume, which is not a revision, but a new book differing quite radically from the first in its method of presentation. The change, moreover, is a great improvement. We all agree that the experimental method is the proper method of investigating what is collectively called Nature, but there has been much difference of opinion about the advisability of regarding elementary pupils in the high school as fit to acquire their fundamental conceptions of physics by independent discovery. In the preface to the present volume Dr. Gage repeats the expression of his belief in the importance of the laboratory method in the high school, but adds that he has 'observed the development of a tendency which threatens seriously to impair its usefulness.' He is now 'convinced that both mental discipline and the acquisition of knowledge will be promoted if theory and experiment be somewhat sharply divided.'

There are a good many of us who have long held this last view in opposition to that which was carried out in Dr. Gage's first book. The demand for laboratory methods in the school room is much more than sixteen years old. A protest against the abuse of them was distinctly

formulated by Dr. Mendenhall in his vice-presidential address delivered before the Section of Physics at the Montreal meeting of the American Association for the Advancement of Science in 1882, the very year when Dr. Gage's book appeared. It is probably safe to say that a majority of American teachers of physics are now agreed in the view that the elementary pupil should not enter the laboratory as an original investigator, because he is utterly unfit to be such until after much training has been received. What he needs is a well arranged, clear and accurate presentation of principles, with such experimental demonstrations by the teacher as may be needed to ensure the acquisition of the truth. After a good introduction has thus been received he should have the opportunity to make a selected series of tests of these principles in the laboratory, and advantage should be taken of such practice to train him into habits of close observation, system, neatness and good order. He needs, therefore: first, a reliable class text-book, the study of which should accompany the teacher's lectures; and, second, a separate laboratory manual, or its equivalent in the form of special written or printed instruction cards adapted to the particular apparatus that is put into his hands after the requisite class-room preparation has been secured. Should he in time manifest enough originality to become an investigator, his work will probably be amid surroundings better adapted for research than the school laboratory.

It is to meet the first of these needs, a reliable class text-book, that the present volume has been written. The author exhibits good judgment, not only in the selection of what he includes, but in omitting certain special topics, such as the polarization of light, of which a smattering is often unwisely given. Such subjects as absorption, osmose and crystallization belong now to the newly differentiated science of physical chemistry. Nevertheless, there remain some embarrassments due to the necessity to avoid mathematics, and the attempt to be a trifle too conservative by recognizing certain details of nomenclature that are deservedly passing away. For example, the poundal is recognized as a unit of force. The only excuse for the inven-

tion of such a unit has been to bring the clumsy 'British' system into accordance with the far simpler system, employed by all physicists irrespective of nationality, that for the sake of contrast is often called the absolute system. Engineers in England and America express weights in pounds, but they have no use for poundals in either theory or practice. The physicist thinks in the simpler system, but often has to translate his final results into the British system. There is hence no use in befogging the minds of young pupils with more than one unit of force, the dyne. Nor is any advantage to be derived from specifying two methods of measuring force, calling one the statical or gravitational system, and the other the dynamical or absolute system. The latter is the only one needed; the former is always expressible in terms of the absolute system. The suggestion of duality is confusing and often misleading. The confusion culminates where the pupil is confronted with poundal, foot-poundal, pound, foot-pound, dyne, erg, gram, gram-centimeter and kilogram, all grouped in a single diagram (p. 71) for the purpose of contrasting the units of force and of work. If all calculations are made in terms of centimeters and grams there is but little trouble in translating final results if necessary.

The author in similar manner speaks of density, specific density and specific gravity. Of these three terms the first is the only one that is really needful, though it may sometimes be convenient to employ the term specific gravity, or relative density, to denote that a secondary rather than primary standard is employed. The distinction between specific density and specific gravity is, of course, definable, but in the interest of simplicity it is not desirable.

In illustrating any subject with numerical examples it is best to employ such as are approximately within the range of practice. After a good description of Joule's apparatus for the determination of the mechanical equivalent of heat, which was operated in Joule's laboratory, an example is given in which the weights are supposed to be raised to a height exceeding that of an ordinary church steeple. There is, of course, no theoretical objection to this. But it is practically of some importance that the final

result should be given in the corrected form which was accepted by Joule after Rowland's exhaustive experiments in Baltimore. Joule's equivalent is now quite generally quoted as 427 rather than 424 kilogram-meters at ordinary laboratory temperature.

The difficulty of conveying clear ideas without mathematical regards india-rubber, a highly compressible solid, as the type of elasticity, while in reality its modulus of elasticity is exceptionally small. The stretch modulus is defined in an appendix to the present volume; but it is not concerned in the propagation of a sound wave through air, and it is in this connection that the formula is given. To account for the high velocity of sound in solids and liquids by reference to their superior incompressibility is inadequate unless the relation between compressibility and the volume modulus of elasticity has been already made plain. The elementary student has scarcely any alternative but to memorize words in this connection, and to trust to the future for the ideas they are intended to convey, however faithful the author of the text-book may have been to put into English what is always beyond the youthful reader.

The presentation of the subject of electric potential is unusually well given; it is, indeed, as good as could possibly be expected without mathematics. The general treatment of electricity is clear and up to date, several pages being devoted to X-rays and the phenomena of alternating currents of high potential and high frequency.

The book is not free from typographical errors, but these are in no case serious. There are occasional statements of minor importance to which exception may be taken, but the author is generally accurate and reliable, and his skill in the art of presentation is unquestioned. Among the welcome features are woodcut reproductions of the portraits of Archimedes,

Galileo, Newton, Franklin, Faraday and Lord Kelvin.

W. LE CONTE STEVENS.  
WASHINGTON AND LEE UNIVERSITY,  
LEXINGTON, VA.

*Leçons de chimie physique.* Professées à L'Université de Berlin. Par J. H. VAN'T HOFF, Membre de l'Académie des Sciences de Berlin, Professeur ordinaire à L'Université, et Directeur de L'institut de Physique de Charlottenburg. Translated from the German by M. CORVISY, Professeur agrégé au Lycée de Saint-Omer. Première partie. *La Dynamique Chimique.* Librairie Scientifique. Paris, A. Hermann. 1898.

This work, as the title implies, is a translation of Van't Hoff's 'Vorlesungen über theoretische und physikalische Chemie,' or of that part of it which has thus far appeared—Chemical Dynamics. The book, as the author states, "is based upon the lectures which I give at the University of Berlin, on 'Selected Chapters in Physical Chemistry.' Indeed, it contains more than these lectures, since, in the limited time at my disposal, I was able to take up only some of the more important points, in order to cover the entire field in one lecture a week during four semesters." The method of treatment is that adopted by Lothar Meyer in the later editions of his 'Modern Theories of Chemistry.' The whole subject is treated under the general heads of Statics and Dynamics; Statics dealing with homogeneous substances, with views as to the structure of matter, with the molecular and atomic conception, and with the determination of constitution; Dynamics, with the reciprocal transformation of several substances, with affinity, reaction, velocity and chemical equilibrium. A third part is added, on the relation between physical and chemical properties and composition.

The order is, however, reversed. Chemical Dynamics, having been placed on a surer basis by thermodynamics, has acquired greater prominence, and is dealt with at the beginning. We have then: First, *Chemical Dynamics*; second, *Chemical Statics*, and third, *Relations between Properties and Composition*.

The advantage of this order is that in the first part of the work only the molecular conception enters, while the atomic hypothesis and the problem of configuration do not appear



until the second, and the problem of the relations of substance to substance, about which we still know very little, is relegated to the third and last division.

The first part, or chemical dynamics, which is now available in German and in French, treats the subject under the two general heads of *Chemical Equilibrium* and *Reaction Velocity*. We have the physical and chemical equilibria in a homogeneous substance, between two substances, between three substances, between four substances; chemical equilibrium from the molecular-mechanical standpoint; homogeneous and heterogeneous equilibria; the law of reaction velocity; reaction velocity and equilibrium; reaction velocity and affinity; mono-, bi- and tri-molecular reactions; effect of the surroundings and medium on reaction velocity; effect of temperature on the reaction velocity; effect of pressure on the reaction velocity.

The translation of this, a part of Van't Hoff's work, before the appearance of the remainder, is indicative of that esteem in which he is so justly held, not only at home, but in foreign lands. The translation into French seems to have been very carefully done, and the French edition is an inviting one, barring an occasional typographical error.

It is a matter of delight to all who are interested in physical chemistry that books are appearing simultaneously on the same chapter of their subject, from the pens of two of the great leaders in this field of work. As is well known, that portion of Ostwald's *Lehrbuch* which deals with the broad subject of *Verwandtschaftslehre* is now available in part. These two works admirably illustrate the difference in method of these two master minds, and each is enhanced in value by the other.

HARRY C. JONES.

*Laboratory Directions for Beginners in Bacteriology.* By VERANUS A. MOORE.

This book of ninety pages contains the outlines of an introductory laboratory course divided into sixty lessons, and aims to impart a technical and working knowledge of the more essential bacteriological methods and to develop a definite knowledge of a few important species of bacteria. The book is not intended to

replace the text-book on bacteriology, but to be a manual for use at the laboratory desk in which through a series of carefully selected exercises the student, without waste of time, will cover the necessary ground.

A manual such as this represents strongly in its selections and in the amount of time allotted to each subject the personal opinions of its author, yet we believe on the whole the judgment of the writer will be approved by teachers.

This book will be found very useful by teachers who have not the time to prepare and print their own outlines. Even those who are compelled to give a course much shorter than that sketched in this book can easily, without serious harm, reduce the length of the course by omitting the practical work in some of the chapters and shortening it in others. The classification of the bacteria upon the system of Migula seems to us a mistake, for it necessitates many changes in the accustomed nomenclature; thus the name bacillus is limited to motile rod-shaped organisms to which the flagella are attached to all parts of the body. A bacillus with polar flagella becomes a pseudo-monas and one without any flagella a bacterium. As this book is intended to be used along with various text-books on bacteriology, it would seem wiser to have omitted any elaborate and unusual classification which, however valuable, must of necessity frequently clash with that used in the text-book, and thus tend to confuse the student.

WM. H. PARK.

#### GENERAL.

THE U. S. Department of Agriculture has issued a bulletin on Fish as Food (*Farmers' Bulletin*, No. 85), by Dr. C. F. Langworthy, of the Office of Experiment Stations, in which the results of investigations on the nutritive value of various kinds of sea food have been summed up for the general reader. The chemical composition of a considerable number of fresh and preserved fishes, mollusks, crustaceans, etc., are given; the relative cost of protein and energy in fish and other food material is shown; the place of fish in the diet is discussed, and some sample menus are given to show how fish may be combined with other food materials to make a well-balanced dietary. The popular notion

that fish is a 'brain food' is combatted, but it is stated that 'most physiologists regard fish as a particularly desirable food for persons of sedentary habits.'

THE second and third volumes of Jordan and Evermann's 'Synopsis of the Fishes of North and Middle America' have appeared, but the volume of illustrations, it is understood, may be delayed for some months. When the last volume is published, a review may be expected in SCIENCE.

THE new 'Life of Michael Faraday,' by Professor Sylvanus Thompson, which Messrs. Cassell & Co. will publish shortly, contains, says *Literature*, many points that have not appeared in any earlier biography. Several hitherto unpublished letters and a poem by Faraday himself are included, as well as a number of extracts from his laboratory note-books, from which also some sketches of apparatus are reproduced in facsimile. Fresh light is thrown upon Faraday's refusal, in 1836, of the pension offered him by Lord Melbourne.

#### SCIENTIFIC JOURNALS.

THE *American Naturalist* for December opens with an article by Mr. L. P. Gratacap of the American Museum of Natural History on the Relations of James Hall to American Geology and a portrait of Dr. Hall is given as a frontispiece. The work on the Wings of Insects by Professor Comstock and Dr. Needham is continued. Professor J. L. Howe contributes an interesting article on variation in the shell of *Helix Nemoralis* in the Lexington (Virginia) colony. Mr. H. H. Field describes the work of the *Concilium Bibliographicum*. He states that it has been conducted at a considerable loss, but that its future is now assured by the subsidy voted to it by the Swiss Confederation, the Canton and the town of Zurich. It is said that, while South America and Hawaii have ordered several complete sets of the cards, there is only one such set in New England. The last article of the number is by Mr. O. P. Hay on 'Protostega, the systematic position of Dermochelys, and the morphogeny of the Chelonian Carapace and Plastron.' We regret to see that Dr. Robert P. Bigelow feels compelled to resign his position

as editor-in-chief of the *Naturalist*, as he is unable to devote to it the large amount of time required for its management.

THE *American Geologist*, for December, contains the following articles: 'On the Dikes in the Vicinity of Portland, Maine,' E. C. E. Lord; 'Thomsonite and Lintonite from the North Shore of Lake Superior,' N. H. Winchell; 'Primitive Man in the Somme Valley,' Warren Upham; 'The Great Terrace of the Columbia and other Topographic Features in the Neighborhood of Lake Chelan, Washington,' Israel C. Russell; 'The Occurrence of Cretaceous Fossils in the Eocene of Maryland,' Rufus Mather Bagg, Jr.

THE *Biologische Centralblatt* issued on October 27, 1898, contains a memorial notice of the late Professor Theodore Eimer by his former assistant, Gräfin Dr. Maria von Linden. It may be remembered that Dr. von Linden contributed to this JOURNAL (Vol. IV., p. 308) an account of Eimer's work in certain directions.

WE have received the first number of the *L'Intermédiaire des neurologistes et des aliénistes*, edited by the competent neurologist, M. Paul Sollier, and published by M. Felix Alcan, Paris. A most curious feature of the journal is the publication of its contents in French, German and English versions, a plan that would scarcely occur to a German or an Englishman. It is no wonder that under these conditions the editor asks that, considering the space required by 'the threefold texte,' correspondents are requested to write 'in the most possible short manner.' It would, we feel sure, be interesting to quote in full the editorial introduction, but we have only space for the concluding sentences: "The interest of informations taken and given, the pleasure of exposing personal opinions on subjects of high importance with the hope of being useful to others equally interested to them will, I hope, be sufficient movus to permit us to expect a collaboration which will find us very grateful. It will depend of them to whom we address that this organ, modest at its beginnings, should take, in the course of time, more and more importance and more extent, and we pray for some credit before any judgment."

## SOCIETIES AND ACADEMIES.

ENTOMOLOGICAL SOCIETY OF WASHINGTON,  
DECEMBER 1, 1898.

UNDER the head of election of officers all of the officers serving during 1898 were re-elected for the year 1899. E. Dwight Sanderson, of College Park, Maryland, was elected an active member.

Under the head of exhibition of specimens and short notes, Mr. Schwarz spoke of the Scolytidæ of Arizona, showing that thirty two species had been collected in southern Arizona by Mr. Hubbard and himself. Nineteen of these species occurred in the pine region; seven in the oak zone, and six in the lowest region. Of the whole number, only ten species proved to be identical with previously described forms, and all but one of the identified species belong to the pine regions.

Dr. A. D. Hopkins, by invitation of the Chair, presented some notes on Scolytidæ with especial reference to habits. He showed the male of *Hypothenomus*, which is relatively of extremely small size and is rare. *H. dissimilis* breeds in dead twigs where the larvæ consume a kind of ambrosia. In the first lot of eggs deposited only one is a male and this apparently is the only male in the number of successive broods developed as a product of a single female. There is, therefore, intense polygamy and in-and-in breeding. Further notes were given on the habits of *Cnesinus strigicollis* and *Pityophthorus minutissimus*. He showed that the larvæ of Scolytids are sometimes killed by not very severe freezing, from which he considered that the remarkable disappearance of *Dendroctonus frontalis* in 1893 was due to the severe freeze of 1892-93. He mentioned a stridulating sound made by *Dendroctonus terebrans* by rubbing the dorsal margin of the last abdominal segment against the inner surface of the elytra near the tips. He recorded the finding of *Dendroctonus simplex* breeding in the American larch in West Virginia at an elevation of 2,600 feet, and concludes that *D. simplex* may yet prove to be distinct from *D. rufipennis*. He further presented some interesting notes on the insect enemies of Scolytidæ.

This communication was discussed by Messrs. Schwarz, Howard, Ashmead and Johnson.

Mr. Ashmead stated that all of the European parasites of *Scolytus rugulosus* have now been found in the United States, the first one, *Chiropachys colon*, having been recognized 20 years ago by Mr. Howard.

Mr. Johnson stated that he had studied *Scolytus rugulosus* in the orchards of Maryland during the past few years. He found that it attacked plums and peaches with great virulence, but he had always noticed that the trees thus attacked had always been damaged in some way either by being barked in process of cultivation or by a branch being broken, or by some unknown cause. He had seen the *Chiropachys colon* in considerable numbers and had observed a curious habit in this insect in that both male and female when about to mate posture before each other vibrating the wings. One orchard of about 600 trees of the Satsuma plum had been extensively infested by *S. rugulosus*. The trees had died from some perfectly obscure cause which neither he nor Mr. Woods, of the Division of Vegetable Pathology, had been able to ascertain, and were immediately attacked in great numbers by the Scolytids.

Dr. Hopkins stated that this beetle will attack for food the buds of perfectly healthy trees, and in this way bring about so great an injury as to induce a breeding attack of the same insect.

This statement was confirmed by Mr. Schwarz, who said that in his opinion the insects of the genus *Scolytus* will attack perfectly healthy trees. He instanced the *Scolytus quadrispinosus* on perfectly healthy hickory trees at Detroit, Mich. These were old but perfectly healthy trees and they were not appreciably damaged by the insect. At Mt. Airy, Ga., he had seen an apparently perfectly healthy peach tree suddenly attacked by this insect for feeding purposes. The feeding punctures can always be distinguished from breeding punctures by the fact that they occur in circular rows.

Mr. Johnson stated that very few of us are able to ascertain what is a perfectly healthy tree, and that he was certain that in his experience some injury, however obscure, preceded attack by this insect.

Mr. Ashmead spoke of and illustrated by diagrams some important structural characters in the Crabronidæ. He had recently devoted



some weeks' study to the insects of this family and called attention to the excellent use which may be made of characters in the mandibles, palpi, antennæ, frontal fovea, clypeus, wings, abdomen, pygidium and legs. He would give generic rank to the sub-genera of Fox and Kohl, and would divide the family into four sub-families. He showed that all of the Fabrician species, of *Crabro*, 17 in number, have been placed in other genera, and he finds himself embarrassed to indicate the type of the genus *Crabro*.

L. O. HOWARD,  
Secretary.

BIOLOGICAL SOCIETY OF WASHINGTON—29<sup>TH</sup>  
MEETING, DECEMBER 30<sup>TH</sup>.

PROFESSOR A. D. HOPKINS exhibited some diagrams illustrating a system devised by him for showing in a graphic manner the evolutionary development of families, genera and species.

Mr. Charles L. Pollard discussed 'Floral Asymmetry in *Chamaecrista*,' explaining with the aid of diagrams the peculiar irregularity in the corolla and calyx whereby the banner petal, instead of occupying a normal uppermost position, has undergone a torsion of 90° to the left. This remarkable discovery was made originally by Professor E. L. Greene, who considered that it entitled the Chamaeristoid *Cassias* to rank as a distinct genus. Other generic characters were pointed out by Mr. Pollard.

Mr. Herbert J. Weber spoke of 'The Affinities of *Casuarina*,' discussing the external resemblance of *Casuarina* to *Equisetum* and the very close resemblance to *Ephedra* of the Gnetales. The theory of their probable derivation from this group was accepted.

The subject of Chalazogamy in *Casuarina* was discussed somewhat in detail, the speaker taking exception to Nawaschin's theory that Chalazogamy is a primitive type of fecundation from which porogamy has been developed. The principal reasons advanced for thinking Nawaschin in error were:

1. Porogamy is the general type of fecundation in the Angiosperms, and is of special interest, as regards the Monocotyledons, which doubtless had a separate origin from *Casuarina* and other Dicotyledons, but were, neverthe-

less, derived from the Gymnosperms, where uniformly a slightly different type of porogamy from that occurring in the Angiosperms exists. As in the Monocotyledons, porogamy developed from a Gynnospermous type of fecundation, the speaker thought it more reasonable to think that the same type of fecundation had also appeared first in the ancestors of the Dicotyledons.

2. From the universal presence of the micropyle in all Gymnospermous and Angiospermous plants.

3. From the universal location of the egg cell in all Angiosperms in close proximity to the micropyle, instead of the chalaza.

The speaker took the ground that Chalazogamy may probably be looked upon as a degenerate form of fecundation rather than a primitive type.

Mr. O. F. Cook presented a paper entitled 'Four Categories of Species,' in which it was claimed that the general problems of taxonomy are four in number, and that from the standpoint of the work of investigation they may be looked upon as practically distinct. The term species has been employed in treating all four lines, being used (1) for arbitrary section of lines of individual succession, the 'species' of phylogeny and paleontology. (2) The insular or segregated species, the original and still the leading use of the term. (3) The incipient species, more properly called the sub-species. (4) The artificially selected or hybridized 'species.' It was insisted that the fact of segregation is capable of establishment by sufficiently careful and extended observation; that it gives our most important clew to the present tendencies of evolution, and that the term 'species' should be restricted to naturally segregated groups of individuals.

F. A. LUCAS,  
Secretary.

THE NEW YORK SECTION OF THE AMERICAN  
CHEMICAL SOCIETY.

THE local Section held its regular meeting at the College of the City of New York on the 9th inst., Dr. William McMurtrie presiding, and ninety-five members and visitors were present. An unusually long and interesting pro-

gram was announced, of which the following papers were read:

'Preliminary Note on proposed Patent Legislation in its Relation to American Chemists,' C. C. Parsons.

'Atomic Weights as a Cyclic Function,' Thomas Bayley, England.

'Recent Progress in Photo-Chemistry,' L. H. Friedburg.

'The Commercial Electrolysis of Salt in the United States,' H. Carmichael.

'Notes on the Electrolysis of Salt,' J. D. Pennock.

On motion the Chair was authorized to appoint a committee of three to consider what action should be taken on proposed patent legislation.

The Chairman reported that the Chemists' Club had been duly organized and the rooms leased, and it was expected that all necessary furnishing would be completed in time for the meeting of the general Society in the Holiday week.

The announcement was made that the membership of the Section has passed the 300 mark, which, in accordance with the provisions of the new constitution, allows the Section four representatives on the Council.

The Secretary was, therefore, directed by unanimous vote to cast a ballot electing the following gentlemen to represent the Society: William McMurtrie, A. A. Breneman, C. A. Doremus and A. H. Sabin; and in the event of any of these being elected Councillors-at-Large, Durand Woodman, J. B. F. Herreshoff, E. G. Love, E. E. Smith, Geo. C. Stone and C. B. Voorhees as alternates in the order named.

The Executive Committee decided to postpone the next regular meeting of the Section to Friday, January 13th, to avoid following the midwinter meeting too closely. The General Secretary reports a number of papers already promised for the midwinter meeting, and all arrangements progressing favorably.

DURAND WOODMAN,  
*Secretary.*

NEW YORK ACADEMY OF SCIENCES—SECTION OF  
PSYCHOLOGY AND ANTHROPOLOGY.

THE Section of Psychology and Anthropology

of the Academy is now in its third year. Six meetings have been arranged for the current season. The Section meets on the fourth Monday evening of the month at 12 West 31st Street.

At the first meeting, which was held October 24th, Professor Cattell presented a paper upon anthropological tests and instruments, outlining the advance which has been made in methods and apparatus in the psychological measurements of Columbia students.

Reports of summer field work in anthropology were made by Dr. M. H. Saville and Dr. Carl Lummholtz, speaking of work in Mexico, and by Dr. Farrand and Mr. Harlan I. Smith, whose work was on the Northwest coast, principally in Washington.

The program of the second meeting, November 28th, included a paper by E. G. Dexter, on 'The Influence of the Weather on the Mental Activities of Children,' and one by Geo. V. Dearborn, on 'Involuntary Reactions to Pleasant and Unpleasant Stimuli.' Anthropological papers were contributed by Stansbury Hagar, on 'The Water Burial,' and by A. Kroeber, on 'The Eskimos of Cumberland Sound.'

C. B. BLISS,  
*Secretary.*

HARVARD UNIVERSITY: STUDENTS' GEOLOGICAL  
CLUB, NOVEMBER 22, 1898.

MR. H. F. KENDALL offered an explanation for the formation of an over-hanging, rock cliff on the eastern flank of Mt. Passaconaway, N. H. Mr. H. T. Burr traced the evolution of explanations for the 'Origin of Eskers,' and concluded that this form of ice records is of sub-glacial origin.

*Geological Conference, November 29, 1898.*—Dr. R. A. Daly presented results obtained in connection with an attempt to express, mathematically and graphically, the optical characters of the vertical zone of amphiboles and pyroxenes. A formula was deduced, which showed the variation in the extinction-angle (read against the cleavage-trace) characteristic of a plane revolved<sup>1</sup> in the vertical zone from the position (010) to the position (100). This formula is a special case of Michel Lévy's general expression for the extinction in any zone.

By successive applications of the formula, curves were constructed for negative amphiboles on rectangular coordinates, in which the ordinate indicates the value of the extinction-angle on (010), and the abscissa the amount of rotation of the 'plan mobile,' out of the plane of symmetry toward the orthopinacoid. These curves were plotted for amphiboles in which the optical angle is 50°, 60°, 70°, 80°, and the extinction-angle on (010), in each case, 10°, 15° or 20°. To these were added the analogous curves for  $2V=90^\circ$ . The last were unlike the former in that they showed no maximum value of extinction between (010) and (100). When the optical angle is small, the maximum extinction may be found to be in a plane far removed from (010), contrary to the statement of Zirkel that the maximum must always lie in the plane of symmetry.

Secondly, a method for determining the extinction-angle of amphiboles and pyroxenes (010) was proposed. The object of this new method is to avoid cutting oriented sections, as this operation is manifestly impossible with many rock-forming varieties.

'Two Remarkable Explosions in the New York Oil District' were described by Mr. L. LaForge. On March 1, 1898, three hundred quarts of nitro-glycerine exploded in a magazine, about one mile east of Wellsville, N. Y. Structures in that village suffered much damage; chimney-tops fell and windows were broken inward. One week later, six hundred quarts of nitro-glycerine exploded in the new magazine on the same spot. In this case no serious damage to buildings in the village resulted, although the report and shock of the explosion extended much farther. When the former explosion took place the ground was frozen, but before the latter occurred it had thawed out. It is to this fact that the people of Wellsville attribute the difference between the results of the two explosions.

J. M. BOUTWELL,  
Recording Secretary.

#### THE ACADEMY OF SCIENCE OF ST. LOUIS.

At the meeting of the Academy of Science of St. Louis on the evening of December 5, 1898, Mr. H. von Schrenk presented by title a

paper 'On the Mode of Dissemination of *Usnea barbata*,' and Professor L. H. Pammel presented by title a paper on 'The Histology of the Caryopsis and Endosperm of some Grasses.'

Dr. Theo. Kodis presented the results of some experiments on overcooling animal and vegetable tissues, in which it was shown that, as water may, under favorable conditions, be cooled to some distance below zero, Centigrade, without freezing—the temperature immediately rising to the freezing point the moment that freezing begins, and remaining there until the water is entirely solidified, then beginning once more to drop—so, when animal and vegetable tissues are experimented on, they may be cooled to a temperature decidedly lower than the freezing point, under favorable conditions, before freezing begins, but that, when it begins, the temperature at once rises to the freezing point (which is always somewhat lower than that of pure water), remaining there until the process of freezing is complete, when it once more begins to fall. The speaker gave a short account of the current theories as to the mechanical constitution of protoplasm, and discussed the bearing on them of the phenomena when the solidification of overcooled tissues began.

WILLIAM TRELEASE,  
Recording Secretary.

#### NEW BOOKS.

- Aperçus de taxonomie générale.* J. P. DURAND. Paris, Felix Alcan. 1899. Pp. 265. 5 fr.
- Natalité et Démocratie.* ARSÈNE DUMONT. Paris, Schleicher Frères. 1898. Pp. 230.
- Catalogus Mammalium tam viventium quam fossilium.* E. L. TROUSSART. Berlin, R. Friedländer und Sohn. 1898. Fasciculus IV. and V. Pp. 665-1264. 26 Marks.
- Principles of Biology.* HERBERT SPENCER. New York, D. Appleton & Co. 1898. Revised and Enlarged Edition. Vol. I. Pp. x + 706. \$2.00.
- Degeneracy.* EUGENE S. TALBOT. London, Walter Scott, Ltd.; New York, Charles Scribner's Sons. 1898. Pp. xvi + 37. \$1.50
- Psychologie der Veränderungsauffassung.* L. WILLIAM STERN. Breslau, Preuss und Yünger. 1898. Pp. viii + 264.



# SCIENCE

EDITORIAL COMMITTEE: S. NEWCOMB, Mathematics; R. S. WOODWARD, Mechanics; E. C. PICKERING Astronomy; T. C. MENDENHALL, Physics; R. H. THURSTON, Engineering; IRA REMSEN, Chemistry; J. LE CONTE, Geology; W. M. DAVIS, Physiography; O. C. MARSH, Paleontology; W. K. BROOKS, C. HART MERRIAM, Zoology; S. H. SCUDDER, Entomology; C. E. BESSEY, N. L. BRITTON, Botany; HENRY F. OSBORN, General Biology; C. S. MINOT, Embryology, Histology; H. P. BOWDITCH, Physiology; J. S. BILLINGS, Hygiene; J. McKEEN CATTELL, Psychology; DANIEL G. BRINTON, J. W. POWELL, Anthropology.

FRIDAY, DECEMBER 30, 1898.

REFORM IN MEDICAL EDUCATION.\*

## CONTENTS:

<i>Reform in Medical Education:</i> PROFESSOR H. P. BOWDITCH.....	921
<i>On the Increasing Importance of Inorganic Chemistry:</i> PROFESSOR HARRY C. JONES.....	927
<i>The Tailless Batrachians of Europe:</i> DR. THEO. GILL.....	932
<i>Skeleton Leaves:</i> ALBERT F. WOODS.....	938
<i>Problems of Physiography concerning Salinity and Temperature of the Pacific Ocean:</i> A. LINDEN-KOHL.....	941
<i>The Storing of Pamphlets:</i> PROFESSOR CHARLES S. MINOT.....	944
<i>Notes on Inorganic Chemistry:</i> J. L. H.....	945
<i>Current Notes on Meteorology:—</i>	
<i>Upsala Cloud Observations; Recent Anemometer Studies; San Francisco Rainfall; Frequency of Rainy Days in the British Isles:</i> R. DEC. WARD.....	947
<i>Current Notes on Anthropology:—</i>	
<i>Man and the Monkey; The Native Tribes of Costa Rica; The Chronology of Archaeology; Ethnography of German East Africa:</i> PROFESSOR D. G. BRINTON.....	948
<i>Scientific Notes and News.....</i>	949
<i>University and Educational News.....</i>	952
<i>Discussion and Correspondence:—</i>	
<i>The Origin of Mammals:</i> PROFESSOR O. C. MARSH. <i>Zoological Bibliography:</i> DR. W. H. DALL. <i>Lehman and Hansen's on the Telepathic Problem:</i> PROFESSOR WILLIAM JAMES.....	953
<i>Scientific Literature:—</i>	
<i>Jordan's Footnotes to Evolution:</i> PROFESSOR A. S. PACKARD. <i>Geikie on Earth Sculpture:</i> PROFESSOR JOHN C. BRANNER. <i>Story's Photography:</i> E. L.....	956
<i>Scientific Journals.....</i>	959
<i>Societies and Academies:—</i>	
<i>The Philosophical Society of Washington:</i> E. D. PRESTON. <i>Boston Society of Natural History:</i> SAMUEL HENSHAW. <i>Section of Astronomy and Physics of the New York Academy of Sciences:</i> R. GORDON.....	959
<i>New Books.....</i>	960

THE choice of a physiologist as the presiding officer of the Society of American Naturalists might, perhaps, have justified me in selecting some of the problems connected with experimental physiology as the subject of my remarks this evening, but, as questions of this sort are wont to awaken but a languid interest except among those who are themselves engaged in physiological research, I have thought it better to allow my choice of a subject to be guided by the fact that we are nearly all of us actively engaged in teaching as well as in studying our sciences, and to address you this evening upon some topic connected with education.

My own experience of 27 years as a professor of physiology and of 10 years as Dean of the Harvard Medical Faculty naturally inclines me to discourse upon the subject of medical education and, since the great profession of medicine demands from its practitioners a certain familiarity with the fundamental truths of all the natural sciences, it can surely not be inappropriate to ask the representatives of those sciences to consider with me how far the progress of medicine and of the allied sciences has made it desirable to revise our methods of imparting medical instruction.

\*Address of the President, delivered before the American Society of Naturalists at the New York meeting, December, 1898.

MSS. intended for publication and books, etc., intended for review should be sent to the responsible editor, Professor J. McKeen Cattell, Garrison-on-Hudson, N. Y.

Let me say at the outset that in speaking of the profession of medicine I use the term not in its narrow sense, to designate the art of curing disease, but in its broader signification, to include a study of the whole environment of man as far as it affects the production and maintenance of a healthy mind in a healthy body.

In what I shall have to say on this subject I shall confine myself chiefly to the medical schools of this country, though it will be found, I think, that the conclusions to which I shall endeavor to lead you will have their application to medical schools through the world.

The most important event in the history of medical education in this country occurred some thirty years ago, when many of the principal schools abandoned the plan of giving a series of winter lectures, which were attended by all the students, irrespective of their proficiency, and established a graded system of instruction in which the studies of one year were preparatory to those of the next. Those whose experience in medical education is confined to the period since this change was made can scarcely appreciate the value and importance of the reform which raised the medical schools of the country from a condition in which they were aptly compared to joint-stock manufacturing companies, concerned only in taking in as large an amount as possible of raw material in the shape of medical students and in turning out a maximum of the finished product, *i. e.*, doctors of medicine, with a minimum cost to the producer. 'Cheap doctors and plenty of them' seems to have been the motto of the medical schools of that period. Since this reform the medical schools of the country have been conducted on sound educational principles and the best of them compare favorably with the medical schools of Europe.

During the last quarter of a century the

improvement in medical education in this country has consisted chiefly in increasing the requirements for admission, in the lengthening of the course and in the extension of the laboratory method of instruction. Important as these improvements have been, it may fairly be asked whether they have kept pace with the requirements imposed upon teachers by the remarkable advance in every department of medicine during the last thirty years.

During this period we have seen the germ theory of disease established upon a firm basis and extended so as to throw light upon a large number of morbid processes with which it was formerly supposed to have no connection. Antiseptic methods have revolutionized the surgeon's art. The study of the internal secretion of glands has led to the development of a system of glandular therapeutics. The use of the antitoxin treatment has robbed one, at least, of the most dreaded diseases of more than half of its terror, while the use of instruments of precision has increased the accuracy of our diagnosis in nearly all the ills to which flesh is heir.

At the beginning of this period it was possible to impart to an intelligent medical student in a three years' course of study a considerable fraction of the acquired medical knowledge of the time and to train him to safely use the comparatively simple methods of diagnosis and treatment then in vogue. At the present time, were we to seek to give to the same student a similar proportion of the accumulated knowledge now at the disposal of the profession and to teach him the use of the refined modern methods for the study and cure of disease, it may be reasonably estimated that a ten or even a fifteen years' course of study would be required. As it is obviously impossible to prolong the course of medical study to anything like this extent, the question arises: In what way shall newly ac-

quired knowledge in the science and practice of medicine be incorporated into the existing curriculum of the medical student?

Up to the present time this question does not seem to have been seriously considered. As new and important subjects have forced themselves upon the attention of the medical profession, our schools have sought to meet the new condition simply by adding to the existing curriculum a more or less lengthy course of instruction on the subject in question. Thus the importance of enabling physicians to recognize pathogenic microbes has led to the establishment of a department of bacteriology in our principal medical schools, while the great advance made in the treatment of special classes of disease has occasioned the appointment of numerous professors of specialties, such as gynecology, orthopedic surgery, pædiatrics, etc.

The medical curriculum has thus grown by what may be called, in biological language, a process of accretion, and there has been little or no attempt to make room for new instruction by the omission of less valuable courses or parts of courses, though in certain directions the advance of knowledge, by demonstrating the inaccuracy of previously accepted views, has led to a simplification of instruction. When it has been found absolutely impossible to add any further courses a remedy for the congestion of instruction has been found in the prolongation of the medical curriculum from three years to four.

It is, of course, evident that this process cannot be indefinitely continued. In fact, a slight study of the subject suffices to show that a limit has already been reached. Indeed, as long ago as 1870 Huxley was so thoroughly impressed with the crowded condition of the medical curriculum in England that he expressed "a very strong conviction that any one who adds to medical education one iota or one tittle beyond

what is absolutely necessary is guilty of a very grave offence,"\* and quite recently Professor M. Foster, in speaking of the enormously increased requirements in medical education, has expressed himself as follows: "Now it is obvious that, whatever may have been possible once, it is impossible nowadays to demand that all or each of these things should be learnt by the student of medicine. Though possibly the power of man to learn is increasing; though each science as it becomes more and more consolidated can be expounded and apprehended with greater ease; though the grasping of one science is in itself a help to the grasp of other sciences, yet beyond doubt that which has to be learnt is enlarging far more rapidly than is man's ability to learn."†

To extend the course of instruction in the medical schools of this country beyond the present four-year limit does not, under the prevailing conditions of education in America, seem desirable, and the curriculum of most of our schools is already so crowded that no considerable amount of instruction can possibly be added. In what way, then, can we give to our medical students an adequate amount of information on all the subjects embraced in the constantly widening domain of medical science and art? In other words, how shall instruction keep pace with knowledge?

In seeking an answer to this question it may be assumed that a medical school of the first rank should be an institution in which the most advanced instruction in all departments of medicine can be obtained, and on this assumption it is, of course, impossible to arrange a course of study that every student *must* follow in all its details, for in the time which may properly be de-

\* 'Medical Education.' Collected Essays, Vol. III., D. Appleton & Co., 1894.

† Address to the Students of Mason University College, Birmingham, October 3, 1898.



voted to a course of professional study it is quite impossible for even the most intelligent students to assimilate all the varied information which such a school may reasonably be expected to impart.

It seems, therefore, to be evident that in arranging a course of medical study a distinction must be made between those subjects which it is *essential* that *every* student should know, and those subjects which it is *desirable* that *certain* students should know, *i. e.*, between those things of which no man who calls himself a physician can afford to be ignorant, and those which are important for certain physicians but not for all. In other words, provision must be made both for required and for *elective* studies.

The introduction of the elective system into a professional school is not an altogether novel proposition. For several years a large part of the instruction in the fourth year of the Harvard Medical School has been given in elective courses in various specialties, such as ophthalmology, otology, etc. The extension of the elective system to the earlier years of the course would be attended by no difficulty as far as details of administration are concerned, and has, indeed, been advocated by President Eliot in a speech at the dinner of the Harvard Medical Alumni Association in 1895. But the question may, perhaps, be asked whether it will be possible under such a system to secure the proper training of young men for the duties of a profession in which experience of life contributes so largely to success, and in which, therefore, a student at the beginning of his career may be supposed to be peculiarly in need of the guidance of his teachers.

It is true that in the academic department of Harvard University the capacity of the average student to choose his course wisely and well has been demonstrated by the experience of many years, but it may be properly urged that the success of the system

in the academic department does not necessarily justify its extension to a professional school. The responsibility of the medical faculty in granting the degree of M.D. is very different from that of the academic faculty in giving the A.B. diploma, since an imperfectly qualified practitioner of medicine may endanger the lives of his patients, while an unworthy graduate of the academic department can, as a rule, injure no one but himself. Hence the medical faculty may justly be required to exercise greater caution in bestowing the degree of M.D. than is necessary in the case of the A.B. diploma. We must, therefore, enquire whether it is possible to obtain the advantages of a flexible curriculum consisting largely of elective courses without losing the security against superficial and imperfect work which the present compulsory system is supposed to afford.

Any one who is familiar with the existing methods of medical instruction is aware that in nearly every department many things are taught which are subsequently found to be of use to only a fraction of those receiving the instruction. Thus the surgical anatomy of hernia is taught to men who will subsequently devote themselves to dermatology; future obstetricians are required to master the details of physiological optics, and the microscopical anatomy of tumors forms a part of the instruction of men destined to a career as alienists. Now, no one can question the propriety of including instruction on all these subjects in the curriculum of a medical school, but it may be questioned whether *every* student should be forced to take instruction in them *all*. It may, perhaps, be urged that no choice of studies can be made without determining, to some extent, the direction in which the work of the future practitioner is to be specialized, and that such specialization cannot be properly and safely permitted until the student has completed his medical

studies. To this it may be answered that, whatever may be the dangers of too early specialization, the dangers of crowding the medical course with instruction of which many students do not feel the need and of thus encouraging perfunctory and superficial work are certainly no less serious. Moreover, it will, doubtless, be found perfectly possible to establish such a relation between the required and the elective courses that the requirements in each department will be in no way lowered, while a certain freedom of choice is permitted with regard to the direction in which the work is pursued. To illustrate this point, allow me to describe a possible arrangement of a course of study in the department of physiology with which I am, of course, more familiar than with any other.

In the Harvard Medical School instruction in physiology is now given in a course of about 100 lectures, besides recitations, conferences and practical laboratory work. Were the work to be rearranged in accordance with the above plan it would probably be found possible to condense into a course of about 50 or 60 lectures all the most important facts of physiology with which every educated physician must necessarily be familiar. Attendance upon these lectures, combined with a suitable course of text-book instruction, would suffice to guard against gross ignorance of physiological principles. In addition to this required work, short courses of eight or ten lectures should be provided, giving advanced instruction in such subjects as the physiology of the special senses, cerebral localization, nerve-muscle physiology, the internal secretion of glands, the physiology of the heart, circulation and respiration, the digestive secretions, the reproductive organs, etc. These courses should be elective in the sense that no student should be required to take them all. Each student

might, however, very properly be required to choose a certain number of courses, which, when once chosen, become, for him required courses leading to examinations. The number of special courses which each student should be thus required to elect should be sufficiently great to render the total amount of physiological instruction in no way inferior to that which is given under the present system.

It would, doubtless, be found desirable in practice not to confine the possibility of taking elective courses to the year in which the required instruction is given, for a student may frequently, in the latter part of his course, become interested in a subject like mental diseases, for instance, and will then be glad of an opportunity to take special instruction on the physiology of cerebral localization. The elective courses should, therefore, be so arranged that they may be taken in any part of the medical curriculum.

There is, in my opinion, no doubt that an arrangement of instruction similar to that here suggested for physiology could be advantageously adopted in the departments of anatomy, histology, bacteriology, medical chemistry, pathology, surgery, and in the courses of instruction in the various special diseases, such as dermatology, ophthalmology, etc. Whether the instruction in clinical medicine and clinical surgery can be thus modified is a question about which more doubt may be entertained and which I prefer to leave to persons of greater experience than myself in methods of clinical instruction.

Under the existing conditions of medical education the introduction of the elective system in some form or other seems to be an essential condition to any further important advance. If it be said that under this system the medical degree will cease to have the definite meaning now attached to it, and that it will be impossible to tell from his

diploma in what way a physician has been educated, it may be replied that, though the degrees of A.B., A.M., Ph.D. and S.D. are affected with exactly this same uncertainty of signification, their value seems in no way diminished thereby. As long as the M.D. degree stands for a definite amount of serious work on medical subjects directed on the lines above indicated we may be reasonably sure that those who hold it will be safe custodians of the health of the community in which they practice.

If it be urged that the elective system in medical education will lead to the production of a class of physicians who, owing to the early specialization of their work, will be inclined to overrate the importance of their specialty and to see in every disease an opportunity for the display of their special skill, it may be pointed out that this result is apt to be due not so much to early as to imperfect instruction in the work of a specialist, and that, since the elective system tends to encourage thoroughness in special instruction, the evil may be expected to diminish rather than to increase.

I have spoken of the extension of laboratory instruction as an important forward step in the improvement of educational methods in medicine during the last quarter of a century, and I desire to bring my remarks to a close with a few words on the relation between laboratory and didactic methods in medicine and on the employment of both methods in a system of instruction including both required and elective courses.

There is perhaps no field of human activity in which the pendulum of reform makes wider excursions than in that of education. Whenever any given method is found to give unsatisfactory results there is a strong tendency to abandon it altogether in favor of some entirely different method. Thus the obvious defects of the

oral system of examination employed in the Harvard Medical School thirty years ago led to its complete abandonment and to the adoption of the written examination book, though there is little doubt that a system combining the advantages of both the oral and the written methods could easily have been devised. In the same way the fact that many subjects have been, and indeed still are, taught in systematic didactic lectures which can be better taught by laboratory methods tends to obscure the equally important fact that there are many other subjects in the presentation of which the living personality of the lecturer is a very important factor and which, indeed, can be properly presented to students only by those who have had much experience in weighing scientific evidence. In this connection it is interesting to recall the wise words of Huxley, who expressed himself on this subject as follows: "What the student wants in a professor is a man who shall stand between him and the infinite diversity and variety of human knowledge, and who shall gather all that together and extract from it that which is capable of being assimilated by the mind."\*

To what extent the laboratory can replace the lecture room will, of course, depend upon the nature of the subject taught. In such a branch as Anatomy, where facts learned by observation form the greater part of the knowledge to be imparted, laboratory work can be substituted for didactic instruction to a greater extent than is possible in subjects like Physiology and Pathology, where inferences from observations and conflicting views must frequently be presented. In no department of medicine, however, will it probably be found possible to dispense entirely with a systematic course of lectures in which a trained instructor may give to his class the benefit of his accumulated experience.

\* *l. c.*



A consideration of the nature of the subject taught will also furnish a guide for the employment of laboratory and didactic methods in the required and elective courses above suggested. In general the required courses, being comparatively elementary and concerned chiefly with the presentation of well ascertained facts, may be made demonstrative in their character and may be conducted in accordance with laboratory methods, though a short course of didactic lectures, parallel with laboratory work, will in most cases be found to be essential. In the elective courses which provide advanced instruction in many directions the limits of our knowledge will be more nearly reached. It will, therefore, be necessary to present and weigh the evidence for and against the various conflicting views which are almost certain to be held with regard to subjects lying within what Foster has called the 'penumbra' of solid scientific acquisition. For this purpose the most suitable method of instruction seems to be a short course of carefully prepared didactic lectures which should, however, be varied by demonstrations whenever the nature of the subject will allow.

It is, however, unnecessary to discuss these and other details at the present time. They will speedily arrange themselves as soon as the necessity for a comprehensive reform in our methods of medical instruction is generally recognized, and it is in the hope of helping to secure this recognition that I have addressed these remarks to you this evening. In whatever way the remedy is to come it should not be long delayed, for the difficulty of giving adequate instruction to constantly increasing classes seeking information over a constantly widening field of knowledge is felt each year with greater and greater keenness.

H. W. BOWDITCH.

HARVARD MEDICAL SCHOOL.

ON THE INCREASING IMPORTANCE OF INORGANIC CHEMISTRY.\*

WHENEVER a paper by Vau't Hoff appears, it is read by chemists and especially by physical chemists, with unusual interest. This is due to the fact that the comparatively few papers which he has published have had such a marked influence on scientific thought, and on the development of those branches of knowledge to which he has devoted his energies.

The present lecture is probably the result of his observation, since he has been in Berlin, that by far the larger number of German chemists are devoting themselves to organic chemistry. At the same time that he recognizes the importance of this field of investigation, he utilizes this opportunity to call attention to the difference between the two branches of chemistry, organic and inorganic, and to point out some of the advances which have been made, especially in the latter. The main points of his lecture will be given partly in his own language, and partly as a free account of what was said.

The distinction between organic and inorganic compounds dates back some two hundred years. Those occurring in organic nature, in living things, were called organic, while those existing in the mineral kingdom were called inorganic. This division had, at the outset, a certain scientific justification, since inorganic chemistry had to deal with the comparatively simple problem of explaining the chemical transformations in dead matter, while organic chemistry dealt with the much more complex problem of the processes in living organisms.

While the original definitions of the two branches have changed somewhat as new facts have been discovered, yet this essential

\*Lecture before the 70th meeting of the Society of German Scientists and Physicians in Düsseldorf. —*Ztschr. f. Anorganische Chemie*, 18, 1.

difference still exists, that inorganic chemistry has to do with the relatively simpler, organic with the more complex problems. If we arrange the exact sciences in the order of increasing complication of the problems dealt with, we shall have inorganic chemistry more closely allied to physics, and organic chemistry to biology. The order would then be: Physics, inorganic chemistry, organic chemistry, biology.

Organic chemistry has now come to be the chemistry of the element carbon, while inorganic chemistry is that of the remaining 70 elements and their compounds. But we know that this distinction is not a sharp one, since sodium and calcium carbonates are treated in all works on inorganic chemistry. The two chief divisions of chemistry are, then, at present, best characterized by aim and method.

The more difficult problem in inorganic chemistry is the decomposition of substances into simpler compounds, and finally into the elements, so that the greatest triumph in inorganic chemistry is the discovery of new elements (Argon and Helium by Ramsay and Rayleigh). It finds the most complete expression of its results in the natural systems of Newlands, Mendeléeff and Lothar Meyer. The inorganic compounds are relatively simple, generally easy to obtain, and have a definite qualitative and quantitative composition.

The reverse is true in organic chemistry. Decomposition is easily effected, as by oxidation. The aim here is to synthesize compounds, and this is rendered difficult by the possibility of isomerism; substances being formed of the same composition, but of different constitution and properties. Organic chemistry triumphs in the artificial building-up of substances (the preparation of the different sugars by Fischer), and finds the most complete expression of its results in the structure theory and in stereochemistry.

The entirely different aims of the two branches of chemistry necessitate a corresponding difference of methods. As is well known, inorganic and organic chemistry are now studied independently. At the beginning of this century a great impulse was given to the study of chemistry by the discovery of the fundamental principle: "*The Mass of Matter does not change even in the most deep-seated transformations.*" At first the harvest was reaped chiefly in inorganic chemistry. The very important facts, discovered purely empirically—the impossibility of transforming one element into another, the weight and volume relations in chemical transformations—receive their hypothetical expression in the atomic and molecular conceptions and the molecular formula is the picture of the knowledge thus obtained.

Then came the harvest in organic chemistry. The methods of quantitative analysis were gradually adapted to the more complex relations in this field, and the constitution or configuration formula appeared, as a simple, clear picture of the relations. It indicated not only the kind and number of atoms in the molecule, but also their inner connections and their relative position.

Yet, organic chemistry has done comparatively little towards explaining the phenomena of life. The results of organic chemistry, expressed in the constitution formulas, are of relatively little significance for assimilation, etc. Also the knowledge of the constitution of albumin would thus be scarcely extended. "It appears to me as if this incapacity is conditioned also by the nature of the configuration formula. It represents the molecule as a solid unit, and corresponds, therefore, at best, to the relations which obtain at absolute zero, *i. e.*, at  $-273^{\circ}$ , and long before this all life processes are extinguished. The inner molecular state is explained for conditions under which life ceases."

Let us now look more closely at the condition of things at the present time. The discovery of thiophene by Victor Meyer, and Fischer's work on the sugars, are referred to. Notwithstanding the relatively small number of workers in inorganic chemistry in recent years, very brilliant results have been obtained. Those mentioned are: The discovery of the volatile compounds of iron and nickel with carbon monoxide, by Mond; of triazoic acid by Curtius; of six new elements by Ramsay; the artificial preparation of the diamond by Moissan; the carbides, selenides and borides, prepared by the same investigator.

Let stress be laid upon it that this experimental result is, in part, dependent upon the use of electricity, which is applicable chiefly to inorganic compounds. Let us examine more closely the details of this application; what electricity has already done, on the one hand as a source of higher temperatures, on the other as a means of effecting separations.

Electricity as a source of heat is of fundamental importance. The temperatures which can be reached by combustion processes are limited. By this means we cannot obtain temperatures very much above  $3,000^{\circ}$ . In the electric furnace temperatures as high as about  $4,000^{\circ}$  can be reached.

The electric furnace, in the hands of Moissan, has opened up a new way of preparing valuable and important substances. It is evident that this applies chiefly to inorganic chemistry. Higher temperatures do not form, but break down the molecular complexes which constitute the problems of organic chemistry. Our own existence, which depends chiefly on the interaction of such complex molecules, cannot be continued up to  $50^{\circ}$ . The compounds of the hydrocarbons which were obtained in the electric furnace, as carborundum and calcium carbide, have no

value for the synthetical processes of organic chemistry.

If we turn to electricity as a means of separation, it is self-evident that it can be only indirectly applied to organic chemistry, whose chief aim is synthesis. Most of the organic compounds do not belong to the electrolytes, which can be broken down by electrolysis. Most of the metals can, however, be separated by the current, in a form suitable for weighing, by using the proper intensity of current, and can be separated from one another by using a suitable electromotive force. The halogens have recently been separated in the same manner. A step is thus taken for inorganic analysis, which is comparable to the work of Liebig on the analysis of organic substances.

What has been accomplished by the use of electricity in separating the metals on a large scale, can be seen from the following data: In 1897 one-third of the entire copper produced (137,000,000 kilograms) was obtained electrolytically. The larger part of the gold and silver were obtained in the same way. Sodium is produced entirely by electrolysis (260,000 kilograms in 1897), and the increase in the aluminium produced, from 9,500 kilograms in 1888 to 321,000 kilograms in 1894, is to be referred to the same cause. This aluminium can now be used for the preparation of other metals which were difficult to obtain. At the last meeting of the Electrochemical Society in Leipzig we saw almost chemically pure chromium prepared by suitably igniting a mixture of aluminium and chromium oxide. In the same manner, manganese, titanium, tungsten, vanadium, cerium, etc., were formed. This opens up a field in the metal alloys, which will, perhaps, be of technical importance.

We thus see inorganic chemistry teeming with remarkable discoveries, enriched by a new method of preparing substances, and



simplified analytically. The ground is also unusually fruitful for applying and developing the fundamental generalizations which have been reached in chemistry in the last few years.

When, in 1843, Kopp declared that a new stage of development in chemistry would follow the period of quantitative investigation, first by union with another branch of science, he saw in advance what is now being effected in the union of chemistry and physics, which is being accomplished by the new physical chemistry. Let us call attention to the importance of applying the two fundamental principles of thermodynamics to chemistry, and how far consequences derived from these principles can be subjected to experiment, and what the result is.

The problems solved in this way, belong to the most important of our science, but receive a solution which has so little in common with our atomic and structural conceptions that they often do not appeal to chemists trained in the latter school. By this means problems will be solved, also biological problems, which lie out of the scope of the configuration method. By applying thermodynamics to chemistry it is chiefly inorganic chemistry which is advanced.

We must mention first the problem of affinity. Thermodynamics does not refer affinity to the reciprocal action of atoms, but measures affinity by the maximum work which the reaction can perform. Let us consider reactions which take place with increase in volume, say the union of copper and calcium acetates to form the double salt. If this reaction takes place in a closed vessel, the walls are broken. On the other hand, the reaction can be hindered by bringing a counter pressure to bear on the salts, say by a piston and cylinder; and Spring has actually shown that the double salt can be broken down by subjecting it to several thousand atmospheres of pressure. This counter pressure, which just prevents the re-

action, is very closely connected with affinity regarded as force, and affinity is determined as work by the mechanical work which is done by the reaction against the maximum pressure.

The reaction may complete its maximum work in other ways, as in an electric battery, and it can then be measured from the electromotive force of the battery.

We arrive, in this way, at a generalization of very great importance:

*A transformation will, then, only take place of itself in case it is in a position to do a positive amount of work. If the amount of work done is negative the transformation can only take place of itself in the opposite sense. If the work done is zero it can take place in neither sense.*

This work and the possibility of reaction depending upon it, can be calculated in any given case, provided the work is ascertained, once for all, which is done when each of the substances in question is formed from the elements. This work can be expressed, *e. g.*, in calories. This 'work of formation,' by simple addition and subtraction, leads to the 'work of transformation,' the sign of which conditions the possibility of the transformation. This program has been carried out, to a certain extent for the mercury compounds, by Nernst and Bugasky. It should be mentioned that from this principle it was foreseen that mercurous chloride must be decomposed by potassium hydroxide, although the transformation takes place with heat absorption.

We have obtained, also, a generalization for reactions which only partly complete themselves, on account of the introduction of the opposite reaction, which leads to a condition of so-called chemical equilibrium, as in the combination of iodine and hydrogen, and in etherification. It is essential that, in such cases, changes in concentration should be produced during the reaction, and on account of the reaction. These decrease the work of transformation, finally

bringing it to zero, whence the reaction velocity gradually decreases and finally, also, becomes zero. In the union of iodine and hydrogen the increasing concentration of the hydriodic acid formed, introduces a gradually increasing opposing force, which finally brings the reaction to rest.

There is thus obtained a further principle, applicable in many directions. The point at which a reaction comes to rest can be calculated from the work of transformation. This was strikingly confirmed very recently by Bredig and Knüpfner, on the basis of measurements of electromotive force; it was accurately determined when the double decomposition of thallic chloride and potassium sulphocyanate came to rest.

But also the change in work of transformation through changes in temperature, pressure and mass can be calculated from thermodynamics, and also the consequent shifting of the point of equilibrium. Quantitatively expressed, this shifting always takes place in the sense that cooling favors whatever is formed with evolution of heat, until finally, at absolute zero, all reactions are completely displaced in this sense. Then the course of the reaction would be conditioned by the 'heat of transformation,' which, at zero, would be equal to the work of transformation.

In studying equilibria from this standpoint, not only the *existence* of every substance, but also the *conditions of existence*, are determined. And it may be added, not only the conditions of existence of individual substances are determined, but also all the compounds which it is possible to obtain from given materials, say water and salt. The reinvestigation of magnesium chloride from this standpoint gave not less than six different hydrates.

This method of investigation closely resembles the complete survey of a region where formerly only individual cities and villages were recorded. In the not very

distant future inorganic chemistry may do for geology what it has already done for mineralogy in the preparation of individual minerals.

The views here expressed will be of chief service in inorganic fields, since two obstacles are in the way of applying them to organic chemistry: First, the great possibility of compound formation. A single pair of substances, as carbon and hydrogen, gives rise to an unlimited series of compounds. Second, the very sluggish manner in which organic transformations take place, causes reactions which are possible, to proceed very slowly, or not to take place at all. Thermodynamics stands here, in its application, as before a very complex engine which is rusted until it is useless.

But the application of thermodynamics to chemistry has been made in another direction, and here the physical chemistry of to-day has found its most fruitful field. The possibility of determining the molecular weight of dissolved substances is given by the so-called osmotic methods. A very great need of inorganic chemistry would thus be met. The molecular weights of organic compounds, which are often volatile, were generally known by determinations of vapor-density. The inorganic compounds investigated in this respect were, on the other hand, exceptions. The work of a few years has sufficed to fill up these omissions.

We arrive, then, at our last point, a consequence of these osmotic methods, that electrolytes—salts, acids and bases—are broken down in aqueous solution in a peculiar manner. The only explanation which meets the case is that of Arrhenius, according to which a dilute solution of, say hydrochloric acid, would contain instead of molecules of acid, negatively and positively charged atoms of chlorine and hydrogen.

It is still impossible to pass final judg-

ment on this fundamental change of our conceptions, yet it is a fact that the most widely different properties of solutions agree qualitatively with the new conceptions. Quantitatively, the result calculated agrees very nearly with that found, but, thus far, the agreement is not always perfectly satisfactory. It is of chief importance for our purpose that a new impulse was thus given to the study of solutions of salts, acids and bases, *i. e.*, chiefly to inorganic compounds.

A final remark in closing: While it has been repeatedly emphasized, in the foregoing that it is chiefly inorganic chemistry that has been advanced by the new theoretical considerations, yet it is not meant that organic chemistry has thus lost in interest. On the contrary, the science of chemical equilibrium can be applied also here, and has already been thus applied.

The action of ferments is then taken up, and the work of Tammanu and others cited to show that such act, at least in some cases, to only a limited extent, a condition of equilibrium being reached before the decomposition is complete. Thus, amygdalin is only partly broken down by emulsin, and the breaking-down goes farther if the decomposition products are removed. If, on the contrary, he had added the decomposition-products he would, perhaps, have effected the synthesis of amygdalin. In case the ferment is not changed by its action, on theoretical grounds a condition of equilibrium must be introduced, and not a total transformation, and, therefore, the opposite reaction should be realized. It is a fair question to ask whether (from the science of equilibrium) sugar cannot be formed from carbon dioxide and alcohol, under the influence of zymase, when the pressure of the carbon dioxide exceeds a certain limit; and also whether trypsin is not in the position, under conditions given by the science of equilibrium, to form albu-

min from the decomposition products which it itself yields?

"If I have gone too far in these last expressions they may remain as proof that I always have a warm heart for organic chemistry." Van't Hoff concluded with the wish that Germany, which is in danger of being surpassed in inorganic chemistry by other nations; which has recently lost from this field such men as Victor Meyer, Lothar Meyer, Gerhard Krüss and Clemens Zimmermann, will soon again occupy a leading position, through the choice of young men of our science to enter this field.

HARRY C. JONES.

CHEMICAL LABORATORY,  
JOHNS HOPKINS UNIVERSITY,  
November, 1898.

*THE TAILLESS BATRACHIANS OF EUROPE.\**

THE anurous salient amphibians, or tailless batrachians, have been long favorite subjects of study in Europe, and much has been written upon their habits. Only a few years ago (in 1890) Dr. J. de Bedriaga published an elaborate monograph of the Amphibians of Europe (*Die Lurchfauna Europas*) giving very full descriptions of the species and their manner and customs. Now we have completed a still more elaborate work on a single order of Amphibians—the Salientia—including the frogs and toads and their relations. This work, entitled 'The Tailless Batrachians of Europe,' is by Mr. G. A. Boulenger, and has been 'issued to the subscribers to the Ray Society,' in two bound volumes or parts for the years 1896 and 1897; the pagination is continuous from the first into the second volume (pp. 211–376). Doubtless many of the 'subscribers' will rejoice in the diversification of the subjects monographed, for nearly a

\*The Tailless Batrachians of Europe. By G. A. Boulenger, F.R.S. London: printed for the Ray Society. 1897-1898. 2 parts, 8vo., t. p., iii, 376 pp., 24 pl., 7 maps.



generation has passed since any volume on vertebrates was published, the last having been 'a monograph on the structure and development of the shoulder girdle,' by W. K. Parker, issued for 1867. All the volumes published since 1880 have been devoted to insects in the Linnæan sense.

Mr. Boulenger has been 'for twenty-five years a close student and collector of these animals, which have always exercised an extraordinary fascination' on his mind and he has utilized 'the enormous material which had gradually accumulated in the literature, [his] own notes, and the unrivalled collection in the British Museum.' The outcome is worthy of the distinguished author, and we have a monograph which may serve as a model for other lands, and not least for the United States.

The first third of the work (p. 1-121) is an 'introduction' to Amphibiology, treating of the classification, external characters, integument, dermal secretion, skeleton, viscera, habits, voice, pairing and oviposition, spermatozoa, eggs, development and metamorphosis, tadpoles, hybrids, and geographical distribution. This introduction is illustrated by forty-seven cuts and three plates representing anatomical and physiological data. A most useful feature is the exhibition in dichotomous form of the 'external characters' (17), the 'osteological characters' (44), 'the chief differences in male uro-genital apparatus' (55), the amplexation or mode of embrace of the male (69), the nuptial asperities (70), 'the principal differences between the eggs' (79), and the characteristics of the tadpoles (105).

The characters thus clearly analyzed and exhibited among the Anurans may be considered to have been coordinated, and the resultant is a classification which expresses quite nearly an equation for the collective characters and is, therefore, a 'natural classification.' So uniform are the external

characters that not only are they no criteria of the mutual affinities of the various forms, but they are actually often misleading. The early naturalists distinguished among the phaneroglossate forms those with the upper jaw toothed or toothless and those with toes having terminal disks contrasted with

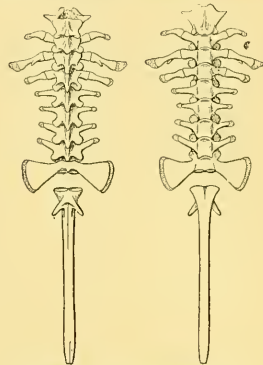

*Discoglossus pictus*, showing ribs.

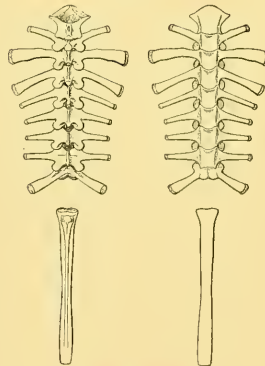

*Rana esculenta*.

those without disks. Other characters were found in the presence or absence of a 'tympanum' or 'ear' and of 'parotoid glands' as well as other less-used variations. It became evident, however, that none of the

arrangements based on such characters was an expression of deep-seated affinities. It was not till 1865 that a key to the definitive arrangement of the group was discovered by Cope in the osteological characters and especially modifications of the sternal apparatus. Cope's arrangement has been called by Mr. Boulenger an 'epoch-making classification' and, in the form to which it has been brought by the later labors of Cope and Boulenger, will doubtless be near that which will gain ultimate general acceptance. Nevertheless, it may be thought too much value has been attached to the arciferous type of sternum. An arrangement of the phanoglossate forms into three superfamilies, of which the arciferous family of *Discoglossidae* is the most generalized, may be more acceptable to some; this has been named DISCOGLOSSOIDEA. The other Arcifera are the BUFONOIDEA, and the FIRMISTERNIA are equivalent to another superfamily of nearly equal systematic importance—the RANOIDEA.

The Discoglossoidae differ from both the others in the possession of ribs in the adult, and by the median position of the spiraculum or outlet from the branchial chamber in the tadpole. Less important peculiarities are the arrangement of the male urogenital apparatus (so that 'the spermatozoa are conveyed through the vasa efferentia direct to the seminal duct; the latter produced forward beyond the kidney') and the disposition of the labial teeth series 'in two or three rows.' The single family—*Discoglossidae*—contains three European genera and five species; the genera were widely separated by the old systematists, and it was to Cope that the earliest appreciation of their relationship was due.

The Bufonoidea, or typical Arcifera, are represented in Europe by three families—*Pelobatidae*, *Bufonidae* and *Hylidae*. The *Pelobatidae* of Boulenger were distributed by Cope among two families, one of the Euro-

pean genera (*Pelodytes*) having been designated as the type of Pelodytidae, and the other (*Pelobates*) associated with the American *Scaphiopus* in the family Scaphiopidae. There can scarcely be any question that Boulenger is correct in reducing the two Copian families to one. The only characters

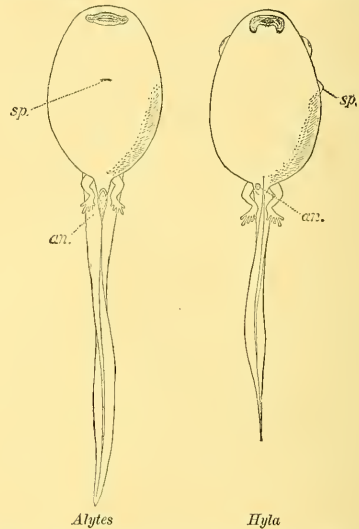

used to differentiate them were the 'sacrum united with the coccyx by condyle' in the *Pelodytidae*, and the 'urostyle without condyloid articulation, its axial portion restricting that of the sacrum and connate with it,' in the *Scaphiopidae*.\*

The inconstancy of this character in some groups has been shown by Boulenger. "Dugès, basing his observations [on the *Pelobates cultripes*], has denied the fusion of the sacral vertebra with the coccyx described by Mertens in *Pelobates fuscus*, with which *P. cultripes* was then confounded; he observes, however, that the articulation, by means of one condyle, is an almost immovable one.

\* Cope *Batr. N. Am.*, 296.

In a specimen from Bordeaux, from which [Boulenger] prepared the first skeleton, [he] found matters as stated by Dugès, whilst in two other skeletons, from Bordeaux and Avignon, the two bones are as completely fused as in *P. fuscus*." Mr. Boulenger well adds: "As the ankylosis of the sacrum and coccyx has been given as a generic character of *Pelobates*, it is important to note the inconstancy of the character in this species at least." Still less is the character of family value. Further, an examination of the skeletons of *Pelodytes*, *Pelobates* and *Scaphiopus* should convince a competent observer that the difference between *Pelobates* and *Pelodytes* are much less than those between *Pelobates* and *Scaphiopus*. *Scaphiopus* differs from *Pelobates* in the reduced dilatation of the diapophyses of the sacral vertebra, the strength and direction of other diapophyses, the cartilaginous 'xiphisternum,' the absence of a bony style, and the development of a 'cavum tympani and tympanum.' In all the contrasted characters *Pelobates* agrees with *Pelodytes*, and, if the family is to be divided, the two European genera should be combined and contrasted with the American. The eminent herpetologist who associated *Pelobates* with *Scaphiopus* was too much impressed at first with the special osteological character used, and neglected to make a detailed comparison which would have convinced him of its inferior value.

The Ranoidea are represented in Europe by only a single genus—*Rana*—although 8 of the 20 anurans belong to it.

Mr. Boulenger has paid much attention to the geographical distribution of the European species and has devoted a number of maps (6) to the exhibition of the range of the representatives of a family, genus, or of nearly related species or varieties. We may extend the view by a comparison of the European fauna based on Boulenger's figures with the North American, accept-

ing, therefore, the numbers given by Cope in 'The Batrachia of North America.'

	Europe.	N. Amer.
DISCOGLOSSIDÆ		
Discoglossus .....	1	
Bombinator .....	2	
Alytes .....	2	
PELOBATIDÆ		
Pelodytes .....	1	
Pelobates .....	2	
Scaphiopus .....		2
Spea .....		2
UPEROLIIDÆ (CYSTIGNATHIDÆ OR LEPTODACTYLIDÆ)		
Lithodytes .....		2
Syrhopus .....		4
BUFONIDÆ		
Bufo .....	3	10
HYLIDÆ		
Hyla .....	1	9
Pseudacris (Chorophilus) .....		6
Acris .....		1
Smilisca .....		1
ENGYSTOMIDÆ		
Engystoma .....		1
Hypopachus .....		1
RANIDÆ		
Rana .....	8	13

It will be seen from these columns that the North American fauna is much richer than the European. The chief differences, otherwise, are the absence of Discoglossids in America and the great development in North America of the Hylids—17 American against a single European species. There is no great disparity between the other families, although for each the American species are more numerous than the European. The families indicated as represented in North America and not in Europe do not really belong to the Anglogæan fauna, the species in question barely extending within the limits of the United States, the only notable exception being the *Engystoma carolinense*, which extends as far north as South Carolina and Missouri.

The chief interest to most lovers of nature will be in the accounts of the habits of



the species, and these, as a whole, are detailed more fully and with more discrimination than in any other work. Especially noteworthy are the descriptions of the courtship and oviposition of the species. The 'amplexation,' or mode of approach of the males on the females, is characteristic, and in main features is common to the members of a genus, so far at least as the European species are concerned. So generally in conformity with structural features has it been regarded that the principal modifications have been used to differentiate and diagnose certain groups. Attention was first called to the subject by A. Thomas in 1854, and two groups were named by Bruch, in 1863, *Plagioglena* and *Orthoglena*, and by A. de L'Isle, in 1877, *Alamplexes* and *Inguinamplexes*. But the want of correlation between such characters and structural ones is now evident. Mr. Boulenger (p. 2) well remarks: "How exaggerated the importance attached to this correlation, which, besides, holds good only for the European forms, is now apparent to all." Nevertheless, within

For example, Mr. Héron-Royer (Bull. Soc. Zool. France, 1890, 205) recognized 7 categories of amplexation—pectoral, axillary, supra-axillary, inguinal, axillo-in-

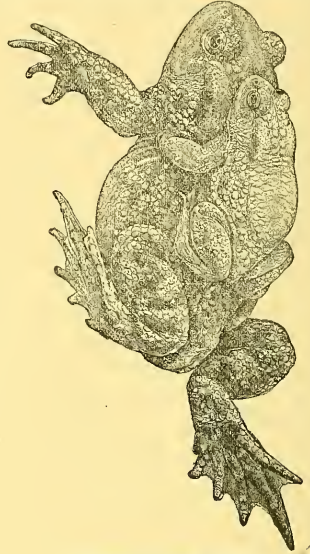

Amplexation of '*Bufo vulgaris*'



Amplexation of '*Pelodytes punctatus*'

guinal, lumbo-pubic, and lumbar. Now, Mr. Héron-Royer recognized five European species of *Hyla*, which are considered by Mr. Boulenger to be varieties or variations of the single species *Hyla arborea*, and yet two of the nominal species are referred to one category (axillary) and three to another (supra-axillary). One of the European toads (*Bufo viridis*) has a pectoral amplexation, two (*B. vulgaris* and *B. calamita*) an axillary, and the common American species (*B. musicus* or *lentiginosus*), a supra-axillary habit. In fact, such differences may be simple expressions of the relative size of the male and female and must vary as do the sexes. But there is a sharp contrast between amplexation round the waist and

certain limits, the species of a genus agree in their mode of amplexation; only a too strict taxonomy cannot be applied.

that behind or above the arms, and these two categories are the chief ones recognized by Mr. Boulenger. The former mode is exemplified by all the species of Discoglossids and Pelobatids; the latter by the Bufonids, Hylids and Ranids. Four kinds or degrees of amplexation are represented by admirable illustrations in Mr. Boulenger's work and are here reproduced. Among the Pelobatids the hands join on the pubic

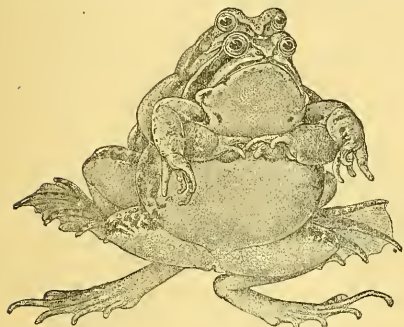

Amplexation of '*Rana arvalis*.'

region in *Pelobates*, while the forearms meet on the pubic region in *Pelodytes*. It will be in order now for some observer to tell us how *Scaphiopus* practices amplexation; the various accounts hitherto published fail to give the requisite information.

Every sojourner in the country must have noticed masses of transparent jelly-like spheres in the water, but none in the United States could refer such masses with certainty to the parent species. In Europe, however, such an identification can be made in almost every case, and Mr. Boulenger gives a synopsis for that purpose, and adds illustrations of the oviposition of seven species representing all of the five European families. Some of these illustrations are here copied.

The tadpoles of the European anurans have also been described and figured, and

each species may be readily identified by means of an excellent analytical key (105-109). The tadpoles of *Rana*, for example,

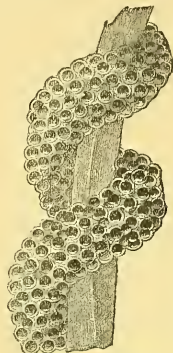

Eggs of *Pelodytes*.

are differentiated *inter se* by the relative width of the interocular space, the series of labial teeth, and the form of the tail. Mr. Boulenger deduces the generalization that "the structural differences which separate the genera and species in their tadpole condition reflect, on the whole, pretty accu-

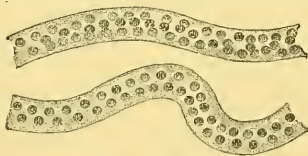

Eggs of *Bufo*.

ately the system based upon the perfect animals, although here and there the modifications are of unequal importance. We must bear in mind, however, that such a correspondence, if existing in the European Batrachians, is not universal. It is aptly added: "Larval forms such as the tadpoles are outside the cycle of recapitulation, the ontogeny being broken by the intercalation of the larval phasis."

Enough has been said to give some idea of the wealth of information given. As no other has had such opportunities of investigation as Mr. Boulenger, so no one has

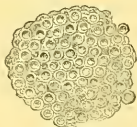

Eggs of *Hyla*.

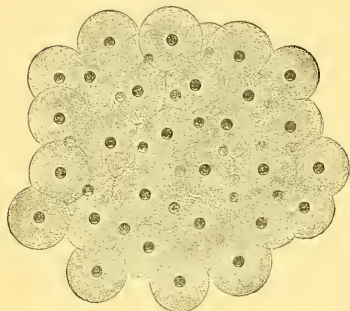

Eggs of '*Rana temporaria*.'

had greater capacity to use his material. Undoubtedly his monograph will long continue to be the standard of nomenclature. Nevertheless, there will be dissenters from some of the taxonomic ideas and some of the names adopted. For example, some may be disposed to differentiate the *Pelobates cultripes* from the genotype and call it *Cultripes provincialis* (with Cope) or *Cultripes cultripes*. Less likely will be the resurrection of *Ammoryetes* or *Epidalea*. Others too may assign higher value to forms designated as varieties of *Bombinator pachypus*, *Alytes obstetricans*, *Hyla arborea*, *Rana esculenta* and *Rana temporaria*.

Again, there may be differences of opinion as to various specific names. *Bombinator igneus* may be replaced by *B. bombinus* or possibly (but not probably) by *B. variegatus*. (The *Rana variegata* of Linnæus was

supposed to be a foreigner 'at large'—'*habitat in exteris regionibus*.'<sup>1</sup>) For the *Bombinator pachypus* may be revised the name *B. salsus*. The toad may be called *Bufo bufo* or *B. rubeta*. The *Rana arvalis* may be deemed to be entitled to the Linnæan name *R. temporaria* on the ground that it was the species to which the name was limited in the Fauna Suecica. Then the *R. temporaria* of the Tailless Batrachians may be called *R. muta*, as by Camerano and Bedriaga. Finally, for the *R. agilis* the name *R. dalmatina* may be preferred. In reference to the last, Mr. Boulenger has noted, "the strict law of priority would require the adoption of this name \* \* \*". However, this is one of those cases in which, it appears to me, conservatism is desirable." Mr. Boulenger adds: "Similar considerations have guided me in the naming of the two species of *Bombinator*, and I hope, in the interest of the stability of nomenclature, they will commend themselves to future workers."

But whether we agree with Mr. Boulenger or not in his views as to nomenclature, he certainly has given us a work which well deserves to be recognized as a standard and is alike meritorious for text as well as for illustrations. We may be allowed to hope that a companion volume on the remaining Amphibians of Europe will be published in time. From him who has given so freely, much will be expected.

THEO. GILL.

#### SKELETON LEAVES.

It has for a long time been known that the best method of skeletonizing leaves is to put them in a still pool containing moss, algæ or other living aquatic plants. In a few months, as a rule, all the softer portions of the leaf will disappear, leaving the vascular system perfectly clean from mesophyll and epidermis. The removal of the soft parts will take place more quickly if the leaves are killed before they are put in



the spring or pool. It has been supposed that the disappearance of the softer parts of the leaf was due to decay brought on by bacteria and fungi, and this may in some cases be true.

A few months ago some moss from a pool near the Great Falls of the Potomac was brought into the laboratory of the Division of Vegetable Physiology and Pathology and put into an aquarium. A few leaves of Norway maple affected with a spot disease were also put in to keep them fresh for a few days. It was soon noticed that the mesophyll and epidermis of the brown spots

ress through the water or aid them in crawling. The mandibles and mandibular teeth are stout and well adapted for gnawing. (See Figs. A-D.) An examination of the alimentary canal of several of the organisms revealed the presence of numerous leaf cells, palisade and mesophyll, in the process of digestion. Little doubt could, therefore, remain as to the fact that the *Cypridopsis* were the active skeletonizers.

Another aquarium, however, was started, and decay-producing fungi and bacteria were introduced to see if they would alone produce skeletonizing.

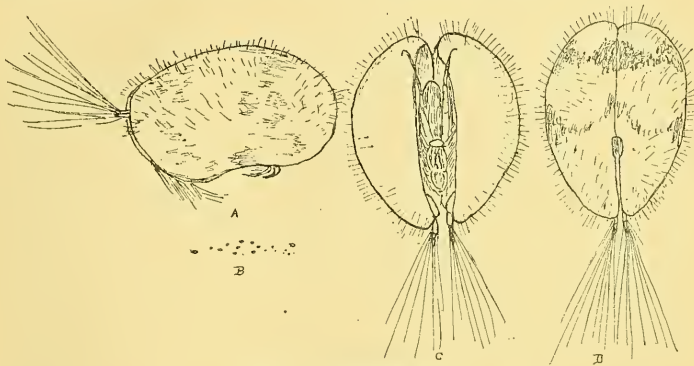

FIG. 1. *CYPRIDOPSIS* sp.

A. Side view  $\times 50$  diam. B. Natural size. C. Ventral view  $\times 50$  diam. D. Dorsal view  $\times 50$  diam.

was disappearing, leaving nothing but the vascular bundles. A closer examination revealed numerous minute bivalve crustaceans belonging to the family Cyprididae and as nearly as could be determined to the genus *Cypridopsis*, probably *C. vidua* (O. F. M.). The shells varied from  $1/2$  to 1 mm. long and half as broad and high. They are tumid, yellowish green and covered with short hairs. In swimming the plumose antennae and bristly feet protrude from the shell and by their rapid movement cause the organisms to make a jerky rolling pro-

gress. Two sets of leaves of Norway maple, Peach, Rose, Elm, Linden and a number of other plants were selected. One set was put in the aquarium containing the *Cypridopsis* and the other put in the aquarium with fungi and bacteria. The process of decay went on very rapidly in the latter aquarium, but there was no sign of skeletonizing a month and a half after the experiment was started. In the aquarium with *Cypridopsis*, however, the work was begun almost immediately. The dead spots in the leaves were skeletonized in 24 hours, and

in six days large areas were cleaned. In four weeks the work was complete.

The little crustaceans will not attack any portion of the vascular system of the leaves mentioned until the mesophyll and palisade cells are all removed and other leaves with mesophyll are lacking. If they are starved,

is hardly a pool or pond in which some of them are not found. It is quite likely that the food habits of many of them, at least of the closely related genera, are like the one here described.

*Cypridopsis* appears to thrive best in water kept fresh by the presence of algæ or

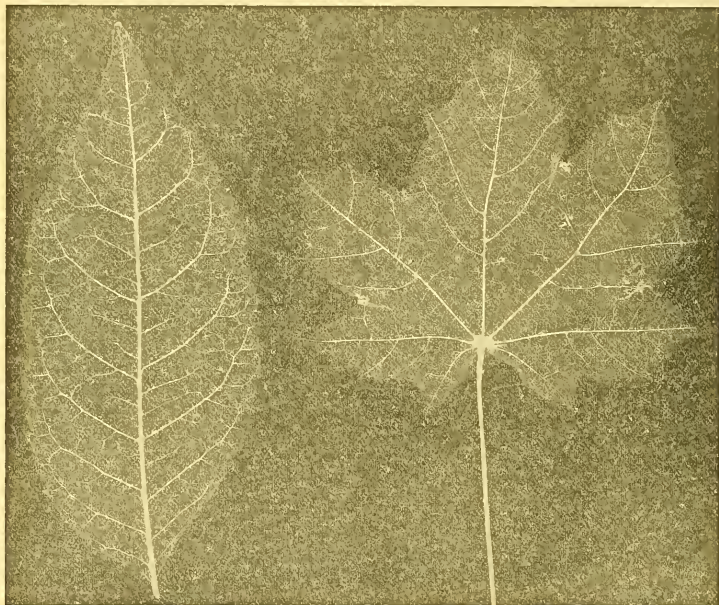

FIG. 2.

however, they begin on the finer bundles and soon destroy the specimen. It is best, therefore, when all the soft cells have been cleaned off from the bundles to remove the skeleton from the aquarium and press lightly between driers. The figure shows a maple and an ash leaf skeletonized in the experiment described.

*Cypridopsis* and related genera are widely distributed in fresh and salt water. There

other aquatic plants and not inhabited by fish or other animals which prey upon them. They are said, however, to live in dry mud, in a more or less dormant state for long periods.

ALBERT F. WOODS,  
*Assistant Chief.*

DIVISION OF VEGETABLE PHYSIOLOGY  
AND PATHOLOGY, U. S. DEPARTMENT OF AGRICULTURE.

PROBLEMS OF PHYSIOGRAPHY CONCERNING  
SALINITY AND TEMPERATURE OF  
THE PACIFIC OCEAN.\*

BERING SEA.

DIAGRAM No. 1 shows the mean temperatures and densities in the deeper parts of Bering Sea to the southward of the Pribilof Islands. It will be noticed that the density increases from 1.0241 at the surface to 1.0257 at the depth of 1,000 fathoms and according to a single observation to 1.0261 in 1998 fathoms at the bottom of the sea. We attribute the low density at the surface to a copious precipitation and to the discharge of several large rivers, notably the Yukon. This tendency towards a decrease of the density is counteracted by an undercurrent from the Northwest Pacific which carries a supply of salt. The relation of the Mediterranean Sea to the Atlantic Ocean furnishes an instructive illustration of the way in which salt and heat are conveyed from one sea to another; the same salt which is carried into the Mediterranean by a surface current is taken out again by a warm undercurrent which spreads out over an area extending from Gibraltar to beyond the middle of the Atlantic and, at the same time, sinks to depths below 1,500 fathoms. The Kuro Siwo, the great carrier of salt and heat in the North Pacific, does not, as a surface current, reach beyond 42° of Latitude, whence it passes northward beneath the surface, losing both heat and salt by its contact with colder and lighter water, and continues to sink as it advances until in the noted accumulation of salt in the deeper parts of Bering Sea we recognize the last traces of that warm and briny current. Lieut. Comm'r Moser in 1896 found the depth of the channel between Bering Island and Kamchatka to be 3,117 fathoms instead of less than 500, as has been here-

Diagrams illustrating  
Temperature and Density  
of the Pacific Ocean

S. 552

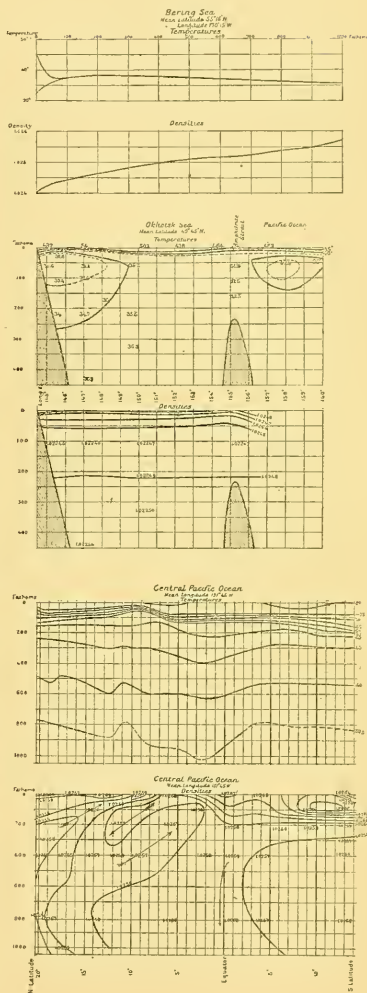

\* Abstract of a paper prepared for publication in the Annual Report of the U. S. Coast and Geodetic Survey for 1898 and *Petermann's Geogr. Mit.*



tofore assumed. We may admit that this great depth, as well as that of nearly 2,000 fathoms between Bering Island and the Aleutian Islands, to some extent facilitates the ingress of the waters of the Pacific, but in the matter of transfer of salt from one sea to another an ample supply of this substance is more essential than great depth of connecting channel. The Strait of Gibraltar, which, as we have seen elsewhere, regulates the density of not only the Mediterranean, but also of a large part of the Atlantic, has the moderate depth of 170 fathoms.

The temperature curve shows a minimum of  $37^{\circ}.5$  in 100 fathoms; this indicates that the heat which is transmitted from the surface does not descend below that limit and that whatever heat we find at greater depths has been conveyed by the same undercurrent which carried the salt. There is considerable difference in the bottom temperatures of the great depths; they vary from  $34^{\circ}$  to  $35^{\circ}$  and are perhaps slightly below those of the Pacific. We fail to notice any indications of a constant temperature below a certain depth, such as we find in the Caribbean Sea and Gulf of Mexico, where the thermometer registers  $39^{\circ}.5$  at all depths exceeding 700 fathoms. The observations on which the temperature curve is based were made about the middle of August, when the summer heat had nearly reached its maximum; the broken line indicates the probable conditions at the end of February, when the surface temperature is supposed to remain near the freezing point of fresh water.

#### THE OKHOTSK SEA.

IN the Diagram giving an east and west section through the Okhotsk Sea we notice in the western part the existence of a thick layer of very cold water at a short distance below the surface, covered by a stratum of very low density but of comparatively high temperature. When we recall that sea

water does not commence to congeal until its temperature is reduced to below  $29^{\circ}$  this cold layer furnishes an indication of the severity of a Siberian winter, when the whole of Okhotsk Sea is frozen over. The low density of the surface water is due to the fact that it is composed partly of melted ice, which does not contain much salt, and partly of river water, particularly that of the Amur, which, after rounding the northern point of Saghalin Island, floats southward along its eastern shore. It is rather surprising to find such steep gradients in the temperatures as  $54^{\circ}$  at the surface and  $31^{\circ}$  in 26 fathoms, and they can be accounted for only by assuming that there are no strong currents which keep the water agitated, and furthermore that, whatever the increased percentage of salt in consequence of evaporation may be, it is too small to sink the surface water to any considerable depth.

There are no temperature observations available for the water under the surface in the eastern part of Okhotsk Sea except bottom temperatures; we conjecture that during the winter months there is but little difference between the temperatures of the eastern and western part. In the height of summer, however, we may expect to find about  $35^{\circ}.2$  the lowest temperature at a depth of about 100 fathoms in the eastern part. At greater depths a slight increase of temperature is noticed,  $36^{\circ}.3$  is recorded at 328 and 437 fathoms, and there appears to be a nearly uniform temperature of  $36^{\circ}$  in the great depths of the basin, which, according to Moser's soundings in 1896, has the shape of a trough with a steep slope from the Kuril Islands, and depths exceeding 1,800 fathoms. The densities increase from 1.0222-1.0240 at the surface to 1.0246 at 55 fathoms and 1.0248 at 219 and 1.0254 at 437 fathoms. These relations of density and temperature are similar to those of Bering Sea, showing a continuous increase of density from the surface downward and

the existence of a minimum of temperature at the depth of about 100 fathoms, separating the much warmer surface waters from the slightly warmer deeper waters. Hence Okhotsk Sea, like Bering Sea, must receive a supply of salt and heat from a connecting sea by a current which starts at the surface and during its progress gradually sinks to the greatest depths. The Okhotsk Sea connects with the Japan Sea by La Pérouse Strait and with the Pacific by the Passages through the Kurils, and it may receive its supply of salt from either of these seas, but the observations by Makaroff in 1887 and Moser in 1896 point towards the Japan Sea as the source. Makaroff found in La Pérouse Strait three kinds of water, each of a distinctive physical character. In the southern part he found dense and warm water, with indications that it was from the Japan Sea on its northward way. In the northern part he found warm and light surface water similar to that we encounter farther north, off the shore of Saghalin Island; it is probably composed of melted ice and the waters of the Amur and other rivers which have come down from the northward along Saghalin Island. This surface water rests on water which has considerable density but a very low temperature; it is of the same character as that cold stratum which we found underlying the warm surface waters in a higher latitude, and we may, therefore, conclude that along the entire eastern shore of Saghalin Island the water below the depth of 25 fathoms receives but a small increase of temperature in consequence of the summer's warmth. Where it meets the water from the Japan Sea it rises to the surface in a streak which extends from Cape Crillon forty miles in a southeasterly direction, effectually shutting off the Japanese current from the western part of Okhotsk Sea. Moser's density observations show that this current advances northward in the eastern part of the Sea,

passing along the Kuril Islands, and that it is gradually overlapped by the lighter water to its left, thus verifying Makaroff's views, according to which the waters from the Japan Sea, after reaching the Okhotsk Sea, continue to sink until they occupy all the deeper parts of this basin. The depth of La Pérouse Strait is but 35 fathoms. The passages through the Kurils are probably much deeper. Makaroff gives 235 fathoms for the Amphitrite Strait, and from Moser's temperature observations, we infer that about 800 fathoms' depth may be carried from the Pacific into the Okhotsk Sea. From this we may conclude that, if the Okhotsk Sea does not receive a supply of salt and heat through an undercurrent from the Pacific, it is not on account of an insufficient depth of channel, but due to a greater difference between the physical condition of the waters of the Okhotsk Sea and those of the Japan Sea than exists between the former and those of the Pacific adjoining. The cold zone along the Kuril Islands was formerly thought to be due to the effect of cold currents which were supposed to come from the neighborhood of Kamchatka, but Makaroff correctly attributes the low temperature to a commingling of the cold water from lower strata with the surface water. There are instances where cold water rises to the surface in consequence of peculiar conditions of density and temperature, as in the case of the cold streak at the equator off the west coast of South America; but in the present case an inspection of the diagram will show that the rising is confined to the upper stratum of 25 fathoms' depth, and that it should be attributed to the bottom configuration, which offers formidable obstructions to the movements of a formidable tidal current sweeping through the passages four times a day.

#### THE CENTRAL PACIFIC OCEAN.

THE Diagram shows a section of the Pacific

Ocean in the tropics along the meridian of  $151^{\circ} 45'$  W., a short distance to the eastward of the Hawaiian Islands. The surface densities in this section, and generally in the South Pacific, are higher than in the North Pacific; this is due mainly to the fact that no large rivers, draining extensive continental areas, empty their waters into the South Pacific. As a rule the densities decrease from the surface to the depth of about 300 fathoms, where densities from 1.0254 to 1.0257 are found; thence there is a very gradual increase to the bottom, where 1.0259 is reached. This depth of 300 fathoms indicates the approximate limit to which salt and heat are carried through the process of surface evaporation. But there is another cause which brings the waters of the ocean into motion and tends to diffuse salt and heat into regions which are not affected directly by evaporation. If two differently constituted bodies of seawater meet under the conditions of equilibrium, the one composed of dense and warm, the other of light and cold water, an effort towards equalization of the proportions of salt and heat at the plane of contact will develop a tendency in the denser water to sink and in the lighter water to rise to a higher level. The waters of the South Pacific, being denser and warmer in the upper stratum than those of the north Pacific, exhibit this tendency to sink in the vicinity of the equator, where with a density of 1.0259 to 1.0260 at a depth of 200 fathoms they descend to more than 1,000 fathoms' depth. At the same time the light water of the north Pacific rises from the depth of 800 fathoms in latitude  $20^{\circ}$  N. with a density of 1.0254 in an oblique direction towards the equator, arriving in latitude  $3^{\circ}$  N. with a density of 1.0258 at 50 fathoms from the surface. The effects of the sinking of the dense and the rising of the cold water are shown in the diagram of temperatures by the high temperatures

between the equator and  $10^{\circ}$  N. latitude at all depths exceeding 150 fathoms and by the existence of a minimum of surface temperature at the equator itself. We note a second example of bodies of water changing their level in the upper left-hand part of the diagram, where dense and warm water from the region of the equatorial counter current undermines the north equatorial current and forces its light and cold water towards the surface. The diagram has the defect of showing motion in only two directions, vertical and meridional, while the third component, the most important one, that in an east-and-west direction is not represented and hitherto has not received our attention. The presence in the south Pacific of water at the depth of 100 fathoms with greater density than is found at the surface cannot be accounted for by mere sinking 'in loco,' but we have to assume that the surface water has drifted to its present position by a current from the eastward, while the lower water comes from a more southerly direction. Likewise, we find in latitude  $9^{\circ} 28'$  N. the density of the surface water is 1.0250, and is nowhere less than 1.0256 under the surface; as we cannot admit that in a region where density decreases with depth water rising to the surface should have its density reduced, we must assume that the lightness of the surface water is either due to precipitation or to a current of light water, the north equatorial, and that the water of the density of 1.0256 may not reach the surface, or, if at all, then probably far to the westward of the position indicated on the diagram.

A. LINDENKOHL.

#### THE STORING OF PAMPHLETS.

THE question of the best method of keeping pamphlets in a private library has become a question of great practical importance to the scientific worker. Owing to the custom of exchanging reprints of arti-



cles, it has come about that the larger part of a working scientific library is very apt to consist of separate pamphlets, which soon run up into the thousands in number. Many expedients have been suggested for arranging these so as to keep them always in strict order and at the same time readily accessible. The use both of drawers put in a cabinet, and of various forms of boxes, has been proposed from time to time, and each of these suggested plans has had something to recommend it.

I have now been using for some time a form of box which seems to me, on the whole to combine a larger number of advantages for the preservation and ready accessibility of one's pamphlets. This box is made of thin wood, and measures inside 7x4 inches, and is 10½ inches in height. It is entirely

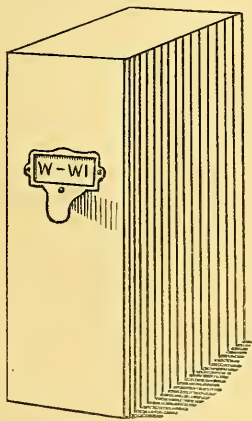

open at the back, and is covered with a cheap grade of marble paper. Pamphlet boxes of this form are furnished in quantity at low rates by the Library Bureau.\* By simply adding to each of these a pull and label holder, as shown in the figure, we ob-

tain a box which may be placed on a shelf of an ordinary book-case, and which may be easily pulled out from its position with one hand, leaving the other hand free to look over the pamphlets which it may contain. The label may be easily shifted in the holder, if the contents of the pamphlet-box are to be changed. These boxes may be arranged in rows upon a shelf, and then present a neat and orderly appearance, and whenever one box becomes too full another box may be interpolated in the series without difficulty.

As regards my own system, I arrange the boxes in two sets. In one of these sets the pamphlets are arranged alphabetically according to the author, and in this series I include all such publications as refer to my special line of study. In a second set each box is devoted to a special subject, and here are placed pamphlets which I have less frequent occasion to refer to. I find it also very convenient to keep journals and magazines in these boxes, a separate box for each magazine. These serials are then kept in good order, are protected from dust and are readily accessible.

In conclusion, I will only say that, after having experimented with many systems, I have found this the most simple, convenient and economical, and, therefore, on the whole, the most satisfactory of any which I have tried.

CHARLES S. MINOT.

#### NOTES ON INORGANIC CHEMISTRY.

THAT there is a decided resemblance between the compounds of oxygen and halogen salts with ammonia, and the compounds of these same salts with water was long ago pointed out by Professor H. Rose. This fact is further developed by Mendeleef in his 'Grundlagen der Chemie,' and attention is there called to the fact that many of these salts give up a part or the whole of their ammonia in a very similar way to that

\* The Library Bureau, 530 Atlantic Ave., Boston, Mass.

in which they give up their water of crystallization. A typical example is copper sulfate, which not only forms the compounds,  $\text{CuSO}_4$ ,  $5\text{H}_2\text{O}$  and  $\text{CuSO}_4$ ,  $5\text{NH}_3$ , but also the four intermediate compounds,  $\text{CuSO}_4$ ,  $4\text{H}_2\text{O}$ ,  $\text{NH}_3$ ;  $\text{CuSO}_4$ ,  $3\text{H}_2\text{O}$ ,  $2\text{NH}_3$ ;  $\text{CuSO}_4$ ,  $2\text{H}_2\text{O}$ ,  $3\text{NH}_3$  and  $\text{CuSO}_4$ ,  $\text{H}_2\text{O}$ ,  $4\text{NH}_3$ , so that the replacement of water by ammonia is not a mere figure of speech. In the last number of the *Zeitschrift für anorganische Chemie*, Fritz Reitzenstein takes up the replacement of water by other nitrogen bases, especially pyridin, and shows that a large number of salts form similar compounds with pyridin, as with water of crystallization. Some of these were known before, but twenty-eight new ones are described, as well as several compounds in which quinin replaces the water of crystallization. A table is appended to his paper giving several hundred of the known hydrates, ammonia compounds and pyridin compounds in juxtaposition, and the resemblance of the typical members of each group is striking.

In the previous number of the *Zeitschrift*, Reitzenstein's 'Habilitationsschrift' is published, which is a very complete history of the different theories of the constitution of the metal-ammonia salts. The first notices of the combinations of certain salts with ammonia date back to Bergman and Tassaert in the last century, but no particular attention was attracted to them until the discovery of the first platinum-ammonia compound by Magnus in 1828. This was quickly followed by the preparation of new platinum bases by Gros (1838), Reiset (1840-1844), Peyrone (1844), Raewsky (1847) and Gerhardt (1850). As early as 1841 Berzelius attempted to explain their constitution according to his general theory of salts, but Claus was the first who held the view accepted to-day that the ammonia is present in the compound as the  $\text{NH}_3$  group. This was brought into accord with the valence theory by Jörgensen, of Copen-

hagen, who has been the most prolific worker in the metal-ammonia compounds, and until recently his views, which represent the ammonia groups as united with each other, as  $-\text{NH}_3 - \text{NH}_3 - \text{NH}_3 - \text{NH}_3 -$ , has been generally accepted. Here the ammonia is often replaced by water, in which case the oxygen is looked upon as quadrivalent. In some series, as among the platinum and cobalt bases, isomers are met with, and some of them are difficult to account for by Jörgensen's theory. Within the present decade Alfred Werner, of Zurich, has proposed a new theory, which represents the atom of the metal as in the center of an octahedron, surrounded by six other atoms or groups (as  $\text{NH}_3$  or  $\text{H}_2\text{O}$ ), one at each angle. In some cases there are but four attached atoms or groups, in which case the configuration can be represented as on a plane with the metal atom in the center of a square and one group at each of the four angles. This complex is supposed to have a certain amount of combining power as a whole, and unites with negative or positive elements to form salts. Werner carries this theory out in application to many other classes of salts, as, for example, sulfuric acid, where the complex  $\text{SO}_4$  is united with two atoms of hydrogen; potassium permanganate, where the complex  $\text{MnO}_4$  is united to one atom of potassium;  $(\text{HgCl}_4)\text{K}_2$ ,  $(\text{PtCl}_6)\text{K}_2$ ,  $(\text{SiF}_6)\text{K}_2$ , etc. The idea of valence is not wholly abandoned, but is not adhered to in the formation of the complex. The theory is too new to prophesy whether it will meet with general acceptance, but in its application to the platinum and cobalt bases it explains much that is difficult to account for on the valence theory as ordinarily accepted. Reitzenstein's paper and recent papers by Werner should be consulted for the full explanation of the theory.

In this connection it may be noted that the resemblance of water to ammonia is not

confined to such cases as those mentioned. The production of liquid ammonia in quantity has led to its investigation as a solvent, in which it resembles water to some considerable degree. Salts render it a conductor of electricity and a similar dissociation seems to take place as in aqueous solution. In the December number of the *American Chemical Journal* E. C. Franklin and C. A. Kraus record the solubilities of something over five hundred substances, inorganic and organic, in liquid ammonia in which many analogies with water are shown. They also give the determinations of molecular rise in boiling-point of liquid ammonia for twenty-nine different substances.

J. L. H.

#### CURRENT NOTES ON METEOROLOGY.

##### UPSALA CLOUD OBSERVATIONS.

THE first publication embodying the results of the International Cloud Observations comes from Upsala, where Dr. Hildebrandsson carried on the work during the International Cloud Year (May 1, 1896–May 1, 1897). According to *Nature* (Dec. 1) nearly 3,000 measurements of heights and velocities were made, 1,635 of which were made by means of photography. The annual variation of the mean heights of the clouds is very marked, the maximum coming in June and July, and the minimum in the winter. During the summer the mean height of the cirrus is 8,176 meters, and of the cumulus 1,685 meters. The heights of the upper and middle level clouds are lower than at Blue Hill Observatory. The velocity of all the clouds is greater in winter than in summer.

##### RECENT ANEMOMETER STUDIES.

AT the meeting of the Royal Meteorological Society, held in London, November 16th, a report on the exposure of anemometers at different elevations was presented by the Wind Force Committee. The experiments

were carried out by Dines and Wilson-Barker, on board H. M. S. *Worcester*, off Greenhithe. Five pressure-tube anemometers were employed, the first being at the mizzen royal masthead; the second and third at the ends of the mizzen topsail yard-arm, and the fourth and fifth on iron standards 15 feet above the bulwarks. The results show that the ship itself affected the indications of the lower anemometers, while some low hills and trees, which were a quarter of a mile away from the ship, to the south and southwest, also affected the wind velocity from those quarters. The Committee are of the opinion that the general facts deducible from these observations bearing on the situation of instruments for testing wind force are: (1) That they must have a fairly clear exposure to be of much value, and it would appear that for a mile, at least, all around them there should be no hills or anything higher than the position of the instruments. (2) That on a ship the results may be considered fairly accurately determined by having the instrument 50 feet above the hull, but that on land it will generally be necessary to carry the instrument somewhat higher, to be determined entirely by local conditions. (3) That no other form of anemometer offers such advantages as the pressure-tube, from the fact that it can be run up and secured easily at this height above a building, and that the pipes and stays can be so slight as to offer no resistance to the wind or cause any deflecting currents.

##### SAN FRANCISCO RAINFALL.

A PAPER by Marsden Manson in the October number of *Climate and Crops, California Section*, concerns the seasonal and monthly rainfall at San Francisco from 1849 to 1898. In this period of forty-nine years the normal annual rainfall has been 23.4 inches. Fluctuations have occurred between an annual rainfall of 7.4 inches in 1850–51, and



of 49.2 inches in 1861-62. The rainfalls of the winters of 1850-51, 1862-63, 1863-64, 1870-71, 1876-77 and 1897-98 have been the smallest, averaging 10.8 inches. Five seasons have had an average rainfall of 40.89 inches, viz., 1852-53, 1861-62, 1867-68, 1877-78, 1889-90. The variations in winter rainfall are stated to be due primarily to the changes in the positions of the lines upon and along which the areas of low pressure originate and move in their course from the North Pacific Ocean into the interior of the continent.

#### FREQUENCY OF RAINY DAYS IN THE BRITISH ISLES.

THE British rainfall records for the period 1876-1895 have been studied by Scott, in order to determine the frequency of rainy days in the British Isles (*Quart. Journ. Roy. Met. Soc.*, Oct., 1898). Charts have been drawn showing the mean monthly frequency of rainfall in percentages. The greatest excess of frequency is always on the extreme north and west Atlantic coasts. The highest figures of all are found at Dunrossness (Shetland) and at Stornoway in most months, especially in the late autumn and winter. In summer the figures for the west of Ireland are higher.

R. DEC. WARD.

HARVARD UNIVERSITY.

#### CURRENT NOTES ON ANTHROPOLOGY.

##### MAN AND MONKEY.

UNDER the title 'L' Homme et le Singe,' the Marquis de Nadaillac, in the *Revue des Questions Scientifiques*, October, 1898, gives a thorough and searching criticism of the alleged descent of man from the anthropoids. He points out forcibly how many assumptions, without positive support, underlie the general theory of evolution, and especially the evolution of man from any known lower type. At the same time, he does not pretend that our present knowledge

is decisive, either for the negative or the affirmative. "At the present time," he says, "in view of what is actually known, we are not prepared to deny the possibility of any such theory; but, I hasten to add, we are just as little prepared to affirm it as a truth." Such caution is certainly in season, as the tendency is constant to hasty conclusions.

#### THE NATIVE TRIBES OF COSTA RICA.

AN interesting contribution to the anthropology of Costa Rica has recently been published by Dr. H. Pittier (*Razas Indigenas de Costa Rica*, 1<sup>a</sup> Contribucion, November 1898). He furnishes a number of anthropometrical data of the Guatusos Indians and a newly collected glossary of their language. Diagrams of their feet and hands are added. There are wide variations in all the physical measurements, illustrated by the pulse-rate, which varies from 58 to 87, and by the skull-form, which is dolicho-, meso- or brachy-cephalic. Dr. Pittier concludes, "that it is not possible from these data, which display such marked divergences, to establish a definite type for the race." The vocabulary is especially useful for the careful study of the sounds of the language which accompanies it.

#### THE CHRONOLOGY OF ARCHEOLOGY.

FEW questions in pre-historic archæology are of greater interest than the means of determining the positive chronology of its various epochs and periods. A distinctly valuable contribution to this point is one by Dr. Robert Munro in the *Archæological Journal*, September, 1898, entitled 'The Relation between Archæology, Chronology and Land Oscillation in Post-glacial Times.' He assumes the probability of the astronomical theory of glacial causation and also the generally admitted opinion that the maximum cold in each glacial period coincided with the maximum submergence of land. With these as guides, he reviews the evi-

dence for submergence in a number of localities in Europe, and concludes that the amelioration of the climate began about 30,000 years ago, 'which synchronizes with the astronomical calculations to marvellous nicety.'

#### ETHNOGRAPHY OF GERMAN EAST AFRICA.

THE Germans set a good example by their investigations of the native tribes in their newly acquired possessions. An instance of this is an article by Dr. F. von Luschan on the Wassandau, Warangi, Wambugwe and neighboring peoples of German East Africa. It is amply illustrated and presents a clear idea of their general stage of culture. Among other curious facts mentioned is one explaining the rapid diminution of the tribe known as the Wataturu. The men of this tribe are industrious and accustomed to do the work which in neighboring tribes is performed by the women; hence, they are in great demand in these tribes as husbands, and, as the rule is that they follow their wives, their own tribe diminishes. (*Beiträge zur Ethnographie des abflusslosen Gebiets von Deutsch-Ost-Africa*, Berlin, 1898.)

D. G. BRINTON.

UNIVERSITY OF PENNSYLVANIA.

#### SCIENTIFIC NOTES AND NEWS.

TWELVE scientific societies, representing more than half of the most important scientific work accomplished in America, are beginning their meetings at Columbia University as we go to press. We have already called attention to the dates and other arrangements for these meetings, and full reports of the proceedings of the different societies will be given in subsequent issues. The address of Professor Bowditch, President of the American Society of Naturalists, is published in this number, and other important addresses and papers will follow.

THE International Astronomical Society appears to have held a successful meeting at Buda-Pesth, though it scarcely deserves the

name 'international' when American, English and French astronomers are unrepresented at its meetings. The existing organization might, however, be developed so that international congresses could be held as important as those in mathematics, zoology, geology, physiology and psychology.

A CABLEGRAM from London announces that Lord Iveagh (Edward Cecil Guinness) has presented to the Jenner Institute of Preventive Medicine, London, the sum of £250,000, in aid of scientific research in bacteriology and other branches of biology, concerned with the cause, nature, prevention and treatment of disease.

THE Regents of the University of the State of New York have decided to divide the work in geology and paleontology which was for so many years in charge of the late Professor James Hall, and in so doing have erected two co-ordinate departments, one of paleontology and stratigraphic geology and the other of 'pure geology,' the latter to cover dynamic and physical geology, the crystalline rocks, surficial geology, etc. They have appointed to the charge of the former Professor John M. Clarke, with the title of State Paleontologist, and to the latter Dr. F. J. H. Merrill, with the title of State Geologist. They have also appointed Dr. E. P. Felt to the position of State Entomologist as successor to the late Dr. J. A. Lintner.

PROFESSOR E. B. WILSON, of Columbia University, whose departure for Europe on a year's leave of absence we recently announced, intends to visit the Nile region in order to study, if possible, the embryonic stages of the African ganoid *Polypterus*, the supposed ancestor of the Amphibia. Those who read Dr. Harrington's article in this JOURNAL will remember that he and Dr. Hunt found this fish in the Nile last summer, but were unable to wait for the breeding season.

M. GRAVIER has been made Assistant in the Paris Museum of Natural History in the room of the late M. Bernard.

THE University of Marburg has conferred the degree of Ph.D. *honoris causa* on Professor J. M. Clarke, of Albany.

PROFESSOR ERIC GERARD, of the University of Liège, known for his contributions to elec-

tricity and magnetism, has been admitted to the Belgian order of Leopold.

THE Paris Academy of Sciences has awarded the Desmazières prize to Dr. J. B. de Toni for his *Sylogæ Algarum*.

THE Paris Anthropological Society has chosen Dr. Capitan as President for 1899.

DR. J. KOLLMAN, professor of anatomy in the University of Basle, has been elected a member of the Munich Academy of Fine Arts.

SIR WILLIAM JENNER, F.R.S., the eminent physician, died on December 11th, in his eighty-third year. He was for many years professor, first of pathological anatomy and later of medicine, at University College, London. He had published works on fevers and other subjects.

THE death is also announced of M. Jacques Passé, an assistant in the laboratory of physiological psychology at the Sorbonne, Paris, known for his researches on the sense of smell, etc.

THE death of Mr. Hayter Lewis, formerly professor of architecture in University College, London, deserves mention in this place, if only because he was one of the first to recognize relations between sanitary science and architecture. We also regret to record the death, at the age of 73, of M. Laboulbène, since 1879 professor of the history of medicine and surgery, at Paris.

THE Paris Exposition of 1900 will include a museum of the history of chemistry. It will include apparatus, products of chemical laboratories, plans, portraits of investigators, etc.

It is stated in *Nature* that an informal committee will shortly meet in Calcutta to consider the reports by the Astronomer Royal and Sir Norman Lockyer, who were recently asked for advice regarding Indian astronomical and solar observatories. The future working of these observatories will be discussed, and Sir James Westland, Messrs. T. Holderness and J. Eliot, and General Strahan, Surveyor-General, will probably be members of the committee.

MR. MICHAEL LAKIN'S donation of a large Liassic *Ichthyosaurus* to the British Museum, says *Natural Science*, has necessitated a considerable rearrangement of the existing collection.

We understand that the old cases are to be removed, while the fine slabs containing these fossils will be simply covered with glass and exhibited upon the wall. Space is to be gained by raising a number of the specimens above the top of the present wall-cases.

It appears that the School of Tropical Medicine, at London, to which we have several times recently called attention, will receive a subsidy from the British Treasury on behalf of the Protectorates under the administration of the Foreign Office.

CAPTAIN BORCHGREVINK'S expedition, which left London on August 3d, has started from Hobart, Tasmania, for the Antarctic regions.

GENERAL VÉNUTCOFF announces that a Russian expedition will shortly leave for Spitzbergen to make geodetic and astronomical observations.

THE steam yacht *Utowana* left New York on December 24th for Yucatan on the botanical expedition to which we have already called attention. Dr. C. F. Millsbaugh, of the Botanical Department of the Field Columbian Museum, is in charge, and the party includes Mr. A. V. Armour, the owner of the yacht.

*Nature* states that owing to the unique and extremely interesting nature of the fauna in Lake Tanganyika, the study of which was recently the object of an expedition supported by the Royal Society, and led by Mr. J. E. S. Moore, a committee has been formed, consisting of Sir. John Kirk, G.C.M.G., K.C.B., F.R.S. (late British Resident at Zanzibar); Dr. P. L. Sclater, F.R.S. (Secretary of the Zoological Society); Mr. Thiselton-Dyer, C.M.G., F.R.S. (Director of the Kew Gardens); Professor Ray Lankester, F.R.S. (Director of the Natural History Departments of the British Museum), and Mr. G. A. Boulenger, F.R.S. (of the British Museum), for the purpose of organizing another expedition to the same regions, to thoroughly survey the basin, not only of Lake Tanganyika, but also the unknown portions of the northern extension of the great series of valleys in which Tanganyika, together with Lakes Kivu and the Albert Nyanza, lie; to collect specimens of the aquatic fauna and flora and to study the geological history of this part



of Africa. The sum of £1,000 has been subscribed from one source towards the expenses of the expedition, which are estimated at not less than £5,000.

THE Washington Academy of Medicine held its sixth annual meeting on December 14th, when Dr. Samuel C. Bussey delivered the presidential address, on 'The History and Progress of Sanitation of the City of Washington and the Efforts of the Medical Profession in Relation Thereto.'

THE New England Association of Chemistry Teachers will hereafter publish records of its meetings. We have received a report of the nineteenth meeting, held in Boston on November 12th. Dr. H. M. Goodwin, of the Massachusetts Institute of Technology, read a paper on the advance in physical chemistry during the last decade, and a report was presented on the progress of the movement instituted by the Association to promote efficiency in the teaching of chemistry.

THE second annual convention of the directors of physical education of the colleges and universities of the United States will be held at Columbia University, New York, on December 30th.

M. DUSSAUD, of Geneva, has sent the Paris Academy of Sciences a description of a new telephone with which he has successfully experimented. From a distant laboratory he was able to send messages that could be distinctly heard in a large room by an audience of 1,000 people.

MR. A. B. BAKER, of the National Zoological Park, notes that the large snakes refuse to eat rats captured about the buildings, but quickly devour those caught out of doors. Rats taken indoors were then kept for a day or so in a cage with an earth floor, after which they were readily eaten. A very similar experience was had with smaller snakes, copperheads, these declining to eat house mice, permitting them to run about the cage, or even over their bodies, with impunity, while field mice were quickly taken even after they had been dead for some little time. These facts seem to show that snakes have a very keen sense of smell and are largely guided by it in the choice of their food.

PROFESSOR BEHRING, in conjunction with Dr. Ruppel, has applied for a German patent for a tuberculosis serum: 'A method for producing a highly poisonous and immunifying substance from tubercle bacilli or from cultures of tubercle bacilli.'

THE Prince of Wales presided at a private meeting at Marlborough House, on December 20th, convened by him to promote a war against tuberculosis. The Marquis of Salisbury, the Earl of Rosebery and a number of men of science and physicians spoke on the urgent necessity of educating the people in the means of preventing consumption and of checking the spread of tuberculous disease among cattle.

REUTER'S agency states that advices from the Russian provinces of Livonia and Courland report that leprosy is spreading to a marked extent. The military authorities in these districts have been compelled to reject for the army many young men found to be infected with the disease. Notwithstanding the precautions taken, the number of victims amounts at the present time in Russia to more than 5,000.

GIVING evidence before the Plague Commission, at Bangalore, on December 12th, Colonel Robertson, the Resident at Mysore, stated, according to the London *Times*, that the attitude of the people was uncompromisingly hostile to the plague measures. It was impossible in the large cities to deal effectively with the epidemic, the fear of which destroyed natural affection. Captain Roe, chief plague officer, maintained that segregation was unsuccessful, owing to the difficulty of catching the people; if segregation were abolished the natives would not run away. Major Deane declared that Yersin's serum was useless. Haffkine's serum, he said, conferred a temporary immunity, but not to the extent supposed. Colonel McGann stated that the plague had been prevalent among native soldiers, but not among the Europeans. Haffkine's prophylactic had been found valuable. The plague was in the middle of December again increasing in Bombay city, but a decrease was reported in the Presidency districts. Madras, Mysore and Haidarabad remain unchanged, but a number of cases have occurred in the Central Provinces.

We learn from the *British Medical Journal* that the Nizam's government has sanctioned the immediate construction of a complete and thoroughly-equipped Pasteur Institute for Haiderabad. It will adjoin the hospital and medical school, and will be available in about six months for patients. The Colombo Pasteur Institute, which is being constructed near the Lady Havelock Hospital out of funds towards which Mr. J. W. C. De Soysa contributed 10,000 Rs. in memory of his father, is approaching completion, and will be opened probably early next year. Meanwhile the Pasteur Institute for India hangs fire, and the delay is calling forth some expression of impatience on the part of subscribers.

DR. CROSBY, of the New York City Board of Health, has given out the following statistics of deaths from influenza in the city :

	1890.	'91.	'92.	'93.	'94.	'95.	'96.	'97.	'98.
Jan .....	264	1	281	5	71	242	16	10	—
Feb .....	30	—	109	4	33	165	18	28	8
March.....	12	45	50	47	29	84	17	64	19
April .....	3	507	20	86	16	44	26	51	16
May.....	1	123	13	30	5	15	5	21	2
June.....	2	34	3	9	6	2	—	4	2
July.....	—	4	1	—	4	—	1	1	2
August...	—	3	—	—	1	1	1	—	—
Sept.....	—	—	—	2	—	—	—	2	—
Oct. ....	—	4	—	4	4	2	2	2	—
Nov.....	1	4	13	5	6	4	4	3	12
Dec. ....	1	129	5	35	13	8	11	10	?
Totals..	314	854	495	227	188	567	101	196	58

The mortality attributed to other sources has also been greatly increased during epidemics of 'the grip.' It appears that the disease grows in severity for two or three months, and the outlook for New York and other cities is consequently unfavorable. Until December, 1889, when the disease was imported from Europe, having apparently traveled from China to Russia, there had been no epidemic since 1849.

The question has of late been often raised among professional men whether it would not be wise and practical to seek to evade many of the difficulties and objections arising from the employment of 'experts' by litigants on both sides, leaving Court and jury to gather the es-

sential facts and the technical merits of the case, as best they can, from prejudicial and admittedly partisan testimony, the usual suggestion being the appointment by the Court of its own experts. We find in '*Der Ingenieria*' of Buenos Ayres, 1898, pp. 91-102, an account of the investigation of the cause of a steam boiler explosion by the National Railway Board, in the course of which a detailed report was submitted by independent experts appointed by the Courts. It would seem that Argentina has progressed further in this direction than the United States.

PROFESSOR H. H. TURNER, of Oxford University, makes the breaking of windows at the Observatory by small boys the occasion of a renewed appeal for a house for the director in the park near the Observatory. He says: "It was in the last few months of my chief assistantship at Greenwich that the anarchist Bourdin made his attempt to blow up the Royal Observatory; and the attempt, unsuccessful as it fortunately was, could not fail to impress those immediately concerned as to the necessity for carefully protecting an observatory isolated in the middle of a park. I do not wish to compare the mischievous boyish freak of yesterday with this grave and dastardly outrage; but there is this common to the two—that the opportunity was selected with reference to the absence of people from the spot. Bourdin selected a time when the Astronomer Royal was away and the staff would ordinarily have left the Observatory (though, as a matter of fact, one or two were on the spot, having stayed beyond the usual closing hour to finish some work); the boys with catapults found Sunday afternoon a good time to use them."

#### UNIVERSITY AND EDUCATIONAL NEWS.

THERE seem to be difficulties in arranging for the accommodation of the University of London, in the buildings of the Imperial Institute. In the meanwhile the Council of University College have notified the Statutory Commission that they are prepared to consider placing the land, buildings and endowments of the College at the complete disposal of the Commission.

AN organization, 'La société des amis de l'Université,' has been formed in Paris and adopted a constitution on December 11th. The object of the Society is to aid in the development of the University of Paris, by forming new chairs, assisting the laboratories, establishing scholarships, prizes, etc. It is proposed to issue a bulletin especially in the interests of the students.

DR. THOMAS EGGLESTON, emeritus professor of mineralogy and metallurgy in Columbia University, has presented to the University his library and mineralogical collection. The former is especially rich in serials; the latter contains about 5,000 valuable specimens.

MR. CHARLES WHEELER, of Philadelphia, has given \$5,000 to Harvard University in memory of his son, Stuart Wadsworth Wheeler, '98, who served in the Porto Rican campaign, and died in Boston a short time ago. The money will be invested, and the interest used as a loan fund in the Lawrence Scientific School.

PRESIDENT WARFIELD has announced a gift of \$10,000 to Lafayette College. It is also reported that a gift of \$50,000 has been made for the Chemical Laboratory.

IT is proposed to establish, as a memorial to Sir Robert Peel, a scholarship in the Technical School at Blackburn. Mr. Yerburch has opened the fund with a donation of £1,000.

DR. JAMES LITTLE has been nominated regius professor of medicine in the University of Dublin in the place of Sir John Banks.

PROFESSOR RÖNTGEN, of Würzburg, has declined the call to Leipzig as the successor of Professor Wiedermann.

#### DISCUSSION AND CORRESPONDENCE.

##### THE ORIGIN OF MAMMALS.\*

THE question under discussion is not new, but one of a series of similar nature and difficulty. The origin of birds, of reptiles, of amphibians and of fishes really precede it, and offer less difficulties in solution. The answer

\* Remarks in the general discussion on the Origin of Mammals, at the International Congress of Zoology, Cambridge, England, August 25, 1898.

to each, in my opinion, belongs to the future, and how far it may profitably be sought in the present limited state of our knowledge is a fair question in itself.

Too often in the past a discussion on the origin of mammals has seemed a little like the long philosophico-theological controversies in the Middle Ages about the exact position of the soul in the human body. No conclusion was reached, because, for one reason, there were no facts in the case that could settle the question, while the methods of investigation were not adapted to insure a satisfactory answer. The present discussion is on a much higher plane, and the previous speakers have made an admirable presentation of their side of the case. I cannot, however, quite agree with them as to the value of the facts and theories they have presented, and shall consider the question from another point of view.

The mammals, as we know them to-day, are classed by themselves, yet contain such diverse groups that it may fairly be regarded an open question whether all have a common origin. The attempt to ascertain whence they came is likely to bring out indications that they may have had several sources of origin, and this, if so, may help to explain the great diversity among them.

It is, of course, evident that some of the most characteristic features of recent mammals, for example, the hairy covering, the circulatory system and the milk glands, cannot be used in a comparison with fossil forms. The osseous structure only is now available in the early mammals and other vertebrates, and in this alone points of resemblance must be found if different groups are connected genetically.

In considering the relations of reptiles to mammals so far as the fossil forms are concerned, which seems to be the main question before us to-day, I have only time to speak of the skull, and shall refer to some of its salient features already mentioned in this discussion, namely, the teeth, the squamosal bone, the quadrate, the occipital condyles, and with them the lower jaw. These, perhaps, may serve as crucial points in distinguishing the skull of a reptile from that of a mammal, even if they fail to indicate a near affinity between them.



The different kinds of teeth seen in the reptiles regarded as mammalian in type I consider of comparatively small importance, for the reason that the same general forms of teeth are to be found, not merely in the reptiles supposed to be nearest to mammals, but also in other groups widely different. In the crocodiles, for example, the extinct genus *Notosuchus*, recently discovered in Patagonia, has all three kinds of teeth well distinguished. Again, some of the Dinosaurs, especially the genus *Triceratops*, have teeth with two rows, a supposed mammalian character. In some fishes, also (*Anarrhichas*), three kinds of teeth may be seen. It is more than probable, therefore, that the peculiar resemblance between the teeth of mammals and those of the lower vertebrates is merely one of parallel development, the adaptation being along similar lines, and in no sense an indication of genetic affinity.

The great development of the squamosal bone in Theriodonts is not seen in them alone, for somewhat similar proportions are found in other reptiles, for example, in the Plesiosaurs, where the squamosal is very large, and wrapped around the quadrate. In some of the Dinosaurs, also (*Torosaurus*), the squamosal has an enormous development, while the quadrate remains of very moderate size.

The quadrate bone, always present in birds, reptiles and other lower vertebrates, is well known as the suspensorium of the lower jaw, which meets it with a concave articular face. The quadrate, however, appears to be wanting in mammals, or at least has not yet been identified with certainty.

What represents the quadrate bone in mammals is a vexed question in itself, and some of the best anatomists in the past, Cuvier, Owen, Peters, Huxley and others, have endeavored to solve the problem. The tympanic bone, the incus and the malleus have each in turn been regarded as the remnant of the quadrate, but up to the present time the question has not been settled. It is not improbable that the quadrate may have coalesced with the squamosal.

The occipital condyles of mammals, as well known, are two in number, and separated from each other. This is not the case with any true

reptile, although the contrary has been asserted. The nearest approach appears to be where there is a single bifid condyle, cordate in shape, with the two lobes meeting below, as in some reptiles and a few birds, but not separate as in mammals and amphibians.

Finally, in all known mammals, recent and extinct, the lower jaw is composed of a single piece, and has a convex condyle meeting the skull by a distinct articulation. All reptiles, even those supposed to be nearest the mammals, have the lower jaw composed of several pieces, and these show distinct sutures between them, a profound difference that must be explained away before an approach can be made between the two classes.

It may fairly be said that the separate elements of the lower jaw, if present, would naturally be looked for in the Mesozoic mammals, and this point I have long had in mind. I may safely say that I have seen nearly every species of Mesozoic mammals hitherto described, and have searched for evidence on this point without success. I have also sought for the separate elements in the young of recent forms, but without finding any indications of them.

Beside the crucial points I have mentioned in the skull, there are others of equal importance in the skeleton, which I must not take time to discuss, but will venture to allude to one of them in passing. I refer to the ankle joint, which, when present, is at the end of the tibia in mammals, but in reptiles between the first and second series of tarsals. When we really find an approach between these two classes the ankle joint will probably show evidence of it.

Having thus shown, as I believe, that we cannot, with our present knowledge, expect to find the origin of mammals among the known extinct reptiles, and that in attempting this we are probably off the true line of descent, it remains to indicate another direction in which the quest seems more promising.

Since 1876, when Huxley visited me at New Haven, and we discussed the probable origin of both birds and mammals, I have been greatly impressed by his suggestion that the mammals were derived from ancestors with two occipital condyles, and these were doubtless primitive

amphibians. I have since sought diligently for the ancestors of birds among the early reptiles, with, I trust, some measure of success, but this is a simple problem compared with the origin of mammals which we have before us to-day.

In various interviews with Francis Balfour, in 1881, at the York meeting of the British Association, we discussed the same questions, and agreed that the solution could best be reached by the aid of embryology and paleontology combined. He offered to take up the young stages of recent forms, and I agreed to study the fossils for other evidence. His untimely death, which occurred soon after, prevented this promised investigation, and natural science still suffers from his loss. Had Balfour lived he might have given us to-day the solution of the great question before us, and the present discussion would have been unnecessary.

The birds, like the mammals, have developed certain characters higher than those of reptiles, and thus the two classes seem to approach each other. I doubt, however, if they are connected genetically, unless in a very remote way.

Reptiles, although much lower in rank than birds, resemble mammals in various ways, but this may be only an adaptive likeness. Both of these classes may be made up of complex groups only distantly related. Having both developed along similar lines, they exhibit various points of resemblance that may easily be mistaken for indications of real affinity.

In the amphibians, especially in the oldest forms, there are hints of a true relationship with both reptiles and mammals. It seems to me, therefore, that in some of the minute primitive forms, as old as the Devonian, if not still more ancient, we may yet find the key to the great mystery of the origin of mammals.

O. C. MARSH.

#### ZOOLOGICAL BIBLIOGRAPHY.

TO THE EDITOR OF SCIENCE: I am glad to see from Mr. Bather's letter in SCIENCE (No. 207) that the recommendations of the Committee on zoological and botanical publications are not what one would be justified in inferring from the printed abstract on which my remarks were founded. All zoologists are under obligations to Mr. Bather and his associates for their labors

in the more arid, but not the less essential, branches of the subject. We hope to be still more grateful to them when their present task is completed, and, therefore, avail ourselves freely of the invitation to criticise the incomplete work in order that the completed structure may become more universally acceptable.

Nevertheless, I find even in his new presentation of the subject a lingering trace of the assumption that certain things are settled which do not appear to me to be determinate. What is the definition adopted by the committee of the phrases 'distributed privately' and 'published in the regular manner'? Upon this depends whether all that follows may be acceptable or not. How many is 'a few'? What is 'public' and what is 'private'? This sort of thing should not be left doubtful. The answers are by no means a matter of course.

When an author, to avoid two or three years' delay, pays for the prompt publication of his researches he does not, in my experience, lock up his copies in a safe and take his name out of the Naturalist's Directory. On the contrary, he at once distributes copies to the journals interested in his branch of science and to the experts in his special line, and sends a copy to Friedländer for the *Natura Novitates*, where it is advertised at a price. If he should omit the latter (a most improbable suggestion), and the paper is of interest, he will certainly be called on and glad to furnish copies to those desiring them. The author who does not desire publicity for his work, and has no known address, in my opinion is a myth. Why otherwise should he print at all?

I quite agree that the paper must be made available to those who wish to purchase it, but I do not for a moment admit that this must be solely through the Society in whose Proceedings it sees the light.

How about the highly genteel persons who publish in *éditions de luxe* of 100 copies? Such works are frequently far more inaccessible than those separata distributed by authors.

It seems to me that the committee would do well to state in the fullest detail their ideas of what constitutes publication and how this shall be registered.

My own opinion is that the sort of thing crit-

icised by Mr. Bather is very rare, if not entirely non-existent. In a tolerably active and rather long experience I have never known of an instance of the sort he mentions. Of course, there may be such, but in the lines I am familiar with I have never come across one.

Of far more practical importance to workers are the concealment by Societies of the true date of issue of their publications and the false dates of some well-known periodicals. Glaring instances of this unscientific procedure will occur to everybody. This is an evil which the committee would be generally supported in denouncing. Every issue of a periodical, or, better, every signature, should have the actual date of printing upon it. When this is delayed until a whole volume is printed the possessor of an extract is left in the lurch. The dating would cost nothing to the Societies and would often save the isolated worker hours of weary labor.

WM. H. DALL,<sup>1</sup>

SMITHSONIAN INSTITUTION, December 21, 1898.

LEHMAN AND HANSEN 'ON THE TELEPATHIC PROBLEM.'

TO THE EDITOR OF SCIENCE: Professor Titchener in to-day's SCIENCE assumes that Messrs. Lehman and Hansen have performed a work of definitive demolition in the well-meant article of theirs to which he refers. If he will take the pains to read Professor Sidgwick's criticism of their results in the S. P. R. *Proceedings*, Vol. XII., p. 298, as well as the note to my report of his paper in the *Psychological Review*, Vol. IV., p. 654, he will probably admit that, owing to the fewness of the data which they collected, they entirely failed to prove their point. This leaves the phenomena in dispute still hanging, and awaiting a positive interpretation from other hands.

I think that an exploded document ought not to be left with the last word, even for the sake of 'scientific psychology.' And I must incidentally thank Professor Titchener for his admission that 'aloofness, however authoritative' (which phrase seems to be *style noble* for 'ignorance of the subject, and be d—d to it'), is an attitude which need not be invariably maintained by the 'Scientific,' even towards matters

such as this. I only wish that his admission were a little less apologetic in form.

CAMBRIDGE, MASS.,

WILLIAM JAMES.

December 23, 1898.

SCIENTIFIC LITERATURE.

*Footnotes to Evolution.* A series of popular addresses on the evolution of life. By DAVID STARR JORDAN, PH.D., President of Leland Stanford Junior University. With supplementary essays by EDWIN GRANT CONKLIN, PH.D.; FRANK MACE McFARLAND, PH.D.; JAMES PERRIN SMITH. New York, D. Appleton & Co. 1898. Price, \$1.50.

Although the title of this book does not seem entirely self-explanatory or expressive, the lay reader will gain from a perusal of the volume a clear idea of what evolution means. He will also realize that what has been worked out in the world of animal life applies equally well in the main to man himself. Though man is an animal he is much more, and problems of existence arise in the social, moral and spiritual realms which are quite foreign to the subjects investigated by the zoologist only.

Dr. Jordan himself discusses, in a homely but clear and attractive and at times pithy and telling way, the 'kinship of life,' 'evolution: what it is and what it is not;' 'the elements of organic evolution;' 'the heredity of Richard Roe;' 'the distribution of species,' latitude and vertebræ;' finally attacking such subjects as 'the evolution of the mind,' 'degeneration,' 'hereditary inefficiency,' 'the woman of evolution and the woman of pessimism,' 'the stability of truth' and 'the struggle for realities.'

While the facts of organic evolution, or, to use Geddes' term, bionomics, are discussed in an interesting way, we have given us few new facts or views, but current facts, opinions and inferences are presented in a readable form. We should naturally have expected, in the chapter on the distribution of species, to be treated to the discussion of data drawn from a study of the animals of California, for the relation of the local varieties or incipient species to their environment is very striking on the Pacific coast, and could be made very interesting and suggestive to readers not possessing a special knowledge of the matter. To be sure,



the heads of some chipmunks of California, showing distinct species produced through isolation and very well drawn by Mr. W. S. Atkinson, forms the frontispiece, though we have been unable to find any reference to it in the text.

Dr. Jordan's own studies on the relation between latitude and the number of vertebræ contains many interesting facts, but these are not correlated with a number of similar cases of change in structure characterizing local varieties and races, which would throw more light on this attractive subject, though all these cases appear primarily to be due to local or comparatively restricted changes of the environment, and secondarily to isolation.

The chapter on 'the evolution of fossil cephalopoda,' by Dr. Smith, gives the results, some very striking, of long-continued studies on the evolution of these animals, and will be of much value to the specialist in paleontology. It is illustrated by five excellent plates.

The reviewer hardly feels qualified to pass judgment on the sociological chapters, but has enjoyed reading them and thinks that they merit attention, and will undoubtedly secure it from a wide circle of readers. They are all concerned with some of the burning questions of the day. The fancy sketch of 'the heredity of Richard Roe' is very well done. Based on the essays of Galton and others, with studies of his own, our author shows that the same conditions which have resulted in the formation of the English race will apply to such a colonial type as ours, and that in a few centuries "these same conditions will unite to form a 'Brother Jonathan' as definite in qualities and as 'set in his ways' as his ancestor, the traditional 'John Bull.'"

The chapters on 'the evolution of the mind,' 'degeneration,' 'hereditary inefficiency,' 'the woman of evolution and pessimism,' 'the stability of truth' and 'the struggle for realities' contain strong, wholesome thoughts presented in a clear, simple, homely style, which seem to us sound, progressive and most timely. When our race, and our people especially, wake up to and realize the strength and nature of the forces for evil, the tendencies to degeneration, and begin to battle with and overcome these—when that moment arrives, our nation need not fear the negro problem, the pauper phantoms of the

submerged thousands of our cities or the scandalous influence of our boss politicians. Then with the ever-growing strength resulting from long striving and experience in ruling the savage and barbarian elements actually among us, we can reach out and absorb, and perhaps turn to some good use, rather than exterminate, the millions of the barbarous and uncivilized of the Philippines, which have suddenly drifted in upon us as the wreckage of war.

A. S. PACKARD.

*Earth Sculpture or the Origin of Land-forms.* By JAMES GEIKIE. New York, G. P. Putnam's Sons. 1898. Illustrated.

The editors of *The Science Series* are fortunate in their selection of the author of this volume. Dr. James Geikie, Murchison professor of geology in the University of Edinburgh and author of 'The Great Ice Age,' is one of the ablest and best known geologists in Europe. His wide acquaintance with geological phenomena, his experience as a teacher and his conservatism make him an eminently fit and safe person to follow into a field that has been explored of late years by so many enthusiasts.

We feel thankful, too, that the subject has been treated by a man who concerns himself with the processes and results of earth sculpture, and but little with the names that have of late years been so copiously showered upon them. Dr. Geikie tells us in the preface that he has 'made scant use of those neologisms in which, unfortunately, the recent literature of the subject too much abounds.' A glossary is given at the end of the work for such technical terms as are indispensable.

The volume does not pretend to be a textbook on physiography. Its scope is best indicated by the contents, which are briefly as follows:

Agents of denudation.

Land forms	}	in horizontal strata,
		in gently inclined strata,
		in highly inclined strata,
		in faulted regions,
		due to igneous action.

Rock character and land forms.

Land forms modified by	}	glacial action,
		æolian action,
		underground water.

Basins.

Coast lines.

Classification of land forms.

These subjects are necessarily treated briefly owing to the limitations imposed by the size of the book, but they are all treated ably, and as the reader leaves each topic behind he feels that the author has not pumped his reservoir of knowledge dry.

If one wishes to find fault with a topographic map he need only go into greater detail or use a larger scale than was used by the maker of the map; if one would find fault with a book of this kind he needs only go a little further into the details of the processes and results under discussion. On this principle one may venture the following criticisms:

On page 46 the author says that the three main factors determining land forms are: (1) original slope; (2) geological structure; (3) character of the rocks. If he had cared to go into greater detail and finer subdivision of these factors he might have added to this list: (4) climatic conditions; (5) interruptions during development; (6) duration of exposure; (7) nature of denuding agency; (8) slope during development. Such subdivisions, however, are mere matters of convenience in discussion; the subjects themselves have not been overlooked.

It would have been well for American readers if the author had noted that the 'swallow-holes,' *dolinas*, 'kettle-valleys,' etc., spoken of on page 271 are known in this country as 'sink-holes.'

On pages 267-8 the author expresses the opinion that earthquakes may sometimes be caused by the falling-in of the roofs of caverns. To a person living in an earthquake region this seems to be an inadequate, or rather a highly exceptional, cause of earthquakes. Limestone regions are not generally looked upon as earthquake regions.

On page 284 æolian basins are mentioned 'as occurring in Arkansas.' These basins are not in Arkansas, but in the valley of the Arkansas River. In common with many other writers, he gets the name of *Rio de Janeiro* wrong (330, 332). To call it 'Rio Janeiro' is equivalent to calling a man Kinley when his name is McKinley. The editor may be warranted from analogy

in spelling *pulverise* so (pp. 30, 32), but neither Webster nor the Century gives such a spelling.

The illustrations are, on the whole, not up to the standard of the text. Most of them are smudged as if reproduced on the scale on which they were hastily drawn.

But these are all very small matters, and have little to do with the general merit of the book. It ought to be remembered, too, that Dr. Geikie is no mere maker of books. He is a busy scientific worker, who can find time only with great difficulty for writing a work of this character, and whatever one finds to criticise in this book is not to be attributed to any unfitness or unfamiliarity on his part with the subject he is dealing with.

Several references in the work to the relations of geology and earth-sculpture afford an occasion for referring to a doctrine being promulgated in this country of late years by enthusiasts on the subject of physiography, physical geography, earth-sculpture or whatever one may choose to name it, in the grammar and high schools, and even in the primary grades themselves.

Dr. Geikie says, on page 45: "So dominant, indeed, has been the influence of geological structure in determining the results worked out by erosion that without a knowledge of the structure of a country we can form no reliable opinion as to the origin of its surface features." At the end of the book he returns to this subject. On page 364 he concludes "that these (surface features) cannot be accounted for without some knowledge of geological structure." On page 367 he says: "It is almost impossible, indeed, to consider the formation of surface features without at the same time inquiring into their geological history. And not infrequently we find that the configuration of a land is the outcome of a highly involved series of changes. To understand the distribution of its hills and valleys, its plains and plateaux, and the whole adjustment of its hydrographic system, we may have to work our way back to a most remote geological period."

The book is made up of facts, almost every one of which is a silent witness to the correctness of this conclusion. Physiography is a study for mature minds, and it cannot successfully be

taught as a science to those who have no knowledge of geology. However much entertainment a boy or girl may get from dabbling in these subjects, for the common run of students they are university studies or studies for minds capable of doing university work.

JOHN C. BRANNER.

STANFORD UNIVERSITY, CALIFORNIA,

December 1, 1898.

*The Story of Photography.* By ALFRED T. STORY.

The Library of Useful Stories. New York, D. Appleton & Co. 1898.

In this little book of one hundred and sixty-five pages, which can be carried in the pocket, the author has gathered together an epitome of the gradual development of photography from the early attempts of Schultze in 1727 to the present day. The experiments of Wedgwood and Davy, Niépce, Daguerre, Fox, Talbot and St. Victor are given at length. An account of the usual printing processes, of photo-block printing and reproduction processes for illustrating, are included; also the recent application of the X-ray and the kinetoscope. There is just enough of physics and optics to enable the lay reader to form a good idea of the principles on which photography is based. 'The Story of Photography' reads easily and pleasantly, and it is doubtful if elsewhere in so small a compass can be found as comprehensive a description of an art that has so wide and varied applications. It will undoubtedly form a desirable addition to many private libraries.

E. L.

#### SCIENTIFIC JOURNALS.

*American Chemical Journal*, December. 'Camphoric acid.' By W. A. Noyes. In this paper, which is a continuation of former reports, the methods of preparation and the derivatives of xylic acid and xylidene are described. 'On some relations among the hydrates of the metallic nitrates.' By J. H. Kastle. Attention is called to the amount of water of crystallization of the different nitrates and the explanation that can be given for the complex and basic compounds. 'Liquid ammonia as a solvent.' By E. C. Franklin and C. A. Kraus. The solubility of about 400 substances has been de-

termined. 'Determination of the molecular rise in the boiling point of liquid ammonia.' By E. C. Franklin and C. A. Kraus. 'On the non-existence of four methenylphenylparatolyl amidines.' By H. L. Wheeler and T. B. Johnson. 'An active principle in millet hay.' By E. F. Ladd. 'Comparison of methods for estimating caffeine.' By E. F. Ladd. 'Creatin and its separation.' By E. F. Ladd and P. B. Bottenfield. 'A double citrate of zirconium and ammonium.' By S. H. Harris.

J. ELLIOTT GILPIN.

THE *Revue des Sciences Médicales*, an excellent quarterly journal, established twenty-six years ago and edited by M. Hayem, has been compelled to suspend publication. *L'Éducation Mathématique* is a new journal edited from Paris by Professors J. Griess and H. Vuibert.

#### SOCIETIES AND ACADEMIES.

THE PHILOSOPHICAL SOCIETY OF WASHINGTON.

THE 491st meeting of the Society was held at the Cosmos Club, December 10th, at 8 p. m. Mr. W. H. Dall spoke on the proposed University of the United States, to establish which efforts are being made in pursuance of the ideas of Washington expressed in his will; and its possible relations to the scientific bureaus of the government.

He thought that the projectors of the enterprise should avoid any official connection with the government and that the institution should not attempt to duplicate the undergraduate work of existing colleges with which the city is already abundantly supplied. He then outlined a scheme for post-graduate work in connection with the scientific bureaus which he believed practicable and which would occupy a promising field at present unutilized, and which would also involve a minimum of expense, little legislation and no costly buildings. The paper as a whole will appear in the *American Naturalist*.

The second paper, on 'Two Remarkable Semi-diurnal Periods,' was by Professor F. H. Bigelow, of the United States Weather Bureau. An account was given of the three components of the diurnal barometric wave, their distribution and variations in different latitudes, and of



the theories which have been advanced to account for them, with the difficulties which are encountered by them. The variations in the barometric pressure as given by the observations were redistributed relatively to the magnetic poles, the components taken, and compared with the deflecting magnetic forces which cause the daily variation of the needle. It was shown that both systems have a belt of transition near latitude  $60^\circ$ , and a displacement of phase by six hours in the polar regions. Other similar features were indicated, suggesting some mutual dependence between these systems.

A second comparison of these deflecting forces with the diurnal components of wind velocities in middle latitudes exhibited a remarkable agreement in their directions and their turning points. Some statement was made regarding the causes of this phenomenon.

E. D. PRESTON,  
*Secretary.*

BOSTON SOCIETY OF NATURAL HISTORY.

THE Society met November 16th, with eighty-five persons present.

Professor W. Z. Ripley spoke of the racial characteristics of the Jews. The Jews and the Gypsies, alone of European races, preserve their individuality without territory. The numbers, distribution and origin of the European Jews were given in detail; in Europe they are widely and unevenly scattered; probably one half are to be found in Poland and southwestern Russia. For America, though official data are wanting, there are probably one million. The small size of the Jews is marked and is due to hostile legislation, starvation, oppression and environment. The Jews are essentially a town people, and town life tends to depress stature. The inheritance of their short stature is still questioned. Their chest development is small, but in spite of physical degeneracy statistics show that the Jews live twice as long as Christians. The head variation of European races was noted; in the Jews the head form is not persistent and does not indicate purity. The facial characteristics, form of nose, color of hair and eyes of the Jews were described, and the geographical distribution of the race in Europe, their average stature in European countries

and the types of head form were illustrated by lantern views.

SAMUEL HENSHAW,  
*Secretary.*

NEW YORK ACADEMY OF SCIENCES—SECTION OF  
ASTRONOMY AND PHYSICS.

AT the regular monthly meeting of the Section of Astronomy and Physics, held December 5, 1898, Mr. Wallace Goold Levison presented a paper on 'A Classification of the Phosphorescent and Fluorescent Substances,' in which he grouped under the former head all those that give out shorter radiations than they receive, while under the latter he placed those that give out longer radiations than they receive. Each heading was then amplified by sub-headings referring to the manner or circumstances in which a substance phosphoresces or fluoresces.

For instance :

Phosphorescent	{	Thermo-	Heated or cooled.
		Electro-	{ Statically electrified. Exposed to X-rays.
	{	Lumino-	
		Tribo-	{ Rubbed. Compressed. Hammered.
		etc.	

In the same way the fluorescent substances were subdivided.

Mr. Levison showed his system by means of lantern slides of tables or charts on which the substances were arranged as above. He exhibited a large number of slides, and received the congratulations of the members present for the painstaking labor that he had spent upon the subject, as well as for the logical arrangement of the same.

R. GORDON,  
*Secretary of Section.*

NEW BOOKS.

*Studien über Säugethiere.* MAX WEBER. Jena, Gustav Fischer. 1898. 2d Part. Pp. v+152. 12 Marks.

*Physical Geography.* WILLIAM MORRIS DAVIS, assisted by WILLIAM HENRY SNYDER. Boston and London, Ginn & Co. 1898. Pp. xvii+428.

*Degeneracy: Its Causes, Signs and Results.* EUGENE S. TALBOT. New York, Charles Scribner's Sons; London, Walter Scott, Ltd. 1898. Pp. xvi+372. \$1.50.

107530

# SCIENCE

NEW SERIES.  
VOL. VIII. No. 183.

FRIDAY, JULY 1, 1898.

SINGLE COPIES, 15 CTS.  
ANNUAL SUBSCRIPTION, \$5.00.



## GENERAL ELECTRIC CO.'S FLUOROSCOPES

Platino-cyanide of Barium, or Tungstate of Calcium Screens.

**NEW X-RAY TUBE** WITH AUTOMATIC  
VACUUM REGULATOR.  
SIMPLE. EFFICIENT. LONG-LIVED.

**ROENTGEN RAY APPARATUS** of all kinds.  
Catalogue No. 9050.

**Candelabra, Miniature and Decorative Lamps.**  
Catalogue No. 9044.

**Edison Decorative and Miniature Lamp Department,**  
(GENERAL ELECTRIC COMPANY.)  
**HARRISON, N. J.**



WE HAVE JUST ISSUED

## A NEW SHELL CATALOGUE AND PRICE LISTS OF MOLLUSCA

Enlarged to 170 pages. Illustrations Increased to over 200. Contains much Valuable Descriptive Matter. Indispensable to Collectors.

Price, 40 cents, postpaid.

**WARD'S NATURAL SCIENCE ESTABLISHMENT, ROCHESTER, N. Y.**

**MAX KOHL, Chemnitz, Germany,**

FIRST EUROPEAN MAKER OF

## Physical and Electrical Instruments

Special Manufacturer of Roentgen X-Ray Outfits.  
Apparatus for Experiments with Currents of High Frequency and Tension.  
Apparatus for the Experiments according to Hertz.  
Apparatus for Marconi's Wireless Telegraphy.

Price List No. 10 of Physical Instruments; nearly 400 pages and more than 1300 engravings (in German, English and French). Special List of X-Ray Apparatus containing numerous testimonials as well as estimates for complete outfits, explicit directions for use, etc., in English language.

REFERENCES FROM LEADING EXPERTS.

Representative: Messrs. EIMER & AMEND, 205-211 Third Avenue, New York.

JUST ISSUED.

**CRELLE, Calculating Tables.**

First English edition giving products of every two numbers from 1 to 1000.

Folio, cloth bound, . . . . . \$5.00

LEMCKE &amp; BUECHNER,

812 Broadway, New York.

SIXTH EDITION.

**THE MICROSCOPE AND MICROSCOPICAL METHODS.**

By SIMON HENRY GAGE, Professor of Microscopy, Histology and Embryology in Cornell University and the New York State Veterinary College, Ithaca, N. Y., U.S.A. Sixth edition, rewritten, greatly enlarged, and illustrated by 165 figures in the text. Price, \$1.50, postpaid.

COMSTOCK PUBLISHING CO., Ithaca, N. Y.

**NEW CATALOGUE.**

We have recently issued a new edition, revised and enlarged to 64 pages, of our catalogue of

**Books on Chemistry, Chemical Technology and Physics.**

It is arranged by subjects, and includes all the standard books in Chemical and Physical Science, as well as the recent literature up to date.

A copy of this Catalogue will be sent free by mail to any address.

**D. Van Nostrand Company,**

Publishers and Importers of Scientific Books,

27 Murray St. and 27 Warren St., New York.

# Delicious Drink

**Horsford's Acid Phosphate**

with water and sugar only, makes a delicious, healthful and invigorating drink.

Allays the thirst, aids digestion, and relieves the lassitude so common in midsummer.

Dr. M. H. Henry, New York, says: "When completely tired out by prolonged wakefulness and overwork, it is of the greatest value to me. As a beverage it possesses charms beyond anything I know of in the form of medicine."

Descriptive pamphlet free on application to  
Rumford Chemical Works, Providence, R. I.  
Beware of Substitutes and Imitations.**Biddle's Bulletin for June**

My business is to act as an intermediary between the manufacturer and purchaser of Scientific Apparatus. In many respects I believe my methods of conducting these relations are unique, and I know that they are successful. My connections are extensive, so that to keep in touch with my customers—to explain periodically what I am doing—I have started the publication of an 8-page monthly. It is sure to be interesting to a large proportion of those who read this ad. Consequently I want you to write now for a sample copy of the June number.

Subscription, 50 cents a year.

Electrical and Scientific Instruments,  
Psychological Apparatus,  
Projection Lanterns, etc.**JAMES G. BIDDLE, Publisher,**  
909 Drexel Building, Philadelphia.**PHYSICAL, CHEMICAL, MICROSCOPICAL AND ELECTRICAL APPARATUS.**Established  
1882.COMPLETE LABORATORY EQUIPMENT OF OUR OWN MANUFACTURE.  
X-RAY APPARATUS AND CROOKE'S TUBES A SPECIALTY.Incorporated  
1894.Catalogue Free to School  
Officials and Science Teachers.**ZIEGLER ELECTRIC CO.,**

141 Franklin St.,

BOSTON, MASS.

"Duty Free" Importations from  
Foreign Manufacturers.**MINERALS.**EXTRA FINE CABINET SPECIMENS.  
RARE SPECIES. LOOSE CRYSTALS.  
CHEAP EDUCATIONAL SPECIMENS.  
SYSTEMATIC COLLECTIONS.  
BLOWPIPE MINERALS BY THE POUND.

Our Stock greatly enriched by Mr. English's Recent Tour of Europe. Write for full particulars, and for free Price Lists and Bulletins. 124 pp. Catalogue (87 cuts) describing every species, 25c. in paper, 50c. in cloth.

**GEO. L. ENGLISH & CO., Mineralogists, 64 E. 12th St., New York.**



# SCIENCE

NEW SERIES.  
VOL. VIII. No. 184.

FRIDAY, JULY 8, 1898.

SINGLE COPIES, 15 CTS.  
ANNUAL SUBSCRIPTION, \$5.00

## NEW PUBLICATIONS

OF

# QUEEN & CO., INC.

- Manual of Engineering Instruments, their use and adjustment. 186 pp.  
Paper, 25 cents; cloth, \$1.00.
- Manual of Practical Draughting. 70 pp. Paper, 25 cents; cloth, 75 cents.
- Catalogue of Engineering Instruments. 162 pp. *Free.*
- Catalogue T. Electrical Test Instruments. 117 pp. *Free.*
- atalogue I-90. Instruments for Electric Light Stations, including  
Ammeters, Voltmeters, Testing Sets, etc. 44 pp. *Free.*
- Catalogue I-20. Physical Laboratory Supplies. 175 pp. *Free.*
- Catalogue of Microscopes and Biological Laboratory Supplies. 160 pp.  
*Free.*
- Circular No. 274. New Physical Apparatus. 16 pp. *Free.*
- Circular No. 364. The Queen Acme Portable Testing Sets. 20 pp.  
*Free.*
- Circular No. 244. Cable Testing Apparatus. 44 pp. *Free.*
- Circular No. 284. Apparatus manufactured by Société Genevoise. 16  
pp. *Free.*

## QUEEN & CO., INC.

OPTICAL AND SCIENTIFIC INSTRUMENT WORKS,

59 Fifth Ave., New York.

1010 Chestnut St., Philadelphia.

JUST ISSUED.

**CRELLE, Calculating Tables.**

First English edition giving products of every two numbers from 1 to 1000.

Folio, cloth bound, . . . . . \$5.00

LEMCKE & BUECHNER,  
812 Broadway, New York.

SIXTH EDITION.

**THE MICROSCOPE AND MICROSCOPICAL METHODS.**

By SIMON HENRY GAGE, Professor of Microscopy, Histology and Embryology in Cornell University and the New York State Veterinary College, Ithaca, N. Y., U. S. A. Sixth edition, rewritten, greatly enlarged, and illustrated by 165 figures in the text. Price, \$1.50, postpaid.

COMSTOCK PUBLISHING CO., Ithaca, N. Y.

**NEW CATALOGUE.**

We have recently issued a new edition, revised and enlarged to 64 pages, of our catalogue of

**Books on Chemistry, Chemical Technology and Physics.**

It is arranged by subjects, and includes all the standard books in Chemical and Physical Science, as well as the recent literature up to date.

A copy of this Catalogue will be sent free by mail to any address.

**D. Van Nostrand Company,**

Publishers and Importers of Scientific Books,

23 Murray St. and 27 Warren St., New York.

# Delicious Drink

**Horsford's Acid Phosphate**

with water and sugar only, makes a delicious, healthful and invigorating drink.

Allays the thirst, aids digestion, and relieves the lassitude so common in midsummer.

Dr. M. H. Henry, New York, says: "When completely tired out by prolonged wakefulness and overwork, it is of the greatest value to me. As a beverage it possesses charms beyond any-think I know of in the form of medicine."

Descriptive pamphlet free on application to  
Rumford Chemical Works, Providence, R. I.  
Beware of Substitutes and Imitations.**MAX KOHL, Chemnitz, Germany,**

FIRST EUROPEAN MAKER OF

**Physical and Electrical Instruments**Special Manufacturer of Roentgen X-Ray Outfits.  
Apparatus for Experiments with Currents of High Frequency and Tension.  
Apparatus for the Experiments according to Hertz.  
Apparatus for Marconi's Wireless Telegraphy.

Price List No. 10 of Physical Instruments; nearly 400 pages and more than 1300 engravings (in German, English and French). Special List of X-Ray Apparatus containing numerous testimonials as well as estimates for complete outfits, explicit directions for use, etc., in English language.

REFERENCES FROM LEADING EXPERTS.

Representative: Messrs. EIMER &amp; AMEND, 205-211 Third Avenue, New York.

**PHYSICAL, CHEMICAL, MICROSCOPICAL AND ELECTRICAL APPARATUS.**Established  
1882.COMPLETE LABORATORY EQUIPMENT OF OUR OWN MANUFACTURE.  
X-RAY APPARATUS AND CROOKE'S TUBES A SPECIALTY.Incorporated  
1894.Catalogue Free to School  
Officials and Science Teachers.**ZIEGLER ELECTRIC CO.,**  
141 Franklin St..

BOSTON, MASS.

"Duty Free" Importations from  
Foreign Manufacturers.**MINERALS.**EXTRA FINE CABINET SPECIMENS.  
RARE SPECIES. LOOSE CRYSTALS.  
CHEAP EDUCATIONAL SPECIMENS.  
SYSTEMATIC COLLECTIONS.  
BLOWPIPE MINERALS BY THE POUND.

Our Stock greatly enriched by Mr. English's Recent Tour of Europe. Write for full particulars, and for free Price Lists and Bulletins. 124 pp. Catalogue (87 cuts) describing every species, 25c. in paper, 50c. in cloth.

**GEO. L. ENGLISH & CO., Mineralogists, 64 E. 12th St., New York.**

# SCIENCE

NEW SERIES.  
VOL. VIII. No. 185.

FRIDAY, JULY 15, 1898.

SINGLE COPIES, 15 CTS.  
ANNUAL SUBSCRIPTION, \$5.00



## GENERAL ELECTRIC CO.'S NEW X-RAY TUBE

WITH AUTOMATIC VACUUM REGULATOR.

Simple. Efficient. Long-lived. Cannot run too high in vacuum.

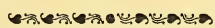

Roentgen Ray Apparatus, catalogue No. 9,050. Miniature, Candelabra, Decorative Lamps, catalogue No. 9,044.



### Edison Decorative and Miniature Lamp Department,

(GENERAL ELECTRIC COMPANY,)

HARRISON, N. J.

## Complete Mineral Catalogue.

each element. Alphabetical index of names. Lists giving the specimen values of minerals, etc., etc. For teachers, students, collectors, mining experts, chemists, and others. *Postpaid; Paper, 25 cents; Cloth, 50 cents; Calf, interleaved, \$1.00.*

186 pages, 40 splendid engravings. Contains a table giving name, composition and form of all known minerals, with a supplement bringing the work up to date. Metallic classification showing what minerals contain collectors, mining experts, chemists, and others. *Postpaid; Paper, 25 cents; Cloth, 50 cents; Calf, interleaved, \$1.00.*

DR. A. E. FOOTE, 1317 Arch Street, Philadelphia, Pa., U. S. A.

*Established 1876*

COLLECTIONS OF MINERALS FOR STUDY OR REFERENCE.

CABINET SPECIMENS.

GEMS.

### MAX KOHL, Chemnitz, Germany,

FIRST EUROPEAN MAKER OF

## Physical and Electrical Instruments

Special Manufacturer of Roentgen X-Ray Outfits.  
Apparatus for Experiments with Currents of High Frequency and Tension.  
Apparatus for the Experiments according to Hertz.  
Apparatus for Marconi's Wireless Telegraphy.

Price List No. 10 of Physical Instruments; nearly 400 pages and more than 1300 engravings (in German, English and French). Special List of X-Ray Apparatus containing numerous testimonials as well as estimates for complete outfits, explicit directions for use, etc., in English language.

REFERENCES FROM LEADING EXPERTS.

Representative: Messrs. EIMER & AMEND, 205-211 Third Avenue, New York.



JUST ISSUED.

**CRELLE, Calculating Tables.**

First English edition giving products of every two numbers from 1 to 1000.

Folio, cloth bound, . . . . . \$5.00

LEMCKE &amp; BUECHNER,

812 Broadway, New York.

SIXTH EDITION.

**THE MICROSCOPE AND MICROSCOPICAL METHODS.**

By SIMON HENRY GAGE, Professor of Microscopy, Histology and Embryology in Cornell University and the New York State Veterinary College, Ithaca, N. Y., U. S. A.  
Sixth edition, rewritten, greatly enlarged, and illustrated by 165 figures in the text. Price, \$1.50, postpaid.

COMSTOCK PUBLISHING CO., Ithaca, N. Y.

**NEW CATALOGUE.**

We have recently issued a new edition, revised and enlarged to 64 pages, of our catalogue of

**Books on Chemistry, Chemical Technology and Physics.**

It is arranged by subjects, and includes all the standard books in Chemical and Physical Science, as well as the recent literature up to date.

A copy of this Catalogue will be sent free by mail to any address.

**D. Van Nostrand Company,**

Publishers and Importers of Scientific Books,

23 Murray St. and 27 Warren St., New York.

**Delicious Drink****Horsford's Acid Phosphate**

with water and sugar only, makes a delicious, healthful and invigorating drink.

Allays the thirst, aids digestion, and relieves the lassitude so common in midsummer.

Dr. M. H. Henry, New York, says: "When completely tired out by prolonged wakefulness and overwork, it is of the greatest value to me. As a beverage it possesses charms beyond anything I know of in the form of medicine."

Descriptive pamphlet free on application to  
Rumford Chemical Works, Providence, R. I.  
Beware of Substitutes and Imitations.

**Biddle's Bulletin for June**

My business is to act as an intermediary between the manufacturer and purchaser of Scientific Apparatus. In many respects I believe my methods of conducting these relations are unique, and I know that they are successful. My connections are extensive, so that to keep in touch with my customers—to explain periodically what I am doing—I have started the publication of an 8-page monthly. It is sure to be interesting to a large proportion of those who read this ad. Consequently I want you to write now for a sample copy of the June number.

Subscription, 50 cents a year.

Electrical and Scientific Instruments,  
Psychological Apparatus,  
Projection Lanterns, etc.

**JAMES G. BIDDLE, Publisher,**  
909 Drexel Building, Philadelphia.

**PHYSICAL, CHEMICAL, MICROSCOPICAL AND ELECTRICAL APPARATUS.**

Established 1882.

COMPLETE LABORATORY EQUIPMENT OF OUR OWN MANUFACTURE.  
X-RAY APPARATUS AND CROOKE'S TUBES A SPECIALTY.

Incorporated 1894.

Catalogue Free to School  
Officials and Science Teachers.

**ZIEGLER ELECTRIC CO.,**  
141 Franklin St., BOSTON, MASS.

"Duty Free" Importations from  
Foreign Manufacturers.

**MINERALS.**

EXTRA FINE CABINET SPECIMENS.  
RARE SPECIES. LOOSE CRYSTALS.  
CHEAP EDUCATIONAL SPECIMENS.  
SYSTEMATIC COLLECTIONS.  
BLOWPIPE MINERALS BY THE POUND.

Our Stock greatly enriched by Mr. English's Recent Tour of Europe. Write for full particulars, and for free Price Lists and Bulletins. 124 pp. Catalogue (87 cuts) describing every species, 25c. in paper, 50c. in cloth.

**GEO. L. ENGLISH & CO., Mineralogists, 64 E. 12th St., New York.**

161470

# SCIENCE

NEW SERIES.  
VOL. VIII. No. 186.

FRIDAY, JULY 22, 1898.

SINGLE COPIES, 15 CTS.  
ANNUAL SUBSCRIPTION, \$5.00

## NEW GRAND MODEL.

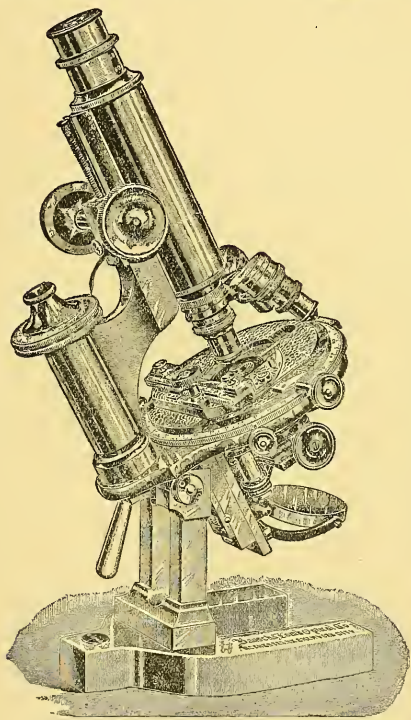

**DDS8 Continental Microscope.**

Adapted especially for the more difficult Biological Work and for Photo-Micrography. Complete 264-page Catalogue and Supplement of Microscopes, Accessories and Laboratory Supplies mailed free.

### **BAUSCH & LOMB OPTICAL CO.**

CHICAGO:  
State and Washington Streets.

ROCHESTER, N. Y.

NEW YORK CITY:  
Broadway and 25th Street.

**The Microscope and Microscopical Methods***Sixth Edition. Fully Illustrated.*

By SIMON HENRY GAGE, of Cornell University.

This book is a product of the laboratory and is designed for actual laboratory use. It deals with the modern microscope and its accessories, microscopical methods, including photo-micrography, etc., and has in view the especial needs of students, teachers and professional men. Postpaid, \$1.50  
COMSTOCK PUBLISHING CO., Ithaca, N. Y.

JUST ISSUED.

**CRELLE, Calculating Tables.**

First English edition giving products of every two numbers from 1 to 1000.

Folio, cloth bound, . . . . . \$5.00

LEMCKE &amp; BUECHNER,

812 Broadway, New York.

**NEW CATALOGUE.**

We have recently issued a new edition, revised and enlarged to 61 pages, of our catalogue of

**Books on Chemistry, Chemical Technology and Physics.**

It is arranged by subjects, and includes all the standard books in Chemical and Physical Science, as well as the recent literature up to date.

A copy of this Catalogue will be sent free by mail to any address.

**D. Van Nostrand Company,**

Publishers and Importers of Scientific Books,

23 Murray St. and 27 Warren St., New York.

**Delicious Drink****Horsford's Acid Phosphate**

with water and sugar only, makes a delicious, healthful and invigorating drink.

Allays the thirst, aids digestion, and relieves the lassitude so common in midsummer.

Dr. M. H. Henry, New York, says: "When completely tired out by prolonged wakefulness and overwork, it is of the greatest value to me. As a beverage it possesses charms beyond anything I know of in the form of medicine."

Descriptive pamphlet free on application to

Rumford Chemical Works, Providence, R. I.

Beware of Substitutes and Imitations.

**MAX KOHL, Chemnitz, Germany,**

FIRST EUROPEAN MAKER OF

**Physical and Electrical Instruments**

Special Manufacturer of Roentgen X-Ray Outfits.

Apparatus for Experiments with Currents of High Frequency and Tension.

Apparatus for the Experiments according to Hertz.

Apparatus for Marconi's Wireless Telegraphy.

Price List No. 10 of Physical Instruments; nearly 400 pages and more than 1300 engravings (in German, English and French). Special List of X-Ray Apparatus containing numerous testimonials as well as estimates for complete outfits, explicit directions for use, etc., in English language.

REFERENCES FROM LEADING EXPERTS.

Representative: Messrs. EIMER &amp; AMEND, 205-211 Third Avenue, New York.

**PHYSICAL, CHEMICAL, MICROSCOPICAL AND ELECTRICAL APPARATUS.**Established  
1882.

COMPLETE LABORATORY EQUIPMENT OF OUR OWN MANUFACTURE.

Incorporated  
1894.

X-RAY APPARATUS AND CROOKE'S TUBES A SPECIALTY.

Catalogue Free to School  
Officials and Science Teachers.**ZIEGLER ELECTRIC CO.,**

141 Franklin St..

**BOSTON, MASS.**"Duty Free" Importations from  
Foreign Manufacturers.**MINERALS.**

EXTRA FINE CABINET SPECIMENS.  
RARE SPECIES. LOOSE CRYSTALS.  
CHEAP EDUCATIONAL SPECIMENS.  
SYSTEMATIC COLLECTIONS.  
BLOWPIPE MINERALS BY THE POUND.

Our Stock greatly enriched by Mr. English's Recent Tour of Europe. Write for full particulars, and for free Price Lists and Bulletins. 124 pp. Catalogue (87 cuts) describing every species, 25c. in paper, 50c. in cloth.

**GEO. L. ENGLISH & CO., Mineralogists, 64 E. 12th St., New York.**



# SCIENCE

NEW SERIES.  
VOL. VIII. No. 187.

FRIDAY, JULY 29, 1898.

SINGLE COPIES, 15 CTS.  
ANNUAL SUBSCRIPTION, \$5.00

## THE MACMILLAN COMPANY'S NEW OR FORTHCOMING BOOKS FOR THE SCIENTIST

### ON NATURAL SCIENCE

JUST READY.

#### The Nature and Development of Animal Intelligence

By Wesley Mills, M.D., D.V.S., F.R.S.C.

*Professor of Physiology in McGill University, Montreal*

The subject is approached from the point of view of comparative psychology.

*Author of "Animal Physiology,"  
"Comparative Physiology," "The  
Dog in Health and Disease."*

**Cloth, 8vo. Price, \$2.00.**

There are chapters on hibernation and allied states from the psychological standpoint, also on the physical correlation to psychic development.

### ON MATHEMATICS

IN PREPARATION.

#### Infinitesimal Analysis. By Wm. B. Smith

The volume treats rather fully and in a modern spirit the Elementary Theory and Applications of the Calculus, so as to meet the wants of undergraduates in general, while fitting and stimulating the few to pass on into differential Equations and the Theory of Functions. More than usual attention has been given to Hyperbolic Functions, Maxima and Minima, Operators, Tortuous Curves, Partial Derivatives, Multiple Integration, Jacobians, Gamma Functions, etc. The author will be remembered as having been for some years Professor of Mathematics in the University of Missouri and at Tulane University of New Orleans. A few years ago he prepared for the use of students in his classes a work of which another teacher of mathematics, at that time in one of the New York State Normal Schools, wrote,

"Its chief merit is that it gives not only knowledge, but the significance of knowledge, hence its glow and inspiration."

—*Missouri School Journal.*

The aim in the new volume is to enable the student of the Calculus to approach the subject in a modern spirit and to acquire all the necessary equipment for the study of the higher Theory.

IN PREPARATION.

#### Elementary Theory of Functions

By James Harkness and Frank Morley

The authors are already known as having published "A Treatise on the Theory of Functions" for advanced students who have had considerable preliminary training in Calculus and other branches of theoretical mathematics.

BY THE SAME AUTHORS.

#### A Treatise on The Theory of Functions

**Cloth, 8vo, \$5.00 net.**

The present work is intended for those who wish to acquire such a knowledge of the subject as is necessary for the pursuit of the ordinary engineering courses.

*Send for a list of the mathematical and scientific text-books published by*

**THE MACMILLAN COMPANY, 66 Fifth Avenue, New York City**

**The Microscope and Microscopical Methods***Sixth Edition. Fully Illustrated.*By **SIMON HENRY GAGE**, of Cornell University.

This book is a product of the laboratory and is designed for actual laboratory use. It deals with the modern microscope and its accessories, microscopical methods, including photo-micrography, etc., and has in view the special needs of students, teachers and professional men. Postpaid, \$1.50  
**COMSTOCK PUBLISHING CO.**, Ithaca, N. Y.

*JUST ISSUED.***CRELLE, Calculating Tables.**

First English edition giving products of every two numbers from 1 to 1000.

Folio, cloth bound, . . . . . \$5.00

**LEMCKE & BUECHNER,**

812 Broadway, New York.

**NEW CATALOGUE.**

We have recently issued a new edition, revised and enlarged to 64 pages, of our catalogue of

**Books on Chemistry, Chemical Technology and Physics.**

It is arranged by subjects, and includes all the standard books in Chemical and Physical Science, as well as the recent literature up to date.

A copy of this Catalogue will be sent free by mail to any address.

**D. Van Nostrand Company,**

Publishers and Importers of Scientific Books,

23 Murray St. and 27 Warren St., New York.

# Delicious Drink

**Horsford's Acid Phosphate**

with water and sugar only, makes a delicious, healthful and invigorating drink.

Allays the thirst, aids digestion, and relieves the lassitude so common in midsummer.

Dr. M. H. Henry, New York, says: "When completely tired out by prolonged wakefulness and overwork, it is of the greatest value to me. As a beverage it possesses charms beyond any-think I know of in the form of medicine."

Descriptive pamphlet free on application to

**Rumford Chemical Works, Providence, R. I.**

Beware of Substitutes and Imitations.

**MAX KOHL, Chemnitz, Germany,**

FIRST EUROPEAN MAKER OF

## Physical and Electrical Instruments

Special Manufacturer of Roentgen X-Ray Outfits.

Apparatus for Experiments with Currents of High Frequency and Tension.

Apparatus for the Experiments according to Hertz.

Apparatus for Marconi's Wireless Telegraphy.

Price List No. 10 of Physical Instruments; nearly 400 pages and more than 1300 engravings (in German, English and French). Special List of X-Ray Apparatus containing numerous testimonials as well as estimates for complete outfits, explicit directions for use, etc., in English language.

REFERENCES FROM LEADING EXPERTS.

Representative: Messrs. **EIMER & AMEND**, 205-211 Third Avenue, New York.

## Complete Mineral Catalogue.

each element. Alphabetical index of names. Lists giving the specimen values of minerals, etc., etc. For teachers, students, collectors, mining experts, chemists, and others. Postpaid; Paper, 25 cents; Cloth, 50 cents; Calf. interleaved, \$1.00.

**DR. A. E. FOOTE**, 1317 Arch Street, Philadelphia, Pa., U. S. A.

Established 1876

COLLECTIONS OF MINERALS FOR STUDY OR REFERENCE.

CABINET SPECIMENS.

GEMS.

## MINERALS.

EXTRA FINE CABINET SPECIMENS.  
 RARE SPECIES. LOOSE CRYSTALS.  
 CHEAP EDUCATIONAL SPECIMENS.  
 SYSTEMATIC COLLECTIONS.  
 BLOWPIPE MINERALS BY THE POUND.

Our Stock greatly enriched by Mr. English's Recent Tour of Europe. Write for full particulars, and for free Price Lists and Bulletins. 124 pp. Catalogue (87 cuts) describing every species, 25c. in paper, 50c. in cloth.

**GEO. L. ENGLISH & CO.**, Mineralogists, 64 E. 12th St., New York.

# SCIENCE

NEW SERIES.  
VOL. VIII. No 188.

FRIDAY, AUGUST 5, 1898.

SINGLE COPIES, 15 CTS.  
ANNUAL SUBSCRIPTION, \$5.00



## GENERAL ELECTRIC Co.'S FLUOROSCOPES

Platino-cyanide of Barium, or Tungstate of Calcium Screens.

**NEW X-RAY TUBE** WITH AUTOMATIC  
VACUUM REGULATOR.  
SIMPLE. EFFICIENT. LONG-LIVED.

**ROENTGEN RAY APPARATUS** of all kinds.

Catalogue No. 9050.

**Candelabra, Miniature and Decorative Lamps.**

Catalogue No. 9044.

**Edison Decorative and Miniature Lamp Department,**

(GENERAL ELECTRIC COMPANY,)

**HARRISON, N. J.**

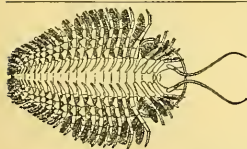

### The BEECHER MODELS of TRILOBITES and BRACHIOPODS

are the only satisfactory means of showing the complete forms of these animals. Illustrated circulars concerning each will be sent on application.

*Ward's Natural Science Establishment,*  
ROCHESTER, N. Y.

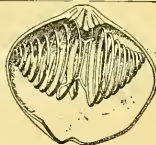

**THIRD VOLUME, COMPLETING THE WORK, JUST READY!**

## AN ILLUSTRATED FLORA

OF THE NORTHERN UNITED STATES AND CANADA,  
VIRGINIA TO KANSAS INCLUDED.

By Professor NATHANIEL L. BRITTON and Hon. ADDISON BROWN,

With the assistance of Specialists in Various Groups. Every known species illustrated, numbering 4162. In three Imperial 8vo volumes of about 620 pages each. The set \$9.00, transportation extra.

Those already having Volumes I. and II. can secure Volume III. for \$3.00, special net; postage 36 cents extra.

Volume I., Ferns to Carpet Weed. Volume II., Portulaca to Gentian. Volume III., Dogbane to Thistle. Volume III. contains a General Key to the Orders and Families, a Glossary, and Latin and English indices to the three volumes, including about 10,000 popular names. The Indices are also supplied separately in a uniform index volume of 84 pages at \$1.00 net, postage 9 cents extra.

"The appearance of this third volume marks the completion of the most important botanical treatise issued in America since the completion of Gray's Manual. Every species is shown in pictures as well as described, and the result is a work which must henceforth be indispensable to students of botany."—*The Congregationalist*.

**CHARLES SCRIBNER'S SONS, 153-157 FIFTH AVENUE, NEW YORK.**



**The Microscope and Microscopical Methods***Sixth Edition. Fully Illustrated.*By **SIMON HENRY GAGE**, of Cornell University.

This book is a product of the laboratory and is designed for actual laboratory use. It deals with the modern microscope and its accessories, microscopical methods, including photo-micrography, etc., and has in view the especial needs of students, teachers and professional men. Postpaid, \$1.50

COMSTOCK PUBLISHING CO., Ithaca, N. Y.

JUST ISSUED.

**CRELLE, Calculating Tables.**

First English edition giving products of every two numbers from 1 to 1000.

Folio, cloth bound, . . . . . \$5.00

LEMCHE &amp; BUECHNER,

812 Broadway, New York.

**NEW CATALOGUE.**

We have recently issued a new edition, revised and enlarged to 64 pages, of our catalogue of

**Books on Chemistry, Chemical Technology and Physics.**

It is arranged by subjects, and includes all the standard books in Chemical and Physical Science, as well as the recent literature up to date.

A copy of this Catalogue will be sent free by mail to any address.

**D. Van Nostrand Company,**

Publishers and Importers of Scientific Books,

23 Murray St. and 27 Warren St., New York.

**Delicious Drink****Horsford's Acid Phosphate**

with water and sugar only, makes a delicious, healthful and invigorating drink.

Allays the thirst, aids digestion, and relieves the lassitude so common in midsummer.

Dr. M. H. Henry, New York, says: "When completely tired out by prolonged wakefulness and overwork, it is of the greatest value to me. As a beverage it possesses charms beyond any-think I know of in the form of medicine."

Descriptive pamphlet free on application to  
Rumford Chemical Works, Providence, R. I.  
Beware of Substitutes and Imitations.

**MAX KOHL, Chemnitz, Germany,**

FIRST EUROPEAN MAKER OF

**Physical and Electrical Instruments**

Special Manufacturer of Roentgen X-Ray Outfits.  
Apparatus for Experiments with Currents of High Frequency and Tension.  
Apparatus for the Experiments according to Hertz.  
Apparatus for Marconi's Wireless Telegraphy.

Price List No. 10 of Physical Instruments; nearly 400 pages and more than 1300 engravings (in German, English and French). Special List of X-Ray Apparatus containing numerous testimonials as well as estimates for complete outfits, explicit directions for use, etc., in English language.

REFERENCES FROM LEADING EXPERTS.

Representative: Messrs. EIMER &amp; AMEND, 205-211 Third Avenue, New York.

**PHYSICAL, CHEMICAL, MICROSCOPICAL AND ELECTRICAL APPARATUS.**Established  
1882.COMPLETE LABORATORY EQUIPMENT OF OUR OWN MANUFACTURE.  
X-RAY APPARATUS AND CROOKE'S TUBES A SPECIALTY.Incorporated  
1894.Catalogue Free to School  
Officials and Science Teachers.**ZIEGLER ELECTRIC CO.,**  
141 Franklin St., BOSTON, MASS."Duty Free" Importations from  
Foreign Manufacturers.**MINERALS.**

EXTRA FINE CABINET SPECIMENS.  
RARE SPECIES. LOOSE CRYSTALS.  
CHEAP EDUCATIONAL SPECIMENS.  
SYSTEMATIC COLLECTIONS.  
BLOWPIPE MINERALS BY THE POUND.

Our Stock greatly enriched by Mr. English's Recent Tour of Europe. Write for full particulars, and for free Price Lists and Bulletins. 124 pp. Catalogue (87 cuts) describing every species, 25c. in paper, 50c. in cloth.

**GEO. L. ENGLISH & CO., Mineralogists, 64 E. 12th St., New York.**

10169

# SCIENCE

NEW SERIES.  
VOL. VIII. No. 189.

FRIDAY, AUGUST 12, 1898.

SINGLE COPIES, 15 CTS.  
ANNUAL SUBSCRIPTION, \$5.00

## New Line of Laboratory Utensils

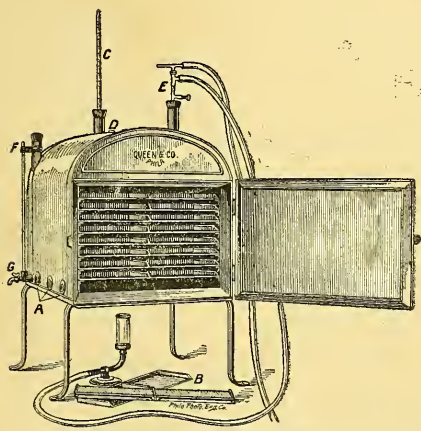

**Laboratory Drying Ovens.**  
(Devised by Prof. W. M. L. Coplin, M.D.)

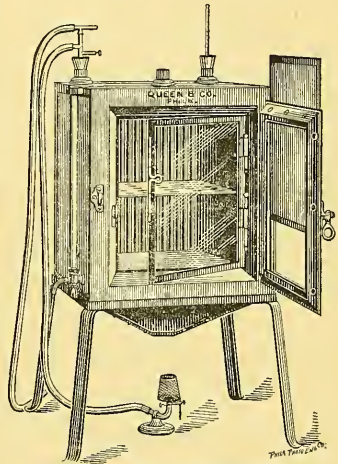

**Medium Laboratory Incubator.**

**Incubators, Sterilizers, Paraffine Baths, Drying Ovens.**

**Special Copper Work Done to Order.**

Send for New Catalogue, B. M., 1898, of Microscopes and Laboratory Supplies.

## QUEEN & CO., INC.,

*...Optical and Scientific Instrument Works...*

New York Branch: 59 Fifth Ave.

**1010 CHESTNUT ST., PHILADELPHIA.**

**The Microscope and Microscopical Methods***Sixth Edition. Fully Illustrated.*By **SIMON HENRY GAGE**, of Cornell University.

This book is a product of the laboratory and is designed for actual laboratory use. It deals with the modern microscope and its accessories, microscopical methods, including photo-micrography, etc., and has in view the especial needs of students, teachers and professional men. Postpaid, \$1.50  
**COMSTOCK PUBLISHING CO., Ithaca, N. Y.**

*JUST ISSUED.***CRELLE, Calculating Tables.**

First English edition giving products of every two numbers from 1 to 1000.

Folio, cloth bound, . . . . . \$5.00

**LEMCKE & BUECHNER,**  
 812 Broadway, New York.

**NEW CATALOGUE.**

We have recently issued a new edition, revised and enlarged to 64 pages, of our catalogue of

**Books on Chemistry, Chemical Technology and Physics.**

It is arranged by subjects, and includes all the standard books in Chemical and Physical Science, as well as the recent literature up to date.

A copy of this Catalogue will be sent free by mail to any address.

**D. Van Nostrand Company,**

Publishers and Importers of Scientific Books,

23 Murray St. and 27 Warren St., New York.

# Delicious Drink

**Horsford's Acid Phosphate**

with water and sugar only, makes a delicious, healthful and invigorating drink.

Allays the thirst, aids digestion, and relieves the lassitude so common in midsummer.

Dr. M. H. Henry, New York, says: "When completely tired out by prolonged wakefulness and overwork, it is of the greatest value to me. As a beverage it possesses charms beyond any-think I know of in the form of medicine."

Descriptive pamphlet free on application to  
**Rumford Chemical Works, Providence, R. I.**  
 Beware of Substitutes and Imitations.

**MAX KOHL, Chemnitz, Germany,**

FIRST EUROPEAN MAKER OF

## Physical and Electrical Instruments

Special Manufacturer of Roentgen X-Ray Outfits.

Apparatus for Experiments with Currents of High Frequency and Tension.

Apparatus for the Experiments according to Hertz.

Apparatus for Marconi's Wireless Telegraphy.

Price List No. 10 of Physical Instruments; nearly 400 pages and more than 1300 engravings (in German, English and French). Special List of X-Ray Apparatus containing numerous testimonials as well as estimates for complete outfits, explicit directions for use, etc., in English language.

☞ REFERENCES FROM LEADING EXPERTS. ☞

Representative: **Messrs. EIMER & AMEND, 205-211 Third Avenue, New York.**

## PHYSICAL, CHEMICAL, MICROSCOPICAL AND ELECTRICAL APPARATUS.

Established  
1882.

COMPLETE LABORATORY EQUIPMENT OF OUR OWN MANUFACTURE.  
 X-RAY APPARATUS AND CROOKE'S TUBES A SPECIALTY.

Incorporated  
1894.

Catalogue Free to School  
 Officials and Science Teachers.

**ZIEGLER ELECTRIC CO.,**  
 141 Franklin St., BOSTON, MASS.

"Duty Free" Importations from  
 Foreign Manufacturers.

## MINERALS.

EXTRA FINE CABINET SPECIMENS.  
 RARE SPECIES. LOOSE CRYSTALS.  
 CHEAP EDUCATIONAL SPECIMENS.  
 SYSTEMATIC COLLECTIONS.  
 BLOWPIPE MINERALS BY THE POUND.

Our Stock greatly enriched by Mr. English's Recent Tour of Europe. Write for full particulars, and for free Price Lists and Bulletins. 124 pp. Catalogue (87 cuts) describing every species, 25c. in paper, 50c. in cloth.

**GEO. L. ENGLISH & CO., Mineralogists, 64 E. 12th St., New York.**



# SCIENCE

NEW SERIES.  
Vol. VIII. No. 190.

FRIDAY, AUGUST 19, 1898.

SINGLE COPIES, 15 CTS.  
ANNUAL SUBSCRIPTION, \$5.00.



## GENERAL ELECTRIC CO.'S NEW X-RAY TUBE

WITH AUTOMATIC VACUUM REGULATOR.

Simple. Efficient. Long-lived. Cannot run too high in vacuum.



Roentgen Ray Apparatus, catalogue No. 9,050. Miniature, Candelabra, Decorative Lamps, catalogue No. 9,044.



### Edison Decorative and Miniature Lamp Department,

(GENERAL ELECTRIC COMPANY,)

HARRISON, N. J.

## Complete Mineral Catalogue.

each element. Alphabetical index of names. Lists giving the specimen values of minerals, etc., etc. For teachers, students, collectors, mining experts, chemists, and others. *Postpaid; Paper, 25 cents; Cloth, 50 cents; Calf, interleaved, \$1.00.*

186 pages, 40 splendid engravings. Contains a table giving name, composition and form of all known minerals, with a supplement bringing the work up to date. Metallic classification showing what minerals contain

DR. A. E. FOOTE, 1317 Arch Street, Philadelphia, Pa, U. S. A.

Established 1876.

COLLECTIONS OF MINERALS FOR STUDY OR REFERENCE.

CABINET SPECIMENS.

GEMS.

### MAX KOHL, Chemnitz, Germany,

FIRST EUROPEAN MAKER OF

## Physical and Electrical Instruments

Special Manufacturer of Roentgen X-Ray Outfits.

Apparatus for Experiments with Currents of High Frequency and Tension.

Apparatus for the Experiments according to Hertz.

Apparatus for Marconi's Wireless Telegraphy.

Price List No. 10 of Physical Instruments; nearly 400 pages and more than 1300 engravings (in German, English and French). Special List of X-Ray Apparatus containing numerous testimonials as well as estimates for complete outfits, explicit directions for use, etc., in English language.

REFERENCES FROM LEADING EXPERTS.

Representative: Messrs. EIMER & AMEND, 205-211 Third Avenue, New York.

**The Microscope and Microscopical Methods***Sixth Edition. Fully Illustrated.*

By SIMON HENRY GAGE, of Cornell University.

This book is a product of the laboratory and is designed for actual laboratory use. It deals with the modern microscope and its accessories, microscopical methods, including photo-micrography, etc., and has in view the especial needs of students, teachers and professional men. Postpaid, \$1.50

COMSTOCK PUBLISHING CO., Ithaca, N. Y.

JUST ISSUED.

**CRELLE, Calculating Tables.**

First English edition giving products of every two numbers from 1 to 1000.

Folio, cloth bound, . . . . . \$3.00

LEMCKE &amp; BUECHNER,

812 Broadway, New York.

**NEW CATALOGUE.**

We have recently issued a new edition, revised and enlarged to 64 pages, of our catalogue of

**Books on Chemistry, Chemical Technology and Physics.**

It is arranged by subjects, and includes all the standard books in Chemical and Physical Science, as well as the recent literature up to date.

A copy of this Catalogue will be sent free by mail to any address.

**D. Van Nostrand Company,**

Publishers and Importers of Scientific Books,

23 Murray St. and 27 Warren St., New York.

# Delicious Drink

**Horsford's Acid Phosphate**

with water and sugar only, makes a delicious, healthful and invigorating drink.

Allays the thirst, aids digestion, and relieves the lassitude so common in midsummer.

Dr. M. H. Henry, New York, says: "When completely tired out by prolonged wakefulness and overwork, it is of the greatest value to me. As a beverage it possesses charms beyond anything I know of in the form of medicine."

Descriptive pamphlet free on application to

Rumford Chemical Works, Providence, R. I.

Beware of Substitutes and Imitations.

## Biddle's Bulletin

My business is to act as an intermediary between the manufacturer and purchaser of Scientific Apparatus. In many respects I believe my methods of conducting these relations are unique, and I know that they are successful. My connections are extensive, so that to keep in touch with my customers—to explain periodically what I am doing—I have started the publication of an 8-page monthly. It is sure to be interesting to a large proportion of those who read this ad. Consequently I want you to write now for a sample copy.

Subscription, 50 cents a year.

Electrical and Scientific Instruments,  
Psychological Apparatus,  
Projection Lanterns, etc.

JAMES G. BIDDLE, Publisher,

909 Drexel Building, Philadelphia.

## WM. GAERTNER & CO., Scientific Instrument Works

152-156 Fifty-Sixth St., CHICAGO.

Manufacturers of ASTRONOMICAL AND PHYSICAL APPARATUS of modern design and high-grade workmanship. SPECIALTIES: Equatorial Telescopes, Micrometers, Spectroscopes, Linear and Circular Dividing Engines, Comparators, Michelson Interferometers, Bolometers, etc., etc. General Laboratory Apparatus. Universal Laboratory Supports.

*References from Leading Scientists. Catalogue on Application.*

## MINERALS.

EXTRA FINE CABINET SPECIMENS.  
RARE SPECIES. LOOSE CRYSTALS.  
CHEAP EDUCATIONAL SPECIMENS.  
SYSTEMATIC COLLECTIONS.  
BLOWPIPE MINERALS BY THE POUND.

Our Stock greatly enriched by Mr. English's Recent Tour of Europe. Write for full particulars, and for free Price Lists and Bulletins. 124 pp. Catalogue (87 cuts) describing every species, 25c. in paper, 50c. in cloth.

**GEO. L. ENGLISH & CO., Mineralogists, 64 E. 12th St., New York.**

# SCIENCE

NEW SERIES.  
VOL. VIII. No. 191.

FRIDAY, AUGUST 26, 1898.

SINGLE COPIES, 15 CTS.  
ANNUAL SUBSCRIPTION, \$5.00

## NEW GRAND MODEL.

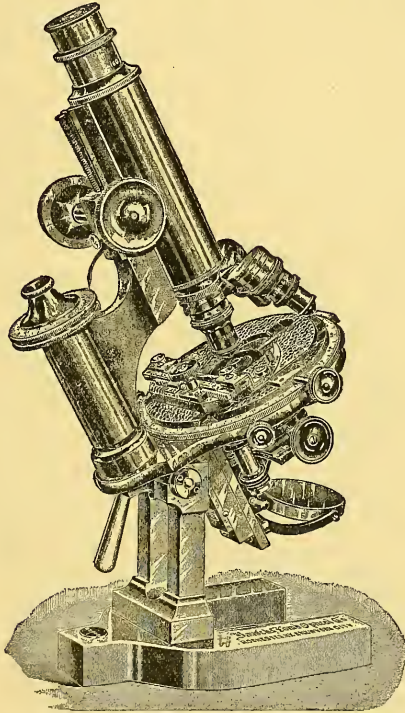

**DDS8 Continental Microscope.**

Adapted especially for the more difficult Biological Work and for Photo-Micrography. Complete 264-page Catalogue and Supplement of Microscopes, Accessories and Laboratory Supplies mailed free.

**BAUSCH & LOMB OPTICAL CO.**

CHICAGO:  
State and Washington Streets.

ROCHESTER, N. Y.

NEW YORK CITY:  
Broadway and 25th Street.



**The Microscope and Microscopical Methods***Sixth Edition. Fully Illustrated.*By **SIMON HENRY GAGE**, of Cornell University.

This book is a product of the laboratory and is designed for actual laboratory use. It deals with the modern microscope and its accessories, microscopical methods, including photo-micrography, etc., and has in view the especial needs of students, teachers and professional men. Postpaid, \$1.50

COMSTOCK PUBLISHING CO., Ithaca, N. Y.

JUST ISSUED.

**CRELLE, Calculating Tables.**

First English edition giving products of every two numbers from 1 to 1000.

Folio, cloth bound, . . . . . \$5.00

**LEMCKE & BUECHNER,**

812 Broadway, New York.

**NEW CATALOGUE.**

We have recently issued a new edition, revised and enlarged to 64 pages, of our catalogue of

**Books on Chemistry, Chemical Technology and Physics.**

It is arranged by subjects, and includes all the standard books in Chemical and Physical Science, as well as the recent literature up to date.

A copy of this Catalogue will be sent free by mail to any address.

**D. Van Nostrand Company,**

Publishers and Importers of Scientific Books,

23 Murray St. and 27 Warren St., New York.

# Delicious Drink

**Horsford's Acid Phosphate ]**

with water and sugar only, makes a delicious, healthful and invigorating drink.

Allays the thirst, aids digestion, and relieves the lassitude so common in midsummer.

Dr. M. H. Henry, New York, says: "When completely tired out by prolonged wakefulness and overwork, it is of the greatest value to me. As a beverage it possesses charms beyond any think I know of in the form of medicine."

Descriptive pamphlet free on application to  
Rumford Chemical Works, Providence, R. I.  
Beware of Substitutes and Imitations.

**WM. GAERTNER & CO., Scientific Instrument Works****152-156 Fifty-Sixth St., CHICAGO.**

Manufacturers of **ASTRONOMICAL AND PHYSICAL APPARATUS** of modern design and high-grade workmanship. **SPECIALTIES:** Equatorial Telescopes, Micrometers, Spectroscopes, Linear and Circular Dividing Engines, Comparators, Michelson Interferometers, Bolometers, etc., etc. **General Laboratory Apparatus.** Universal Laboratory Supports.

*References from Leading Scientists. Catalogue on Application.***MAX KOHL, Chemnitz, Germany,****FIRST EUROPEAN MAKER OF****Physical and Electrical Instruments**

Special Manufacturer of Roentgen X-Ray Outfits.

Apparatus for Experiments with Currents of High Frequency and Tension.

Apparatus for the Experiments according to Hertz.

Apparatus for Marconi's Wireless Telegraphy.

Price List No. 10 of Physical Instruments; nearly 400 pages and more than 1300 engravings (in German, English and French). Special List of X-Ray Apparatus containing numerous testimonials as well as estimates for complete outfits, explicit directions for use, etc., in English language.

— REFERENCES FROM LEADING EXPERTS. —

Representative: Messrs. EIMER &amp; AMEND, 205-211 Third Avenue, New York.

**PHYSICAL, CHEMICAL, MICROSCOPICAL AND ELECTRICAL APPARATUS.**Established  
1882.**COMPLETE LABORATORY EQUIPMENT OF OUR OWN MANUFACTURE.**  
**X-RAY APPARATUS AND CROOKE'S TUBES A SPECIALTY.**Incorporated  
1894.Catalogue Free to School  
Officials and Science Teachers.**ZIEGLER ELECTRIC CO.,**  
141 Franklin St., BOSTON, MASS."Duty Free" Importations from  
Foreign Manufacturers.

# SCIENCE

NEW SERIES.  
VOL. VIII. No. 192.

FRIDAY, SEPTEMBER 2, 1898.

SINGLE COPIES, 15 CTS.  
ANNUAL SUBSCRIPTION, \$5.00



## GENERAL ELECTRIC CO.'S FLUOROSCOPES

Platino-cyanide of Barium, or Tungstate of Calcium Screens.

**NEW X-RAY TUBE** WITH AUTOMATIC  
VACUUM REGULATOR.  
*SIMPLE. EFFICIENT. LONG-LIVED.*

**ROENTGEN RAY APPARATUS** of all kinds.

Catalogue No. 9050.

**Candelabra, Miniature and Decorative Lamps.**

Catalogue No. 9044.

**Edison Decorative and Miniature Lamp Department,**

(GENERAL ELECTRIC COMPANY,)

**HARRISON, N. J.**



## MINERALS.

**SPHERULITES** from Colorado at from 30c. to \$2 for a specimen 4 inches in diameter, sections 50c. and \$1.50. **TRIDYMIT** from New Mexico, \$1.25. New lot of fine **CRYSTALLIZED COPPERS** from Lake Superior, 75c. to \$30. **CALCITE** containing native copper, 10c. to \$1.50. **MASSIVE DATOLITE**, Lake Superior, \$1 to \$2. **NATIVE SILVER ON COPPER**, Lake Superior, \$1. **ANDESITE TUFF** stained with iron oxides and showing contortions, Colorado, 75c. to \$1. *Write for Circulars.*

**WARD'S NATURAL SCIENCE ESTABLISHMENT, 18 to 28 College Ave., Rochester, N. Y.**

**MAX KOHL, Chemnitz, Germany,**

FIRST EUROPEAN MAKER OF

## Physical and Electrical Instruments

Special Manufacturer of Roentgen X-Ray Outfits.  
Apparatus for Experiments with Currents of High Frequency and Tension.  
Apparatus for the Experiments according to Hertz.  
Apparatus for Marconi's Wireless Telegraphy.

Price List No. 10 of Physical Instruments; nearly 400 pages and more than 1300 engravings (in German, English and French). Special List of X-Ray Apparatus containing numerous testimonials as well as estimates for complete outfits, explicit directions for use, etc., in English language.

— REFERENCES FROM LEADING EXPERTS. —

Representative: Messrs. EIMER & AMEND, 205-211 Third Avenue, New York.

## The Microscope and Microscopical Methods

*Sixth Edition. Fully Illustrated.*

By SIMON HENRY GAGE, of Cornell University.

This book is a product of the laboratory and is designed for actual laboratory use. It deals with the modern microscope and its accessories, microscopical methods, including photo-micrography, etc., and has in view the special needs of students, teachers and professional men. Postpaid, \$1.50  
COMSTOCK PUBLISHING CO., Ithaca, N. Y.

JUST ISSUED.

## CRELLE, Calculating Tables.

First English edition giving products of every two numbers from 1 to 1000.

Folio, cloth bound, . . . . . \$5.00

LEMCKE & BUECHNER,  
812 Broadway, New York.

### NEW CATALOGUE.

We have recently issued a new edition, revised and enlarged to 64 pages, of our catalogue of

### Books on Chemistry, Chemical Technology and Physics.

It is arranged by subjects, and includes all the standard books in Chemical and Physical Science, as well as the recent literature up to date.

A copy of this Catalogue will be sent free by mail to any address.

## D. Van Nostrand Company,

Publishers and Importers of Scientific Books,

23 Murray St. and 27 Warren St., New York.

# Delicious Drink

## Horsford's Acid Phosphate

with water and sugar only, makes a delicious, healthful and invigorating drink.

Allays the thirst, aids digestion, and relieves the lassitude so common in midsummer.

Dr. M. H. Henry, New York, says: "When completely tired out by prolonged wakefulness and overwork, it is of the greatest value to me. As a beverage it possesses charms beyond anything I know of in the form of medicine."

Descriptive pamphlet free on application to  
Rumford Chemical Works, Providence, R. I.

Beware of Substitutes and Imitations.

## WM. GAERTNER & CO., Scientific Instrument Works

152-156 Fifty-Sixth St., CHICAGO.

Manufacturers of ASTRONOMICAL AND PHYSICAL APPARATUS of modern design and high-grade workmanship. SPECIALTIES: Equatorial Telescopes, Micrometers, Spectroscopes, Linear and Circular Dividing Engines, Comparators, Michelson Interferometers, Bolometers, etc., etc. General Laboratory Apparatus. Universal Laboratory Supports.

References from Leading Scientists. Catalogue on Application.

## Complete Mineral Catalogue.

each element. Alphabetical index of names. Lists giving the specimen values of minerals, etc., etc. For teachers, students, collectors, mining experts, chemists, and others. Postpaid; Paper, 25 cents; Cloth, 50 cents; Calf, interleaved, \$1.00.

DR. A. E. FOOTE, 1317 Arch Street, Philadelphia, Pa. U. S. A.

Established 1876.

COLLECTIONS OF MINERALS FOR STUDY OR REFERENCE.

CABINET SPECIMENS.

GEMS.

## PHYSICAL, CHEMICAL, MICROSCOPICAL AND ELECTRICAL APPARATUS.

Established  
1882.

COMPLETE LABORATORY EQUIPMENT OF OUR OWN MANUFACTURE.  
X-RAY APPARATUS AND CROOKE'S TUBES A SPECIALTY.

Incorporated  
1894.

Catalogue Free to School  
Officials and Science Teachers.

ZIEGLER ELECTRIC CO.,

141 Franklin St..

BOSTON, MASS.

"Duly Free" Importations from  
Foreign Manufacturers.

## MINERALS.

EXTRA FINE CABINET SPECIMENS.  
RARE SPECIES. LOOSE CRYSTALS.  
CHEAP EDUCATIONAL SPECIMENS.  
SYSTEMATIC COLLECTIONS.  
BLOWPIPE MINERALS BY THE POUND.

Our Stock greatly enriched by Mr. English's Recent Tour of Europe. Write for full particulars, and for free Price Lists and Bulletins. 124 pp. Catalogue (87 cuts) describing every species, 25c. in paper, 50c. in cloth.

GEO. L. ENGLISH & CO., Mineralogists, 64 E. 12th St., New York.



503.7

# SCIENCE

NEW SERIES.  
VOL. VIII. No. 193.

FRIDAY, SEPTEMBER 9, 1898.

SINGLE COPIES, 15 CTS.  
ANNUAL SUBSCRIPTION, \$5.00

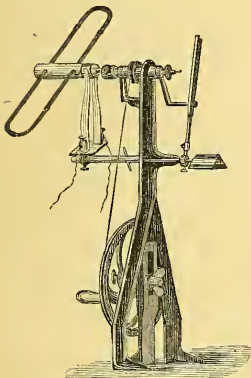

Whirling Table.

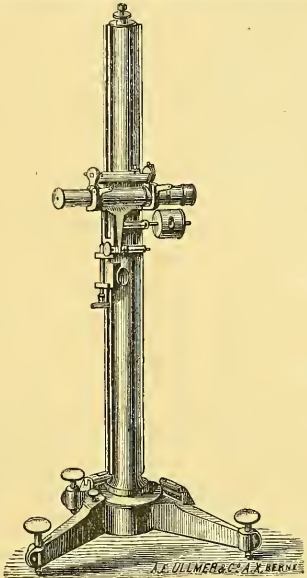

Cathetometer.

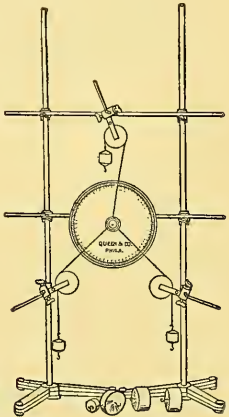

Parallelogram of Forces.

## New Physical Apparatus for Demonstration, Research and Laboratory Practice.

Our new edition of Cat. I., now in press, describes and illustrates the most complete line of Physical Apparatus for both Lecture Room and Laboratory that we have ever published. It includes apparatus for use in Physical Optics and Students' Electrical Measuring heretofore listed separately. It, together with our new Catalogue of Physical Laboratory SUPPLIES, should be in the hands of every teacher of Physics. Write for it.

### QUEEN & CO., INC.,

...Optical and Scientific Instrument Works...

New York Branch: 59 Fifth Ave.

1010 CHESTNUT ST., PHILADELPHIA.

*Absolutely Reliable Always*

# Remington

Standard Typewriter.

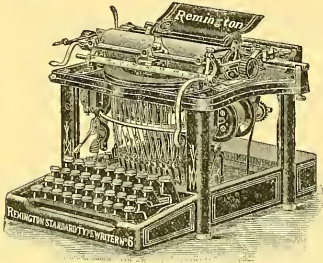

NEW MODELS.

Wyckoff, Seamans & Benedict,  
327 Broadway, New York.

# Delicious Drink

Horsford's Acid Phosphate

with water and sugar only, makes a delicious, healthful and invigorating drink.

Allays the thirst, aids digestion, and relieves the lassitude so common in midsummer.

Dr. M. H. Henry, New York, says: "When completely tired out by prolonged wakefulness and overwork, it is of the greatest value to me. As a beverage it possesses charms beyond anything I know of in the form of medicine."

Descriptive pamphlet free on application to  
Rumford Chemical Works, Providence, R. I.  
Beware of Substitutes and Imitations.

**MAX KOHL, Chemnitz, Germany,**

FIRST EUROPEAN MAKER OF

## Physical and Electrical Instruments

Special Manufacturer of Roentgen X-Ray Outfits.  
Apparatus for Experiments with Currents of High Frequency and Tension.  
Apparatus for the Experiments according to Hertz.  
Apparatus for Marconi's Wireless Telegraphy.

Price List No. 10 of Physical Instruments; nearly 400 pages and more than 1300 engravings (in German, English and French). Special List of X-Ray Apparatus containing numerous testimonials as well as estimates for complete outfits, explicit directions for use, etc., in English language.

REFERENCES FROM LEADING EXPERTS.

Representative: Messrs. EIMER & AMEND, 205-211 Third Avenue, New York.

## PHYSICAL, CHEMICAL, MICROSCOPICAL AND ELECTRICAL APPARATUS.

Established  
1882.

COMPLETE LABORATORY EQUIPMENT OF OUR OWN MANUFACTURE.  
X-RAY APPARATUS AND CROOKE'S TUBES A SPECIALTY.

Incorporated  
1894.

Catalogue **P** Free to School  
Officials and Science Teachers.

**ZIEGLER ELECTRIC CO.,**

141 Franklin St..

BOSTON, MASS.

"Duty Free" Importations from  
Foreign Manufacturers.

## MINERALS.

EXTRA FINE CABINET SPECIMENS.  
RARE SPECIES. LOOSE CRYSTALS.  
CHEAP EDUCATIONAL SPECIMENS.  
SYSTEMATIC COLLECTIONS.  
BLOWPIPE MINERALS BY THE POUND.

Our Stock greatly enriched by Mr. English's Recent Tour of Europe. Write for full particulars, and for free Price Lists and Bulletins. 124 pp. Catalogue (87 cuts) describing every species, 25c. in paper, 50c. in cloth.

**GEO. L. ENGLISH & CO., Mineralogists, 64 E. 12th St., New York.**

# SCIENCE

NEW SERIES.  
VOL. VIII. No. 194.

FRIDAY, SEPTEMBER 16, 1898.

SINGLE COPIES, 15 CTS.  
ANNUAL SUBSCRIPTION, \$5.00.



## GENERAL ELECTRIC CO.'S NEW X-RAY TUBE

WITH AUTOMATIC VACUUM REGULATOR.

Simple. Efficient. Long-lived. Cannot run too high in vacuum.



Roentgen Ray Apparatus, catalogue No. 9,050. Miniature, Candelabra, Decorative Lamps, catalogue No. 9,044.



### Edison Decorative and Miniature Lamp Department,

(GENERAL ELECTRIC COMPANY,)

HARRISON, N. J.

## Complete Mineral Catalogue.

each element. Alphabetical index of names. Lists giving the specimen values of minerals, etc., etc. For teachers, students, collectors, mining experts, chemists, and others. *Postpaid; Paper, 35 cents; Cloth, 50 cents; Calf, interleaved, \$1.00.*

DR. A. E. FOOTE, 1317 Arch Street, Philadelphia, Pa., U. S. A.

Established 1876

COLLECTIONS OF MINERALS FOR STUDY OR REFERENCE.

CABINET SPECIMENS.

GEMS.

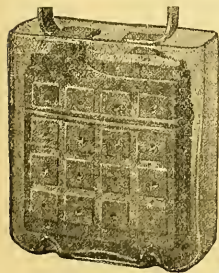

## Storage Batteries

*"There is no part of the equipment of a modern laboratory which is more useful than storage cells."*

*—Manual of Experiments in Physics; by Ames and Bliss.*

There is no Storage Battery better made or more widely used than the "Chloride Accumulator."

There is no one but the undersigned, specially authorized by the Electric Storage Battery Co. (makers of the "Chloride Accumulator"), to solicit LABORATORY ORDERS.

Correspondence requested. Catalogue A upon request.

James G. Biddle, 909 Drexel Building, Philadelphia.



**The Microscope and Microscopical Methods***Sixth Edition. Fully Illustrated.*

By SIMON HENRY GAGE, of Cornell University.

This book is a product of the laboratory and is designed for actual laboratory use. It deals with the modern microscope and its accessories, microscopical methods, including photo-micrography, etc., and has in view the especial needs of students, teachers and professional men. Postpaid, \$1.50

COMSTOCK PUBLISHING CO., Ithaca, N. Y.

JUST ISSUED.

**CRELLE, Calculating Tables.**

First English edition giving products of every two numbers from 1 to 1000.

Folio, cloth bound, . . . . . \$5.00

LEMCKE &amp; BUECHNER,

812 Broadway, New York.

**NEW CATALOGUE.**

We have recently issued a new edition, revised and enlarged to 64 pages, of our catalogue of

**Books on Chemistry, Chemical Technology and Physics.**

It is arranged by subjects, and includes all the standard books in Chemical and Physical Science, as well as the recent literature up to date.

A copy of this Catalogue will be sent free by mail to any address.

**D. Van Nostrand Company,**

Publishers and Importers of Scientific Books,

23 Murray St. and 27 Warren St., New York.

# Delicious Drink

**Horsford's Acid Phosphate**

with water and sugar only, makes a delicious, healthful and invigorating drink.

Allays the thirst, aids digestion, and relieves the lassitude so common in midsummer.

Dr. M. H. Henry, New York, says: "When completely tired out by prolonged wakefulness and overwork, it is of the greatest value to me. As a beverage it possesses charms beyond any think I know of in the form of medicine."

Descriptive pamphlet free on application to  
Rumford Chemical Works, Providence, R. I.  
Beware of Substitutes and Imitations.

**WM. GAERTNER & CO., Scientific Instrument Works**

152-156 Fifty-Sixth St., CHICAGO.

Manufacturers of ASTRONOMICAL AND PHYSICAL APPARATUS of modern design and high-grade workmanship. SPECIALTIES: Equatorial Telescopes, Micrometers, Spectroscopes, Linear and Circular Dividing Engines, Comparators, Michelson Interferometers, Bolometers, etc., etc. General Laboratory Apparatus, Universal Laboratory Supports.

*References from Leading Scientists. Catalogue on Application.***MAX KOHL, Chemnitz, Germany,**

FIRST EUROPEAN MAKER OF

**Physical and Electrical Instruments**

Special Manufacturer of Roentgen X-Ray Outfits.

Apparatus for Experiments with Currents of High Frequency and Tension.

Apparatus for the Experiments according to Hertz.

Apparatus for Marconi's Wireless Telegraphy.

Price List No. 10 of Physical Instruments; nearly 400 pages and more than 1300 engravings (in German, English and French). Special List of X-Ray Apparatus containing numerous testimonials as well as estimates for complete outfits, explicit directions for use, etc., in English language.

REFERENCES FROM LEADING EXPERTS.

Representative: Messrs. EIMER &amp; AMEND, 205-211 Third Avenue, New York.

EXTRA FINE CABINET SPECIMENS.  
RARE SPECIES. LOOSE CRYSTALS.  
CHEAP EDUCATIONAL SPECIMENS.  
SYSTEMATIC COLLECTIONS.  
BLOWPIPE MINERALS BY THE POUND.

**MINERALS.**

Our Stock greatly enriched by Mr. English's Recent Tour of Europe. Write for full particulars, and for free Price Lists and Bulletins. 124 pp. Catalogue (87 cuts) describing every species, 25c. in paper, 50c. in cloth.

**GEO. L. ENGLISH & CO., Mineralogists, 64 E. 12th St., New York.**

161964

# SCIENCE

NEW SERIES.  
VOL. VIII. No 195.

FRIDAY, SEPTEMBER 23, 1898.

SINGLE COPIES, 15 CTS.  
ANNUAL SUBSCRIPTION, \$5.00

## NEW GRAND MODEL.

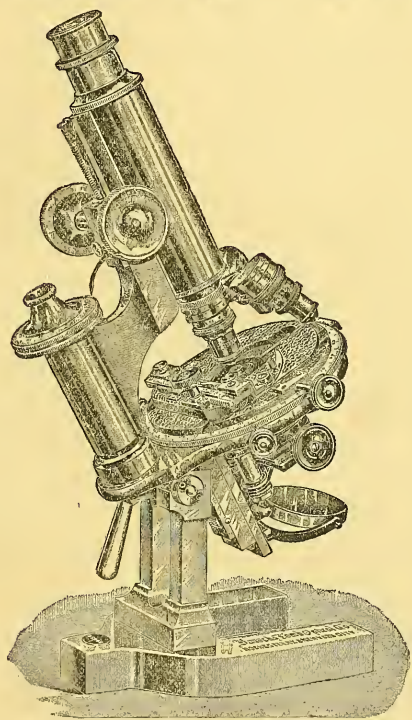

**DDS 8 Continental Microscope.**

Adapted especially for the more difficult Biological Work and for Photo-Micrography. Complete 264-page Catalogue and Supplement of Microscopes, Accessories and Laboratory Supplies mailed free.

### **BAUSCH & LOMB OPTICAL CO.**

CHICAGO:  
State and Washington Streets.

ROCHESTER, N. Y.

NEW YORK CITY:  
Broadway and 25th Street.

**S**EPARATA of the papers of the late Professor E. D. COPE are now for sale. Price list can be obtained by applying to Mrs. E. D. Cope, Haverford College, Haverford, Pa.

**THIN SECTIONS (Microscopic) OF ROCKS, MINERALS, FOSSILS, ETC.,** carefully mounted, and for sale at selection from list or in arranged collections, with descriptive commentaries (prepared by experienced lithologists). Corresponding rock specimens.

**GRINDING MACHINES** with latest improvements and fitted to foot power, electric motor, etc. Of best construction, but low in price; adapted to slicing and polishing all rock substances hard or soft; with suitable laps for preparation of thin sections for microscope. Send for circulars, GUSTAVUS D. JULIEN, 932 Bloomfield St., Hoboken, New Jersey.

**The Microscope and Microscopical Methods**  
*Sixth Edition. Fully Illustrated.*

By SIMON HENRY GAGE, of Cornell University. This book is a product of the laboratory and is designed for actual laboratory use. It deals with the modern microscope and its accessories, microscopical methods, including photo-micrography, etc., and has in view the especial needs of students, teachers and professional men. Postpaid, \$1.50  
COMSTOCK PUBLISHING CO., Ithaca, N. Y.

JUST ISSUED.

**CRELLE, Calculating Tables.**

First English edition giving products of every two numbers from 1 to 1000.

Folio, cloth bound, . . . . . \$5.00

LEMCKE & BUECHNER,

812 Broadway, New York.

# DYSPEPSIA

**Horsford's Acid Phosphate**

reaches various forms of Dyspepsia that no other medicine seems to touch. It assists the weakened stomach and makes the process of digestion natural and easy. Pleasant to take.

For sale by all Druggists

## PHYSICAL, CHEMICAL, MICROSCOPICAL AND ELECTRICAL APPARATUS.

Established  
1882.

COMPLETE LABORATORY EQUIPMENT OF OUR OWN MANUFACTURE.  
X-RAY APPARATUS AND CROOKE'S TUBES A SPECIALTY.

Incorporated  
1894.

Catalogue **P** Free to School  
Officials and Science Teachers.

**ZIEGLER ELECTRIC CO.,**

141 Franklin St..

BOSTON, MASS.

"Duty Free" Importations from  
Foreign Manufacturers.

## WM. GAERTNER & CO., Scientific Instrument Works

152-156 Fifty-Sixth St., CHICAGO.

Manufacturers of ASTRONOMICAL AND PHYSICAL APPARATUS of modern design and high-grade workmanship. SPECIALTIES: Equatorial Telescopes, Micrometers, Spectroscopes, Linear and Circular Dividing Engines, Comparators, Michelson Interferometers, Bolometers, etc., etc. General Laboratory Apparatus. Universal Laboratory Supports.

References from Leading Scientists. Catalogue on Application.

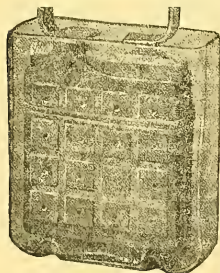

### Storage Batteries

"There is no part of the equipment of a modern laboratory which is more useful than storage cells."

—Manual of Experiments in Physics; by Ames and Bliss.

There is no Storage Battery better made or more widely used than the "Chloride Accumulator."

There is no one but the undersigned, specially authorized by the Electric Storage Battery Co. (makers of the "Chloride Accumulator"), to solicit LABORATORY ORDERS.

Correspondence requested. Catalogue A upon request.

**James G. Biddle, 909 Drexel Building, Philadelphia.**



112022

# SCIENCE

NEW SERIES.  
VOL. VIII. No 196.

FRIDAY, SEPTEMBER 30, 1898.

SINGLE COPIES, 15 CTS.  
ANNUAL SUBSCRIPTION, \$5.00

Trade Mark



## NOTICE.

Trade Mark



We are pleased to announce herewith to our patrons that since the fire which occurred on our premises, our stock has been promptly replenished, and inside of a week will be as deep and complete as heretofore.

All goods of the famous European makers whom we represent in the United States, like :

**Messrs. Schott & Genossen** for Jena Normal Glass,  
**Messrs. Schleicher & Schuell** for chemically pure Filters,  
**Messrs. Schmidt & Haensch** for Optical apparatus,  
**Max Kohl** for Physical Apparatus, etc., etc.,

have again arrived in larger quantities.

Besides carrying the *highest* grade of European microscopes as made by **Carl Zeiss of Jena**, we now also represent **THE SPENCER LENS COMPANY**, of Buffalo, whose microscopes we carry on hand as sole agents for the New York market.

The **Spencer Lenses** rank next to Zeiss'; as to their general efficiency.

We have also taken the sole agency for New York for all the goods manufactured by **The Baker & Adamson Chemical Co.**, whose chemicals have become a standard for excellency and purity. All chemicals which they make will be carried on hand in considerable quantities. Chemicals not of their make are of Kahlbaum's and other prominent European manufacture.

We will now again be able to fill orders as promptly as heretofore, and soliciting your trade, we remain,

Yours respectfully,

## EIMER & AMEND,

Trade Mark



Manufacturers and  
Importers of

Scientific Apparatus, Chem-  
icals and all Utensils for the  
Chemical Laboratory.

205, 207, 209, 211 Third Ave.,

NEW YORK.

Trade Mark



**S**EPARATA of the papers of the late Professor E. D. COPE are now for sale. Price list can be obtained by applying to Mrs. E. D. Cope, Haverford College, Haverford, Pa.

**THIN SECTIONS (Microscopic) OF ROCKS, MINERALS, FOSSILS, ETC.,** carefully mounted, and for sale at selection from list or in arranged collections, with descriptive commentaries (prepared by experienced lithologists). Corresponding rock specimens.

**GRINDING MACHINES** with latest improvements and fitted to foot power, electric motor, etc. Of best construction, but low in price; adapted to slicing and polishing all rock substances hard or soft; with suitable laps for preparation of thin sections for microscope. Send for circulars, GUSTAVUS D. JULIEN, 932 Bloomfield St., Hoboken, New Jersey.

**The Microscope and Microscopical Methods**  
*Sixth Edition. Fully Illustrated.*

By SIMON HENRY GAGE, of Cornell University.

This book is a product of the laboratory and is designed for actual laboratory use. It deals with the modern microscope and its accessories, microscopical methods, including photo-micrography, etc., and has in view the special needs of students, teachers and professional men. Postpaid, \$1.50  
COMSTOCK PUBLISHING CO., Ithaca, N. Y.

JUST ISSUED.

**CRELLE, Calculating Tables.**

First English edition giving products of every two numbers from 1 to 1000.

Folio, cloth bound, . . . . . \$5.00

LEMCKE & BUECHNER,

812 Broadway, New York.

# DYSPEPSIA

**Horsford's Acid Phosphate** reaches various forms of Dyspepsia that no other medicine seems to touch. It assists the weakened stomach and makes the process of digestion natural and easy. Pleasant to take.

For sale by all Druggists

## LIVING PLANTS and their Properties

By Professor J. C. ARTHUR, Purdue University, and Professor D. T. MacDOUGAL, University of Minnesota.

A book of 12 independent essays dealing with such subjects as special senses of plants, influence of cold, significance of color, comparisons between plants and animals, etc.

Enamelled Paper, Marginal Sub-Titles, 30 Illustrations, 242 Pages, 8vo, handsomely bound in Cloth. Price, \$1.25 postpaid.

### COMMENTS.

"It is a collection of delightfully written essays on certain of the more important and interesting features of living plants in the broadest sense."—*Plant World*.

"A most attractive, popular presentation based upon sound, scientific knowledge."—PAUL CARUS.

"The book will make an interesting addition to the scientific alcove of every public library."—Prof. C. E. BESSEY.

"The authors consistently indicate the fundamental identity of animals and plants and show that this is due to their having the same living substance as their physical basis of existence."—G. J. PIERCE.

BAKER & TAYLOR CO.,

5 and 7 East 16th Street, NEW YORK CITY.

MORRIS & WILSON,

University Book Store, MINNEAPOLIS, MINN.

## WM. GAERTNER & CO., Scientific Instrument Works

152-156 Fifty-Sixth St., CHICAGO.

Manufacturers of ASTRONOMICAL AND PHYSICAL APPARATUS of modern design and high-grade workmanship. SPECIALTIES: Equatorial Telescopes, Micrometers, Spectroscopes, Linear and Circular Dividing Engines, Comparators, Michelson Interferometers, Bolometers, etc., etc. General Laboratory Apparatus, Universal Laboratory Supports.

References from Leading Scientists. Catalogue on Application.

## MINERALS.

EXTRA FINE CABINET SPECIMENS.  
RARE SPECIES. LOOSE CRYSTALS.  
CHEAP EDUCATIONAL SPECIMENS.  
SYSTEMATIC COLLECTIONS.

BLOWPIPE MINERALS BY THE POUND.

Our Stock greatly enriched by Mr. English's Recent Tour of Europe. Write for full particulars, and for free Price Lists and Bulletins. 124 pp. Catalogue (87 cuts) describing every species, 25c. in paper, 50c. in cloth.

GEO. L. ENGLISH & CO., Mineralogists, 64 E. 12th St., New York.

# SCIENCE

NEW SERIES.  
VOL. VIII. No 197.

FRIDAY, OCTOBER 7, 1898.

SINGLE COPIES, 15 CTS.  
ANNUAL SUBSCRIPTION, \$5.00



## GENERAL ELECTRIC CO.'S FLUOROSCOPES

Platino-cyanide of Barium, or Tungstate of Calcium Screens.

**NEW X-RAY TUBE** WITH AUTOMATIC  
VACUUM REGULATOR.  
*SIMPLE. EFFICIENT. LONG-LIVED.*

**ROENTGEN RAY APPARATUS** of all kinds.

Catalogue No. 9050.

**Candelabra, Miniature and Decorative Lamps.**

Catalogue No. 9044.

**Edison Decorative and Miniature Lamp Department,**

(GENERAL ELECTRIC COMPANY.)

**HARRISON, N. J.**



**Shells at Discount.** An extensive private collection of shells has been placed with us for sale. These are offered at a discount from regular prices in order to close them out rapidly. List will be sent on application.

Our new **SHELL CATALOGUE**, 170 pages, over 200 illustrations, descriptions of Classes, Orders and Families. Price, 40 cents, postpaid.

**WARD'S NATURAL SCIENCE ESTABLISHMENT, ROCHESTER, N. Y.**

## Apparatus for Psychological Laboratories

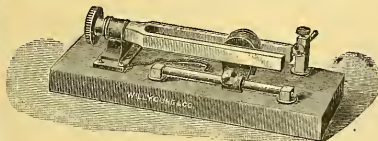

Student's Electro-Magnetic Fork, S5a.

Last May I issued a revised catalogue of Psychological Apparatus, No. 300. Every college professor interested in the subject should write for a copy, as it is free to such.

I have equipped some of the best American laboratories. I make a specialty of apparatus manufactured by Willyoung & Co., but in addition import from Cambridge Scientific Instrument Co., Verdin, Koenig, Petzold, Zimmerman and other prominent European makers. Correspondence requested.

**JAMES G. BIDDLE, 909 Drexel Building, Philadelphia, Pa.**



**THIN SECTIONS (Microscopic)  
OF ROCKS, MINERALS, FOSSILS, ETC.,**  
carefully mounted, and for sale at selection from list or in arranged collections, with descriptive commentaries (prepared by experienced lithologists). Corresponding rock specimens.

**GRINDING MACHINES**

with latest improvements and fitted to foot power, electric motor, etc. Of best construction, but low in price; adapted to slicing and polishing all rock substances hard or soft; with suitable lens for preparation of thin sections for microscope. Send for circulars. GUSTAVUS D. JULIEN, 932 Bloomfield St., Hoboken, New Jersey.

**CRELLE, Calculating Tables.**

English Text. Cloth, \$5.00.

**BREMKER, Logarithmic Tables.**

(6 places). Cloth, \$1.85.

**BRUHNS, Logarithmic Tables.**

(7 places).  $\frac{1}{2}$  Mor., \$2.50.

**VEGA, Logarithmic Tables.**

(7 places).  $\frac{1}{2}$  Mor., \$2.50.

**LEMCKE & BUECHNER,**

812 Broadway, New York.

**NEW CATALOGUE.**

We have recently issued a new edition, revised and enlarged to 64 pages, of our catalogue of

**Books on Chemistry, Chemical  
Technology and Physics.**

It is arranged by subjects, and includes all the standard books in Chemical and Physical Science, as well as the recent literature up to date.

A copy of this Catalogue will be sent free by mail to any address.

**D. Van Nostrand Company,**

Publishers and Importers of Scientific Books,

23 Murray St. and 27 Warren St., New York.

# Delicious Drink

## Horsford's Acid Phosphate

with water and sugar only, makes a delicious, healthful and invigorating drink.

Allays the thirst, aids digestion, and relieves the lassitude so common in midsummer.

Dr. M. H. Henry, New York, says: "When completely tired out by prolonged wakefulness and overwork, it is of the greatest value to me. As a beverage it possesses charms beyond any-think I know of in the form of medicine."

Descriptive pamphlet free on application to

Rumford Chemical Works, Providence, R. I.

Beware of Substitutes and Imitations.

## MAX KOHL, Chemnitz, Germany,

FIRST EUROPEAN MAKER OF

# Physical and Electrical Instruments

Special Manufacturer of Roentgen X-Ray Outfits.

Apparatus for Experiments with Currents of High Frequency and Tension.

Apparatus for the Experiments according to Hertz.

Apparatus for Marconi's Wireless Telegraphy.

Price List No. 10 of Physical Instruments; nearly 400 pages and more than 1300 engravings (in German, English and French). Special List of X-Ray Apparatus containing numerous testimonials as well as estimates for complete outfits, explicit directions for use, etc., in English language.

— REFERENCES FROM LEADING EXPERTS. —

Representative: Messrs. EIMER & AMEND, 205-211 Third Avenue, New York.

## WM. GAERTNER & CO., Scientific Instrument Works

152-156 Fifty-Sixth St., CHICAGO.

Manufacturers of ASTRONOMICAL AND PHYSICAL APPARATUS of modern design and high-grade workmanship. SPECIALTIES: Equatorial Telescopes, Micrometers, Spectroscopes, Linear and Circular Dividing Engines, Comparators, Michelson Interferometers, Bolometers, etc., etc. General Laboratory Apparatus. Universal Laboratory Supports.

References from Leading Scientists. Catalogue on Application.

# MINERALS.

EXTRA FINE CABINET SPECIMENS.  
RARE SPECIES. LOOSE CRYSTALS.  
CHEAP EDUCATIONAL SPECIMENS.  
SYSTEMATIC COLLECTIONS.  
BLOWPIPE MINERALS BY THE POUND.

Our Stock greatly enriched by Mr. English's Recent Tour of Europe. Write for full particulars, and for free Price Lists and Bulletins. 124 pp. Catalogue (57 cuts) describing every species, 25c. in paper, 50c. in cloth.

**GEO. L. ENGLISH & CO., Mineralogists, 64 E. 12th St., New York.**

# SCIENCE

NEW SERIES.  
VOL. VIII. No. 198.

FRIDAY, OCTOBER 14, 1898.

SINGLE COPIES, 15 CTS.  
ANNUAL SUBSCRIPTION, \$5.00.

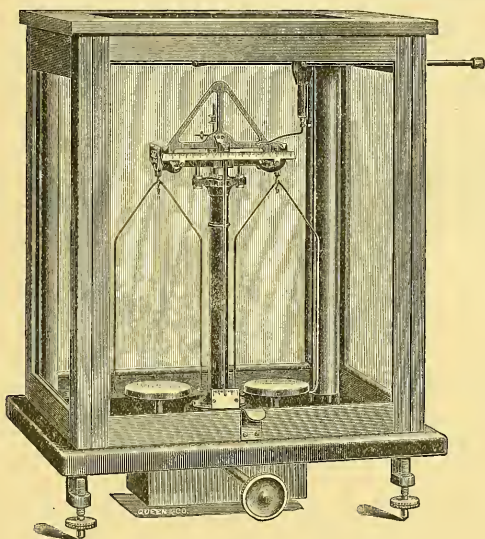

No. 3.

## CHEMICAL APPARATUS AND CHEMICALS.

Queen & Co.'s No. 3 Analytical Balance has agate bearings and knives, short aluminum beam, a capacity of 200 grms., a sensibility of  $\frac{1}{10}$  m. g., and sells for **\$55.00**. A splendid instrument for students' use.

### QUEEN & CO., INC.,

... Optical and Scientific Instrument Works, ...

New York Branch: 59 Fifth Ave.

1010 CHESTNUT ST., PHILADELPHIA.

*Absolutely Reliable Always*

# Remington

Standard Typewriter.

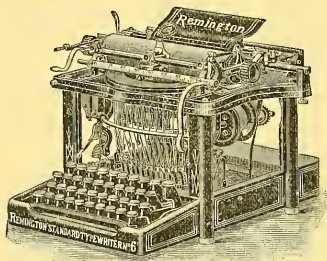

NEW MODELS.

Wyckoff, Seamans & Benedict  
327 Broadway, New York.

**THIN SECTIONS (Microscopic)**  
**OF ROCKS, MINERALS, FOSSILS, ETC.,**  
carefully mounted, and for sale at selection from list or in arranged collections, with descriptive commentaries (prepared by experienced lithologists). Corresponding rock specimens.

### GRINDING MACHINES

with latest improvements and fitted to foot power, electric motor, etc. Of best construction, but low in price; adapted to slicing and polishing all rock substances hard or soft; with suitable laps for preparation of thin sections for microscope. Send for circulars.  
GUSTAVUS D. JULIEN, 932 Bloomfield St., Hoboken, New Jersey.

**The Microscope and Microscopical Methods**  
*Sixth Edition. Fully Illustrated.*

By SIMON HENRY GAGE, of Cornell University.

This book is a product of the laboratory and is designed for actual laboratory use. It deals with the modern microscope and its accessories, microscopical methods, including photo-micrography, etc., and has in view the especial needs of students, teachers and professional men. Postpaid, \$1.50  
COMSTOCK PUBLISHING CO., Ithaca, N. Y.

**WM. GAERTNER & CO., Scientific Instrument Works**  
152-156 Fifty-Sixth St., CHICAGO.

Manufacturers of **ASTRONOMICAL AND PHYSICAL APPARATUS** of modern design and high-grade workmanship. **SPECIALTIES:** Equatorial Telescopes, Micrometers, Spectroscopes, Linear and Circular Dividing Engines, Comparators, Michelson Interferometers, Bolometers, etc., etc. General Laboratory Apparatus. Universal Laboratory Supports.

*References from Leading Scientists. Catalogue on Application.*

# MINERALS.

*Our Stock greatly enriched by Mr. English's Recent Tour of Europe. Write for full particulars, and for free Price Lists and Bulletins. 124 pp. Catalogue (87 cuts) describing every species, 25c. in paper, 50c. in cloth.*

**GEO. L. ENGLISH & CO., Mineralogists, 64 E. 12th St., New York.**

# DYSPEPSIA

Horsford's Acid Phosphate reaches various forms of Dyspepsia that no other medicine seems to touch. It assists the weakened stomach and makes the process of digestion natural and easy. Pleasant to take.

For sale by all Druggists

## NEW CATALOGUE.

We have recently issued a new edition, revised and enlarged to 64 pages, of our catalogue of

### Books on Chemistry, Chemical Technology and Physics.

It is arranged by subjects, and includes all the standard books in Chemical and Physical Science, as well as the recent literature up to date.

A copy of this Catalogue will be sent free by mail to any address.

**D. Van Nostrand Company,**

Publishers and Importers of Scientific Books,

23 Murray St. and 27 Warren St., New York.

**EXTRA FINE CABINET SPECIMENS.**  
**RARE SPECIES. LOOSE CRYSTALS.**  
**CHEAP EDUCATIONAL SPECIMENS.**  
**SYSTEMATIC COLLECTIONS.**  
**BLOWPIPE MINERALS BY THE POUND.**



# SCIENCE

NEW SERIES.  
VOL. VIII. No. 199.

FRIDAY, OCTOBER 21, 1898.

SINGLE COPIES, 15 CTS.  
ANNUAL SUBSCRIPTION, \$5.00\*



## GENERAL ELECTRIC CO.'S NEW X-RAY TUBE

WITH AUTOMATIC VACUUM REGULATOR.

Simple. Efficient. Long-lived. Cannot run too high in vacuum.

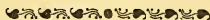

Roentgen Ray Apparatus, catalogue No. 9,050. Miniature, Candelabra, Decorative Lamps, catalogue No. 9,044.

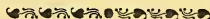

### Edison Decorative and Miniature Lamp Department,

(GENERAL ELECTRIC COMPANY,)

HARRISON, N. J.

## NEW BOOKS AND NEW EDITIONS

### Text-Book of Geodetic Astronomy

By JOHN F. HAYFORD, C.E. 8vo, cloth, \$3.00.

### The Theory of Electrical Measurements

By WILLIAM A. ANTHONY, Professor of Physics. 12mo, cloth, \$1.00.

### The Elements of Sanitary Engineering

By Prof. MANSFIELD MERRIMAN. 8vo, cloth, \$2.00.

### A Text-Book of Volumetric Analysis with Special Reference to the Volumetric Processes of the Pharmacopodia of the United States

Designed for the Use of Pharmacists and Pharmaceutical Students. By HENRY W. SCHIMPF, Ph.G., M.D. Rewritten and Reset. 12mo, cloth, \$2.50.

### A Text-Book of Mineralogy with an Extended Treatise on Crystallography and Physical Mineralogy

By EDWARD SALISBURY DANA. New Edition, entirely Rewritten and Reset. With nearly 1,000 figures and a colored plate. 8vo, cloth, \$4.00.

### Thermo-Dynamics of the Steam-Engine and Other Heat Engines

By C. H. PEABODY. 4th Edition. Rewritten and Reset. 8vo, cloth, \$5.00.

### Manual of Determinative Mineralogy

With an Introduction of Blowpipe Analysis. By GEORGE J. BRUSH. Revised and enlarged, with entirely new tables for the identification of minerals. By SAMUEL L. PENFIELD. Fifteenth Edition. 8vo, cloth, \$4.00.

JOHN WILEY & SONS, 53 E. 10th St., New York City

# NEW SCIENTIFIC BOOKS

PUBLISHED BY  
THE MACMILLAN COMPANY.

## BOTANY.

### A Text-Book on Botany.

By DR. EDWARD STRASBURGER aided by DRs. NOLL, SCHENCK and SCHIMPER.

"To give a volume this designation is to doom it beforehand to exclusion from the hands of the general reader.

Perhaps the few words which follow may do something to avert from the charming treatise mentioned at the head of this article a fate so undeserved. In the first place, the whole appearance of the work is attractive; in the second place, this attractiveness of appearance is associated throughout with a most skilful presentation of fundamental facts and essential principles. The translation is clear and strong, and remarkably free from slips of any importance.—*The Nation*.

Translated

by

HENRY C. PORTER, Ph.D.,  
*University of Pennsylvania.*

Price complete in one volume,  
\$1.50 net.

Separately, cloth, \$8.00.

Part I., \$2.50 net.

Part II., \$2.50 net.

"The volume in its German dress is so well known to botanists that it is quite needless to speak of its merits. Perhaps no man living is better prepared than Dr. Strasburger to undertake the presentation of the portion of the work which deals with the internal morphology of plants. Certainly no man has a better knowledge of the structure of the cell, and the many changes which it undergoes in constitution and form."—*Science*.

With over 500 illustrations, in part colored.

Part I. Morphology and Physiology.

Part II. Cryptogams and Phanerogams.

## NEW BOOKS BY PROFESSOR BAILEY.

### The Evolution of Our Native Fruits.

A companion volume to "The Survival of the Unlike" (an attempt to extend the theory of evolution to the practice of horticulture) and written on the same original lines. It is copiously illustrated.

By

Professor L. H. BAILEY,  
*Cornell University.*

Author of the volumes in the  
**Garden-Craft Series,**  
etc., etc., etc.  
Cloth, 12mo, \$2.00.

Of the earlier work G. H. Powell of the Del. Agr. College wrote: "It is the most valuable series of writings extant in which the operations of horticulture are referred to laws which govern the evolution of the organic world."

### Lessons With Plants.

Profusely illustrated with delineations from nature by W. S. Holdsworth, Assistant Professor of Drawing in the Agricultural College of Michigan, carefully chosen and well-executed.

**Suggestions for Seeing and Interpreting some of the Common Forms of Vegetation.**

Half Leather, 12mo, \$1.10.

"It is an admirable book and cannot fail both to awaken interest in the subject and to serve as a helpful and reliable guide to young students of plant life."—Prof. V. M. SPALDING, Univ. of Michigan,

### First Lessons With Plants.

All of the illustrations of the original appear in these selected chapters which are in no way abbreviated.

**The First Twenty Chapters of the Larger Work Described Above.**

Cloth, 12mo, 40 cents.

"A remarkably well-printed and illustrated book, extremely original and unusually practical."—H. W. FOSTER, Ithaca, N. Y.

THE MACMILLAN COMPANY

New York

Boston

Chicago

San Francisco

# SCIENCE

NEW SERIES,  
VOL. VIII. No. 200.

FRIDAY, OCTOBER 28, 1898.

SINGLE COPIES, 15 CTS.  
ANNUAL SUBSCRIPTION, \$5.00.

## NEW GRAND MODEL.

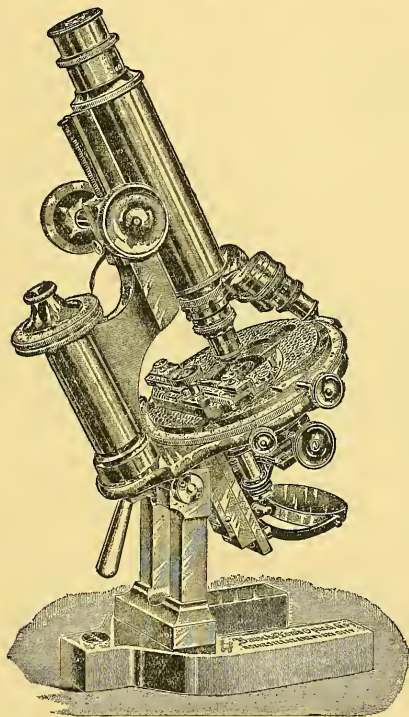

**DDS 8 Continental Microscope.**

Adapted especially for the more difficult Biological Work and for Photo-Micrography. Complete 264-page Catalogue and Supplement of Microscopes, Accessories and Laboratory Supplies mailed free.

**BAUSCH & LOMB OPTICAL CO.**

CHICAGO:  
State and Washington Streets.

ROCHESTER, N. Y.

NEW YORK CITY:  
Broadway and 25th Street.



# New Books on Nature Study

## HANDBOOKS FOR TEACHERS.

### A Handbook of Nature Study for Teachers and Pupils in Elementary Schools.

"A valuable primer to natural history and science . . . thoroughly practical."—*Scientific American*.

"Intended to interest a child in observing the growing and moving world about him. Trees and plants, insects and birds are treated of in a very simple and interesting manner. The style is calculated to hold the attention and the illustrations are numerous."—*The Churchman*.

"Altogether the book is an admirable one."—*Forest and Stream*.

BY

D. LANGE,

Instructor in Nature Study in the  
Public Schools of St. Paul,  
Minnesota.

With many Illustrations, an Appendix and Index.

12mo, Cloth. Price, \$1.00 net.

The purpose of the book is to furnish teachers in common schools with material and suggestions with which to make their pupils acquainted with the plant and animal life around them. The material is arranged according to seasons and life communities; and the author has taken special pains to show some of the relations existing between the vegetable and animal kingdoms, animate and inanimate nature, and between man and nature.

### Nature Study in Elementary Schools.

BY

Mrs. Lucy L. W. Wilson, Ph.D.,

Philadelphia Normal School  
for Girls.

Part I. *Manual for Teachers*.  
Cloth, 16mo, 90 cents net.

Part II. *Reader: Myths, Stories and Poems*. Small  
12mo, Cloth. Price, 35 cents net.

We have seen no book along this line that is more stimulating and inspiring. It shows the teacher just how to go to work to get the pupils interested and to make them observant. This is a modern subject and it is handled in this volume in a modern and masterly manner. We commend the work to all teachers and parents.

The original matter in this reader has been written and the selections chosen with the desire of putting into the hands of little children literature which shall have, for their minds, the same interest and value that really good books and magazines have for grown-up people. It is the author's aim to plant the seeds of that which may later develop into a taste for art, for literature and for nature.

## A COMPANION VOLUME TO "CITIZEN BIRD"

### Four-Footed Americans and Their Kin.

BY

MABEL OSGOOD WRIGHT,

Author of "Citizen Bird," etc.  
Edited by Frank M. Chapman.  
Seventy-two Original Illustrations  
by Ernest Seton Thompson,  
among many others.

Cloth, 12mo, \$1.50 net.

"'Four-footed Americans' is not a text-book to be taken by children like a sugar-coated pill, with a doubtful if not a wry face, but a volume breezily and brightly written, yet crammed with matter every child should know."—*N. Y. Times*.

"An interesting, odd story underlies the relation in these thirty chapters of the life-histories of seventy-five or more of American mammals, not only the four-footed, but the wing-handed-batkin, and the footless whale of American waters. It is the only adequate book of its kind."—*Book Reviews*.

## THE MACMILLAN COMPANY

New York

Boston

Chicago

San Francisco

# SCIENCE

NEW SERIES.  
VOL. VIII. No. 201.

FRIDAY, NOVEMBER 4, 1898.

SINGLE COPIES, 15 CTS.  
ANNUAL SUBSCRIPTION, \$5.00.

**AN IMPORTANT WORK**

## Text-Book of Physical Chemistry

By

**CLARENCE L. SPEYERS**

ASSOCIATE PROFESSOR OF CHEMISTRY, RUTGERS COLLEGE

**CONTENTS:** Chap. I.—Some General Remarks on Energy. Chap. II.—Gases. Chap. III.—Heat, Chap. IV.—Physical Changes. Chap. V.—Equilibrium. Chap. VI.—Chemical Kinetics. Chap. VII.—Phases. Chap. VIII.—When Temperature is Variable. Chap. IX.—Electro-Chemistry. Chap. X.—Ions. Tables.

One Volume, Svo, Cloth, 232 pages. Price, net, \$2.25

**D. VAN NOSTRAND COMPANY, Publishers**

\*,\* Copies sent by mail on receipt of price.

23 Murray and 27 Warren Sts., New York



**MINIATURE INCANDESCENT LAMPS.  
MINIATURE LAMP RECEPTACLES.  
X-RAY TUBES AND APPARATUS.  
FLUOROSCOPES.**

Catalogues on Application.

**Edison Decorative and Miniature Lamp Department,**

(GENERAL ELECTRIC COMPANY.)

**HARRISON, N. J.**

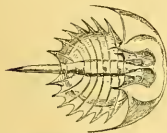

## Fossils.

We have a large assortment of specimens from all Ages, covering the entire Biological range of the subject. Plants, Protozoans, Corals, Crinoids, Brachiopods, Trilobites, etc., etc. We prepare various **Systematic Collections** of these for use in **Schools and Colleges**. Catalogues of these collections will be sent to teachers who intend purchasing.

**WARD'S NATURAL SCIENCE ESTABLISHMENT, R chester, N. Y.**

## My New Catalogue B

relates to **Electrical Measuring Instruments**. It is comprehensive, well illustrated, and contains more than 100 pages. *Just Issued*. Send 10 cents in stamps, for a copy.

**JAMES G. BIDDLE,**

910 Drexel Building, Philadelphia.

# Timely Books of General Interest

## The Philippine Islands and Their People

A Record of Personal Observation and Experience, with a Short Summary of the More Important Facts in the History of the Archipelago. By DEAN C. WORCESTER, Assistant Professor of Zoology, University of Michigan. **Svo. Cloth Extra. Price, \$1.00.**

This is no mere record of an ordinary traveller. Professor Worcester twice visited the Philippines. On his second trip he remained nearly three years in the islands, and a royal order from the Spanish Government materially aided him in gathering information. Dr. Frank S. Bourns, now on the staff of the commander-in-chief of our forces at Manila, was with the author on both of his visits, and has furnished a large number of photographs from which the illustrations have been made.

## The Control of the Tropics

By BENJAMIN KIDD, Author of "Social Evolution." **12mo. Cloth. Price, 75 cents.**

The appearance of Mr. Kidd's book is particularly timely, and as it deals especially with problems which are now confronting us, its circulation has been very extended; the first edition is about exhausted, and a second is in active preparation.

"Mr. Kidd's thinking is close and logical and his conclusions are well worthy of thoughtful consideration."—*The Tribune*, Chicago.

## The Rise and Growth of American Politics

A Sketch of Constitutional Development. By HENRY JONES FORD. **12mo. Cloth. \$1.50.**

Mr. Ford has set himself a difficult task. From their inception he reviews our politics from the standpoint of an outsider, as Mr. Bryce did in his "American Commonwealth." Yet it is an explanation of causes rather than a narrative of events, aiming to give the reader an understanding of the actual system of government under which we live.

To the student, whether of constitutional history or of political parties, the book is not only readable, but of great value.

## An Outline of Philosophy

With Notes Historical and Critical. By JOHN WATSON, LL.D., Professor of Moral Philosophy in Queen's University, Kingston, Canada; Author of "Kant and his English Critics," etc. *2nd Edition.* **12mo. Cloth. Price, \$2.25 net.**

The first edition of this work was published under the title of "Comte, Mill, and Spencer: an Outline of Philosophy." The call for a second edition has been answered by the author with a completely revised and partially rewritten text.

## Guesses at the Riddle of Existence,

And Other Essays on Kindred Subjects. New Edition, with Additions. By GOLDWIN SMITH, D.C.L. **12mo. Cloth. Price, \$1.25.**

The constant demand for this book has brought about a new edition, in which several additions have been made to the text.

"Incisive in thought, fearless and honest in spirit."—*Chicago Tribune*.

## The Gospel for an Age of Doubt

By HENRY VAN DYKE, D.D. (Princeton, Harvard, Yale), LL.D. (Union), Pastor of the Brick Church in New York. *Sixth Edition Revised, with a New Preface.* **12mo. Cloth. Price, \$1.25.**

This, the sixth edition, contains an entirely new preface of considerable length. The book is now issued in a cheaper form and will doubtless attract many new readers.

"It is the best one of a very few books I should venture to put into the hands of a young man troubled by doubts."—JAMES O. MURRAY, D.D., *Dean of Princeton University.*

**THE MACMILLAN COMPANY**

New York

Boston

Chicago

San Francisco



16237

# SCIENCE

NEW SERIES.  
VOL. VIII. No. 202.

FRIDAY, NOVEMBER 11, 1898.

SINGLE COPIES, 15 CTS.  
ANNUAL SUBSCRIPTION, \$5.00.

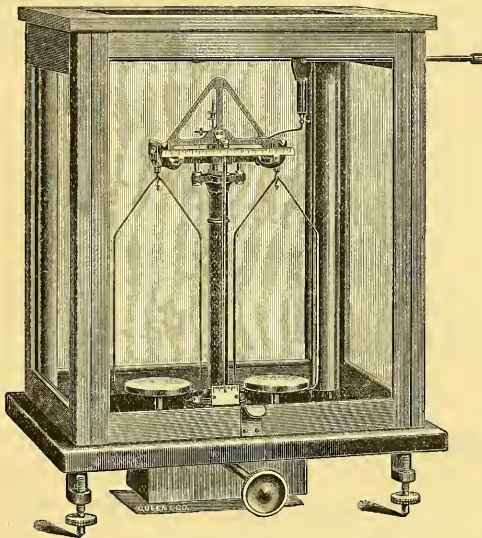

No. 3.

## CHEMICAL APPARATUS AND CHEMICALS.

Queen & Co.'s No. 3 Analytical Balance has agate bearings and knives, short aluminum beam, a capacity of 200 grms., a sensibility of  $\frac{1}{10}$  m. g., and sells for **\$55.00**. A splendid instrument for students' use.

### QUEEN & CO., INC.,

... Optical and Scientific Instrument Works, ...

New York Branch: 59 Fifth Ave.

1010 CHESTNUT ST., PHILADELPHIA.

# Timely Books of General Interest

## The Philippine Islands and Their People

A Record of Personal Observation and Experience, with a Short Summary of the More Important Facts in the History of the Archipelago. By DEAN C. WORCESTER, Assistant Professor of Zoology, University of Michigan. **Svo. Cloth Extra. Price, \$4.00.**

This is no mere record of an ordinary traveller. Professor Worcester twice visited the Philippines. On his second trip he remained nearly three years in the islands, and a royal order from the Spanish Government materially aided him in gathering information. Dr. Frank S. Bonrns, now on the staff of the commander-in-chief of our forces at Manila, was with the author on both of his visits, and has furnished a large number of photographs from which the illustrations have been made.

## The Control of the Tropics

By BENJAMIN KIDD, Author of "Social Evolution." **12mo. Cloth. Price, 75 cents.**

The appearance of Mr. Kidd's book is particularly timely, and as it deals especially with problems which are now confronting us, its circulation has been very extended; the first edition is about exhausted, and a second is in active preparation.

"Mr. Kidd's thinking is close and logical and his conclusions are well worthy of thoughtful consideration."—*The Tribune*, Chicago.

## The Rise and Growth of American Politics

A Sketch of Constitutional Development. By HENRY JONES FORD. **12mo. Cloth. \$1.50.**

Mr. Ford has set himself a difficult task. From their inception he reviews our politics from the standpoint of an outsider, as Mr. Bryce did in his "American Commonwealth." Yet it is an explanation of causes rather than a narrative of events, aiming to give the reader an understanding of the actual system of government under which we live.

To the student, whether of constitutional history or of political parties, the book is not only readable, but of great value.

## An Outline of Philosophy

With Notes Historical and Critical. By JOHN WATSON, LL.D., Professor of Moral Philosophy in Queen's University, Kingston, Canada; Author of "Kant and his English Critics," etc. *2nd Edition.*

**12mo. Cloth. Price, \$2.25 net.**

The first edition of this work was published under the title of "Comte, Mill, and Spencer: an Outline of Philosophy." The call for a second edition has been answered by the author with a completely revised and partially rewritten text.

## Guesses at the Riddle of Existence,

And Other Essays on Kindred Subjects. New Edition, with Additions. By GOLDWIN SMITH, D.C.L. **12mo. Cloth. Price, \$1.25.**

The constant demand for this book has brought about a new edition, in which several additions have been made to the text.

"Incisive in thought, fearless and honest in spirit."—*Chicago Tribune*.

## The Gospel for an Age of Doubt

By HENRY VAN DYKE, D.D. (Princeton, Harvard, Yale), LL.D. (Union), Pastor of the Brick Church in New York. *Sixth Edition Revised, with a New Preface.* **12mo. Cloth. Price, \$1.25.**

This, the sixth edition, contains an entirely new preface of considerable length. The book is now issued in a cheaper form and will doubtless attract many new readers.

"It is the best one of a very few books I should venture to put into the hands of a young man troubled by doubts."—JAMES O. MURRAY, D.D., *Dean of Princeton University.*

FOR HOLIDAY BOOKS SEND FOR OUR CHRISTMAS CATALOGUE.

**THE MACMILLAN COMPANY**

New York

Boston

Chicago

San Francisco

# SCIENCE

NEW SERIES.  
VOL. VIII. No. 203.

FRIDAY, NOVEMBER 18, 1898.

SINGLE COPIES, 15 CTS.  
ANNUAL SUBSCRIPTION, \$5.00.

## Chemical and Physical Apparatus

### CHEMICAL PURE ACIDS AND CHEMICALS

SELLING AGENTS FOR

Spencer  
Lens  
Company  
and  
Carl  
Zeiss,  
Jena

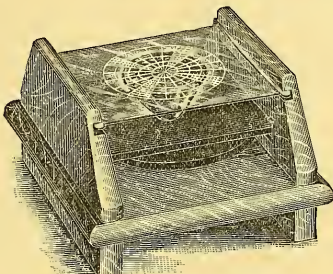

Mason-Miller-McPherson Bacteria Counter



Baker &  
Adamson  
Chemical Co.  
and  
Desmontis,  
Lemaire & Co.'s  
Platinum

SOLE AGENTS FOR

SCHOTT & GONOSSEN, JENA NORMAL GLASS  
SCHLEICHER & SCHÜLL'S CHEM. PURE FILTERS  
SCHMIDT & HAENSCH'S OPTICAL APPARATUS  
MAX KOHL'S PHYSICAL APPARATUS

Trade Mark



## EIMER & AMEND

Trade Mark



205, 207, 209, 211 Third Ave.

NEW YORK



# Timely Books of General Interest

## The Philippine Islands and Their People

A Record of Personal Observation and Experience, with a Short Summary of the More Important Facts in the History of the Archipelago. By DEAN C. WORCESTER, Assistant Professor of Zoology, University of Michigan. **Svo. Cloth Extra. Price, \$4.00.**

"Full of unexpected information, and still more full of material, interestingly presented, which elaborates the facts regarding the Spanish domination in the Philippines. . . . We strongly recommend this volume, first, because of the great variety and diversity of its information, which is well and discriminatingly presented; and, second, on account of the inherent interest of the whole volume, which is as absorbing, though of course in a different way, as a good adventure story."—*The Herald*, Boston.

## The Control of the Tropics

By BENJAMIN KIDD, Author of "Social Evolution." **12mo. Cloth. Price, 75 cents.**

The appearance of Mr. Kidd's book is particularly timely, and as it deals especially with problems which are now confronting us, its circulation has been very extended; the first edition is about exhausted, and a second is in active preparation.

"Mr. Kidd's thinking is close and logical and his conclusions are well worthy of thoughtful consideration."—*The Tribune*, Chicago.

## The Rise and Growth of American Politics

A Sketch of Constitutional Development. By HENRY JONES FORD. **12mo. Cloth. \$1.50.**

Mr. Ford has set himself a difficult task. From their inception he reviews our politics from the standpoint of an outsider, as Mr. Bryce did in his "American Commonwealth." Yet it is an explanation of causes rather than a narrative of events, aiming to give the reader an understanding of the actual system of government under which we live.

To the student, whether of constitutional history or of political parties, the book is not only readable, but of great value.

## An Outline of Philosophy

With Notes Historical and Critical. By JOHN WATSON, LL.D., Professor of Moral Philosophy in Queen's University, Kingston, Canada; Author of "Kant and his English Critics," etc. *2nd Edition.*

**12mo. Cloth. Price, \$2.25 net.**

The first edition of this work was published under the title of "Comte, Mill, and Spencer: an Outline of Philosophy." The call for a second edition has been answered by the author with a completely revised and partially rewritten text.

## Guesses at the Riddle of Existence,

And Other Essays on Kindred Subjects. New Edition, with Additions. By GOLDWIN SMITH, D.C.L. **12mo. Cloth. Price, \$1.25.**

The constant demand for this book has brought about a new edition, in which several additions have been made to the text.

"Incisive in thought, fearless and honest in spirit."—*Chicago Tribune*.

## The Gospel for an Age of Doubt

By HENRY VAN DYKE, D.D. (Princeton, Harvard, Yale), LL.D. (Union), Pastor of the Brick Church in New York. *Sixth Edition Revised, with a New Preface.* **12mo. Cloth. Price, \$1.25.**

This, the sixth edition, contains an entirely new preface of considerable length. The book is now issued in a cheaper form and will doubtless attract many new readers.

"It is the best one of a very few books I should venture to put into the hands of a young man troubled by doubts."—JAMES O. MURRAY, D.D., *Dean of Princeton University.*

FOR HOLIDAY BOOKS SEND FOR OUR CHRISTMAS CATALOGUE.

**THE MACMILLAN COMPANY**

New York

Boston

Chicago

San Francisco

# SCIENCE

NEW SERIES.  
VOL. VIII. No. 204.

FRIDAY, NOVEMBER 25, 1898.

SINGLE COPIES, 15 CTS.  
ANNUAL SUBSCRIPTION, \$5.00

## The Bausch & Lomb Optical Co.,

announce the addition to their business of a  
complete stock of

## CHEMICAL APPARATUS AND CHEMICALS.

This New Department is supplied entirely with New Goods selected from the manufactures of the best makers, both American and foreign, hence the purchaser is assured of receiving apparatus of the latest, most improved construction only.

A complete catalogue of this apparatus is in preparation and will soon be issued, meanwhile estimates will be carefully furnished on all lists submitted, AND THE PRICES WILL BE RIGHT.

Please send your address now for catalogue F, which will be mailed when issued.

Address **516½ North St. Paul Street,**

NEW YORK OFFICE:  
25th Street and Broadway,  
Townsend Bldg.

ROCHESTER, N. Y.

CHICAGO OFFICE:  
State and Washington Streets,  
Stewart Bldg.

# Timely Books of General Interest

## The Philippine Islands and Their People

A Record of Personal Observation and Experience, with a Short Summary of the More Important Facts in the History of the Archipelago. By DEAN C. WORCESTER, Assistant Professor of Zoology, University of Michigan. **Svo. Cloth Extra. Price, \$4.00.**

"Full of unexpected information, and still more full of material, interestingly presented, which elaborates the facts regarding the Spanish domination in the Philippines. . . . We strongly recommend this volume, first, because of the great variety and diversity of its information, which is well and discriminatingly presented; and, second, on account of the inherent interest of the whole volume, which is as absorbing, though of course in a different way, as a good adventure story."—*The Herald*, Boston.

## The Control of the Tropics

By BENJAMIN KIDD, Author of "Social Evolution." **12mo. Cloth. Price, 75 cents.**

The appearance of Mr. Kidd's book is particularly timely, and as it deals especially with problems which are now confronting us, its circulation has been very extended; the first edition is about exhausted, and a second is in active preparation.

"Mr. Kidd's thinking is close and logical and his conclusions are well worthy of thoughtful consideration."—*The Tribune*, Chicago.

## The Rise and Growth of American Politics

A Sketch of Constitutional Development. By HENRY JONES FORD. **12mo. Cloth. \$1.50.**

Mr. Ford has set himself a difficult task. From their inception he reviews our politics from the standpoint of an outsider, as Mr. Bryce did in his "American Commonwealth." Yet it is an explanation of causes rather than a narrative of events, aiming to give the reader an understanding of the actual system of government under which we live.

To the student, whether of constitutional history or of political parties, the book is not only readable, but of great value.

## An Outline of Philosophy

With Notes Historical and Critical. By JOHN WATSON, LL.D., Professor of Moral Philosophy in Queen's University, Kingston, Canada; Author of "Kant and his English Critics," etc. *2nd Edition.*

**12mo. Cloth. Price, \$2.25 net.**

The first edition of this work was published under the title of "Comte, Mill, and Spencer: an Outline of Philosophy." The call for a second edition has been answered by the author with a completely revised and partially rewritten text.

## Guesses at the Riddle of Existence,

And Other Essays on Kindred Subjects. New Edition, with Additions. By GOLDWIN SMITH, D.C.L.

**12mo. Cloth. Price, \$1.25.**

The constant demand for this book has brought about a new edition, in which several additions have been made to the text.

"Incisive in thought, fearless and honest in spirit."—*Chicago Tribune*.

## The Gospel for an Age of Doubt

By HENRY VAN DYKE, D.D. (Princeton, Harvard, Yale), LL.D. (Union), Pastor of the Brick Church in New York. *Sixth Edition Revised, with a New Preface.*

**12mo. Cloth. Price, \$1.25.**

This, the sixth edition, contains an entirely new preface of considerable length. The book is now issued in a cheaper form and will doubtless attract many new readers.

"It is the best one of a very few books I should venture to put into the hands of a young man troubled by doubts."—JAMES O. MURRAY, D.D., *Dean of Princeton University.*

FOR HOLIDAY BOOKS SEND FOR OUR CHRISTMAS CATALOGUE.

**THE MACMILLAN COMPANY**

New York

Boston

Chicago

San Francisco



# SCIENCE

NEW SERIES.  
VOL. VIII. No. 205.

FRIDAY, DECEMBER 2, 1898.

SINGLE COPIES, 15 CTS.  
ANNUAL SUBSCRIPTION, \$5.00.

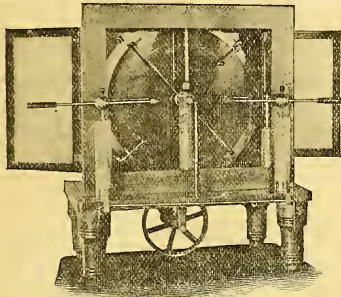

## Static Machines for all purposes. X-Ray Apparatus and Supplies.

SEND FOR BULLETIN No. 24.

### SWETT & LEWIS CO.

9 Bromfield St., Boston, Mass.

**Biologists.** We have recently prepared a number of finely mounted dissections, in glass jars, to illustrate the important anatomical features of the principal types of invertebrate animals. These include the Sea-Anemone, Sea-Cucumber, Sea-Urchin, Starfish, Pond Mussel, Squid, Crayfish, etc., and are superior to anything before obtainable. Prices from \$1.50 to \$4.00 each.

WRITE FOR LIST OF BIOLOGICAL SUPPLIES.

**WARD'S NATURAL SCIENCE ESTABLISHMENT, ROCHESTER, N. Y.**



**MINIATURE INCANDESCENT LAMPS.  
MINIATURE LAMP RECEPTACLES.  
X-RAY TUBES AND APPARATUS.  
FLUOROSCOPES.**

Catalogues on Application.

**Edison Decorative and Miniature Lamp Department,**

(GENERAL ELECTRIC COMPANY,)

**HARRISON, N. J.**

## My New Catalogue B

A college professor writes: "Many thanks for the catalogue of **Electrical Instruments** which I received to-day. Let me congratulate you on the whole 'get-up' of the catalogue. The paper and print are very good, the illustrations excellent and the explanations clear. To my mind it is the best of its kind that I have seen yet."

Send 10 Cents in Stamps for a Copy.

**JAMES G. BIDDLE,**  
909 Drexel Building, Philadelphia.

# A MOST USEFUL AND UNIQUE PRESENT

10 TIMELY BOOKS ON —  
10 DIFFERENT IMPORTANT

# Practical Applications of Electricity

A COMPLETE ELECTRICAL LIBRARY

written for the general reader in plain and simple language,  
devoid of technicalities, and known as the

*“Elementary Electro-Technical Series.”*

~~~~~  
**MAGNETISM.**

294 pages; 94 illustrations.

**ELECTRIC MOTOR.**

377 pages; 122 illustrations.

**ELECTRIC HEATING.**

290 pages; 86 illustrations.

**ELECTRIC TELEPHONE.**

412 pages; 143 illustrations.

**ELECTRIC TELEGRAPHY.**

448 pages; 163 illustrations.  
~~~~~



~~~~~  
**ELECTRIC ARC LIGHTING.**

383 pages; 155 illustrations.

**Electric Street Railways.**

367 pages; 158 illustrations.

**Electricity in Electro-Therapeutics.**

452 pages; 147 illustrations.

**Alternating Electric Currents.**

225 pages; 77 illustrations.

**Electric Incandescent Lighting.**

449 pages; 146 illustrations.  
~~~~~

BY

**Prof. EDWIN J. HOUSTON,**

*Joint inventor of the Thomson-Houston system of electric lighting, author of “Houston’s Dictionary of Electrical Words, Terms and Phrases,” and other works,*

...and...

**Dr. ARTHUR E. KENNELLY,**

*The well-known electrical engineer, for years principal assistant in Mr. Edison’s laboratory, author of “Practical Notes for Electrical Students,” and other works.*

*The 10 books can be had in the box for \$10.00 the set, or separately at \$1.00 each.  
Nothing could be more appropriate for a Christmas or birthday present.*

# The W. J. Johnston Company

Office of THE ELECTRICAL WORLD.

9 Murray Street, New York.

# SCIENCE

NEW SERIES.  
VOL. VIII. No. 206.

FRIDAY, DECEMBER 9, 1898.

SINGLE COPIES, 15 CTS.  
ANNUAL SUBSCRIPTION, \$5.00

## New Laboratory Glassware

From Catalogue BM 1898 sent on request

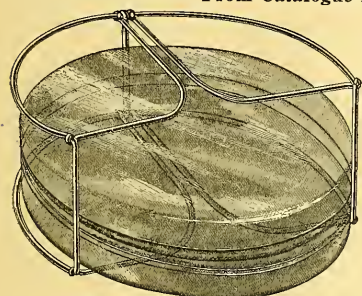

3740a

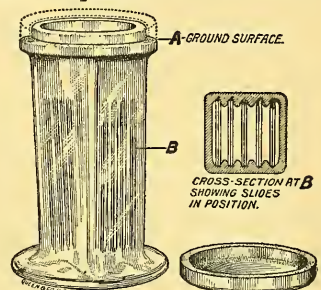

3900



3893

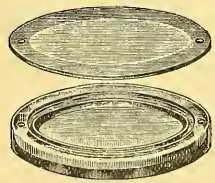

3936



3951

- 3936. **Tetanus Dishes.** A double dish for the growing of tetanus cultures, after Gabritschewsky. 10 cm. diameter. Per pair . . . . . **\$1.00**
- 3900. **Coplin Staining and Preparation Jar,** new and improved form. Devised and used by Prof. W. M. L. Coplin at the Jefferson Medical College. With air-tight cover. Per dozen . . . . . **6.00**  
Without cover for cork stopper . . . . . **4.50**  
*See Micro. Bulletin, August, 1898.*
- 3940a. **Petri Dish Holder.** Suggested by Dr. M. P. Ravenel, of the University of Pennsylvania. A form of wire, nickered, into which may be sprung three or six 4 in. Petri Dishes. Holds them securely. For 3 dishes, each \$0.50; for 6 dishes, each . . . . . **.60**
- 3893. **Balsam Bottle.** New form, with conical collar projecting inside, which readily removes the superfluous balsam from the rod. Capacity, 1½ oz. Price, per dozen, \$3.00. Each . . . . . **.30**

WRITE FOR COLLEGE DISCOUNT

## QUEEN & CO., INC.

Optical and Scientific Instrument Works

59 Fifth Avenue, New York

1010 CHESTNUT ST., PHILADELPHIA



# THE RURAL SCIENCE SERIES

Edited by L. H. BAILEY

*Professor of Horticulture in the Cornell University*

## NEW VOLUMES

By **FRED W. CARD**, *Rhode Island Agricultural College.*

### **BUSH-FRUITS. A Horticultural Monograph of Raspberries, Blackberries, Dewberries, Currants, Gooseberries, and Other Shrub-like Fruits.**

By FRED W. CARD, Professor of Horticulture in Rhode Island Agricultural College.

**537 Pages—113 Illustrations—\$1.50.**

The aim of this book is two-fold—to give all necessary instruction on the cultivation of the bush-fruits, and to provide a cyclopedia of reference to varieties, species, insects, and diseases. Every variety of the various fruits is fully described, this being the first effort to collect all information about varieties of all these fruits since the time of the Downings. In this respect, the book will always be a standard authority. The varieties are arranged alphabetically under various natural classes or groups, but a very full index refers instantly to any variety. The cultural directions are full and clear, and are entirely separated from the descriptions and technical matter. Full instructions are given for the evaporating of berries.

By **EDWARD B. VOORHEES**, *Rutgers College.*

### **FERTILIZERS. The Source, Character, and Composition of Natural, Home-made and Manufactured Fertilizers; and Suggestions as to their Use for Different Crops and Conditions.**

By EDWARD B. VOORHEES, A.M., Director of the New Jersey Agricultural Experiment Stations, and Professor of Agriculture in Rutgers College.

**12mo. Cloth. \$1.00**

It has been the aim of the author to point out the underlying principles and to discuss some of the important problems connected with the use of fertilizer materials. Much is being done in the experiment stations, and every practical man should have a clear understanding of what is now known, in order to be prepared to use the knowledge undoubtedly to be provided soon.

## Prof. Bailey's Latest Book

### **THE EVOLUTION OF OUR NATIVE FRUITS.**

By L. H. BAILEY, Cornell University.

**485 Pages—125 Illustrations—\$2.00.**

In this entertaining volume, the origin and development of the fruits peculiar to North America are inquired into, and the personality of those horticultural pioneers whose almost forgotten labors have given us our most valuable fruits is touched upon. There has been careful research into the history of the various fruits, including inspection of the records of the great European botanists who have given attention to American economic botany. The conclusions reached, the information presented, and the suggestions as to future developments, cannot but be valuable to any thoughtful fruit-grower, while the terse style of the author is at its best in his treatment of the subject.

*Send for a new Circular of the Garden Craft and Rural Science Series.*

**THE MACMILLAN COMPANY, Publishers, New York**

162740

# SCIENCE

NEW SERIES.  
VOL. VIII. No. 207.

FRIDAY, DECEMBER 16, 1898.

SINGLE COPIES, 15 CTS.  
ANNUAL SUBSCRIPTION, \$5.00

## Chemical and Physical Apparatus

### CHEMICAL PURE ACIDS AND

### CHEMICALS

SELLING AGENTS FOR

Spencer  
Lens  
Company  
and  
Carl  
Zeiss,  
Jena

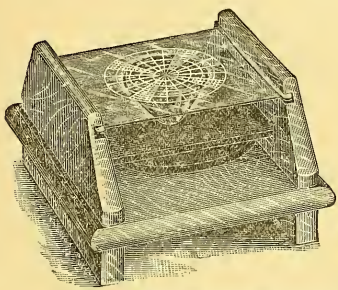

Mason-Miller-McPherson Bacteria Counter



Baker &  
Adamson  
Chemical Co.  
and  
Desmontis,  
Lemaire & Co.'s  
Platinum

SOLE AGENTS FOR

SCHOTT & GONOSSEN, JENA NORMAL GLASS  
SCHLEICHER & SCHÜLL'S CHEM. PURE FILTERS  
SCHMIDT & HAENSCH'S OPTICAL APPARATUS  
MAX KOHL'S PHYSICAL APPARATUS

Trade Mark



## EIMER & AMEND

Trade Mark



205, 207, 209, 211 Third Ave.

NEW YORK

# Timely Books of General Interest

## The Philippine Islands and Their People

A Record of Personal Observation and Experience, with a Short Summary of the More Important Facts in the History of the Archipelago. By DEAN C. WORCESTER, Assistant Professor of Zoology, University of Michigan. **Svo. Cloth Extra. Price, \$1.00.**

"Full of unexpected information, and still more full of material, interestingly presented, which elaborates the facts regarding the Spanish domination in the Philippines. . . . We strongly recommend this volume, first, because of the great variety and diversity of its information, which is well and discriminately presented; and, second, on account of the inherent interest of the whole volume, which is as absorbing, though of course in a different way, as a good adventure story."—*The Herald*, Boston.

## The Control of the Tropics

By BENJAMIN KIDD, Author of "Social Evolution." **12mo. Cloth. Price, 75 cents.**

The appearance of Mr. Kidd's book is particularly timely, and as it deals especially with problems which are now confronting us, its circulation has been very extended; the first edition is about exhausted, and a second is in active preparation.

"Mr. Kidd's thinking is close and logical and his conclusions are well worthy of thoughtful consideration."—*The Tribune*, Chicago.

## The Rise and Growth of American Politics

A Sketch of Constitutional Development. By HENRY JONES FORD. **12mo. Cloth. \$1.50.**

Mr. Ford has set himself a difficult task. From their inception he reviews our politics from the standpoint of an outsider, as Mr. Bryce did in his "American Commonwealth." Yet it is an explanation of causes rather than a narrative of events, aiming to give the reader an understanding of the actual system of government under which we live.

To the student, whether of constitutional history or of political parties, the book is not only readable, but of great value.

## An Outline of Philosophy

With Notes Historical and Critical. By JOHN WATSON, LL.D., Professor of Moral Philosophy in Queen's University, Kingston, Canada; Author of "Kant and his English Critics," etc. *2nd Edition.*

**12mo. Cloth. Price, \$2.25 net.**

The first edition of this work was published under the title of "Comte, Mill, and Spencer: an Outline of Philosophy." The call for a second edition has been answered by the author with a completely revised and partially rewritten text.

## Guesses at the Riddle of Existence,

And Other Essays on Kindred Subjects. New Edition, with Additions. By GOLDWIN SMITH, D.C.L.

**12mo. Cloth. Price, \$1.25.**

The constant demand for this book has brought about a new edition, in which several additions have been made to the text.

"Incisive in thought, fearless and honest in spirit."—*Chicago Tribune*.

## The Gospel for an Age of Doubt

By HENRY VAN DYKE, D.D. (Princeton, Harvard, Yale), LL.D. (Union), Pastor of the Brick Church in New York. *Sixth Edition Revised, with a New Preface.* **12mo. Cloth. Price, \$1.25.**

This, the sixth edition, contains an entirely new preface of considerable length. The book is now issued in a cheaper form and will doubtless attract many new readers.

"It is the best one of a very few books I should venture to put into the hands of a young man troubled by doubts."—JAMES O. MURRAY, D.D., *Dean of Princeton University.*

FOR HOLIDAY BOOKS SEND FOR OUR CHRISTMAS CATALOGUE.

**THE MACMILLAN COMPANY**

New York

Boston

Chicago

San Francisco



# SCIENCE

NEW SERIES.  
VOL. VIII. No. 208.

FRIDAY, DECEMBER 23, 1898.

SINGLE COPIES, 15 CTS.  
ANNUAL SUBSCRIPTION, \$5.00.

## DISSECTING MICROSCOPES

of every size, style and price, suited for all kinds of work.

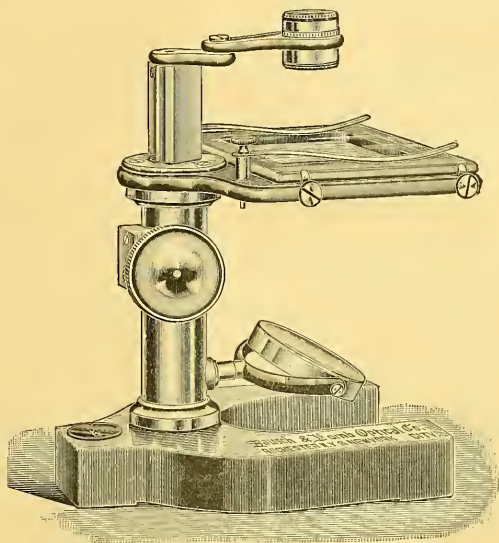

NEW W DISSECTING MICROSCOPE.

**A** NEW series of lenses for dissecting work, which have unusually long working distance and large flat field, has recently been perfected by us. These lenses are offered at prices less than any lenses of equal quality heretofore in use. The new Dissecting Stands are all nickeled metal, have glass stages. Catalog free.

### BAUSCH & LOMB OPTICAL CO.

NEW YORK OFFICE:  
25th Street and Broadway,  
Townsend Bldg.

ROCHESTER, N. Y.

CHICAGO OFFICE:  
State and Washington Streets,  
Stewart Bldg.

# THE MACMILLAN COMPANY'S

MOST RECENT SCIENTIFIC PUBLICATIONS

## INDUSTRIAL SCIENCE

### Cotton Spinning

By WILLIAM SCOTT TAGGART. Vol. III. With Illustrations. 12mo. Cloth. pp. xxi+136. \$1.00.

Vol. I. Including All Processes up to End of Carding. Introduction—The Cotton Fibre—Cotton Gins—Bale Breakers—Cotton Mixing—Openers—Openers and Scutchers—Carding.

Vol. II. Including the Processes up to the End of Fly Frames. Drawing—Combing—Fly Frames.

Vol. III. Spinning and the Preparation of Yarns. Theory of Spinning—Mechanism and Working of the Mule—The Ring Spinning Frame—Bobbin Winding Frame—Doubling—Yarn Preparing Machines—Mill Planning—Humidity—Useful Information—Appendix—Index.

Price, per Set, \$7.50.

## CHEMISTRY

### Outlines of Industrial Chemistry

A TEXT-BOOK FOR STUDENTS. By FRANK HALL THORP, Ph.D., Instructor in Industrial Chemistry in the Massachusetts Institute of Technology. 8vo. Cloth. pp. xx+511. Price, 3.50 net.

## BOTANY

### The Evolution of Our Native Fruits

By L. H. BAILEY, Cornell University.

185 Pages. 125 Illustrations. Price, \$2.00.

### An Elementary Text-Book of Botany

By SIDNEY H. VINES, D.Sc., F.R.S.; University of Oxford. With 397 illustrations.

8vo. Cloth. pp. xv+611. Price, \$2.25 net.

## THE RURAL SCIENCE SERIES.

*Illustrated New Volumes.* Edited by Professor L. H. BAILEY, Cornell University.

### Bush Fruits

A HORTICULTURAL MONOGRAPH OF RASPBERRIES, BLACKBERRIES, DEWBERRIES, CURRANTS, GOOSEBERRIES, AND OTHER SHRUB-LIKE FRUITS. By FRED. W. CARD, Professor of Horticulture in Rhode Island Agricultural College. 337 Pages. Price, \$1.50.

### Fertilizers

THE SOURCE, CHARACTER, AND COMPOSITION OF NATURAL, HOME-MADE AND MANUFACTURED FERTILIZERS; AND SUGGESTIONS AS TO THEIR USE FOR DIFFERENT CROPS AND CONDITIONS. By EDWARD B. VOORHEES, A.M., Director of the New Jersey Agricultural Experiment Stations, and Professor of Agriculture in Rutgers College. 12mo. Cloth. Price, \$1.00.

## MATHEMATICS

### Descriptive Geometry—Pure and Applied

WITH A CHAPTER ON HIGHER PLANE CURVES AND THE HELIX. A Theoretical and Practical Treatise including Problems of Intersection, Development, Tangency, etc., Working Drawings by both the First and Third Angle Systems, Trihedrals, Map Projection, Shadows and Perspective, Axonometric (including Isometric) Projection, Oblique Projection, Kinematic Geometry, Projective Geometry and Relief Perspective, the Conic Sections, Trochoids, Spirals, etc., Prepared for Courses in General Science, Engineering, and Architecture. By FREDERICK NEWTON WILLSON, C.E.

4to. Cloth. pp. 250+16 unnumbered. Price, \$3.00 net.

## PHYSICS

### Matter, Energy, Force, and Work

A PLAIN PRESENTATION OF FUNDAMENTAL PHYSICAL CONCEPTS AND OF THE VORTEX-ATOM AND OTHER THEORIES. By SILAS W. HOLMAN, Professor of Physics (Emeritus), Massachusetts Institute of Technology. 12mo. Cloth. pp. xiv+257. Price, \$2.50 net.

*Send for a new Circular of the Garden Craft and Rural Science Series.*

THE MACMILLAN COMPANY, Publishers, New York

# SCIENCE

NEW SERIES.  
VOL. VIII. No. 209.

FRIDAY, DECEMBER 30, 1898.

SINGLE COPIES, 15 CTS.  
ANNUAL SUBSCRIPTION, \$5.00

*JUST READY.*

## A TEXT=BOOK

By  
**Carl Schnabel**

OF

Translated by  
**Henry Louis**

## METALLURGY

**Two Volumes. Illustrated. Medium 8vo. \$10 net.**

A Translation of Dr. Carl Schnabel's Hand-Book of Metallurgy. Edited by HENRY LOUIS, Professor of Mining in the Durham College of Science.

The German original is acknowledged to be the best existing work on the subject; and there is only one other in English at present which can be compared with it. This new translation has the advantages of being well up to date and absolutely modern in its descriptions of methods of treatment, etc.

Up-to-date.  
Modern in Method.  
Applicable to  
American conditions.  
The best work on  
the subject.  
Fully Illustrated.

The author's high reputation vouches for the value and interest of the book which will appeal the more to American students for the fact of its giving considerable attention to work which has been done in different parts of the United States.

The standing held by Dr. Schnabel among metallurgists is indicated by his having recently been sent for from Australia to advise in regard to some complex silver ores discovered there.

The translator's name has long been connected with mining and kindred subjects, not only through his book on "Gold Milling," published a few years since, and described by the "Mining Review" as "one of the most concise, practical and complete treatises yet published," but also because of his practical knowledge of all the details (the chemistry, etc.) of the subject, and of the investigations which have been made in all parts of the world.

PUBLISHED BY

**THE MACMILLAN COMPANY, New York**



# Important Scientific Books Published

On Botany, Biology, Chemistry, Mathematics,

- BAILEY.**—Lessons with Plants. Suggestions for Seeing and Interpreting some of the Common Forms of Vegetation. By L. H. BAILEY, Professor of Horticulture in Cornell University. 401 pp., 446 illustrations, half leather, 12mo, \$1.10.
- The Evolution of Our Native Fruits. By L. H. BAILEY, Professor of Horticulture in Cornell University. 485 pp., 125 illus., \$2.00.
- THE GARDEN CRAFT SERIES.*
- Garden Making. Suggestions for the Utilizing of Home Grounds. By L. H. BAILEY, aided by L. R. TAFT, F. A. WAUGH and ERNEST WALKER. 417 pp., 256 illus., \$1.00.
- The Pruning Book. A Monograph of the Pruning and Training of Plants as Applied to American Conditions. By L. H. BAILEY, Professor of Horticulture in Cornell University. 540 pp., 332 illustrations, \$1.50.
- THE RURAL SCIENCE SERIES.*
- Bush Fruits. A Horticultural Monograph of Raspberries, Blackberries, Dewberries, Currants, Gooseberries and other Shrub-like Fruits. By FRED W. CARD, Professor of Horticulture in Rhode Island Agricultural College. 537 pp., 113 illustrations, \$1.50.
- Fertilizers. The Source, Character and Composition of Natural, Home-made and Manufactured Fertilizers; and Suggestions as to Their Use for Different Crops and Conditions. By EDWARD B. VOORHEES, Director of the New Jersey Experiment Station and Professor of Agriculture in Rutgers College. 335 pp., \$1.00.
- STRASBURGER.**—A Text-Book of Botany. By EDWARD STRASBURGER, FRITZ NOLL, HEINRICH SCHENCK and A. F. W. SCHIMPER. Translated by H. C. PORTER, University of Pennsylvania. With 594 illustrations, in part colored. Cloth, 8vo. \$4.50 net. Also in 2 vols.
- Part I. General Botany. \$2.50.  
Part II. Special Botany. \$2.50.
- VINES.**—An Elementary Text-Book of Botany. By SIDNEY H. VINES, M.A., D.Sc., F.R.S., Professor of Botany in the University of Oxford. With 397 illustrations. 8vo, cloth, pp. 611. \$2.25 net.
- MILLS.**—The Nature and Development of Animal Intelligence. By WESLEY MILLS, M.D., Professor of Physiology in McGill University, Montreal, Author of "Comparative Physiology," etc. 8vo, cloth, pp. 307. \$2.00.
- PACKARD.**—A Text-Book of Entomology. Including the Anatomy, Physiology, Embryology and Metamorphoses of Insects. For use in Agricultural and Technical Schools and Colleges, as well as by the Working Entomologist. By ALPHEUS S. PACKARD, Brown University. Author of "Entomology for Beginners," etc. With over 400 illustrations. Cloth, 8vo. \$4.00 net.
- PARKER and HASWELL.**—A Text-Book of Zoology. By T. JEFFERY PARKER, D.Sc., F.R.S., and WILLIAM A. HASWELL, M.A., D.Sc., F.R.S. In two volumes containing many illustrations. 2 vols, 8vo, cloth. \$9.00 net.
- A Student's Text-Book of Zoology. By ADAM SEDGWICK, Trinity College, Cambridge. With over 400 illustrations. Vol. I. Protozoa—Chatognatha. 8vo, cloth, pp. 619. \$4.50 net.
- WOODWARD.**—Outlines of Vertebrate Paleontology. For Students of Zoology. By ARTHUR SMITH WOODWARD. *Cambridge Natural Science Manuals, Biological Series.* Large 8vo, cloth, pp. 470. \$3.50 net.
- LANGE.**—Handbook of Nature Study for Teachers and Pupils in Elementary Schools. By D. LANGE, Instructor in Nature Study in the Public Schools of St. Paul, Minnesota. With many illustrations, an Appendix and Index. 12mo, cloth, pp. 329. \$1.00 net.
- WILSON.**—Nature Study in Elementary Schools. By Mrs. LUCY LANGDON WILLIAMS WILSON, Ph.D., Head of the Biological Laboratories in the Philadelphia Normal School for Girls, etc. I. Myths, Stories and Poems. 35 cents net.  
II. Manual for Teachers. 90 cents net.
- BENEDIKT and LEWKOWITSCH.**—Chemical Analysis of Oils, Fats, Waxes and the Commercial Products Derived Therefrom, founded on Benedikt's second edition of "Analyse der Fette," by Dr. J. LEWKOWITSCH. 2d edition, 8vo, \$8.00.
- JONES.**—An Introduction to the Science and Practice of Qualitative Chemical Analysis. Inorganic. By CHAPMAN JONES. 12mo, cloth, pp. 213, \$1.50 net.
- THORP.**—Outlines of Industrial Chemistry. A Text-book for Students. By FRANK HALL THORP, Ph.D., Instructor in Industrial Chemistry, Mass. Inst. of Technology. 8vo, cloth, pp. 541, \$3.50 net.
- CRYSTAL.**—Introduction to Algebra for the Use of Secondary Schools and Technical Colleges. By G. CRYSTAL, Professor of Mathematics, University of Edinburgh. 12mo, cloth, \$1.25 net.
- NICHOLSON.**—Elements of Plane and Spherical Trigonometry. By J. W. NICHOLSON, A.M., LL.D., Professor of Mathematics, Louisiana State University and Agricultural and Mechanical College. 8vo, cloth, pp. 107, 90 cents net. The same with Logarithmic and Trigonometric Tables. Pp. 101+61, \$1.10 net.
- MCCLELLAN and AMES.** The Primary Public School Arithmetic, based on McClellan and Davey's "Psychology of Number," by J. A. MCCLELLAN, M.A., LL.D., President of the Ontario Normal College, etc., and A. F. AMES, A.B., Superintendent of Schools, Riverside, Ill., etc. Small 12mo, cloth, pp. 253. 35 cents net. Teachers' Edition Containing Answers. Pp. lxxxiii+265, 50 cents net.
- REYE.**—The Geometry of Position, by Dr. THEODORE REYE, Professor in the University of Strassburg, translated by THOMAS F. HOLTGATE, Professor of Applied Mathematics in Northwestern University. Part I. \$2.25. Part II. *In preparation.*
- SMITH.**—Infinitesimal Analysis. By WILLIAM BENJAMIN SMITH, Tulane University. Vol. I. Elementary: Real Variables. 8vo, cloth. \$3.25 net.
- WHITEHEAD.**—A Treatise on Universal Algebra, With Applications, by ALFRED NORTH WHITEHEAD, Fellow and Lecturer of Trinity College, Cambridge. Vol. I. Imp. 8vo, \$7.00.
- WILLSON.**—Theoretical and Practical Graphics. An Educational Course in the Theory and Practical Applications of Descriptive Geometry and Mechanical Drawing, Prepared for Students in General Science, Engineering or Architecture. By FREDERICK NEWTON WILLSON, C.E. (Rensselaer), A.M. (Princeton). 4to, cloth. \$4.00 net.

Published by **THE MACMILLAN COMPANY,**



















SMITHSONIAN INSTITUTION LIBRARIES



3 9088 01301 4220